



US 20150279578A1

(19) **United States**

(12) **Patent Application Publication**
Martini et al.

(10) **Pub. No.: US 2015/0279578 A1**

(43) **Pub. Date: Oct. 1, 2015**

(54) **HIGH POWER AND HIGH ENERGY ELECTRODES USING CARBON NANOTUBES**

(60) Provisional application No. 61/524,071, filed on Aug. 16, 2011.

(71) Applicants: **Fabrizio Martini**, Boston, MA (US);
Nicolo Michele Brambilla, Brookline, MA (US); **Riccardo Signorelli**, Cambridge, MA (US)

Publication Classification

(51) **Int. Cl.**
H01G 11/86 (2006.01)
H01G 11/28 (2006.01)
H01G 11/36 (2006.01)
H01G 11/68 (2006.01)

(72) Inventors: **Fabrizio Martini**, Boston, MA (US);
Nicolo Michele Brambilla, Brookline, MA (US); **Riccardo Signorelli**, Cambridge, MA (US)

(52) **U.S. Cl.**
CPC **H01G 11/86** (2013.01); **H01G 11/68** (2013.01); **H01G 11/28** (2013.01); **H01G 11/36** (2013.01)

(73) Assignee: **FASTCAP SYSTEMS CORPORATION**, Boston, MA (US)

(21) Appl. No.: **14/679,393**

(57) **ABSTRACT**

(22) Filed: **Apr. 6, 2015**

An electrode useful in an energy storage system, such as a capacitor, includes an electrode that includes at least one to a plurality of layers of compressed carbon nanotube aggregate. Methods of fabrication are provided. The resulting electrode exhibits superior electrical performance in terms of gravimetric and volumetric power density.

Related U.S. Application Data

(63) Continuation of application No. 13/587,037, filed on Aug. 16, 2012, now Pat. No. 9,001,495.

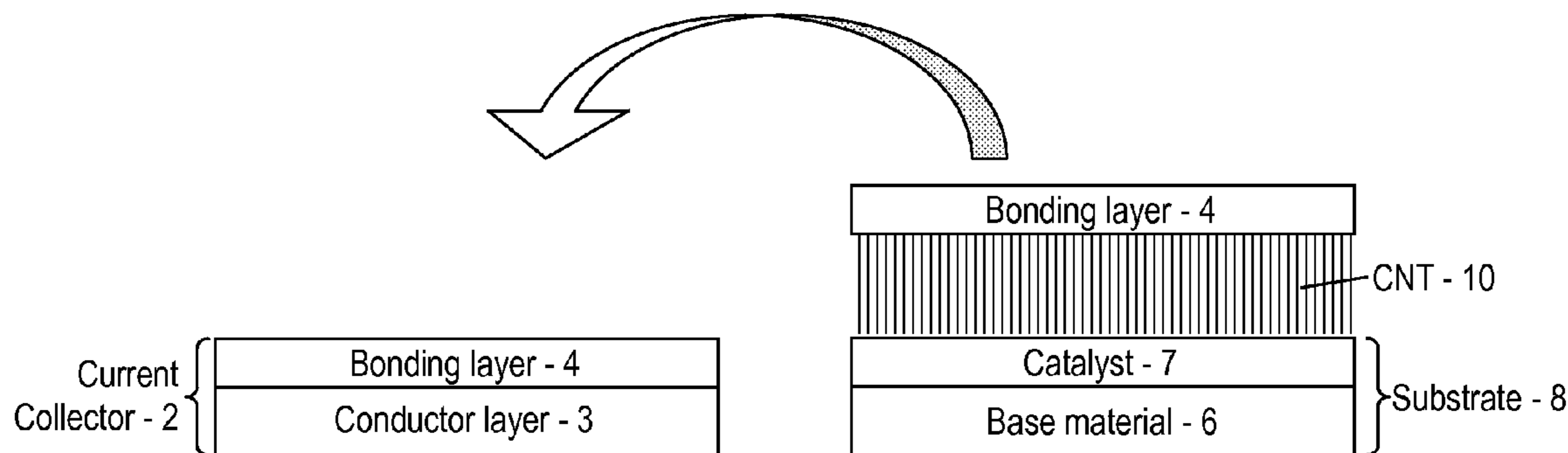

Fig. 1

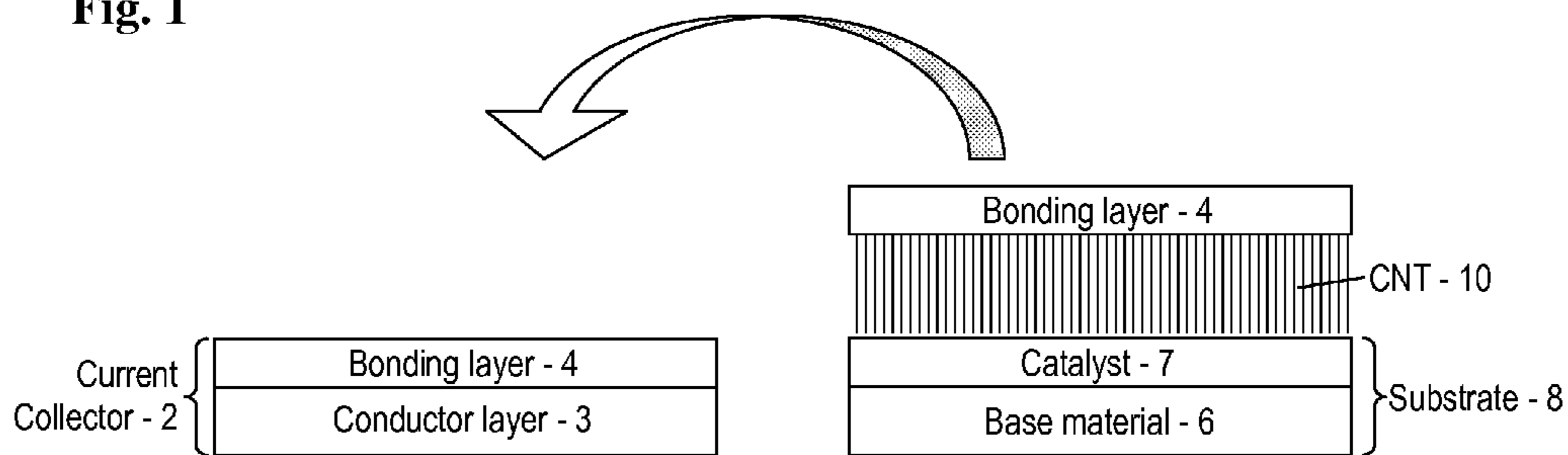

Fig. 2

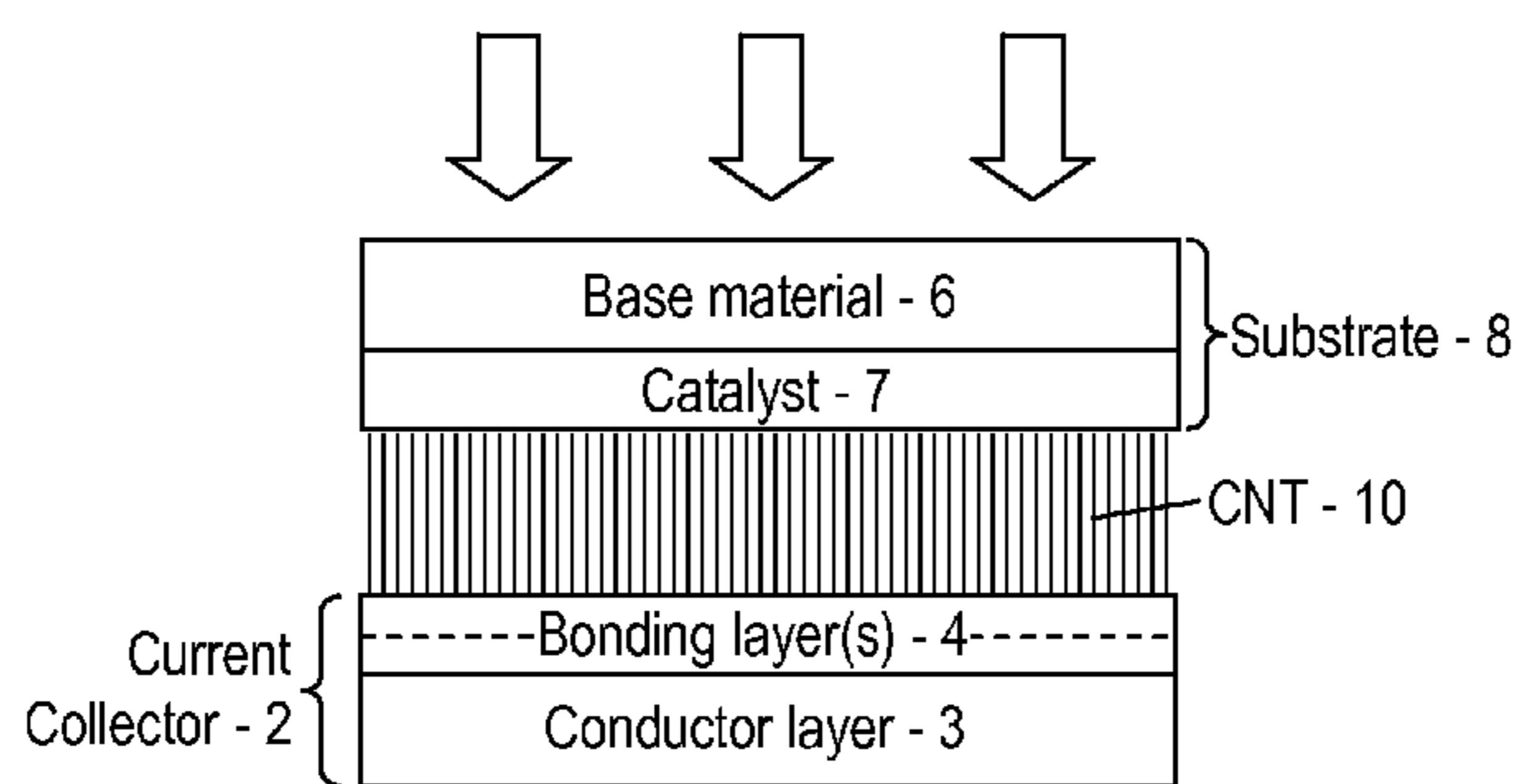

Fig. 3

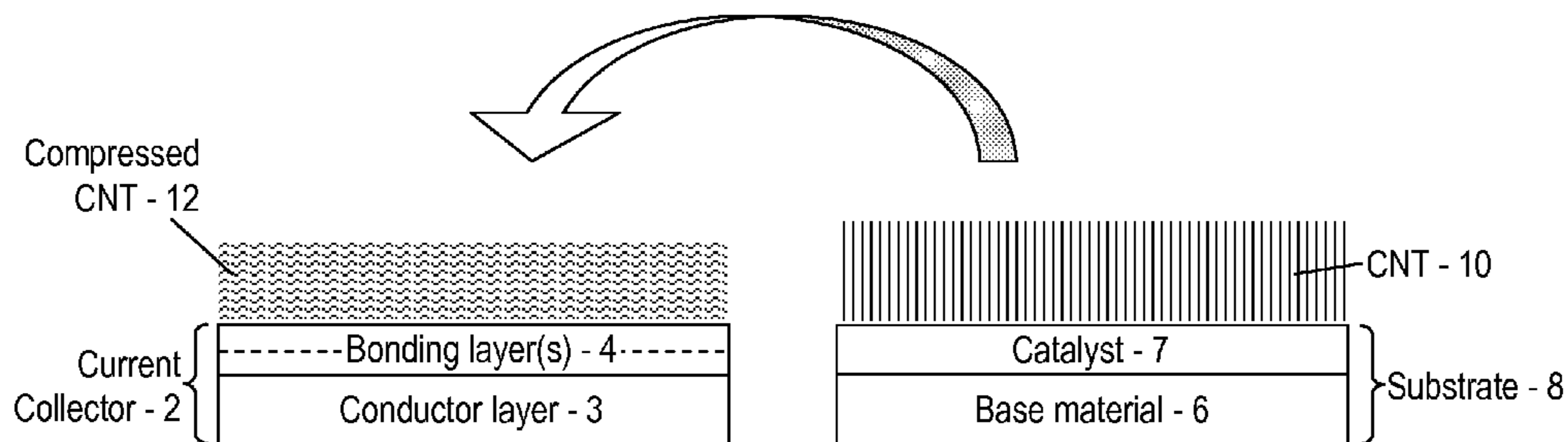

Fig. 4

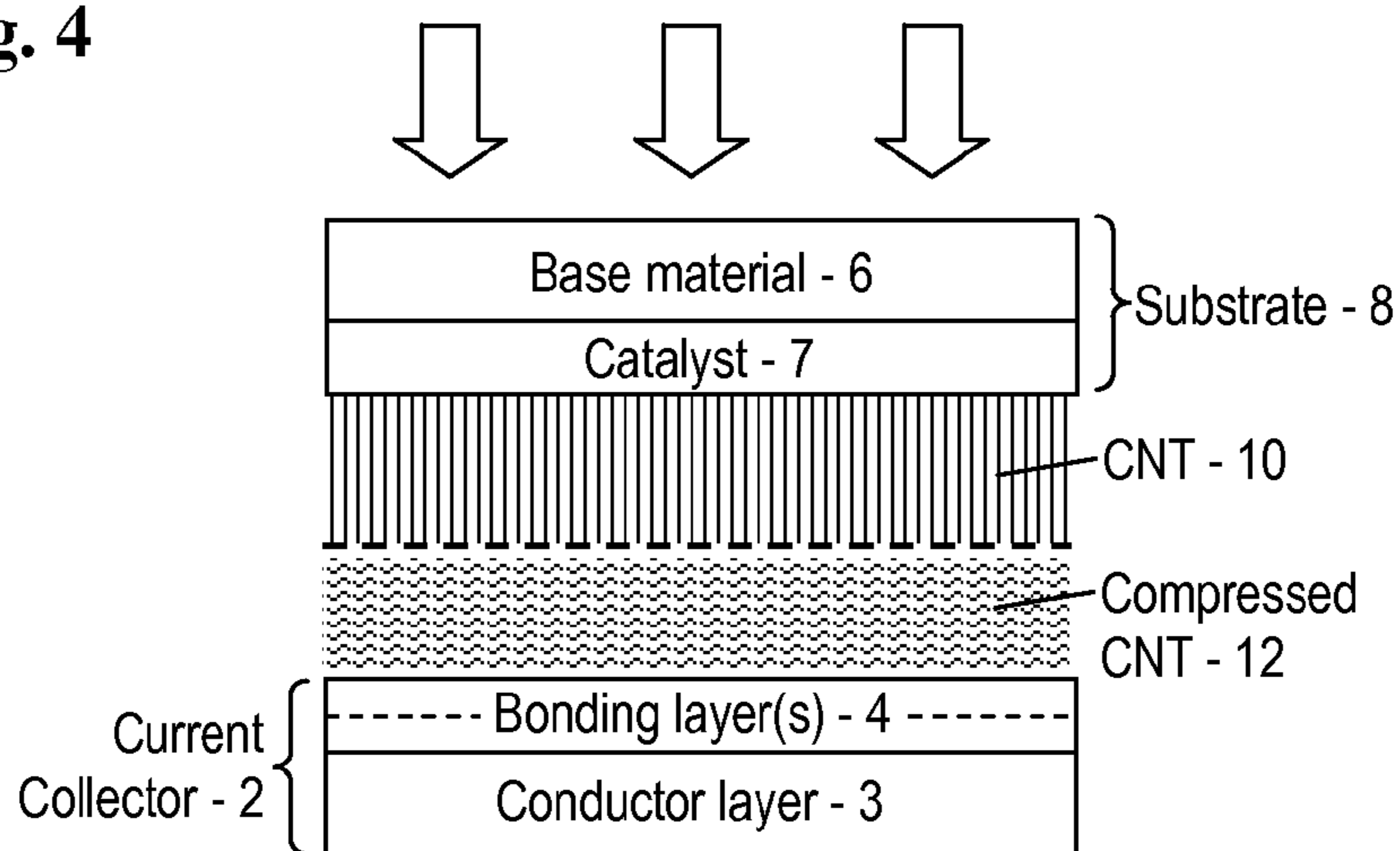
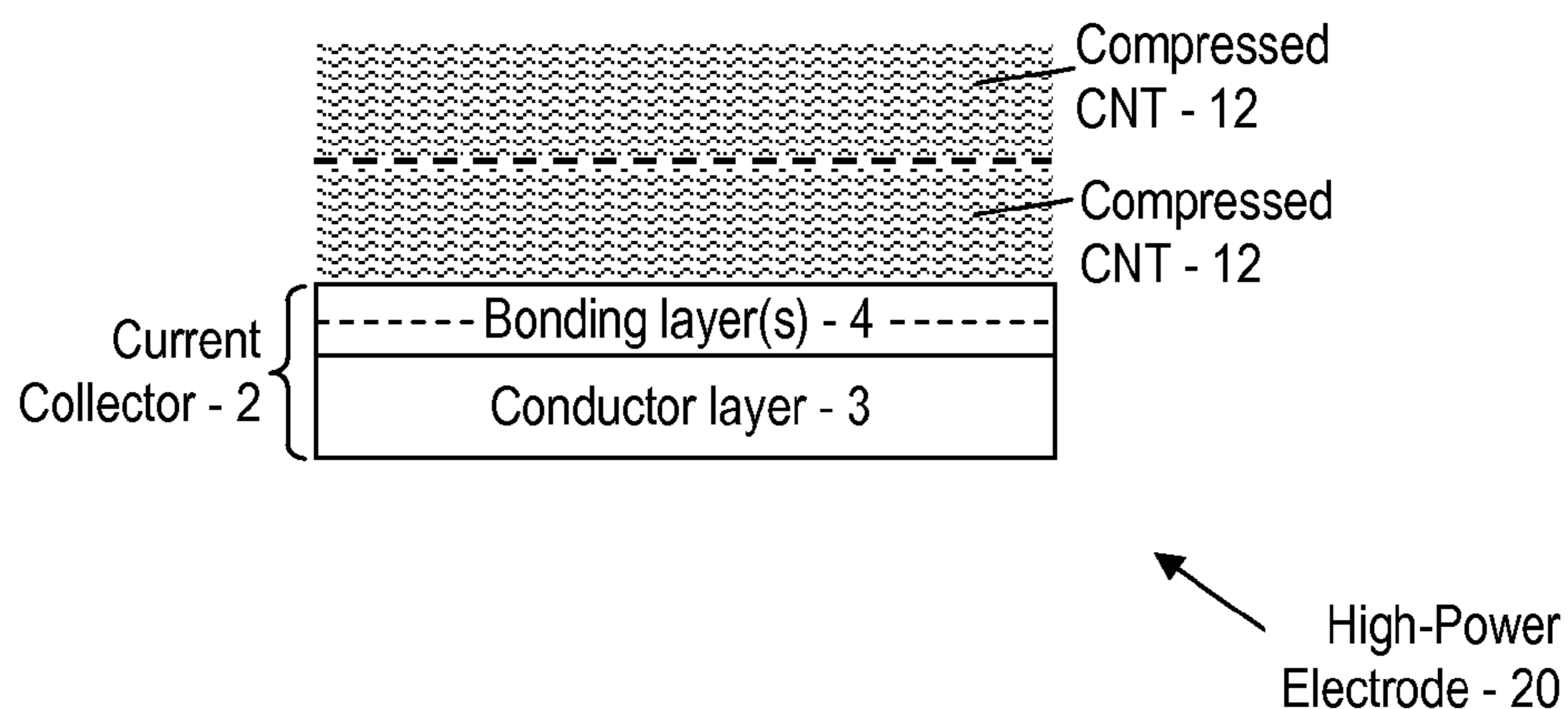

Fig. 5



HIGH POWER AND HIGH ENERGY ELECTRODES USING CARBON NANOTUBES

STATEMENT OF FEDERALLY SPONSORED RESEARCH

[0001] This invention was made with government support under grant DE-AR0000035/0001 awarded by the United States Department of Energy (ARPA-E). The United States government has certain rights in the invention.

BACKGROUND OF THE INVENTION

[0002] 1. Field of the Invention

[0003] The present invention relates to producing aligned carbon-nanotube aggregates and, in particular, to methods and apparatus for producing carbon-nanotube aggregates.

[0004] 2. Description of the Related Art

[0005] Carbon nanotubes (hereinafter referred to also as “CNTs”) are carbon structures that exhibit a variety of properties. Many of the properties suggest opportunities for improvements in a variety of technology areas. These technology areas include electronic device materials, optical materials as well as conducting and other materials. For example, CNTs are proving to be useful for energy storage in capacitors.

[0006] However, effective transfer of the CNTs onto a current collector for a capacitor has proven to be challenging. Further, techniques have not enabled transfer of CNTs in a form that will provide for desired power capabilities.

[0007] Thus, what are needed are methods and apparatus for production of a high power electrode based on carbon nanotubes. Preferably, the methods and apparatus are simple to perform and thus offer reduced cost of manufacture, as well as an improved rate of production.

BRIEF SUMMARY OF THE INVENTION

[0008] In one embodiment, an electrode is provided. The electrode includes a current collector that has at least one layer of compressed carbon nanotubes disposed thereon.

[0009] In another embodiment, a method for fabricating an electrode is provided. The method includes selecting a current collector that has a bonding layer disposed thereon; and bonding to the bonding layer another bonding layer including a layer of aligned carbon nanotubes disposed thereon.

[0010] In yet another embodiment, a method for fabricating an aligned carbon nanotube aggregate for an electrode is provided. The method includes selecting a substrate; growing the aligned carbon nanotube aggregate onto the substrate; and disposing a bonding layer onto the aligned carbon nanotube aggregate following the growth thereof, wherein the bonding layer is adapted for bonding with a current collector of the electrode.

[0011] In a further embodiment, an ultracapacitor is provided. The ultracapacitor includes at least one electrode comprising a current collector that has at least one layer of compressed carbon nanotubes disposed thereon.

[0012] In yet another embodiment, a method for fabricating an ultracapacitor is provided. The method includes selecting an electrode having at least one layer of compressed carbon nanotubes disposed thereon and including the electrode in the ultracapacitor.

BRIEF DESCRIPTION OF DRAWINGS

[0013] The foregoing and other features and advantages of the invention are apparent from the following detailed description taken in conjunction with the accompanying drawings in which:

[0014] FIG. 1 is a block diagram depicting a current collector and a substrate onto which a plurality of carbon nanotubes (CNT) have been formed;

[0015] FIG. 2 is a block diagram depicting loading the CNT of FIG. 1 onto the current collector;

[0016] FIG. 3 is a block diagram depicting the loaded current collector of FIG. 2, as well as another substrate prepared for transfer of additional CNT onto the loaded current collector;

[0017] FIG. 4 is a block diagram depicting loading of additional CNT onto the loaded current collector; and

[0018] FIG. 5 is a block diagram depicting a high-power electrode resulting from multiple transfers of CNT onto the current collector of FIG. 1.

DETAILED DESCRIPTION OF THE INVENTION

[0019] Disclosed are methods and apparatus for providing a high-power electrode, where the electrode includes at least one layer of carbon nanotube aggregate (CNT). Advantageously, the electrode may be fabricated from mass-produced CNT and exhibits, among other things, higher gravimetric power density (power as a function of weight) and volumetric power density (power as a function of volume) than previously achievable. Further, the high-power electrode exhibits a low internal resistance and can be fabricated to provide high voltages (of about four or more volts).

[0020] In order to provide some context for the teachings herein, reference is first made to U.S. Pat. No. 7,897,209, entitled “Apparatus and Method for Producing Aligned Carbon Nanotube Aggregate.” This patent is incorporated herein by reference, in its entirety.

[0021] The foregoing patent (the “’209 patent”) teaches a process for producing aligned carbon nanotube aggregate.” Accordingly, the teachings of the ’209 patent, which are but one example of techniques for producing aligned carbon nanotube aggregate, may be used to produce carbon nanotube aggregate (CNT) referred to herein.

[0022] One example of a device incorporating an electrode as provided herein is provided in U.S. Patent Application Publication No. 2007-0258192, entitled “Engineered Structure for Charge Storage and Method of Making,” also incorporated herein by reference, in its entirety. In general, methods and apparatus disclosed herein may be used to enhance an energy storage system, such as the embodiments disclosed in this publication. One embodiment of such energy storage is referred to as an “ultracapacitor.” However, it should be recognized that the teachings herein may be applicable to other embodiments of energy storage and are therefore not limited to practice with an ultracapacitor.

[0023] Referring now to FIG. 1, there is shown a first component, a current collector 2. Generally, the current collector 2 includes a conductor layer 3, and may include a bonding layer 4. The conductor layer 3 may be fabricated from any material suited for conducting charge in the intended application. An exemplary material includes aluminum. The conductor layer 3 may be presented as a foil, a mesh, a plurality of wires or in other forms. Generally, the

conductor layer 3 is selected for properties such as conductivity and being electrochemically inert.

[0024] In some embodiments, the conductor layer 3 is prepared by removing an oxide layer thereon. The oxide may be removed by, for example, etching the conductor layer 3 with KOH.

[0025] In some embodiments, a bonding layer 4 is disposed on the conducting layer 3. The bonding layer 4 may appear as a thin layer, such as layer that is applied by sputtering, e-beam or through another suitable technique. In various embodiments, the bonding layer 4 is between about 1 nm to about 100 nm. Generally, the bonding layer 4 is selected for its properties such as conductivity, being electrochemically inert and compatibility with the material of the conductor layer 3. Some exemplary materials include aluminum, gold, silver, palladium, titanium, tin and platinum as well as alloys or in combinations of materials, such as Fe—Cr—Ni.

[0026] A second component includes a substrate 8 that is host to the carbon nanotube aggregate (CNT) 10. Some exemplary techniques for providing the CNT 10 are provided in the '209 patent. In the embodiment shown in FIG. 1, the substrate 8 includes a base material 6 with a thin layer of a catalyst 7 disposed thereon.

[0027] In general, the substrate 8 is at least somewhat flexible (i.e., the substrate 8 is not brittle), and is fabricated from components that can withstand environments for deposition of the CNT 10 (e.g., a high-temperature environment of between about 400 degrees Celsius to about 1,100 degrees Celsius).

[0028] Once the CNT 10 have been fabricated, another bonding layer 4 is disposed thereon. In some embodiments, the another bonding layer 4 is between about 10 nm to 1,000 nm thick. Subsequently, the bonding layer 4 of the current collector 2 is mated with the another bonding layer 4 disposed over the CNT 10, as shown in FIG. 2.

[0029] FIG. 2 illustrates aspects of mating the CNT 10 with the current collector 2. As implied by the downward arrows, pressure is applied onto the base material 6. The application of the CNT 10 may be accompanied by heating of the components. As an example, when platinum is used in the bonding layers 4, heating to between about 200 degrees Celsius to about 250 degrees Celsius is generally adequate. Subsequently, the CNT 10 and the catalyst 7 are separated, with a resulting layer of CNT 10 disposed onto the current collector 2.

[0030] Various post-manufacture processes may be completed to encourage separation of the CNT 10 from the catalyst 7. For example, following completion of deposition, the substrate 8 including the CNT 10 thereon may be exposed to (e.g., heated in) an environment of room air, carbon dioxide or another oxidative environment. Generally, the post-manufacture treatment of the CNT 10 includes slowly ramping the CNT 10 to an elevated temperature, and then maintaining the CNT 10 at temperature for a few hours at a reduced pressure (i.e., below 1 atmosphere).

[0031] As shown in FIG. 3, the process of transferring the CNT 10 onto the current collector 2 with the addition of pressure results in a layer of compressed CNT 12. The compressed CNT 12, which now include physical defects, such as windows and cracks, generally provide more surface area for charge storage, while in a smaller volume than the uncompressed CNT 10. Also shown in FIG. 3, is the addition of another layer of CNT 10.

[0032] As shown in FIG. 4, the another layer of CNT 10 may be applied over the compressed CNT 12. In some embodiments, this process involves applying a nominal amount of pressure (such as by hand). Generally, it is considered that the another layer of CNT 10 is transferred to (i.e., adheres to) the compressed CNT 12 by the Van der Waals forces between the carbon nanotubes. Advantageously, this results in another layer of compressed CNT 12 (i.e., another thickness of compressed CNT 12) on the current collector 2.

[0033] The process may be repeated to provide a plurality of thicknesses of compressed CNT 12 on the current collector 2. In general, however, it is expected that certain practical limitations will be realized. That is, for example, compounding defects in transfer of each layer may result in a layer of compressed CNT 12 that does not exhibit desired performance for charge storage. However, it is also expected that as transfer protocols continue to improve, that the addition of an ever greater number of layers will be possible.

[0034] Accordingly, the current collector 2 with at least one layer of compressed CNT 12 to a plurality of layers of compressed CNT 12 disposed thereon may be used as a charge storage device (i.e., a high-power electrode). Generally, such embodiments of the high-power electrode are particularly well adapted for use in a capacitor, or an ultracapacitor. In addition to some of the foregoing mentioned advantages (higher gravimetric and volumetric power densities, low internal resistance and high voltage delivery), less electrolyte is required. Thus, users are provided with an improved performance energy storage that is less expensive to manufacture.

[0035] In other embodiments, consideration may be given to the particular properties of the base material 6, the catalyst 7, the conductor layer 3 and the bonding layers 4. That is, for example, if the foregoing fabrication is completed in a substantially oxygen-free environment, it is expected that other materials and processes may be used (or omitted) to provide for the current collector 2 with at least one layer of compressed CNT 12 to a plurality of layers of compressed CNT 12. Accordingly, these and other embodiments as may be devised by one skilled in the art are within the ambit of the invention and the teachings herein.

[0036] In further embodiments, at least one other layer may be included. For example, an ohmic contact layer may be included, and provided to enhance ohmic contact between the another bonding layer 4, the compressed CNT 12 (which also may be referred to as an “energy storage layer,” an “active layer” and by other similar terms) or another layer. In another example, an adhesion layer may be included, and provided to enhance adhesion between the another bonding layer 4 and the compressed CNT 12, or another layer. Materials in the additional or optional layers may be chosen according to at least one property, such as electrical conductivity, compatibility and the like.

[0037] With regard to the ohmic contact layer, the ohmic contact layer may be useful for achieving an ohmic contact with the carbonaceous layer. If the ohmic contact layer will be exposed to the electrolyte in which the electrode will ultimately be immersed (such as through a porous carbonaceous layer), the ohmic contact layer material should be chosen for good electric compliance, usually a suitably low reaction rate, with that particular embodiment of electrolyte. The ohmic contact layer may be deposited onto the carbonaceous layer using magnetron sputtering, thermal evaporation, or a similar process. Exemplary materials that may be used in the ohmic

contact layer are aluminum (Al), tantalum (Ta), and platinum (Pt). In general, a thickness of this ohmic contact layer varies in the range of from about 1 nm to about 10 μm .

[0038] With regard to the “adhesion layer,” this layer may be used to improve adhesion between the current collector **2** and another layer. The adhesion layer may be deposited onto the current collector **2** using magnetron sputtering or a similar process. Typical materials included in the adhesion layer are titanium (Ti), chromium (Cr), titanium-tungsten (Ti—W) or a combination of those materials. If the conductivity of the material making up the adhesion layer is relatively low, then its thickness should be limited to achieve suitable current handling performance. In general, a thickness of this adhesion layer varies between about 1 nanometer (nm) and about 100 (nm).

[0039] Having disclosed aspects of embodiments of the production apparatus and techniques for fabricating aggregates of carbon nanotubes, it should be recognized that a variety of embodiments may be realized. Further a variety of techniques of fabrication may be practiced. For example, steps of fabrication may be adjusted, as well as techniques for joining, materials and chemicals used and the like.

[0040] As a matter of convention, it should be considered that the terms “may” as used herein is to be construed as optional; “includes,” “has” and “having” are to be construed as not excluding other options (i.e., steps, materials, components, compositions, etc., . . .); “should” does not imply a requirement, rather merely an occasional or situational preference. Other similar terminology is likewise used in a generally conventional manner.

[0041] While the invention has been described with reference to exemplary embodiments, it will be understood that various changes may be made and equivalents may be substituted for elements thereof without departing from the scope of the invention. For example, in some embodiments, one of the foregoing layers may include a plurality of layers there within. In addition, many modifications will be appreciated to adapt a particular instrument, situation or material to the teachings of the invention without departing from the essen-

tial scope thereof. Therefore, it is intended that the invention not be limited to the particular embodiment disclosed as the best mode contemplated for carrying out this invention, but that the invention will include all embodiments falling within the scope of the appended claims.

1-11. (canceled)

12. A method for fabricating an aligned carbon nanotube aggregate for an electrode, the method comprising:

selecting a substrate; growing the aligned carbon nanotube aggregate onto the substrate; and

disposing a bonding layer onto the aligned carbon nanotube aggregate following the growth thereof, wherein the bonding layer is adapted for bonding with a current collector of the electrode.

13. The method as in claim **12**, further comprising compressing the aligned carbon nanotubes aggregate to provide a compressed carbon nanotube aggregate.

14. The method as in claim **12**, wherein the bonding layer comprises at least one of a combination of iron, chromium and nickel; aluminum; gold; silver; palladium; tin; platinum and a combination of any of the foregoing materials.

15. The method as in claim **12**, further comprising treating the aligned carbon nanotube aggregate to facilitate removal from the substrate.

16. The method as in claim **15**, wherein the treating comprises oxidizing the carbon nanotube aggregate.

17. An ultracapacitor comprising: at least one electrode comprising a current collector comprising at least one layer of compressed carbon nanotubes disposed thereon.

18. The ultracapacitor as in claim **17**, wherein the electrode comprises a bonding layer disposed between the current collector and the compressed carbon nanotubes.

19. A method for fabricating an ultracapacitor, the method comprising: selecting an electrode comprising at least one layer of compressed carbon nanotubes disposed thereon; and including the electrode in the ultracapacitor.

20. The method as in claim **19**, further comprising incorporating an electrolyte in the ultracapacitor.

* * * * *