



US 20150184876A1

(19) **United States**

(12) **Patent Application Publication**  
Vandermeulen et al.

(10) **Pub. No.: US 2015/0184876 A1**

(43) **Pub. Date: Jul. 2, 2015**

(54) **METHODS AND SYSTEMS FOR DESICCANT AIR CONDITIONING**

(60) Provisional application No. 61/430,692, filed on Jan. 7, 2011, provisional application No. 61/348,076, filed on May 25, 2010.

(71) Applicant: **7AC Technologies, Inc.**, Beverly, MA (US)

(72) Inventors: **Peter F. Vandermeulen**, Newburyport, MA (US); **Jack I. Hanoka**, Brookline, MA (US)

(73) Assignee: **7AC TECHNOLOGIES, INC.**, Beverly, MA (US)

(21) Appl. No.: **14/645,760**

(22) Filed: **Mar. 12, 2015**

**Related U.S. Application Data**

(62) Division of application No. 13/115,789, filed on May 25, 2011.

**Publication Classification**

(51) **Int. Cl.**  
*F24F 3/14* (2006.01)

(52) **U.S. Cl.**  
CPC ..... *F24F 3/1417* (2013.01); *F24F 2003/144* (2013.01); *F24F 2003/1458* (2013.01)

(57) **ABSTRACT**

Methods and systems are provided for air conditioning, capturing combustion contaminants, desalination, and other processes using liquid desiccants.

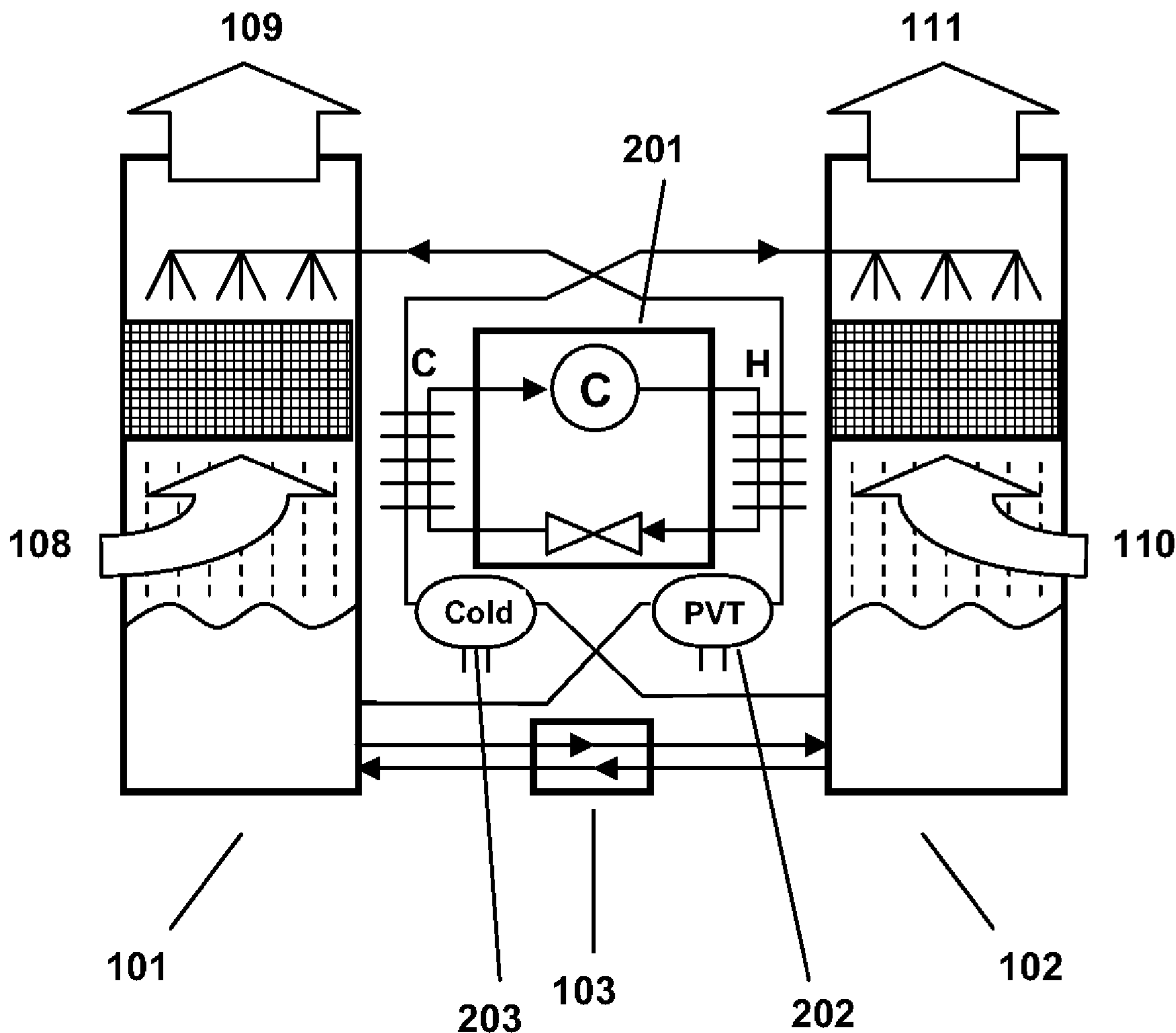

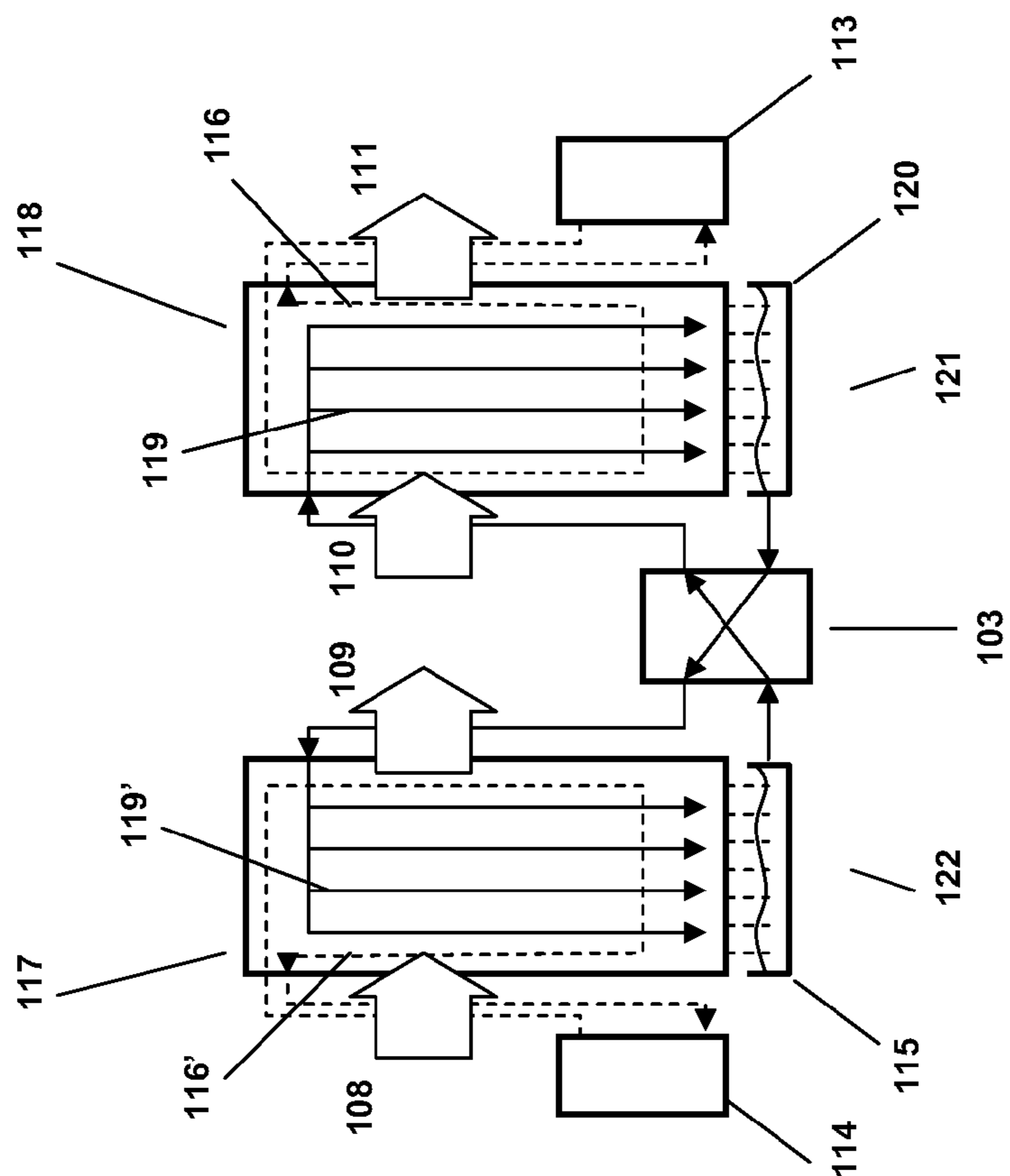

PRIOR ART

FIG. 1B

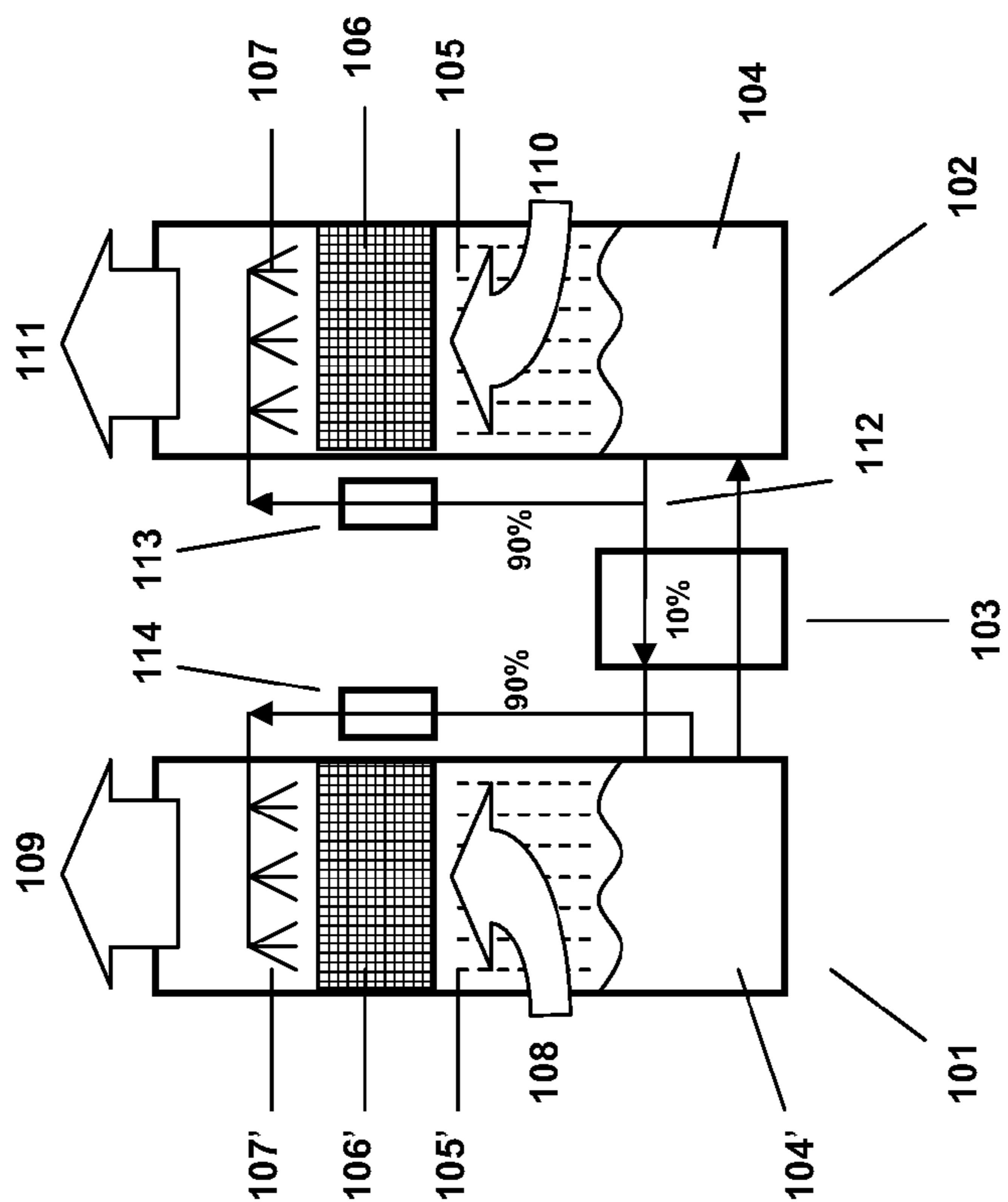

PRIOR ART

FIG. 1A

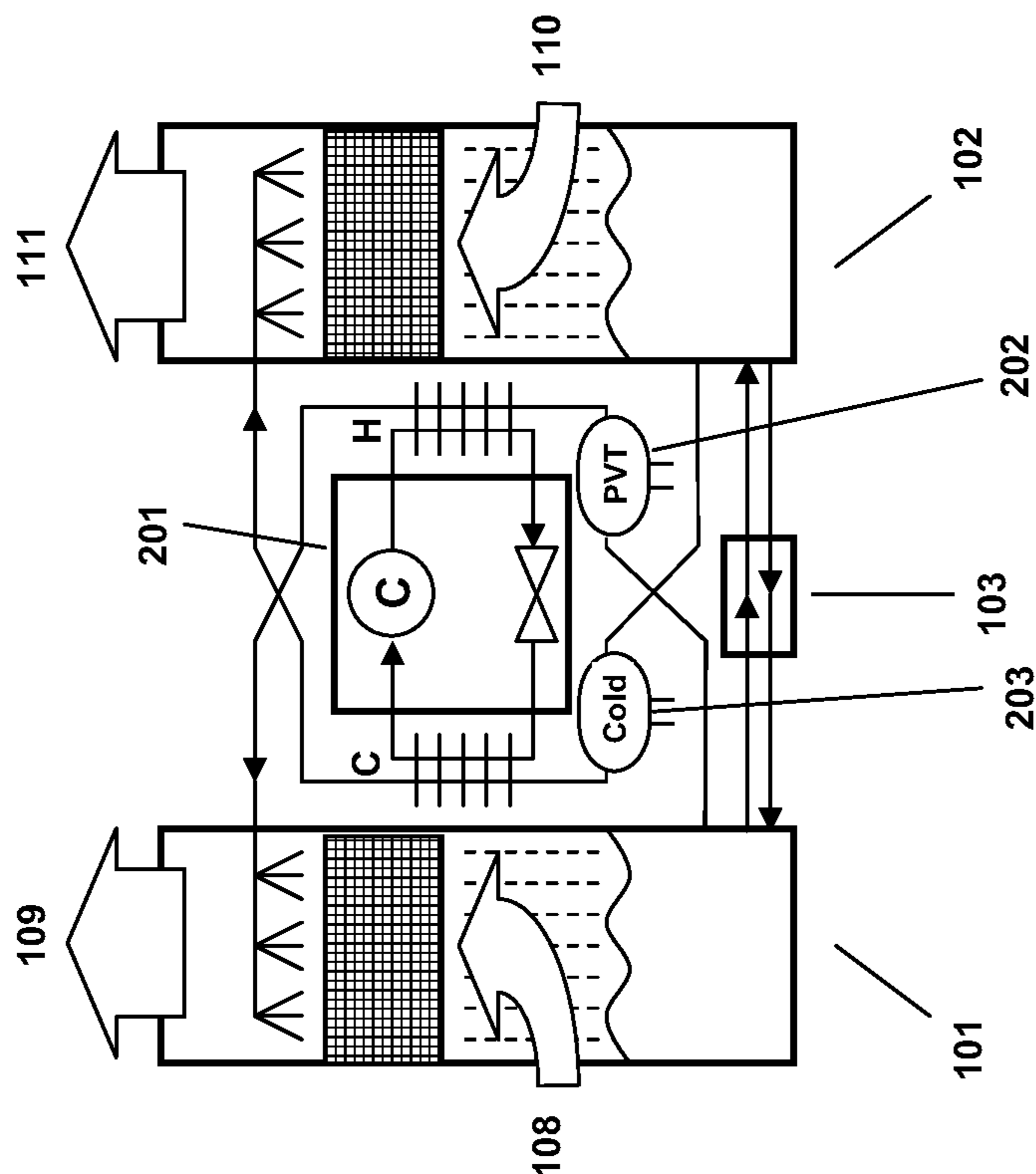

FIG. 2B

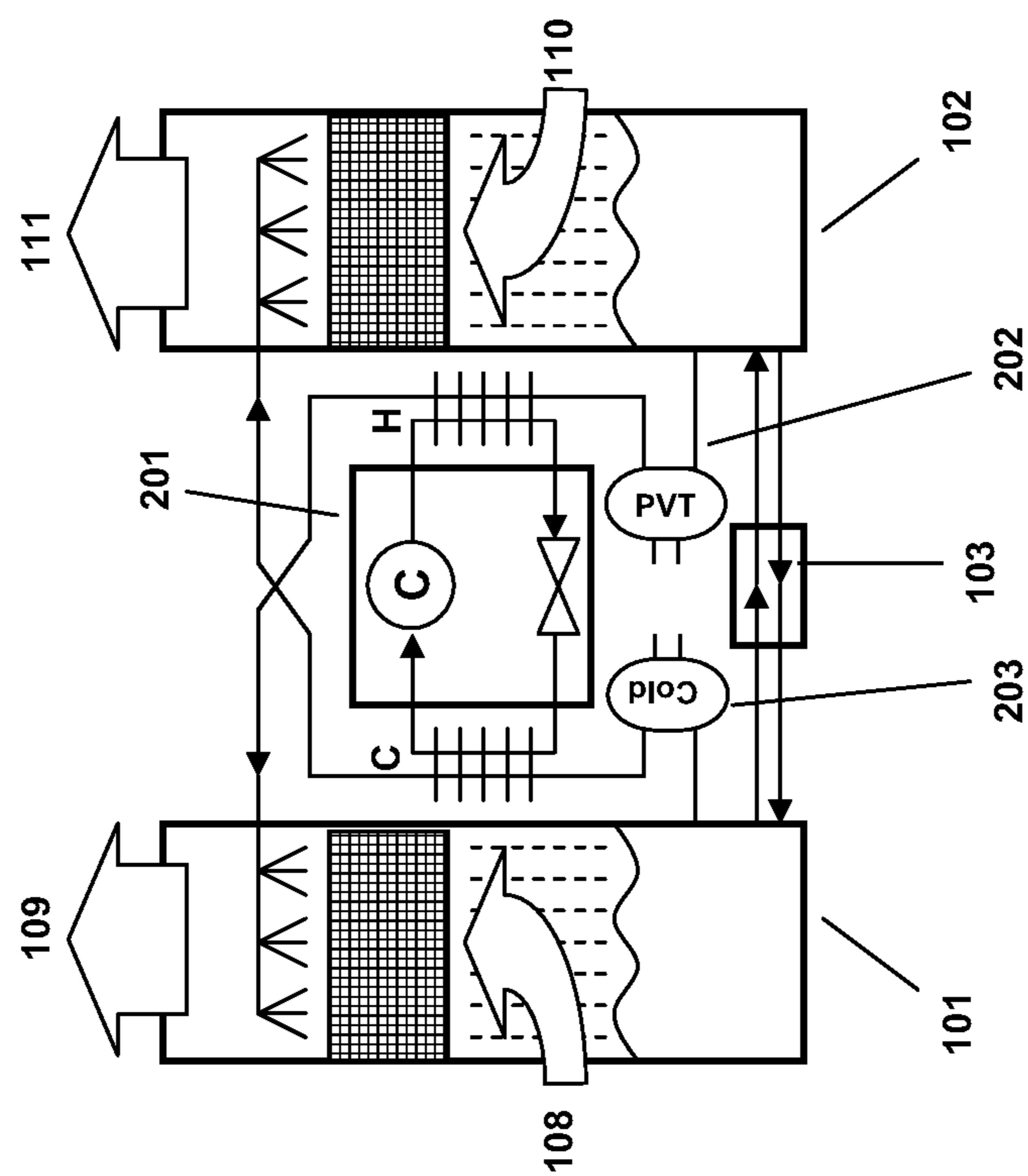

FIG. 2A

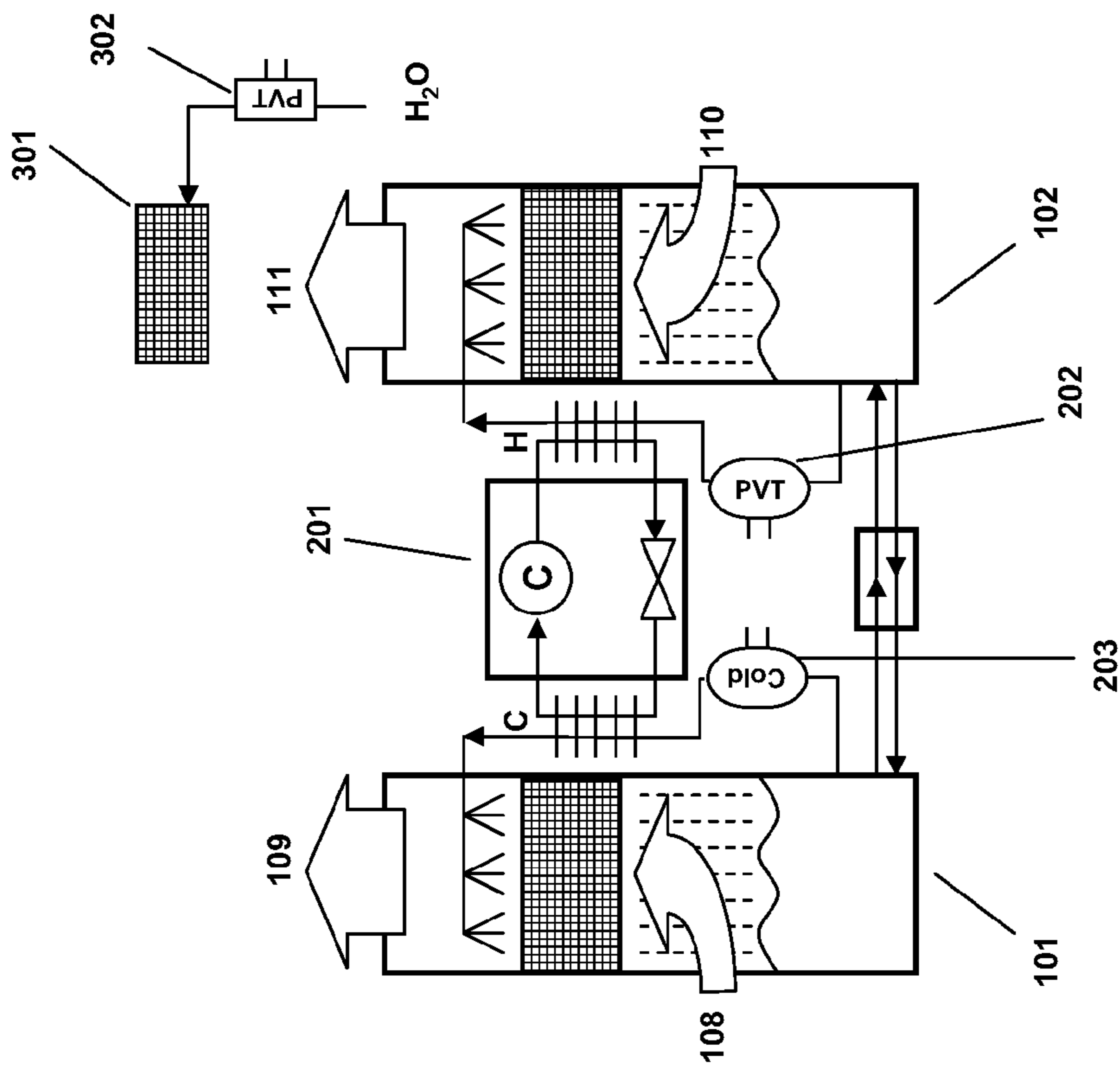

FIG. 3B

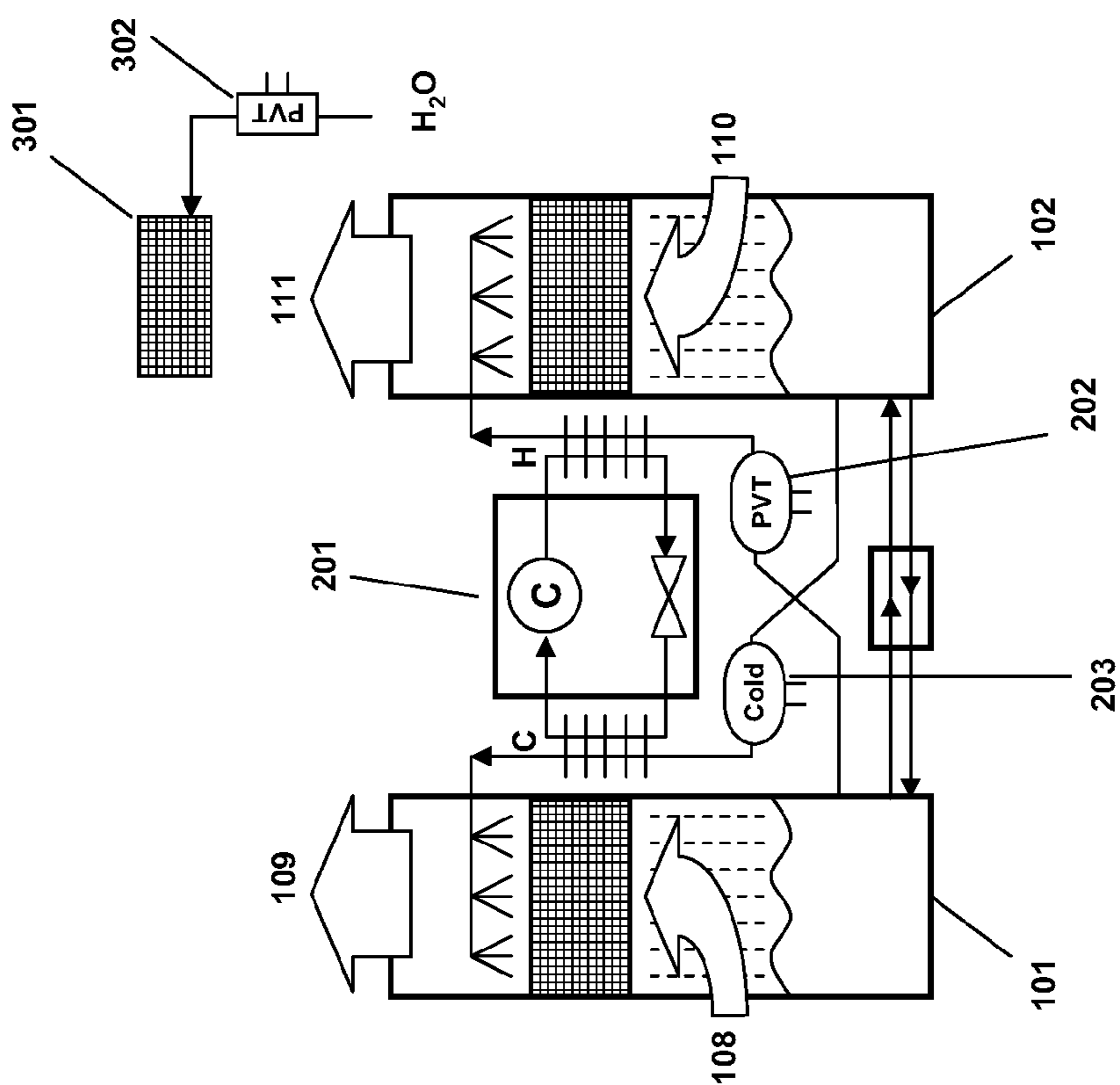

FIG. 3A

 : connection to PVT modules

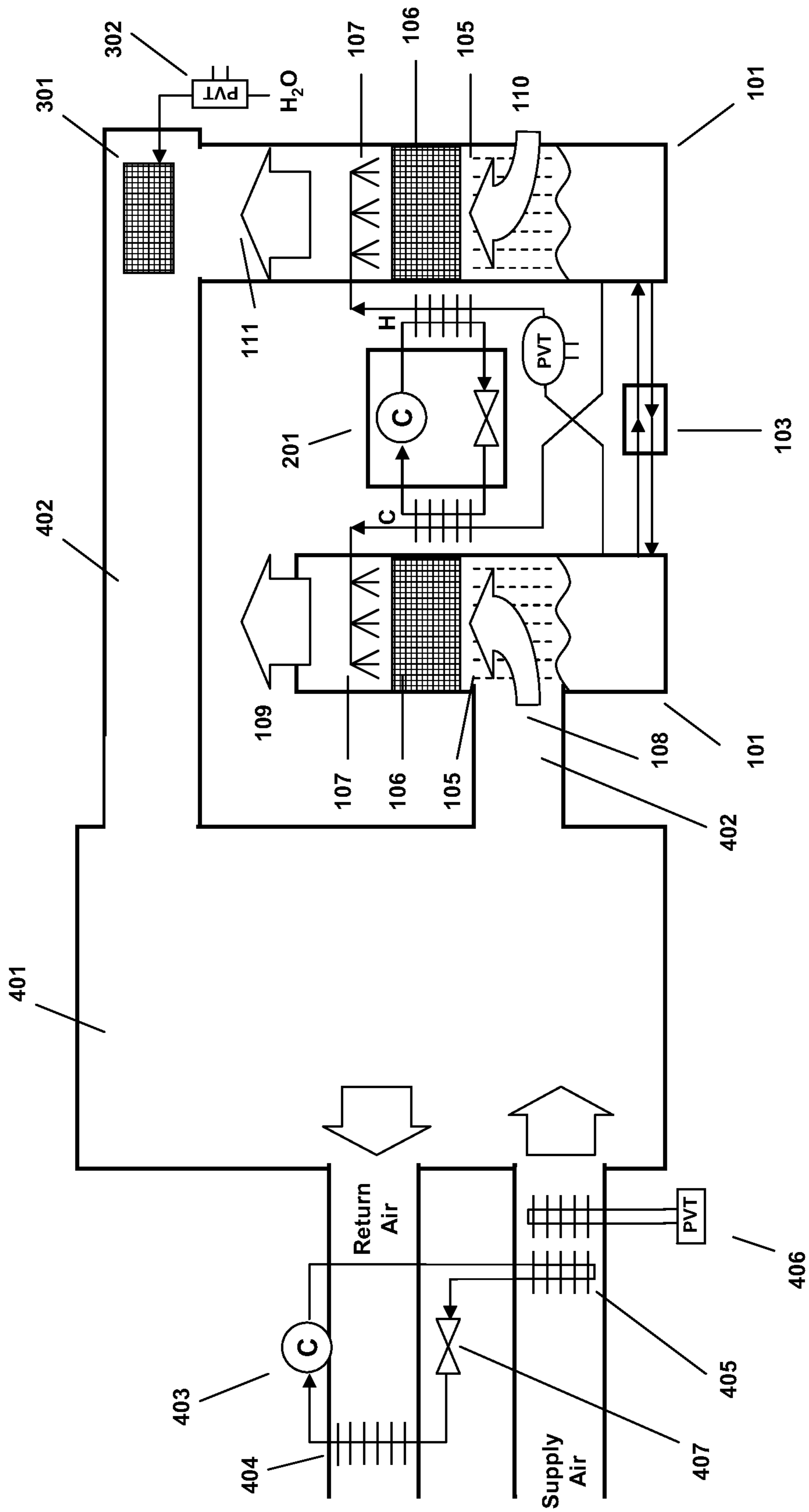

FIG. 4

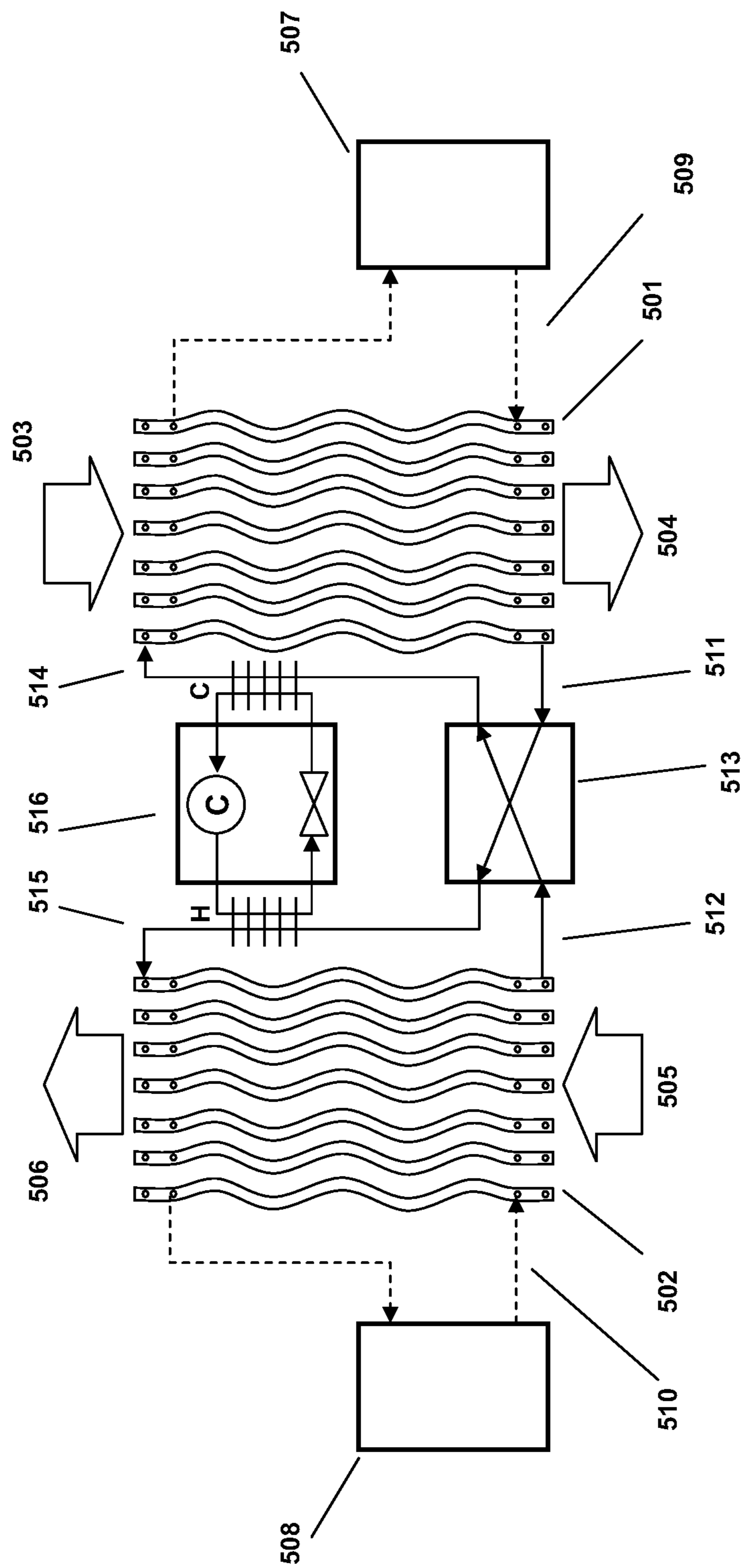

FIG. 5

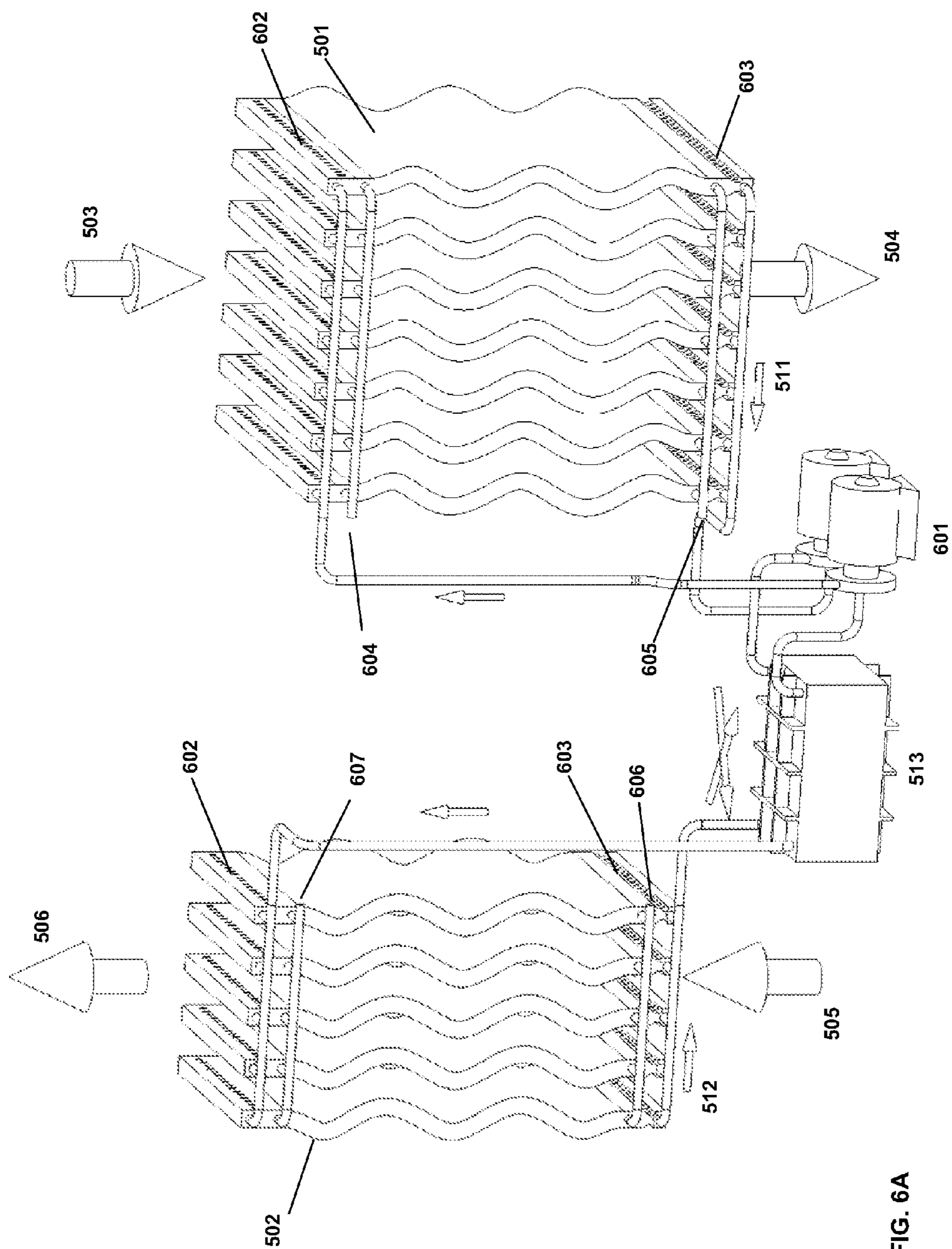
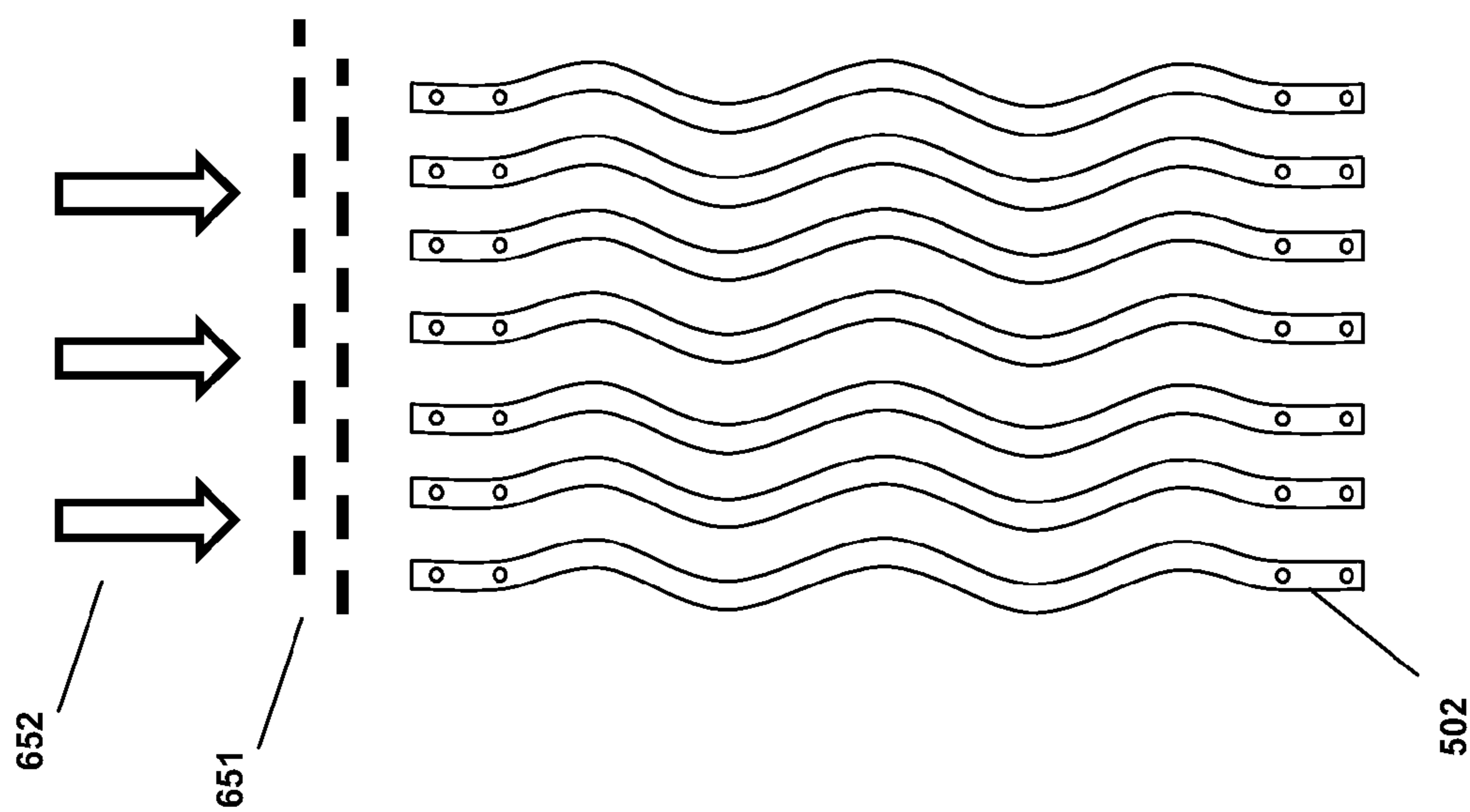

FIG. 6A

FIG. 6B





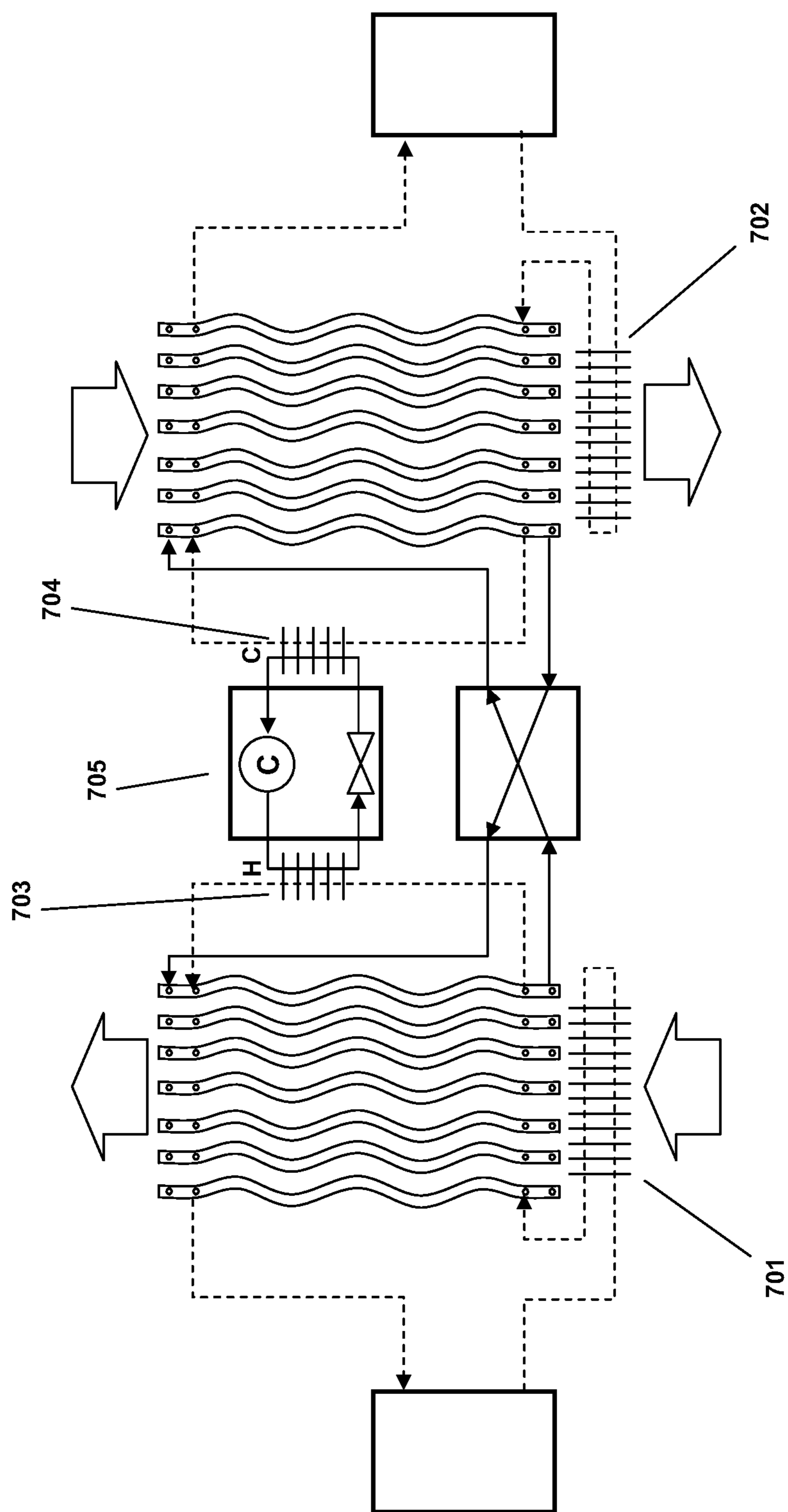

FIG. 7

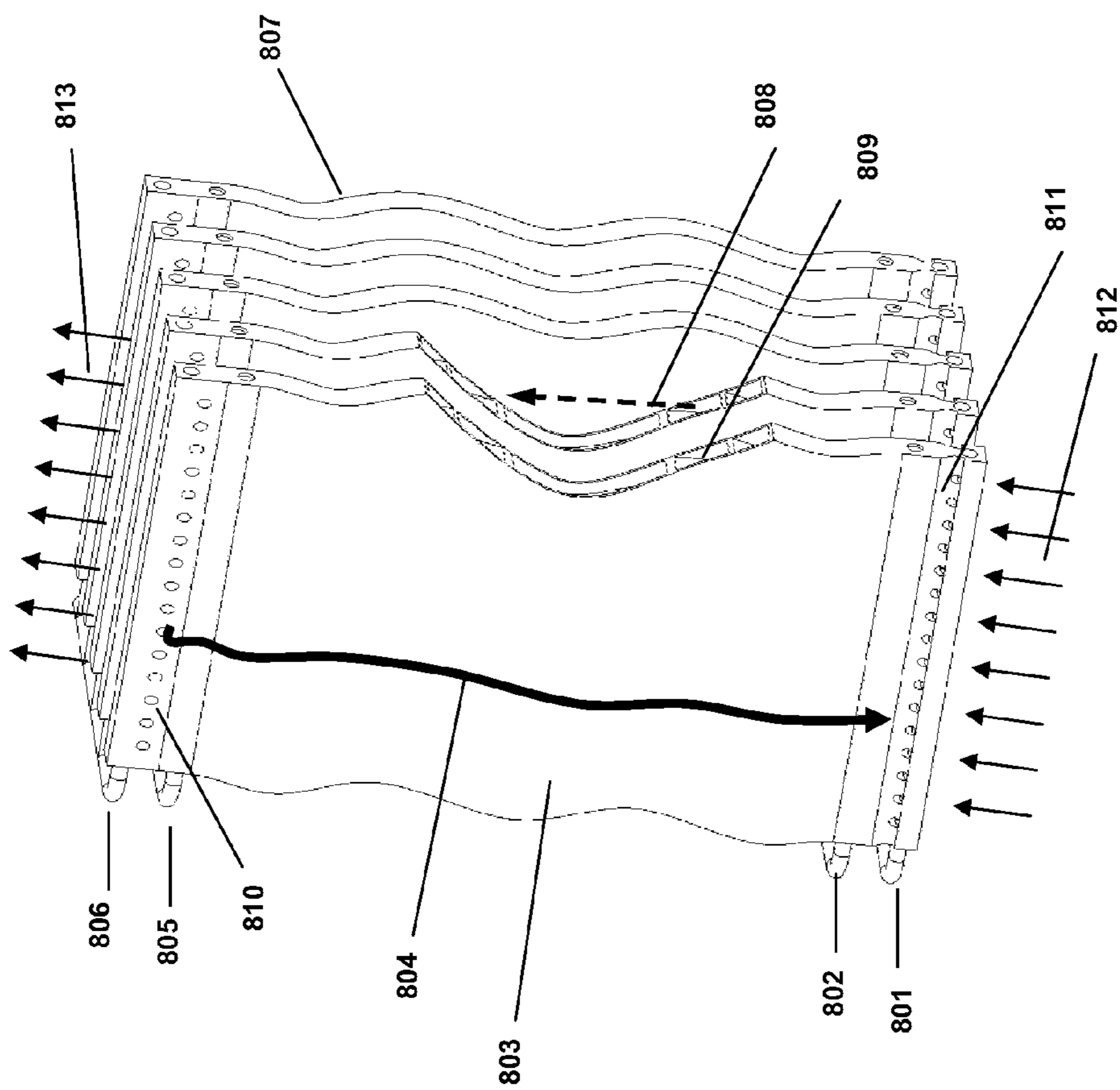

FIG. 8

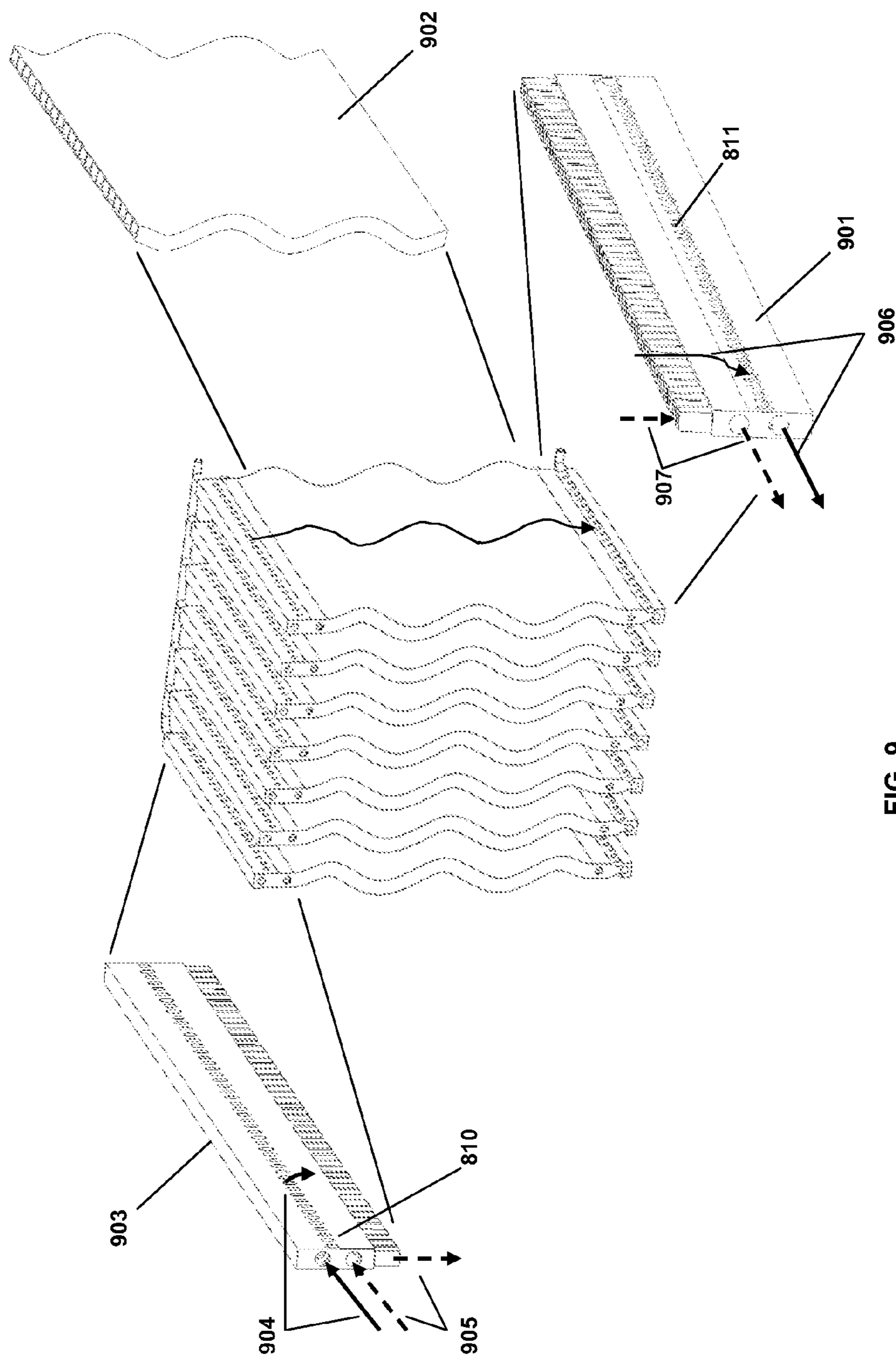

FIG. 9

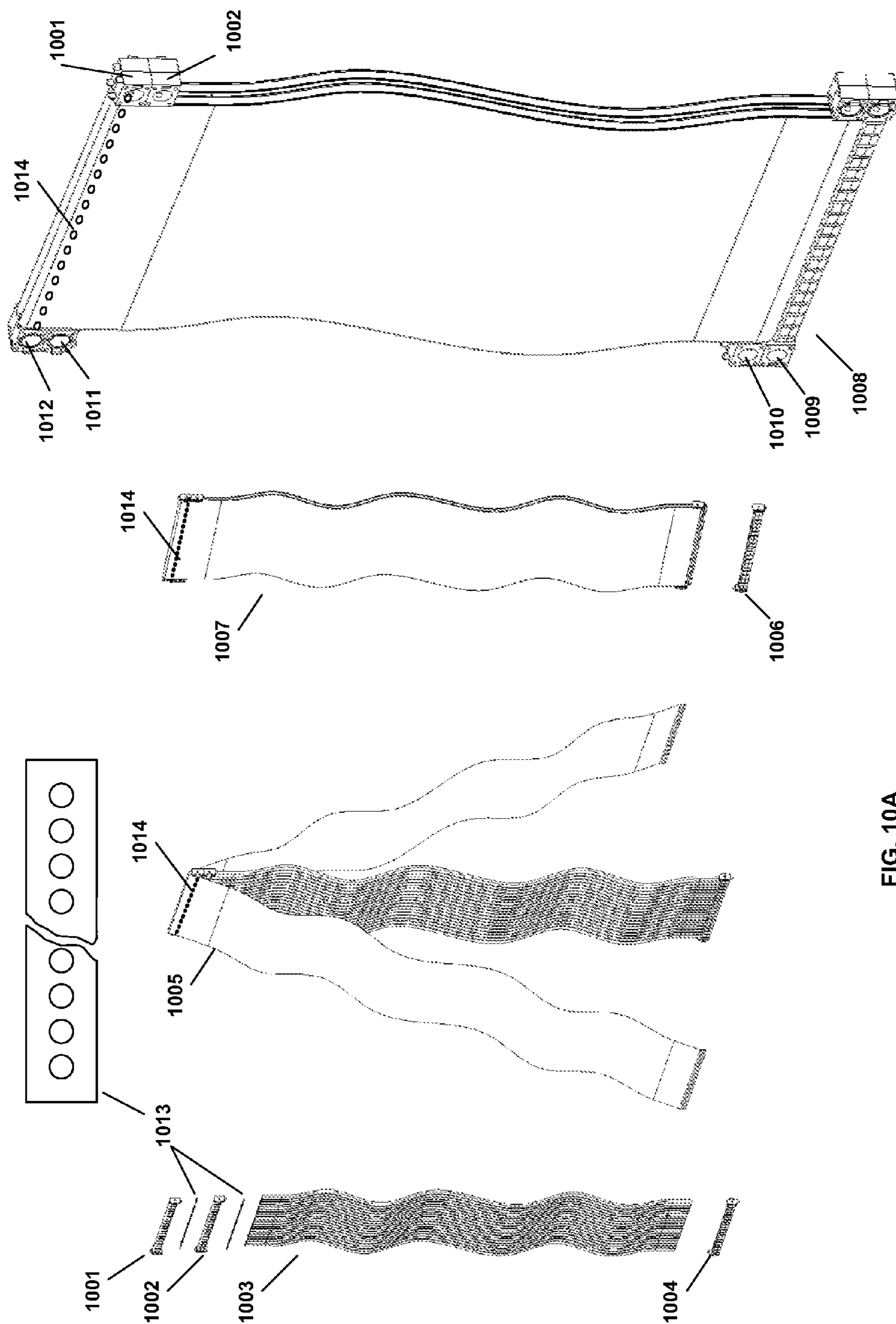

FIG. 10A

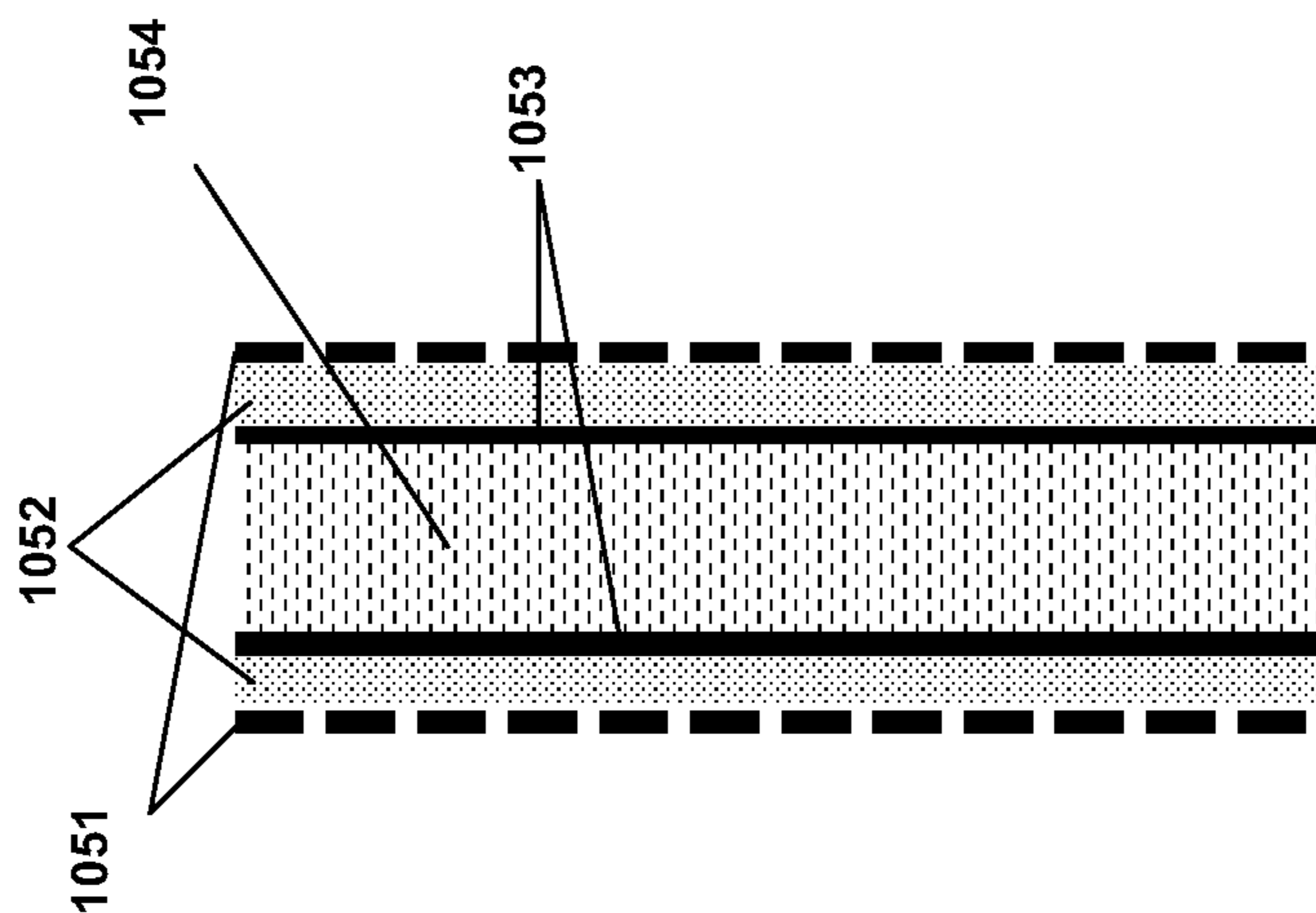

FIG. 10B

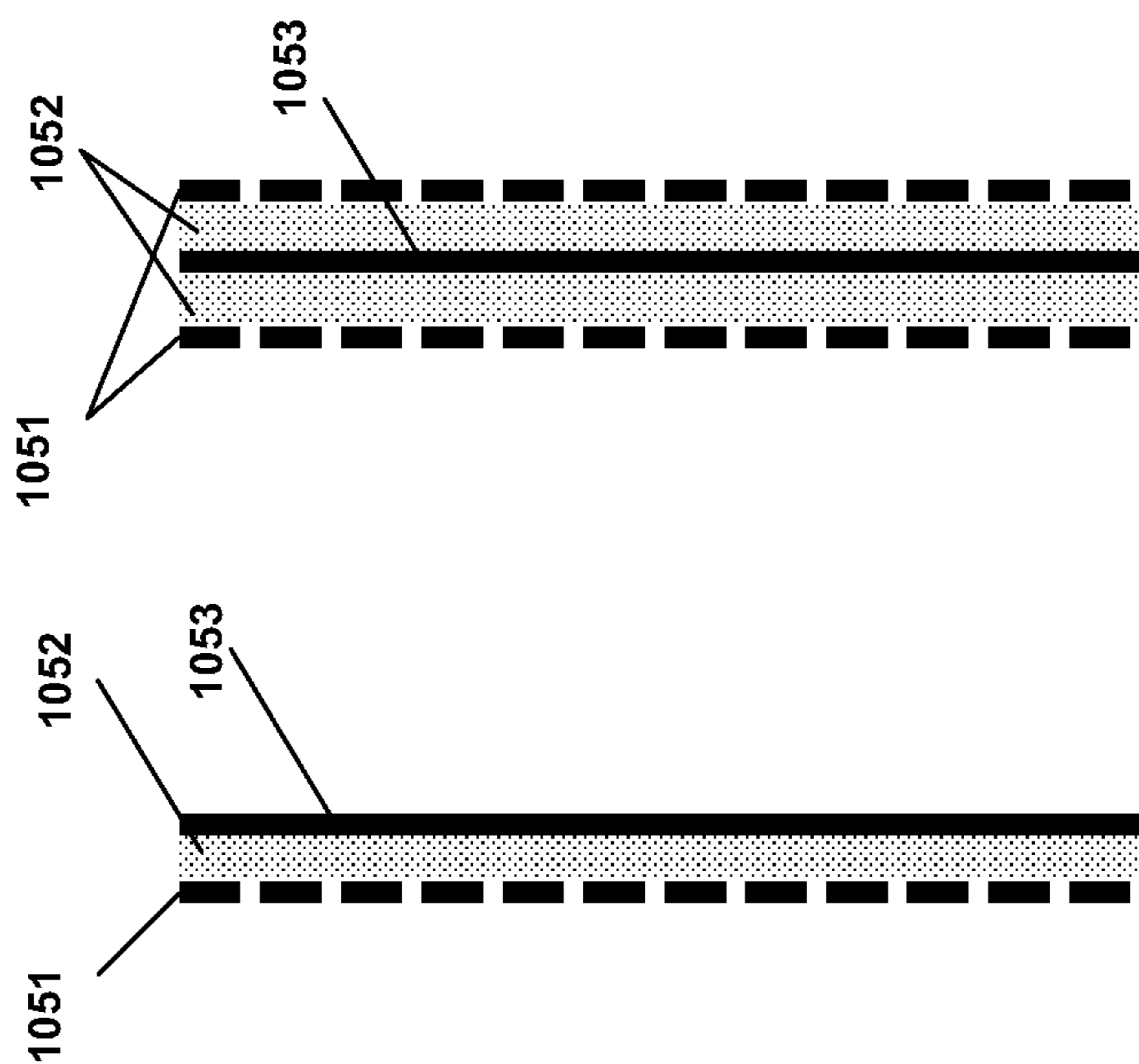

FIG. 10C

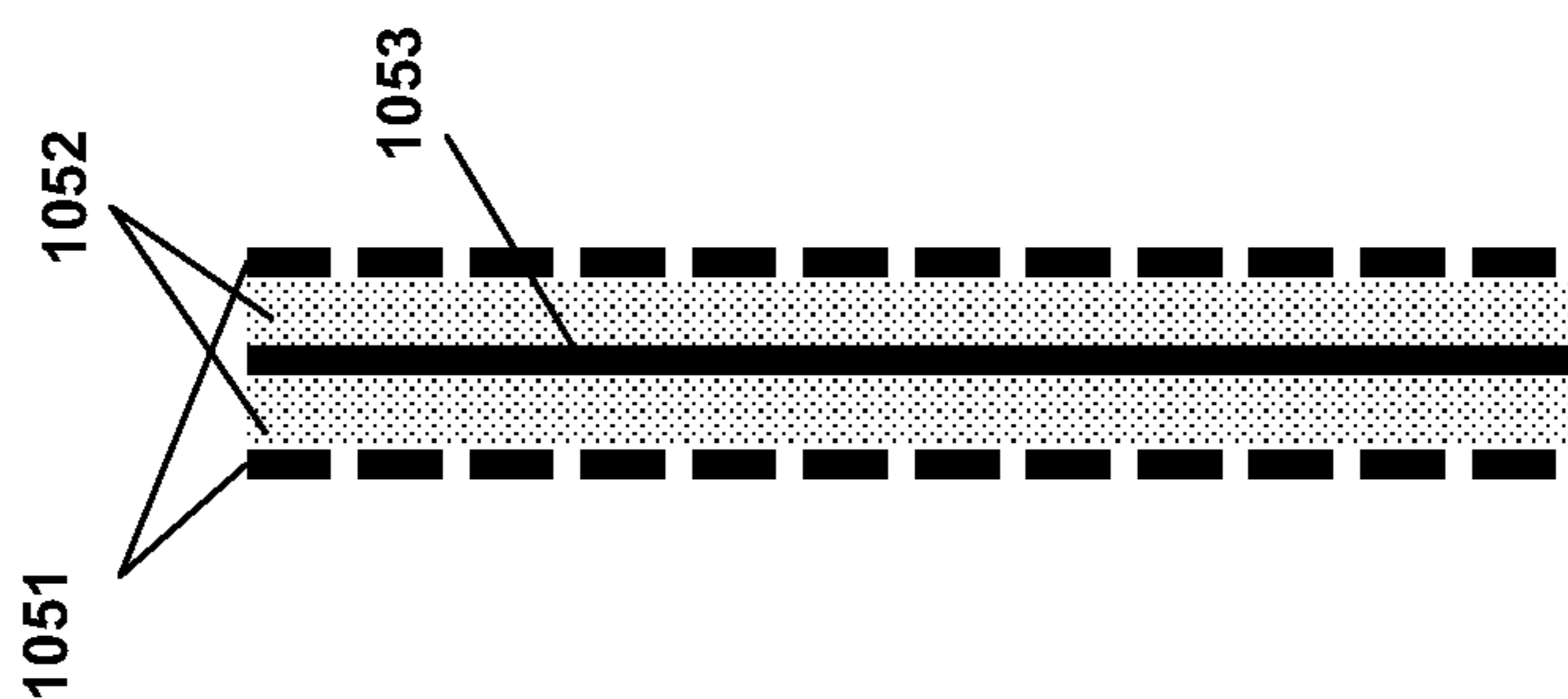

FIG. 10D

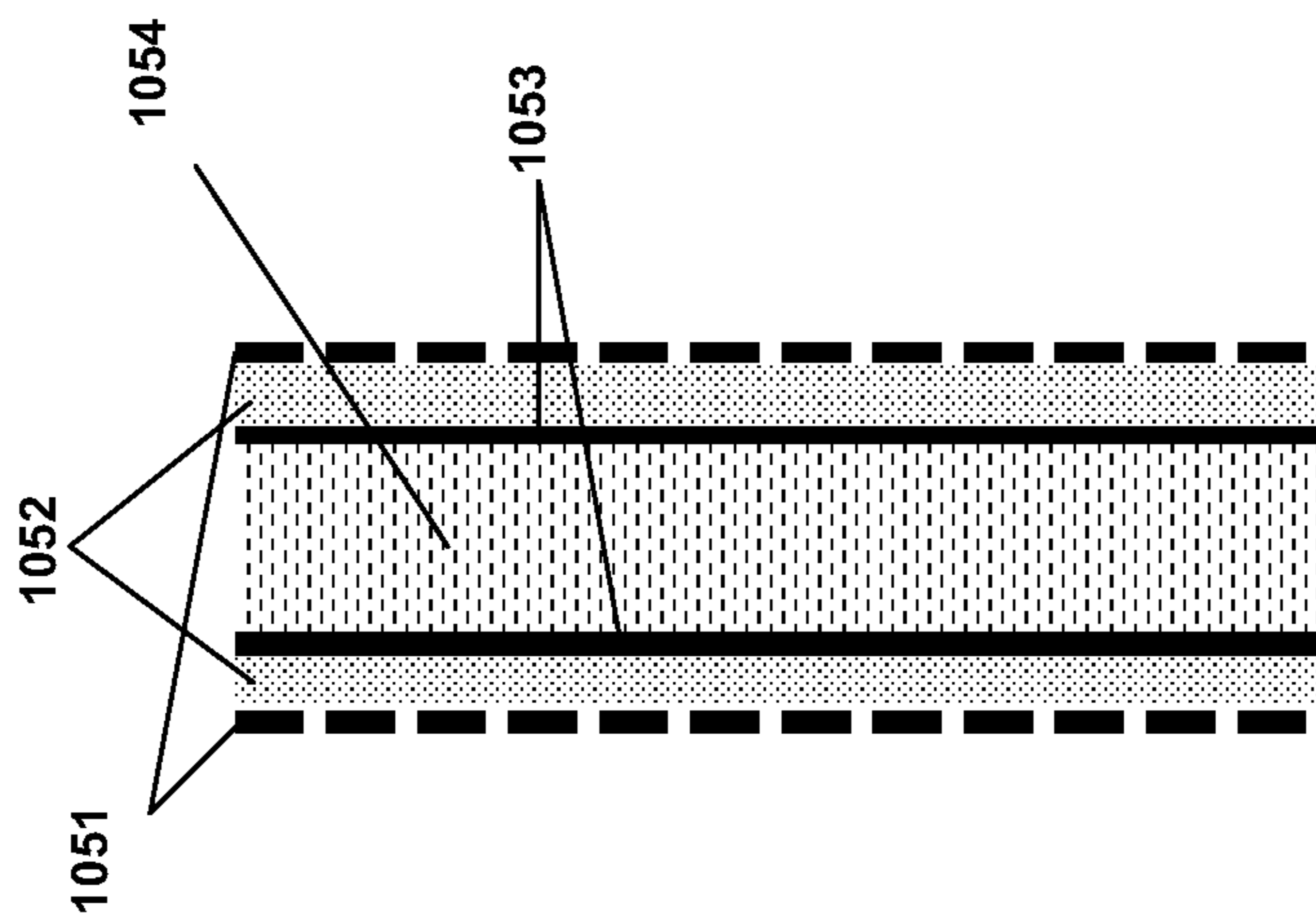
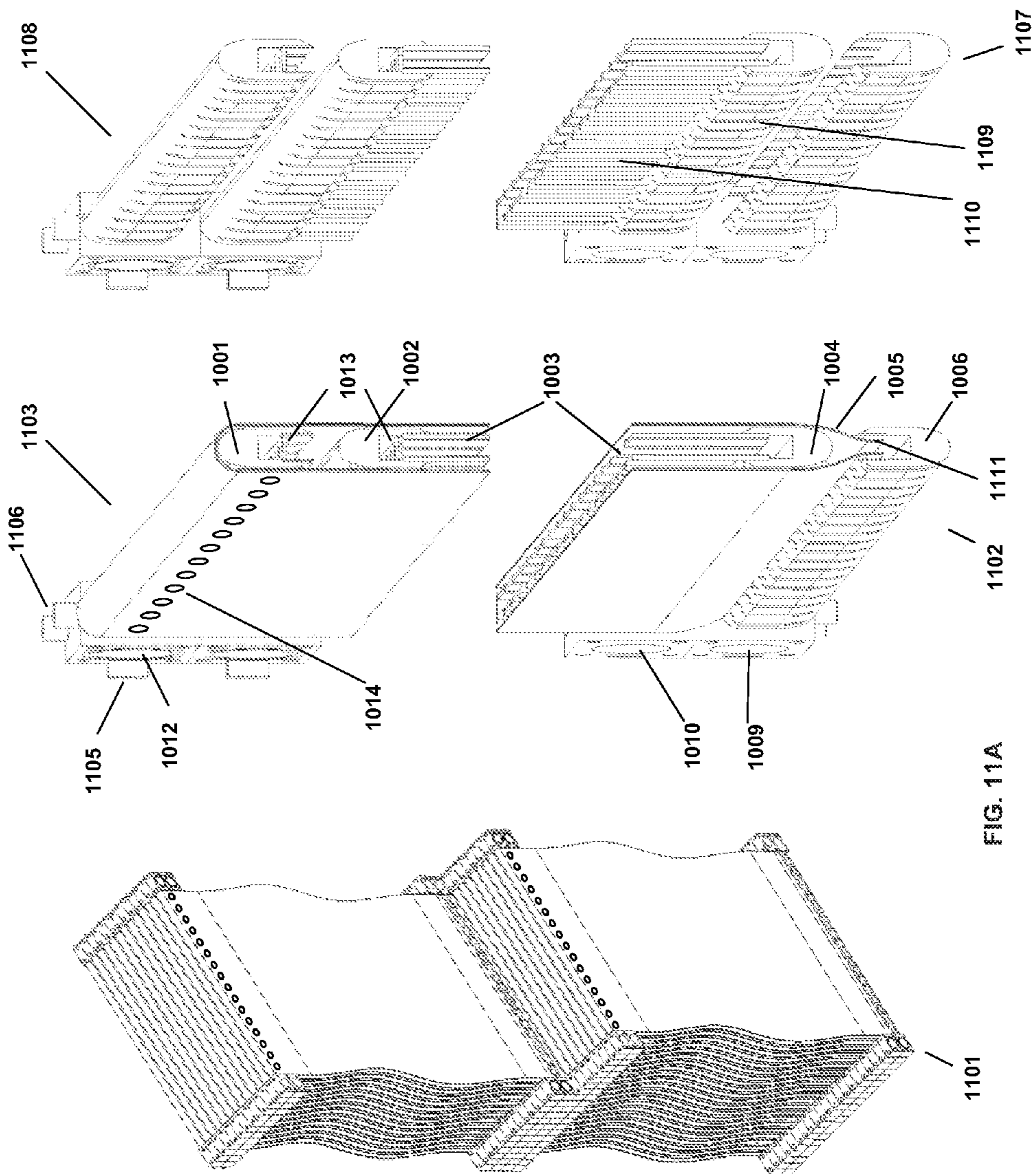

FIG. 10E



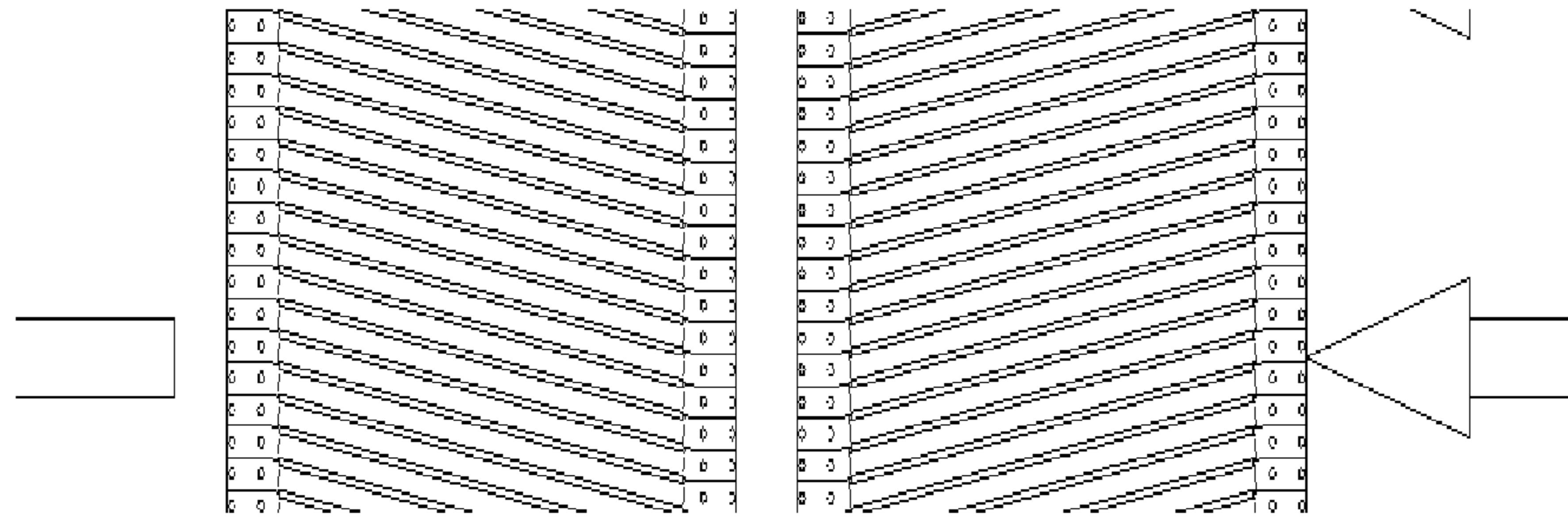

FIG. 11C

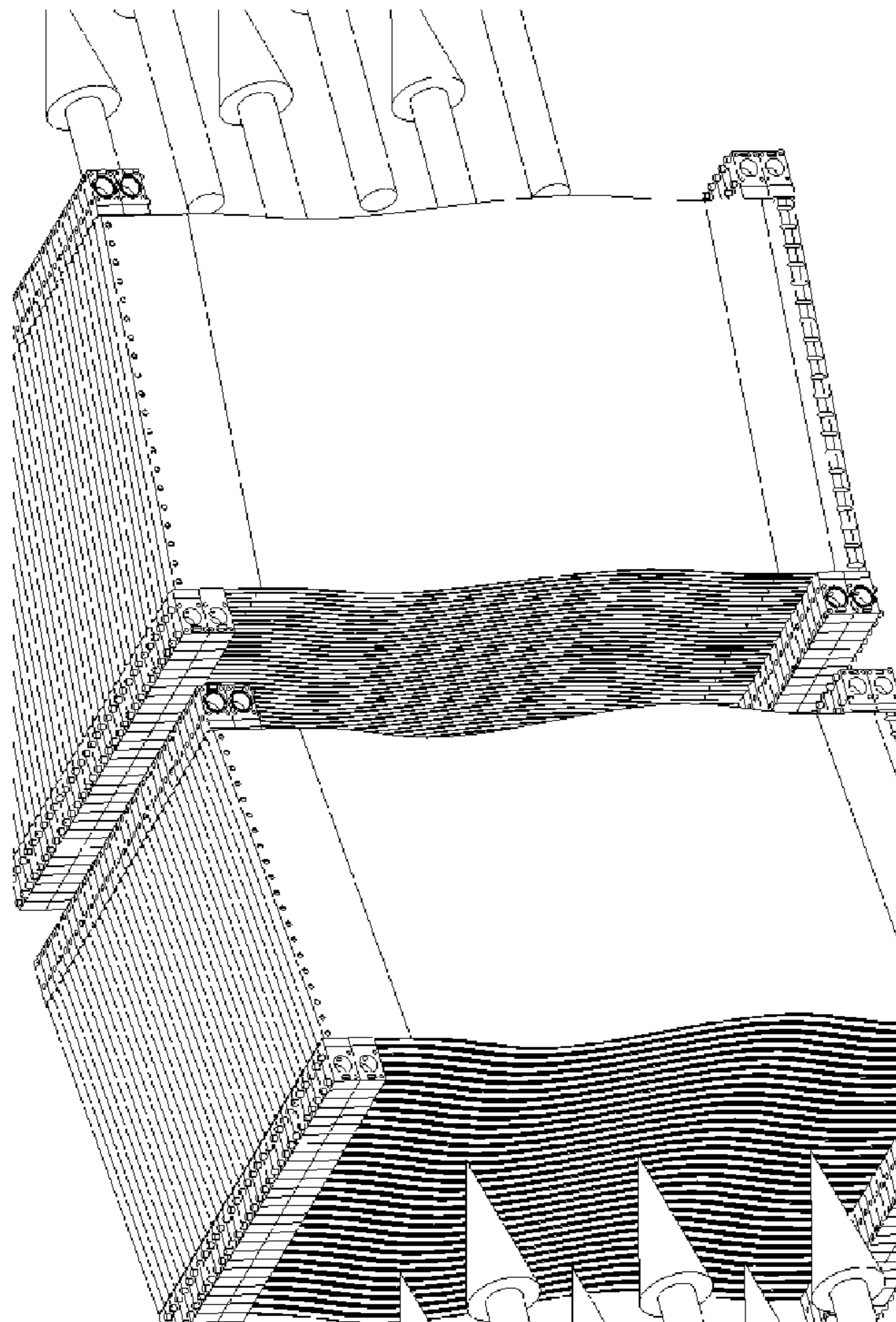

FIG. 11B

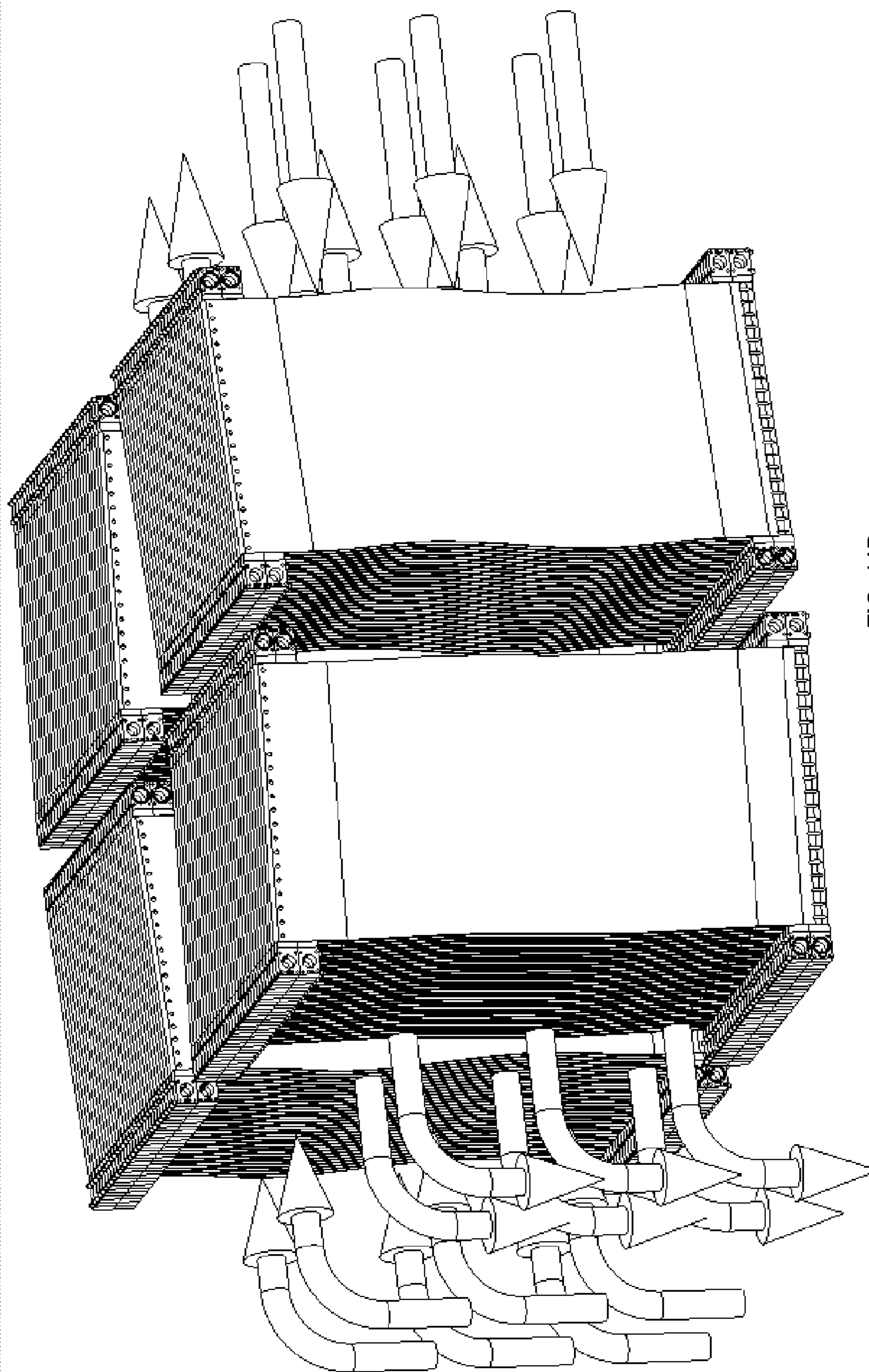

FIG. 11D



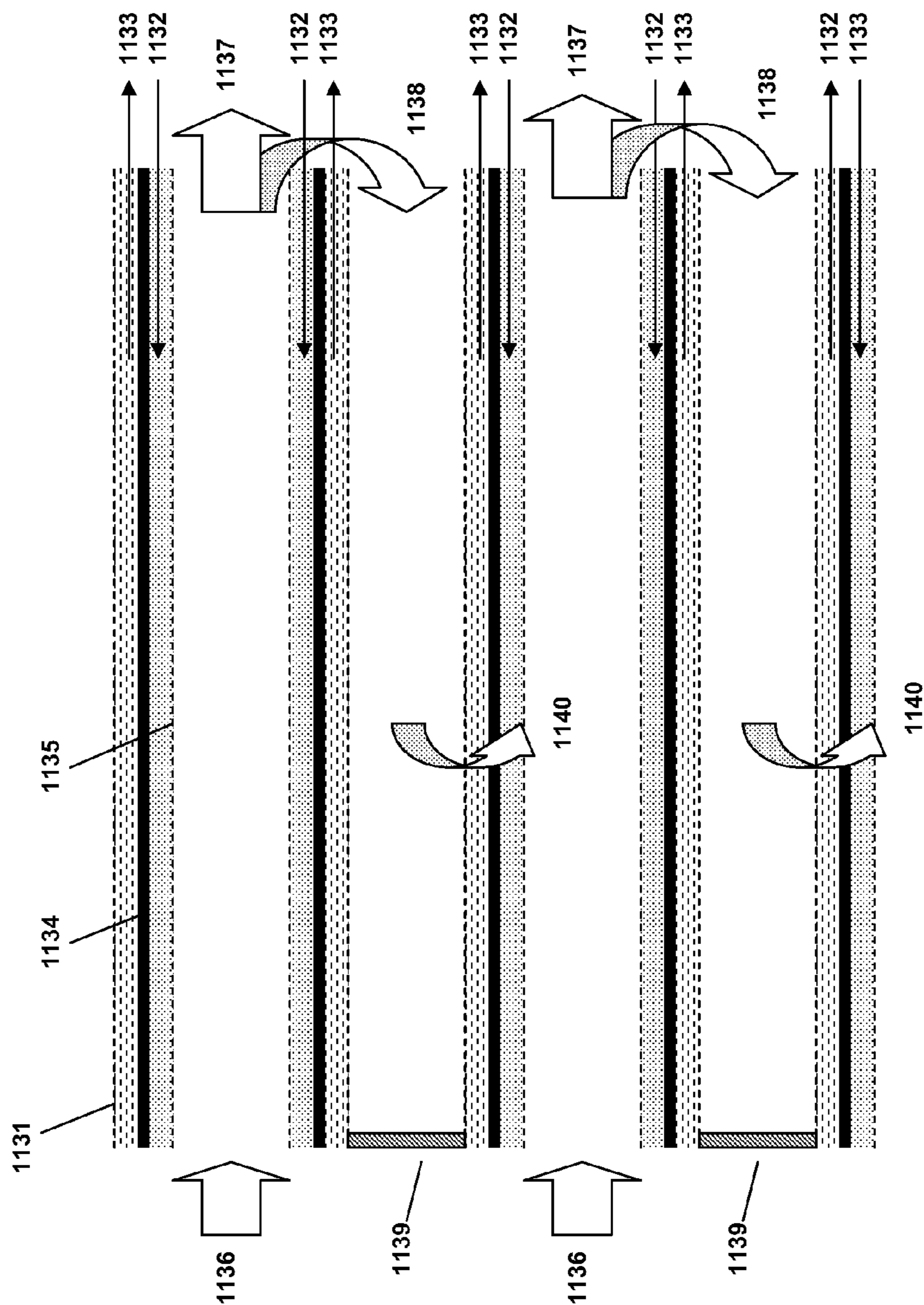
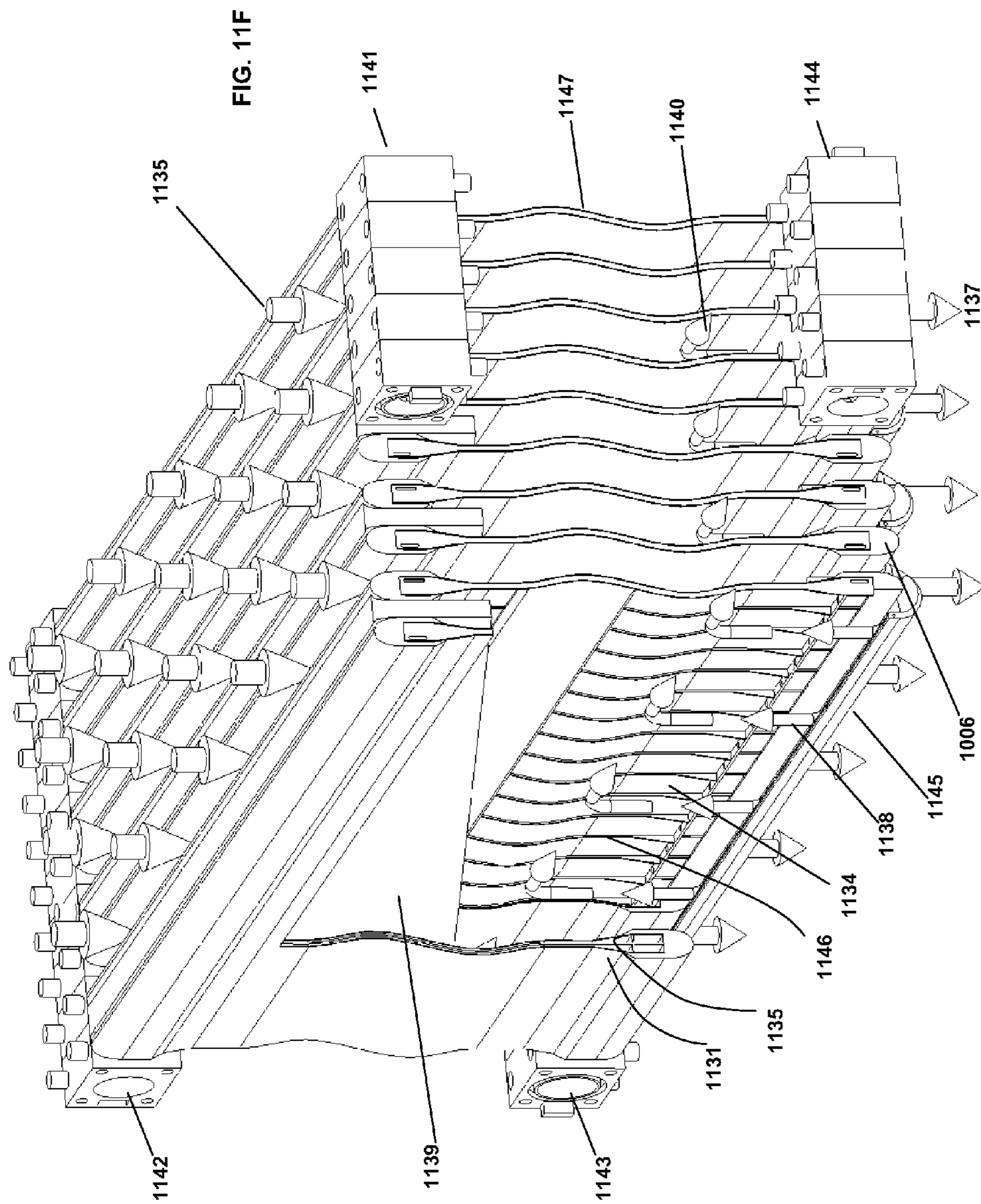

FIG. 11E  
PRIOR ART



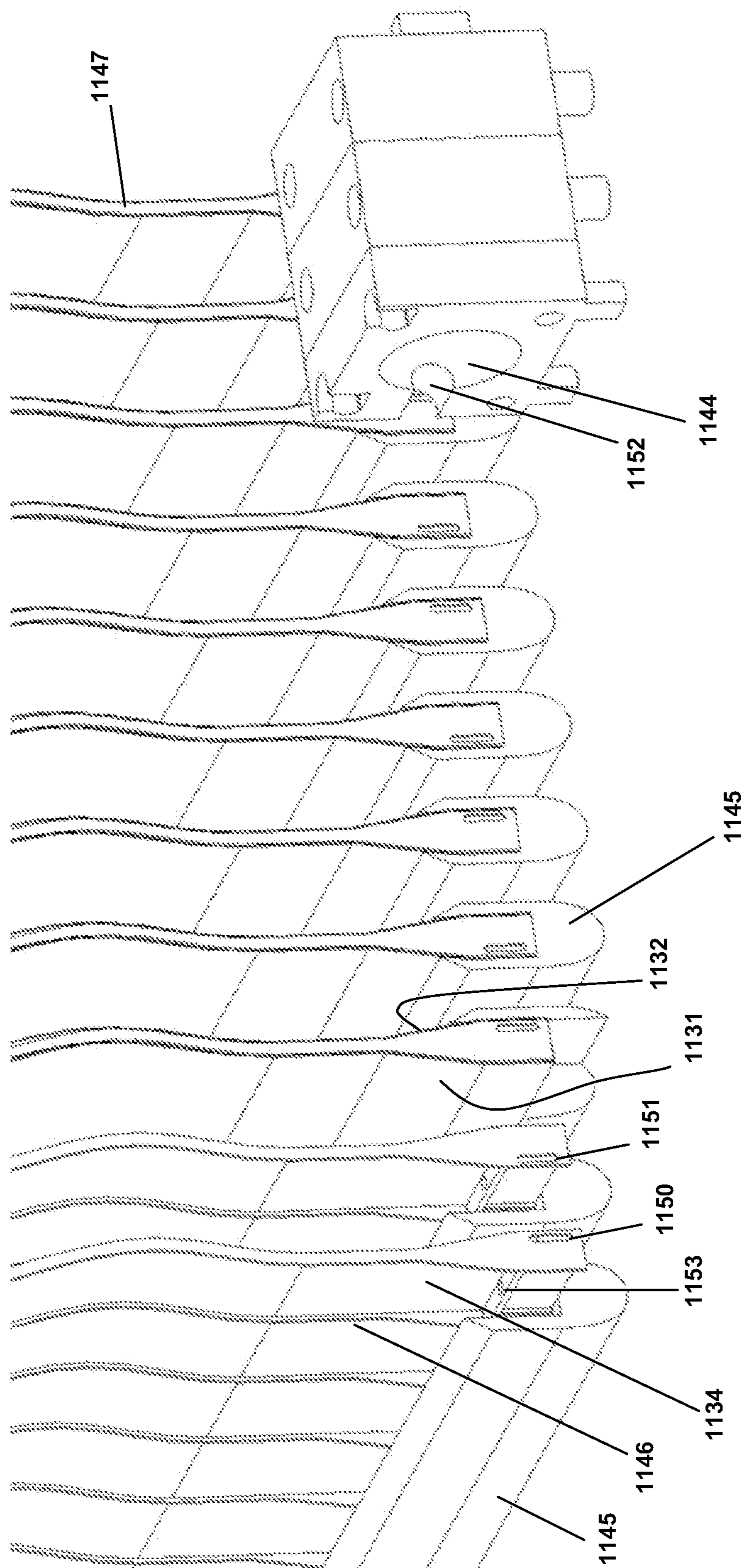
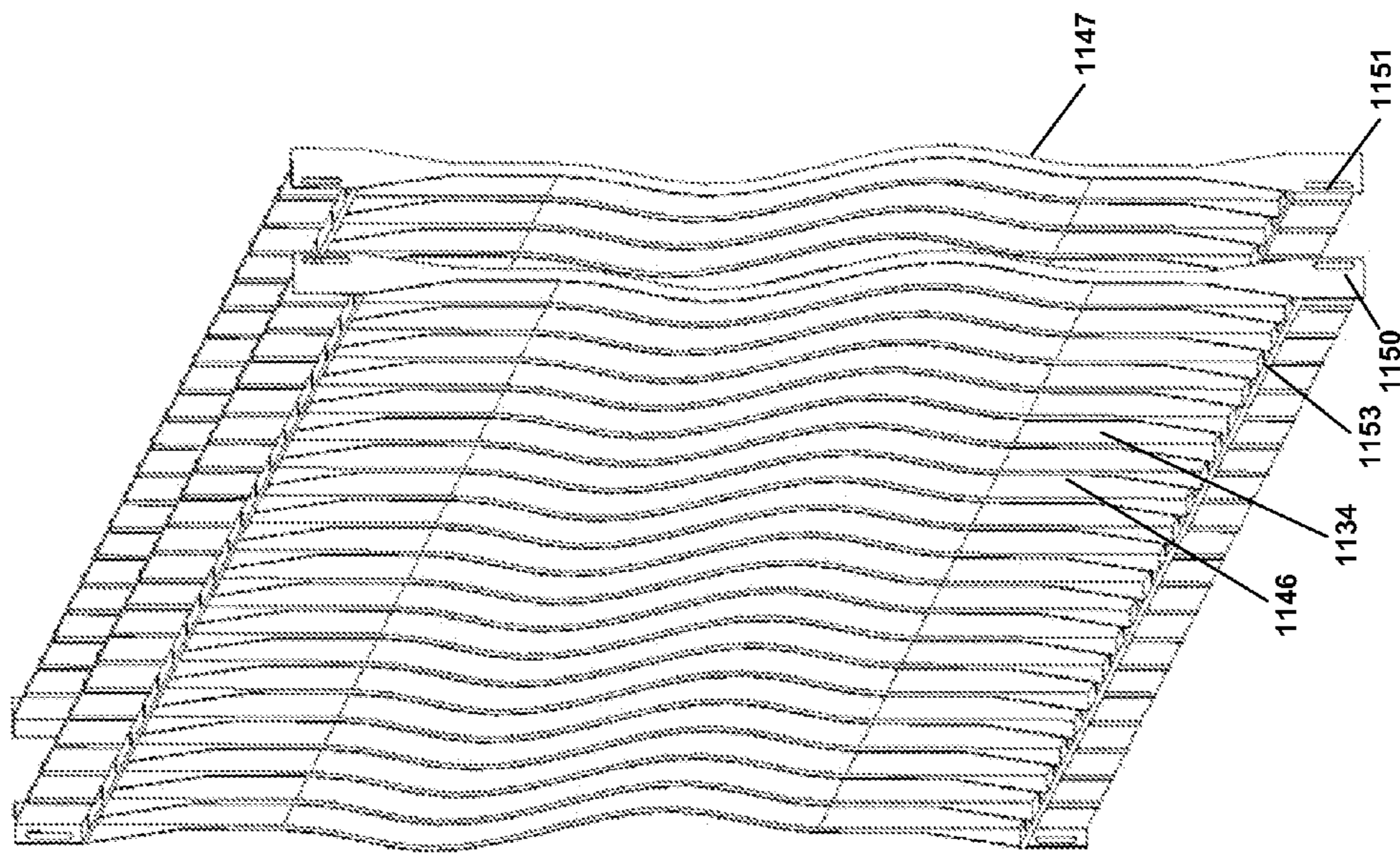

FIG. 11G

FIG. 11H



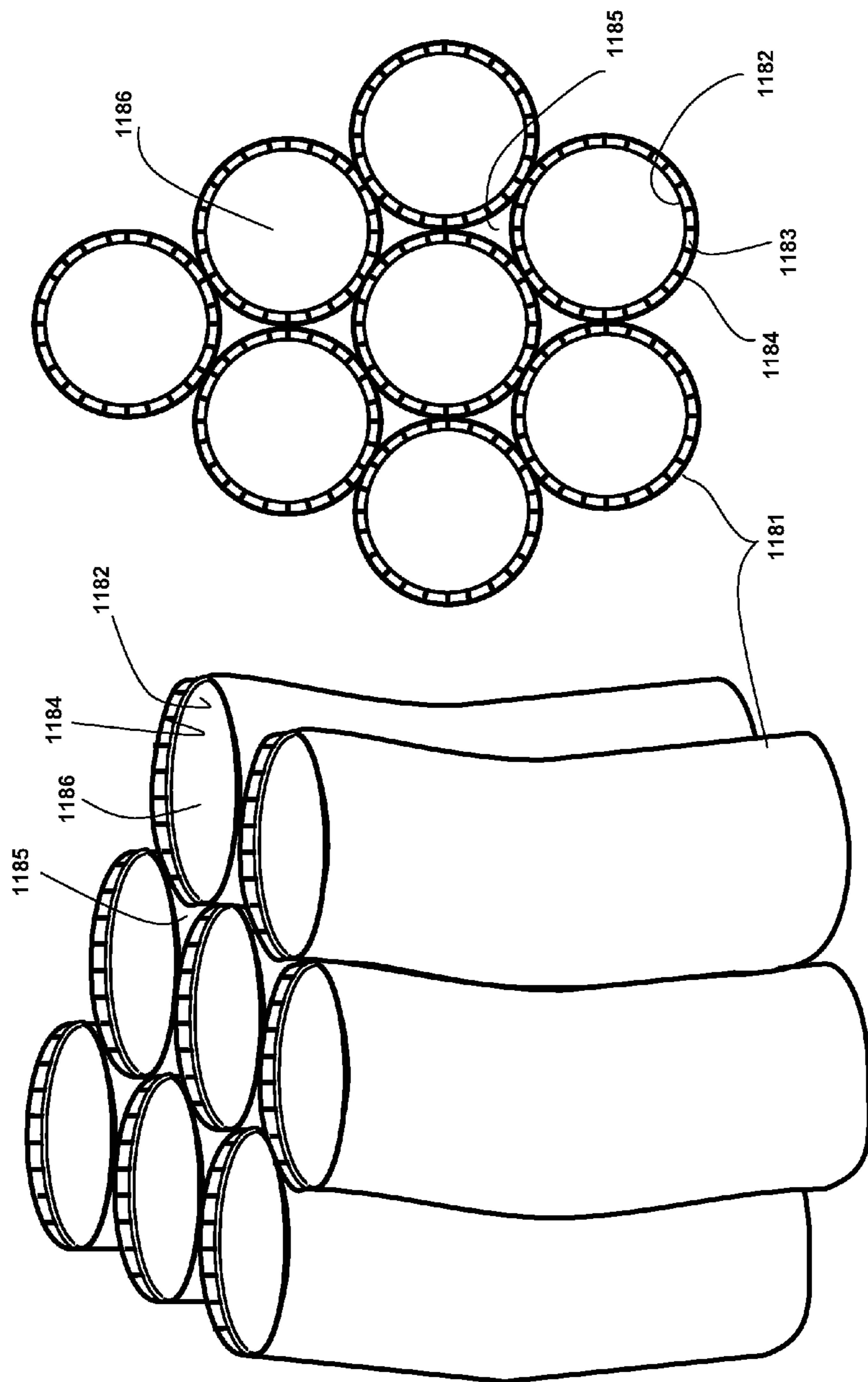

FIG. 11J

FIG. 11I

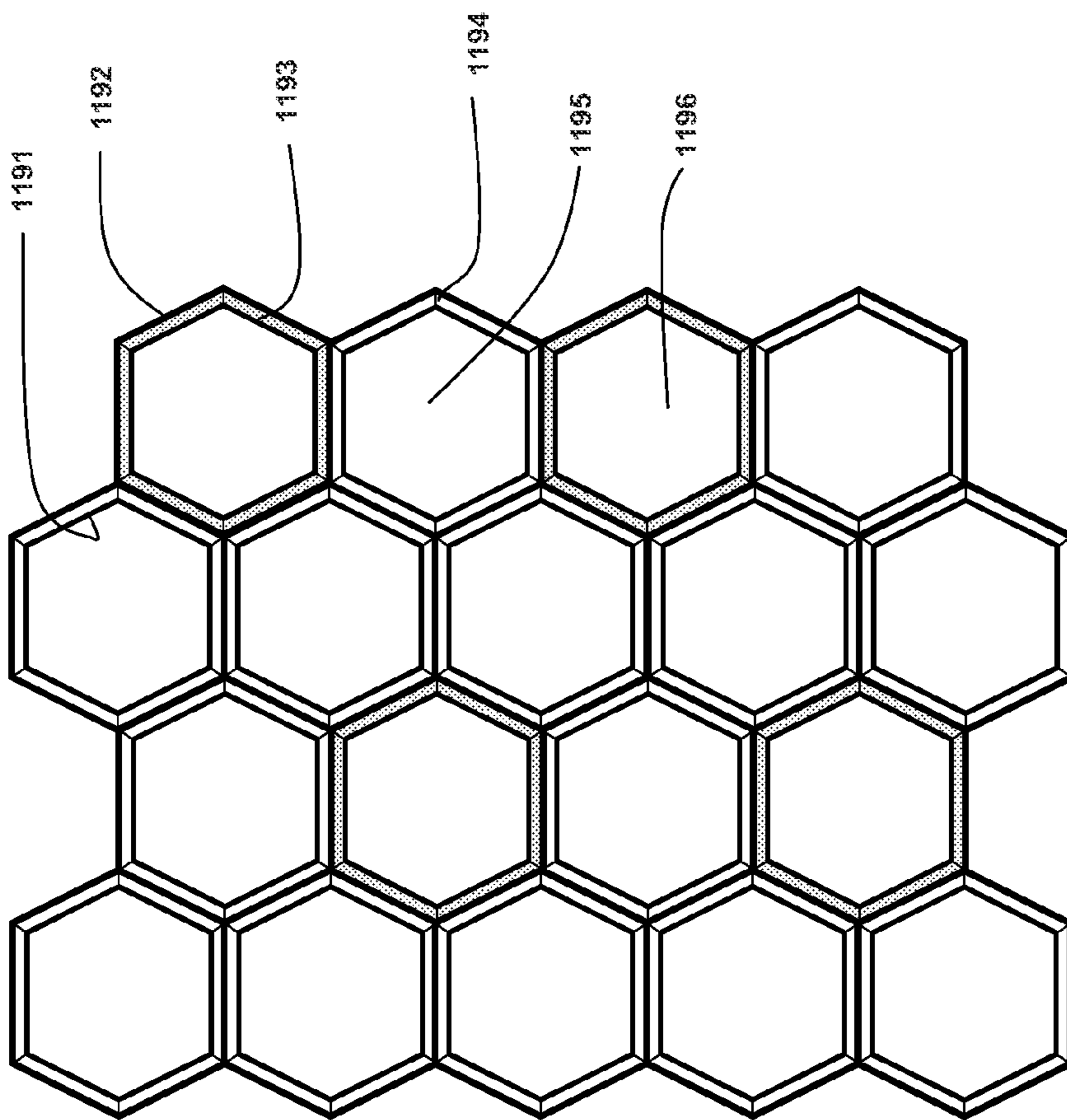

FIG. 11L

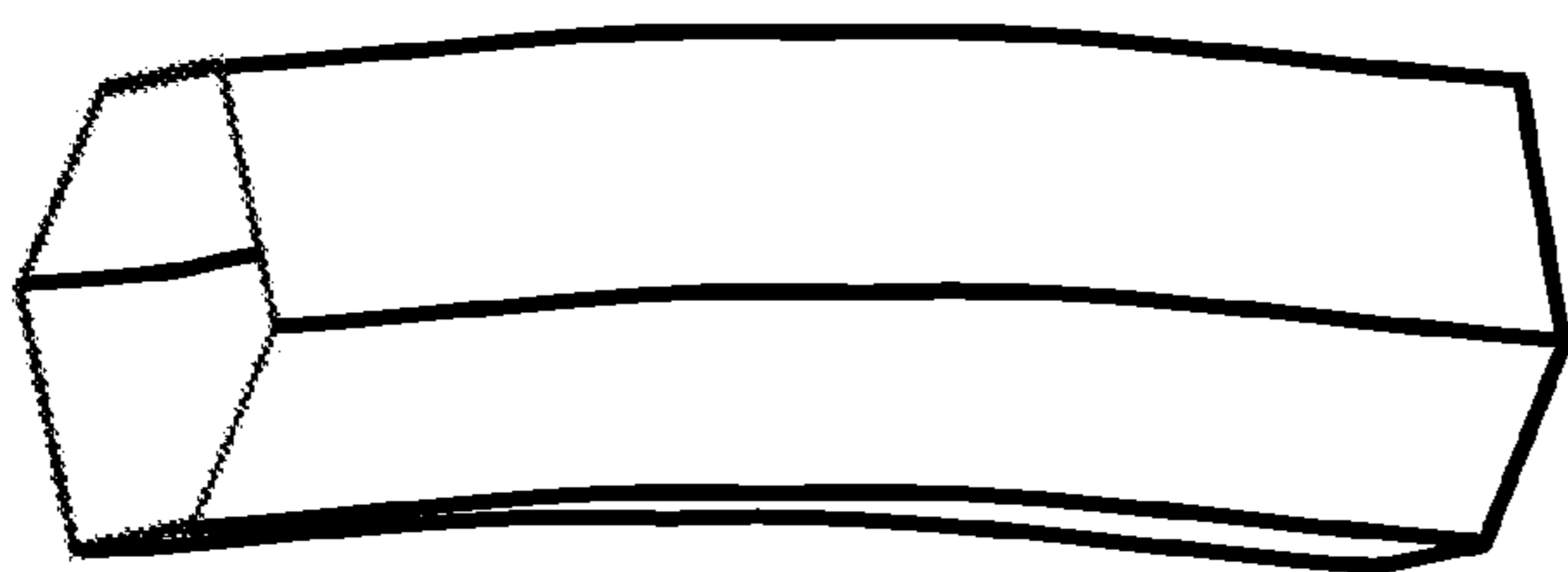

FIG. 11K

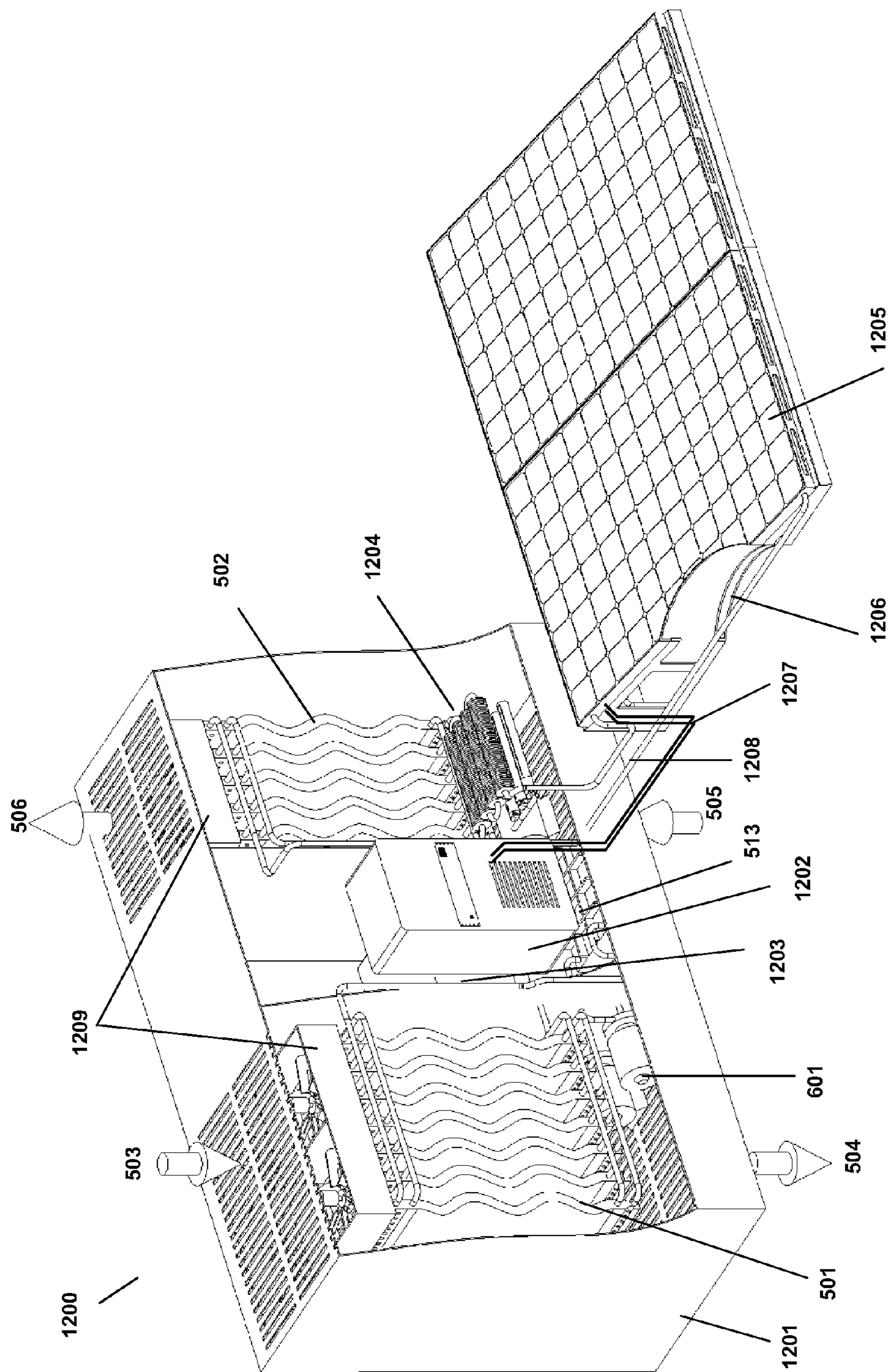

FIG. 12

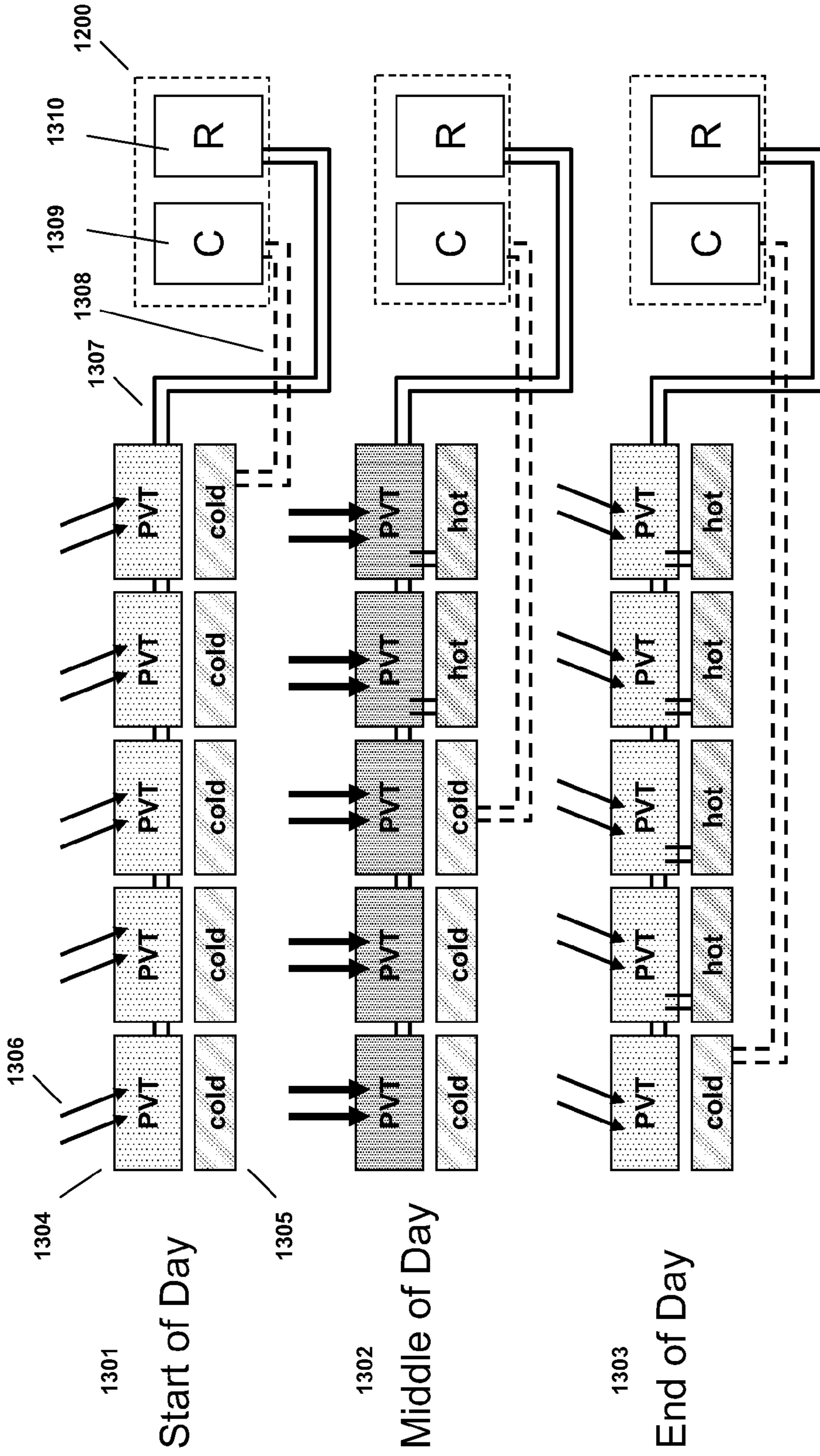

FIG. 13A



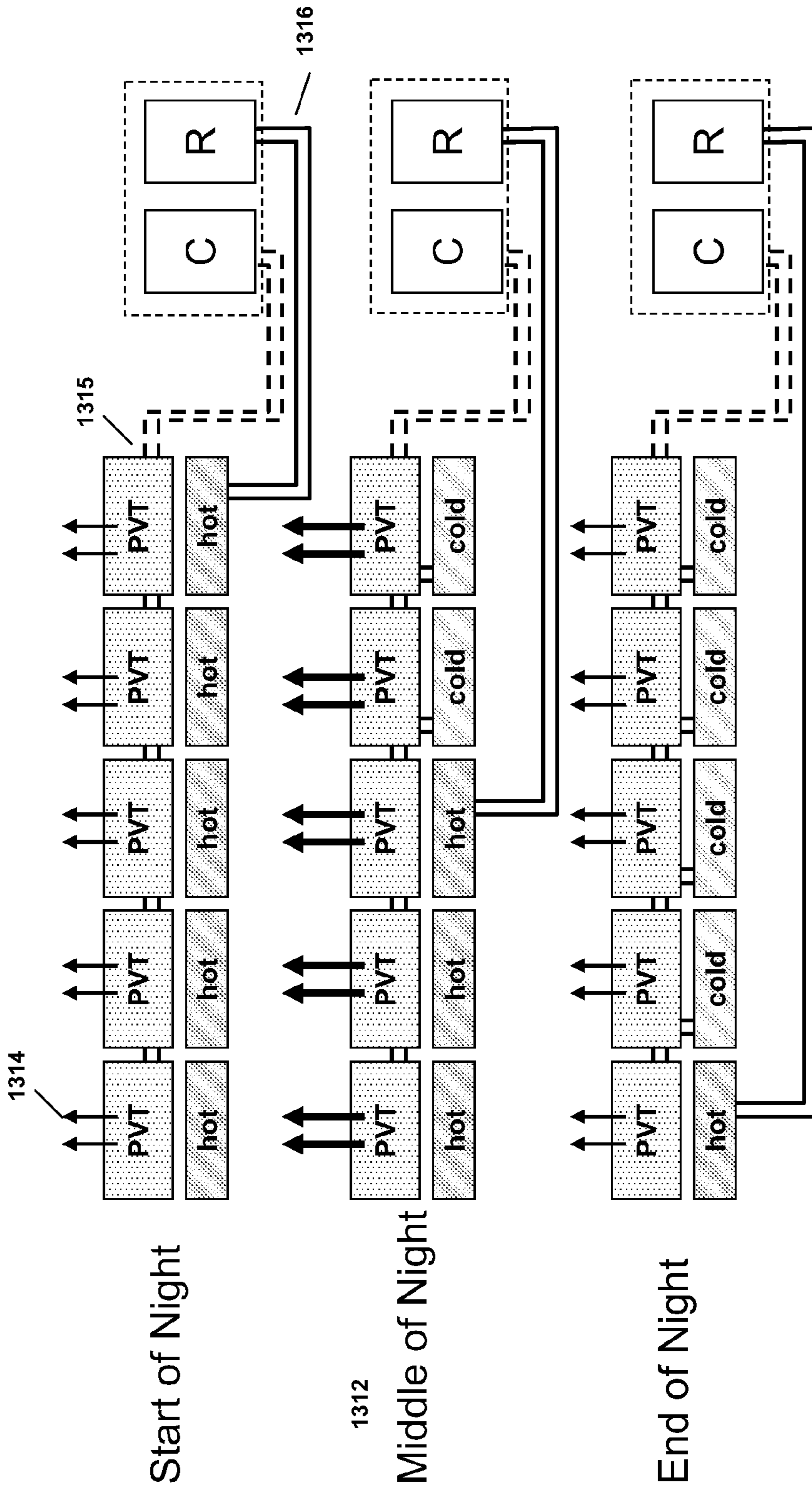

FIG. 13B

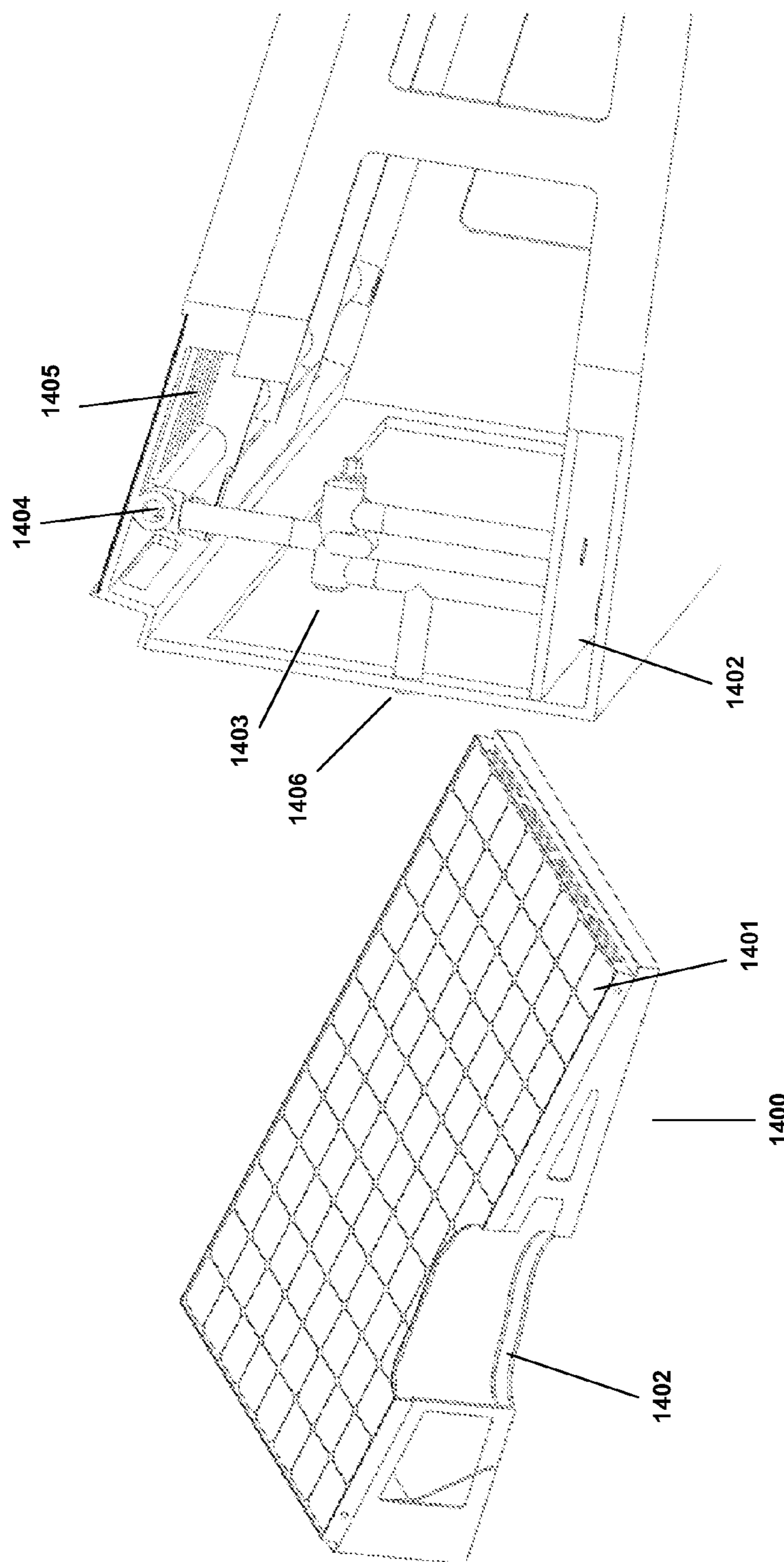

FIG. 14B

FIG. 14A

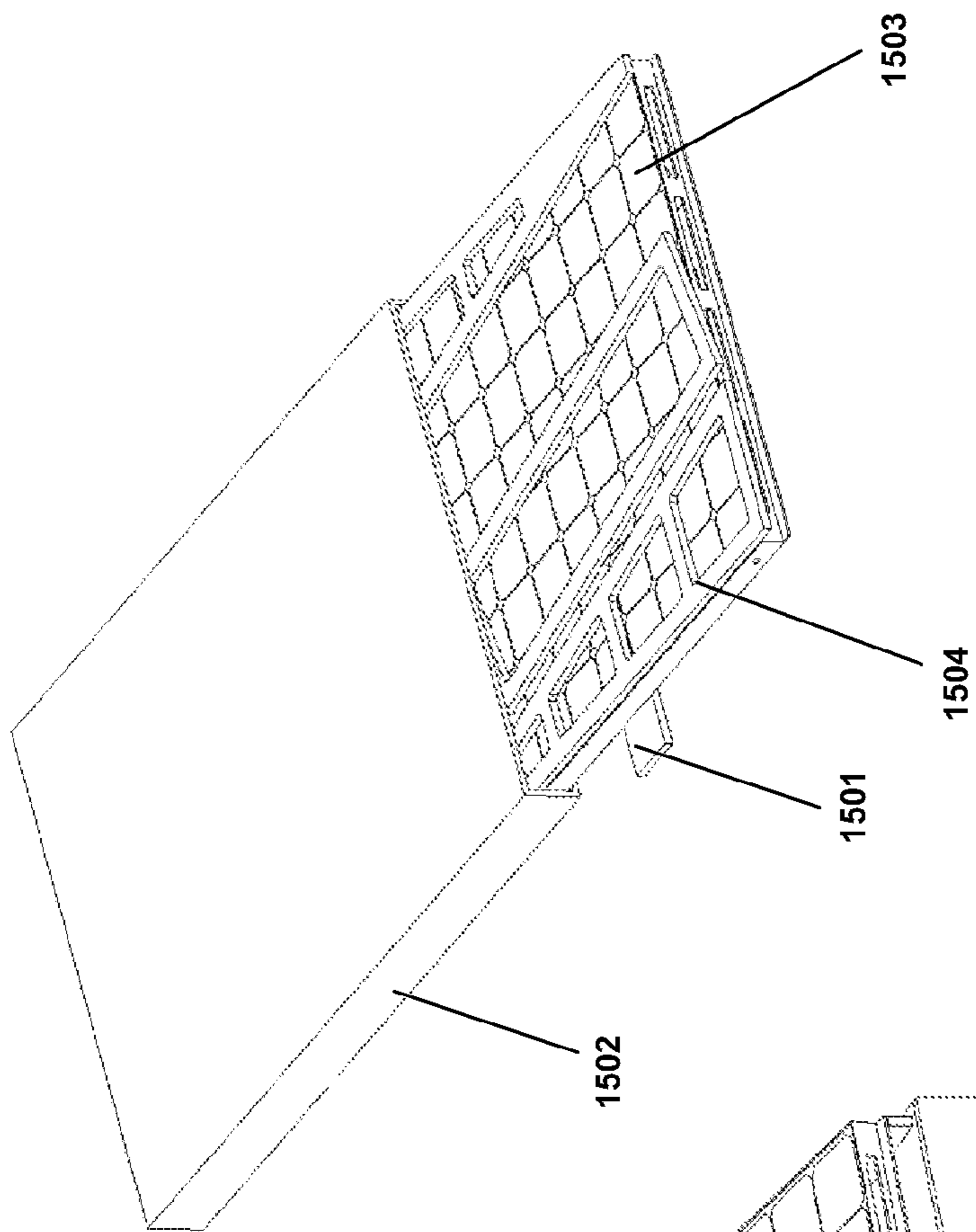

FIG. 15B

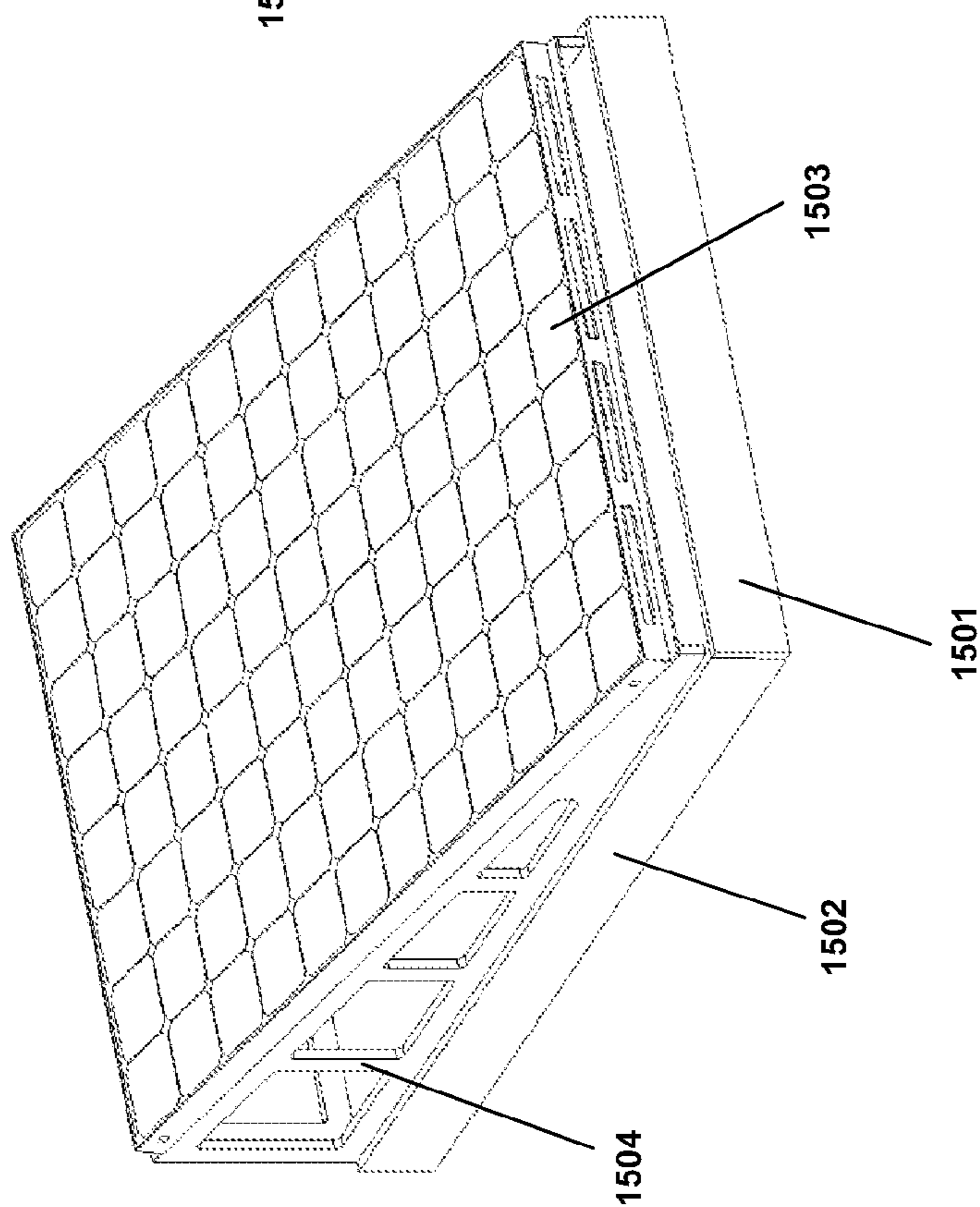

FIG. 15A

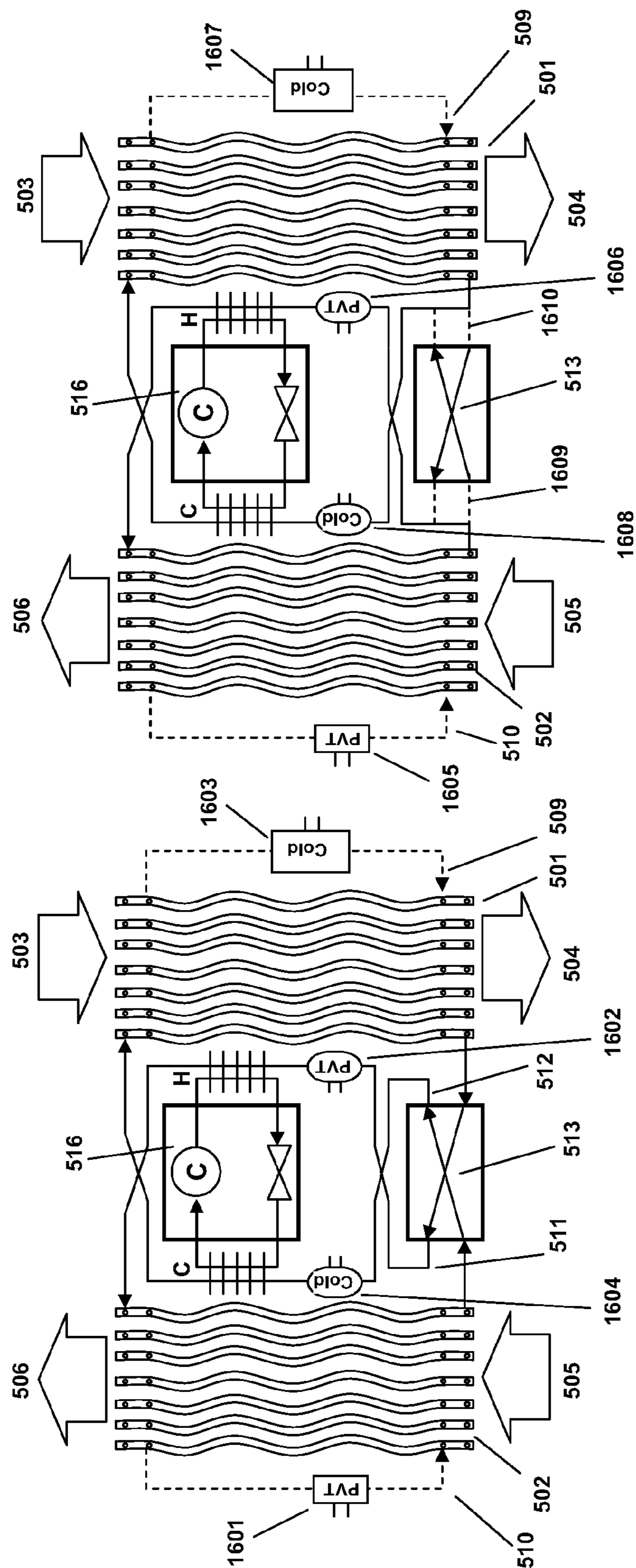

FIG. 16B

FIG. 16A

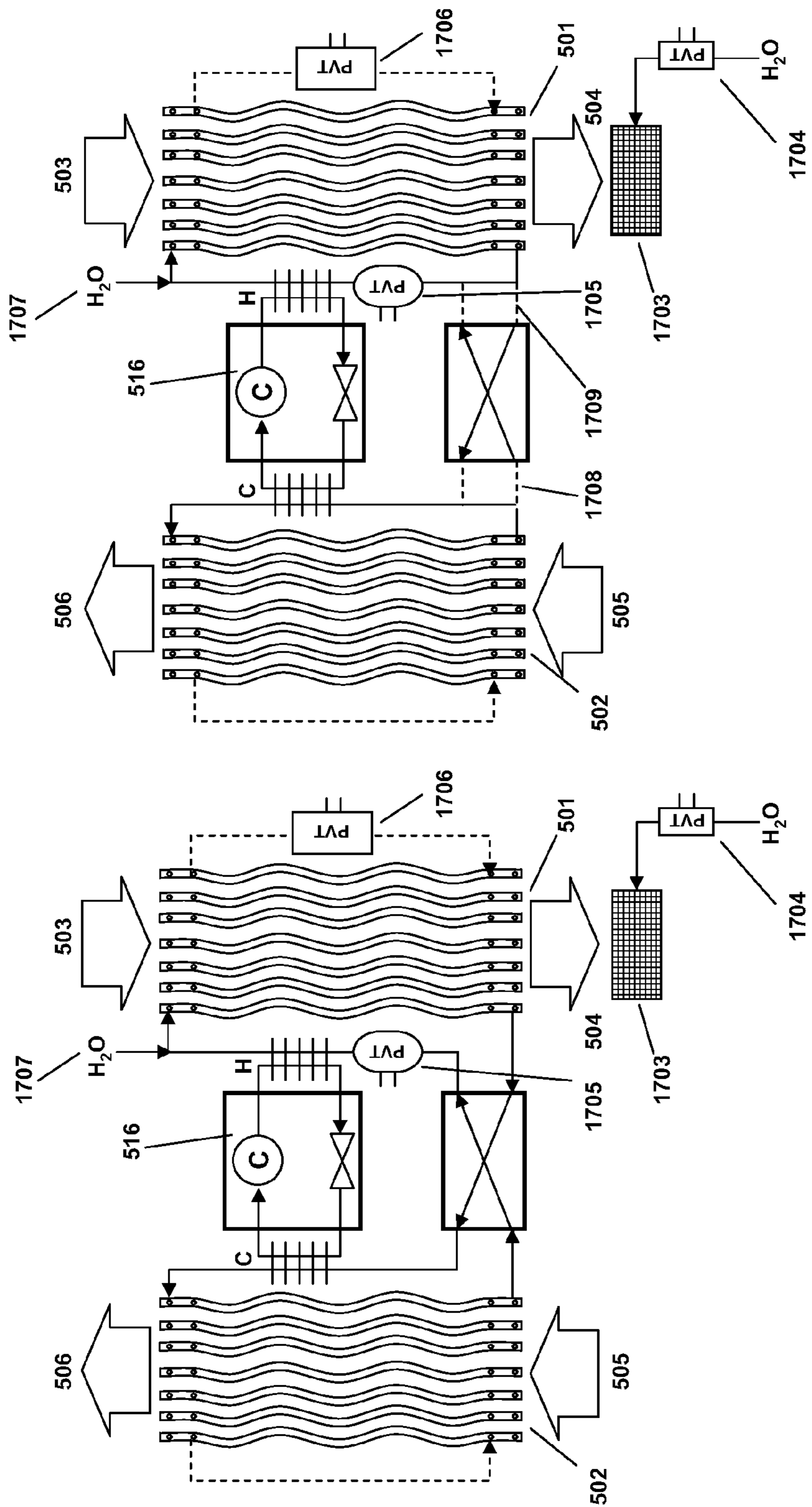

FIG. 17B

FIG. 17A

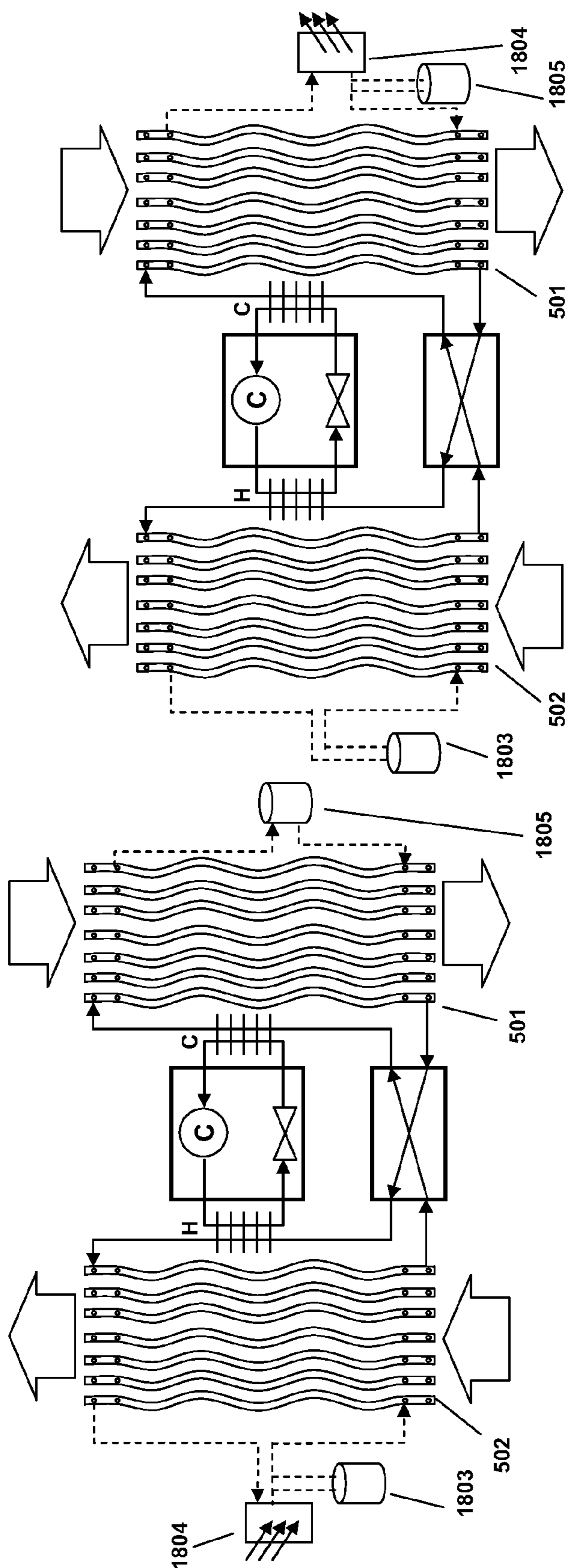

FIG. 18B

FIG. 18A

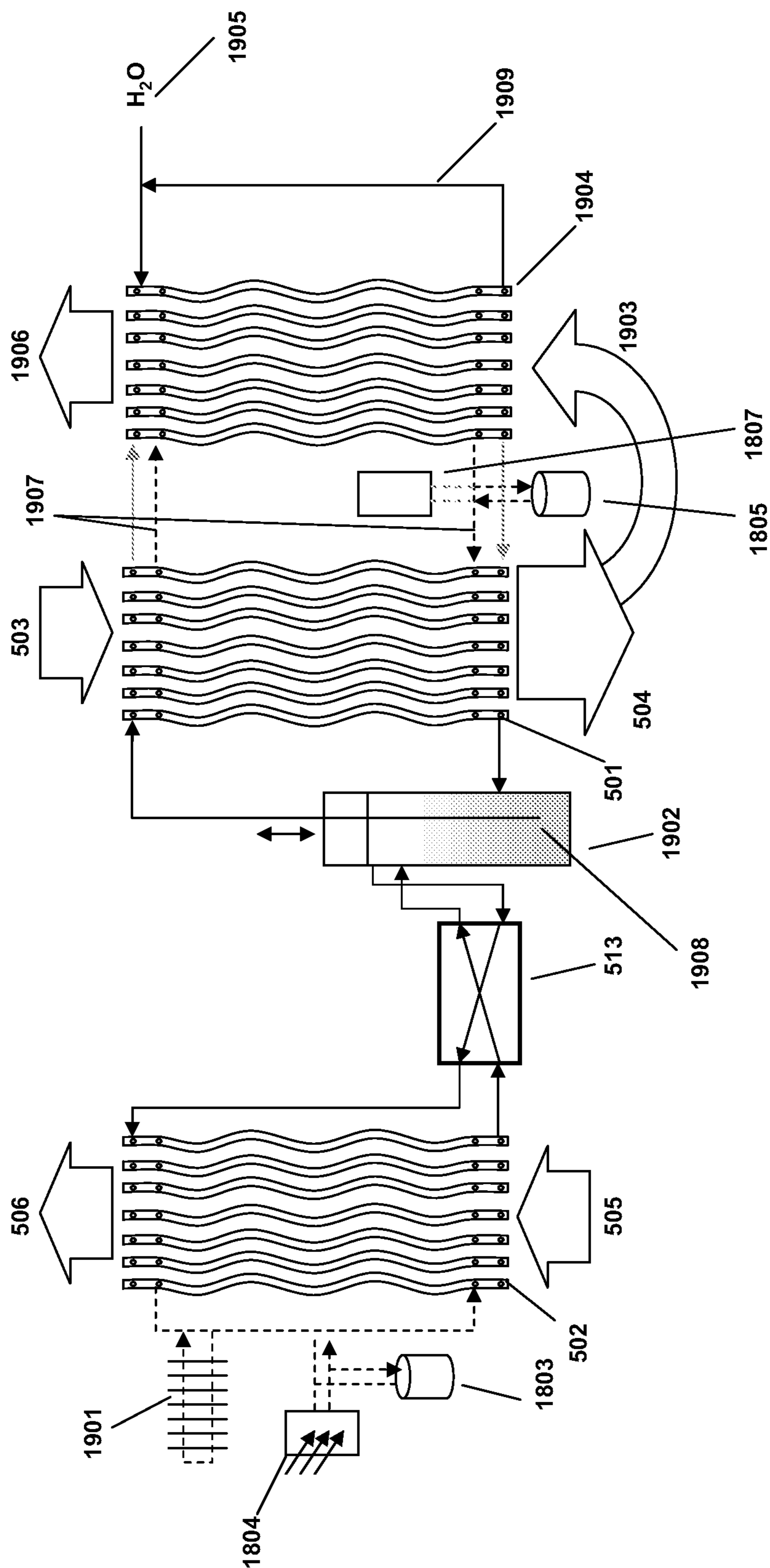

FIG. 19A

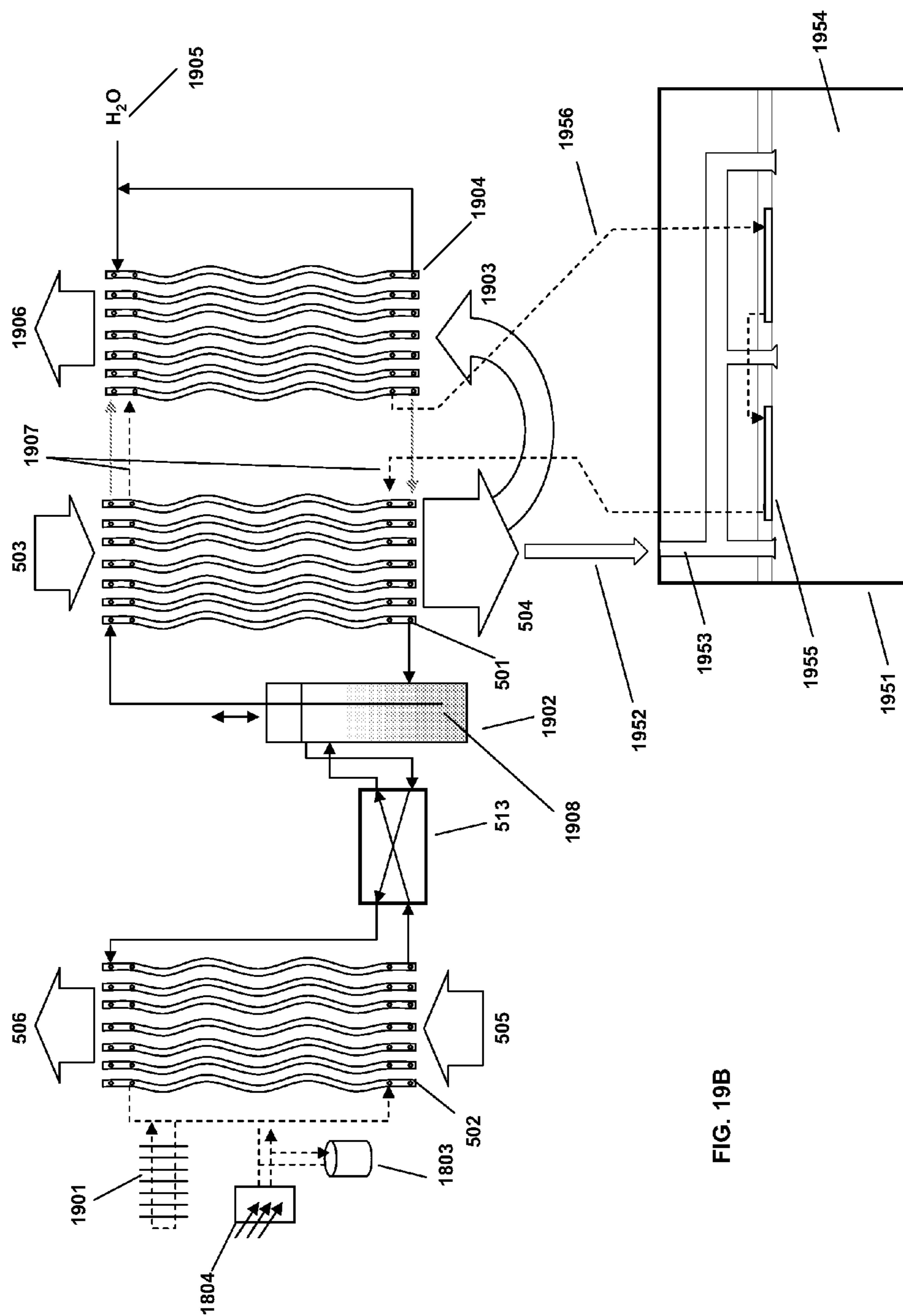

FIG. 19B



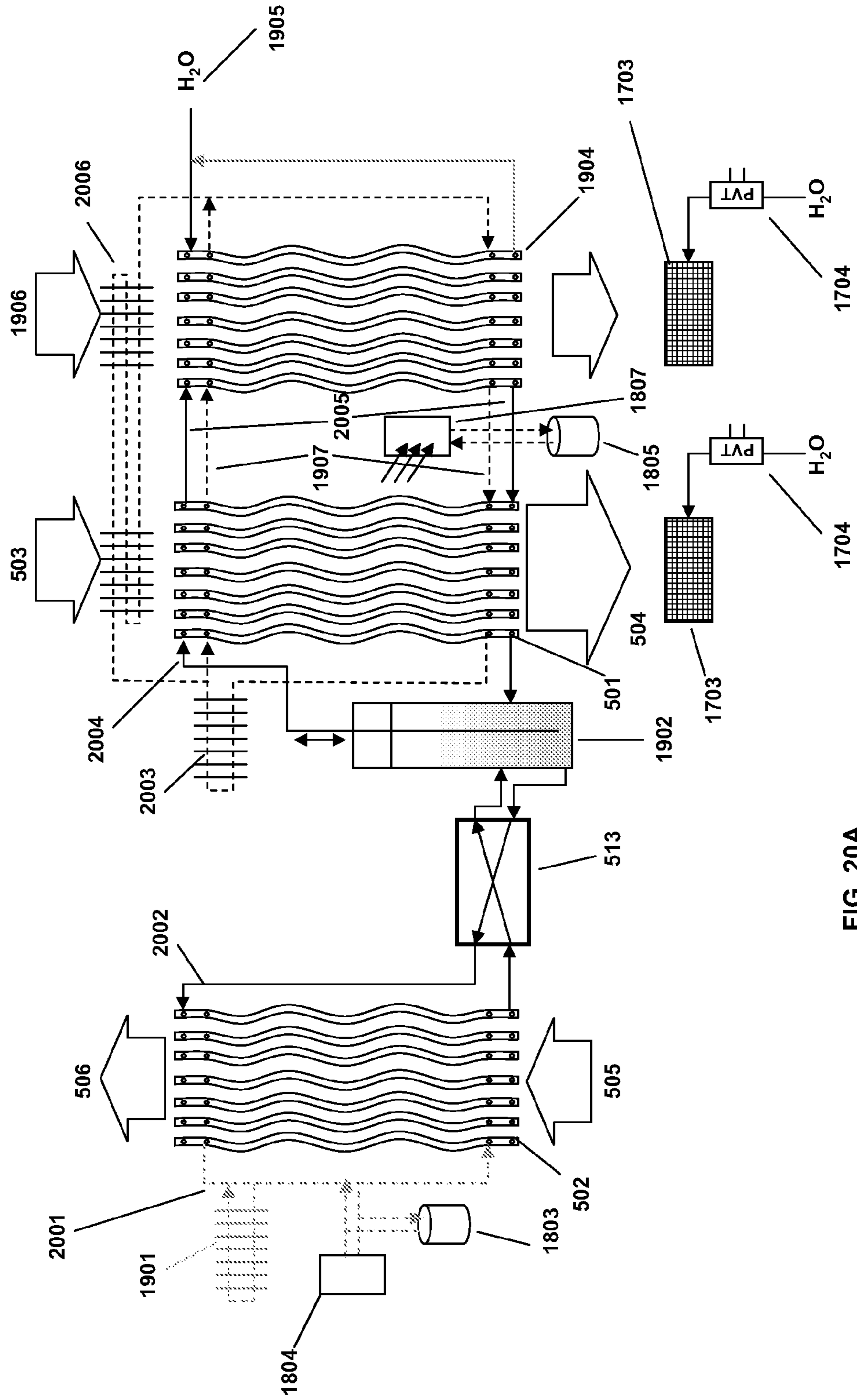

FIG. 20A

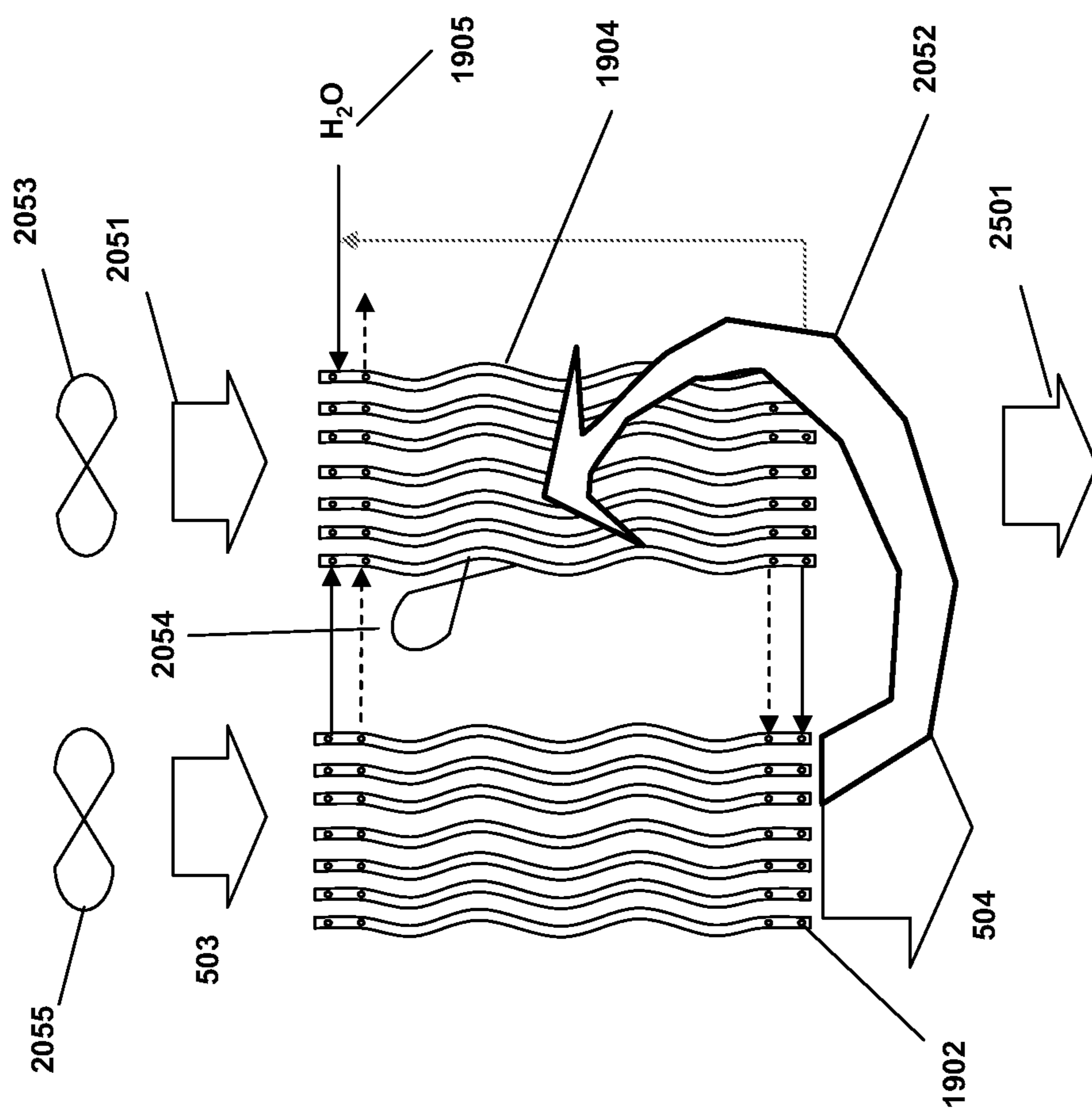

FIG. 20B

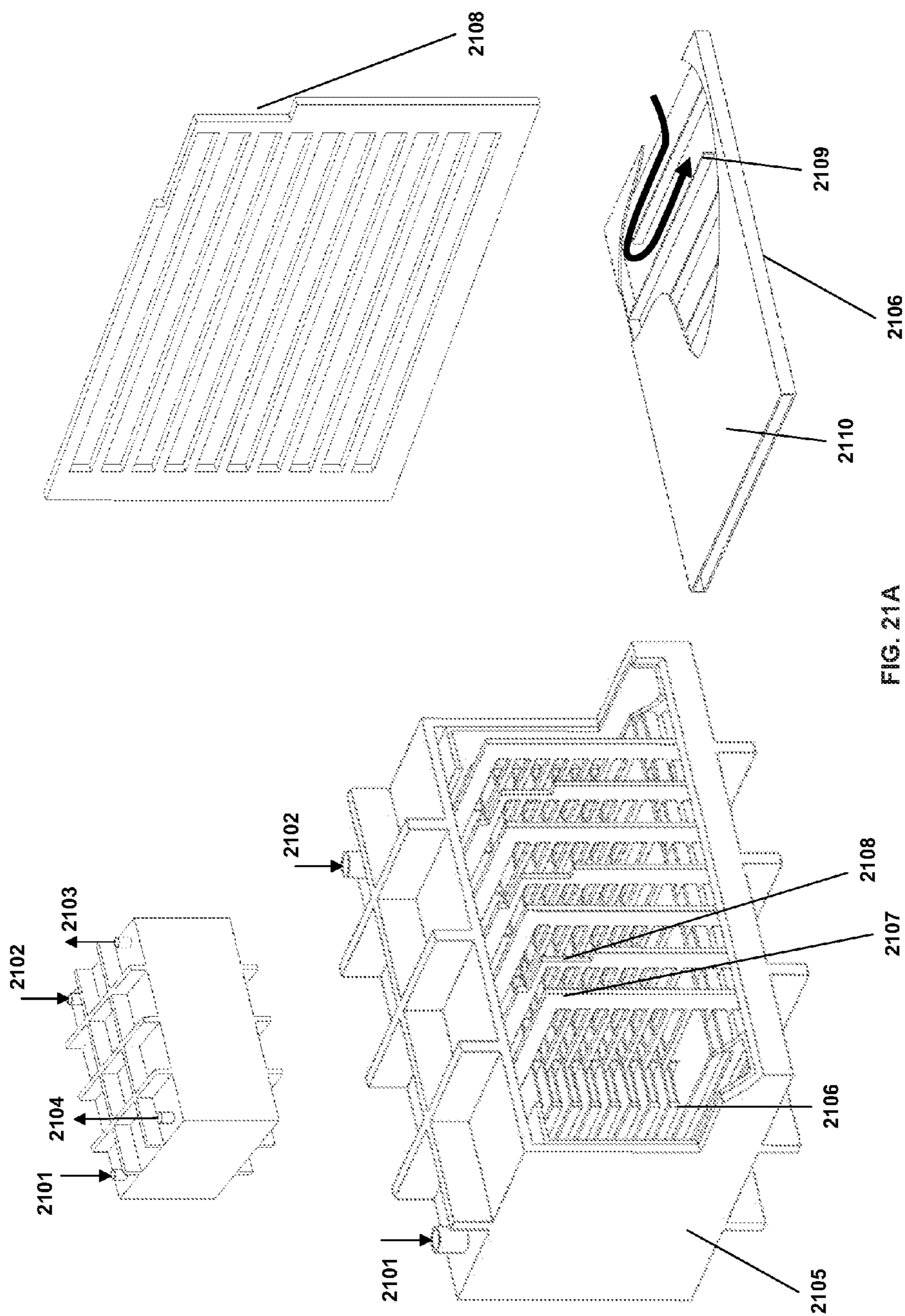
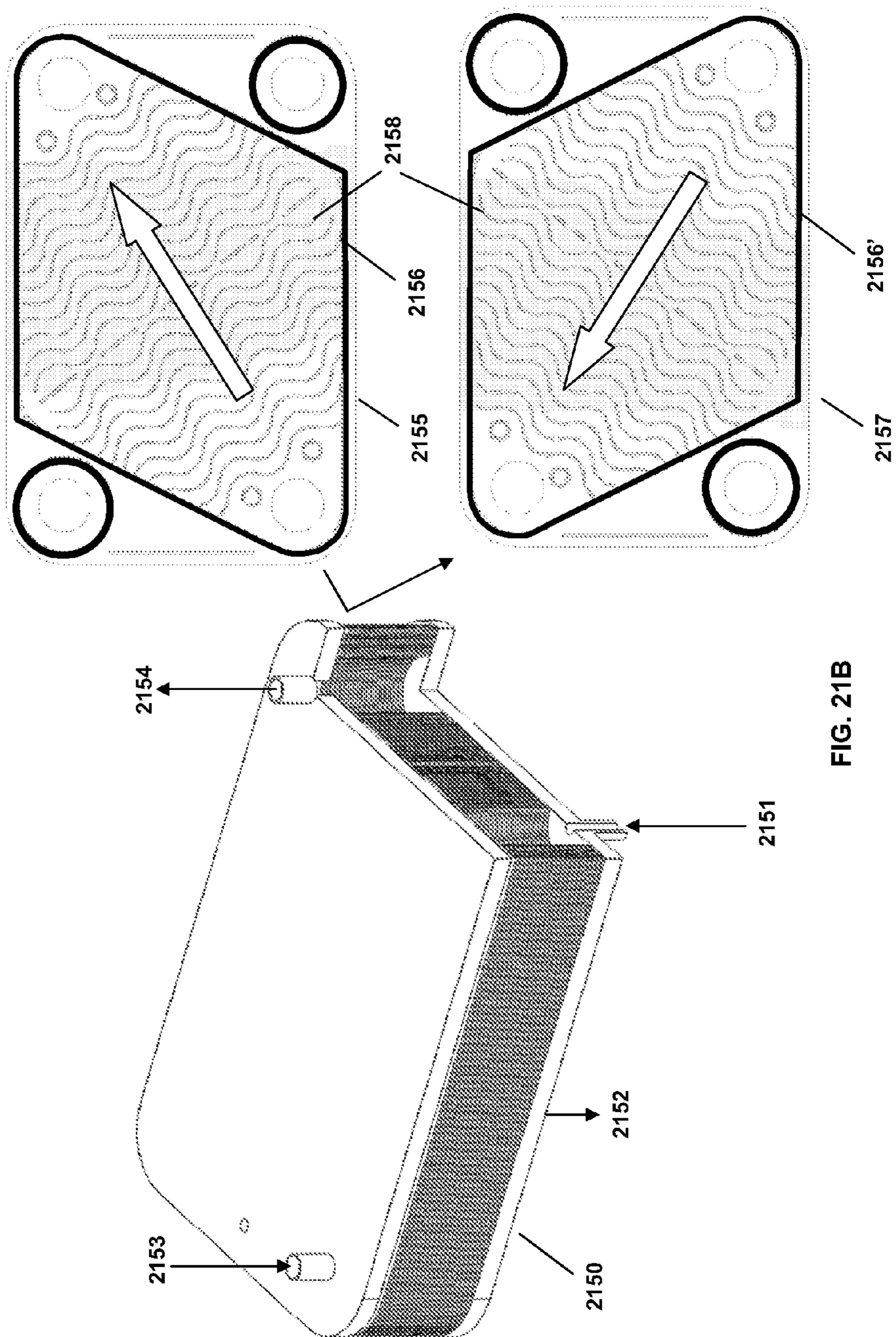

FIG. 21A



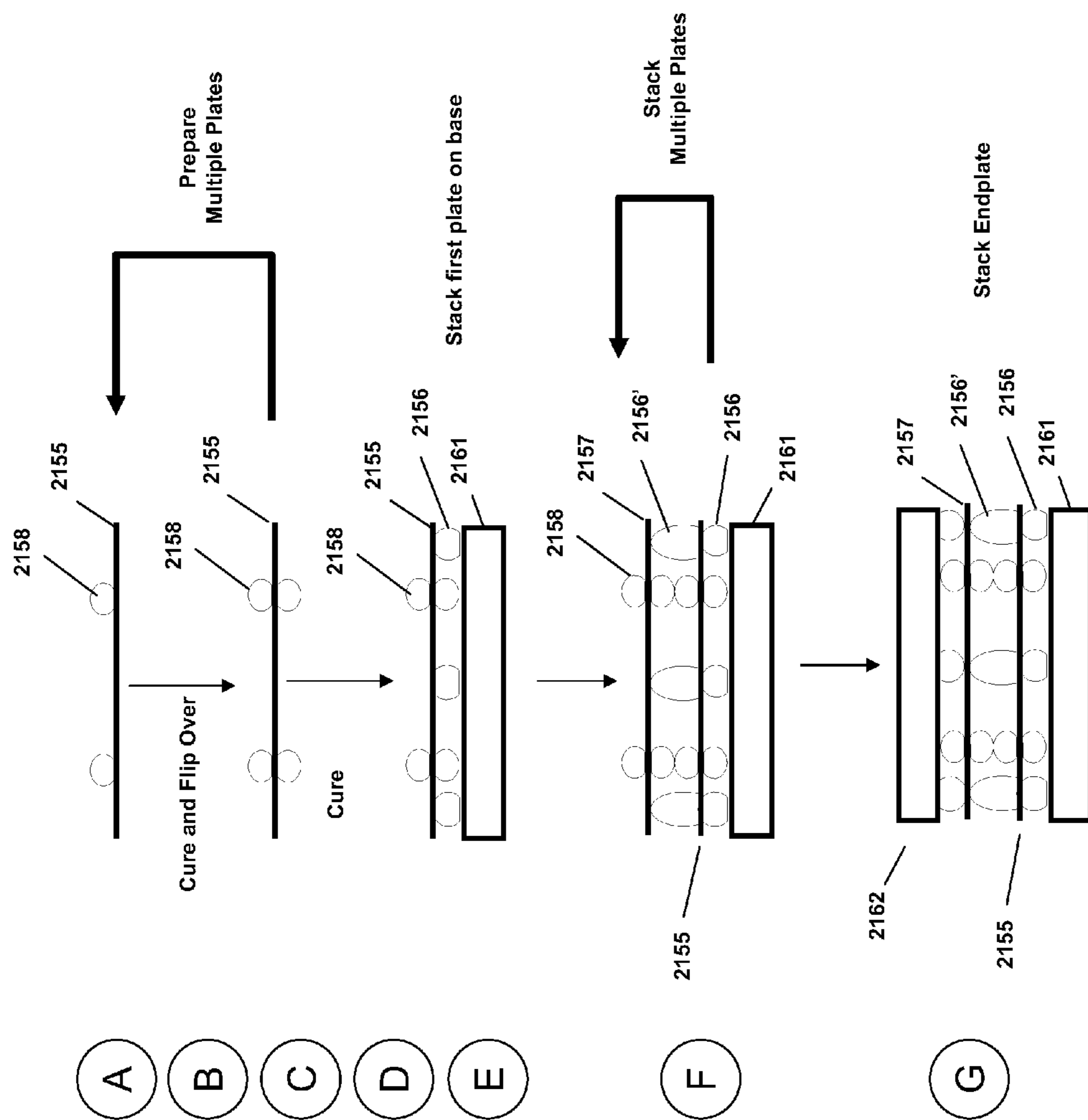

FIG. 21C

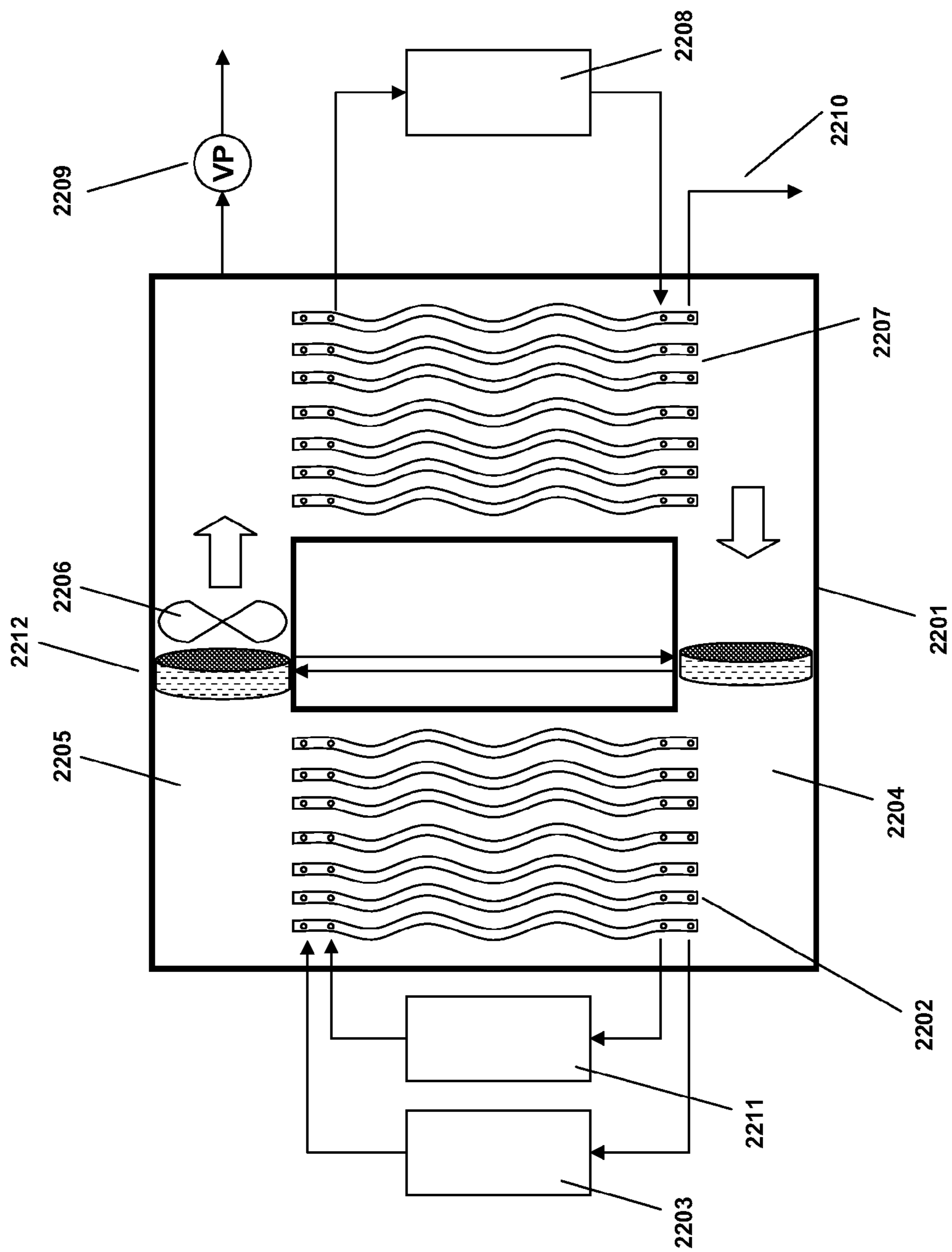

FIG. 22

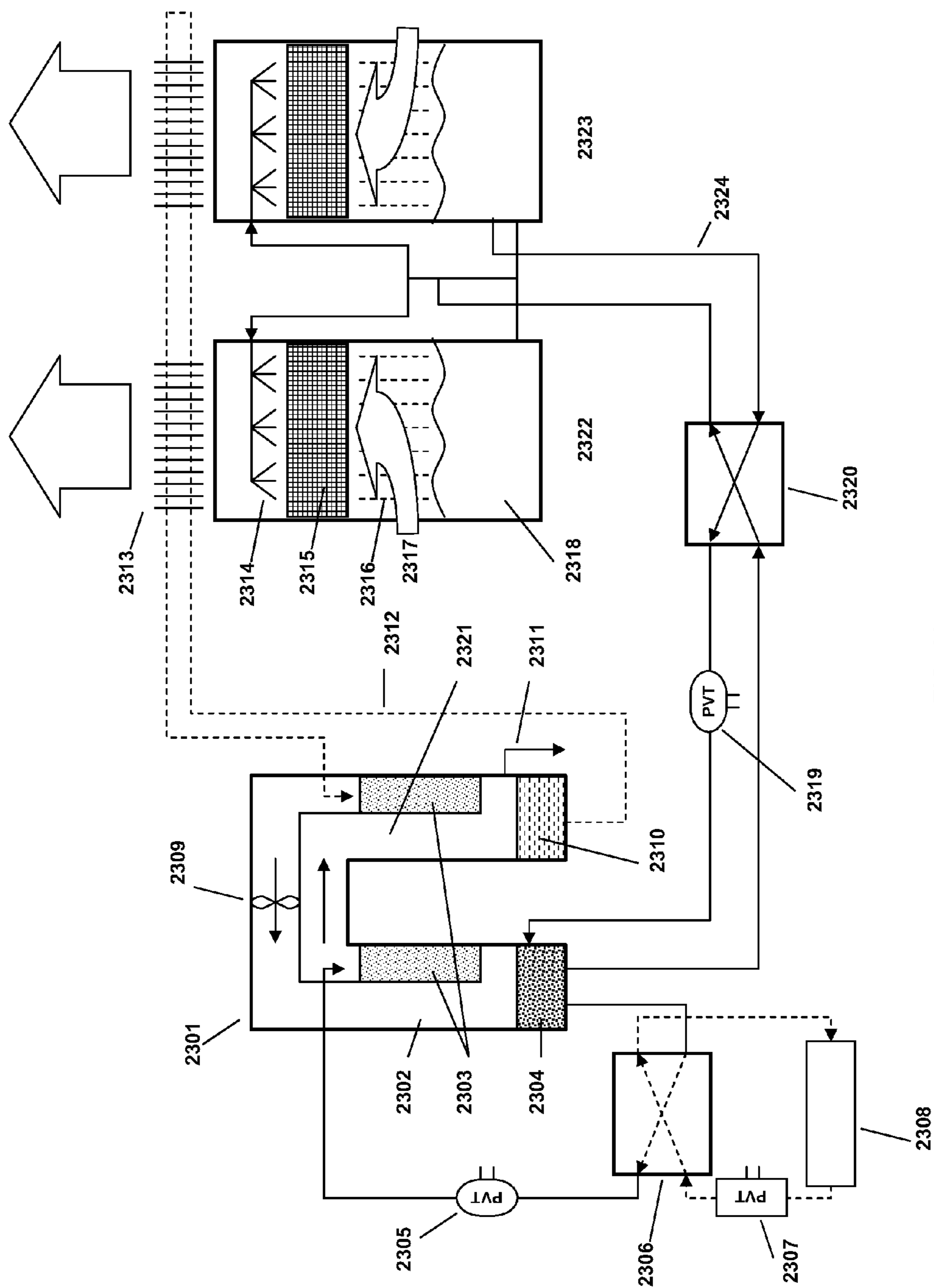

FIG. 23

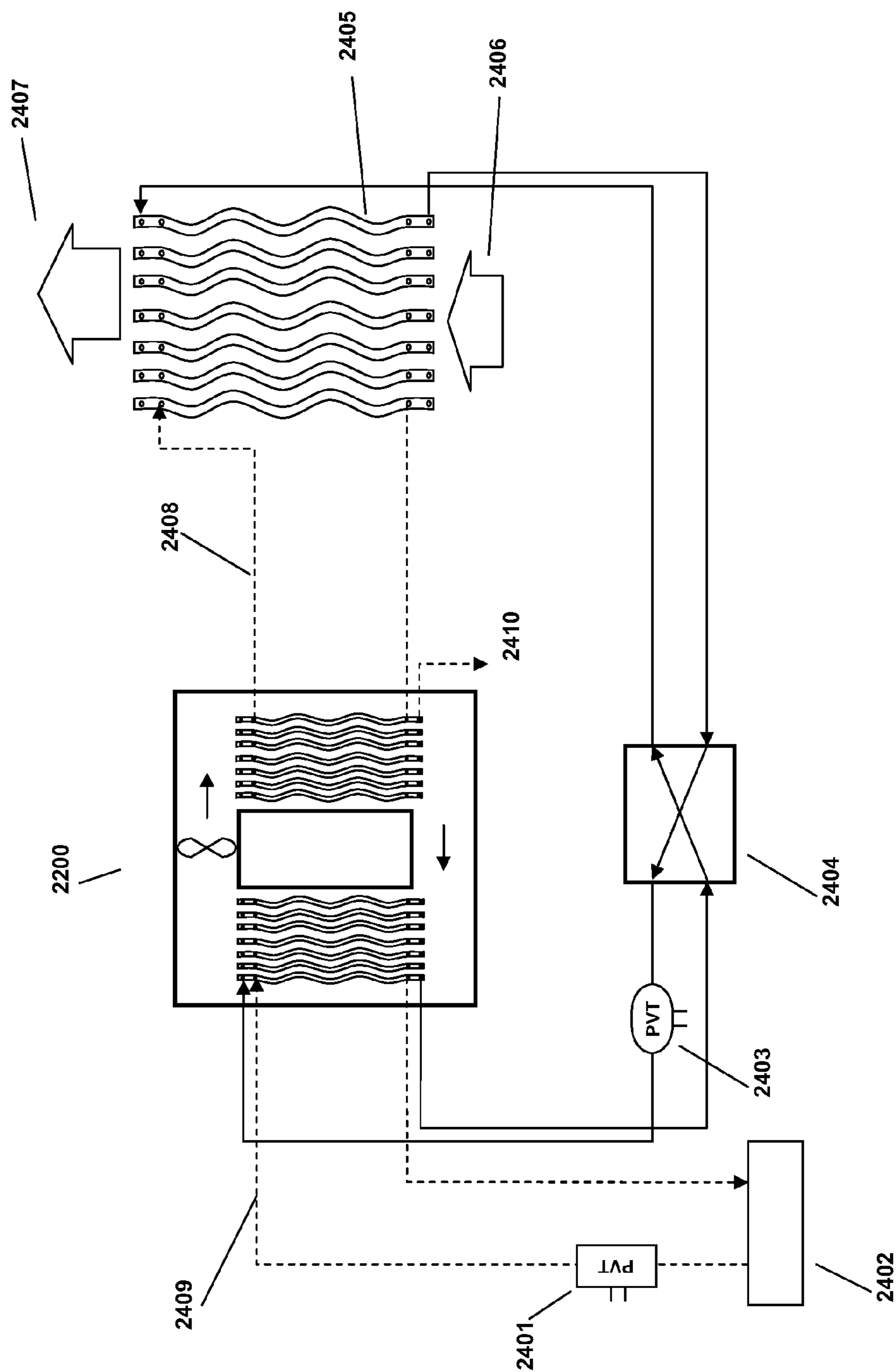

FIG. 24A



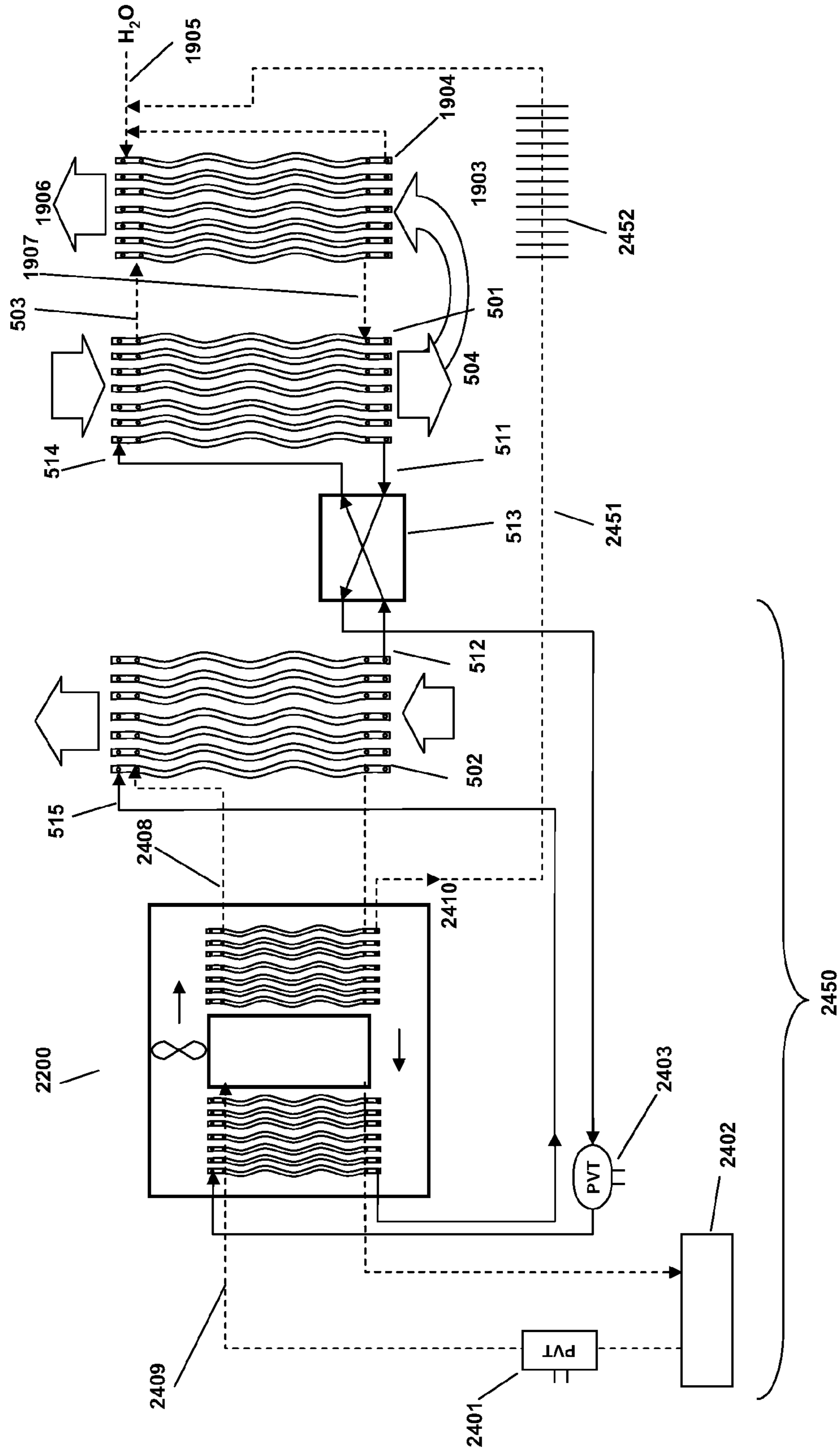

FIG. 24B

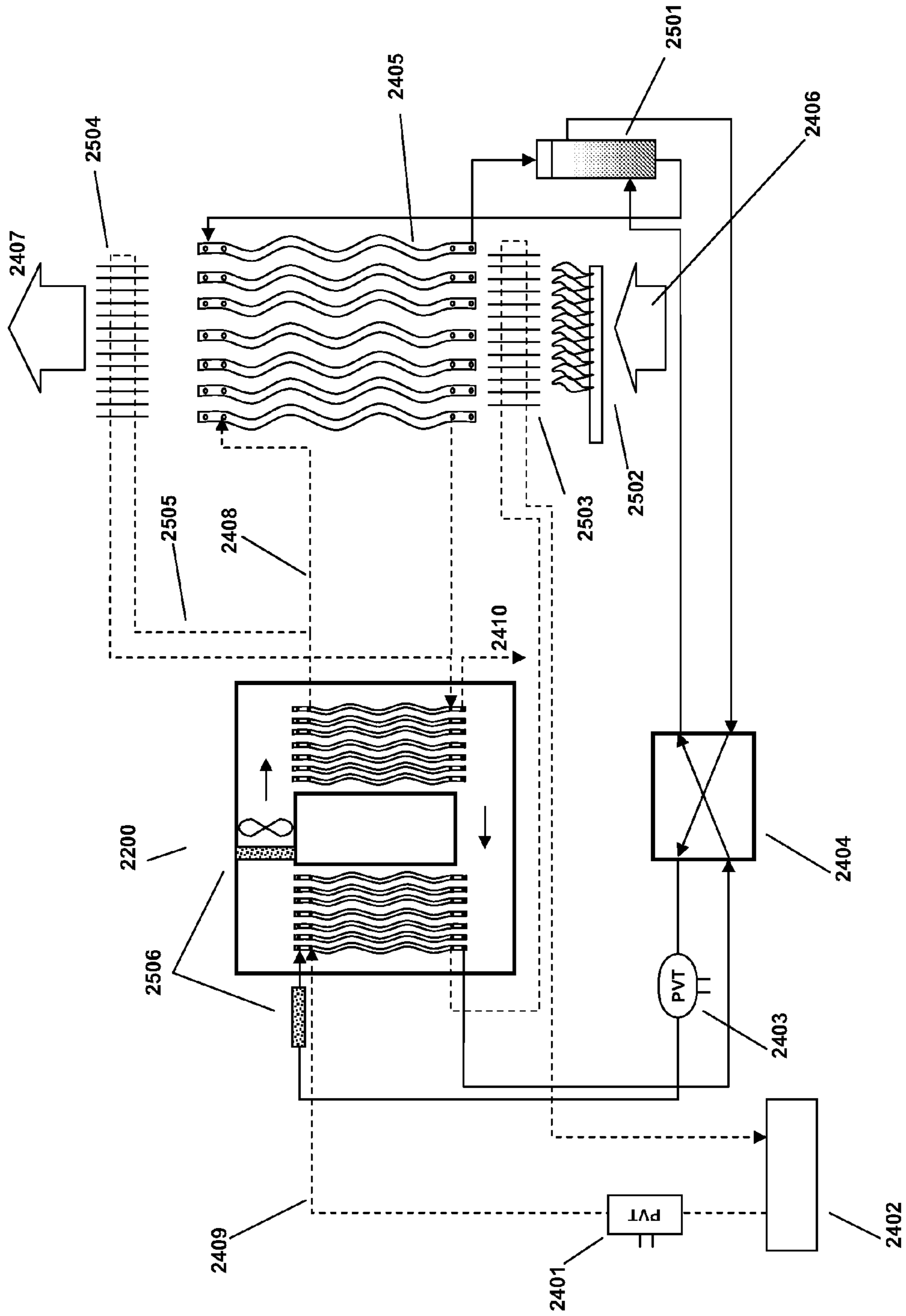

FIG. 25

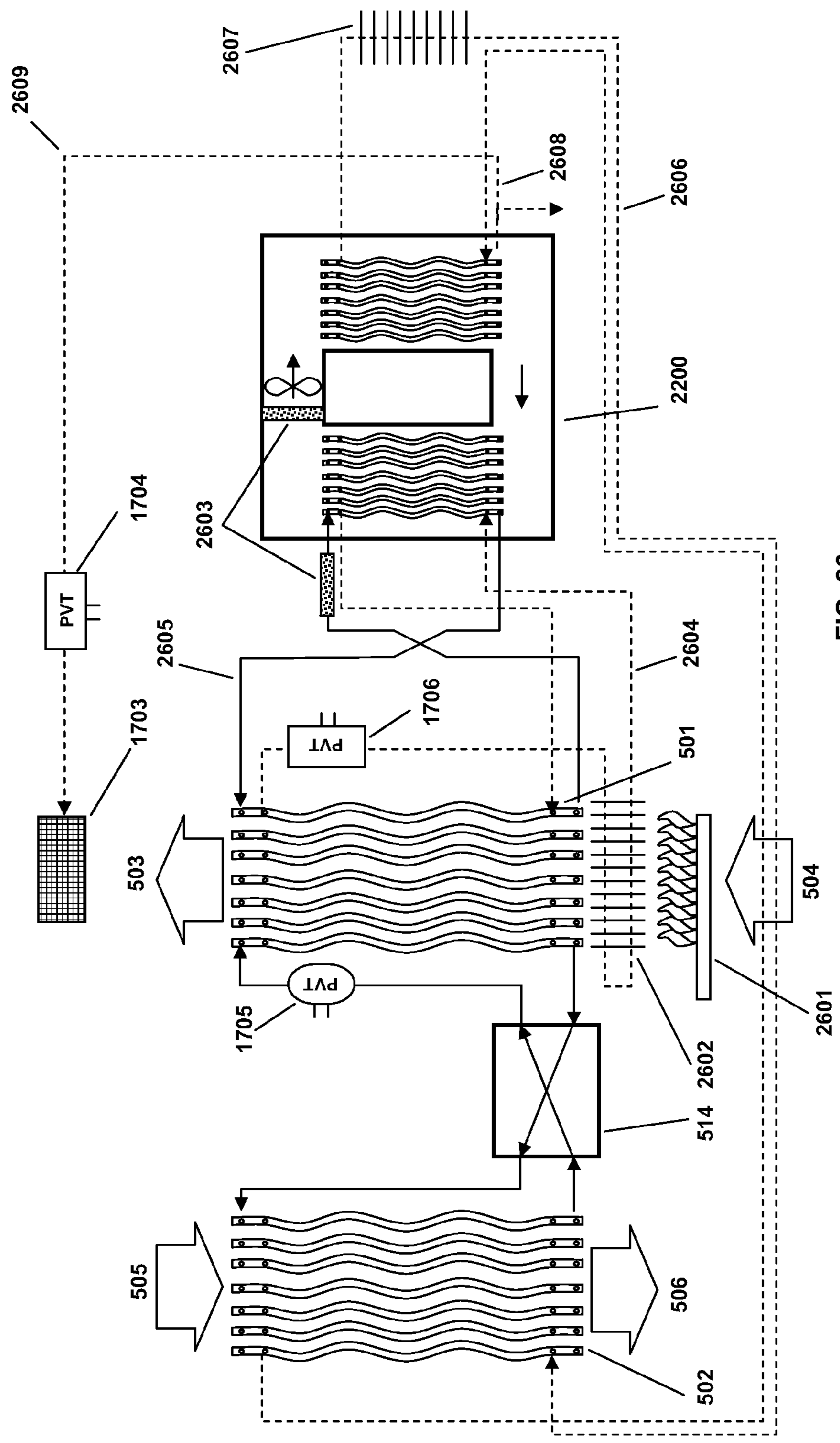

FIG. 26

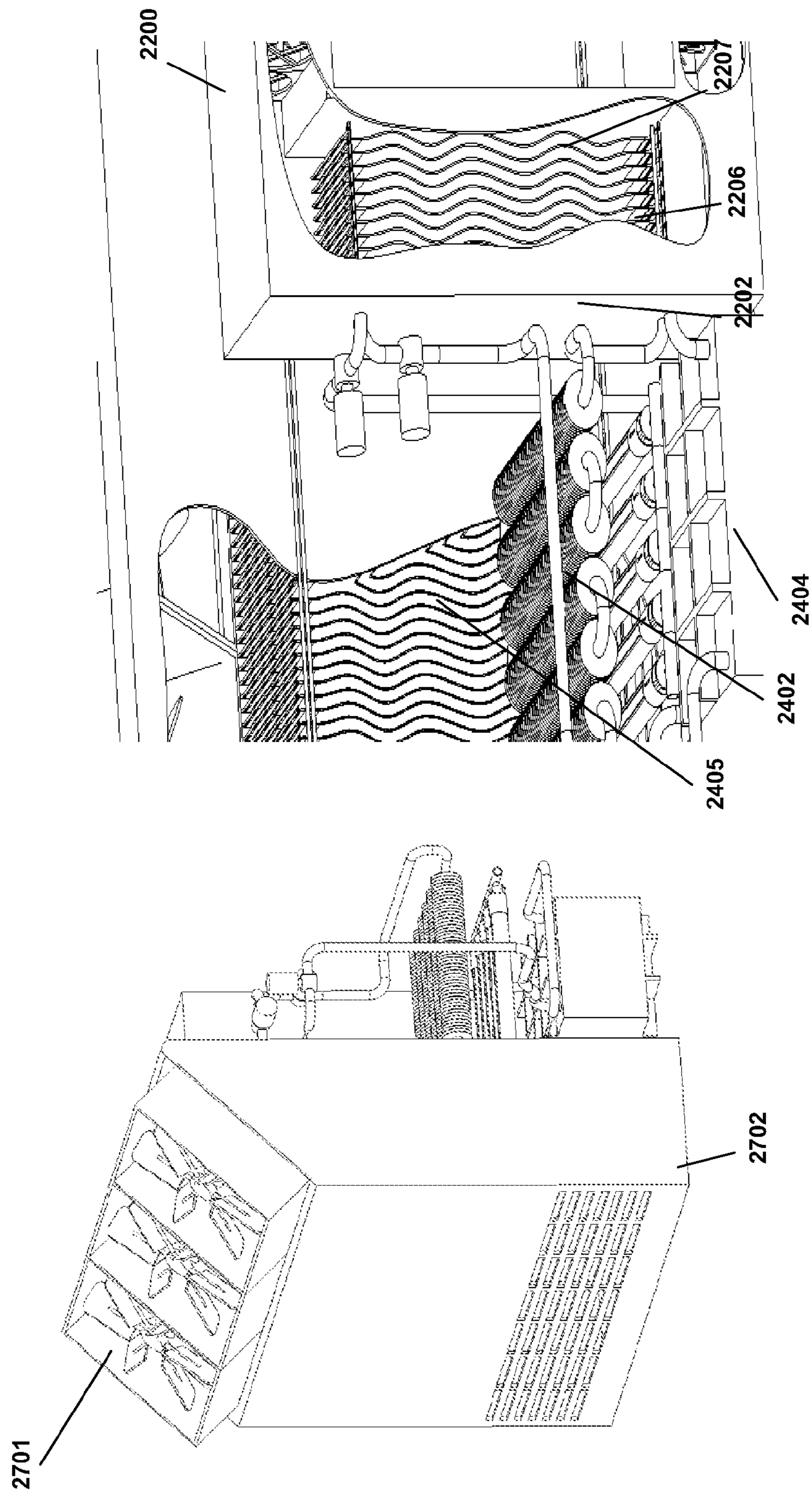

FIG. 27B

FIG. 27A

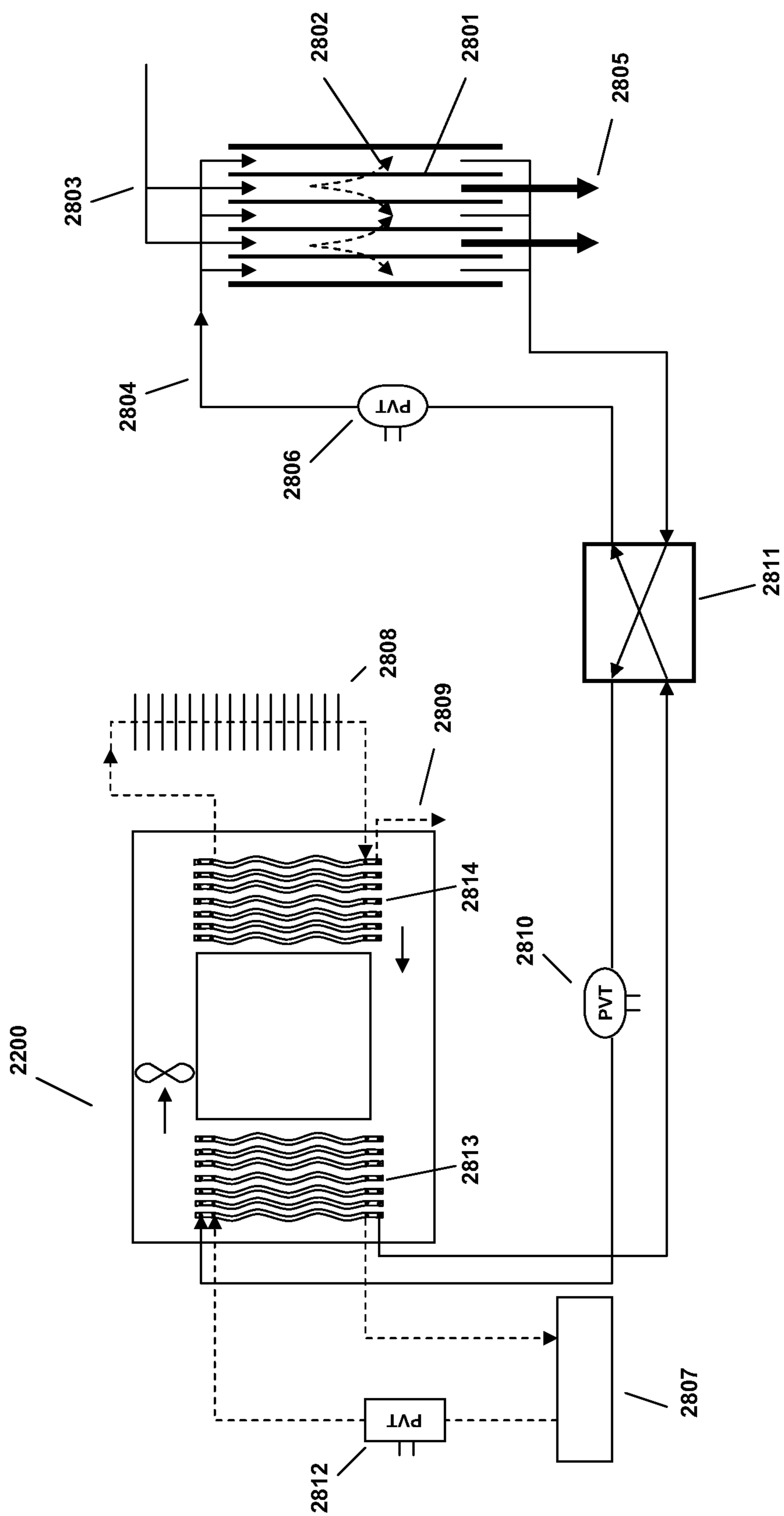

FIG. 28

## METHODS AND SYSTEMS FOR DESICCANT AIR CONDITIONING

### CROSS REFERENCE TO RELATED APPLICATIONS

**[0001]** This application is a division of U.S. patent application Ser. No. 13/115,789, filed on May 25, 2011, entitled METHODS AND SYSTEMS FOR DESICCANT AIR CONDITIONING, which claims priority from U.S. Provisional Patent Application Ser. No. 61/348,076, filed on May 25, 2010, entitled SOLAR AIR-CONDITIONING AND HEATING SYSTEMS and U.S. Provisional Patent Application Ser. No. 61/430,692, filed on Jan. 7, 2011, entitled METHODS AND SYSTEMS FOR DESICCANT AIR CONDITIONING, all three of which are hereby incorporated by reference.

### BACKGROUND

**[0002]** The present application relates generally to air conditioning, capturing combustion contaminants, desalination, and other processes using liquid desiccants.

**[0003]** The term “air conditioning” generally refers to the treatment of air going into a building space, including to the heating, cooling, humidity adjustment, or purification of air that enters or leaves the space. It is well known that air conditioning is an enormous source of energy use and that summer cooling in particular can lead to electricity grid problems. Air conditioning is often the largest operating cost in a building.

**[0004]** Current air conditioning systems for cooling are generally based on the compression of a gas such as Freon and the expansion of the compressed gas through a valve assembly. However, in order to reach the required humidity levels of the entering air into a building, the air generally needs to be overcooled in order to condense water vapor into liquid water. This dehumidification (latent cooling) generally uses more energy in an air conditioning system than the physical lowering of the air temperature (sensible cooling). Oftentimes re-heaters are employed within an air conditioner requiring even larger amounts of energy.

**[0005]** Air conditioning for heating air is typically done by combustion of natural gas or some other fuel. The combustion often heats a heat transfer fluid that is then directed to a fan coil unit where the entering air is heated. In many buildings, such sensible only heating results in humidity levels that are too low for comfort. Oftentimes humidifiers are integrated with the heating system. Such humidification however results in the cooling of the air, which means that additional heating will have to be applied to counteract the cooling effect of the humidifier.

**[0006]** Solid desiccant systems have been used for many years primarily for summer cooling. However, the heating effect that occurs when air is dehumidified in an adiabatic fashion (no heat is added or removed) requires large amounts of sensible cooling post-dehumidification and as a result limits the energy savings that can be obtained.

**[0007]** Absorption chillers such as units manufactured by Yazaki Energy Systems typically utilize a low pressure vacuum vessel in which a desiccant material is contained (in Yazaki’s case LiBr<sub>2</sub> and water, but systems using Silica gel have also been developed). However, the use of low pressure vacuum systems significantly increases the cost and complexity of the equipment and increases the requirements for main-

tenance. Also, each transition (from air to a heat transfer fluid to the desiccant) utilizes heat exchangers, fans, and pumps and thus results in higher costs. And importantly, such transitions result in larger temperature requirements since each transition is not perfectly efficient. As a result, absorption chillers require higher temperatures to operate making them less suitable for integration with systems that employ waste heat or low grade heat.

**[0008]** More recently systems have been introduced that employ other methods for dehumidification of the air. Liquid desiccant systems such as the systems manufactured by DuCool and Agam use a strong desiccant material such as a CaCl<sub>2</sub> and water or LiCl<sub>2</sub> and water solution to absorb water vapor in the air. The liquid desiccant is directly exposed to the air unlike the previously discussed absorption chillers that do not have air to desiccant direct contact. After the desiccant absorbs moisture from the air stream, it is heated to release the excess water. In winter, such desiccants can be used to recover heat and moisture from the leaving air and transfer it to the incoming air.

**[0009]** Liquid desiccant systems however have traditionally suffered from the risk of desiccant carry-over into the air stream resulting in sometimes severe corrosion problems in the building since the desiccants that are used are typically strongly corrosive to metals.

**[0010]** Furthermore, liquid desiccant systems are typically spraying a liquid desiccant on a filter media to increase the surface area of desiccant exposed to the air. The spraying increases the risk of desiccant carryover into the air stream. Oftentimes additional mist eliminator filters are used to capture any airborne desiccant particles. However, these mist eliminators require frequent maintenance and replacement. Furthermore, the process of using a filter media is inherently energy inefficient. The filter media is an obstruction in the air flow and thus generally requires large fan power. Also, the filter media typically are thermally non-conductive which makes the dehumidification process adiabatic resulting in undesirable heating of the air. To counteract the heating effect, one can increase the flow rate of the desiccant and one can pre-cool the desiccant to achieve some level of sensible cooling at the dehumidification stage in the filter media. Increasing the flow rate of course increases the risk of desiccant carry over and requires more liquid pump power. The liquid desiccant typically “rains” down from the filter media into a liquid desiccant collection pan. This generally prevents the liquid desiccant system from using a vertical air flow and requires more costly duct work to be used during the installation of the system on a buildings roof, where air is typically handled vertically. Furthermore, the drain pans do not easily allow the system to be set up as a “split” system wherein the conditioner and regenerator are located in physically separate locations. In addition, the drain pans do not easily allow for the system to be expandable: one has to increase the size of the pan—which means a new design, rather than adding capacity through a scalable design.

**[0011]** AIL Research has developed a low flow desiccant system that overcomes some of the objections mentioned above. The use of a heat transfer fluid in-situ to where the desiccant is dehumidifying the air results in better thermal performance and lower fan and pump power. However this approach still utilizes a horizontal air flow—which makes it much harder to integrate to a rooftop installation—and a very complex conditioner design that has a desiccant drain pan at the bottom, but does not allow for a counter flow between the

air and the liquids. This system also still has the risk of desiccant carryover since the desiccant is still directly exposed to the air flow.

**[0012]** The source of heat and the required temperature for regeneration of the desiccant is also an important consideration in the design of a solar air conditioning system. It should be clear that the lower the regeneration temperature of the desiccant is, the easier it should be to find a source of such (waste) heat. Higher regeneration temperatures necessitate higher quality (temperature) heat sources and thus are less easily available. At worst, the system has to be powered by a non-waste heat source such as a hot water furnace. Yazaki absorption units have been powered by evacuated tube solar thermal modules that are able to generate heat as high as 100° C. Concentrated solar thermal modules are able to achieve even higher temperatures, but oftentimes do so at higher costs. Glazed flat plate solar thermal collectors typically operate at somewhat lower temperatures of 70-80° C., but also lose a significant portion of their efficiency at higher temperature, which means that the array size needs to be increased to generate adequate power. Unglazed flat plate solar thermal collectors have higher efficiencies at lower temperatures, but generally lose a lot of their efficiency at high temperatures and are usually not able to achieve temperatures higher than 60° C., making them unsuitable for integration with absorption chillers.

**[0013]** None of the solar heat sources mentioned above (concentrated solar thermal, evacuated tube collectors and glazed and unglazed flat plate collectors) generates electricity at the same time as generating heat. However, all air conditioning systems still require electricity for fans and liquid pumps. Electricity is oftentimes much more expensive per unit of energy than fuels used for heat. It is therefore desirable to have an energy source that can provide heat as well as electricity.

**[0014]** It is known that solar Photo-Voltaic Modules (PV modules) heat up significantly in direct sun exposure with temperatures approaching 70-80° C. Such temperatures have a deteriorating effect on the performance of the module since module performance degrades with an increase in temperature. Applying a thermal transfer fluid to the back of the PV module (a module known as a PVT (PV-Thermal) module) effectively draws the heat from the module, lowering its temperature and increasing its efficiency. The thermal transfer fluid (typically water or water and propylene or ethylene glycol) can reach temperatures and thermal efficiencies typically between those of a glazed and an unglazed solar thermal module.

**[0015]** From a cost perspective, solar thermal systems augmented with conventional PV modules are less cost effective than PVT modules and take up more space than PVT modules. However, PVT modules generally supply lower temperatures and efficiencies than pure solar thermal systems. But beneficially they generate more electricity than conventional PV modules.

#### BRIEF SUMMARY

**[0016]** As discussed in further detail below, various embodiments disclosed herein are directed to methods and systems for air conditioning, capturing combustion contaminants, desalination, and other processes using liquid desiccants.

**[0017]** In accordance with one or more embodiments, solar Photo Voltaic-Thermal (PVT) modules are connected to a

desiccant air conditioning system to heat desiccants. The PVT modules can be connected in various arrangements for summer cooling and winter heating. The air conditioning systems can include both horizontal and vertical air flow desiccant systems, including spray-head desiccant systems.

**[0018]** In accordance with one or more embodiments, the PVT modules can be used to provide cold water for a desiccant system for summer cooling.

**[0019]** In accordance with one or more embodiments, the PVT modules can be used to provide heat for water going to a humidifier of air in a desiccant air conditioning system.

**[0020]** In accordance with one or more embodiments, the air conditioning systems can include a set of hollow plate structures used to expose desiccant to an air flow. In accordance with one or more embodiments, the plate structures have a wavy shape aspect to them. The hollow wavy plate structures are constructed in such a way that the surface tension of the liquid desiccant is used to draw the liquid desiccant into a drain channel. In accordance with one or more further embodiments, a sheet material such as a membrane or wetting material can be arranged on the wavy plates to guide a liquid desiccant into the drain channel. A membrane can be a micro-porous membrane with pores ranging in size from typically from 0.01  $\mu\text{m}$  to 1  $\mu\text{m}$ . An example of such a membrane is a membrane made by Celgard of Charlotte, N.C., and a division of Polypore Corporation, under the type designation EZ2090.

**[0021]** In accordance with one or more embodiments a membrane is a micro-porous membrane backed by a material intended to evenly distribute a liquid. In embodiments a membrane is a hydrophobic microporous membrane. In embodiments the backing material is a hydrophilic material such as a wicking material. An example of such a wicking material is the interfacing material made by the Pellon Company of New York, N.Y.

**[0022]** In accordance with one or more embodiments, the wavy plate structures are arranged in the air conditioning system such that the liquid desiccant is exposed to a vertical air flow without substantially obstructing the air flow.

**[0023]** In accordance with one or more embodiments, multiple sets of wavy plate structures can be arranged into a stack that has a scalable nature wherein the drying or wetting capacity of the desiccant can easily be expanded by simply adding additional wavy plates.

**[0024]** In accordance with one or more embodiments, a membrane desiccant system is provided for an air conditioning system using counter-flows of liquids and air in a vertical air flow system.

**[0025]** In accordance with one or more embodiments, a membrane desiccant system is provided wherein a membrane or other hydrophobic material is bonded to a wetting or other hydrophilic material in such a way as to provide proper distribution of a liquid behind the membrane. In embodiments to a double layer is bonded to a (thermally conductive) hydrophobic structure such as a plastic cooling channel or support plate.

**[0026]** In accordance with one or more embodiments, the plate construction allows for spreading a liquid desiccant at the top of a plate and for collecting such desiccant at the bottom of the plate.

**[0027]** In accordance with one or more embodiments, the air flow going to a vertical air flow desiccant set of wavy plates is preheated, and the air leaving a set of plate structures is post-cooled.

**[0028]** In accordance with one or more embodiments, plate structures are constructed and assembled in such a way that the plates can thermally conduct heat, but are still corrosion resistant by employing a thermally conductive plastic material. In embodiments such a plastic has a thermal conductance of about 5 to 10 W/mK. As an example thermal conductances for regular plastics range from 0.1 to 0.5 W/mK, whereas Copper, Aluminum, Stainless Steel and Titanium have a conductance of about 400, 250, 16 and 18 W/mK respectively. Of these materials only Titanium is reasonably suitable for use with desiccants such as  $\text{CaCl}_2$  or  $\text{LiCl}_2$  due to the corrosive nature of the desiccants.

**[0029]** In accordance with one or more embodiments, plate structures are assembled using a header that can be stacked vertically as well as horizontally in such a way that the wavy plates can be stacked parallel to each other as well as on top of each other.

**[0030]** In accordance with one or more embodiments, plate structures are assembled in such a way that a membrane is mounted on each plate to guide liquid desiccant to a header at the bottom of the wavy plate.

**[0031]** In accordance with one or more embodiments, the air inlet to the plate structures is disturbed by a mesh or set of disturbance plates in such a way as to create turbulent air movement in the air entering the wavy plates.

**[0032]** In accordance with one or more embodiments, a solar inverter is integrated an air conditioning system in such a way that the electrical connections to the air conditioning system provide the electrical connection to the building for a set of solar modules. In some embodiments, the air conditioning unit is a desiccant air conditioning system. In some embodiments, the desiccant air conditioning system uses vertical air flows. In some embodiments, the solar modules are PVT modules.

**[0033]** In accordance with one or more embodiments, a liquid desiccant vertical air flow system utilizes a chiller as a source of cold water and a gas water heater as a source for warm water, wherein the gas water heater is supplemented by the heat generated by solar modules.

**[0034]** In accordance with one or more embodiments, a PVT module provides electrical power and heat to a desiccant air conditioning system and provides heat to a water storage tank. The hot water can gradually be stored in tanks underneath the PVT modules, and the electrical power can be used to operate the air conditioning system. Any excess electrical power can be provided to other devices.

**[0035]** In accordance with one or more embodiments, PVT modules are set up in such a way as to radiate heat during the night, and thus provide cooling of water. Such cooled water can be stored in water storage tanks so that it can be made available during the day for the cold side of a desiccant air conditioning system. In some embodiments, such cold water can also be generated at night using an evaporative chiller in combination with the PVT modules.

**[0036]** In accordance with one or more embodiments, a PVT module generates hot water that is regulated by a thermostatic switch so as to enter a tank or flow directly to a manifold. In some embodiments, the thermostatic switch is driven by the temperature of the hot water. In some embodiments, the switch is operated by remote control.

**[0037]** In accordance with one or more embodiments, water is stored in a tank underneath a PVT module in such a way that the tank provides adequate evenly distributed weight to function as a ballast and support system for the PVT module. In

some embodiments, the tank has a removable lid. In some embodiments, the tank can furthermore function as a shipping container for the module.

**[0038]** In one or more embodiments, PVT modules are connected to a plate structure desiccant system. In some embodiments, the wavy plate system is set up to provide cool air to a building. In some embodiments, the wavy plate system is set up to provide warm moist air to a building space.

**[0039]** In accordance with one or more embodiments, PVT modules are connected so that they preheat water that is destined to go into a humidifier for air destined for a building space.

**[0040]** In accordance with one or more embodiments, a desiccant is separated into various layers in a vessel wherein the concentration of the desiccant varies along the height of a vessel. In some embodiments, the vessel is used to provide and collect desiccant to a desiccant air conditioning system. In some embodiments, at least one of the outlets of the vessel is adjustable so that different layers with different desiccant concentrations can be selectively drawn from the vessel.

**[0041]** In accordance with one or more embodiments, a portion of an air flow treated by a plate conditioner in such a way that the humidity is reduced is diverted to an additional set of plates that provides cooling of the air through evaporation of water vapor. In some embodiments, such a system uses membranes on the surface of the plates. In some embodiments, the air flow across the second set of plates can be reversed and the water for evaporation replaced by a desiccant in such a way that during winter operation, it provides additional heating capacity of the air entering the building.

**[0042]** In accordance with one or more embodiments, a set of plate structures provides an evaporative cooling effect and the so produced chilled liquid is directed to both a conditioner as well as one or more liquid to air heat exchangers. In embodiments such liquid to air heat exchangers are ceiling panels. In embodiments such liquid to air heat exchangers are fan coils. In embodiments such fan coils are located inside ductwork. In embodiments such liquid to air heat exchangers are located underneath a floor.

**[0043]** In accordance with one or more embodiments, a series of holes is provided at the top of the membrane to inhibit vacuum lock and allow for easy draining of desiccant from behind the membrane covering a plate structure.

**[0044]** In accordance with one or more embodiments, a plate structure is constructed in such a way as to provide alternating access to water and liquid desiccant on the surface of the plates by providing holes on an asymmetrical pattern.

**[0045]** In accordance with one or more embodiments, a heat exchanger is constructed using thermally conductive plastic plates to provide heat transfer between corrosive fluids. In some embodiments, such a plate heat exchanger uses horizontal and vertical counter flows. In some embodiments, the thermally conductive plates are formed in such a way as to have ridges and features that promote heat exchange and are constructed so that they can be stacked and sealed. In some embodiments, the thermally conductive plastic plates are not formed, but rather a gluing material is used to create and attach ridges on the top and/or on the bottom of the plastic plates. In some embodiments, the gluing material is also used to provide a seal to the liquids in between the plates. In embodiments the glue ridges are shaped in such a way that the ridges on the lower plate are supporting the ridges on the top of the upper plate, while the seal glue spans the entire gap



between the two plates. In embodiments, the glue material is Marine 5200, made by 3M Corporation of St. Paul, Minn.

**[0046]** In accordance with one or more embodiments, a first set of plate structures is contained in a hermetically sealed container and wherein a second set of plates is contained on the opposite side of the container. The first set of plates contains an optional membrane over its surface or a wetting material. The first set of plates receives a diluted desiccant from a desiccant source. The first set of plates also receives a heated heat transfer fluid from a source. A fan provides air movement inside the hermetically sealed container in such a way that water vapor is taken from the first set of plates. The second set of plates is relatively cool compared to the air environment and the enclosure in such a way as to cause condensation of water on its surfaces. The water can be withdrawn from the sealed enclosure. In some embodiments, the second set of plates is cooled by an external cold source.

**[0047]** In accordance with one or more embodiments, a set of plate structures with a liquid desiccant exposed to its surface collects moisture from an air stream and directs the diluted desiccant to a hermetically sealed container wherein the desiccant is regenerated and wherein the water vapor is recovered in the form of liquid water. In some embodiments, the heat for the system is provided by solar thermal modules. In some embodiments, the heat for the system is provided by PVT modules.

**[0048]** In accordance with one or more embodiments, a liquid desiccant is first regenerated in a hermetically sealed container and subsequently regenerated in an open array of plate structures. In some embodiments, the water recovered in the hermetically sealed container is diverted to a set of plate structures providing an evaporative cooling effect.

**[0049]** In accordance with one or more embodiments, fuel combustion takes place in such a way that the effluent gasses are directed through a set of plate structures having a liquid desiccant on its surfaces. The effluent gasses contain substances such as Carbon Dioxide, Water Vapor and contaminants such as  $\text{SO}_x$  and  $\text{NO}_x$ , which can be captured into the desiccant. In some embodiments, the desiccant is regenerated into a concentrated desiccant and liquid water. In some embodiments, the desiccant is filtered in such a way as to remove acidity created by the  $\text{SO}_x$  and  $\text{NO}_x$  and other gasses absorbed from the fuel combustion process.

**[0050]** In accordance with one or more embodiments, a desiccant draws water through a membrane from a water source such as seawater. The concentrated desiccant is diluted as a result of the transition of water through such membrane. The diluted desiccant is transported to a hermetically sealed enclosure wherein the desiccant is regenerated in such a way that concentrated desiccant and liquid water are produced. In some embodiments, the heat for regeneration is provided by solar thermal modules. In some embodiments, the heat for regeneration is provided by PVT modules.

**[0051]** Many construction variations can be envisioned to combine the various elements mentioned above each with its own advantages and disadvantages. The present invention in no way is limited to a particular set or combination of such elements.

#### BRIEF DESCRIPTION OF THE FIGURES

**[0052]** FIG. 1A illustrates a desiccant air handling system using a shower head design in accordance with the prior art.

**[0053]** FIG. 1B illustrates a desiccant air handling system using a plate design and horizontal air flow in accordance with the prior art.

**[0054]** FIG. 2A shows a desiccant air handling system set up for extreme summer operation with cold source and PV/Thermal module tie-in in accordance with one or more embodiments.

**[0055]** FIG. 2B shows a desiccant air handling system set up for non-extreme summer operation with cold source and PV/Thermal module tie-in in accordance with one or more embodiments.

**[0056]** FIG. 3A shows a desiccant air handling system set up for extreme winter operation with cold source and PV/Thermal module tie-in in accordance with one or more embodiments.

**[0057]** FIG. 3B shows a desiccant air handling system set up for non-extreme winter operation with cold source and PV/Thermal module tie-in in accordance with one or more embodiments.

**[0058]** FIG. 4 shows the integration between a building's existing air conditioning system, a desiccant air conditioning system and PVT modules in accordance with one or more embodiments.

**[0059]** FIG. 5 shows a desiccant system employing a vertical air flow in accordance with one or more embodiments.

**[0060]** FIG. 6A depicts a three-dimensional view of the system of FIG. 5 in accordance with one or more embodiments.

**[0061]** FIG. 6B depicts one or more turbulence plates that create air turbulence in the air entering a set of plate structures.

**[0062]** FIG. 7 shows the vertical air flow desiccant system with optional pre- and post air treatment coils and heat pump system in accordance with one or more embodiments.

**[0063]** FIG. 8 depicts details around the wavy plate structures in accordance with one or more embodiments.

**[0064]** FIG. 9 shows a possible construction for the wavy plate structures in accordance with one or more embodiments.

**[0065]** FIG. 10A shows an alternative method for wavy plate structure assembly, including the mounting of a membrane or wicking material in accordance with one or more embodiments.

**[0066]** FIG. 10B shows a cross section of two membranes with a hydrophilic wicking material sandwiched in between two hydrophobic membranes wherein the wicking material spreads a liquid uniformly between the two membranes in accordance with one or more embodiments.

**[0067]** FIG. 10C shows a cross section of a hydrophobic membrane, a hydrophilic wicking material and a (thermally conductive) support wall in accordance with one or more embodiments.

**[0068]** FIG. 10D shows a cross section of two membranes with two wicking materials and an internal (thermally conductive) support wall in accordance with one or more embodiments.

**[0069]** FIG. 10E shows a cross section of two membranes with two wicking materials and an internally hollow (thermally conductive) support wall in accordance with one or more embodiments.

**[0070]** FIG. 11A shows how the plate structures can be stacked into larger arrays and depicts construction details in accordance with one or more embodiments.

[0071] FIG. 11B illustrates desiccant system employing a horizontal air flow through two conditioners in accordance with one or more embodiments, wherein the air is treated twice by plates that are oriented at an angle to the air flow.

[0072] FIG. 11C shows a top view of the embodiment of FIG. 11B.

[0073] FIG. 11D shows the arrangement from FIG. 11B replicated twice in such a way as to treat the incoming air into a space and to recover energy from the returning air in a second set of conditioners in accordance with one or more embodiments.

[0074] FIG. 11E shows a desiccant membrane plate stack in the prior art that uses a portion of the dehumidified air for indirect evaporative cooling in accordance with one or more embodiments.

[0075] FIG. 11F illustrates a section of a desiccant membrane plate stack that uses a portion of the dehumidified air to provide indirect evaporative cooling in a controllable fashion

[0076] FIG. 11G shows a close up cut away detail for the bottom of the plate stack in FIG. 11F.

[0077] FIG. 11H illustrates further details of some of the components shown in FIG. 11F.

[0078] FIGS. 11I and 11J show a three dimensional and top view, respectively, of an embodiment that uses a tube structure for exposing liquid desiccant to air streams while providing a simultaneous heating or cooling functions in accordance with one or more embodiments.

[0079] FIGS. 11K and 11L illustrate a three dimensional and top view, respectively, of a hexagonal structure for exposing liquid desiccant to an air stream while providing heating or cooling functions in accordance with one or more embodiments.

[0080] FIG. 12 depicts a complete solar air conditioning system including a solar PV/Thermal array in accordance with one or more embodiments.

[0081] FIG. 13A demonstrates how storage and PVT modules can be used to create a hot/cold offset cycle for a desiccant air conditioning system during the day in accordance with one or more embodiments.

[0082] FIG. 13B demonstrates how storage and PVT modules can be used to create a hot/cold offset cycle for a desiccant air conditioning system during the night in accordance with one or more embodiments.

[0083] FIGS. 14A and 14B show a PV/Thermal module with integrated hot water storage/ballasting system in accordance with one or more embodiments.

[0084] FIGS. 15A and 15B show how the ballast tank and storage system can double as a shipping container for the PVT module in accordance with one or more embodiments.

[0085] FIGS. 16A and 16B demonstrate how PVT modules and cold sources can be integrated into the wavy plate desiccant system for summer operation in accordance with one or more embodiments.

[0086] FIGS. 17A and 17B demonstrate how PVT modules can be integrated into the wavy plate desiccant system and humidifiers for winter operation in accordance with one or more embodiments.

[0087] FIGS. 18A and 18B show how the heat from storage or PVT modules can be used during the day and during the night for air conditioning operation in accordance with one or more embodiments.

[0088] FIG. 19A shows how a desiccant concentration separator and evaporative cooler can be integrated into the

wavy plate system during summer operation in accordance with one or more embodiments.

[0089] FIG. 19B shows the system of FIG. 19A integrated to a building space wherein the chilled water that is produced by the evaporative cooler is not only used for cooling the conditioner but also used for cooling ceiling panels or floor panels.

[0090] FIG. 20A shows how the additional wavy plates in FIG. 19A can be used to increase heating capacity during winter operation in accordance with one or more embodiments.

[0091] FIG. 20B shows how a portion of the air entering a conditioner can be drawn out of the conditioner and diverted to a third set of wavy plates for winter operation.

[0092] FIG. 21A shows a corrosion resistant heat exchanger with thermally conductive plastic plates in accordance with one or more embodiments.

[0093] FIG. 21B shows a different embodiment of a corrosion resistant heat exchanger with thermally conductive plastic plates in accordance with one or more embodiments.

[0094] FIG. 21C shows the major manufacturing steps involved in using glue structures to construct a fluid to fluid heat exchanger in accordance with one or more embodiments.

[0095] FIG. 22 shows a water recovery system using plate structures in accordance with one or more embodiments.

[0096] FIG. 23 shows a desiccant system for heating and dehumidification in accordance with one or more embodiments.

[0097] FIG. 24A shows a heating and dehumidification system using the wavy plates and a water recovery system in accordance with one or more embodiments.

[0098] FIG. 24B shows a dual effect desiccant regeneration system which uses recovered liquid water for indirect evaporative cooling.

[0099] FIG. 25 shows a desiccant air conditioning system which captures and condenses combustion gasses and recovers water in accordance with one or more embodiments.

[0100] FIG. 26 shows a desiccant air conditioning system setup for winter heating that also condenses water vapor and captures contaminants from the combustion process in accordance with one or more embodiments.

[0101] FIGS. 27A and 27B show a three-dimensional model of the system of FIG. 24A in accordance with one or more embodiments.

[0102] FIG. 28 shows the water recovery system of FIG. 22 integrated to a desalination system for water purification in accordance with one or more embodiments.

[0103] Like reference characters generally denote like parts in the drawings.

#### DETAILED DESCRIPTION OF PREFERRED EMBODIMENTS

[0104] FIG. 1A depicts a liquid desiccant air conditioning system as known in the prior art. A desiccant conditioner 102 contains a liquid desiccant in a bath 104. The liquid desiccant 104 can be any suitable solution that attracts water vapor from the outdoor air 110 that is blown into the conditioner 102. The air moves through a filter media 106 that usually comprises a convoluted surface that easily holds and exposes the desiccant to the air stream. Examples of desiccants include  $\text{CaCl}_2$  and  $\text{LiCl}_2$ . The filter media can be a cellulosic cooling tower fill material. Diluted desiccant 105 that has absorbed water drips from the filter media 106 into the desiccant bath 104. The spray head 107 distributes the concentrated desiccant evenly

across the filter media **106**. Dehumidified and cooled air **111** is directed into the building. A portion (usually around 10%) of the diluted desiccant **112** is brought through a heat exchanger **103** to a regenerator **101**. The majority of the desiccant **112** is brought back to the spray head **107** at the top of the conditioner **102** through an optional cold source **113**. The desiccant that is diverted to the regenerator **101** is heated in an optional heater **114** and pumped to a spray head **107'** similar to the spray head on the conditioner side. The heated desiccant falls onto a filter media **106'** and drips down **105'** into a desiccant bath **104'**. Return air from the building or outdoor air **108** is brought through the filter media and absorbs water from the desiccant such that moist hot air **109** is exhausted from the regenerator. As discussed earlier, the drawbacks of this system are that the absorption of water vapor into the desiccant is an almost adiabatic process resulting in heating of the air that is meant to be cooled. Furthermore the spray head can lead to some desiccant being carried over into the leaving air streams **111** and **109**. And lastly, the baths **104** and **104'** force the air flows **110** and **108** to be horizontal and vertical through the filter media. This makes installation on a building roof more complicated since the exiting air **111** needs to be ducted into a downward direction and the return air **108** from the building needs to be ducted into a horizontal aspect.

[0105] FIG. 1B is an alternate system known in the prior art. The conditioner **121** comprises a set of vertical plates **118** (which are constructed to be hollow inside) and a desiccant collector **120**. Chilled heat transfer fluid from a cold source **113** is brought inside the plates **118** and forms a U-shaped loop **116** internal to the plate. A concentrated desiccant **119** is run over the surface of the plates **118**. Outdoor air **110** is directed over the desiccant **119** in a horizontal orientation. The desiccant absorbs water vapor from the air and runs down the surface of the plates **118** into the desiccant collector **120**. The diluted desiccant **121** is pumped through a heat exchanger **103** to the regenerator **122**. The regenerator comprises a set of plates **117** that again are hollow and that have U-shaped channels **116'** in them. Diluted desiccant **119'** is again run over the surface of the plates **117** that are heated by the hot transfer fluid source **114**. Outdoor air or return air from the building **108** is used to absorb water vapor from the desiccant **119'**. The desiccant gets more concentrated as it runs down the surface of the regenerator and collects into the desiccant collector **115**. As in the previous example, the air flow in the desiccant system is primarily horizontal resulting in the need for additional ducts to be used for installation on a rooftop. A horizontal air flow would have been preferred because no duct work would have been necessary, but the desiccant collectors **115** and **120** generally block air from flowing vertically. Furthermore, the U-shaped channels do not allow for a counter-flow design between the air, desiccant, and cooling or heating fluids resulting in lower thermal efficiency of both the conditioner and the regenerator. As compared to the system in FIG. 1A, the liquid desiccant system in FIG. 1B uses lower fan power and lower desiccant pump power.

[0106] FIG. 2A shows a liquid desiccant system in accordance with one or more embodiments configured for extreme summer operation and so as to integrate with an optional heat pump **201**. A portion of the desiccant in the conditioner **102** is brought through a heat exchanger **202** that can be coupled to a PVT module array. Since the typical desiccant materials that are used are corrosive to metals, the use of a

heat exchanger is desirable. This also complicates the integration of the heat pump **201**; since the desiccant should not contact any metal parts, the heat transfer is made indirectly through a specially designed heat exchanger. As can be seen in the figure, desiccant is taken from the conditioner, is heated in the PVT modules **202** or by the heat pump **201** and sprayed into the regenerator **101**. Conversely concentrated desiccant is taken from the regenerator **101**, run through an optional cold source **203** or through the cold side of the heat pump **201** and into the conditioner.

[0107] In FIG. 2B a similar set up is shown for non-extreme operation. The main difference is that the desiccant from the conditioner is cooled, and put back into the conditioner side rather than also being transported to the regenerator. Desiccant only transfers to the regenerator through the heat exchanger **103**. Similarly the desiccant in the regenerator is only heated and put back into the regenerator itself rather than being put into the conditioner.

[0108] In extreme winter operation in FIG. 3A, the heat sources **201** and **202** are now heating the liquid desiccant as it is transported to the conditioner **102**. It is noted that the conditioner in the winter setup is used to add water vapor and heat to an incoming air stream **110** and conditions the air to have a higher temperature and humidity as it enters the building at **111**. It is also possible to add a humidifier **301** that can be preheated by another PVT module array **302** or by another source of thermal energy. Since the water that is brought into the humidifier **301** is not corrosive to metals, it is not per-se necessary to use a heat exchanger in **302**; the water can be heated directly by the PVT modules. It is further worth noting that the return air **108** from the building generally is higher in temperature and humidity than the outside air **110**. The regenerator **101** in this setup actually captures the heat and moisture from the return air and transports it to the outdoor air, resulting in much lower heating costs and the desiccant system is in this setup effectively functioning as an enthalpy recovery system.

[0109] In FIG. 3B a similar setup is shown as in FIG. 3A, except now the heat sources **201** and **202** are now used to heat the desiccant on the conditioner **102** side of the system directly. Similarly the cold side of the heat pump **201** can directly draw heat from the desiccant in the regenerator.

[0110] The cold source **203** in FIGS. 3A and 3B will in most cases not be needed during winter operation of the system. It is also noted that the desiccant in winter mode will need to be diluted which means that small amounts of water will need to be added on a regular basis in order to prevent overconcentration of the desiccant. This water can come from the return air from the building, but may still need to be supplemented from other sources.

[0111] FIG. 4 shows how the enthalpy recovery system from FIG. 3A can be integrated into an existing building air conditioner infrastructure. The building space **401** is connected by ducts **402** to the desiccant system from FIG. 3A. The existing air conditioner heat pump comprising compressor **403** releases heat through fan coil **405** and the incoming air can be supplementally heated by PVT modules **406** and an additional fan coil. The compressed gas expands at the valve **407** and is heated by the return air in fan coil **404** before returning to the compressor **403**. The above described setup significantly reduces the load on the air conditioning system by again recovering both heat and water vapor.

[0112] In FIG. 5 a new type of liquid desiccant system is shown. The conditioner **501** comprises a set of plate struc-

tures that are internally hollow. Optionally the plate structures can have a wavy shape applied to them. The term wavy as used herein refers broadly to a variety of convoluted structures, including serpentine or undulating shapes. A cold heat transfer fluid is generated in cold source **507** and entered into the plates. Liquid desiccant solution at **514** is brought onto the outer surface of the plates and runs down the outer surface of each of the plates. In some embodiments, the liquid desiccant runs in a wicking surface that significantly increases the area of desiccant exposed to the air stream **503**. In other embodiments—described further below—the liquid desiccant runs behind a thin membrane that is located between the air flow and the surface of the plates. Outside air **503** is now blown through the set of wavy plates. The liquid desiccant on the surface of the plates attracts the water vapor in the air flow and the cooling water inside the plates helps to inhibit the air temperature from rising. The plate structures are constructed in such a fashion as to collect the desiccant near the bottom of each plate thereby eliminating the need for a desiccant collector or bath as was shown in FIGS. 1A and 1B. The treated air **504** is now put in the building directly without the need for any additional ducts. Furthermore, since all flows of air, heat transfer fluids and desiccant are vertical, the system is thermally more efficient. The wavy shape of the plates has two primary advantages: air is more easily brought in contact with the surface of the plates since the wavy shape constitutes more of a convoluted path than a straight plate would have given. But importantly, the wavy shape allows for the plates to expand sideways without putting undue stresses on the connections for heat transfer fluids and desiccants at the top and bottom of the plates. This is particularly important since the wavy plates should be constructed from a material that is compatible with the desiccant being used, for example from a (thermally conductive) plastic material such as a thermally doped polymer extrusion. Typically such a plastic has a thermal conductance of about 5 to 10 W/mK. As an example thermal conductances for regular plastics range from 0.1 to 0.5 W/mK, whereas copper, aluminum, stainless steel and titanium have a conductance of about 400, 250, 16 and 18 W/mK respectively. Of these materials only Titanium is reasonably suitable for use with desiccants such as  $\text{CaCl}_2$  or  $\text{LiCl}_2$  due to the corrosive nature of the desiccants. The wavy plates in the regenerator **502** will expand under the higher temperatures for regenerating the desiccant. This can create thermal stresses on the assembly. The wavy shape helps to reduce those stresses by allowing the plates to expand sideways rather than in the vertical direction.

[0113] The liquid desiccant is collected at the bottom of the wavy plates at **511** and is transported through a heat exchanger **513** to the top of the regenerator to point **515** where the liquid desiccant is distributed across the wavy plates of the regenerator. Return air or optionally outside air **505** is blown across the regenerator plate and water vapor is transported from the liquid desiccant into the leaving air stream **506**. An optional heat source **508** provides the driving force for the regeneration. The hot transfer fluid **510** from the heat source can be put inside the wavy plates of the regenerator similar to the cold heat transfer fluid on the conditioner. Again, the liquid desiccant is collected at the bottom of the wavy plates **502** without the need for either a collection pan or bath so that also on the regenerator the air can be vertical. It should be clear to those skilled in the art that the wavy plates can be easily expanded to add additional cooling or heating capacity, that these plates provide for better heat transfer and that the

elimination of any bath or collection pan allows for the system to be directly mounted on a roof opening without the need for additional duct work. An optional heat pump **516** can be used to provide cooling and heating of the liquid desiccant similar to the method employed in FIG. 1A. It will be clear to those skilled in the art that the absence of a liquid bath or collection pan also enables the easy installation of the conditioner **501** in a remote location from other components in the system, such as are commonly used in what is known as “split” air conditioning systems. It will furthermore be clear to those skilled in the art that the system of FIG. 5 can be made relative small in size in such a way that the system could be integrated into an automobile or other vehicle. In such an automobile the heat source **508** can potentially be the heat from an engine and cooling could be provided by a Peltier cooling system.

[0114] In FIG. 6A the system of FIG. 5 is shown in a 3 dimensional projection. Desiccant fluid pumps **601** provide the transportation of the desiccant between the conditioner and the regenerator. The holes **602** at the top of wavy plates **501** and **502** ensure an even distribution of desiccant over the surface of the wavy plates. Groves **603** at the bottom of the wavy plates **501** and **502** collect the desiccant by using either the natural surface adhesion of the desiccant to the plastic of the wavy plates to gather the desiccant into the groove or by using some membrane or other wetting material to help collect the desiccant into the groove. The heat transfer fluid can be connected to the wavy plates at connections **604**, **605**, **606** and **607**.

[0115] FIG. 6B shows how the inlet air **652** of a set of wavy plates **502** can be made turbulent by a set of plates **651**. The plates **651** are constructed in such a way as to impart turbulent airflow to the air entering the wavy plates **502**. The resulting turbulent air will better exchange heat and moisture with the surface of the wavy plates as compared to air that flows through the wavy plates in laminar fashion.

[0116] FIG. 7 depicts the system similar to FIG. 5 with the addition of a post conditioner cooling coil **702** and preheating coil **701** for the regenerator. An alternate configuration for the heat pump **705** is to instead of heating the desiccant as in FIG. 5, to heat the heat transfer fluid with heat exchanger coils **703** and **704**. This eliminates the need to have the heat exchanger use corrosion resistant components allowing for a more standard heat exchanger to be used.

[0117] FIG. 8 shows a close-up view of one embodiment of the wavy plate assembly where the desiccant drain **801** at the bottom of the plates collects the desiccant that has run into the groove **811**. Heat transfer fluid is connected to the plates at **802** and **805**. The main body of the wavy plates **803** can be made from a suitable material that exhibits good thermal conductivity as well as corrosion resistance, for example a thermally conductive plastic extrusion. Liquid desiccant is entered into the distribution channel **806** at the top of the plates **807** and exits the holes **810** at the top of same plates and runs over the surface **804**. The heat transfer fluid **808** runs inside openings **809** in the wavy plates. As can be seen from the figure the construction of the grooves **811** allows the desiccant to collect at the bottom of each individual plate without obstructing the air flow and without the need for a separate common collection pan. It should be obvious to those skilled in the art that the entering air stream **812** and exiting air stream **813** can be reversed and also that the direction of the heat transfer fluid between **802** and **805** can be

either upwards or downwards. The desiccant itself would normally run down the surface because of the force of gravity acting on the desiccant.

[0118] FIG. 9 shows further details of one embodiment of the construction of such wavy plates. A component 901, which is preferably an injection molded plastic component, is bonded on the thermally conductive extrusion 902. It should be obvious to those skilled in the art that other manufacturing methods can be employed such as machining, thermoforming, welding and other suitable methods. Other materials for the components can be suitably selected to be compatible with the corrosive nature of typical desiccant solutions, for example Titanium and other noble materials. A similar component 903, also preferably injection molded, is bonded to the top of component 902. Desiccant is introduced through inlet 905 and spreads generally evenly through the holes 904. Heat transfer fluid is transferred through the openings 905 and exists through the openings 907. Desiccant that has run to the bottom of the wavy plates is collected by taking advantage of surface tension in the liquid into the groove 811 and runs through the drain exit 906.

[0119] FIG. 10A shows an alternative embodiment of a wavy plate construction in which components 1001 and 1002, which are preferably injection molded, are connected to the top of a wavy plate 1003. Spreader plates 1013 cause the desiccant and heat transfer fluid to be generally evenly distributed. In one embodiment an additional injection molded component 1004 provides the collection of the heat transfer fluid inside the wavy plate 1003. A membrane or other suitable material such as a wicking material 1005 is applied over the top of the assembly. An example of such a membrane is hydrophobic Poly Propylene manufactured by Celgard under the tradename EZ2090. An example of a wicking surface is a hydrophilic cardboard sheet material similar to coffee filter paper. The completely mounted assembly 1007 is then connected to a final injection molded component 1006 in such a way that the membrane or wicking material guides the desiccant into the component 1006. In the final assembly 1008 the liquid channels for the desiccant 1009 and 1012 are shown, as are the channels for the heat transfer fluid 1010 and 1011. If the material 1005 comprises a membrane, then draining the liquid desiccant from the wavy plates can become a challenge since the top of the assembly can “lock” the desiccant in place (also known as vacuum lock). Holes 1014 are purposely provided to allow air to enter behind the membrane so that the liquid desiccant can easily fill and drain behind the membrane. These holes also keep the membrane from accidentally getting pressurized, which could result in damage or deformation of the membrane. Advantageously, the holes are located slightly above the outlet of the desiccant as can be better seen in FIG. 11A. It can also be seen in 1008 that two wavy plate assemblies have been joined together to form a small stack of plates. It should be obvious to those skilled in the art that the assembly of wavy plates can so be stacked as to generate any amount of air treatment as desired by simply adding additional plates to the stack.

[0120] FIG. 10B shows a detailed cross section of two hydrophobic materials such as membranes 1051 with a hydrophilic wicking material 1052. Since micro-porous membranes or similar materials are usually made to be hydrophobic, the application of a membrane can have non-uniform wetting caused by the liquid (such as—by way of example—a salt solution or water) to be repelled by the membrane. The repellent forces result in non-uniform flow of liquid on the

back of the membrane. By using a hydrophilic material 1052, the wicking effect of the hydrophilic material causes the liquid to evenly distribute behind the membrane resulting in significantly increased evaporation through the membrane and a significantly increased active area. A liquid running inside the wicking material will spread uniformly between the two membranes.

[0121] FIG. 10C shows a hydrophilic material 1052 behind a hydrophobic material such as a membrane 1051, attached to a thermally conductive support wall 1053 (which can be, e.g., a wavy plate). If the support wall is also hydrophobic such as is often the case with plastics and the like, then the wicking material will ensure even flow distribution of the liquid. The support wall can be made to be thermally conductive which would allow one to adjust the temperature of the liquid inside the wicking material and thereby control the evaporation of absorption through the membrane.

[0122] FIG. 10D shows a similar structure as in FIG. 10C wherein the wicking material is applied on both sides of the (thermally conductive) support wall 1053. The liquids inside the wetting materials 1052 on each side of the wall can now be made to be different. For example, the leftmost wicking material could be wetted with a salt solution and the rightmost wicking material could be wetted with water or some other heat transfer fluid.

[0123] FIG. 10E shows a structure similar to FIG. 10D wherein the support wall 1053 is now made to be hollow such that a heat transfer liquid 1054 can be used inside the support wall. Such a structure allows heat transfer from the heat transfer fluid 1054 through the walls into the wicking materials 1052 on either side of the wall 1054. It should be obvious to those skilled in the art that other combinations of hydrophobic and hydrophilic materials can be devised.

[0124] FIG. 11A depicts additional details of the construction of such as stack of wavy plates. A stack of wavy plates 1101 can be set up to treat air multiple times by stacking the plates vertically as well as horizontally. Vertical stacking allows air to be treated for instance to increase dehumidification, whereas horizontal stacking increases the overall capacity of treated air. Detail 1102 shows a detail of the bottom of the wavy plate construction in which the membrane or wicking surface 1005 is used to guide the desiccant into the bottom drain 1006. The lower edge 1111 of the membrane or wicking material is not fixedly connected so as to avoid potential pressure buildup of desiccant which could lead to damage of the membrane or wicking surface. Detail 1107 shows the same area as detail 1102 except with the membrane 1005 removed. The channels 1109 and 1110 that are created in the components 1004, 1006 and 1003 allow for the membrane 1005 to be bonded, but still allow for the desiccant to pass through the channels. Similarly detail 1103 of the top of the wavy plate assembly shows how the desiccant is able to enter through supply channel 1012 and run through the channels in components 1002 and over the surface of wavy plate component 1003. It should be clear from the details that the holes 1014 and the unconnected edge 1111 at the bottom advantageously serve the function to 1) inhibit vapor lock at the top of the assembly and 2) to avoid pressure damage to the membrane or wicking surface at either the top or the bottom of the assembly. Again detail 1108 shows the same top assembly with the membrane 1005 removed. Since the surface area of the wavy plate assembly 1101 is important for the overall air treatment capacity of the system, it should be easy to stack multiple wavy plates in both the horizontal and vertical direc-

tion as discussed above. Features **1104**, **1105** and **1106** allow for stacking of plates by aligning and locking plates together. It should be clear to those skilled in the art that such features can have many shapes and sizes.

[0125] FIG. 11B shows a system setup similar to FIG. 5 wherein the wavy plates are accepting a horizontal air flow. In the figure the wavy plates form two stacks in such a way as to treat the air passing through twice. By placing the wavy plates at a small angle to the incident air, the air will interact more readily with the liquid desiccant on the surface of the wavy plate. Such liquid desiccant can be located behind a membrane or in a wetting material as described before. By maintaining the wavy aspect in the vertical direction, any thermal stresses caused by thermal expansion and contraction of the wavy plates are significantly reduced.

[0126] FIG. 11C illustrates the setup from FIG. 11B in a top-down view.

[0127] FIG. 11D shows the dual set of wavy plates from FIG. 11B implemented twice. The first set treats air coming from outdoors and performs a double treatment of this incoming air. The second set receives return air from a space and also treats it twice. In such a setup the recovery of energy (water vapor and thermal energy) can be near complete. This setup allows for energy recovery while still allowing thermal energy to be added or removed and water to be added to air coming through the plate system through the desiccant, thereby enhancing the heating or cooling of the incoming air. Conventional energy recovery systems typically do not allow for the addition or removal of thermal energy or water.

[0128] FIG. 11E illustrates a desiccant cooling system in the prior art. A stack of plates **1134** is placed (typically about 0.25 inch apart) and is covered by a membrane **1131** that has water **1133** flowing behind it. The opposite site of the plate contains a second membrane **1135** behind which a liquid desiccant is flowing. Incoming air **1136** is dehumidified because water vapor in the air is absorbed into the liquid desiccant through the membrane **1135**. At the exit of the plates, the dehumidified air **1137** is partially directed towards the space being cooled and a portion is directed in the reverse direction **1138**. This secondary air flow **1138** is relatively dry and can effectively absorb water vapor from the water **1132** behind the membrane **1135**. The absorption of water vapor through the membrane into the air leads to a cooling effect of the diverted air. This cool air in turn cools the water **1133**. The cool water then thermally cools the plates as well as the liquid desiccant which ultimately leads to the main air stream being cooled. This approach allows evaporative cooling to occur in climates such as Miami, Fla. where humidity levels and temperatures are relatively high so that cooling towers normally do not function as well. By first drying the incoming air and then using indirect evaporative cooling through the membrane, the system is able to use evaporation to create a cooling effect. To inhibit the secondary air from mixing with the outdoor air, it is diverted by diverter **1139** near the end of the plate stack in a direction **1140** perpendicular to the drawing. As can be seen in the figure, the membrane/liquid layers are mirrored—water is facing water and desiccant needs to face desiccant for each of the plates. This creates a challenge for manufacturing such a plate stack.

[0129] FIG. 11F illustrates an embodiment of the concept of FIG. 11E wherein wavy plates **1147** are used to provide an alternating structure for liquid desiccant and water. In some embodiments, the wavy plates are made using thermally conductive plastics. The wavy plates contain ridges **1146** to sup-

port the membranes **1131** and **1135**. Liquid desiccant enters the wavy plate set through channel **1141** and exists through channel **1144**. Water enters through channel **1142** and exits through channel **1143**. An adjustably connected air diverter **1145** takes a controllable amount of air in directs it in the reverse direction **1138**. The diverted air **1138** absorbs water from behind the membrane **1135**. The diverter **1139** closes the top of the opening between the plates and directs the airflow **1140** in a perpendicular direction. The bottoms and tops of the wavy plates **1147** are inserted into an injection molded component **1006** similar in design to FIG. 10A.

[0130] FIG. 11G shows a detail of FIG. 11F wherein a close-up of the wavy plates **1147** that have the membranes **1131** and **1135** mounted to the ridges **1146** on the wavy plates. In order to provide liquid to opposite faces of the wavy plates, holes **1150** and **1151** are provided in such a way as to provide access to alternating sides of the wavy plates **1147**. The liquid desiccant enters the drain channel **1144** through the holes **1152**. As can be seen from the figure, the wavy plates **1147** can be made to be generally identical, except that the wavy plates are flipped upside down in an alternating fashion.

[0131] FIG. 11H shows a detail of the wavy plates **1147**. The wavy plates are alternatively flipped upside down to provide opposing connections to the water and desiccant supply lines. As can be seen in the figure, the ridges **1146** provide support for the membrane and the thermally conductive surface **1134** provides a thermally conductive path to the opposite side of the wavy plate. The holes **1153** provide a uniform distribution of the liquids similar to the holes in component **1013** in FIG. 10A.

[0132] In various embodiments described herein, wavy plate structures are used to expose a liquid desiccant to an air stream through a membrane while simultaneously exposing the liquid desiccant to a heat transfer fluid. Various alternate structures can also be used to perform these functions. For example, FIGS. 11I and 11J illustrate a tubular structure for exposing a liquid desiccant to an air stream through a membrane while simultaneously exposing the liquid desiccant to a heat transfer fluid. The structure comprises a plurality of tubes **1181** that can be made from any suitable thermally conductive material for example from a thermally doped polymer extrusion. The inner wall of the tube can feature ridges **1184** to allow a membrane **1182** to be bonded to the top of the ridges in such a way that the membrane is held at a small distance to the tube wall so that liquid desiccant can pass between the wall and the membrane perpendicular to the plane of the figure in the so created channel **1183**. Air can thus be passed in the center of the tubes **1186**, while heat transfer liquid can pass in the generally triangular sections **1185** between tubes. The heat transfer fluid is thus able to heat the desiccant solution through the thermally conductive walls. It should be understood that other shapes and arrangements of tubular structures can also be devised. FIGS. 11I and 11J also show that it would be possible to apply some wavy shape to the tube which as in the previous embodiment functions to achieve better interaction between air and desiccant while at the same time reducing stresses due to thermal expansion in the vertical direction of the structure.

[0133] FIG. 11L is a top view of an alternate hexagonal structure of thermally conductive surfaces **1192** in accordance with one or more embodiments. FIG. 11K is a three-dimensional view of one of the hexagonal elements forming the hexagonal structure. Each hexagonal element in the structure includes thermally conductive surfaces **1192**. Ridges

**1194** allow membranes **1191** to be mounted substantially parallel to the thermally conductive surfaces. The channels between the membrane **1191** and the walls **1192** in some of the elements can be used for passage of a heat transfer liquid or alternately for passage of water to perform an evaporative cooling function in a similar manner to the system described in FIG. **11E**. In the example shown in FIG. **11L**, the hexagonal elements with channels between the membrane **1191** and the walls **1192** shaded in gray contain water, and the channels in the other hexagonal elements contain liquid desiccant. Thus, air in channels **1195** can be exposed to the liquid desiccant through the membranes, while already treated air **1196** can be exposed to water through the membranes.

[**0134**] FIG. **12** shows how the wavy plate assemblies discussed above can be integrated into a full solar air conditioning system. The enclosure **1201** provides protection of the desiccant air components from the weather. The system includes the conditioner **501** and the regenerator **502**. Pumps **601** provide desiccant flow to the conditioner and regenerator. Blowers **1209** move air into and out of the building. Outdoor air **503** is treated by the wavy plates and moved into the building as treated air **504**. Return air **505** from the building can absorb the heat and water vapor and is exhausted at **506**. A small optional chiller **1203** provides sensible cooling if needed. A solar inverter **1202** can invert the electricity coming from a series of solar modules **1205**. There is a significant advantage for integrating a solar inverter to an air conditioning system (whether it is a conventional air conditioner or a desiccant air conditioner): a rooftop air conditioning unit already has a significant electrical supply line going up to it. By integrating an inverter into a replacement air conditioning unit, the installation of PV or PVT modules is dramatically simplified. Normally a solar inverter is located somewhere inside the building and electrical lines are run from the roof to the inverter creating a significant amount of cost and labor. By locating a solar inverter inside an air conditioner there is no need to run any electrical cabling into the building, since the existing electrical lines to the air conditioner can be back-fed by the inverter to supply electrical power to the building. Also in the figure is shown a supplemental water heater **1204** that can be used when the PV-Thermal modules do not provide adequate temperatures or power. In addition the solar modules **1205** can have a water storage tank **1206** in such a way that access hot water can easily be stored. In this system the hot water tank **1206** is functions to provide ballast to the PVT module. Normally a concrete block or similar ballast would be provided to hold down solar modules on a flat roof. However, by using a thin flat tank like **1206**, we achieve two objectives: hot water storage as well as ballast. It should further be noted that each solar module can have its own storage tank. By integrating tanks **1206** below the PVT modules **1205**, all electrical lines **1207** and heat transfer fluid lines **1208** can be led to the desiccant system **1200** without the need for any lines entering the building or for installing tanks or inverters anywhere in the building thereby significantly improving installation time for the system.

[**0135**] FIG. **13A** illustrates how such a storage system as shown in the previous figure can be used. At the start of the day, **1301** the PVT modules **1304** start receiving solar radiation **1306**. The storage tanks **1305** underneath the PVT modules are generally filled with cold water (or some other heat transfer fluid). The PVT modules start generating hot water which is directed to the solar air conditioning system **1200**, and specifically to the regenerator **1310**. Since sensible cool-

ing also needs to be provided, one of the cold water tanks is connected to the conditioner **1309**. As the day progresses **1302**, the PVT modules will generate excess hot water which can be used to start filling up some of the tanks. The connection **1307** and **1308** are made in such a way that the correct number of tanks is connected to the air conditioner **1200**. At the end of the day **1303**, most or all of the tanks will contain hot water. This hot water can now be used to continue to run the regenerator during the evening and night by connecting the hot tanks through lines **1316** to the regenerator as shown in FIG. **13B**. Since PVT modules are also relatively efficient at shedding heat by radiation **1314**, the PVT modules can now be directly connected to the conditioner by lines **1315**. In the middle of the night **1312**, the radiation from the PVT modules can be used to start making cold water for storage in the tanks in such a way that by the end of the night all hot water has been used and cold water has filled the tanks underneath the modules. This allows the cycle to start over again. Effectively this arrangement allows the day to night shifting of cold and hot water generation, which can eliminate the need for any sensible cooling system such as the small chiller **1203** in FIG. **12**.

[**0136**] FIG. **14A** shows an embodiment of the solar PVT modules from FIG. **12** in some level of detail. The PV laminate **1401**, which can either be silicon or thin film based, generates the electrical power. The storage tank **1402** doubles as a hot liquid storage container as well as a ballasting system. FIG. **14B** shows a cut-out close-up of the system. A series of thin channels **1405** behind the laminate **1401** collect heat from the laminate and heats the transfer fluid. The main hot water channel **1404** brings water down to a thermostatic valve assembly **1403**. The thermostatic valve can direct hot water either directly to the main manifold **1406** or to the storage tank **1402**. The thermostatic valve can either be operated automatically or through a software control.

[**0137**] FIGS. **15A** and **15B** demonstrate another use of the storage tank underneath the PVT module. The storage tank in this case has a removable lid **1501** and a main body **1502**. The side and rear supports **1504** of the PV laminate **1503** are removably connected to the tank and the PV laminate. After removing the lid **1501**, the entire solar module and support structure can be put inside the tank body thereby protecting the solar module during shipment. This alternate use of the tank as a shipping container can be very helpful when solar modules have to be setup and disassembled on a regular basis for example as may occur for remote military basis. In effect, the tank now serves three functions: shipping container, storage tank and ballast system.

[**0138**] FIG. **16A** demonstrates a schematic of the setup of a solar air conditioning integrated to a desiccant system for extreme summer operation. All of the desiccant from the conditioner **501** is sent to the regenerator **502**. The advantage of the plate structures is that in effect the plate sets **501** and **502** are three way heat exchangers between air, liquid desiccant and a heat transfer fluid. This allows for PVT modules to be tied in at two places: directly heating the heat transfer fluid at **1601**, or heating the desiccant through a heat exchanger at **1602**. Similarly the cold connections for sensible cooling can either be made on the desiccant side **1604** or on the heat transfer fluid side **1603**.

[**0139**] FIG. **16B** shows a setup for summer non-extreme operation. The major difference with the previous case is that only a portion of the desiccant is sent through the heat exchanger **513**. The flows of desiccant at **1609** and **1610** can be adjusted so that only a portion of the desiccant is sent to the

regenerator. As in the previous case, the PVT modules can be tied in at two places: at the desiccant side **1606** and at the heat transfer fluid side **1605**. Again the cold connections can be made on either the desiccant **1608** or the heat transfer fluid **1607**. It will be clear to those skilled in the art that all the heat sources and cold sources can be supplemented by other sources tied into the same lines in parallel or in series to the PVT modules or cold sources in the drawings.

[0140] FIG. 17A shows a liquid desiccant system set up for winter heating in extreme conditions. Since active cooling of the leaving air is not necessary, the cold sources have been omitted from the drawings. Again PVT modules can be tied into desiccant side **1705** or the heat transfer fluid side **1706**. Since the heated desiccant will also emit water vapor additional water may have to be added at **1707** to prevent high concentrations of desiccant and potential crystallization of the desiccant salts. Furthermore the treated air **504** may require additional humidification **1703** which again can be done more efficiently by preheating the water at **1704** with PVT modules or another heat source.

[0141] FIG. 17B shows a similar setup to FIG. 17A except for non-extreme winter conditions whereby only a portion of the desiccant is sent through the heat exchanger at **1708** and **1709**.

[0142] FIG. 18A shows how the PVT module array from FIG. 13A can be connected to the liquid desiccant system. PVT modules **1804** receive heat and the hot heat transfer fluid is sent to both the desiccant regenerator **502** and the hot storage system **1803**. The cold side can draw cold water from the cold storage tanks **1805**. At night, FIG. 18B shows how the regenerator is now drawing from the hot storage tanks **1803** whereas the conditioner is radiating heat through the PVT modules **1804**, which at the same tank provide cool water in the cold storage tanks **1805**.

[0143] The setup from FIGS. 18A and 18B works well when there is a large temperature difference between night and day temperatures, e.g., as is the case in desert or in the central valley in California. However in other climates the temperature may not change as much and additional sensible cooling can still be required. As discussed before such sensible cooling can be provided with a small chiller or a heat pump. It should be clear to those skilled in the art that other means of cooling such as Peltier cooling or evaporative cooling could be employed. In climates such as Miami, Fla. evaporative cooling is not as effective in the summer due to the already high humidity levels.

[0144] FIG. 19A shows an alternative method for cooling that uses a portion of the dehumidified air **504** and directs it to a third set of plate structures **1904**. The diverted air flow **1903** is already treated and low in humidity. Instead of desiccant, the third set of plate structures has water running over its surface and behind a membrane or wicking surface, and has a heat transfer fluid internally to the plates **1907**. The diverted air is now directed between the wavy plates in effect creating what is known as an evaporative chiller using the wavy plates. Water is supplied to the third set of plate structures at **1905** and un-evaporated water is returned to the top of the plates through line **1909**. The portion of air **1903** that is diverted can be adjusted with louvers or baffles or some other suitable mechanism in such a way that the amount of air is variable. Varying the amount of air will regulate the temperature achieved in the building by the entering air **504**. As in FIG. 18B, PVT modules **1807** can be used at night to enhance the cooling effect and cold water can be stored in tanks **1805**. It

would also be conceivable to locate the third set of plate structures **1904** (partially) underneath the conditioner **501**. This will increase the height of the overall stack, but negates the need to redirect the air **504** in the opposite direction. Conversely it would also be possible to divert the air **504** out of the plane of the drawing and into the third set of wavy plates in a horizontal flow pattern. Locating the third set of wavy plates underneath the conditioner plates **501**, has as a disadvantage that reversing the air flow for winter operation such as is shown in FIG. 20A becomes impossible. However, drawing a portion of the air **504** out perpendicular to the plane of the drawing and sending it through the third set of wavy plates **1904** in a horizontal fashion, still will allow the air in the third set of plates to be used for winter heating as is shown in FIG. 20B.

[0145] In addition to the third set of plates, FIG. 19A shows another improvement to the desiccant system. Desiccant storage system **1902** uses the fact that dilute desiccant will physically separate from concentrated desiccant if flow rates are low and the desiccant has sufficient time to settle. In other words if left alone the concentration in tank **1902** will tend to increase going from the top to the bottom. One can take advantage of this effect by connecting the desiccant lines at the appropriate heights along the sides of the tank. One can also draw the desiccant from a variable height in the tank using a vertically adjustable drain **1908**. By moving the drain **1908** up, the system will draw lower concentration desiccant resulting in less dehumidification. In effect this gives the system a control capability for humidity in the building. Lowering the drain **1908** will decrease the humidity in the building but will also result in higher costs for the regeneration. In effect this now gives the system independent control over temperature of the air by adjusting the supplemental heating system **1901** is used when the PVT modules **1804** do not generate adequate heat.

[0146] It should be understood that various features and elements (such as, e.g., the tank **1902**) described in connection with particular embodiments, can also be implemented in other embodiments though not explicitly indicated.

[0147] FIG. 19B shows the system of FIG. 19A wherein the third set of wavy plates **1904** that function to provide chilled water to the conditioner **501** are now also providing chilled water **1956** to one or more ceiling panels **1955**, a so-called "chilled ceiling". This approach allows the chilled water produced in the third set of plates to also provide sensible space cooling in an integrated approach. The cooled and dried air **504** and **1952** is typically guided through a series of ducts **1953** and delivered to the space **1954** in the building **1951**. This approach allows for easily balancing of the buildings requirements for latent and sensible cooling by varying the number of plates in the plate sets and by adjusting the desiccant concentration which in turn affects the humidity in the space. It should be clear to those skilled in the art that instead of chilled ceiling plates a series of fan coils or other suitable liquid to air heat exchangers could be deployed.

[0148] FIG. 20A shows the system from FIG. 19A but set up for winter heating. Since oftentimes the heating capacity in the winter needs to be much larger than the cooling capacity in the summer, it is now possible to use the third set of wavy plates as part of the heating of the incoming air. Instead of flowing water over the surface of the third set of plates, the system is now using the liquid desiccant to treat the air. In winter mode the supplemental heater **1901** does not need to be used and neither does heat need to be applied to the heat transfer



fluid in loop **2001**. Instead the supplemental heater **2003** can be used to heat the heat transfer fluid in the conditioner wavy plate sets **501** and **1904**. Additional pre-heater coils **2006** can be used to heat the entering air **503** and **1906**. The desiccant **2002** that enters the regenerator **502** is picking up heat and water vapor from the leaving air **505**. As discussed for FIG. **17A**, this serves to reduce the heating requirements for the conditioner as the desiccant through piping **2004** transports this heat and water to the conditioners. Lines **2005** now connect the desiccant to also reach the third set of wavy plates. As winter conditions oftentimes require humidification to occur, additional water can be added through either the same system **1905** that is used for evaporative cooling in summer mode or by additional humidifiers **1703**.

[**0149**] FIG. **20B** shows how the air **2051** flows in substantially a vertical direction through the third set of plates **1904** during winter heating pushed by the fan **2053**. During summer cooling the air **504** is directed out of the plane of the drawing following the arrow **2052** and directed into a substantially horizontal flow direction by the fan **2054** which is substantially located behind the plane of the drawing and behind the third set of wavy plates **1904**. The advantage of this approach over the approach described in FIG. **20A** is that there is no need for a reversible air fan: instead a winter fan **2503** is used during heating season and a summer fan **2504** is used during cooling season. The fan **2505** on the conditioner is always directing air in the same vertical flow. A further advantage of this approach, besides the increase in winter heating capacity is that the entire area of the third set of plates is actively used in both winter and summer. The approach described in FIG. **11E** has as a disadvantage 1) that is not reversible for winter heating support, 2) that the effective area, particularly for the water channels **1138** is reduced due to the manner in which air flows through the evaporative channel **1138**, and 3) that the ratio of evaporative channels **1138** over desiccant channels **1137** is fixed, giving less flexibility to adopt the system to climates where maybe less evaporation is needed (sensible cooling) and more dehumidification (latent cooling). By separating the evaporative channels into a third set of plates, the flexibility is increased to adopt the system to various climate conditions.

[**0150**] FIG. **21A** depicts a plate heat exchanger in accordance with one or more embodiments. Since the desiccants used in these air conditioning systems are typically corrosive to metals, normal heat exchanger—which is typically constructed with metal—can not easily be used unless materials have been selected specifically for corrosive duty, which usually has a negative impact on cost. By using a flat plate construction wherein the entire units is made out of plastics, costs can typically be reduced. Desiccant enters the heat exchanger in two places, for example, hot desiccant enters at **2101** and exits as cold desiccant at **2103**, and cold desiccant enters at **2102** and leaves as hot desiccant at **2104**. The housing **2105** contains a plate **2106** assembly that has thermally conductive surfaces **2110**. Obstructions **2109** inside the plates **2106** create a long convoluted path for the desiccant. Vertical separators **2107** create a long convoluted path for the fluid flowing in the opposite direction to the fluid inside the plates. Cutouts **2108** in the vertical separators **2107** force the opposing fluid into an up-down and left-right direction. It will be clear to those skilled in the art that other construction approaches of thermally conductive flat plastic plates can be used as a heat exchanger.

[**0151**] FIG. **21B** shows an alternative arrangement of thermally conductive plastic plates for a heat exchanger. The heat exchanger **2150** comprises a stack of formed, thermally conductive plastic plates **2155** and **2157**. Cold liquid enters at **2151** and is heated through the plate assembly and exits as hot liquid at **2152**. Hot liquid enters at **2153** and exits cold at **2154**. Each of the plates contains a seal **2156** that is oriented in such a way the even plates **2155** allow for flow from lower left to upper right of the plates **2155** and odd numbered plates **2157** have a mirror image seal **2156'** that allows flow from the lower right to the upper left. The turbulence ridges **2158** cause the liquid flow to go up and down when it moves from the inlet to the outlet, thereby creating better heat exchange with the liquid in the next channel. The turbulence ridges can be created by forming them into the plastic plate **2155** and **2157** such as for example by thermoforming or casting the plastic. Alternatively, since the molding costs of forming plastics plates are substantial, it is possible to using a glue system to attached glue lines **2158** to the plates **2155** and **2157**. Such glue lines can be formed by a simple XY robotic gluing system for example using 3M Corporation's Marine 5200 Polyurethane glue. The sealant lines **2156** and **2156'** can also be formed using the same gluing system, except that the height of the sealant lines would be made about 2× the height of the turbulence lines **2155** and **2157**, in such a way as that when the plates are stacked the glue lines support each other and the seal lines cover the distance between the top and bottom plates.

[**0152**] FIG. **21C** is a cross section schematic view of the plate structure and exemplary manufacturing steps involved in using glue structures to construct a fluid to fluid heat exchanger as was shown in FIG. **21B**. As shown in FIG. **21C**, in step A, a plate **2155** preferably made from a thermally conductive, non-corrosive material is first placed in a machine that can evenly apply glue ridges **2158** in a predetermined pattern on one side of the plate. After the glue ridges are cured (step B), the plate is flipped over and a second set of glue ridges **2158** is applied to the opposite side of the plate (step C), in a similar or different pattern. A number of similar plates are thus constructed in this fashion. After the number of plates have cured (step D), a base **2161** of the heat exchanger is positioned and a glue pattern **2156** meant for sealing to the base is applied. Before curing can occur, the first plate **2155** is placed on the seal in such a way as to adhere to the underside of the first plate (step E). This process step is repeated with the other plates (step F). Finally, the top plate **2162** is placed with a glue seal **2156'** (step G). The advantage of this construction process is that it is very easy to make heat exchanger units with different materials, plastics as well as metals, with virtually no setup or tooling costs. Furthermore, one can easily change the size of the heat exchanger by simply enlarging the plates and re-programming the glue machine. Traditional heat exchangers typically use formed metal plates and thus every size change can require a new die for forming the metal. These heat exchangers also often employ a cast urethane gasket, so changing sizes also will often require a new casting mold.

[**0153**] In certain situations it could be desirable to capture the water vapor in outdoor air and turn it into liquid water, for example, to generate drinking water. FIG. **22** shows an arrangement whereby two sets wavy plates have been integrated into an enclosure **2201**. A first wavy plate set **2202** has—as before—a hot heat transfer liquid generated by a heat source **2211**. Desiccant from a source **2203** is directed to the

surface of the wavy plates **2201**. The heat from the source **2203** causes water vapor to evolve from desiccant on the surface of the wavy plates. Air **2205** that is driven between the plates by the fan **2206** absorbs the water vapor and is moved to the right side of the system. Since the complete system is enclosed and the air is unable to escape, the relative humidity in the enclosure **2201** will reach close to 100%. When the heated, moist air **2205** exits from the first set of wavy plates, it will be close to saturation. When that same air reaches the second set of wavy plates **2207**, the cold water loop **2208** causes the water vapor to condense on the surface of the wavy plates **2207** and is then collected at the bottom of the wavy plates **2207** in the form of liquid water that flows out of the system at **2210**. The cooler air **2204** exits the bottom of the wavy plates **2207** and is transported back to the first set of wavy plates **2202**, where it is heated again and where it absorbs water vapor from the desiccant, which starts the cycle over again. It is possible to add a vacuum pump **2209** so as to operate the system of FIG. **22** at reduced pressure. This would lower the required temperature to evolve water vapor from the desiccant on the first wavy plate set **2202**, but would make the system more complicated, for example one would also have to add a pump mechanism to retrieve the condensed water from the system at outlet **2210** and to prevent the backflow of the desiccant on the first set of wavy plates **2202**. An optional air to air heat exchanger **2212** could be added, but that could lead to condensation in the heat exchanger, which would be more difficult to recover. It should be clear to those skilled in the art that the condensation in the wavy plates **2207** could be accomplished in other ways such as a set of metal plates that are relatively cool as compared to the wavy plates **2202**. Since there is no desiccant involved in the condensation process, any suitable material such as metal plates can be used for the condensing component.

[0154] FIG. **23** shows a system that uses a liquid desiccant for the dehumidification of greenhouses. Conditioners **2322** and **2323** contain liquid desiccant conditioners as shown also in FIGS. **1A** and **1B**. The spray heads **2314** spray desiccant into a cooling tower fill **2315**, which dehumidifies the greenhouse air **2317**. Diluted desiccant **2316** rains down into a collection bath **2318**. Some of the desiccant **2324** is pumped through the heat exchanger **2320** and reaches a regenerator **2301**. The desiccant can be optionally heated by a PVT module heat source **2319** before reaching the desiccant collector **2304** that is part of the regenerator. Some of the concentrated desiccant in the collector **2304** is pumped to a heat exchanger **2306** and/or through an optional PVT module heating system **2305** before being sprayed into a filter material **2303**. The filter material **2303** is able to spread the desiccant over a large area while letting air through. Air **2302** is pumped by the fan **2309** through the filter material and picks up water vapor from the hot desiccant. The hot moist air is then transported to the other side of the regenerator where cold water is sprayed into the air at **2321**. Water condenses from the air and collects into a collection bath **2310**. Some of the water is pumped through lines **2312** to heat exchangers **2313** where the water is cooled by the air stream coming through the conditioners **2322** and **2323**. Excess water is drained at **2311**. The heat for the system is provided by water heater **2308** or optionally by the PVT modules **2307**. The heat exchanger **2306** is needed because the corrosion of the desiccant does not allow direct heating by the water heater.

[0155] FIG. **24A** shows a significantly more efficient water generation system. The wavy plate conditioner **2405** treats

the entering air **2406** and absorbs moisture as before into a desiccant running over the surface of the wavy plates. The leaving air **2407** is warmer and dryer than the entering air **2406**. Diluted desiccant is pumped through a heat exchanger **2404** and through an optional PVT module heater **2403** to the water recovery system **2200** discussed above. Since the wavy plates in effect comprise a three way heat exchanger, the system **2400** can be much simpler. Water heater **2402** and optional PVT modules **2401** heat a heat transfer fluid **2409** which runs through the wavy plates inside the water recovery system **2200** without the need for a heat exchanger. Similarly, cooling liquid in **2408** can run directly through the conditioner wavy plates **2405** without an additional heat exchanger. This simpler system is also more energy efficient since the air flow in the conditioner is less obstructed and since the heating and cooling in the wavy plates is done in-situ. As a result a lower temperature heat source such as the PVT modules can be used. Water is recovered again at **2410**.

[0156] The regeneration of dilute liquid desiccant should preferably be performed at high efficiency as well as at low temperature. Multiple effect regenerations are known in the art that have high efficiency, but generally also require high temperatures. High regeneration temperatures make it difficult or impossible to use “waste” energy sources or solar energy sources. Generally speaking lower temperature waste energy is more readily and cheaply available than high temperature waste energy. FIG. **24B** shows a combination of the water recovery system from FIG. **22** and the indirect cooling system of FIG. **19A**. By combining the water recovery system **2200** into the regenerator plate set **502**, the regeneration of desiccant becomes what is known as a multiple effect regenerator. The dilute desiccant **511** is first directed to the plates inside the water recovery system **2200**. Inside the wavy plates hot water **2409** is provided to evaporate water from the liquid desiccant. The liquid desiccant exits at the water generator at higher concentration and is directed to the plates at **515**. Hot water vapor inside the water generator **2200** heats the water loop **2408** which in turn heats the wavy plates **502** of the regenerator. Concentrated desiccant **512** is then returned through the heat exchanger **513** to be reused in the conditioner. One advantage of this system is that it can regenerate at higher efficiencies than a single effect regenerator, while still operating at lower temperatures. Furthermore the recovered water **2410** can be directed through water line **2451** and optional cooler **2452** to the evaporative section of the indirect cooling system from FIG. **19A**, thereby reducing or even eliminating the need to provide a water supply source.

[0157] FIG. **25** shows the system of FIG. **24A** with some additional improvements. Rather than sending all of the desiccant to the regenerator **2200**, the separator **2501** allows for the least concentrated desiccant near the top of the separator to be sent for regeneration and the most concentrated desiccant to be used again in the conditioner. Combustion of fossil fuels generally results in carbon dioxide and water vapor being produced. Other combustion byproducts are contaminants such as  $\text{NO}_x$  and  $\text{SO}_x$  and other residual by products. Gas burner **2502** produces these gasses if it is used in the space to be treated such as inside a greenhouse. Hot water coils **2503** absorb most of the heat generated by the burner. The hot water is used in the regenerator **2200**. Water vapor,  $\text{CO}_2$  and the contaminants such as  $\text{NO}_x$  and  $\text{SO}_x$  go through the hot water coils and enter the wavy plates **2405**. The  $\text{CO}_2$  is desired in the greenhouse, but water vapor and other contaminants are not. In effect the wavy plates function as what

is known as a condensing boiler by absorbing the water in the combustion exhaust, which releases additional heat and makes the overall combustion process more efficient. But unlike a condensing boiler the desiccant is also able to absorb some of the contamination in the burner effluents. The desiccant transports these contaminants with the water to the regenerator **2200** where supplemental filters **2411** can be employed to filter these contaminants out of the desiccant or out of the air stream in the regenerator. The arrangement in FIG. **25** allows for burning of fuels such as biogases that are not as clean burning as natural gas. Also shown in the figure is an additional external cooling coil **2504** that can be added to aid in the condensation of the water.

[**0158**] FIG. **26** shows how some of the concepts discussed in the previous figure can also be integrated into winter heating system as discussed in FIG. **17**. Water heater **2602** uses a gas burner **2601**. The heated water **2604** can also be heated by the PVT modules **1706** to heat the conditioner **501**. Desiccant on the surface of the regenerator **501** absorbs water vapor and other contaminants such as  $\text{NO}_x$  and  $\text{SO}_x$  and other residual by products. The desiccant is transported to the water recovery system **2200** through optional filters **2603** that can capture some of the contaminants in the desiccant. Recovered water at **2608** can be drained off or can be diverted to a humidifier **1703** through lines **2609**, which can optionally be preheated by PVT modules **1704** or some other heat source. The cold loop for the condensation of water in the regenerator **2200** can be cooled by an external cooling coil **2607**, but can also be cooled by running water to the wavy plates **502** by the lines **2606**.

[**0159**] FIGS. **27A** and **27B** show three dimensional views of the desiccant system from FIG. **24A** set up for greenhouse heating. FIG. **27A** shows the enclosure **2701** containing the desiccant conditioner wavy plates **2405**. Fans **2701** can move the air through the desiccant conditioner. FIG. **27B** shows a rear view of the same system with some openings provided to illustrate the internal components. The regenerator plates **2202** receive hot water from the water heater **2402**. Heat exchanger **2404** separates the hot and cold desiccants. Condenser plates **2207** collect the water from the system.

[**0160**] FIG. **28** shows how the water generator **2200** can be used in a desalination system. Seawater **2803** is guided between a set of membranes **2801** that have concentrated desiccant **2804** on the opposite side. The desiccant functions as a draw fluid attracting water **2802** through the membrane into the desiccant, thereby diluting the desiccant. An optional set of PVT modules **2806** can preheat some of the desiccant. The diluted desiccant is now guided through the heat exchanger **2811** to the regenerator **2200**. A heating system **2807** heats a heat transfer fluid that is used in the regenerator wavy plates **2813**. The heat transfer fluid can also be heated by the PVT modules **2812**. The desiccant can also be heated by the PVT modules **2810**. An external cooling loop **2808** can be employed to cool the condenser plates **2814**. Pure water is recovered at point **2809**. The advantage if the described system is that it can operate at significantly lower power levels than desalination systems that use osmosis, since solution pump power can be kept very low.

[**0161**] Having thus described several illustrative embodiments, it is to be appreciated that various alterations, modifications, and improvements will readily occur to those skilled in the art. Such alterations, modifications, and improvements are intended to form a part of this disclosure, and are intended to be within the spirit and scope of this disclosure. While

some examples presented herein involve specific combinations of functions or structural elements, it should be understood that those functions and elements may be combined in other ways to accomplish the same or different objectives. In particular, acts, elements, and features discussed in connection with one embodiment are not intended to be excluded from similar or other roles in other embodiments. Additionally, elements and components described herein may be further divided into additional components or joined together to form fewer components for performing the same functions. Accordingly, the foregoing description and attached drawings are by way of example only, and are not intended to be limiting.

1. A liquid desiccant air conditioning system for dehumidifying an air stream, comprising:

- a desiccant conditioner for dehumidifying the air stream using a liquid desiccant;
- a desiccant regenerator for regenerating the liquid desiccant used in the conditioner, said desiccant regenerator including a heating system for heating liquid desiccant received from the conditioner, a first filter material through which air flows, and a mechanism for dispensing liquid desiccant heated by the heating system on the first filter material such that air flowing through the first filter material draws water vapor from the heated liquid desiccant, said liquid desiccant flowing from the regenerator to the mechanism for dispensing the liquid desiccant in the desiccant conditioner, wherein the heating system comprises a photovoltaic-thermal (PVT) module for heating a heat transfer fluid and a heat exchanger for transferring heat from the heat transfer fluid to the liquid desiccant, the PVT module also including one or more photovoltaic cells for generating electrical power used in operating the desiccant air conditioning system, wherein the desiccant regenerator further comprises an apparatus for condensing the water vapor from the air and collecting liquid water in a collection bath; and
- a heat exchanger for transferring heat from the liquid desiccant flowing from the regenerator to the conditioner to the liquid desiccant flowing from the conditioner to the regenerator.

2. The system of claim **1**, wherein the apparatus for condensing the water vapor comprises a second filter material in the desiccant regenerator through which air received from the first filter material flows, and a mechanism for dispensing water on the second filter material, said water being cooled by a heat exchanger transferring heat from the water to an air stream exiting the desiccant conditioner.

3. The system of claim **1**, further comprising a PVT module for heating liquid desiccant flowing from the conditioner to the regenerator.

4. The system of claim **1**, wherein the heating system further comprises a heater for heating the heat transfer fluid.

5. The system of claim **1**, wherein the air stream to be dehumidified is received from a greenhouse.

6. The system of claim **1**, wherein the mechanism for dispensing the liquid desiccant in the conditioner comprises one or more spray heads.

7. The system of claim **1**, wherein the filter media comprises a cellulosic cooling tower fill material.

8. The system of claim **1**, further comprising an additional desiccant conditioner for dehumidifying the air stream using the liquid desiccant, and wherein water is removed from the liquid desiccant by the regenerator.

**9.** The system of claim **1**, wherein the conditioner includes filter media through which the air stream flows and a mechanism for dispensing the liquid desiccant on the filter media, wherein as said air stream flows through the filter media, it is exposed to the liquid desiccant which absorbs water vapor from the air stream.

**10.** The system of claim **1**, wherein the conditioner comprises a plurality of structures arranged in a substantially vertical orientation, each structure having at least one surface across which the liquid desiccant can flow, wherein the air stream flows through or between the structures such that the liquid desiccant dehumidifies the air stream, each structure further includes a desiccant collector at a lower end of the at least one surface for collecting liquid desiccant that has flowed across the at least one surface of the structure.

**11.** The system of claim **10**, further comprising a cold source for cooling the liquid desiccant to be used in the conditioner.

**12.** The system of claim **10**, wherein each of the plurality of structures includes a passage through which heat transfer fluid can flow, and further comprising a cold source for cooling the heat transfer fluid.

**13.** The system of claim **12**, wherein the liquid desiccant and the heat transfer fluid flow in generally opposite directions in the conditioner.

**14.** The system of claim **10**, wherein the plurality of structures are secured within the conditioner in a way that permits the structures to freely expand or contract in a direction that is generally parallel to the thermal gradient to alleviate thermal-induced stress on the structures.

**15.** The system of claim **10**, further comprising a sheet of material positioned proximate to the at least one surface of each structure between the liquid desiccant and the air stream, said sheet of material guiding the liquid desiccant into a desiccant collector and permitting transfer of water vapor between the liquid desiccant and the air stream.

**16.** The system of claim **15**, wherein the surface tension of the liquid desiccant and properties of the sheet of material facilitate transfer of the liquid desiccant to a desiccant collector.

**17.** The system of claim **15**, wherein in each structure, a lower edge of the sheet of material is not fixedly connected to a lower portion of the structure to reduce pressure buildup of liquid desiccant.

**18.** The system of claim **15**, wherein the sheet of material comprises a membrane or a hydrophilic material.

**19.** The system of claim **15**, wherein the sheet of material comprises a hydrophobic micro-porous membrane.

**20.** The system of claim **15**, wherein the sheet of material comprises a layer of hydrophobic material and a layer of hydrophilic material between the hydrophobic material and the at least one surface of the structure.

**21.** The system of claim **15**, wherein each structure includes two opposite surfaces across which the liquid desiccant can flow, and wherein a sheet of material covers the liquid desiccant on each opposite surface, each sheet of material comprising an outer layer of a hydrophobic material and an inner layer of hydrophilic material, said inner layer facing one of the surfaces of the structure.

**22.** The system of claim **21**, wherein each structure includes an internal passage through which a heat transfer fluid can flow for transfer of heat between the heat transfer fluid and the liquid desiccant or the air stream.

**23.** The system of claim **15**, further comprising one or more vent holes in the sheet of material of each structure to enable liquid desiccant to freely flow between the sheet of material and the at least one surface of the structure and inhibit vacuum lock.

**24.** The system of claim **10**, wherein said plurality of structures comprises a plurality of plate assemblies arranged in a substantially vertical orientation and spaced apart to permit flow of the air stream between adjacent plate assemblies.

**25.** The system of claim **24**, wherein each plate assembly includes a convoluted plate.

**26.** The system of claim **10**, wherein the plurality of structures comprises a plurality of tubular members arranged in a substantially vertical orientation, at least some of which include an annular passage through which the liquid desiccant can flow and a central passage surrounded by the annular passage through which the air stream can flow.

**27.** The system of claim **10**, further comprising an apparatus for causing turbulence in the air stream flowing through or between the structures in the conditioner.

**28.** The system of claim **10**, wherein each structure comprises a thermally conductive plastic material.

**29.** The system of claim **1**, further comprising a tank connected to the conditioner for storing the liquid desiccant used in the conditioner, wherein the liquid desiccant varies in concentration along the height of the tank, and further comprising a mechanism for drawing liquid desiccant from the tank at different selected heights of the tank in order to obtain liquid desiccant having a given concentration.

**30.** The system of claim **1**, wherein the regenerator and the conditioner are physically separated to form a split air conditioning system.

\* \* \* \* \*