



US 20140324133A1

(19) **United States**

(12) **Patent Application Publication**
Deisseroth et al.

(10) **Pub. No.: US 2014/0324133 A1**

(43) **Pub. Date: Oct. 30, 2014**

(54) **MATERIALS AND APPROACHES FOR OPTICAL STIMULATION OF THE PERIPHERAL NERVOUS SYSTEM**

(60) Provisional application No. 61/079,035, filed on Jul. 8, 2008.

(71) Applicant: **The Board of Trustees of the Leland Stanford Junior University**, Palo Alto, CA (US)

Publication Classification

(51) **Int. Cl.**
A61N 5/06 (2006.01)

(72) Inventors: **Karl A. Deisseroth**, Stanford, CA (US); **Scott L. Delp**, Stanford, CA (US); **Michael E. Llewellyn**, Menlo Park, CA (US); **Christine A. McLeavey Payne**, Portola Valley, CA (US)

(52) **U.S. Cl.**
CPC *A61N 5/0622* (2013.01)
USPC **607/88**

(73) Assignee: **The Board of Trustees of the Leland Stanford Junior University**, Palo Alto, CA (US)

(57) **ABSTRACT**

(21) Appl. No.: **14/265,013**

A variety of methods, devices, systems and arrangements are implemented for stimulation of the peripheral nervous system. Consistent with one embodiment of the present invention, method is implemented in which light-responsive channels or pumps are engineered in a set of motor units that includes motor units of differing physical volumes. Optical stimuli are also provided to the light-responsive channels or pumps at an optical intensity that is a function of the size of motor units to be recruited. In certain implementations, the intensity of the optical stimuli is increased so as to recruit increasingly larger motor units.

(22) Filed: **Apr. 29, 2014**

Related U.S. Application Data

(62) Division of application No. 12/996,753, filed on Mar. 10, 2011, filed as application No. PCT/US2009/049936 on Jul. 8, 2009.

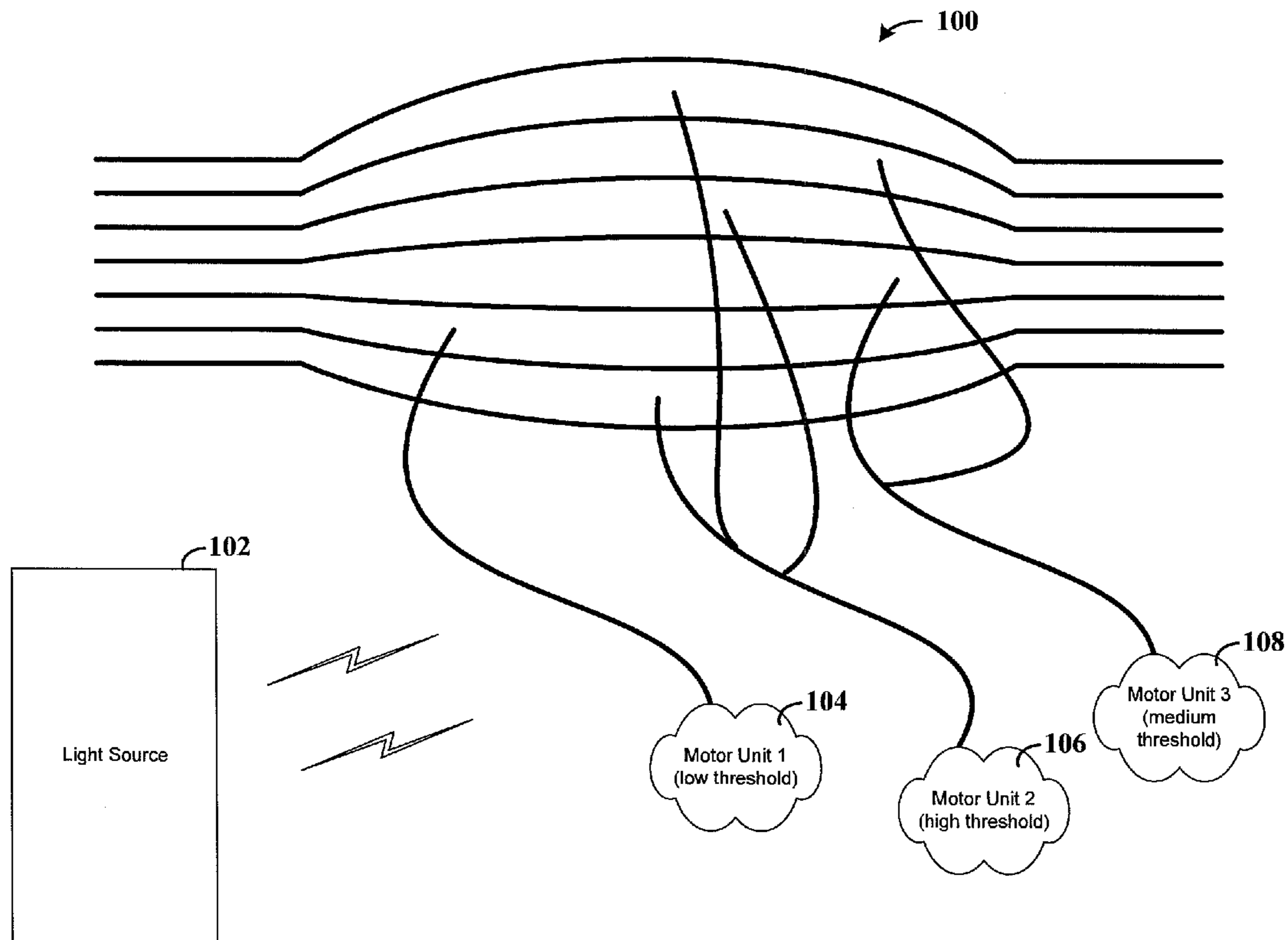

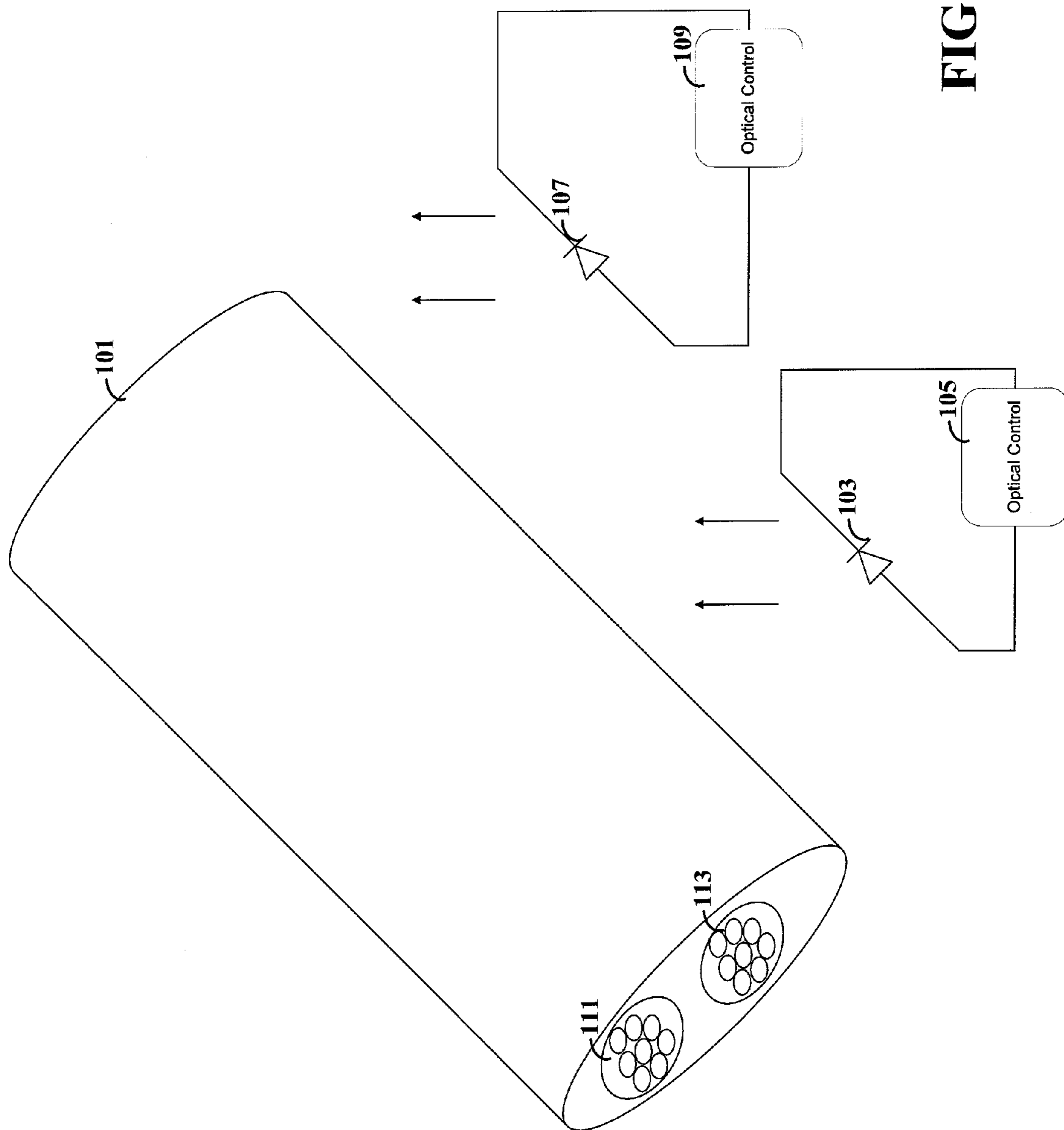

FIG. 1A

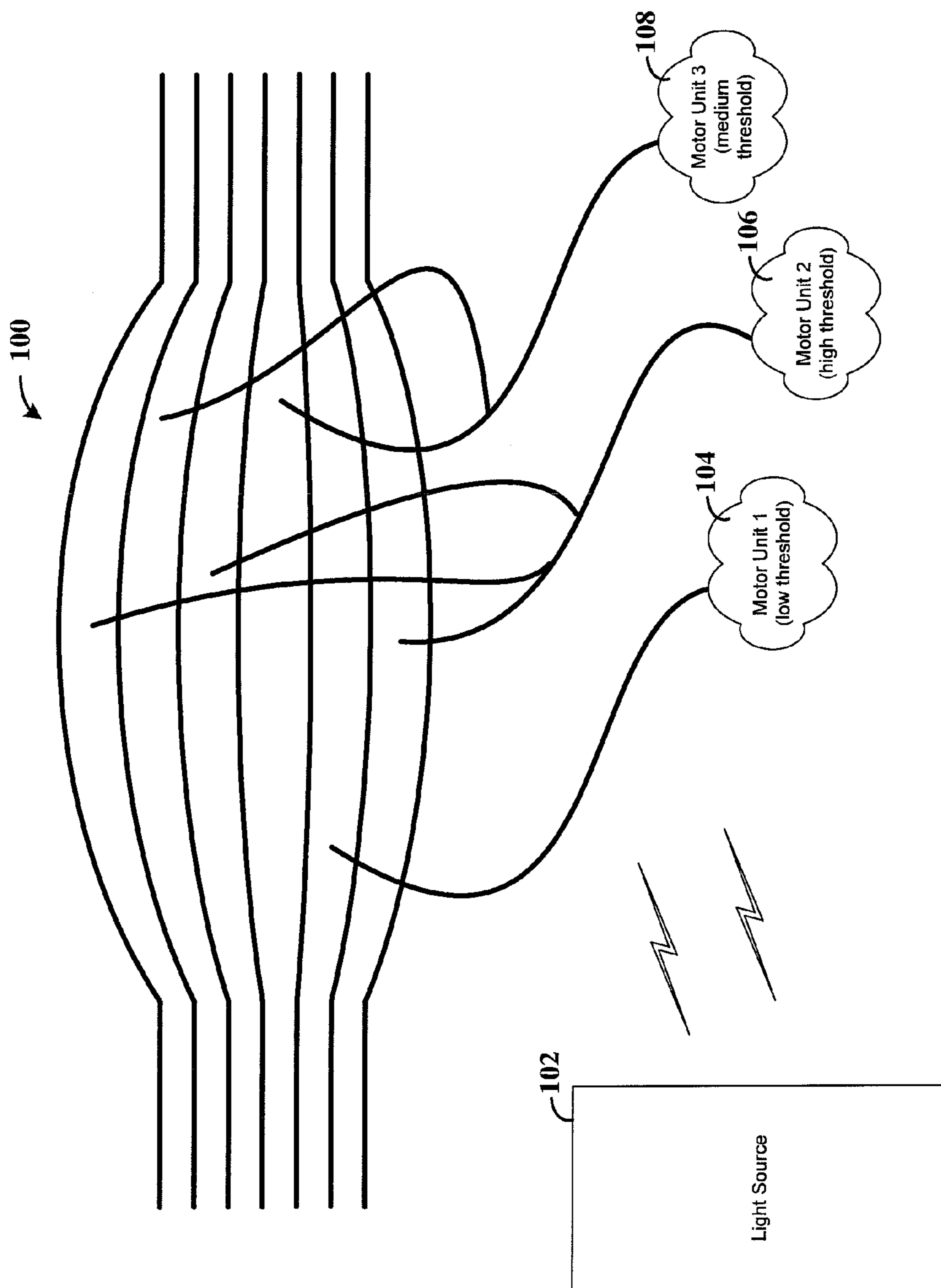

FIG. 1B

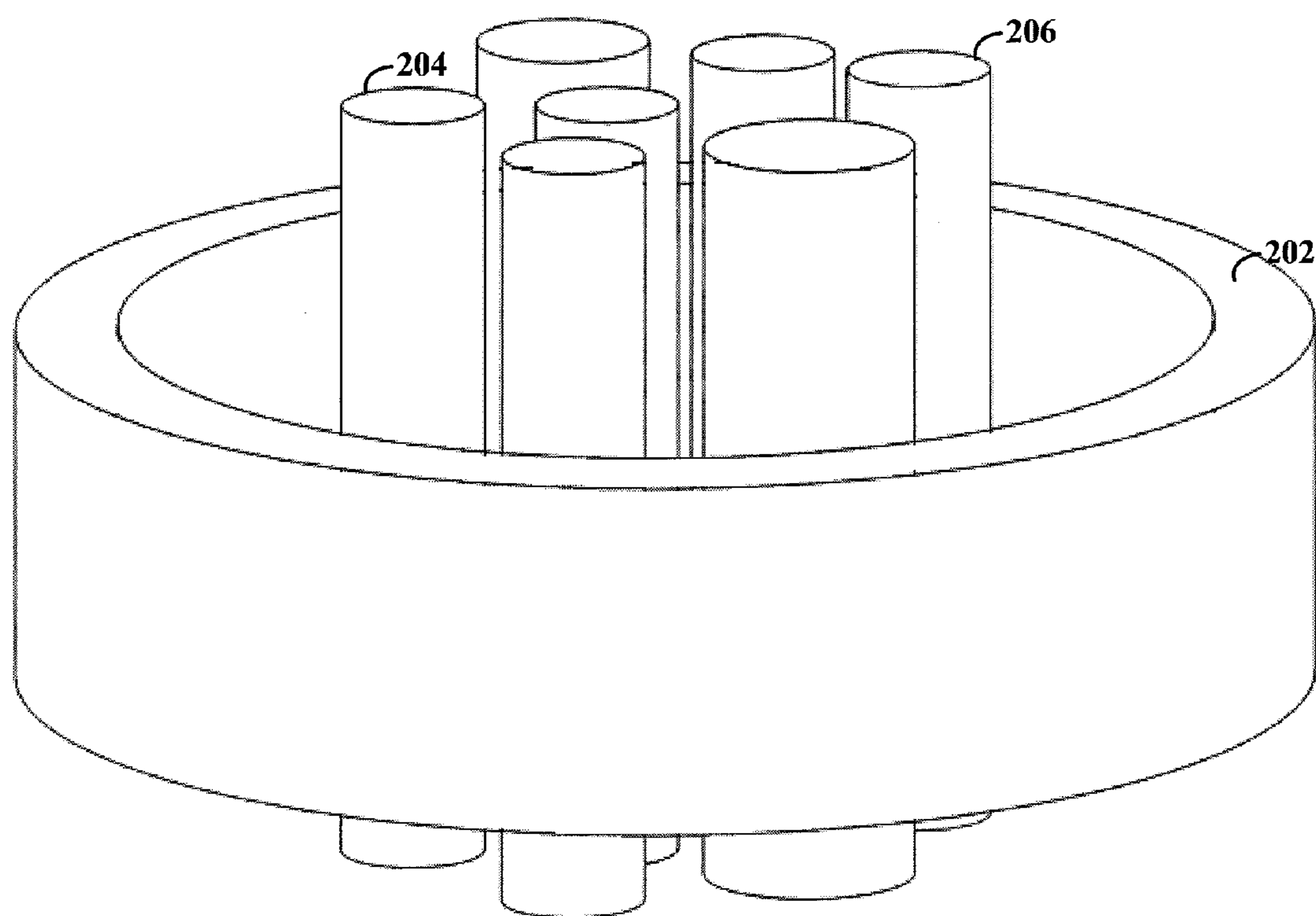

FIG. 2

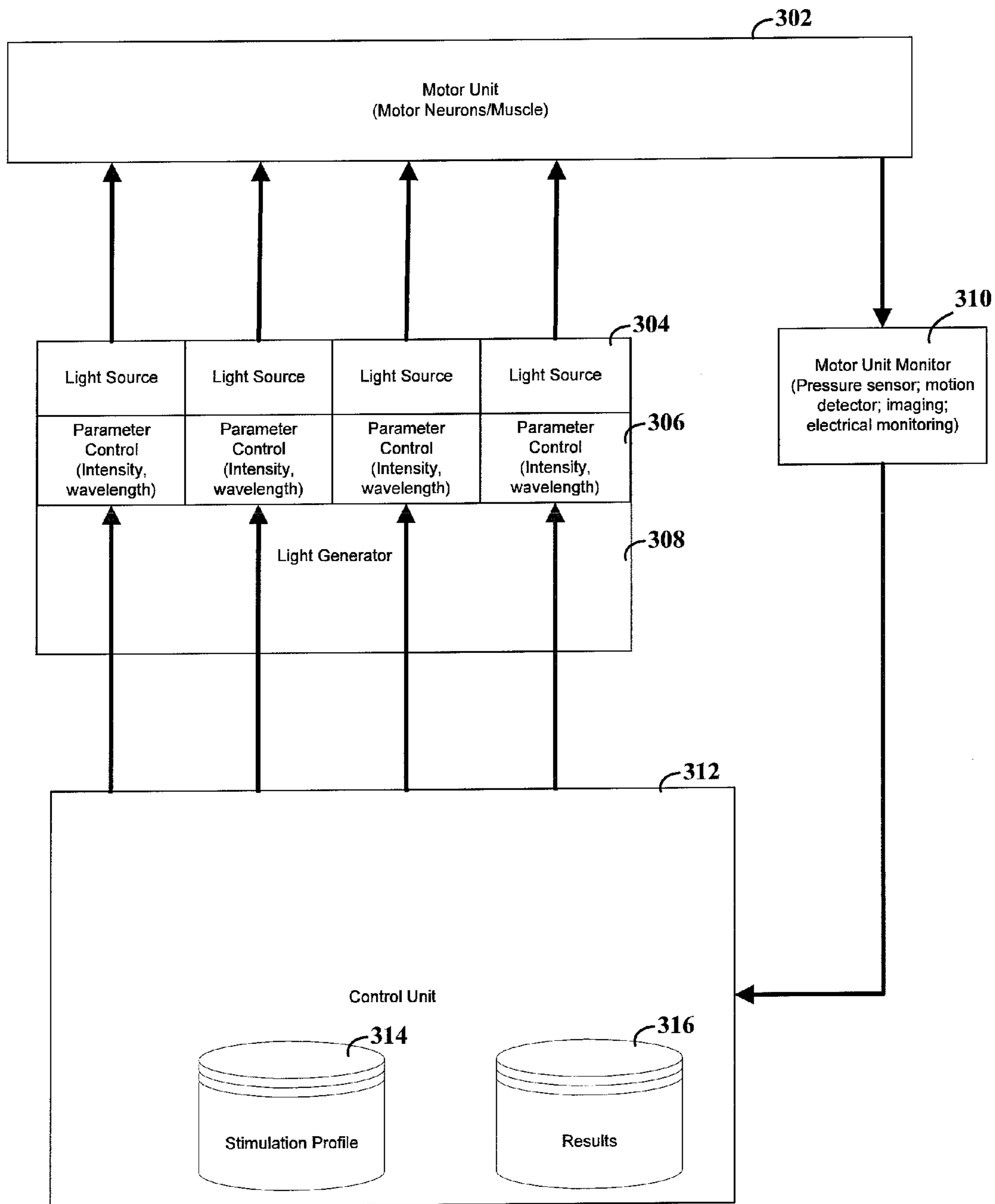

FIG. 3

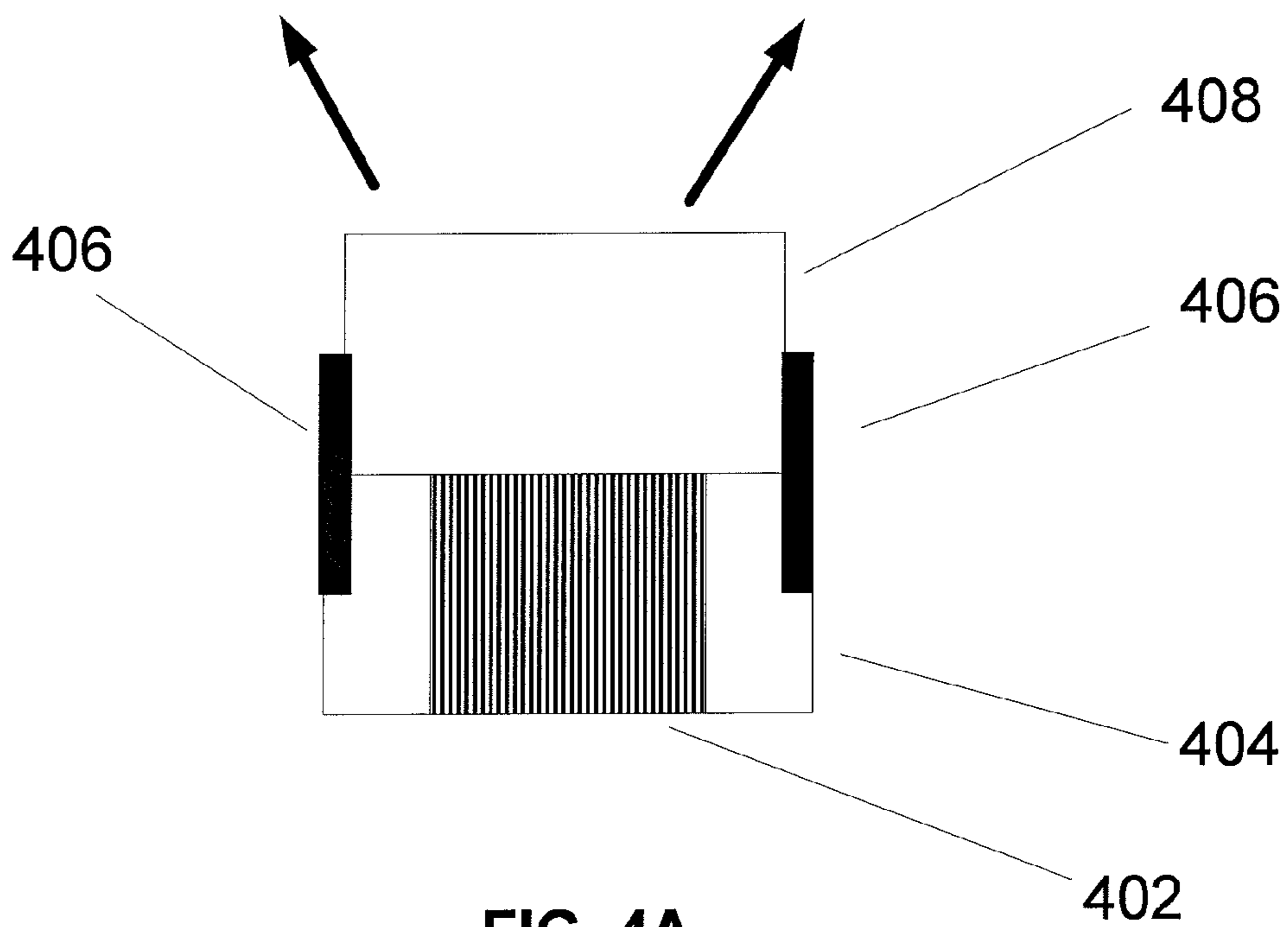

FIG. 4A

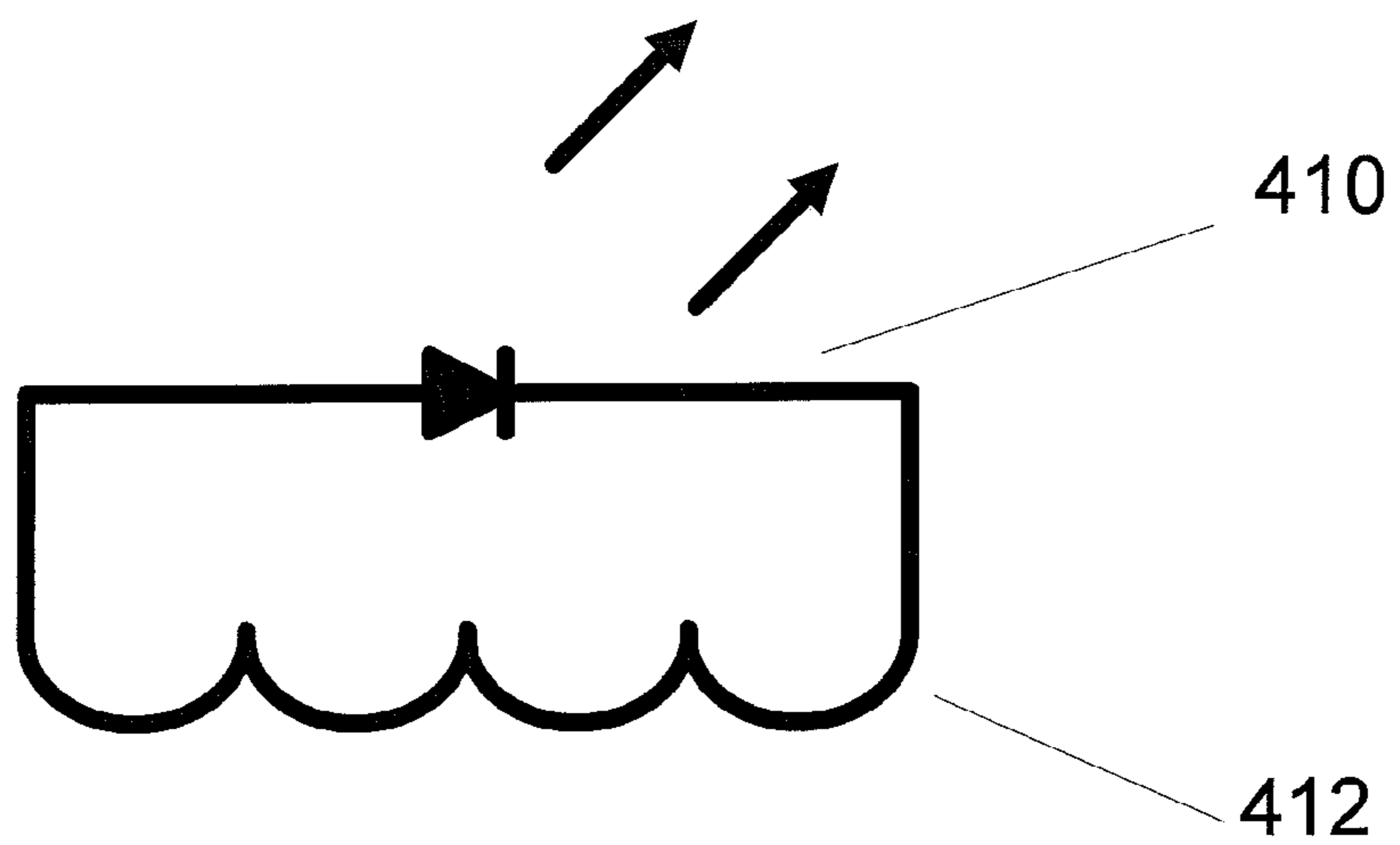

FIG. 4B

FIG. 5

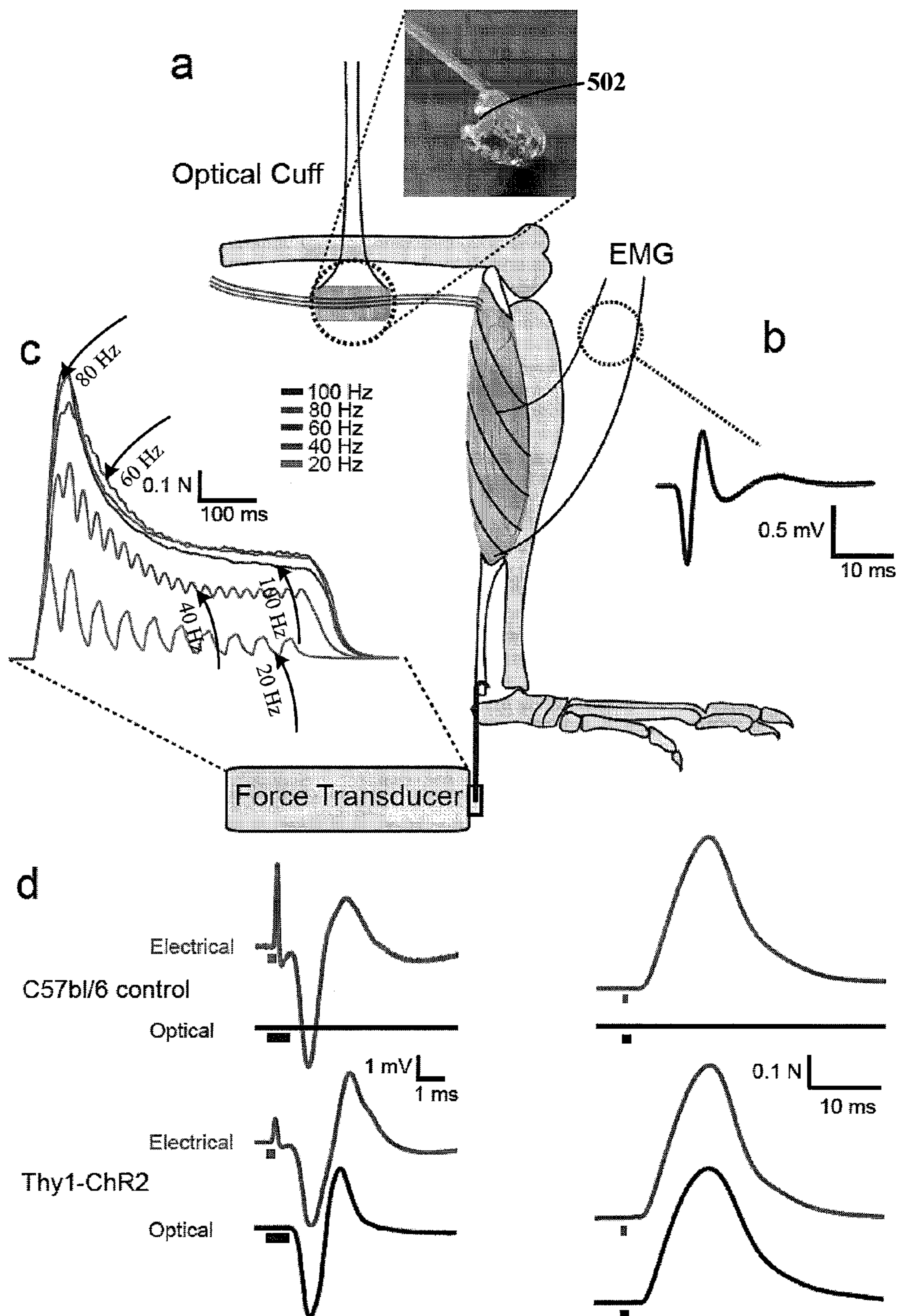
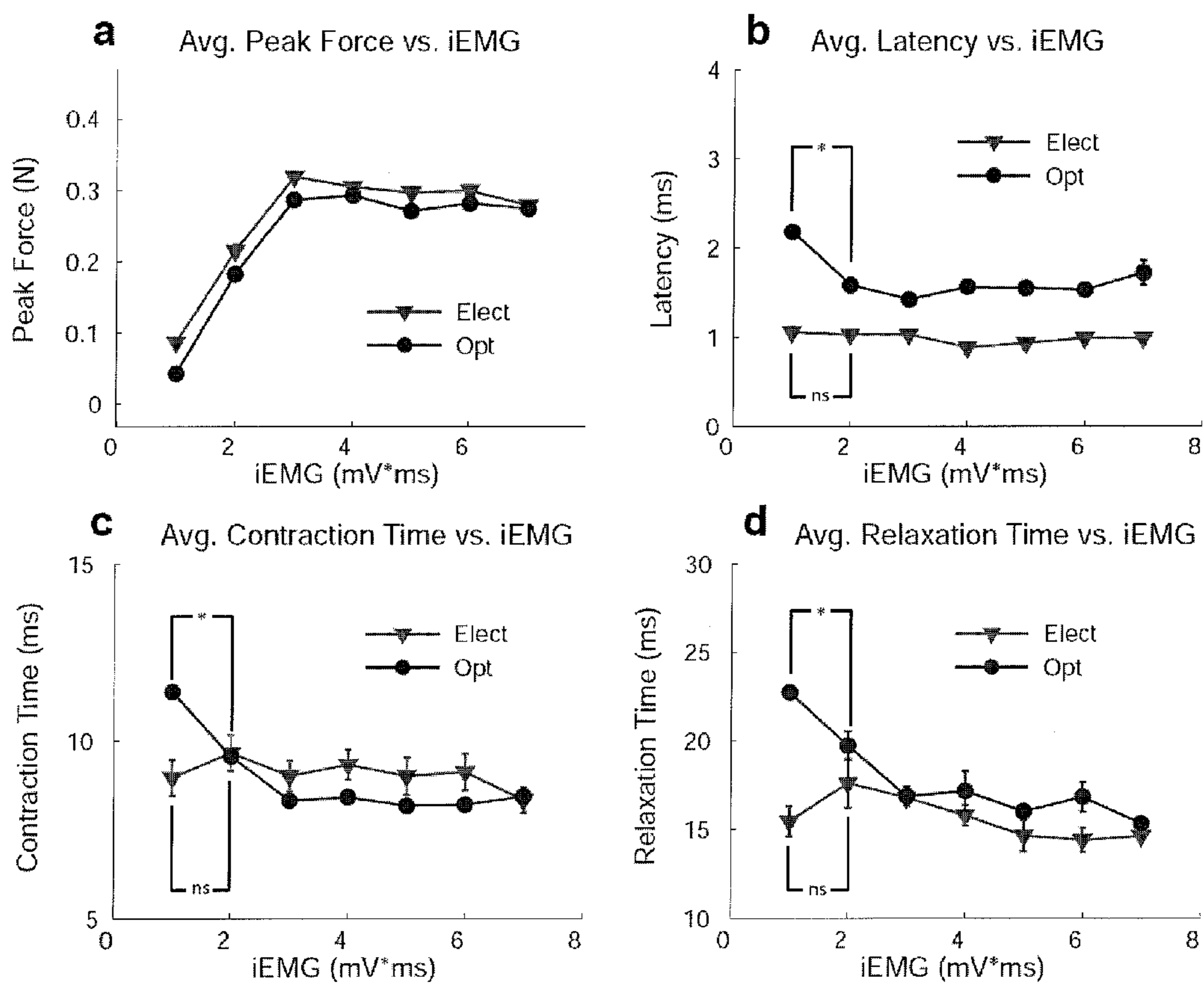

FIG. 6



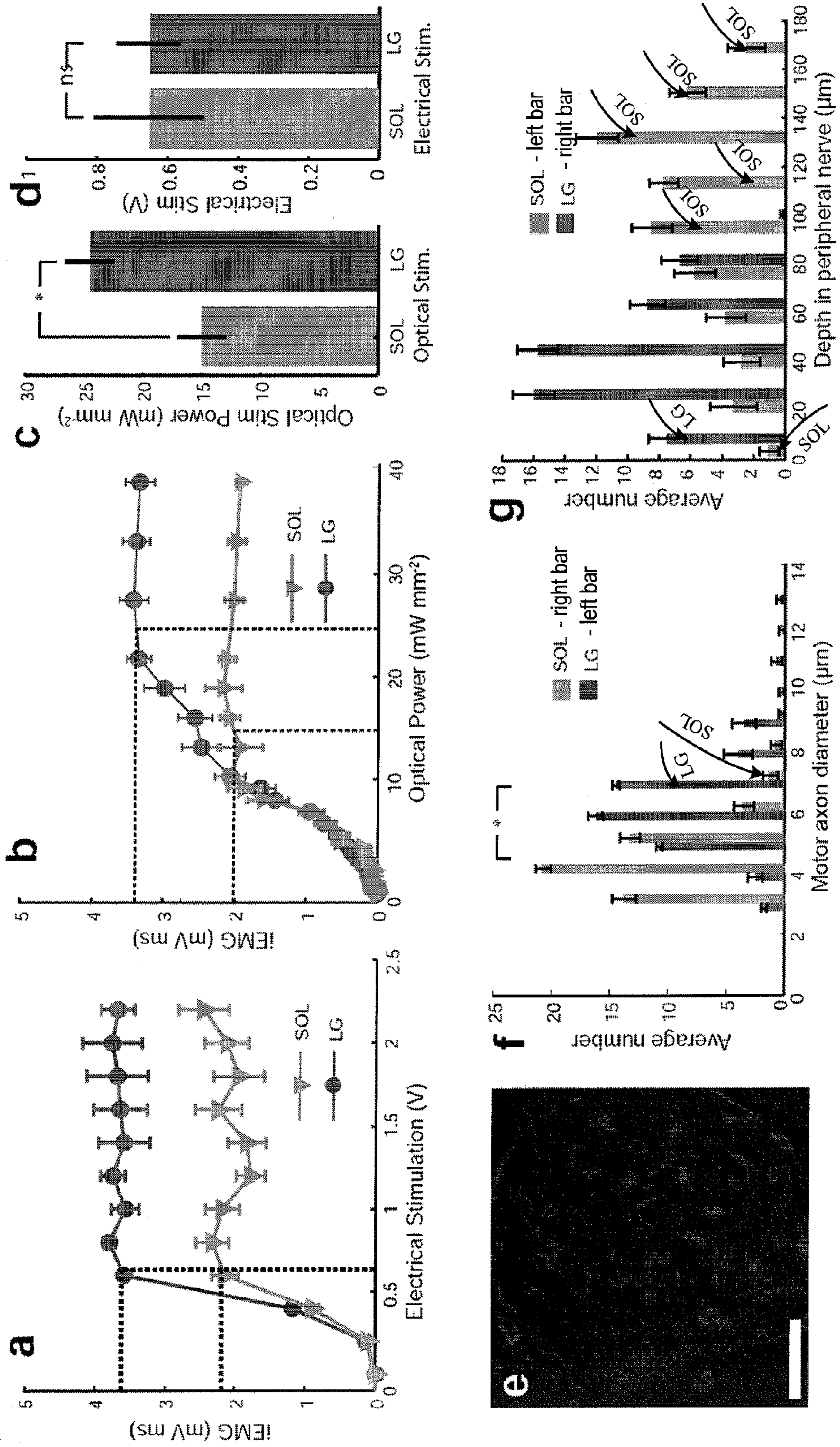

FIG. 7

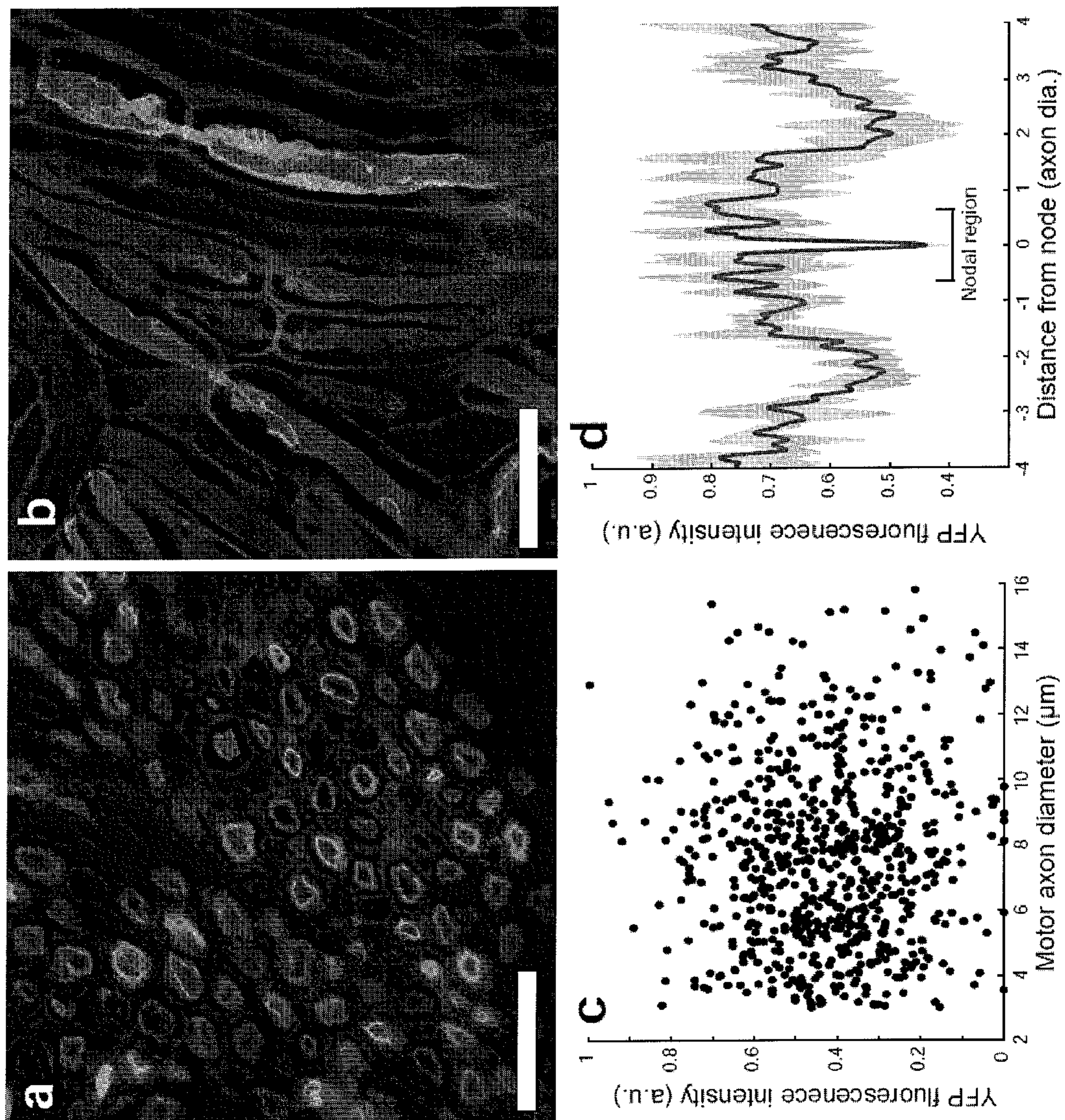
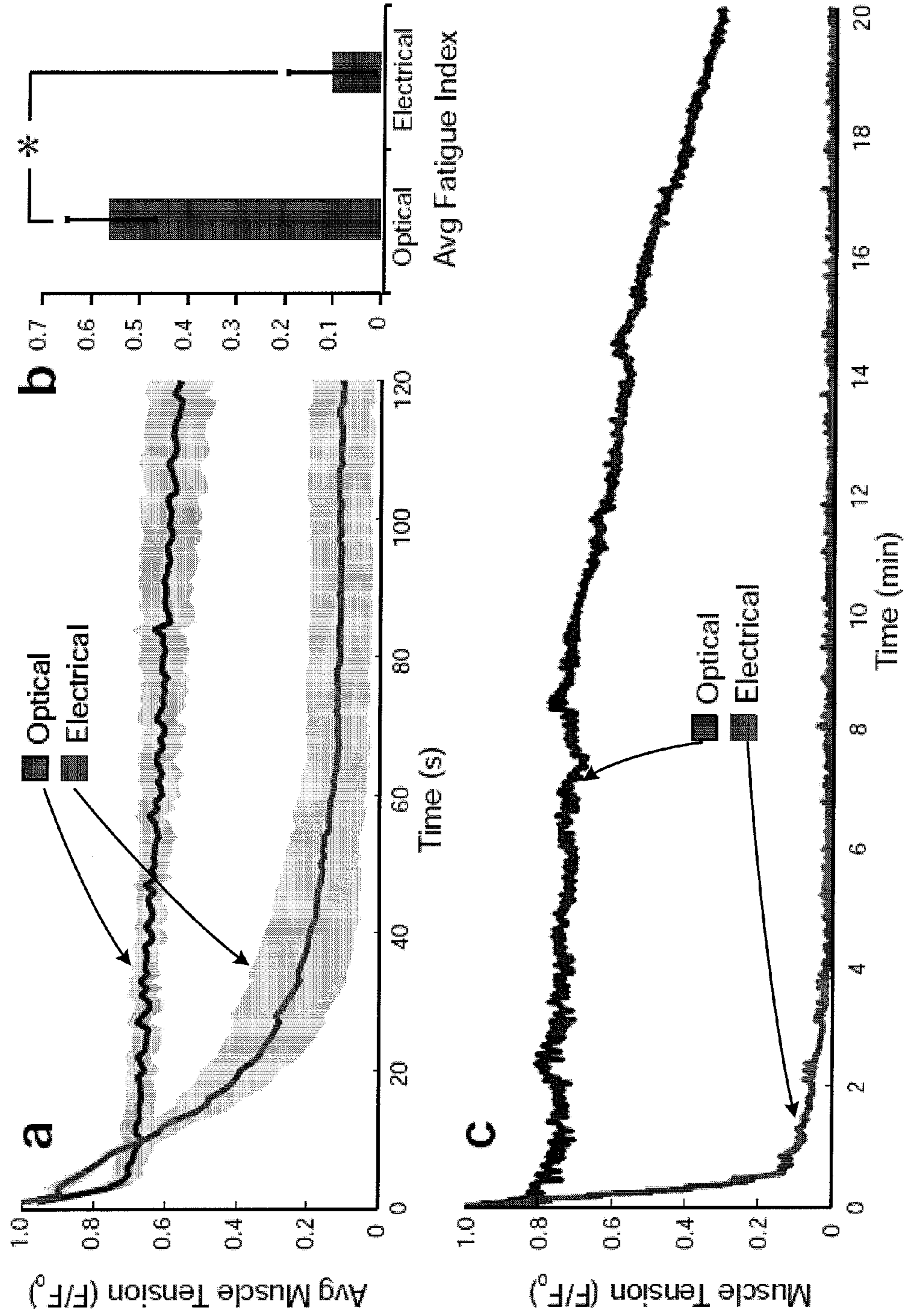

FIG. 8

FIG. 9



**MATERIALS AND APPROACHES FOR
OPTICAL STIMULATION OF THE
PERIPHERAL NERVOUS SYSTEM**

RELATED PATENT DOCUMENTS

[0001] This patent document claims the benefit, under 35 U.S.C. §119(e), of U.S. Provisional Patent Application Ser. No. 61/079,035 filed on Jul. 8, 2008, and entitled “Materials and Approaches for Optical Stimulation of the Peripheral Nervous System;” the underlying provisional application is fully incorporated herein by reference.

FIELD OF THE INVENTION

[0002] The present invention relates generally to stimulation of the peripheral nervous system, and more particularly to arrangements and approaches involving optical stimulus to affect the cells of the peripheral nervous system.

BACKGROUND

[0003] The peripheral nervous system extends from the brain and spinal cord to various portions of the body. Two of the main functions of the peripheral nervous system are muscle control and sensory feedback. Peripheral nerves carry signals between the various portions of the body and the central nervous system using electrical signals.

[0004] A typical muscle is composed of many thousands of fibers, which contain the contractile machinery of the muscle. Rather than individually controlling each fiber, a single motor neuron can control groups of fibers that form motor units. Motor units vary in size from 100 to several hundred fibers, and also vary in composition of muscle fiber type. Small motor units are typically composed of slow type muscle fibers that are fatigue-resistant, while larger motor units are generally composed of fast type fibers that are easily fatigable and medium sized motor units consist of a mixture of slow and fast fiber types. Motor units are recruited, or turned on, in a specific order that generally begins with the smallest group and progresses to the largest group. In this way, the smaller, fatigue-resistant motor units are used more often, and thus allow for fine force control for longer periods of use. The larger motor units, with larger capacity for generating force, are conserved for brief periods of time when they are most needed, e.g., during a reflex, emergency or other strenuous activities. The size of a motor neuron is correlated to the size of the motor unit that the motor neuron controls, so that a large motor neuron will control a large motor unit.

[0005] The normal physiologic recruitment order refers to a typical (healthy) order of motor neuron recruitment, where the size of the motor axons and the motor neuron cell bodies define the sequence of recruitment. For a given synaptic input of current, a smaller motor neuron will be recruited before a larger motor neuron, thus determining the order, small to large.

[0006] External electrical stimulation of motor neurons has been attempted. One such attempt stimulates the axon of a motor neuron. This, however, results in a recruitment order that is reversed when compared to the normal physiologic order (the larger motor units are recruited before smaller ones). The implication of this recruitment reversal is that large, fatigable motor units are recruited first, resulting in the loss of fine motor control and sustained motor function. Thus, fatigue has become a limiting factor in limb reanimation projects that have attempted to use electrical stimulation.

[0007] The other type main function of the peripheral nervous system, sensory feedback, is responsible for pain, touch, appetite and a variety of other aspects. When problems with arise with sensory feedback mechanisms, the results are often drastic and sometimes even life threatening. For example, chronic pain is a serious health issue that affects many individuals, seriously degrading their quality of life and often having long-term psychological impact. Another issue addressable through sensory feedback relates to appetite suppression.

[0008] Aspects of the present invention relate to control and/or stimulation of peripheral nervous system using optical stimulus.

SUMMARY

[0009] Aspects of the claimed invention relate generally to stimulation of the peripheral nervous system, and more particularly to arrangements and approaches involving optical stimulus to affect the cells of the peripheral nervous system.

[0010] Consistent with an embodiment of the present invention, a method is implemented in which light-responsive channels or pumps are engineered in a set of motor units that includes motor neurons of differing physical volumes. Optical stimuli are also provided to the light-responsive channels or pumps at an optical intensity that is a function of the size of motor units to be recruited. In certain implementations, the intensity of the optical stimuli is increased so as to recruit motor units having increasingly larger motor neurons.

[0011] Embodiments of the present invention relate to a method where light-responsive channels or pumps are engineered in a set of peripheral afferent nerves. Optical stimuli are provided to the light-responsive channels or pumps to mitigate pain. Specific implementations relate to the expression of NpHR in the peripheral afferent nerves while providing optical stimuli to modify pain recognition in the central nervous system.

[0012] An embodiment of the present invention relates to a method in which light-responsive channels or pumps are engineered in a set of vagal fibers associated with the gastrointestinal system. Optical stimuli are provided to the light-responsive channels or pumps.

[0013] Consistent with other embodiments of the present invention, light-responsive channels or pumps are engineered in a set of stem cells. The set of stem cells are implanted at a target location, and optical stimuli are provided to the light-responsive channels or pumps to cause activation of muscle at the target location. Specific embodiments relate to the use of skeletal muscle stem cells to repopulate muscles or implanting the set of stem cells for myocardial repair.

[0014] Other embodiments of the present invention relate to a device, kit or system having delivery component for expression of light-responsive channels or pumps in the peripheral nervous system and having an optical component for providing optical stimulus to the light-responsive channels or pumps in the peripheral nervous system. In a particular implementation, the delivery component includes a nucleic acid molecule capable of transporting the light-responsive channels or pumps to which it has been operatively linked.

[0015] The above summary of the present invention is not intended to describe each illustrated embodiment or every implementation of the present invention.

BRIEF DESCRIPTION OF THE DRAWINGS

[0016] The invention may be more completely understood in consideration of the detailed description of various embodiments of the invention that follows in connection with the accompanying drawings, in which:

[0017] FIG. 1A depicts a peripheral nerve stimulated by optical stimulus devices, consistent with an embodiment of the present invention;

[0018] FIG. 1B shows muscle fibers controlled by a set of light-responsive motor neurons, according to an example embodiment of the present invention;

[0019] FIG. 2 shows a light stimulation device for placement around peripheral nerves, according to an example embodiment of the present invention;

[0020] FIG. 3 shows a system for stimulating motor neurons, according to an example embodiment of the present invention;

[0021] FIG. 4A shows a block diagram of an implantable device, according to an example embodiment of the present invention;

[0022] FIG. 4B shows a circuit diagram corresponding to the block diagram of FIG. 4A, according to an example embodiment of the present invention;

[0023] FIG. 5A shows a stimulation cuff for placement around a peripheral nerve, consistent with an embodiment of the present invention;

[0024] FIG. 5B shows the muscles electrical response (M-wave) as measured by fine wire electrodes placed in the muscle belly and near the Achilles tendon, consistent with an embodiment of the present invention;

[0025] FIG. 5C shows the contractile force output as measured by a force transducer attached to the Achilles tendon, consistent with an embodiment of the present invention;

[0026] FIG. 5D depicts electromyography (EMG) and force traces from twitches elicited by optical and electrical stimulations in both Thy1-ChR2 animals and control C57bl/6 animals, consistent with an embodiment of the present invention;

[0027] FIG. 6A shows peak force during a single twitch vs. rectified integrated EMG for both electrical and optical stimulations, consistent with an embodiment of the present invention;

[0028] FIG. 6B depicts average latency measured from initiation of stimuli to detection of EMG, consistent with an embodiment of the present invention;

[0029] FIG. 6C shows the average contraction time measured from 10% of peak force to peak force, consistent with an embodiment of the present invention;

[0030] FIG. 6D depicts average relaxation time measured from peak force to 10% of peak force, consistent with an embodiment of the present invention;

[0031] FIG. 7A shows rectified-integrated EMG (iEMG) vs. estimated optical intensity at the surface of the sciatic nerve for soleus (SOL) and lateral gastrocnemius (LG), consistent with an embodiment of the present invention;

[0032] FIG. 7B shows rectified-integrated EMG vs. electrical stimulation voltage applied to the sciatic nerve, consistent with an embodiment of the present invention;

[0033] FIG. 7C shows optical intensity required to achieve maximum iEMG in SOL and LG, consistent with an embodiment of the present invention;

[0034] FIG. 7D shows electrical stimulation required to achieve 95% of maximum iEMG in SOL and LG, consistent with an embodiment of the present invention;

[0035] FIG. 7E shows an example cross-section of the sciatic nerve where retrograde dye was injected into the LG only, scale bar=100 μ consistent with an embodiment of the present invention;

[0036] FIG. 7F shows distribution of motor axon diameters for SOL and LG found in cross-section of the sciatic nerve, consistent with an embodiment of the present invention;

[0037] FIG. 7G shows depth of motor axons for SOL and LG found in cross-section of the sciatic nerve, consistent with an embodiment of the present invention;

[0038] FIG. 8A depicts a confocal image of sciatic nerve in cross-section, consistent with an embodiment of the present invention;

[0039] FIG. 8B depicts a confocal image of sciatic nerve in a longitudinal section with the same staining as in FIG. 8A, illustrating several nodes of Ranvier (gaps formed between myelin sheaths of cells), scale bar is 50 μ m, consistent with an embodiment of the present invention;

[0040] FIG. 8C shows YFP fluorescence intensity versus motor axon size in cross-section (n=4), consistent with an embodiment of the present invention;

[0041] FIG. 8D shows the average fluorescence intensity parallel to the long axis of sampled axons, where the origin indicates the center of the node of Ranvier (n=15, shaded region is standard deviation (s.d.)), consistent with an embodiment of the present invention;

[0042] FIG. 9A shows the average tetanic tension over two minutes in muscle being stimulated with 250 ms trains at 1 Hz using electrical and optical stimulation (n=7, shaded region is standard error (s.e.)), consistent with an embodiment of the present invention;

[0043] FIG. 9B shows the average fatigue index for electrical and optical stimulation, measured as decline in tetanic tension over two minutes (n=7, error bars are s.e., * indicates p<0.01), consistent with an embodiment of the present invention; and

[0044] FIG. 9C shows an example of tetanic tension taken from a single mouse using both optical and electrical stimulation in contralateral hindlimbs over 20 minutes, consistent with an embodiment of the present invention.

[0045] While the invention is amenable to various modifications and alternative forms, examples thereof have been shown by way of example in the drawings and will be described in detail. It should be understood, however, that the intention is not to limit the invention to the particular embodiments shown and/or described. On the contrary, the intention is to cover all modifications, equivalents, and alternatives falling within the spirit and scope of the invention.

DETAILED DESCRIPTION

[0046] The present invention is believed to be applicable to a variety of different types of processes, devices and arrangements relating to stimulation of peripheral nerves. While the present invention is not necessarily so limited, various aspects of the invention may be appreciated through a discussion of examples using this context.

[0047] According to one embodiment of the present invention, peripheral nerves are optically stimulated to activate light-responsive molecules therein. The light responsive molecules can inhibit and/or facilitate electrical signaling (e.g., action potentials) within the peripheral nerves. For instance, many peripheral nerve bundles include mixed types of nerves (e.g., motor and sensory). One or both of the nerve types can

be affected by optical stimulation. In specific instances, each of the nerve types can be selectively stimulated.

[0048] As used herein, stimulation can include either activation or deactivation of electrical signaling in the nerves. For instance, nerve cells are stimulated by adjusting the membrane voltage level of the nerve cell to facilitate action potentials or to inhibit action potentials. Moreover, for various embodiments of the present invention, the temporal precision of various light responsive molecules allow for control of individual action potentials, whether the control is via facilitation or inhibition.

[0049] According to an embodiment of the present invention, a cuff-shaped optical delivery device allows for stimulation of both types of nerves, or for selective stimulation. These and other implementations can be used for treatment of various conditions, such as muscle spasticity, among other things.

[0050] According to an example embodiment of the present invention, motor neurons are optically stimulated. The optical stimulus activates ion channels and/or pumps in the motor neurons to excite or inhibit neural activation and thereby affect contractions and/or relaxation of muscle tissue. Properties of light stimulus can be modified to allow for variations in the effect on the muscle tissue.

[0051] A specific embodiment of the present invention uses variation of the intensity of the optical stimulus to control activation of motor neurons engineered with light responsive ion channels or pumps. It is believed that different motor neurons will respond differently to light of varying intensities. The differing responses can be particularly useful for selectively producing coarse and fine contractions. Other properties of light that can be used to control responsiveness of motor neurons include, but are not limited to, wavelength, spatial location and temporal properties (e.g., pulse duration or pulse separation).

[0052] Motor neurons use electrical signaling to transmit control signals between portions of the nervous system and muscle fibers. The electrical signals take the form of electrical pulses or action potentials. An action potential is a voltage pulse that travels along the membrane of the motor neuron. An action potential is generated when the membrane voltage reaches a threshold voltage level. An action potential of the motor neuron results in the release of chemicals (neurotransmitters). These chemicals cause the muscle fiber to contract.

[0053] One embodiment of the present invention uses light to activate light-responsive cation channels in the motor neuron. Light of sufficient intensity and wavelength activates the cation channels, which induces a current in the motor neuron. The induced current moves the membrane voltage toward the threshold voltage necessary to produce an action potential. If sufficient current is induced, an action potential is generated and the muscle fibers of the corresponding motor unit are activated.

[0054] One embodiment of the present invention involves introducing light-activated cation channels in one or more motor neurons. One mechanism for introducing the cation channels involves the use of vectors, such as lentiviruses, retroviruses, adenoviruses and phages. The vectors are introduced to the motor neurons and result in expression of the gene for the light-activated cation channels.

[0055] Surprisingly and consistent with embodiments of the present invention, it has been discovered that optical stimulation can be used to recruit motor units in a largely normal physiologic order. The number of light-activated

channels opened is proportional to the intensity of the light that is applied. Although not bounded by theory, it is believed that the density of light-activated channels (e.g., using vectors) is relatively uniform between different sized motor neurons. As the size of a motor axon increases, the membrane area increases by the power of two, while the motor axon volume increases by the power of three. The number of light-activated channels relates more directly to the membrane area as opposed to the motor axon volume. Therefore, as a motor axon increases in size, the volume increases at a rate such that larger motor axons have fewer light-activated channels per volume. This implies that for a given light intensity, motor neurons of smaller motor units have a faster change in voltage due to the light-activated channels. Accordingly, smaller motor neurons exhibit larger changes in membrane potential than larger motor neurons. Thus with increasing light intensity, the size of motor units recruited also increases, matching the normal physiologic order.

[0056] Embodiments of the present invention are implemented with knowledge of these unexpected results. For instance, the optical stimulus profile (e.g., optical intensity, optical frequency or spatial location) can be set as a function of the size of motor unit/neuron to be recruited. A lookup-table or an algorithm can be used to associate a desired muscle response with a particular optical profile. According to one such implementation, the optical stimulus profile can be set according to a muscle fatigue factor. Due to the activation of smaller motor neurons before larger motor neurons, measurements of the muscle fatigue can be used to determine the point at which motor neurons of increasingly larger size are recruited. The experimental results presented herein provide examples of fatigue-based determinations that are consistent with embodiments of the present invention.

[0057] Another factor that can be used includes the contractile response (strength and/or speed) of recruited motor units. The contractile response can be correlated to the size of the motor units/neurons that were recruited under a specific optical stimulus profile. The optical stimulus is then determined as a function of the desired contractile response of the muscle. The contractile response can be measured by a variety of different mechanism. Non-limiting examples include force and/or speed measurements caused by muscle contraction or monitoring of muscle activation (e.g., electromyography (EMG) measurements).

[0058] Such factors are but a few of the possible mechanisms for determining an optical stimulus profile. Other factors can include, for example, the location, size and/or type of muscle tissue under stimulus. Moreover, different species may require different stimulus profiles and/or different stimulus devices. The age, physical size and fitness of the patient can be used as factors in determining an optical stimulus profile.

[0059] Various other determinable factors are contemplated for determining the optical stimulus profile, many of which are facilitated by knowledge of the orderly recruitment of motor units that can be provided by embodiments of the present invention. Accordingly, while the invention is not limited to orderly recruitment of motor units, various embodiments are facilitated by this aspect.

[0060] Turning now to the figures, FIG. 1A depicts a peripheral nerve stimulated by optical stimulus devices, consistent with an embodiment of the present invention. Nerve trunk **101** includes nerve bundles **111** and **113**. The nerve bundles **111** and **113** are engineered to include light respon-

sive channels/pumps. Optical stimulus devices **103** and **107** provide optical stimulus to the engineered light-responsive channels/pumps. Although not limited thereto, optical stimulus devices **103** and **107** are depicted as light-emitting diodes (LEDs) controlled by optical control circuits **105** and **109**, respectively.

[0061] In one implementation, a single optical stimulus device **103/107** can be used. In other implementations, multiple optical stimulus devices **103/107** are possible. The optical stimulus devices can operate at the same wavelength of light or at different wavelengths of light. When operating at the same wavelength of light, the use of multiple optical stimulus devices can increase the intensity of the provided optical stimulus, increase the area of optical stimulus and/or provide spatially controllable optical stimulus. For instance, the physical location of the optical stimulus devices can be used as a factor in the stimulation of the light-responsive channels/pumps. Due to relative position of the devices, morphology of the nerve trunk or other factors, the devices can provide different responsiveness of the nerves and associated functions.

[0062] Optical control circuits **105** and **109** can also be implemented so that individual control of the optical stimulus devices is possible. This can be particularly useful for implementations where the optical stimulus devices operate at different wavelengths. Different types of light responsive channels/pumps can be designed to have a different wavelength for the optimal responsiveness. In a particular embodiment of the present invention, the differences in the wavelengths are sufficient to allow for activation of one type of light responsive channel/pump without activating the other type of light responsive channel/pump. In this manner, a first type (e.g., ChR2) of channel/pump can be used to facilitate activation (action potentials) in a nerve and a second type (e.g., NpHR) of channel/pump can be used to inhibit activation (action potentials) in a nerve. Other possibilities include the targeting of the first type of channel/pump to a first type of cell (e.g., slow twitch motor unit) and the second type of channel/pump to a second type of cell (e.g., fast twitch motor unit).

[0063] These examples show the wide variety of applications and possible applications for embodiments of the present invention. A number of such embodiments, including those discussed in connection with the various figures, are directed to control of muscle fibers through optical stimulation of motor neurons. Other embodiments, some of which are expressly discussed herein, are also contemplated. For instance, peripheral nerves also provide sensory responses (e.g., pain, touch or appetite). A number of disorders are associated with abnormal sensory responses. Accordingly, various embodiments relate to treatment or characterization of various sensory-related disorders.

[0064] FIG. 1B shows muscle fibers controlled by a set of light-responsive motor neurons, according to an example embodiment of the present invention. Muscle fibers **100** are responsive to motor units **104**, **106** and **108**. Each motor unit responds to a different motor neuron. Motor unit **104** has a motor neuron with a relatively low threshold, meaning that the motor neuron is responsive to a lower amount of stimulus. Motor unit **106** has a motor neuron with a relatively high threshold, and motor unit **108** has a motor neuron with threshold between the other two motor neurons. Under normal physiologic recruitment, this would allow for the activation of

motor unit **104** without activating motor units **106** or **108** and for the activation of motor unit **108** without activation motor unit **106**.

[0065] In a specific implementation, the motor neurons include proteins/molecules that function as light-activated ion channels or pumps. Light source **102** provides light to the light-activated ion channels or pumps. If the light is sufficient to activate the light-responsive molecules, ion flow across the membrane modifies the membrane voltage of the motor neurons. As the intensity of the light increases, the percentage of light-responsive molecules that are activated also increases. Thus, light intensity can be used to activate the smaller motor units without activation of the larger motor units.

[0066] It should be noted that factors other than light intensity can play a role in the activation of the light-responsive molecules. For example, the wavelength of light can also have an effect on activation of motor units. For example, increasing the intensity of light at a specific wavelength may have little or no effect when the wavelength is outside of an effective absorption band (i.e., wavelengths that the molecules respond to) for light-responsive molecules. In another example, shifting the wavelength of the light relative to the effective absorption band can change the percentage of light-responsive molecules that respond without modifying intensity of the light. Other examples involve the duration of the light and/or the spatial location of the delivered light relative to the motor neurons.

[0067] In one implementation, the application of the optical stimulus is responsive to a sensed neural activation. For instance, a damaged portion of a nerve can be effectively bypassed by sensing neural activation signals and providing responsive optical stimuli at a point beyond the damaged portion of the nerve. In one implementation, the sensed neural activation can be neural activation within the nerve, but prior to the damaged portion. In another implementation, the sensed neural activation could be from an otherwise unassociated portion of the nervous system. For this second type of implementation, the patient can retrain the neural pathways to control the damaged nerve using the previously unassociated portion of the nervous system. Another example of sensed activation includes sensing muscle activation more directly (e.g., using an EMG). In response to sensed activation, optical stimulus can be provided to recruit additional motor units. In this manner, the muscle activation can be increased by the application of an optical stimulus profile.

[0068] FIG. 2 shows a light stimulation device for placement around peripheral nerves, according to an example embodiment of the present invention. Light stimulation device **202** surrounds motor neurons **204** and **206**. Motor neurons **204** and **206** can be of different sizes, allowing for selective activation thereof. In one implementation, stimulation device **202** can vary the intensity of the generated light as desired so as to allow for selective activation of certain ones of the motor neurons.

[0069] Embodiments of the present invention include implementations of light stimulation device **202** that do not surround motor neurons **204** and **206**. For example, light stimulation device **202** can be implemented using a U-shaped cuff that is designed to be placed proximate to the motor neurons. Other shapes are possible, including point light sources, such as an optical fiber.

[0070] In certain implementations light stimulation device **202** is attached to an arm (not shown) that can be used to guide the light stimulation device **202** near the motor neurons **204**

and 206. If desired, the arm can be subsequently removed. Alternatively, the arm can be left in place and used the help fix the position of light stimulation device 202, provide adjustment of the position of light stimulation device 202 and/or provide power/control signals to light stimulation device 202.

[0071] FIG. 3 shows a system for stimulating motor neurons, according to an example embodiment of the present invention. Motor units (motor neurons and muscle fibers) 302 include light responsive ion channels/pumps. Light generator 308 includes one or more light sources 304 that stimulate the channels/pumps within the motor units. Parameter controls 306 allow for control of light sources 304 by modifying the light properties. The modification of parameters can be implemented so as to allow for activation of some motor units without activating others. For example, the intensity of the light can be set at a level that activates some motor units and not others. In another instance, the wavelength of light can be changed, thereby achieving much the same effect as modifying the intensity of the light. Other possibilities include activating only some of the light sources 304, or using different light parameters for certain light sources 304.

[0072] Motor unit monitor 310 provides feedback on the activation of the motor units. The feedback can be implemented using a number of different measurements. For example, motion associated with the muscle can be monitored to determine the strength of the contraction using a pressure sensor, speed of the movement using image capture and/or the preciseness of the movement (e.g., smooth or jerky). In some instances it may also be possible to measure the electrical responsiveness of the motor units. As the stimulus is optical and not electrical, the electrical signals represent the results of the stimulus without separating the (optical) stimulus signals from the (electrical) results thereof. These and other results can be stored in a results database 316.

[0073] Control unit 312 can be used to generate stimulus profiles that are used to control the light generator 308. These profiles can be stored within a stimulation profile database 314. In one implementation, a sequence of profiles are implemented and correlated to the results stored in results database 316. The desired muscle response can then be implemented by providing a stimulation profile that is correlated to the desired result.

[0074] According to a specific embodiment of the present invention, both inhibitory and excitation molecules are implemented to provide control of the motor units. In certain instances this can provide further delineation between activation of different motor units by, for example, enabling both the inhibitory and excitation molecules. This can effectively reduce the likelihood of a motor neuron action potential (relative to enabling the excitation molecules without enabling the inhibitory molecules). In certain instances, stimulation for inhibition and excitation can be provided at different spatial locations. This can allow for each of the inhibition and excitation stimulus to more strongly affect different motor neurons, respectively.

[0075] In one embodiment of the present invention, an implantable device includes a control portion that responds to magnetic fields. This control portion can be implemented as an electrical wire, resistive element or other responsive element. In such an embodiment, the intensity, duration and frequency of light generated would be controlled by the current generated from an introduced magnetic field. This can be particularly useful for creating inexpensive, long lasting and

small devices. An example of such an embodiment is discussed further in connection with FIG. 4A and FIG. 4B.

[0076] In another embodiment of the present invention, the control portion can be implemented as a more complex circuit. For instance the control circuit may include and otherwise implement different rectifier circuits, batteries, pulse timings, comparator circuits and the like. In a particular example, the control circuit includes an integrated circuit (IC) produced using complementary metal-oxide-semiconductor (CMOS) or other processes. Integrated circuit technology allows for the use of a large number of circuit elements in a very small area, and thus, a relatively complex control circuit can be implemented for some applications.

[0077] In a particular embodiment of the present invention, the light generating portion is a blue LED, such as LEDs in 0603 or 0805 package sizes. A particular example is a blue surface mount LED having part number SML0805, available from LEDtronics, Inc (Torrance, Calif.).

[0078] FIG. 4A shows a block diagram of an implantable device, according to an example embodiment of the present invention. FIG. 4A shows an inductor comprising coils 402 and core 404 connected to LED 408 using conductive paths shown by 406. FIG. 4B shows a circuit diagram corresponding to the block diagram of FIG. 4A. Inductor 412 is connected in parallel to LED 410. Thus, current and voltage generated by changing a magnetic field seen at inductor 412 causes LED 410 to produce light. The frequency and strength of the changing magnetic field can be varied to produce the desired amount and periodicity of light from LED 410.

[0079] Examples of light stimulation devices are taught by International Application No. PCT/US08/50628, entitled System for Optical Stimulation of Target Cells, to Schneider et al., and filed Jan. 9, 2008. The patent document teaches a variety of devices and delivery devices for use with light-responsive molecules. As such, the document is hereby incorporated by reference in its entirety.

[0080] There are a number of suitable light-responsive molecules that can be used to modify nerve cells so that the cells are optically responsive. One class of molecules facilitates action potentials in the nerve cells by inducing ionic current that moves the membrane voltage toward the voltage threshold of the cell. In one embodiment of such a molecule, the light-responsive molecule is one of the proteins ChR2, Chop2, ChR2-310, or Chop2-310. In another embodiment, the light-responsive molecule is a 7-transmembrane protein. In another embodiment, the light-responsive molecule is a single-component protein. In yet another embodiment, the light-responsive molecule covalently binds retinal. For further details on light responsive molecules reference can be made to the aforementioned System for Optical Stimulation of Target Cells, to The Board of Trustees of the Leland Stanford Junior University, which is fully incorporated herein by reference.

[0081] Another class of molecules discourages action potentials in the nerve cells by inducing ionic current that moves the membrane voltage away from the voltage threshold of the cell. In one embodiment, the light responsive molecule is an archaeal light-driven chloride pump (NpHR) from *Natronomonas pharaonis*. For further details on such light responsive molecules, reference can be made to Zhang et al., (2007) *Multimodal Fast Optical Interrogation of Neural Circuitry*, Nature 2007 Apr. 5; 446(7136):617-9, which is fully incorporated herein by reference. These and other molecules can be used alone or in conjunction with one another.

[0082] A few specific examples of light responsive molecules, their use and stimulation devices and techniques (e.g., ChR2 or NpHR) are provided in U.S. patent application Ser. No. 11/459,636, entitled Light-Activated Cation Channel and Uses Thereof, to Boyden et al., and filed Jul. 24, 2006; in International Application No. PCT/US2008/050628, entitled System for Optical Stimulation of Target Cells, to The Board of Trustees of the Leland Stanford Junior University and filed on Jan. 9, 2008; and also in U.S. patent application Ser. No. 12/041,628, entitled Systems, Methods and Compositions for Optical Stimulation of Target Cells, to Zhang et al., and filed on Mar. 3, 2008. These documents teach a number of different light responsive molecules (including, but not limited to, specific sequence listings) as well as variants thereof. These documents include numerous discussions of example molecules as well as delivery and stimulation techniques. As such, these documents are hereby incorporated by reference in their entirety.

[0083] A particular embodiment uses a two-part approach: expression of ChR2 (or NpHR in other cases) in the neurons of interest, followed by implantation of a light source to illuminate the nerve at the specified frequency. ChR2 expression can be achieved through “projection targeting”, whereby opsin vectors are injected not at the site of eventual illumination, but at a distant site where the cell bodies of the target neurons lie. Alternately, target muscles can be infused with a retrograde virus; in this approach, one does not need to know cell type-specific promoters, and only the axons of the targeted cells are optically modulated even though they may be intermixed with other cell types in the nerve. Unlike other optically-responsive channels that have been developed, although ChR2 and NpHR require an all-trans-retinal (ATR) chromophore as a cofactor, retinoids naturally present in mammalian cells are sufficient.

[0084] A specific implementation uses an LED-based nerve cuff, where several micro LEDs are embedded in a solid, optically transparent cuff, and surgically placed around the desired nerve. This cuff provides high intensity light source for stimulating the desired nerve. A specific example light intensity for ChR2 stimulation is >1.0 mW/mm² light power density. Embodiments of the present invention allow for alternatives to LEDs, such as solid state laser diodes, or some future technology. Considerations for selection of the light source can include efficiency concerns in terms of size, expense, heating, and battery life.

[0085] The following description provides details relating to an experimental mouse model for such therapies, as well as evidence that optical stimulation recruits muscle fibers in a normal (healthy) physiologic order, thereby avoiding the problem faced by electrical stimulation. Human nerves are generally larger and the technology is therefore scaled accordingly, however, the same principles of operation can be used.

[0086] Muscle parameters were measured in vivo to characterize motor unit recruitment. Motor unit recruitment is often characterized by stimulating individual motor axons from the peripheral nerve at the ventral root. In small animals such as mice, however, this technique is impractical.

[0087] FIG. 5A shows a stimulation cuff (e.g., synthesized optical light source) for placement around a peripheral nerve, consistent with an embodiment of the present invention. The stimulation cuff 502 is depicted as having a curved portion designed to at least partially surround the peripheral nerve, however, other embodiments allow for variations including,

but not limited to, a cuff that predominantly surrounds a peripheral nerve and point light sources. In the experiment, both electrical and optical stimuli were provided to an anesthetized Thy1-ChR2 mouse by way of such a cuff. The experiment was carried out using an optical cuff (and compared to an electrical cuff) around the sciatic nerve of an adult Thy1-ChR2 or control (C57bl/6) mouse. Stimuli were provided by the cuff to evoke an electrical and contractile response of the muscle.

[0088] FIG. 5B shows the muscles electrical response (M-wave) as measured by fine wire electrodes placed in the muscle belly and near the Achilles tendon, consistent with an embodiment of the present invention. The waveform depicts an electromyography (EMG) plot of typical twitch from optical stimulation.

[0089] FIG. 5C shows the contractile force output as measured by a force transducer attached to the Achilles tendon, consistent with an embodiment of the present invention. In a mouse, the medial gastrocnemius (MG), the lateral gastrocnemius (LG) and the soleus (SOL) have free tendons that attach to the distal end of the Achilles tendon. To measure muscle forces of an individual muscle, the free tendons of the muscles not being measured are detached. The detached Achilles tendon was fixed to a force transducer to measure muscle contractions. The force traces show typical titanic contractions at various frequencies using optical stimulation.

[0090] FIG. 5D depicts EMG and force traces from twitches elicited by optical and electrical stimulations in both Thy1-ChR2 animals and control C57bl/6 animals, consistent with an embodiment of the present invention. These traces show that typical twitch response generated by optical stimulation from the MG does not have a significantly different shape than twitches evoked by electrical stimulation in either Thy1-ChR2 or control animals. The exception to this observation is the absence of a stimulation artifact in the EMG response just prior to the initiation of depolarization under optical stimulation, but seen in all cases of electrical stimulation. There was no response to optical stimulation in control animals, which implies that optical stimulation occurs by photostimulation of the ChR2 channels and not by heat or other electrical means.

[0091] To compare electrical and optical stimulation intensities the rectified integrated EMG (iEMG) was used over the time of non-zero activity in each trial. To verify that measurement of iEMG represents a common response of the muscle under both electrical and optical stimulation and also to verify that optical stimulation can elicit contractile forces comparable to electrical stimulation, the average peak force during a twitch was compared to the iEMG response. FIG. 6A shows peak force during a single twitch vs. rectified integrated EMG for both electrical and optical stimulations, consistent with an embodiment of the present invention. For a given iEMG, both optical and electrical stimulations produce similar trends, but the peak twitch forces were on average 15.4% lower using optical stimulation. Average peak twitch forces using electrical stimulation (0.32 ± 0.05 N) were significantly higher ($p < 0.01$) than average twitch forces with optical stimulation (0.29 ± 0.01 N), possibly indicating that most but not all motor neurons are stimulated under optical stimulation. Twitch forces produced by electrical and optical stimulation are consistent with previous measurements.

[0092] Measurement of motor axon conduction latency is the most common method used to estimate motor unit recruitment. Smaller axons have slower conduction speeds, and

therefore have longer latencies for a given distance. FIG. 6B depicts average latency measured from initiation of stimuli to detection of EMG, consistent with an embodiment of the present invention. Latency represents the time difference between the initiation of the stimuli and the depolarization measured on EMG (M-wave). Latencies measured under optical stimulation for all intensities (2.18 ± 0.02 - 1.72 ± 0.13 ms) were significantly longer than those under electrical stimulation (1.15 ± 0.05 - 0.99 ± 0.01 ms, $p < 0.01$ in all cases). This difference is possibly due to lower cation conductance of ChR2 channels, which delays the formation of an action potential. The conduction velocity was estimated (32.2 - 40.4 m s⁻¹), due to significant uncertainty in the path length of the axon from the site of stimulation to site of measurement and found to be consistent with expected values. At the lowest levels of activity, the drop in latency from 1 mV ms to 2 mV ms under optical stimulation was significant ($p < 0.01$) while the difference under electrical stimulation was not ($p = 0.11$). This implies that smaller axons are recruited preferentially at the lowest levels of optical stimulation but not under electrical stimulation.

[0093] Other measures of motor unit recruitment, such as the contraction and relaxation times, were found to suggest orderly recruitment with optical stimulation. FIG. 6C shows the average contraction time measured from 10% of peak force to peak force, consistent with an embodiment of the present invention. Under optical stimulation (11.1 ± 0.08 ms), the contraction time was significantly longer at the lowest levels of muscle activity than electrical stimulation (8.79 ± 1.01 ms, $p < 0.01$). While at the highest levels of muscle activity, contraction time under optical and electrical stimulation was not found to be significantly different (8.34 ± 0.07 ms, $p = 0.60$).

[0094] FIG. 6D depicts average relaxation time measured from peak force to 10% of peak force, consistent with an embodiment of the present invention. This relaxation time was significantly longer at the lowest level of muscle activity with optical stimulation (21.73 ± 0.39 ms) than electrical stimulation (17.46 ± 0.68 ms, $p < 0.01$), whereas relaxation time at the highest levels of muscle activity were not significantly different between the different types of stimulation (14.54 ± 0.09 ms, $p = 0.10$). The measurements of contraction and relaxation time, which are consistent with other *in vitro* data, both imply that at the lowest levels of muscle activity, optical stimulation preferentially recruits slower motor units than electrical stimulation.

[0095] To further examine differential motor unit recruitment, the recruitment of two different muscles, soleus (SOL) and lateral gastrocnemius (LG), were compared. FIG. 7A shows rectified-integrated EMG (iEMG) vs. estimated optical intensity at surface of the sciatic nerve for soleus (SOL) and lateral gastrocnemius (LG), consistent with an embodiment of the present invention. Whereas FIG. 7B shows rectified-integrated EMG vs. electrical stimulation voltage applied to the sciatic nerve, consistent with an embodiment of the present invention.

[0096] SOL contains $58 \pm 2\%$ slow oxidative (SO) fibers and 0% fast glycolytic (FG) fibers, while LG has $69 \pm 13\%$ FG fibers and $1 \pm 3\%$ SO fibers. It has been reported that smaller motor units tend to have higher compositions of SO fibers, and therefore, it was expected that SOL motor units would be recruited prior to the faster motor units of LG, an observation that has been reported in physiological recruitment studies. FIG. 7C shows optical intensity required to achieve maxi-

mum iEMG in SOL and LG, consistent with an embodiment of the present invention. Under optical stimulation SOL (14.9 ± 1.9 mW mm⁻²) reaches 95% peak activity at a significantly lower optical intensity than LG (FIG. 7C, 24.4 ± 1.9 mW mm⁻², $p < 0.01$). At the lower levels of optical stimulation, LG and SOL have similar levels of activity. This observation can be attributed to the possibility that LG contains small motor units composed of fast muscle fibers.

[0097] FIG. 7D shows electrical stimulation required to achieve 95% of maximum iEMG in SOL and LG, consistent with an embodiment of the present invention. The electrical stimulation used to evoke 95% of peak activity in SOL (0.64 ± 0.15 V) and LG (0.64 ± 0.09 V) was not significantly different (FIG. 7D, $p < 0.01$). These findings suggest that slower muscle fibers are preferentially recruited by optical stimulation before faster fibers; however, the order of motor unit recruitment would be more certain given knowledge of the size distribution of the motor axons innervating each muscle.

[0098] To analyze axon size distribution, and to determine if there was bias in the location of the axons innervating each muscle within the cross-section of the peripheral nerve, retrograde dye (Fast Blue) was intramuscularly injected into the muscles of interest to backfill only the axons innervating the muscle in which it was injected. FIG. 7E shows an example cross-section of the sciatic nerve where retrograde dye was injected into the LG only, scale bar=100 μ m, consistent with an embodiment of the present invention.

[0099] FIG. 7F shows distribution of motor axon diameters for SOL and LG found in cross-section of the sciatic nerve, consistent with an embodiment of the present invention. FIG. 7G shows depth of motor axons for SOL and LG found in cross-section of the sciatic nerve, consistent with an embodiment of the present invention.

[0100] In cross-sections of the sciatic nerve (FIG. 7E) SOL and LG do not contain significantly different numbers of motor axons (FIG. 7F, 53.5 ± 4.9 , 55 ± 3.7 , $p = 0.71$). However, the average motor axon innervating LG had a significantly larger Feret's diameter than those innervating SOL (6.7 ± 0.16 μ m, 4.5 ± 0.17 μ m, $p < 0.01$). No bias was observed as to the location of either set of axons within the peripheral nerve so that one set would be exposed to significantly higher light intensities than another. These observations support the premise that small motor units are preferentially recruited under optical stimulation, and that the observed difference in optical intensity required for peak muscle activity in SOL and LG is not influenced by either number of axons or position of those axons in the peripheral nerve.

[0101] To determine the location of the ChR2 channels within the motor axons and whether there were any differences in expression levels in relation to the size of the motor axons, cross-sections of the sciatic nerve were made both parallel and perpendicular to the long axis of the motor axons. FIG. 8A depicts a confocal image of sciatic nerve in cross-section, consistent with an embodiment of the present invention. The first channel is due to anti-laminin labeling basal lamina of the peripheral nerve. The second channel is due to YFP fluorescence expressed natively in the transgenic neurons, scale bar is 50 μ m. FIG. 8B depicts a confocal image of sciatic nerve in a longitudinal section with the same staining as in FIG. 8A, illustrating several nodes of Ranvier, scale bar is 50 μ m. The ChR2 channels are labeled with yellow fluorescent protein (YFP), so the average relative YFP fluores-

cence intensity of axons was compared to the diameter of those axons using confocal microscopy.

[0102] FIG. 8C shows YFP fluorescence intensity versus motor axon size in cross-section ($n=4$), consistent with an embodiment of the present invention. No correlation was found between axon size and fluorescent intensity in the transverse sections (FIG. 8C, $R^2=0.0021$, $p=0.88$). Additionally it was possible to locate nodes of Ranvier within the cross-sections (FIG. 8B).

[0103] FIG. 8D shows the average fluorescence intensity parallel to the long axis of sampled axons, where the origin indicates the center of the node of Ranvier ($n=15$, shaded region is s.d.), consistent with an embodiment of the present invention. The fluorescence, and presumably the ChR2 channel density, varies along the axolemma. Fluorescence intensity at center of the nodal region is at a minimum, while fluorescence intensity in the peri-nodal region is at a maximum. It is known from immuno-localization studies that the center of the nodal region contains high concentrations of Na^+ channels, which is likely the cause of the lower fluorescent signal in this region. Additionally, the nodal and internodal regional morphology appears normal, giving no indication for abnormal behavior of the transgenic motor neurons.

[0104] The ability to preferentially recruit slower motor units with optical stimulation has potentially enormous functional significance. Functional Electrical Stimulation (FES) systems have been developed to serve as neuro-prosthetics for patients with paralysis, but have not been adopted widely because of early onset fatigue possibly due to reverse recruitment by electrical stimulation. To test whether optical stimulation of muscle elicits less fatigue than electrical stimulation, measurements were taken of tetanic tension generated by the plantar flexor group of Thy1-ChR2 mice using both stimulation types. FIG. 9A shows the average tetanic tension over two minutes in muscle being stimulated with 250 ms trains at 1 Hz using electrical and optical stimulation ($n=7$, shaded region is s.e.), consistent with an embodiment of the present invention. FIG. 9B shows the average fatigue index for electrical and optical stimulation, measured as decline in tetanic tension over two minutes ($n=7$, error bars are s.e., * indicates $p<0.01$), consistent with an embodiment of the present invention. Using stimulation intensities in each modality that elicited $2\times$ body weight for each unfatigued mouse, 1 Hz stimulation trains were used for 2 minutes, with each train lasting 250 ms. The average fatigue index, measured as the average tetanic tension of the last train divided by the average tetanic tension in the first train, declined significantly lower in trials using electrical stimulation (0.11 ± 0.09), than those using optical stimulation (0.56 ± 0.09 , $p<0.01$). Additionally, when this fatigue protocol is extended to 20 minutes in an individual mouse using contralateral hindlimbs, electrical stimulation diminishes tetanic tension to $\sim 0\%$ after just 4 minutes, while optical stimulation continues to elicit 31.6% of its initial tension after the entire 20 minute trial. FIG. 9C shows an example of tetanic tension taken from a single mouse using both optical and electrical stimulation in contralateral hindlimbs over 20 minutes, consistent with an embodiment of the present invention.

[0105] Physiological measurements were taken according to the following methodology. Normal appearing, 9-12 week old Thy1-ChR2 or C57bl/6 control mice were anesthetized and the hindlimb was shaved and fixed in a frame. The Achilles tendon was freed by cuffing the distal end of the calcaneus to a force transducer (Aurora Scientific, 300CLR) by

thin steel wire. An optical cuff, made of 16 LEDs (Rohm, SMLP12BC7T, 465 nm) arranged in a concentric perimeter facing the peripheral nerve center, or a bipolar hook electrical cuff was inserted around the exposed sciatic nerve that is cut proximal to the site of stimulation. In most cases optical and electrical stimulation were conducted in the same leg at different times. Stainless steel hook electrodes were inserted for differential EMG recordings. EMG recordings were filtered in hardware only (BP 3-3000 Hz). All force, EMG, and stimuli data were sampled at 100 kHz.

[0106] Imaging was implemented consistent with the following steps. Fresh sciatic nerve was fixed in 4% PFA for 30 min and washed in PBS. The samples were then embedded in 5% low-melting point agarose and cut ($50\ \mu\text{m}$) with a vibratome. The sections were labeled with anti-tau and anti-lamin. The sections are imaged on a confocal microscope (Leica, DM6000). The number, size and fluorescence intensity of the motor axons ($\geq 3\ \mu\text{m}$ and G-ratio ≥ 0.5)^{33, 34} were determined by manual analysis in ImageJ.

[0107] All other data analysis was conducted in Matlab. All data reported for the MG was broken in arbitrarily defined bins based on iEMG value. To determine stimuli needed for 95% maximum iEMG in SOL and LG, a Weibull cumulative distribution function was fit to data points. The confidence interval (c.i.) generated by the curve fit was used to define the 99% c.i. of the required stimuli.

[0108] Samples tested for statistically significant differences were first tested for normality using Lilliefors test ($\alpha=0.05$), then tested using unpaired two-tailed Student's t-test ($\alpha=0.05$). All sample groups tested were found to be of normal distribution, except for the axon size data which was tested using the Mann-Whitney U-test. All data points listed are mean \pm s.e.m. or data \pm 99% confidence interval (c.i.) when referring to FIGS. 7C and 7D.

[0109] The specific implementations of the above-mentioned experiment, while instructive, are not meant to be limiting. The results, however, show the versatility and broad-applicability of related methods, devices and treatments, some of which are discussed hereafter.

[0110] In a specific implementation, the desired physiologic order is exaggerated by expressing inhibitory NpHR in the fast-twitch fiber motor neurons, providing a method to reduce or prevent fatigable muscle usage when not desired. This, however, might require long periods of yellow light production, causing possible heating and reduction of battery life. Mutant forms of channelrhodopsin that respond to different light frequencies can be used by expressing these different forms of ChR2 in slow and fast twitch fiber motor neurons, thereby creating a definitive system where each could be controlled separately using the different light frequencies. Variations and combinations are contemplated including, but not limited to, multiple forms of ChR2 used in combination with NpHR.

[0111] Targeted expression can be accomplished using a cell specific promoter. Examples of cell specific promoters are promoters for somatostatin, parvalbumin, GABA α 6, L7, and calbindin. Other cell specific promoters are promoters for kinases such as PKC, PKA, and CaMKII; promoters for other ligand receptors such as NMDAR1, NMDAR2B, GluR2; promoters for ion channels including calcium channels, potassium channels, chloride channels, and sodium channels; and promoters for other markers that label classical mature and dividing cell types, such as calretinin, nestin, and beta3-tubulin.

[0112] Other aspects of the present invention use spatial properties of the light stimulus to control the activation of the desired motor neurons. For instance, the use of a LED-based nerve cuff, e.g., a stimulation device **202**, includes controllable light sources that provide illumination from respective portions of the cuff. The light sources in the different portions of the illumination device are designed to be separately addressable. Calibration techniques can be used to determine the optimal stimulus profile. For example, it may be determined that optical stimulation from a first portion of the illumination device activates higher percentage of fast twitch fiber motor neurons with respect to optical stimulation from another portion of the illumination device. Optical stimulus from this portion can be reduced or avoided altogether when fine motor control is desired. Similarly, when NpHR is used, yellow light can be used from such a portion to reduce activation of fast twitch motor neurons.

[0113] According to embodiments of the present invention, an optical stimulation system is configured to provide graduated levels of optical stimulation according to the desired muscle contraction strength. For fine motor control, the optical stimulation is relatively low and/or targeted at the slow twitch motor neurons. For increasingly strong and/or rapid contractions, additional motor neurons are recruited including the fast twitch motor neurons. The graduated levels can be implemented as a function of the respective ratio of fast to slow twitch motor neurons that are responsive to a particular aspect of the optical stimulation. Example aspects include the optical wavelength, optical intensity, duration of optical stimulus and/or the location of the optical stimulus. A stimulation profile can then be determined to provide the desired responsiveness ranging from slow/fine control to fast/coarse control of the particular muscle group. This can be implemented using an algorithm that takes a desired response and determines the optical parameters corresponding to the response. Alternatively, a look-up table, having stored optical parameters that are indexed according to the desired motor response, can be used.

[0114] Optogenetic techniques offer novel therapies in several areas. Example applications include, but are not limited to, muscle stimulation, spasticity, tremor, chorea suppression, pain management, vagus, phrenic, and sacral nerve stimulation, cardiac arrhythmia management, and stem cell therapies.

[0115] Embodiments of the present invention relate to treatment or characterization of a patient suffering from spasticity. Spasticity is a devastating and common human clinical condition that arises as a result of neonatal injury (e.g., cerebral palsy), genetic disease (e.g., Niemann-Pick disease) and postnatal injury (e.g., spinal cord injury and stroke), and is characterized by hyperreflexia which leads to involuntary muscle contraction in response to movement. Spasticity limits the daily activities of more than millions worldwide, and is estimated to cost billions of dollars in the United States alone. There are a number of medical and surgical treatments for spasticity, including botulinum toxin, intrathecal baclofen, selective dorsal rhizotomy, and gene therapy; however most, if not all, can cause significant side-effects, have limited efficacy, and can be prohibitively expensive. It is extremely difficult to “turn down” the overactive nerves that cause severe muscle contraction, abnormal posture, and pain, since drug approaches are slow and nonspecific with regard to cell type, and electrodes cannot effectively or precisely turn down neural activity, or attain cell type specificity. In many cases

physicians will resort to risky surgeries like dorsal rhizotomy, but this can only be done in a minority of spastic patients and has inconsistent efficacy with the potential for serious adverse events.

[0116] Consistent with an embodiment of the present invention, both ChR2 and NpHR channels/pumps are expressed in the affected motor neurons, and a nerve cuff, or other light source capable of producing both yellow and blue light, is placed around the nerve. The combination of both ChR2 and NpHR allows for spasticity to be reduced while maintaining muscle function and strength. The stimulation pattern could either be based on a learned feedback pattern (such as those used to control prosthetic limbs) or could be controlled more explicitly by the user (deciding, for example, to leave the muscle limp for a period of time in order to rest).

[0117] For instance, the spastic motor control can be effectively overridden using a combination of ChR2 and NpHR stimulation. Electromyography devices can be used to detect the activation signal of muscles, e.g., a sensor/microchip can be implanted in muscles to detect electrical signals from the brain. These signals are transformed into corresponding optical stimulus. A trained technician or biomedical engineer can configure an initial (coarse) response relative to the optical stimulus device. Over time the patient can learn to finely control the optical stimulus device so as to perform the desired movements.

[0118] In a similar manner, optogenetic therapy is used to control tremors or various forms of chorea. Motion detection coupled in a feedback manner to ChR2 and NpHR stimulation could effectively provide a low-pass filter for muscle activation, or one in which certain patterns of activation (the specific tremor or choreic motions) were dampened. For example, accelerometers or gyros can be used to provide motion-detection associated with the muscle responsive to the stimulation. In response to motion exceeding a threshold level of forcefulness, speed and/or repeated motions, dampening stimulation can be provided. The threshold level can be adjusted to allow for suitable movement by the patient while also providing sufficient dampening functionality. The optical stimulation device can have an adjustable setting for this dampening functionality.

[0119] In one implementation, one or more additional accelerometers or gyros can be placed at the core of the patient. These accelerometers or gyros detect motions associated with the entire individual rather than a specific limb or other body part. When such motion is detected, it can be used to distinguish between motions caused by external forces (e.g., riding in a vehicle) from unwanted spastic motions.

[0120] Other embodiments of the present invention relate to treatment or characterization of chronic pain. Millions of people are adversely affected by chronic pain. Chronic pain causes billions of dollars a year in medical costs, lost working days, and workers compensation, and is a major risk factor for depression and suicide.

[0121] Pain can be divided into two general categories: nociceptive and neuropathic. In the former, mechanical, thermal, or chemical damage to tissue causes nociceptor response and initiates action potentials in nerve fibers. Afferent fibers terminate directly or indirectly on transmission cells in the spinal cord that convey information to the brainstem and midbrain. Neuropathic pain, in contrast, involves a miscoding of afferent input; mild inputs yield dramatic pain responses, through mechanisms that are not well understood. Often this is the result of an initial nociceptive pain that, instead of

resolving with healing of the initial stimulus, proceeds to spontaneous pain and low-threshold for light touch to evoke pain. It is believed that increased sodium channel and decreased potassium channel expression in dorsal root ganglia, the development of “cross-talk” between adjacent afferents, or an increase of glutamate release in spinal cord neurons are among the possible mechanisms for this increased pain sensitivity.

[0122] Treatment of pain depends on many factors, including type, cause, and location. There are myriad options, most notably topical agents, acetaminophen and NSAIDs, antidepressants, anticonvulsant drugs, sodium and calcium channel antagonists, opioids, epidural and intrathecal analgesia, acupuncture and other alternative techniques, botulinum toxin injections, neurolysis, cryoneurolysis, spinal cord stimulation, neurosurgical techniques, radiofrequency ablation, peripheral nerve stimulation, transcutaneous electrical nerve stimulation, and rehabilitation therapy.

[0123] So many treatments exist, however, because each has limitations. For example, local anesthetic drugs block sodium channels, preventing neurons from achieving action potentials. However, effectiveness of this treatment is limited by the degree to which specificity for pain neurons can be maintained, avoiding the side effects of numbness or paralysis from blocking other sensory or motor fibers (as well as potential cardiac effects should the drug travel further through the circulatory system). In order to achieve this, low dosages are needed, requiring frequent administration of the drug. Additionally, not all kinds of pain react to local anesthetic treatment, and some cases become refractory over time, or require ever increasing doses.

[0124] Surgical treatments, including dorsal or cranial nerve rhizotomy, ganglionectomy, sympathectomy, or thalamotomy, are more drastic options, appropriate in certain severe cases. However, relief from these is unpredictable; notably, it is sometimes only temporary, and may involve complications. Spinal cord stimulation (SCS) is also used in some cases, attempting to limit chronic pain through placement of electrodes in the epidural space adjacent to a targeted spinal cord area thought to be causing pain; however, a recent review found limited evidence of the effectiveness of this technique.

[0125] Alternately, pain can be addressed in the brain. As it is correlated with depression and anxiety, pain is sometimes responsive to antidepressant and anti-anxiety medications such as the tricyclics. Recent promising research suggests the effect of real-time fMRI biofeedback, where patients learn to decrease activation of the rostral anterior cingulate cortex, with resultant reduction in perceived pain. While each of these methods is effective in some cases, chronic pain remains a largely intractable problem. NpHR and ChR2 expression in peripheral afferent nerves is therefore used to influence pain signals.

[0126] Control of the peripheral afferent fibers with the high temporal precision of optogenetic techniques offers the ability to inhibit pain signals at a given moment, as with local anesthetic treatment. For instance, NpHR can be engineered in afferent nerves and optical stimulus can be provided to the NpHR to provide anesthetic treatment. The optical stimulus can be relatively constant or responsive to an external control. For instance, a doctor or patient can control the delivery of the optical stimulus in terms of frequency of stimulus, intensity of stimulus or simply turn the stimulus on or off. The temporal properties of ChR2 and NpHR can also be used to interface

with and reprogram pain recognition in the CNS. Reprogramming can be implemented as suggested by electrical stimulation, antidepressant medication and biofeedback mechanisms.

[0127] The temporal precision and nerve specificity of optogenetic stimulation is particularly useful for reprogramming pain recognition circuits. Response to pain can be “turned up” in neuropathic conditions, creating hypersensitivity to afferent stimulation, suggesting that it is possible to reverse this through other patterns of stimulation. Particular embodiments relate to stimulating pain fibers and larger sensory fibers separately, as larger sensory fiber messages tend to overwhelm and turn down pain fiber recognition.

[0128] Embodiments of the present invention also relate to vagus nerve stimulation. The vagus nerve is composed of both afferent and efferent pathways. In the peripheral nervous system, vagal afferent fibers innervate the heart, vocal cords, and other laryngeal and pharyngeal muscles, and also provide parasympathetic input to the gastrointestinal viscera. Afferent fibers project mainly to the brain, in such regions as the pontine and midbrain nuclei, the cerebellum, thalamus, and cortex.

[0129] Given this variety of nerve function, vagus nerve stimulation is used for a wide range of treatments, including appetite management, cardiac rate suppression, depression, and epilepsy. In the latter two, effectiveness of the treatment is not well understood. The right vagus nerve provides more innervation to the cardiac atria than the left vagus nerve does, so in situations where cardiac effects are not desirable, electrical stimulation is generally performed on the left side. However, even with these precautions, side effects such as hoarseness, throat pain, coughing, shortness of breath, tingling, and muscle pain are relatively common in patients receiving vagus nerve stimulation. Even more dangerous, bradycardia followed by transient asystole is reported in association with tests during stimulator implantation and there is one case report of bradycardia and asystole with syncope in a patient after two years of wearing the device.

[0130] Optogenetic techniques are particularly useful for parsing through the various functions of the vagus nerve and to stimulating only the particular neurons that are of interest. Selective stimulation mitigates the unwanted side effects, particularly the potentially life-threatening cardiac events.

[0131] Aspects of the present invention are also particularly useful for studying the effects of vagus nerve stimulation. Little is known about why vagus nerve stimulation is effective in treating epilepsy and depression. Optogenetic techniques provide a means of studying and improving these treatments. In animal models, ChR2 expression in various types of vagal fibers allows for the identification of the specific fibers best suited for stimulation. Once these fibers of interest are identified, therapies could be modulated so that only these fibers are stimulated, thus avoiding unwanted side effects.

[0132] In certain embodiments, inhibition is desired, rather than stimulation. Vagus nerve techniques for appetite suppression involve either severing the nerve or over-stimulating it so that it no longer has meaningful effect on the gastrointestinal system. However, damage to the vagus nerve can cause gastroparesis, where the stomach no longer propels food forward through the digestive system, causing nausea, vomiting, and dangerous fluctuations in blood sugar levels.

[0133] In one such embodiment, NpHR is used to provide a more targeted technique to depress vagus nerve firing. The optical stimulation of the NpHR can be provided to specific

times, such as during meals, to more closely mimic natural physiology. For example, optical stimulation could be responsive to patient input indicating consumption of food. Alternately, one could bypass the vagus nerve and instead express ChR2 in the muscles of the proximal stomach. These muscles relax to allow the stomach to expand while eating; blocking or mitigating this expansion through ChR2 stimulation would create a premature sense of satiety, similar to the effects of gastric bypass surgery. Selection of one treatment method over the other can be determined as a function of the ability to directly control stomach muscle movement against the complexity of needing a light source for the entire stomach muscle region rather than a small cuff for the vagus nerve.

[0134] Other aspects of the present invention relate to cardiac applications. Abnormal heart rhythms, such as atrial fibrillation or atrial flutter, are often treated using defibrillation and cardioversion. These treatments are based on the concept of creating a large electrical field to interrupt the abnormal heart rhythms, thereby allowing the heart to return to normal rhythm. This is also the basis for external defibrillation, used to resuscitate patients that otherwise would die using an external shock system. Implantable defibrillators have become the standard of care in patients felt to be at high risk for life-threatening rhythm abnormalities called ventricular tachycardia or ventricular fibrillation. These devices have several major limitations—one of the greatest limitations is the need for a painful shock and potential for symptoms prior to conversion due to the inability of the device to prevent the rhythm from occurring or progressing prior to the shock. The shock is not desirable since it is painful and creates patient anxiety, resulting in an impairment of quality of life.

[0135] For atrial arrhythmias such as atrial fibrillation, techniques such as catheter ablation often do not completely eliminate atrial fibrillation. Since there are estimates of millions of patients currently with atrial fibrillation, a substantial numbers of patients may remain in atrial fibrillation. Atrial fibrillation results in an increased risk of stroke in most patients and may be highly symptomatic. For many of these patients, electrical cardioversion is possible but requires anesthesia to be administered with its resulting inconvenience and cost. Implantable defibrillators, although approved for this indication, have not been utilized for atrial fibrillation: the discomfort of the shock is not well tolerated, and only about 50% of atrial fibrillation episodes are converted by maximum energies in current implantable defibrillators.

[0136] Consistent with a specific implementation, local activation of cells in specific regions or with specific cell types is used to assess the role of the cells in the genesis of arrhythmias. There are two fundamental mechanisms that might be employed to convert atrial or ventricular arrhythmias. The first mechanism brings localized regions of heart tissue in specific geometric relationships to reach subthreshold potential so that the abnormal rhythm stops. The second mechanism controls afferent sympathetic and parasympathetic nerves with optical stimulation. In the first mechanism, the subthreshold regions create firewalls around the regions of initiation of the ventricular tachycardia or ventricular fibrillation so that the rhythm would not actually start, while in the second mechanism the vagus nerve itself (for example) can be accessed at a position where the cardiac fibers are still embedded.

[0137] Embodiments of the present invention are particularly useful for replacement or supplementation of electrical stimulation therapies that target phrenic and sacral nerves.

The phrenic nerve controls the diaphragm, and implantable electrodes can be used as an alternative to mechanical ventilators for long term ventilation-support needs. Because the phrenic nerve is relatively isolated and has few functions beyond diaphragm control, electrical stimulation is generally an effective technique. Side effects, however, come from the initial surgery to implant the electrodes, which may include thoracotomy. There is also report of chest pain with stimulation at high intensity, due to simultaneous stimulation of phrenic nerve afferent fibers, though this is generally fixed by lowering the stimulation levels.

[0138] Optogenetic techniques can be useful for avoiding the need for thoracotomy to implant the electrodes. With the specificity provided by genetic targeting, accidental stimulation of unwanted nerves can be mitigated or completely prevented. Therefore an LED cuff (or alternate light source) could be installed above the rib cage, where the nerve first leaves the spinal cord. This would avoid the need for a potentially dangerous thoracotomy, and would hasten post-operative recovery time.

[0139] The sacral nerve influences bladder and bowel control, and may be damaged either in paraplegia, or as a side effect of radical prostatectomy. Correct bladder control is the product of careful coordination of the detrusor and sphincter muscles, as controlled by sacral nerve parasympathetics and thoracic nerve sympathetics. While filling, the sphincter muscles must remain strongly activated, while the detrusor muscles relax to allow the bladder to stretch, as monitored by stretch receptors. Bladder release requires coordination of these same muscles in the opposite fashion: sphincter muscles release followed by detrusor muscle contraction. Failure to synchronize these events is known as detrusor-sphincter dysenergia (DSD).

[0140] Electrical stimulation suppresses hyperreflexia of the detrusor muscle, allowing for increased bladder filling and increased time between voiding, however DSD is sometimes a side effect of stimulation. Alternately, dorsal rhizotomy is sometimes performed to increase bladder capacity and provide urinary continence. However, both of these techniques are clearly limited; one can either stimulate or cut innervation, but not do both in carefully timed succession as would be needed for true restoration of function. With the genetic targeting techniques, and light cuffs implanted around the sacral and thoracic nerves, optogenetic techniques allow control of the sphincter and detrusor muscles, so that stimulation and inhibition of each could be achieved with high synchrony, effectively recreating normal bladder physiology.

[0141] Other embodiments of the present invention relate to uses of stem cells. The success of bone marrow transplantation demonstrates the great promise of stem cell research. However, in many areas of stem cell research, potential therapies still face major technical hurdles. While injected stem cells will often successfully repopulate cells in the needed area, it is difficult to guarantee that these new cells will perform the needed function.

[0142] One promising field of research is the use of skeletal myoblasts and stem cells to treat myocardial infarctions and heart failure. Intravenous injection of these cells does improve cardiac function, but there is significant concern that the treatment may be arrhythmogenic, either because of the electrical properties of the injected cells, or because of damage or increased nerve sprouting from the injection.

[0143] A second major research area is the use of stem cell injections to treat spinal cord injury. Here it is difficult to establish what types of cells are most appropriate in order to bridge the injured area and to restore function. A cell that is less differentiated has more potential to react to the environmental cues to produce the needed variety of cells; however, it also has more potential to differentiate to produce unwanted cell types, creating the danger of teratomas and other cancerous growths. Also, even once the cells are in place, they may or may not integrate into the neural circuit and become functional.

[0144] Optogenetic techniques can be used to solve some of the problems faced by stem cell therapies, particularly in cases such as the cardiac, muscular, and nervous systems, where the cells need to perform specific electrical tasks. Stem cells are often genetically modified prior to injection; the inclusion of ChR2 and NpHR would allow direct control of the electrical properties of the transplanted cells, insuring that cells will be functional.

[0145] In the case of myocardial repair, tonic NpHR inhibition could be used to prevent arrhythmia, as discussed previously. A detector noting changes in the potential fields around cardiac pacemaker cells could trigger stimulating light pulses, so that the new cells would fire in synchrony with the native myocardial cells.

[0146] With spinal cord injury, it may be possible to use optogenetically modified stem cells directly at the site of injury. Knowledge of the complex circuitry can be used to determine and provide the needed light stimulation patterns. An alternative implementation uses modified skeletal muscle stem cells (“satellite cells”) to repopulate muscles with cells that are responsive to optical control. For example, after spinal cord or nerve injury, denervated muscle begins to atrophy from lack of use. Rather than attempt to reinstitute peripheral nerve supply, one could use optical stimulation to control a newly grown population of skeletal muscle cells.

[0147] Muscle fibers evolve and change type from slow to fast twitch and the reverse, according to patterns of stimulation. Accordingly coordination of stimulation patterns to specific muscle types is implemented. Establishment of different populations of satellite cells that respond to different frequencies of light allows for independent control of slow and fast twitch muscle fibers.

[0148] For the various embodiments of the present invention discussed herein, one concern is the ability to effectively use gene therapy without significant side-effects. Animal studies have thus far shown that the expression of these types of foreign proteins in neuron cell membranes does cause an immune response. Notwithstanding, inflammatory effects can be countered using oral peptide-tolerization strategies or mild oral immunosuppression strategies, which can specifically reduce inflammatory responses. Further advances in gene therapy and immune suppression techniques will help to minimize these risks.

[0149] Moreover, these types of side-effects are relatively minor when compared to many of the severe ailments that can be treated, such as for intense chronic pain and severe cardiac arrhythmias. With progressively safer genetic techniques, the therapies proposed herein become increasingly viable, and optogenetic therapies may be the preferred approach even when they offer only slight benefits over traditional techniques.

[0150] The invasiveness of implantation surgery, scarring around electrodes or light sources, longevity of electronics

and power supplies, and battery requirements in the case of power supply implantation, or possible infection risks if wire leads are needed to connect to a power supply outside the body can be mitigated using biocompatible materials and/or power supplies.

[0151] While the present invention has been described above, the skilled in the artisan will recognize that many changes may be made thereto without departing from the spirit and scope of the present invention. Such changes may include, for example, the implementation of one or more approaches involving variations of optically responsive ion channels. These and other approaches as described in the contemplated claims below characterize aspects of the present invention.

What is claimed is:

1. A method comprising:
 - engineering light-responsive channels or pumps in a set of motor units that includes motor units having respective motor neurons of different physical sizes;
 - determining an optical stimulus profile as a function of a recruitment order of the set of motor units that corresponds to the different physical sizes of the motor neurons; and
 - providing the optical stimulus profile to the light-responsive channels or pumps.
2. The method of claim 1, wherein the step of determining an optical stimulus profile includes correlating an activation of increasingly larger physical sizes of the motor neurons to the optical stimulus profile.
3. The method of claim 1, wherein the step of determining an optical stimulus profile includes correlating a muscle fatigue factor to the optical stimulus profile.
4. The method of claim 1, wherein the step of providing optical stimulus profile includes increasing an intensity of providing optical stimulus profile to recruit motor units having increasingly larger motor neurons.
5. The method of claim 1, wherein the step of providing the optical stimulus profile is implemented using a curved optical delivery device that at least partially surrounds the motor neurons of the set of motor units.
6. The method of claim 1, wherein the step of engineering includes
 - engineering, in fast twitch motor units, first light-responsive channels having a first optical response profile; and
 - engineering, in slow twitch motor units, second light-responsive channels having a first optical response profile, wherein the first optical response profile and the second optical profile have respective peak sensitivities to different wavelengths of light.
7. The method of claim 6, wherein the step of providing the optical stimulus profile includes providing an optical stimulus at a wavelength sufficient to activate the slow twitch motor units without activating the fast twitch motor units.
8. The method of claim 1, further including the step of sensing a neural activation signal and wherein the step of providing optical stimuli is responsive to the sensed neural activation signal.
9. The method of claim 1, further including the step of calibrating the optical stimulus profile as a function of contractile strength of the motor units in response to the optical stimulus profile.
10. The method of claim 1, further including the step of sensing spastic motion of a portion of the body and wherein

the step of providing the optical stimulus profile is responsive to the sensed spastic motion and mitigates the spastic motion.

11. The method of claim **1**, wherein the light-responsive channels or pumps are one of ChR2, NpHR and variants thereof.

12. A method comprising:

engineering light-responsive channels or pumps in a set of motor units that includes motor units having respective motor neurons of different physical sizes; and

providing optical stimuli to the light-responsive channels or pumps at an optical intensity that is a function of the different physical sizes of the motor neurons to be recruited.

13. A method comprising:

engineering light-responsive channels or pumps in a set of peripheral afferent nerves; and

providing optical stimuli to the light-responsive channels or pumps to mitigate pain.

14. The method of claim **13**, wherein the step of engineering includes engineering NpHR in the peripheral afferent nerves and the step of providing optical stimuli is responsive to an external control signal indicating a desired stimulus profile.

15. The method of claim **13**, wherein the step of providing optical stimuli includes providing an optical stimulus pattern to modify pain recognition in the central nervous system.

16. A method comprising:

engineering light-responsive channels or pumps in a set of vagal fibers associated with the gastrointestinal system; and

providing optical stimuli to the light-responsive channels or pumps to mitigate appetite.

17. The method of claim **16**, wherein the step of engineering includes engineering NpHR in the set of vagal fibers and wherein the step of providing optical stimuli is responsive to an indication of meal time.

18. A method comprising:

engineering light-responsive channels or pumps in a set of skeletal muscle stem cells;

implanting the set of skeletal muscle stem cells at a target location within a muscle to repopulate the muscle; and

providing optical stimuli to the light-responsive channels or pumps to cause activation of the muscle at the target location.

19. The method of claim **18**, wherein the step of implanting includes implanting the set of skeletal muscle stem cells for myocardial repair.

* * * * *