



(19) **United States**

(12) **Patent Application Publication**

Lee et al.

(10) **Pub. No.: US 2013/0118304 A1**

(43) **Pub. Date: May 16, 2013**

(54) **HIGH TEMPERATURE REACTOR SYSTEM AND METHOD FOR PRODUCING A PRODUCT THEREIN**

Publication Classification

(51) **Int. Cl.**
C22B 4/00 (2006.01)
C22B 4/08 (2006.01)
(52) **U.S. Cl.**
CPC .. *C22B 4/005* (2013.01); *C22B 4/08* (2013.01)
USPC **75/10.19**; 266/171; 266/195

(71) Applicant: **Advanced Magnetic Processes Inc.**, Ipswich, MA (US)

(72) Inventors: **William Davis Lee**, Newburyport, MA (US); **Peter G. Marston**, Ipswich, MA (US)

(73) Assignee: **ADVANCED MAGNETIC PROCESSES INC.**, Ipswich, MA (US)

(57) **ABSTRACT**

A plasma system including a plasma source or torch such as an ICP torch acting on a granulated feed material containing a desired product is presented. Methods for employing the system are described including a process for extracting the desired product from a reaction in the plasma system, recovery of otherwise wasted heat energy, and separation of useful materials from mixed mineral substances is discussed.

(21) Appl. No.: **13/675,395**

(22) Filed: **Nov. 13, 2012**

Related U.S. Application Data

(60) Provisional application No. 61/557,951, filed on Nov. 10, 2011.

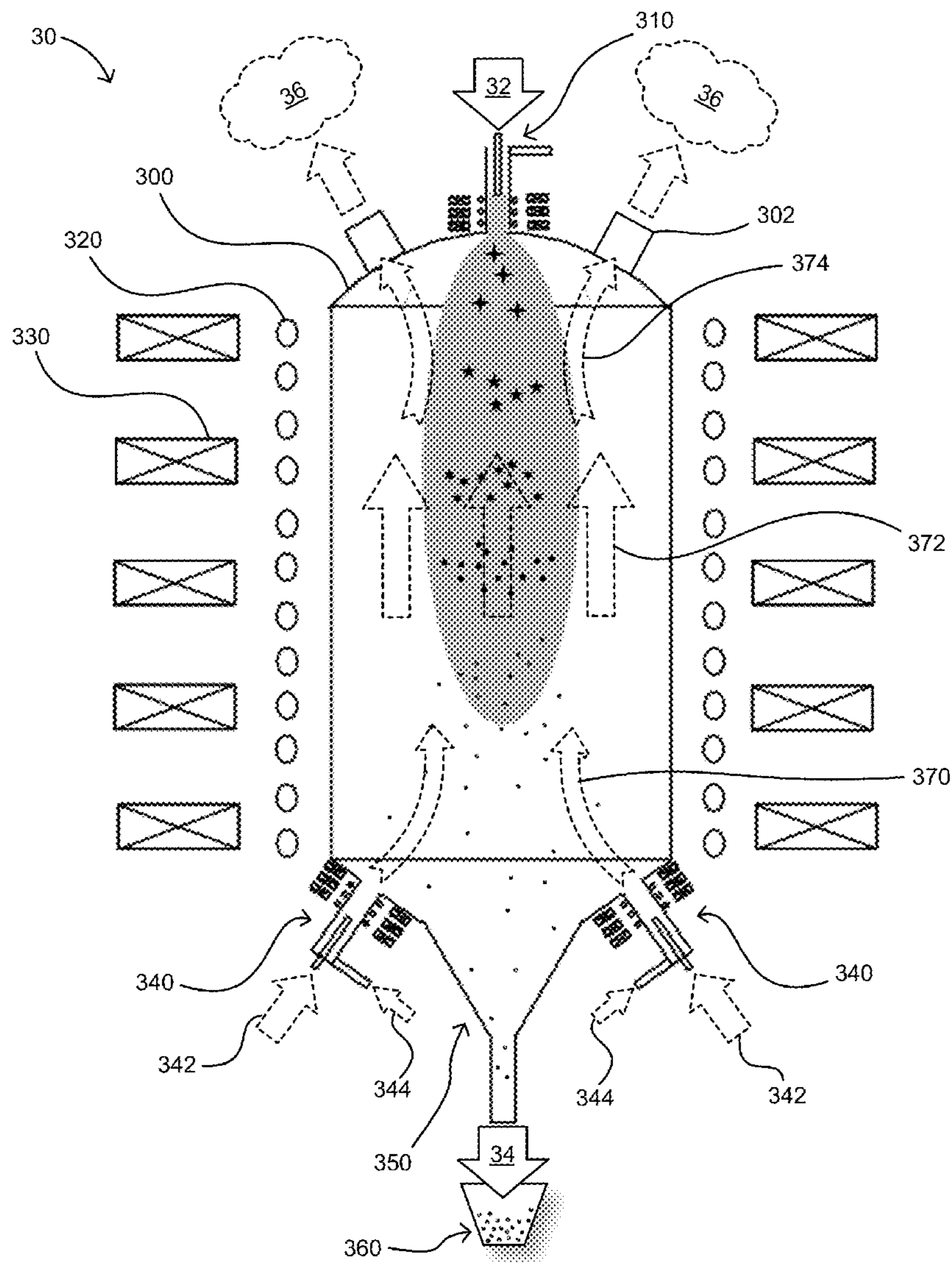

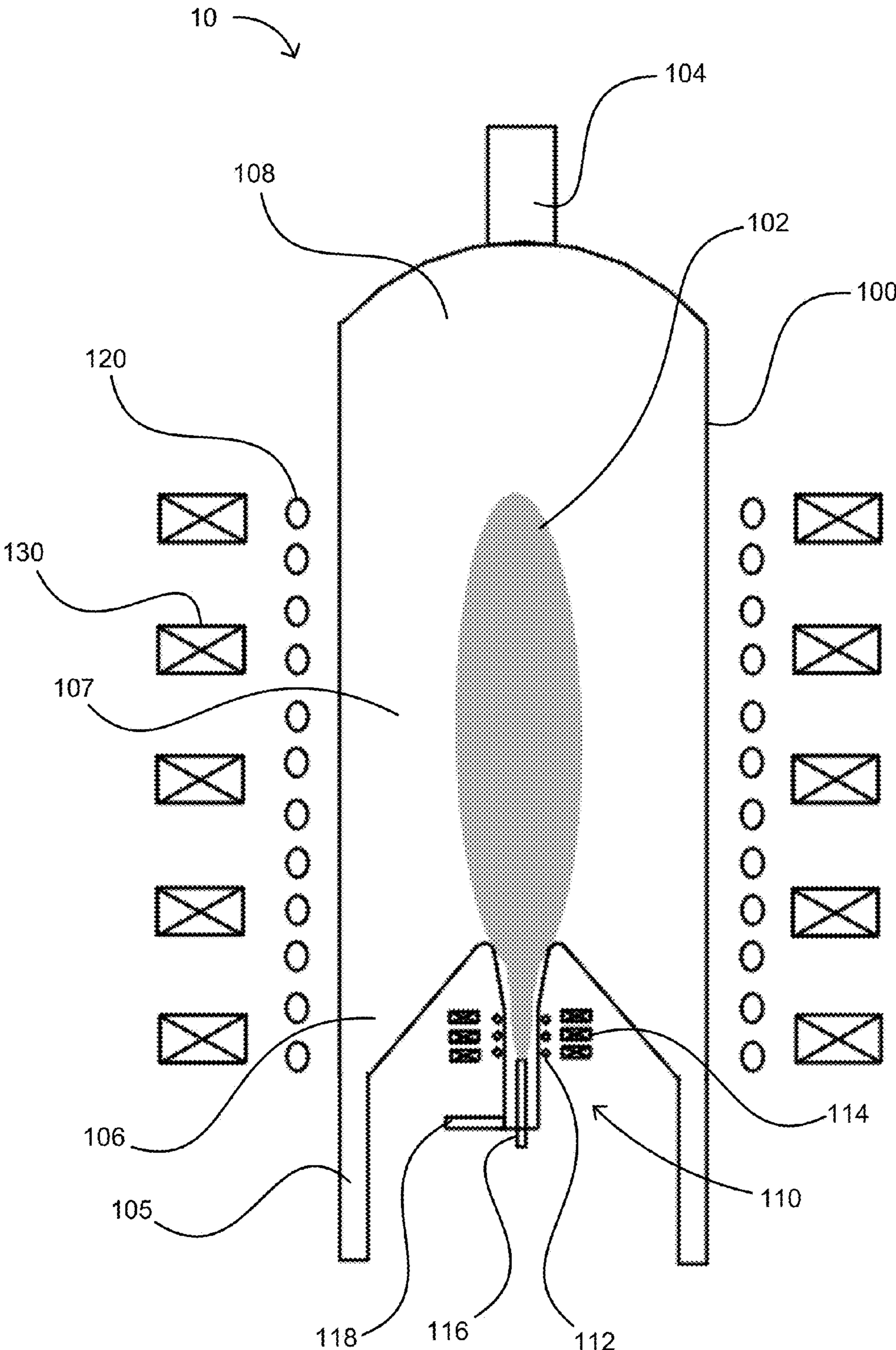

Fig. 1

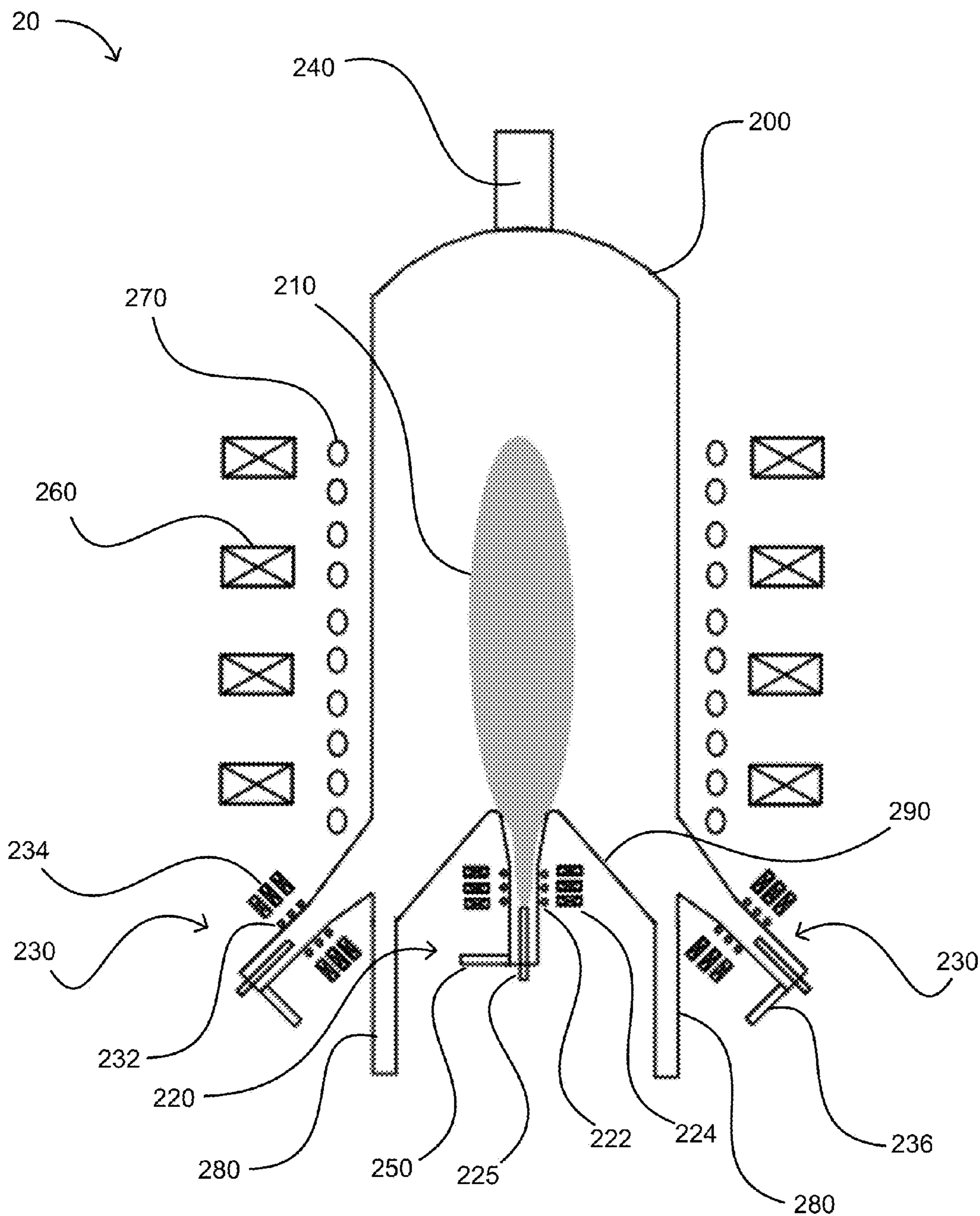

Fig. 2

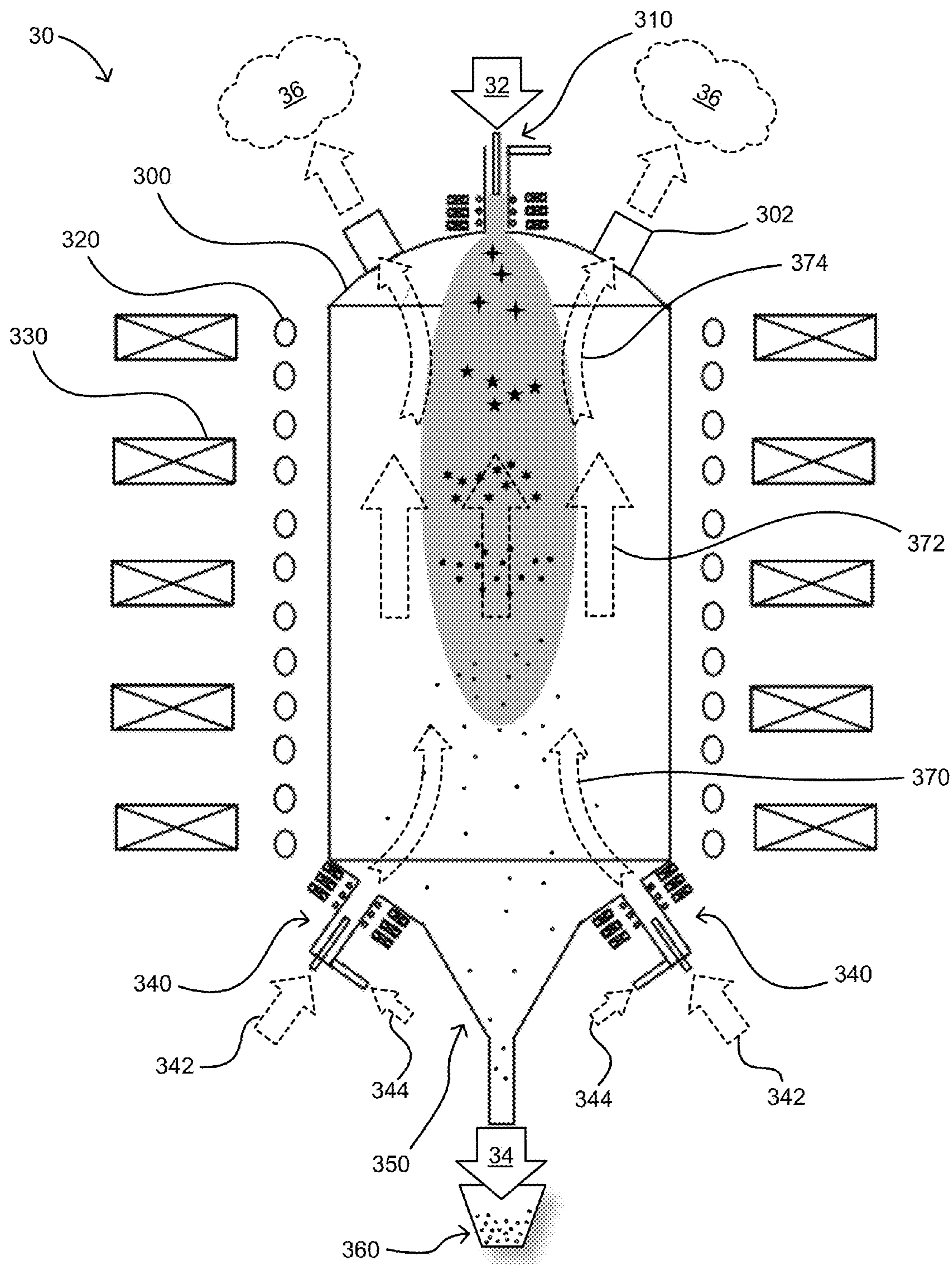

Fig. 3

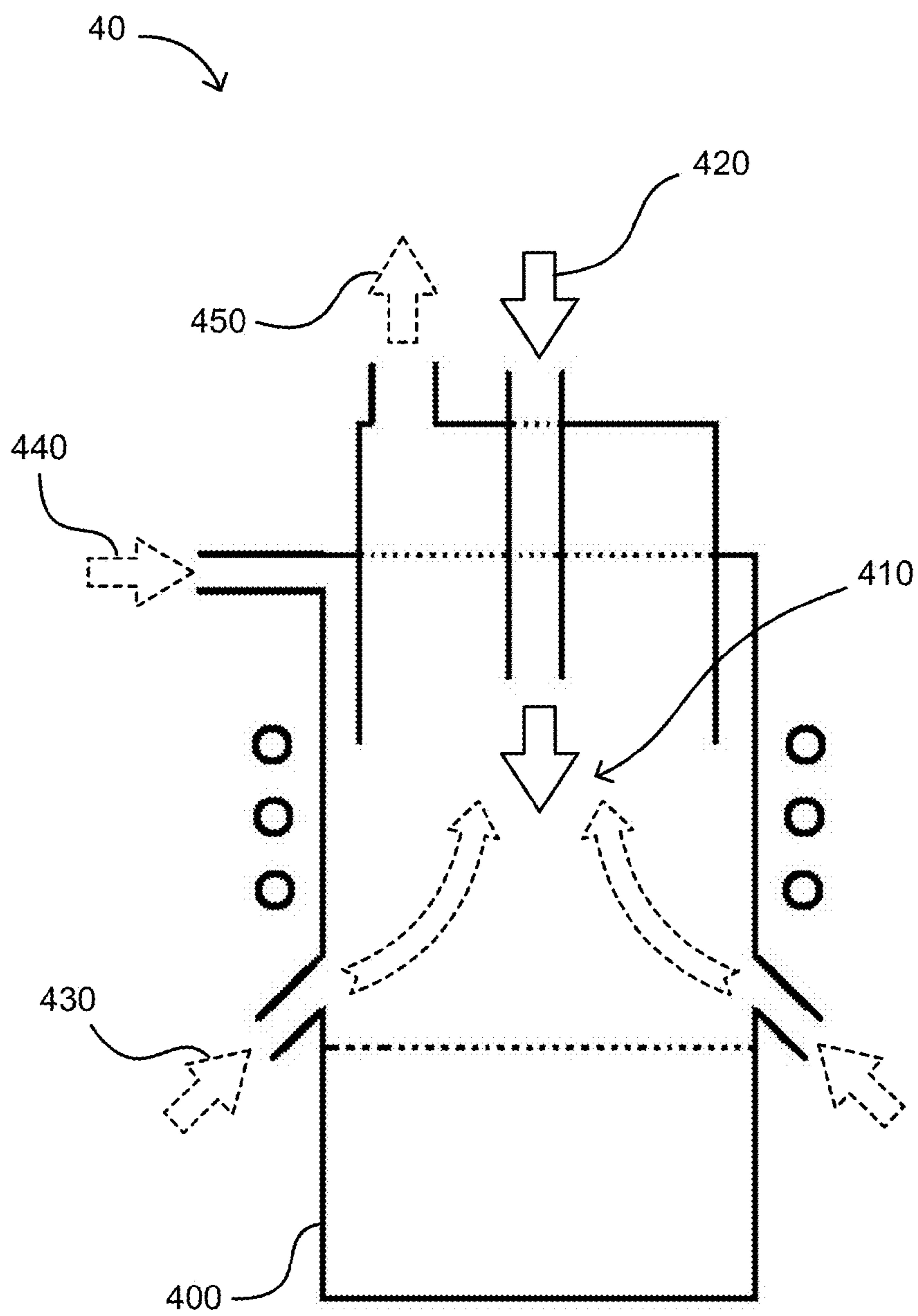

Fig. 4

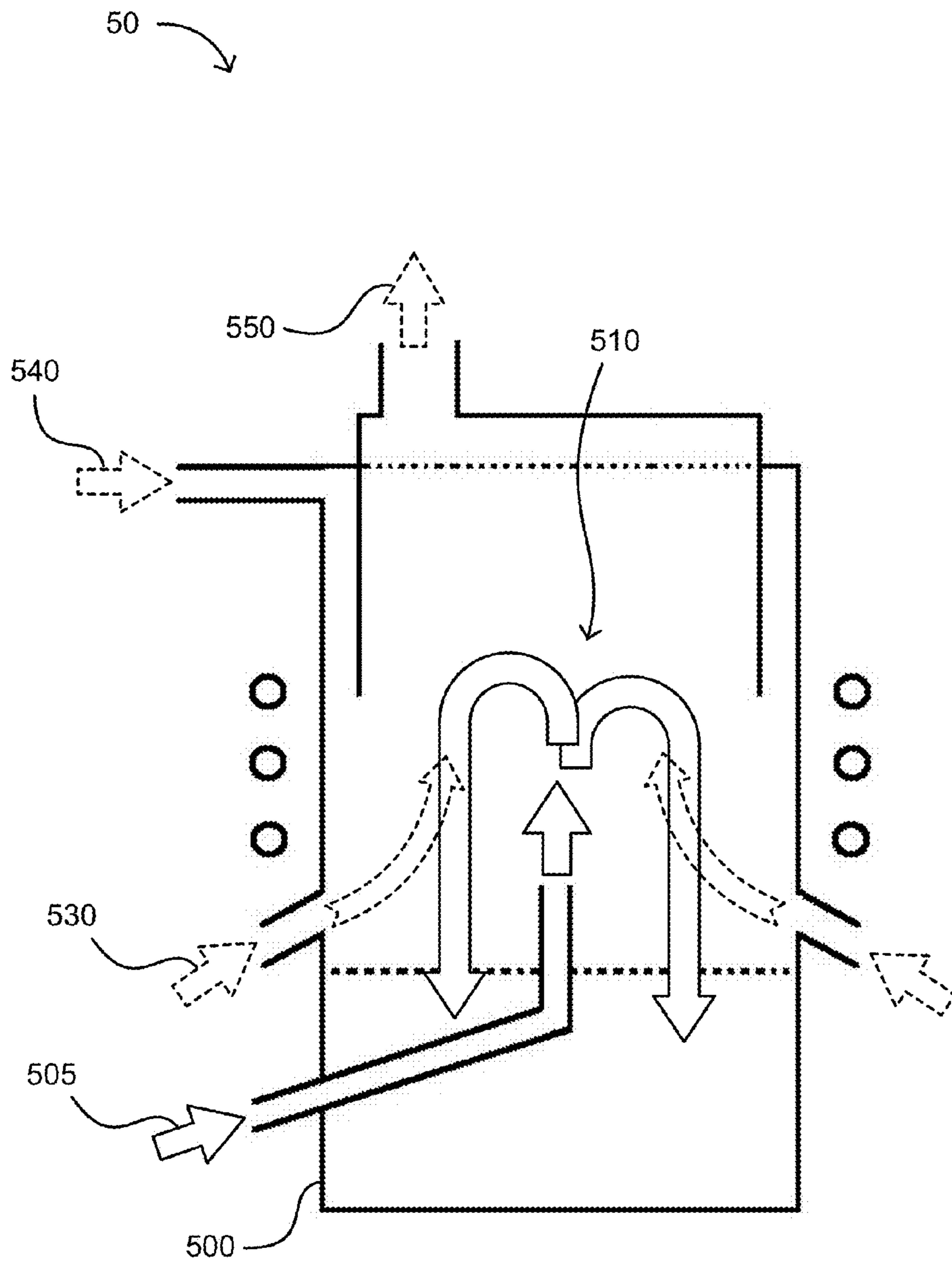

Fig. 5

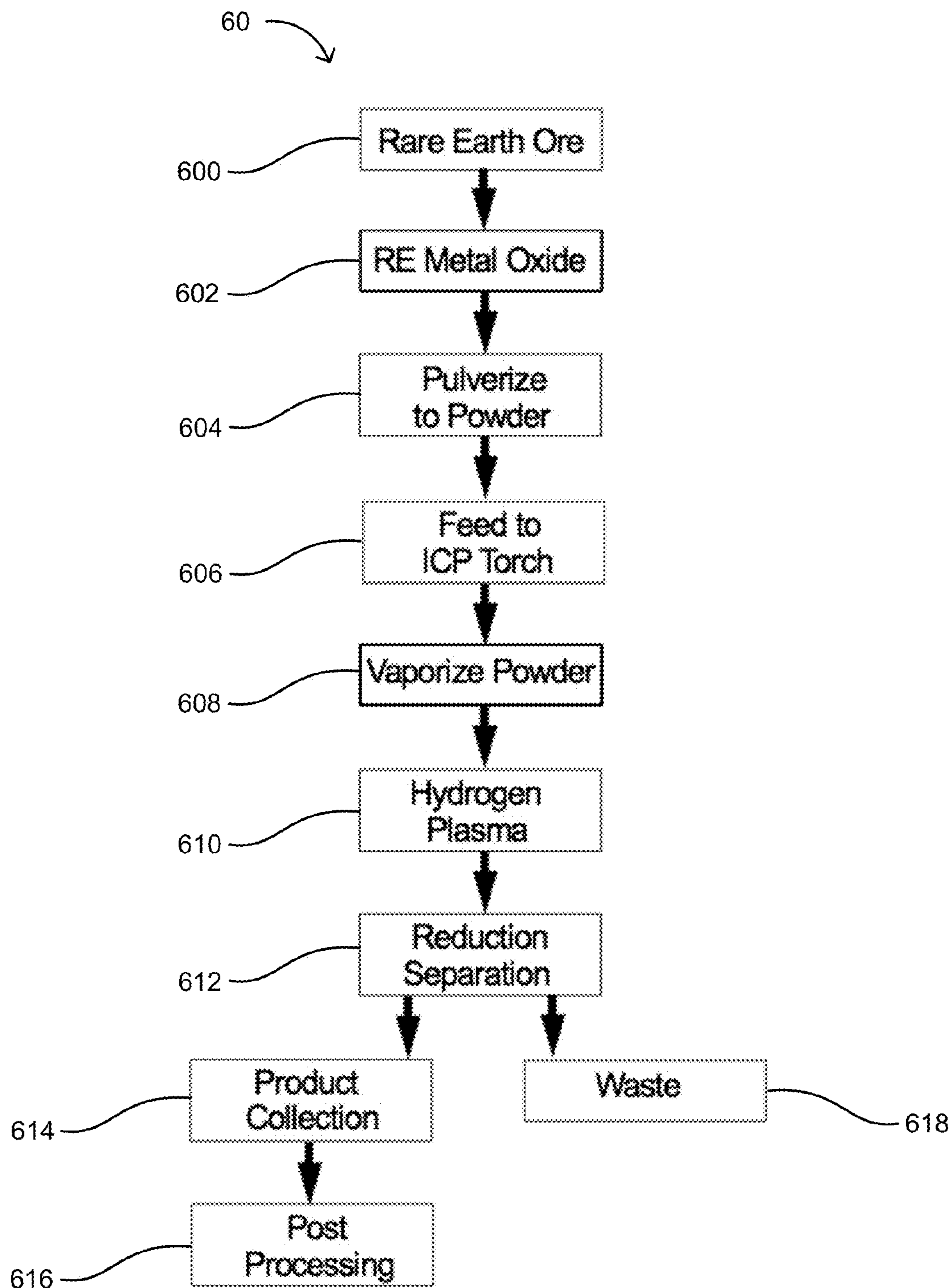

Fig. 6

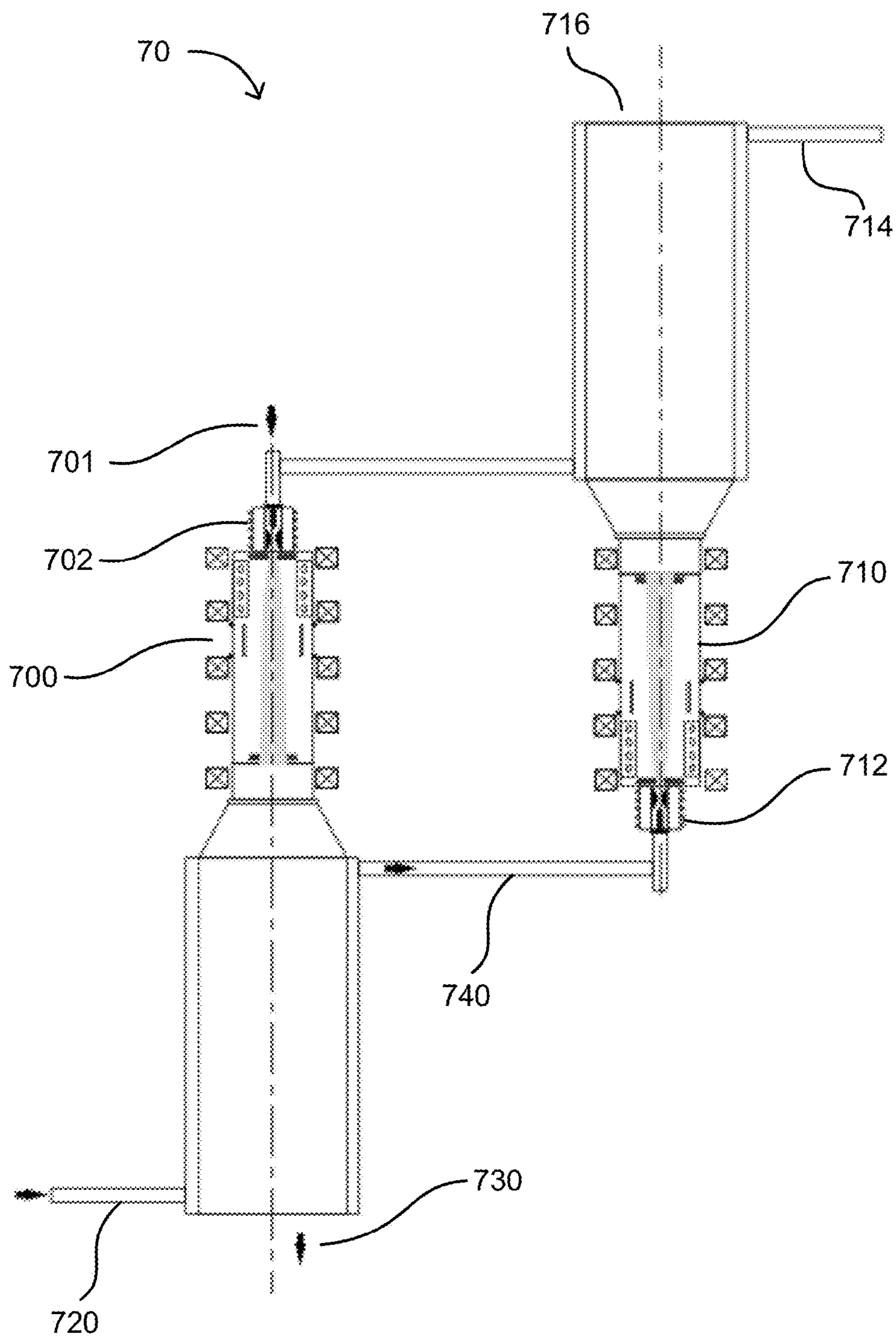

Fig. 7

**HIGH TEMPERATURE REACTOR SYSTEM
AND METHOD FOR PRODUCING A
PRODUCT THEREIN**

RELATED APPLICATIONS

[0001] This application is related to and claims the benefit and priority of U.S. Provisional Application 61/557,951, filed on Nov. 10, 2011, entitled “Magneto-Plasma Separator and Method for Separation,” to the present inventors and assignee, which is herein incorporated by reference.

TECHNICAL FIELD

[0002] The present application relates to systems and methods for applying a plasma based process to a feed material in order to extract useful products therefrom.

BACKGROUND

[0003] Rare earth elements (REEs) and other high value strategic materials are elements whose unique properties are essential to the manufacture of high-tech industrial, medical, and military technology. The REE group is considered to include the lanthanide elements: lanthanum, cerium, praseodymium, promethium (does not occur naturally), neodymium, samarium, europium, gadolinium, terbium, dysprosium, holmium, erbium, thulium, ytterbium, and lutetium. The elements yttrium and scandium are also included as they have similar chemical properties. Other materials to which aspects of this application is directed include tantalum, titanium, tungsten, niobium, lithium, palladium, vanadium, zirconium, beryllium, thorium and uranium. The above materials are referred to herein as strategic materials for simplicity. Those skilled in the art will appreciate analogous and similar materials to which the present disclosure can be applied as well.

[0004] The REEs and the other strategic materials are used in cell phones, computers, and televisions, as well as in hybrid automobiles, high speed trains, wind turbines, lasers, sonar and fiber optics. They are also important to national security, as they are used in the manufacture of guided missiles, communications satellites, radar, early warning systems, and countless other military and defense items.

[0005] Tantalum metal is an example of a high value material that is widely used in its elemental form but found in nature in the form of a salt or oxide compound. Tantalum is used to make steels with desirable properties such as high melting point, high strength, and good ductility. These find use in aircraft and missile manufacture. Tantalum is relatively inert and thus useful in the chemical and nuclear industries. The metal is also highly biocompatible, therefore, tantalum has widespread use for surgical use. For instance, it can be used in sutures and as cranial repair plates. The metal is also used in the electronics industry for capacitors.

[0006] Uranium, in its enriched form, is of particular interest as a fuel for nuclear reactors in both commercial and military applications. The overall flow sheet for Uranium includes mining, milling (to produce yellow cake), conversion, and fabrication. Each comprises a number of sub-steps. Following use of the finished product in a nuclear reactor, spent fuel may be reprocessed and/or stabilized and stored. Means for reprocessing spent fuel and management of high level nuclear waste is of great importance.

[0007] U.S. Pat. No. 3,429,691 is directed to a method for reducing titanium dioxide powder to elemental titanium. The

method combines titanium dioxide powder melted into droplets, and hydrogen plasma, producing liquid titanium and water at the other end of the chamber. The injected hydrogen plasma serves to both heat the titanium dioxide and remove the oxygen from the titanium by reduction. The reaction occurs in a compressing magnetic field in order to prevent the contents from contacting the sides and melting them.

[0008] In one example of current practice, tantalum is produced by metallothermic reduction of one of its salts. At approximately 800° C., solid potassium heptafluorotantalate (K_2TaF_7) and liquid sodium are added to a halide melt (known as a “diluent”) where they react to produce solid tantalum in the form of powder. The process involves many unit operations prior to the reduction step in order to convert ore to high quality feed. Then, the reduction step relies on a batch process involving very dangerous liquid sodium at temperatures approaching its boiling point (883° C.). The sodium must be delivered to the reactor in large vessels (railway tank cars) and stored on site. In this reactor it is difficult both to control particle size and to prevent particle agglomeration, which is critical to the production of high-grade powder for use in capacitors.

[0009] The above systems generally require highly reactive liquid sodium and costly potassium heptafluorotantalate double salt feedstock, and lack continuous throughput, and are based on batch operation methods, and further lack the capability to control particle size in the product tantalum powder.

[0010] Generally, when the constituents of a mixture or the elements within a compound have an electric charge, one method of separating them relies on accelerating the charged particles and passing them through a magnetic field that is perpendicular to their velocity. This technique of separation separates the particles based on their mass-to-charge ratio.

[0011] U.S. Pat. No. 3,722,677 is directed to a device for causing particles to move along curved paths inside a cylindrical chamber using perpendicular electric and magnetic fields, for the purpose of separating the particles. In this invention electrodes can be placed at one or both ends of the confined volume. The positively charged particles will rotate around the central axis and impart this motion to the uncharged particles through collisions. The concentration of heavier particles will be greater at greater radial distances, thus allowing separation.

[0012] One way of creating charged particles in a mixture or a chemical compound is by raising the temperature of the material to above that of its gas phase. This transforms it to a state of matter called plasma that is similar to the gas phase except that it has been heated to the degree that some portion of the molecular constituents have lost some of their electrons and are said to be “ionized”. The chemical bonds are broken thermally—the degree of ionization depends on the temperature. A plasma is thus comprised of charged particles—generally positive ions and negative electrons.

[0013] U.S. Pat. No. 6,096,220 is directed to a process and device for filtering low mass particles from high mass particles in a plasma by means of injecting the plasma into a cylindrical chamber having a magnetic field aligned with the axis, and a perpendicular electric field. The magnitude of the magnetic and electric fields are adjusted such that the high mass particles escape radially and collide with the cylindrical wall, while the low mass particles are confined to travel within the walls.

[0014] A filter generally requires only that all particles above a certain mass are trapped and all below such “certain mass” pass through—momentum resolution is not a critical design or performance issue. A separator separates and collects specific particles that represent the ionic constituents of a particular metal product. Moreover, it is often the case that there is not a large difference in the relative mass of such “product particles”. For these applications it may be helpful to obtain a measure or parameter related to momentum resolution.

[0015] U.S. Pat. No. 6,248,240 is a continuation in part of U.S. Pat. No. 6,096,220 and adds both the possibility of a non-cylindrical chamber and the possibility of the plasma source being located midway down the chamber. In addition it provides a method for maintaining a multi-species plasma at a low enough density such that collisions between the particles are relatively infrequent, and it introduces one or more collectors positioned to intercept high mass particles.

[0016] U.S. Pat. No. 6,235,202 is another continuation in part of U.S. Pat. No. 6,096,220, and adds the possibility of injecting vaporized material into the chamber, and then ionizing it inside the chamber to create a plasma, possibly by using an RF antenna.

[0017] Also, a plasma device has been described to achieve goals such as mass spectrometry. Plasma sources, e.g., a plasma torch, generally apply intense radio frequency (RF) fields to an injected plasma gas (e.g., Argon-Ar) and auxiliary gas feeds to ionize them and induce collisions between the accelerated gas molecules to generate a plasma flame. A nebulizing substance may be injected into the reaction zone of the plasma source as fine droplets. Temperatures up to about 3000 Kelvin (K) are generated in the process, and have been said to cause favorable dissociation of substances, for example to remediate harmful wastes.

[0018] U.S. Pat. No. 3,429,691 purports to provide a method yielding elemental titanium (Ti) by reducing finely divided liquid titanium dioxide with hydrogen plasma in a counter-current flow to recover the elemental Ti recovered in its liquid state. The system of the '691 reference provides temperatures purporting to range between 2500K and 3540K, which would not meet the requirements for certain applications to be described below. Additionally, while the prior art includes a plasma arc jet it lacks sufficient other technical elements and capabilities, allowing it to be used in some applications, but falling short of being suited for other applications of interest herein.

[0019] Beyond that recognized in the prior art, the present systems and methods improve mineral extraction efficiency, lower process and system costs and complexity, increase yield, reduce the resultant price of REEs and other high value strategic materials, and reduce the time required to bring a new ore body into production.

SUMMARY

[0020] Some embodiments are directed to a plasma reactor system for extracting a product from a feed material, including a reaction chamber having walls substantially defining an enclosed volume of said chamber including at least one reaction zone; a plurality of ports for ingress and egress of materials into and out of said chamber; a set of induction coils that generates temperatures within said reaction zone to cause a reaction yielding said product; a plasma torch coupled to said chamber through an ingress port thereof that injects said feed material into said chamber; a first egress port comprising a

product collection port that receives the product; and a second egress port comprising an exhaust port that discharges waste and other by-products of said reaction.

[0021] Other embodiments are directed to a method for obtaining a Strategic Material such as a rare earth from a feed material, comprising processing a rare earth ore to obtain a corresponding rare earth metal oxide therefrom; mechanically pulverizing said rare earth oxide to a granular form; introducing said granular form of the rare earth oxide into a plasma reactor system; vaporizing said granular form of the rare earth oxide in said plasma reactor system to yield a vapor containing said rare earth oxide; introducing a hydrogen plasma into a reaction zone of said plasma reactor system where it can react with said vapor of rare earth oxide, reducing said rare earth oxide, and yielding a product and at least one waste by-product; and collecting said product by separating said product from said at least one waste by-product.

[0022] Yet other embodiments are directed to a system for processing a strategic material from an oxide thereof, comprising a reaction chamber capable of sustaining temperatures therein exceeding about 5,000 degrees Kelvin (K); feed material supply means that receives granular feed material including a strategic material oxide and injects said feed material into said reaction chamber; hydrogen supply means that injects hydrogen gas into said reaction chamber in a general direction opposing a general direction of said feed material; an induction heater that heats a reaction zone within said reaction chamber to a temperature of at least about 4,000 degrees Kelvin (K) and results in a hydrogen reduction reaction within said reaction zone between said hydrogen gas and said injected strategic material oxide to yield at least a strategic material product and a waste product; and collection means that receives said strategic material product.

BRIEF DESCRIPTION OF THE DRAWINGS

[0023] FIGS. 1-5 illustrate cross sectional views of exemplary plasma reactor systems;

[0024] FIG. 6 illustrates exemplary processes for extraction of a Strategic Material in a plasma reactor system; and

[0025] FIG. 7 illustrates an exemplary arrangement of two plasma processing devices to recover waste heat from a first one of such processing devices.

DETAILED DESCRIPTION

[0026] Rare earth elements (REEs) and other high value strategic materials are in increasing demand in a variety of industrial, military and other technological fields. Better techniques for extracting useful REEs from ore and mixed feed materials is needed. Also, new technologies for processing REEs and other high value strategic materials, e.g., for separating the metals from their ores and oxides, is required to meet this growing need. There is also a need for new technologies to further process the refined metals for improved alloys to reduce the cost and improve the performance of such products as batteries and high efficiency motors and generators. In some embodiments, the present systems provide improved mass resolution via the overall design configuration and aspect ratio, and control of the magnetic and electric field distributions.

[0027] Some embodiments hereof provide a plasma based system and method for making and employing the same, which is suitable for high-efficiency and economical production of useful product substances from ore or mixed feed

materials containing the useful products. Specifically, hydrogen direct reduction (HDR) of an ionized metal or rare earth oxide carried out at elevated temperatures in a plasma reactor chamber is described.

[0028] FIG. 1 illustrates an exemplary plasma reactor system 10 for processing feed materials to derive a useful product therefrom according to an embodiment. A reaction chamber 100 comprising a tank or shell body and a plurality of ports and auxiliary components is designed to contain the reactants in a reaction. A set of induction coils 120, which may surround all of or a portion of the body of reaction chamber 100, induce a radio frequency (RF) electromagnetic field in the chamber 100 to generate high temperatures therein. Magnetic field coils 130 generate a magnetic field in chamber 100 to cause movement of charged particles therein and/or confinement of ionized particles to spatially localize them in a region or regions within the interior volume of reaction chamber 100.

[0029] An inductively coupled plasma (ICP) torch 110 is disposed at or near one end of the reaction chamber 100 and fed by an auxiliary gas source 118. The ICP torch 110 is driven by coils of radio frequency (RF) coils 114 and may include magnetic confinement coils 124 generating a magnetic field within ICP torch 120. A feed material is injected at 125 into the ICP torch 110. An auxiliary gas 116 is also injected into the ICP torch in some embodiments.

[0030] A reaction zone 102 comprising a plasma discharge from the ICP torch 110 occupies some region within reaction chamber 100. In operation, the temperature in reaction chamber 100, and specifically in or near reaction zone 102 is raised to achieve a reaction to yield useful products collected at product collection discharge port 105 and water vapor at fluid discharge port 104, which can discharge water vapor, gas, entrained liquid and even solid particulates. In some aspects, any entrained remaining gases such as unreacted hydrogen or auxiliary gases escape through fluid discharge port 104 as well. In some embodiments, gravity pulls the collected material downwards and water vapor is discharged upwards.

[0031] FIG. 2 illustrates another embodiment of a plasma reactor system 20 including a reaction chamber 200 having walls substantially defining an interior volume and a reaction zone 210 therein. Energy is provided by induction coils 270 to ensure a desired reaction in the reaction zone 210. A confinement field generated by magnetic field coils 260 can confine or move or position charged particles inside reaction chamber 200.

[0032] A plasma torch 220 includes a carrier feed gas source 225 that brings mixed material such as a metal oxide or a rare earth metal oxide into the torch 220. A secondary or auxiliary gas 250 facilitates any of a favorable reaction, isolation of the external walls of torch 220 from reactants or heat within the torch 220, or other functions. The torch 220 is equipped with induction coils 222 and magnetic field coils 224 for heating and spatially confining the contents of torch 220.

[0033] One or more other plasma torches, e.g., hydrogen plasma torches 230 are provided as shown. The hydrogen plasma torches 230 also include their own induction coils 232, and optionally, magnetic field coils 234, and in some embodiments secondary or auxiliary gas feeds 236.

[0034] In operation, plasma system 20 creates an elevated temperature and causes a reaction involving a plasma from one or more plasma torches. The reactants can include particles of metal oxide from gas feed 225 and hydrogen so as to

result in a direct reduction to yield fluid (e.g., gas, vapors, steam, entrained liquid droplets) exiting from exhaust port 240 and product materials dropping into product collection port(s) 280. In some aspects, the density of the product material is greater than that of the reactants and other fluids in reaction zone 210 of reactor chamber 200. As a result, the products drop or precipitate out the bottom of the reactor chamber into collection ports to be collected for post-processing, packaging and use. An example of a reaction occurring in and around the reaction zone 210 includes:



[0035] where the reactants on the left hand side of the arrow are M_xO_y , representing a metal (M) oxide and H_2 representing hydrogen and the right hand side of the arrow includes water vapor H_2O and the desired metal product (M).

[0036] In some aspects, the hydrogen provided through hydrogen plasma torch(es) 230 is delivered at or about stoichiometric quantities relative to the gas feed 225. However, in other aspects comprehended herein, the hydrogen is delivered in substantially greater than stoichiometric amounts relative to the other reactants in the system. In a specific example, the hydrogen H_2 is available at 10% above the stoichiometric ratio. In another specific example, H_2 is provided at over 50% above the stoichiometric ratio. In yet another specific example, H_2 is provided at over twice the stoichiometric ratio. In these embodiments, excess H_2 is exhaust through outlet port 240 and is collected and reused, put to another purpose, or simply put to waste.

[0037] As an example, a rare earth metal oxide is fed 225 through plasma torch 220 combined with a hydrogen feed through plasma torches 230 may be raised to a temperature exceeding 4,000 degrees Kelvin (K) in some embodiments to cause the reduction reaction. Alternatively a temperature exceeding 4,500 K is employed in some embodiments, and in other embodiments a temperature exceeding 5,000 K is employed for this purpose.

[0038] Generally, for most present applications, the design of the system and method of operation provides temperatures in the reaction zone of a plasma reactor system ranging between about 5,000 K to 15,000 K, or between about 0.4 electron volts (eV) to 13 eV. The use of the described plasma torches and the induction coils permits operation at such elevated temperatures, which were hitherto unattainable in the prior art. Specifically, the prior art would not be capable of attaining energetic ionized states of (e.g.) hydrogen in a reactor and as such would fail to produce the desired reactions described herein. The present systems and methods can achieve such temperatures and energy levels to support reactions to yield various useful materials including metals and rare earth substances, including: tantalum (Ta), neodymium (Nd), dysprosium (Dy), lanthanum (La), and samarium (Sm). Other metals and rare earth substances can also be extracted using the present methods and systems and those examples would be or become clear to one skilled in the art upon reading the present disclosure. In an example, a direct hydrogen reduction equation yielding a tantalum product is:



[0039] In an aspect, the present plasma reactor systems are design and configured to take advantage of fluid dynamic features that more optimally promote production of the useful products therefrom. Some embodiments are designed to maximize or increase the contact between the reactants in the reaction zone(s) of a reactor chamber (there may be more than

one such zone). Specifically, some embodiments are designed to provide reactants (e.g., ionized metal oxides, hydrogen of Equation 1) along fluid flow paths within the reactor chamber so as to increase a time and/or quality of interaction between the reactants. More specifically, the fluid flow paths can be arranged in co-flow, cross-flow or counter-flow scenarios so that the bulk of the main reactants (metal oxide and hydrogen) are moving in the same general direction, or across one another's path, or generally in opposite directions, respectively. These flow paths can be arranged to benefit the production of useful product materials from the plasma reactor systems. In an aspect, a differential density of reactants and/or products can be exploited so that the force of gravity acting downward on small particles or droplets in the reaction zone is counteracted by an upward fluid entrainment effect from upwardly flowing fluid. The result is that the particles or droplets remain suspended in the reaction zone, delaying their dropping to the bottom of the reaction chamber, for a longer period of time. Also, in some aspects, the reactant particles or droplets are allowed to geometrically reconfigure their shapes and sizes over time so as to favorably affect the outcome of the reaction in the chamber. For example, larger irregular reactants, held in the reaction zone for longer durations, will be allowed to shrink in size and take on more spherical profiles before exiting the reactor.

[0040] FIG. 3 illustrates a plasma reactor system 30 having a containment vessel or reaction chamber 300 as previously described and induction coils 320 and magnetic field coils 330 as before. The embodiment shown is a counter-flow scenario in which reactants (e.g., a metal oxide ore product) 32 enters the top of the chamber 300 through a plasma torch 310. Reactants 32 enter the reaction zone of the system with a given size and shape distribution that is relatively large and irregular (not smooth). Near the bottom of reactor chamber 300 are one or more plasma torches 340 injecting hydrogen 342 (an optionally a sheath or auxiliary gas 344).

[0041] As can be seen, the general travel path of the injected feed substance 32 is downward and the general direction of flow of hydrogen is upward from its source 342, into a lower portion of the chamber 370, up through a middle portion of the chamber 372 and reaction zone, and on to an upper portion of the chamber 374 where any excess hydrogen, reaction gaseous or vapor fluid emissions are discharged from ports 302. Since the reactants interact in the reaction zone, the extra time in flight for the metal oxide-to-metal material descending through the chamber results in increased reaction between the reactants, and greater production of (e.g., metal) product 34 dropping into collection port 350 for collection in a collection vessel 360.

[0042] Various mechanisms including convection, Brownian motion, laminar flow, turbulent flow, thermal and chemical effects, and other factors determine the amount of reactant and product yield of the system 30 in operation and the amount of time reactant particles or droplets remain in the reaction zone. The present system and methods are designed, in some embodiments, to allow the descending materials, especially near or in the reaction zone and around the central zones 372 of chamber 300, to substantially achieve a "terminal velocity" with respect to the rising gases coming up from plasma torches 340 from areas 370 below in the chamber 300. In such a situation, depending on the shape and size of the descending product material, and depending on the differential density between the product and the other reactants, the

system's operation can be optimized for best production of product in and around the reaction zone of the chamber 300.

[0043] In some aspects, the present system is designed and configured to meter the rate of flow and the velocity of the fluids in the reactor system 30, including so that the rate of falling or dropping of the product metal under the force of gravity is somewhat or completely offset by the upward draft of the gases in the counter-flow fluid dynamic scenario. Also, co-flowing and cross-flow scenarios can be designed to take advantage of the drag (friction) of the fluids within the reactor chamber so as to buoy or suspend or keep the products and reactant materials in residence in the reaction zones for an effective period of time, increasing production.

[0044] FIG. 4 illustrates a simplified plasma reactor system 40 including a reaction chamber 400 wherein a plurality of reactants are introduced and react under elevated thermal conditions. In or about a reaction zone 410 of said chamber a counter-flow of downwardly flowing feed reactants 420 mixes with and reacts with upward flowing gas reactant 430 (e.g., hydrogen). The reactants are preferably provided from plasma torch assemblies coupled to various ingress ports of the system 40. An egress or exhaust discharge port allows waste and excess by-products 450 of the reaction to exit from the chamber. In some embodiments, a sheath gas or auxiliary gas 440 is provided into the chamber 400, and which also flows up and out of the chamber at the designed rate. Any produced product material, such as metal, will drop downwards by force of gravity to a portion of the reactor near its bottom, which is eventually collected and discharged through a discharge port or collection assembly. In some embodiments, a plurality of processes are arranged so that waste heat of the energetic exhaust fluids is recovered and used in a subsequent process or step as will be described below.

[0045] FIG. 5 illustrates another embodiment of a plasma reactor system 50. The system includes a reaction chamber 500 as before. Also, the system feeds a feed material 505 through a plasma torch such as an ICP into a reaction zone 510 of reactor chamber 500. Hydrogen 530 is fed in by one or more hydrogen plasma torches to react with the feed material 505 in the reaction zone 510. Here, the feed material 505 and hydrogen gases 530 are introduced into the reactor 500 having generally a same flow direction (e.g., upwardly). But the reaction yielding a product that is heavier than the other substances in the reactor will drop towards the reactor's bottom by the force of gravity. Nonetheless, during reaction, a residence time is designed such that droplets, particles or small pieces of the product can become well reacted and even spheroidized in the chamber 500 before they drop out and are collected. Again, a secondary or sheath gas 540 or further reacting fluids (e.g., hydrogen) can be introduced through ports in the walls of the chamber 500 as necessary or desired.

[0046] In all, it can be seen from the previous discussion how a system is designed to maximize the reaction in a plasma reactor system. In some aspects this is accomplished in carefully designing the fluid dynamic pathways and flow rates in view of the different densities of the reactants and products to encourage good residence time in the reaction zone or zones of the reactor. A balanced system in operation can seem to levitate or buoy the reactants (e.g., a metal oxide) while it reacts so as to produce a heavier (e.g., metal) product that falls due to its greater weight (gravitational force acting on the mass of the metal product). Furthermore, as the reactants and product materials undergo changes in the hot reactor systems, the shapes and sizes of droplets and particles thereof

may be customized to a desired size and form. Ideally, the product will drop down into the lower collection chutes and outlet ports just at the right level of reaction and particle shape and size to be useful.

[0047] FIG. 6 illustrates a simplified exemplary process or method for producing a product (e.g., a rare earth metal) from a mixed feed material (e.g., a rare earth metal oxide) in a plasma reactor system like those shown previously.

[0048] A rare earth ore is provided at step 600. The ore is processed, for example using a beneficiation step, crushed, and optionally mixed with other substances to remove gangue (dirt) and collect a useful mineral (e.g., a rare earth metal oxide) in solid form at 602. The metal oxide is pulverized at 604 to a form fine enough to feed into an ICP plasma torch at 606.

[0049] As discussed above, the fine rare earth metal oxide is fed into the torch and vaporized at 608 to produce an ionized fluid containing the oxide. A hydrogen gas (optionally a hydrogen plasma) is introduced at 610 to react with the metal oxide in a reactor.

[0050] The reaction (e.g., a direct hydrogen reduction) at 612 proceeds as described earlier to yield a product (e.g., a rare earth metal) that is collected at 614. Also, waste and other excess exhausted materials (e.g., hydrogen gas, water vapor) are ejected at 618, or optionally directed for recycling or for reclamation of their excess thermal energy in a subsequent process. The collected product is post processed at step 616. The post-processing may include further heating to drive off excess hydrogen and contaminants and may include, cleaning, agitating in a vacuum, spherodizing, inert gas storage, or other steps.

[0051] FIG. 7 illustrates a way for recovering heat from multiple plasma reactor systems like those discussed above. In an embodiment, a first plasma reactor system 700 receiving a feed 701 into a plasma torch (e.g., ICP torch) 702. A second stream of fluid 720 is input as shown and exchanges thermal energy (is heated) from the hot discharge 730 of the first plasma reactor system 700. In a simplified example the exchange of heat from fluids 730 to 720 is carried out in a counter-flow heat exchanger, but others are possible (co-flow and cross-flow, radiators, etc.)

[0052] The heated fluid 720 is introduced as a feed 740 into a second plasma reactor system 710 in a plasma torch 712, coupled with a gas (e.g., hydrogen) 714, and that exhausts at 716. It should be appreciated that multiple systems like that described can be arranged in series and/or parallel to form a larger system with greater capacity.

[0053] Also, it should be appreciated that a single plasma system can re-circulate its hot waste vapour, gas and exhaust back into a stream that exchanges heat with input feed materials so as to preheat the feed materials and recover otherwise wasted heat energy.

[0054] The present invention should not be considered limited to the particular embodiments described above. Various modifications, equivalent processes, as well as numerous structures to which the present invention may be applicable, will be readily apparent to those skilled in the art to which the present invention is directed upon review of the present disclosure.

What is claimed is:

1. A plasma reactor system for extracting a product from a feed material, comprising:

- a reaction chamber having walls substantially defining an enclosed volume of said chamber including at least one reaction zone;
 - a plurality of ports for ingress and egress of materials into and out of said chamber;
 - a set of induction coils that generates temperatures within said reaction zone to cause a reaction yielding said product;
 - a plasma torch coupled to said chamber through an ingress port thereof that injects said feed material into said chamber;
 - a first egress port comprising a product collection port that receives the product; and
 - a second egress port comprising an exhaust port that discharges waste and other by-products of said reaction.
2. The system of claim 1, further comprising a set of magnetic field coils that spatially confine charged particles to one or more portions of said enclosed volume.
3. The system of claim 1, said plasma torch comprising an inductively coupled plasma (ICP) torch fed by a carrier gas containing said feed material.
4. The system of claim 3, said plasma torch further comprising an auxiliary gas feed injecting an auxiliary gas into said torch.
5. The system of claim 3, further comprising a magnetic field coil disposed about said plasma torch that provides a magnetic field within a body of said torch.
6. The system of claim 1, further comprising a hydrogen plasma torch, coupled to said chamber, that injects a hydrogen supply into said chamber so as to cause a reduction reaction within said reaction zone.
7. The system of claim 1, said second egress port designed and configured to eject water vapor from said chamber to a place external to said chamber.
8. The system of claim 1, said product collection port designed and configured to collect and discharge said product substance from said chamber.
9. The system of claim 1, said first egress port disposed lower in said chamber than said second egress port so that the system can use gravitational force to discharge said products downwardly towards said first egress port and to discharge said waste by-products upwardly towards said second egress port.
10. The system of claim 1, said induction coils designed and configured to cause a temperature within said reaction zone exceeding about 4,000 degrees Kelvin (K).
11. The system of claim 1, further comprising at least one hydrogen plasma torch providing a hydrogen gas supply into said chamber, and wherein said carrier gas feed and said hydrogen gas supply are directed into the chamber in generally opposing directions, i.e., in a counter-flowing configuration.
12. The system of claim 11, wherein said plasma torch provides the feed gas material in a first general direction at a first design flow rate, and said hydrogen plasma torch provides the hydrogen gas in a second general direction at a second designed flow rate metered to offset a rate of dropping of said product through the enclosed volume of the chamber through hydrodynamic effects of said counter-flow.
13. The system of claim 12, said first general direction of the feed gas material being generally downward and said second general direction being generally upward so that the rate of dropping of said product downward due to gravita-

tional force is retarded by an upward draft of said hydrogen gas and other fluids moving upwardly through said chamber.

14. The system of claim **13**, configured and designed so that said first and second directions and flow rates substantially achieve a terminal velocity of falling droplets of a given size of said product within the upwardly streaming fluids in said chamber, thereby increasing a residence time of said droplets within the chamber.

15. The system of claim **14**, configured and designed so as to permit dropping of said product towards said collection port based on a difference in density of said product and said feed material where said product has a greater density than said feed material.

16. The system of claim **12**, said second design flow rate providing hydrogen in excess of a stoichiometric requirement for reaction with said feed material.

17. The system of claim **1**, further comprising a quartz shield disposed between said plasma torch and other components of the system to protect the latter from effects of excessive temperatures caused by said torch.

18. The system of claim **1**, said auxiliary gas comprising a sheath gas that coats a surface of said torch and chamber.

19. The system of claim **1**, said feed material comprising a metal oxide and said product comprising a metal.

20. The system of claim **19**, said metal oxide comprising a rare earth metal oxide and said product comprising a rare earth metal.

21. The system of claim **20**, said rare earth metal oxide comprising any of: a tantalum oxide, a neodymium oxide, a lanthanum oxide and a samarium oxide, and said product comprising any of: tantalum, neodymium, lanthanum and samarium.

22. The system of claim **1**, at least a portion of said chamber comprising a decreasing area cross sectional profile so as to create a correspondingly increasing fluid flow velocity within said chamber.

23. The system of claim **1**, further comprising a heat exchanger that receives a hot discharge from said second egress port which is used to preheat a substance entering a second process so that at least some heat energy from the discharge of said second egress port is recovered in said second process.

24. The system of claim **1**, said feed gas material comprising finely divided metal oxide substance injected into said plasma torch.

25. A method for obtaining a strategic material such as a rare earth from a feed material, comprising:

- processing a rare earth ore to obtain a corresponding strategic material oxide therefrom;
- mechanically pulverizing said strategic material oxide to a granular form;
- introducing said granular form of the strategic material oxide into a plasma reactor system;
- vaporizing said granular form of the strategic material oxide in said plasma reactor system to yield a vapor containing said strategic material oxide;
- introducing a hydrogen plasma into a reaction zone of said plasma reactor system where it can react with said vapor of strategic material oxide, reducing said strategic material oxide, and yielding a product and at least one waste by-product; and
- collecting said product by separating said product from said at least one waste by-product.

26. The method of claim **25**, further comprising heating said reaction zone to at least 4,000 degrees Kelvin (K) using a set of induction coils.

27. The method of claim **25**, further comprising collecting said waste by-product and extracting heat energy therefrom in a heat exchange step of another process.

28. The method of claim **25**, further comprising post-processing said collected product.

29. The method of claim **28**, comprising heating said collected product to drive off residual hydrogen or other contaminants.

30. The method of claim **25**, further comprising fluidizing said product in said chamber.

31. The method of claim **25**, introducing said hydrogen plasma comprising providing a gaseous form of hydrogen at a flow rate and in a direction generally opposing a direction of movement of said oxide in said reaction zone.

32. The method of claim **31**, said flow rate and direction of said hydrogen being provided so as to substantially overcome a downward force of gravity on said oxide in said reaction zone by an upward force due to the hydrogen's upward flow, and so as not to overcome a downward force of gravity on said product, which is allowed to descend to a designated collection point.

33. The method of claim **25**, further comprising heating said reaction zone by way of an induction coil.

34. The method of claim **33**, said heating raising a temperature within said reaction zone to a range between 4,000 and 15,000 degrees Kelvin (K).

35. The method of claim **25**, further comprising a step of particle size classification to classify various contents of said system according to their size, and acting on said particles based on said size.

36. The method of claim **35**, further comprising providing said hydrogen at a variable flow velocity to counteract motion of said particles of a given size.

37. A system for processing a strategic material from an oxide thereof, comprising:

- a reaction chamber capable of sustaining temperatures therein exceeding about 5,000 degrees Kelvin (K);
- feed material supply means that receives granular feed material including a strategic material oxide and injects said feed material into said reaction chamber;
- hydrogen supply means that injects hydrogen gas into said reaction chamber in a general direction opposing a general direction of said feed material;
- an induction heater that heats a reaction zone within said reaction chamber to a temperature of at least about 4,000 degrees Kelvin (K) and results in a hydrogen reduction reaction within said reaction zone between said hydrogen gas and said injected strategic material oxide to yield at least a strategic material product and a waste product; and
- collection means that receives said strategic material product.

38. The system of claim **37**, further comprising a liquid product receptacle for receiving said strategic material product in a liquid form.

39. The system of claim **37**, further comprising a solid product receptacle for receiving said strategic material product in a solid form.

40. The system of claim **37**, further comprising a plasma torch for ionizing said strategic material oxide.

41. The system of claim **37**, further comprising a plasma torch for ionizing said hydrogen.