

US 20130105304A1

(19) **United States**

(12) **Patent Application Publication**  
**Kaczur et al.**

(10) **Pub. No.: US 2013/0105304 A1**

(43) **Pub. Date: May 2, 2013**

(54) **SYSTEM AND HIGH SURFACE AREA ELECTRODES FOR THE ELECTROCHEMICAL REDUCTION OF CARBON DIOXIDE**

filed on Sep. 19, 2012, provisional application No. 61/703,187, filed on Sep. 19, 2012, provisional application No. 61/720,670, filed on Oct. 31, 2012, provisional application No. 61/703,229, filed on Sep. 19, 2012, provisional application No. 61/675,938, filed on Jul. 26, 2012.

(71) Applicant: **Liquid Light, Inc.**, Monmouth Junction, NJ (US)

**Publication Classification**

(72) Inventors: **Jerry J. Kaczur**, North Miami Beach, FL (US); **Theodore J. Kramer**, New York, NY (US); **Paul Masztrik**, Cranbury, NJ (US); **Kunttal Keyshar**, Santa Clara, CA (US); **Zbigniew Twardowski**, Burnaby (CA)

(51) **Int. Cl.**  
**C25B 11/04** (2006.01)  
**C25B 9/10** (2006.01)

(73) Assignee: **LIQUID LIGHT, INC.**, Monmouth Junction, NJ (US)

(52) **U.S. Cl.**  
CPC ..... **C25B 11/0478** (2013.01); **C25B 9/10** (2013.01)  
USPC ..... **204/237**; 204/242; 204/252; 204/267; 204/253; 204/290.01; 204/290.03

(21) Appl. No.: **13/724,988**

(57) **ABSTRACT**

(22) Filed: **Dec. 21, 2012**

**Related U.S. Application Data**

(60) Provisional application No. 61/701,237, filed on Sep. 14, 2012, provisional application No. 61/703,158, filed on Sep. 19, 2012, provisional application No. 61/703,175, filed on Sep. 19, 2012, provisional application No. 61/703,231, filed on Sep. 19, 2012, provisional application No. 61/703,232, filed on Sep. 19, 2012, provisional application No. 61/703,234, filed on Sep. 19, 2012, provisional application No. 61/703,238, filed on Sep. 19, 2012, provisional application No. 61/703,238,

Methods and systems for electrochemical conversion of carbon dioxide to organic products including formate and formic acid are provided. A system may include an electrochemical cell including a cathode compartment containing a high surface area cathode and a bicarbonate-based catholyte saturated with carbon dioxide. The high surface area cathode may include an indium coating and having a void volume of between about 30% to 98. The system may also include an anode compartment containing an anode and an acidic anolyte. The electrochemical cell may be configured to produce a product stream upon application of an electrical potential between the anode and the cathode.

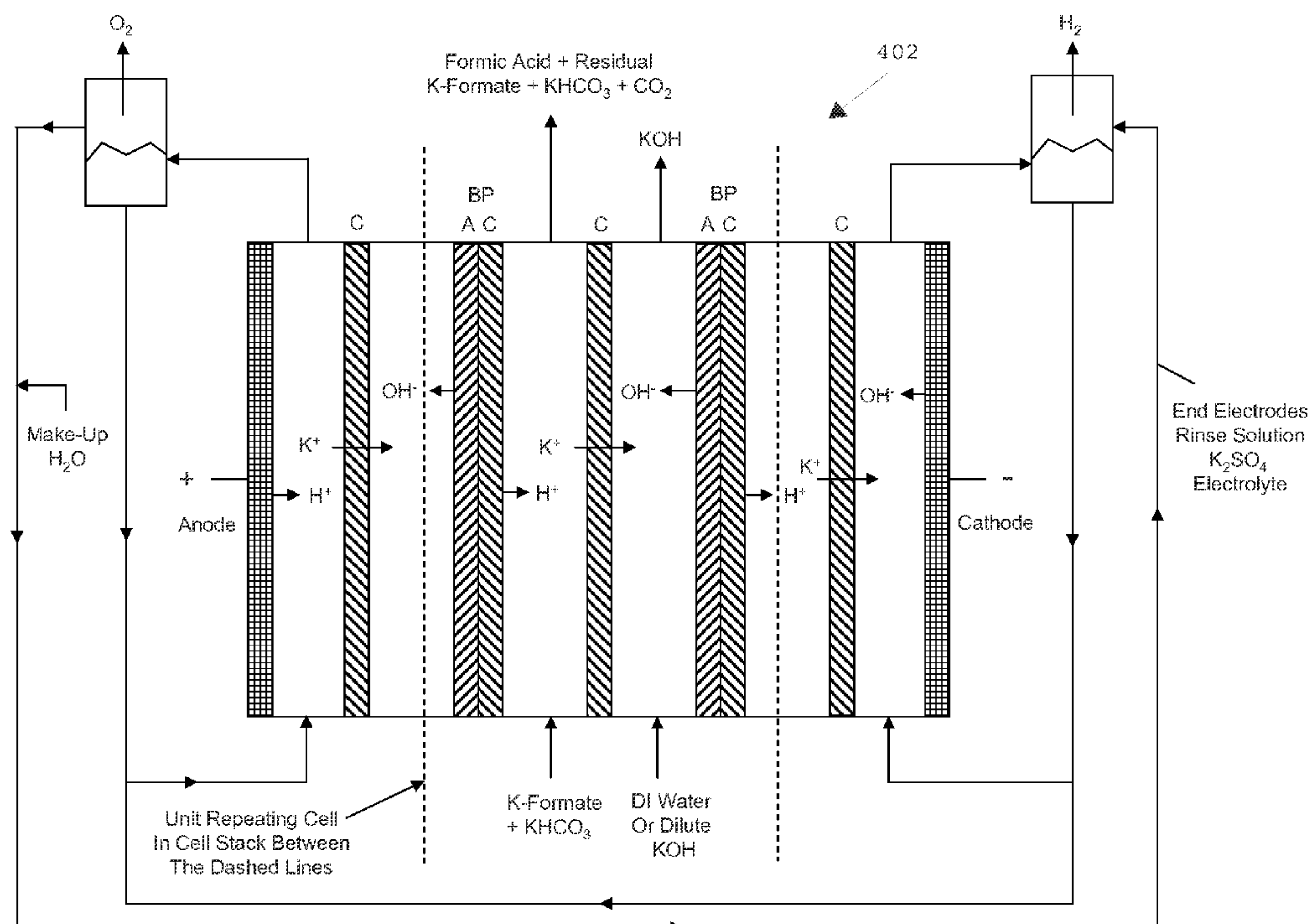

BP: Bipolar Membrane  
C: Cation Exchange Membrane  
A: Anion Exchange Membrane

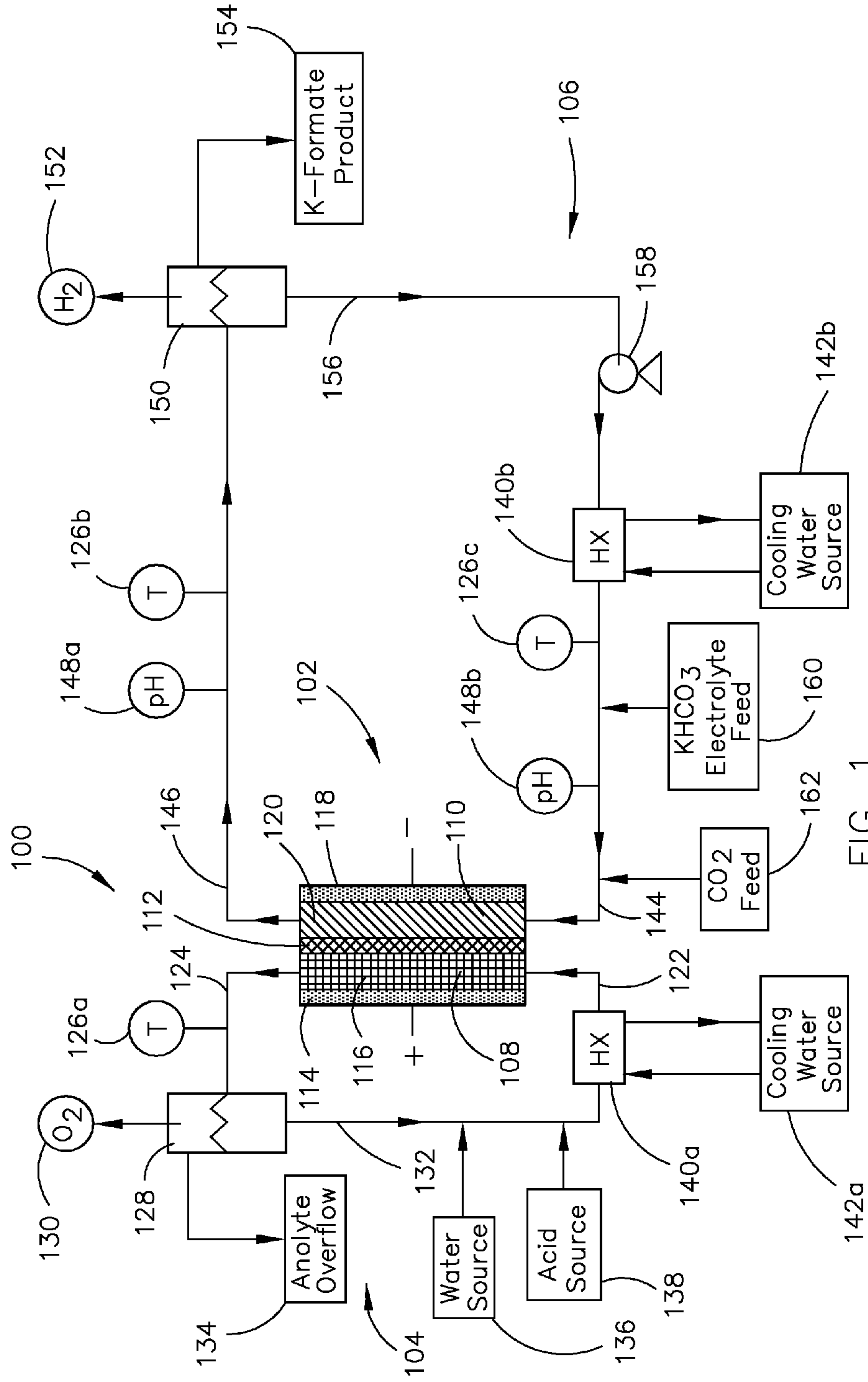

FIG. 1

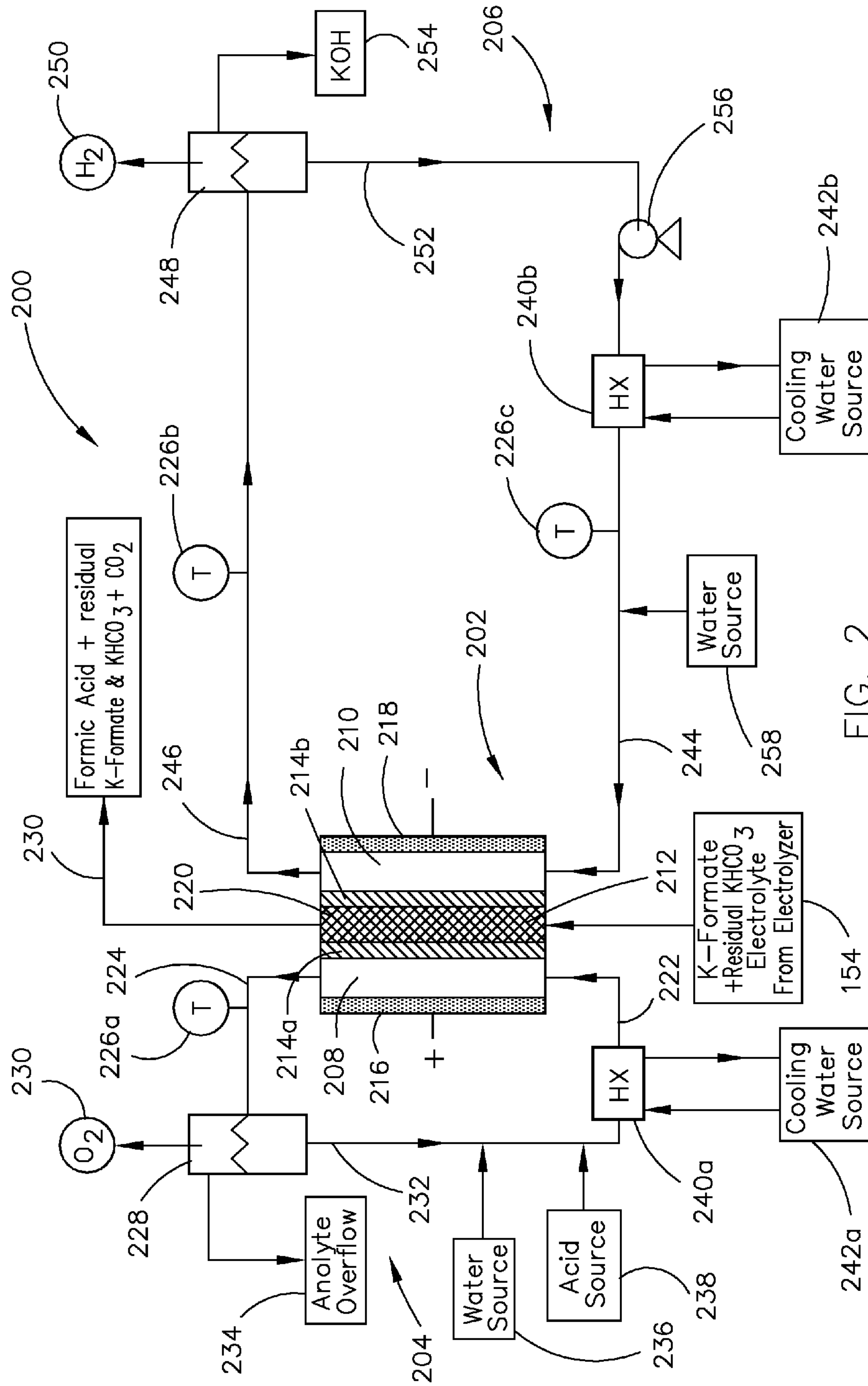

FIG. 2

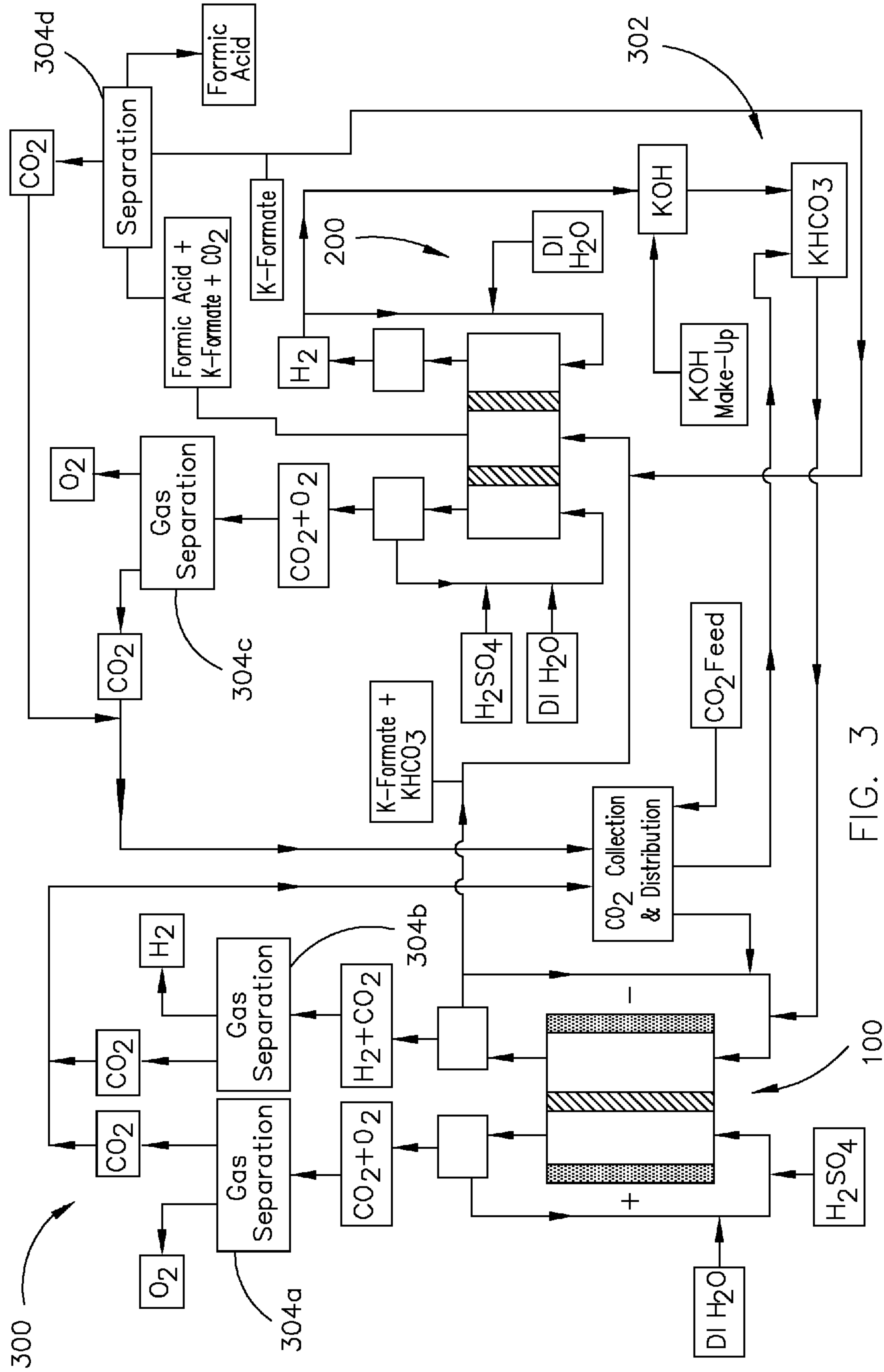

FIG. 3

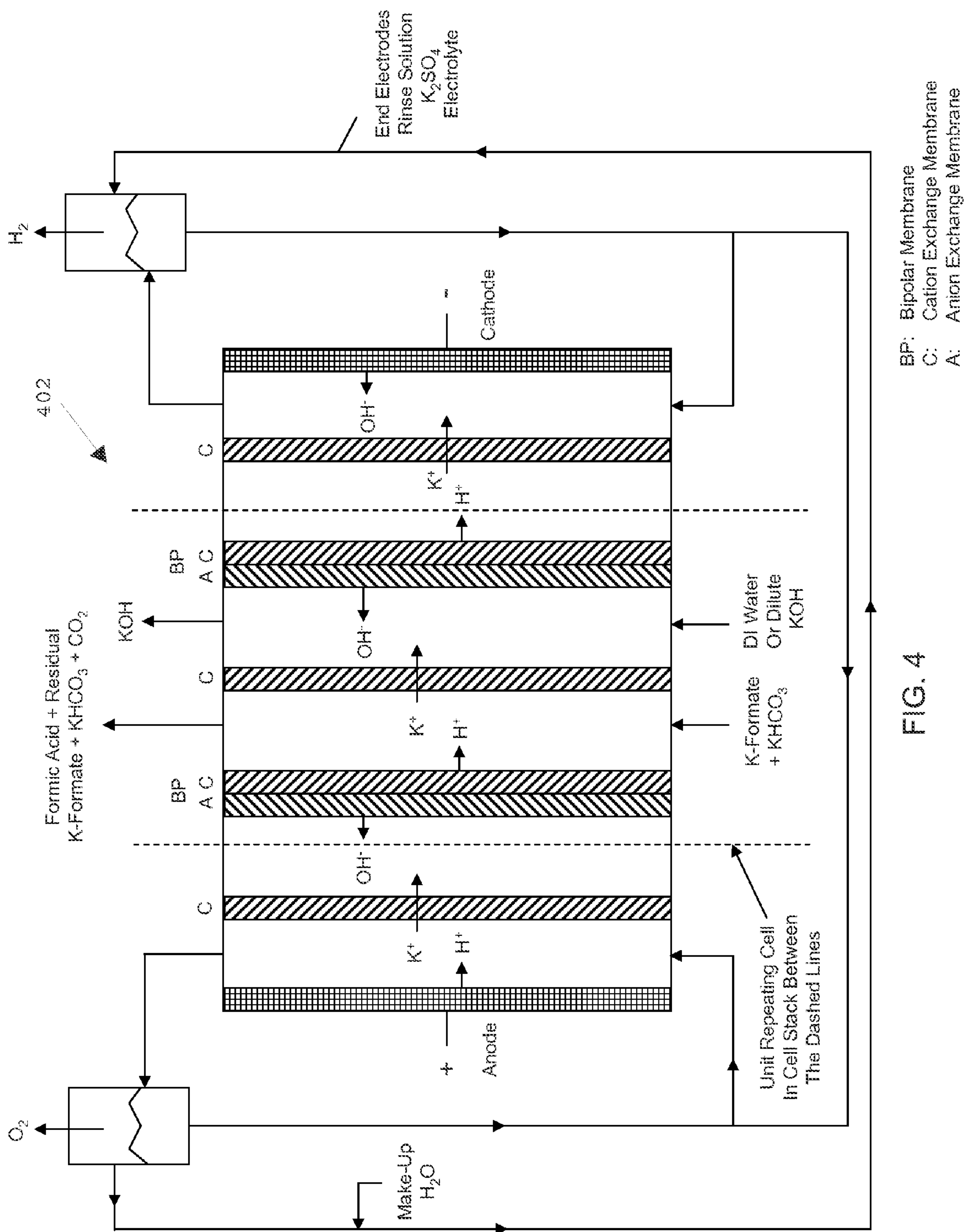

FIG. 4



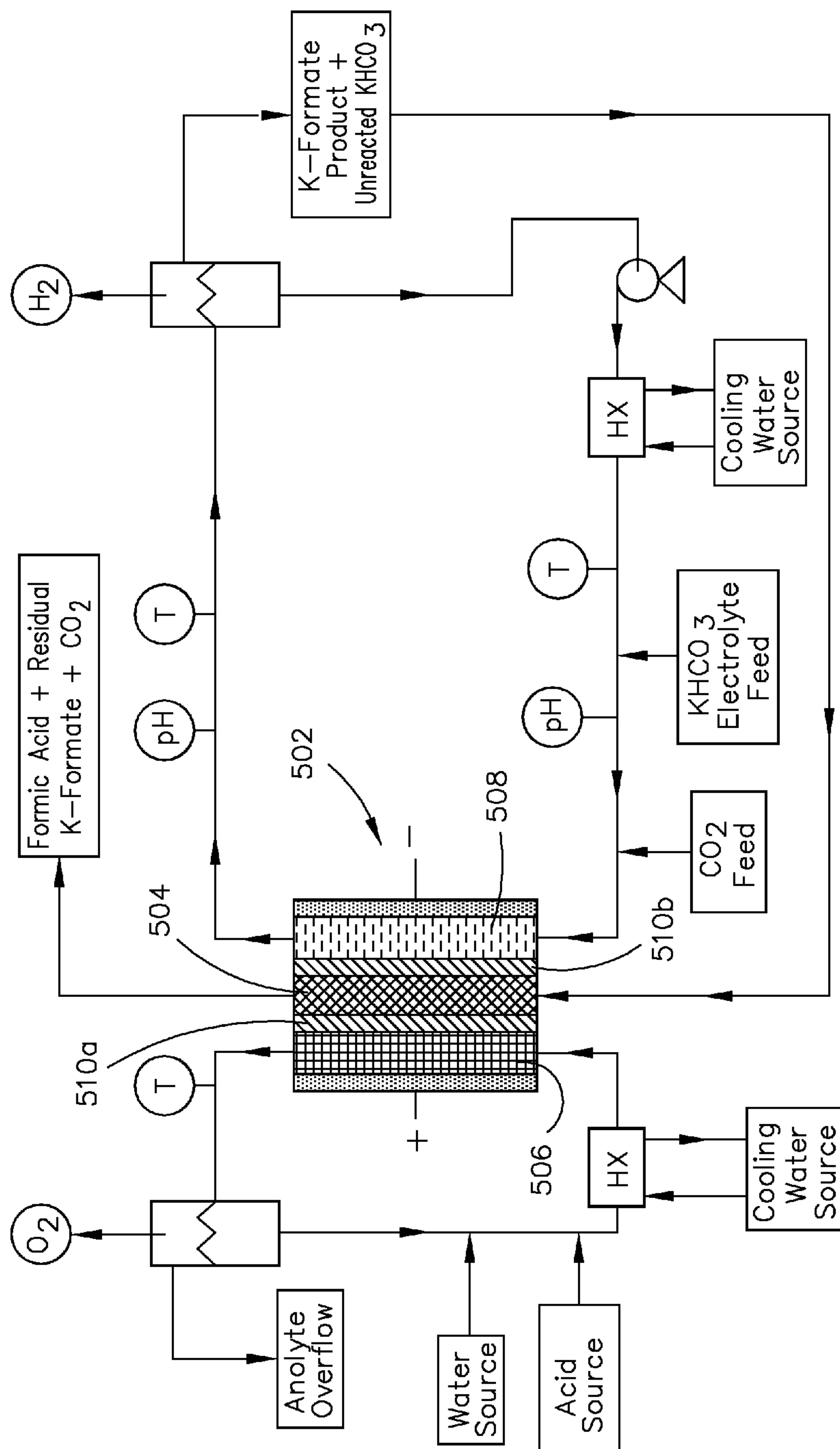

FIG. 5

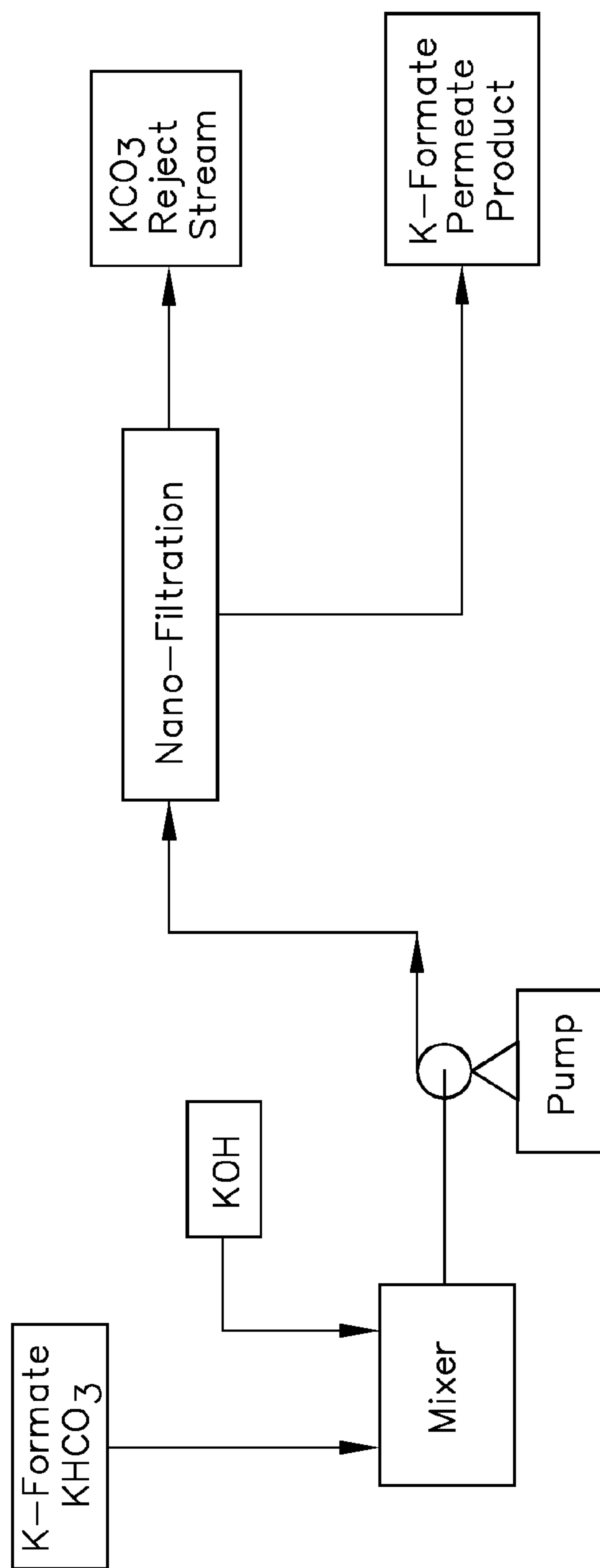

FIG. 6

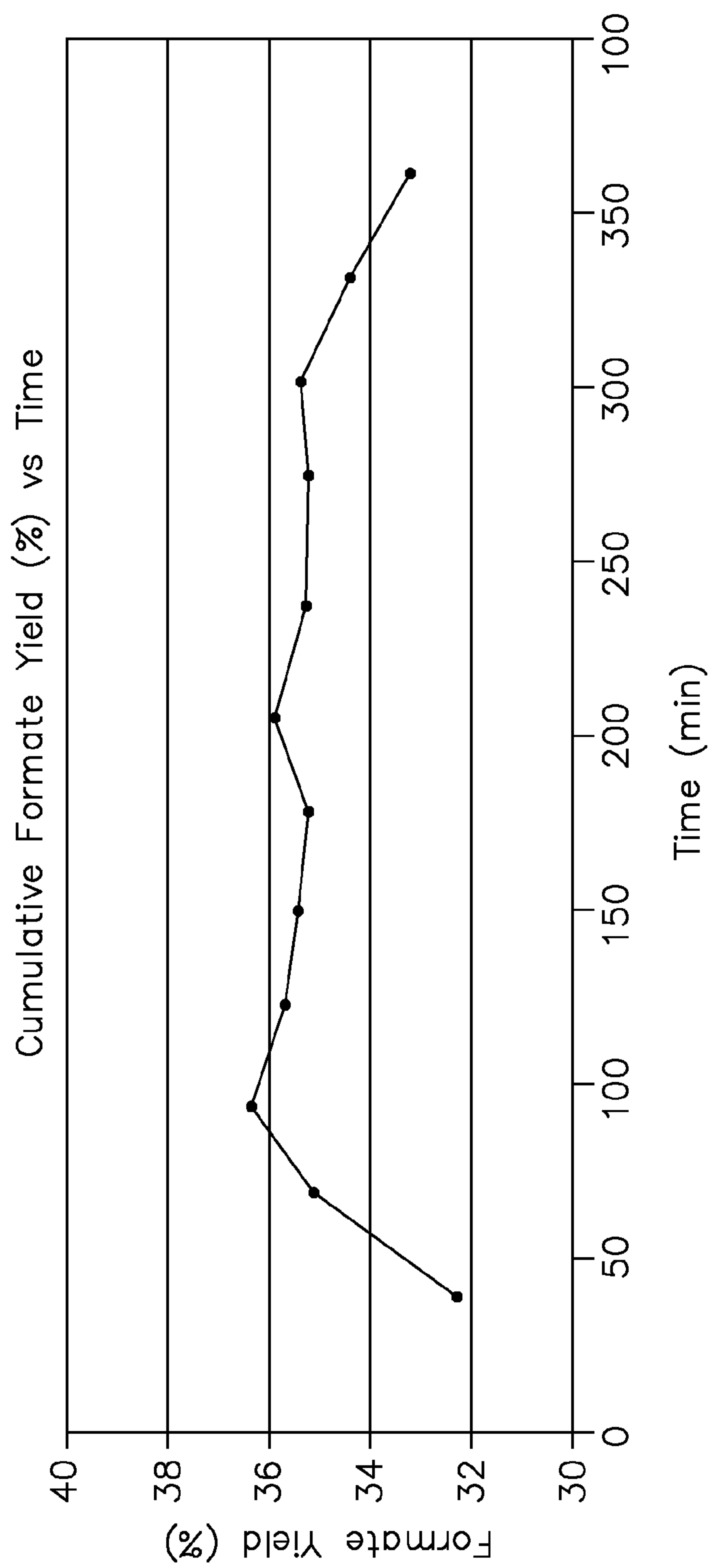

FIG. 7



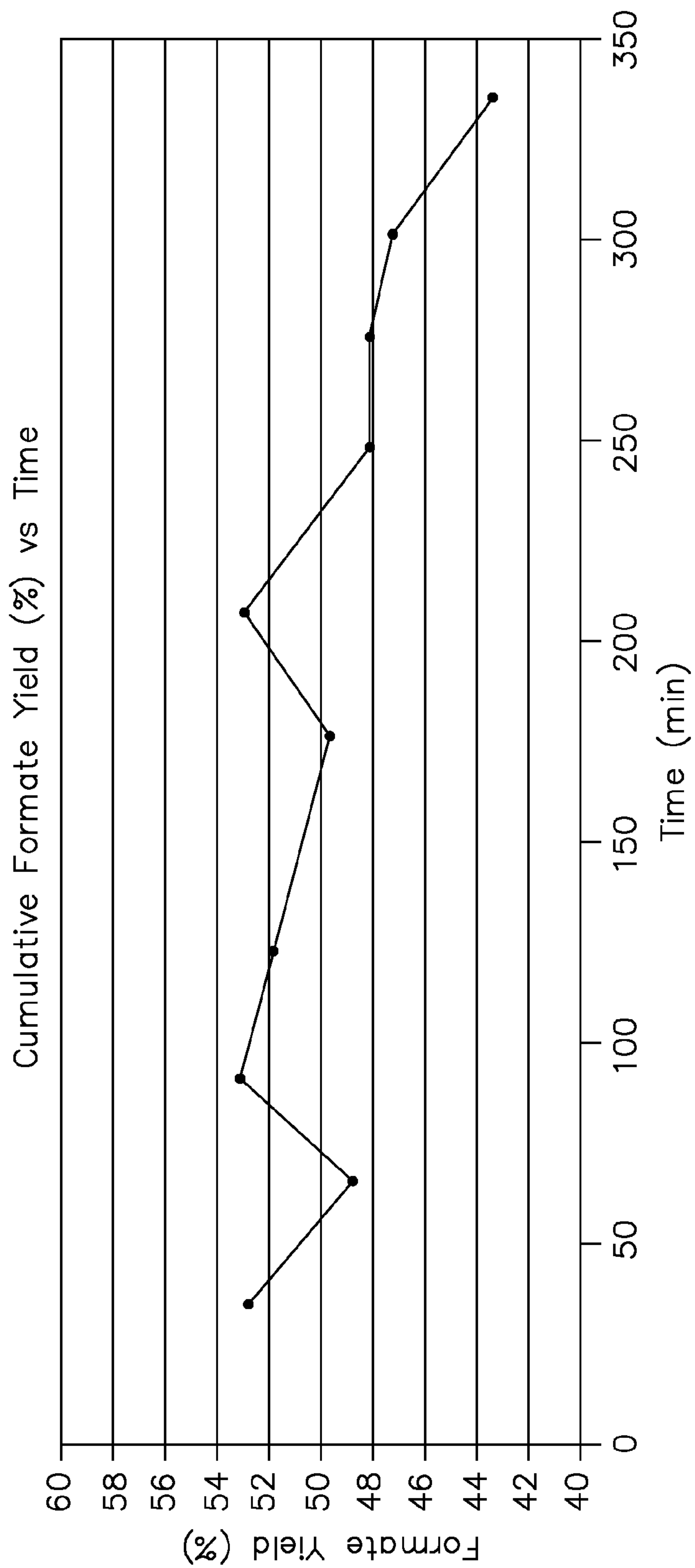

FIG. 8

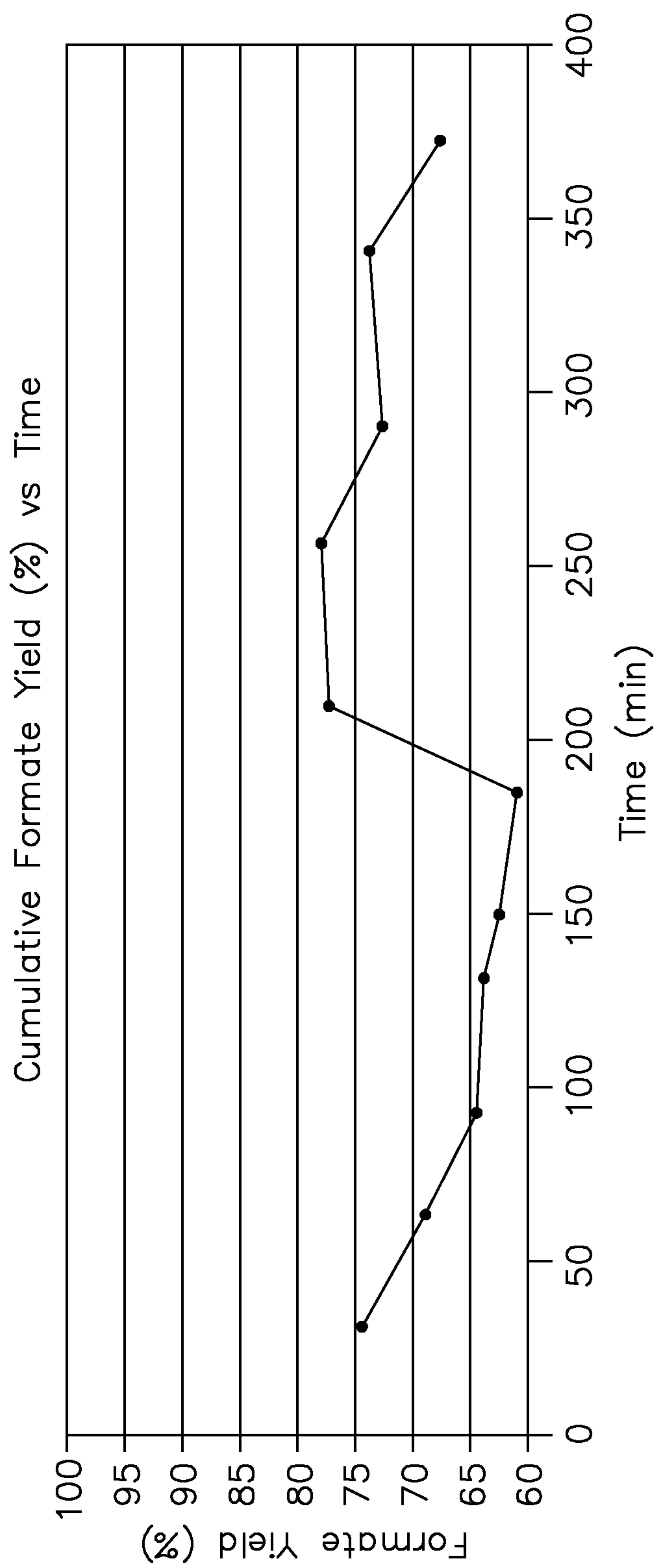

FIG. 9

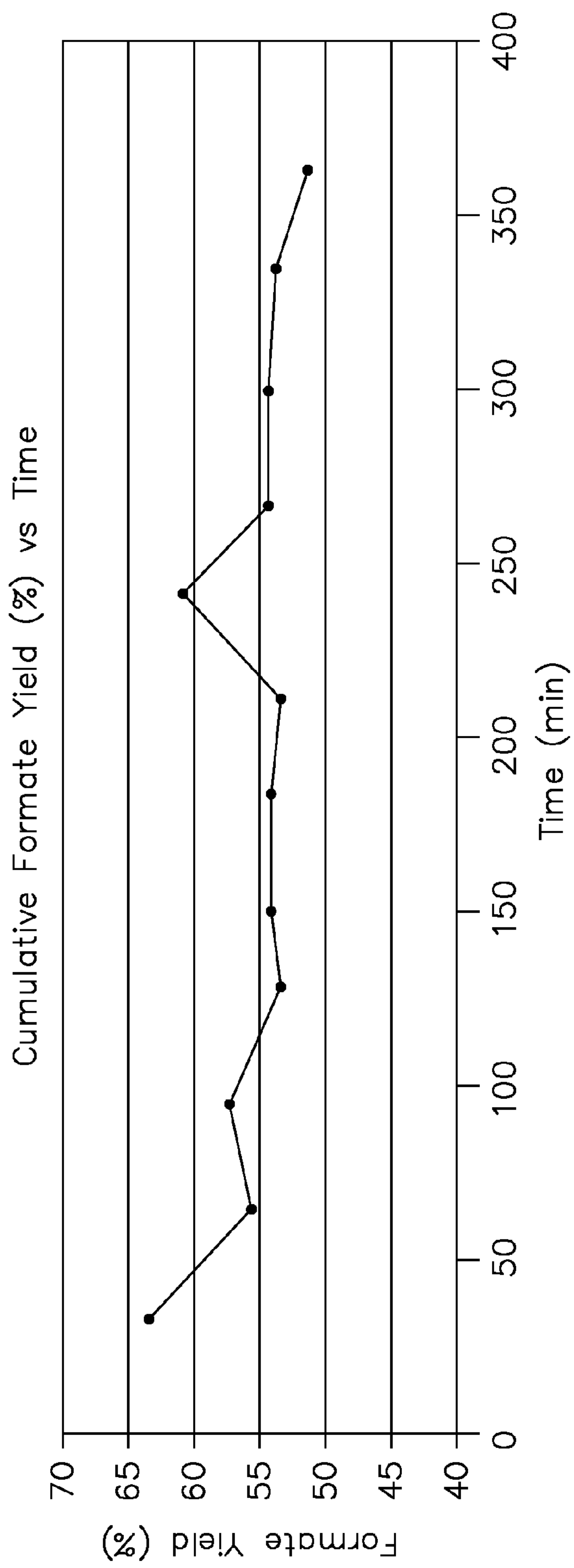

FIG. 10

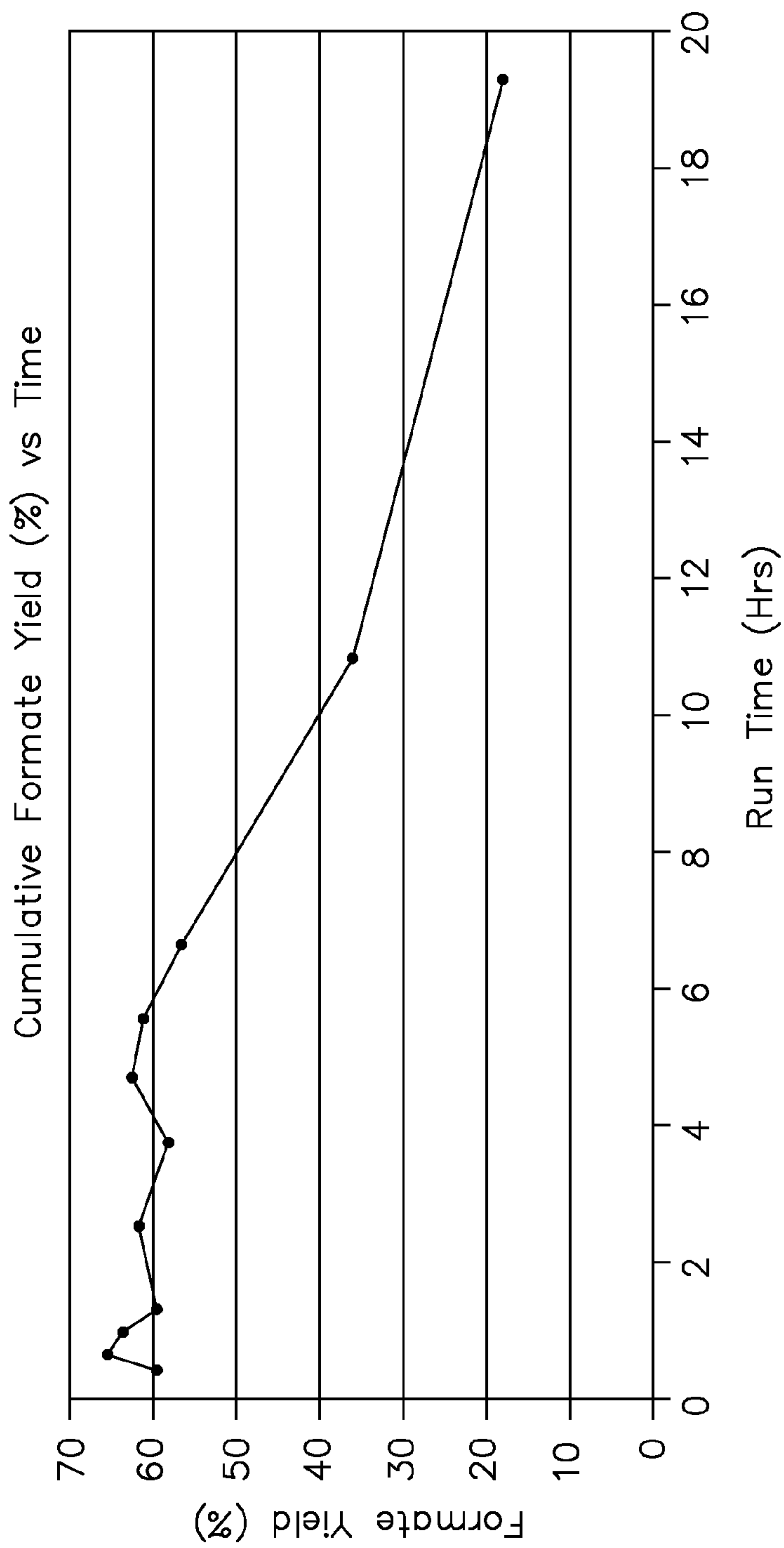

FIG. 11

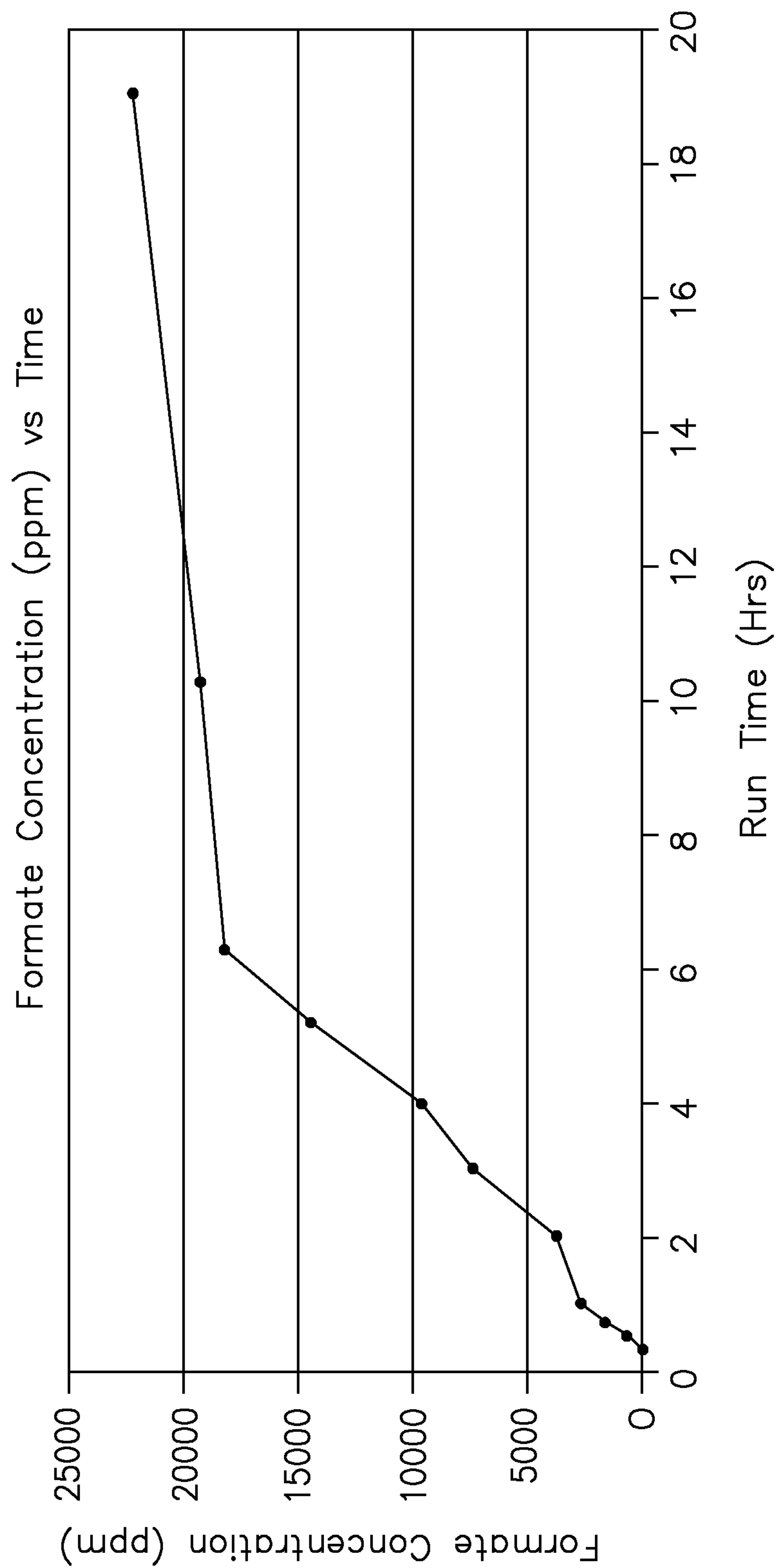

FIG. 12

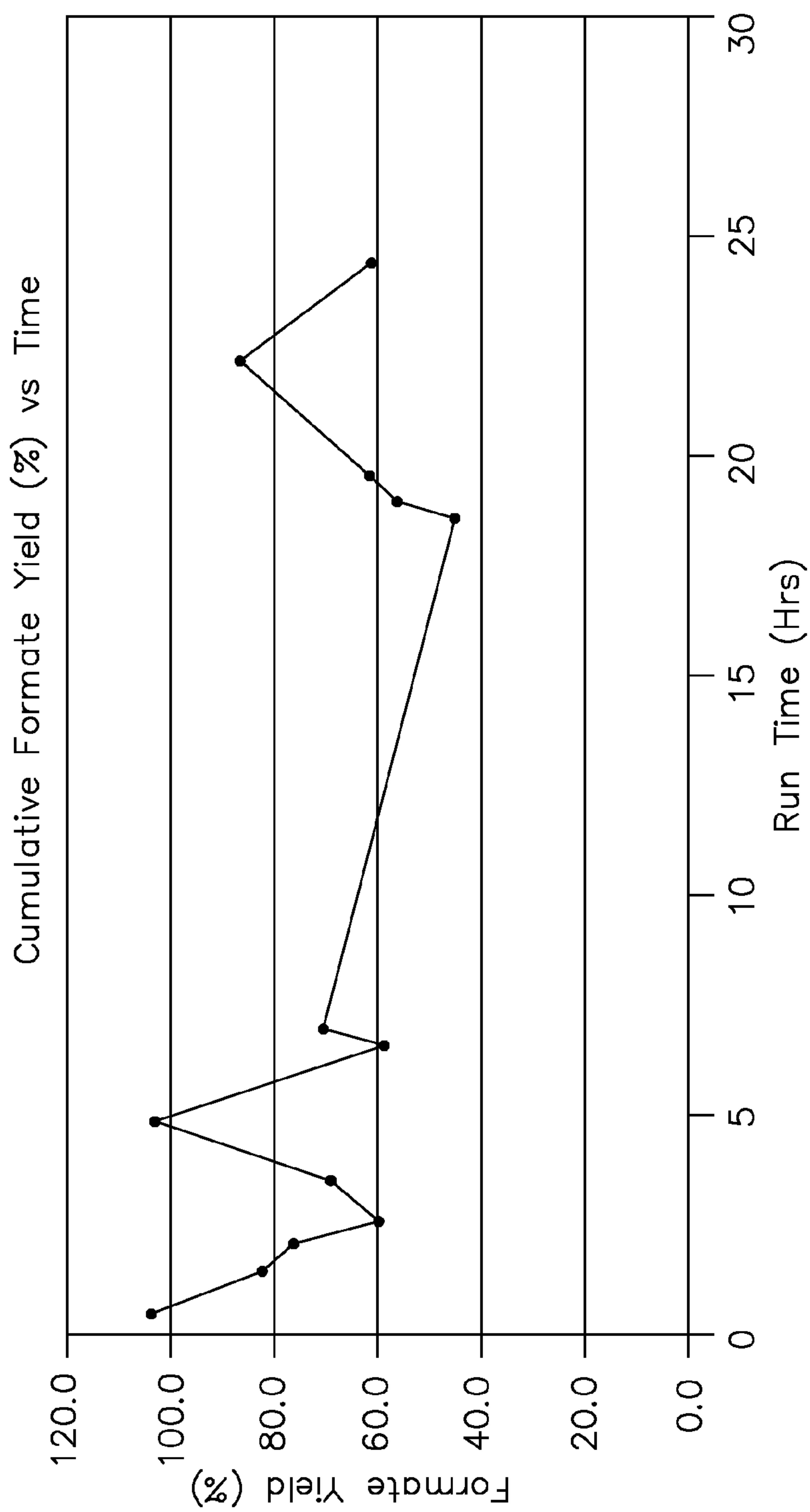

FIG. 13



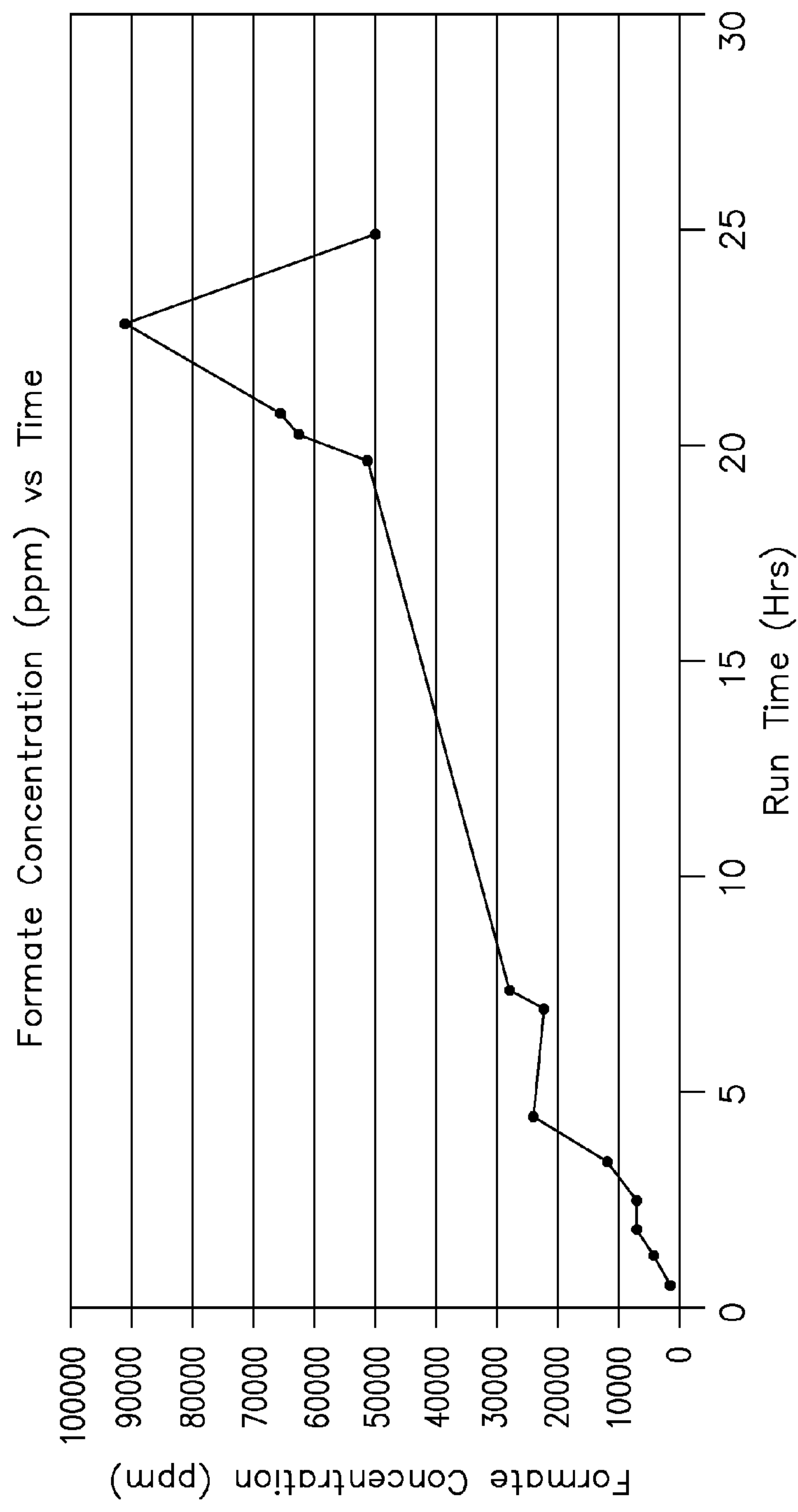

FIG. 14

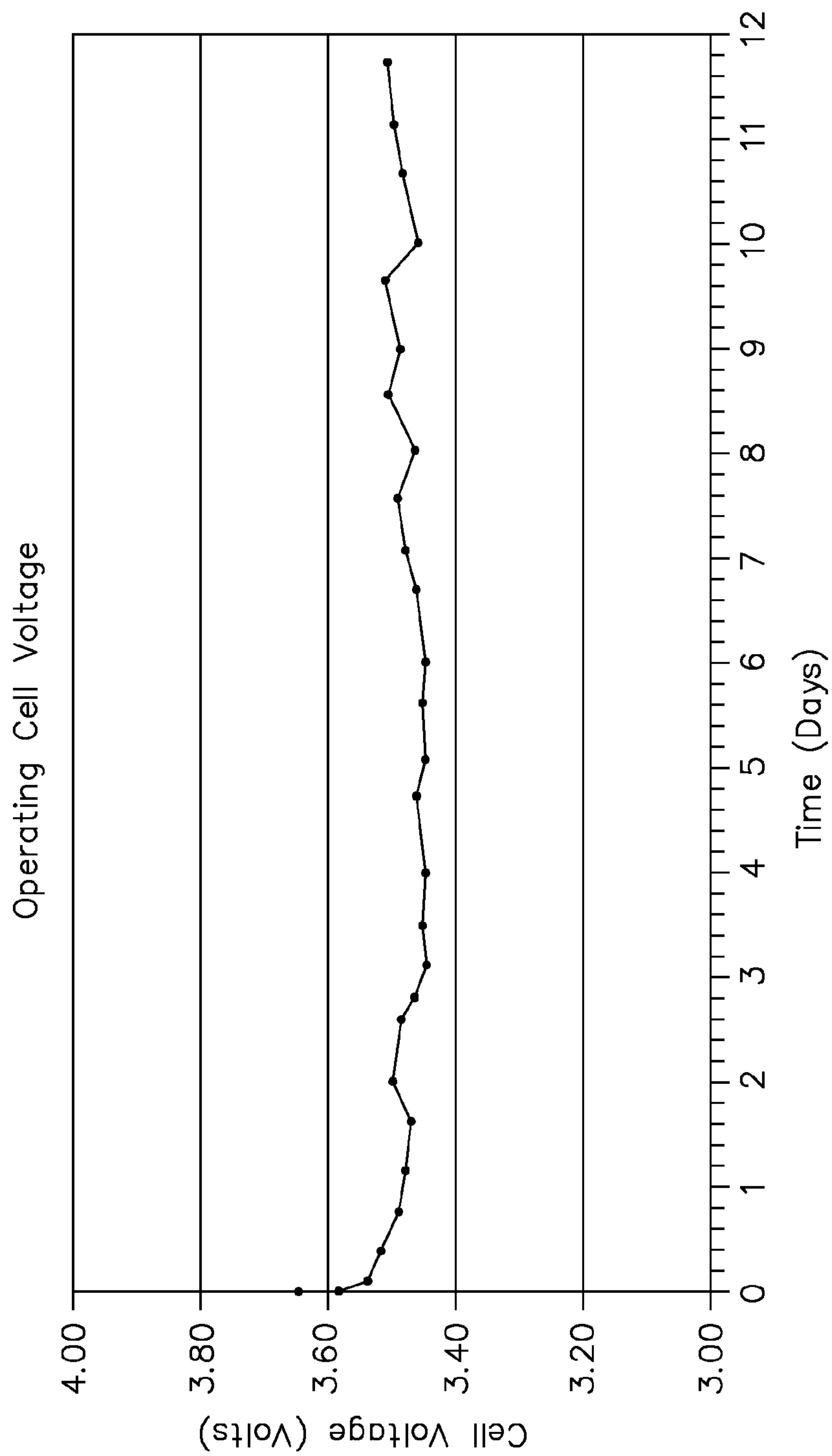

FIG. 15

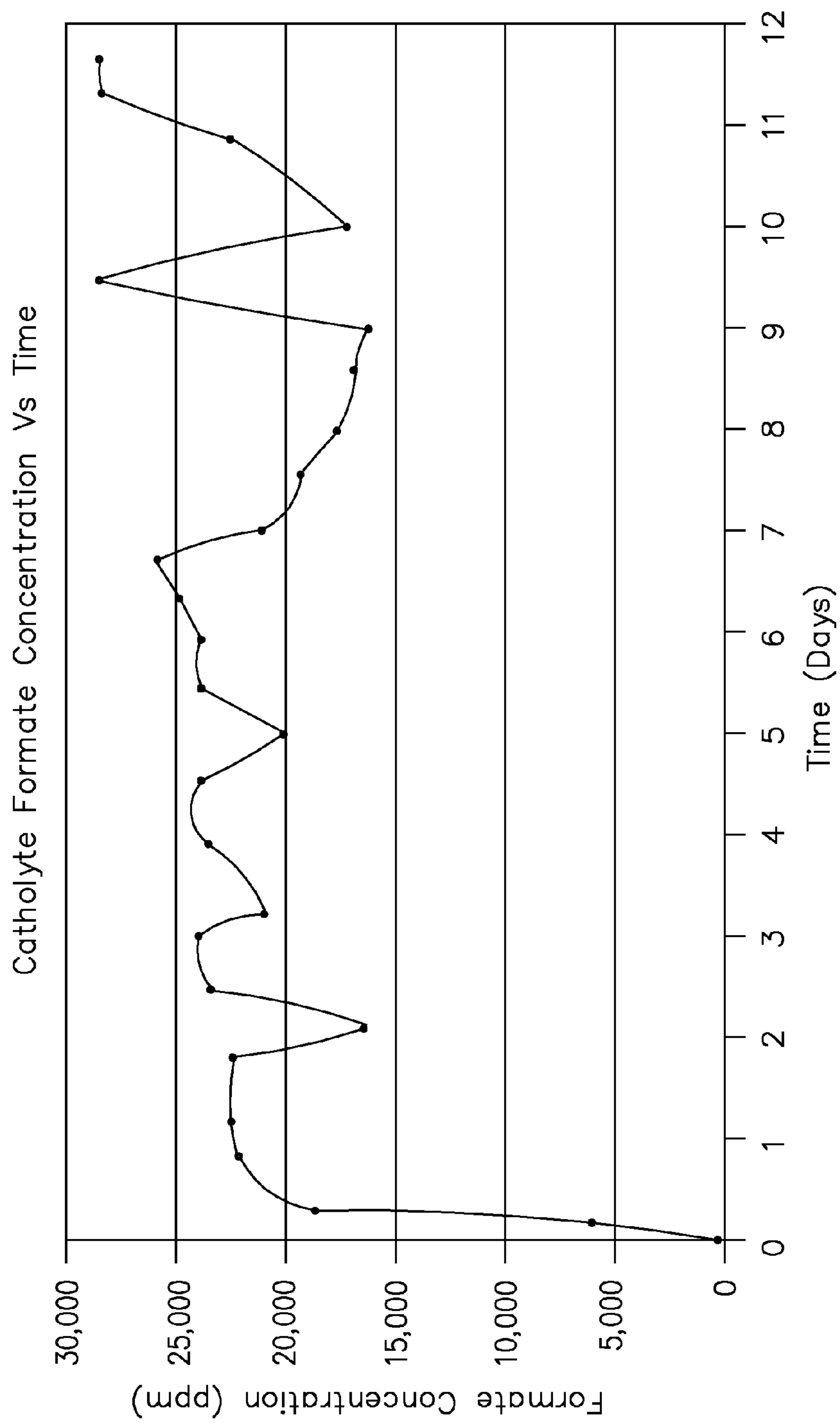

FIG. 16

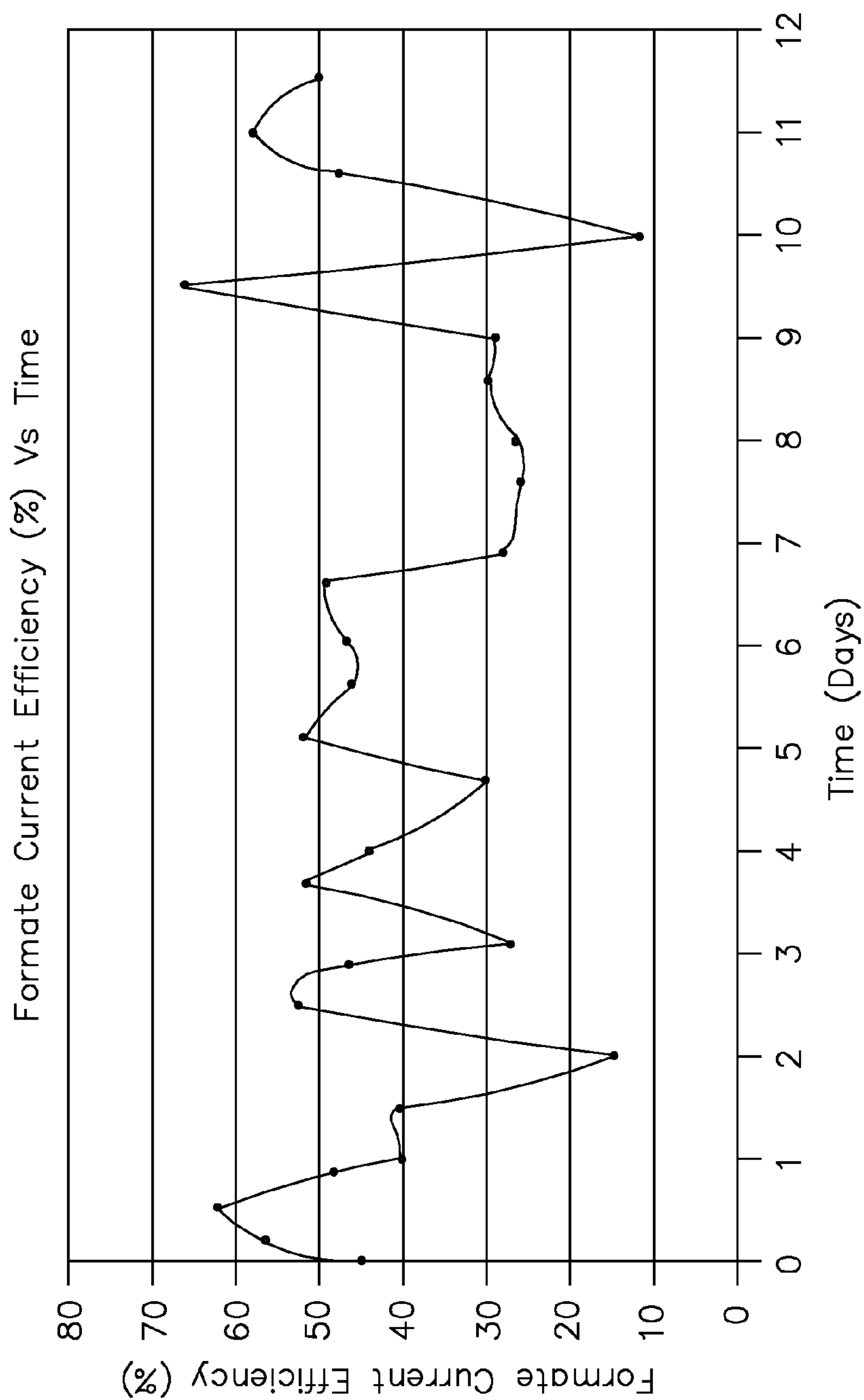

FIG. 19

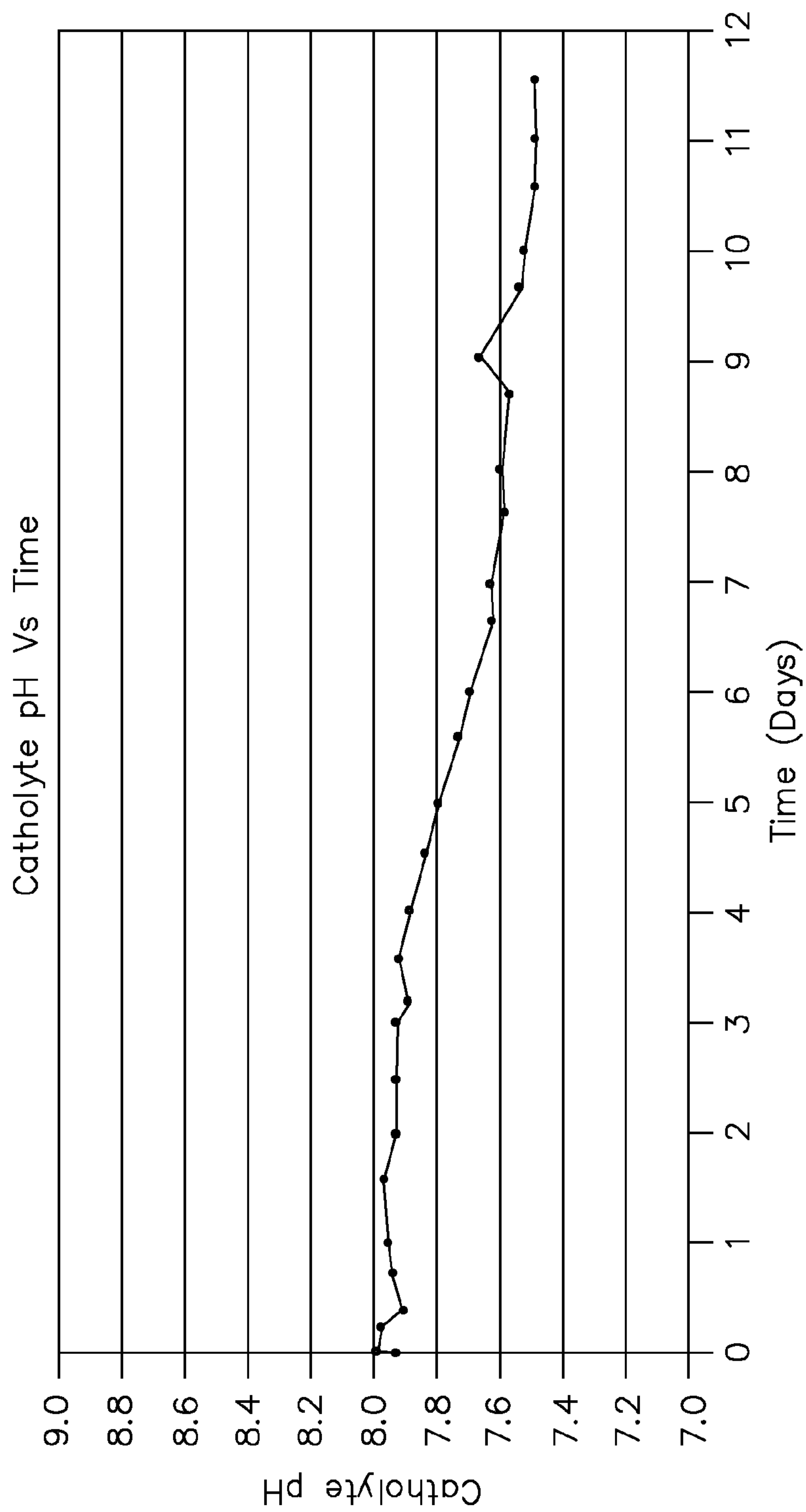

FIG. 20

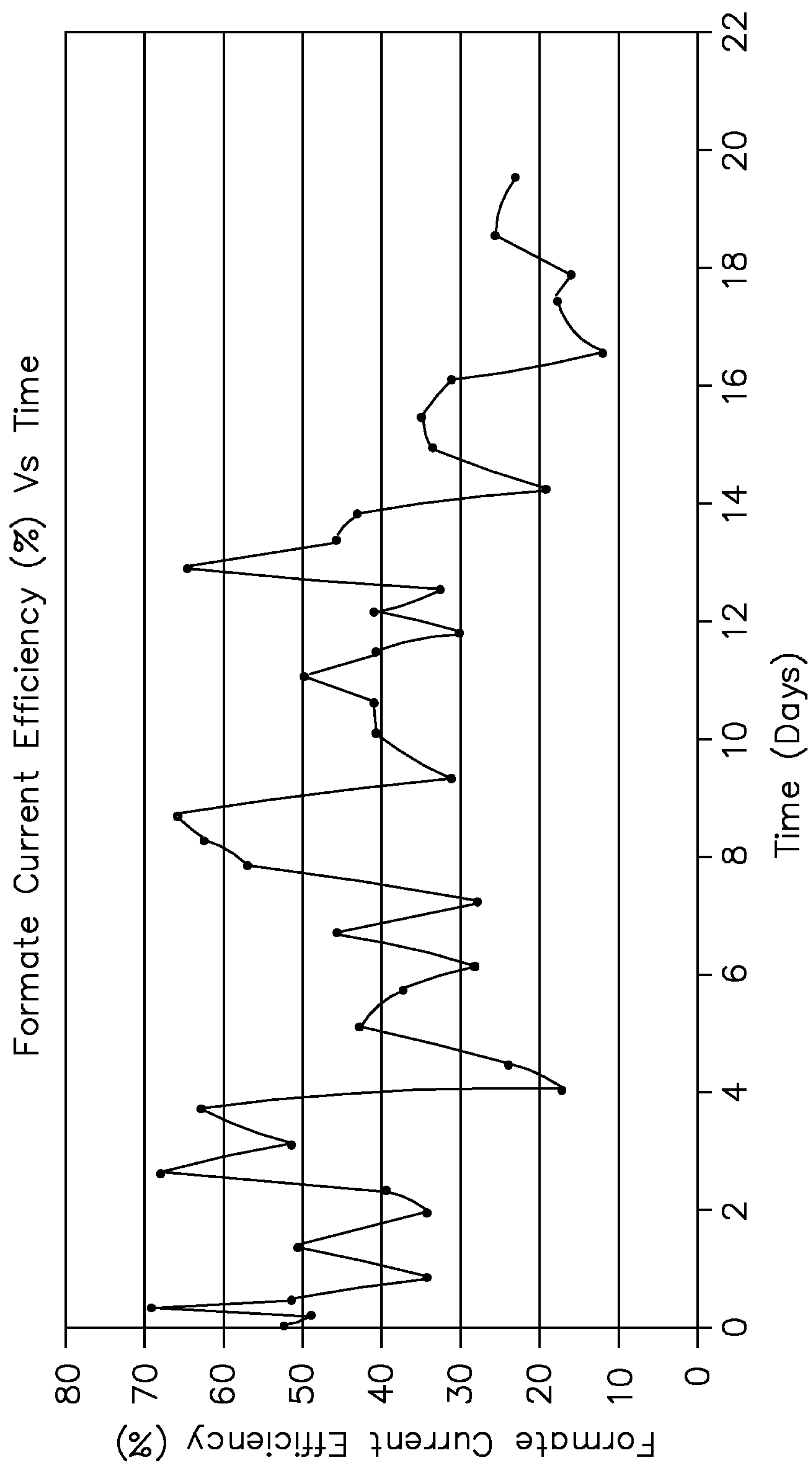

FIG. 21



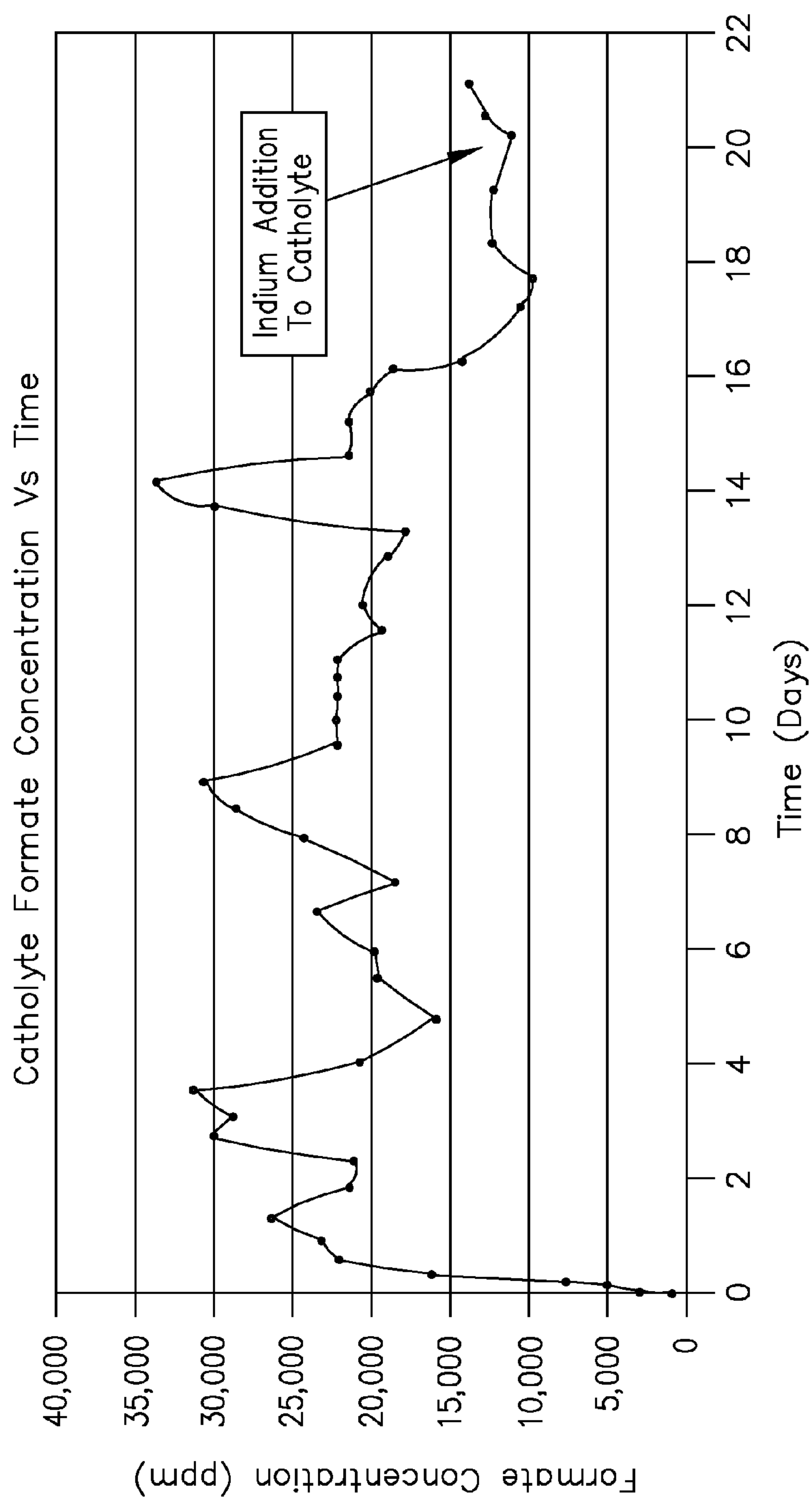

FIG. 22

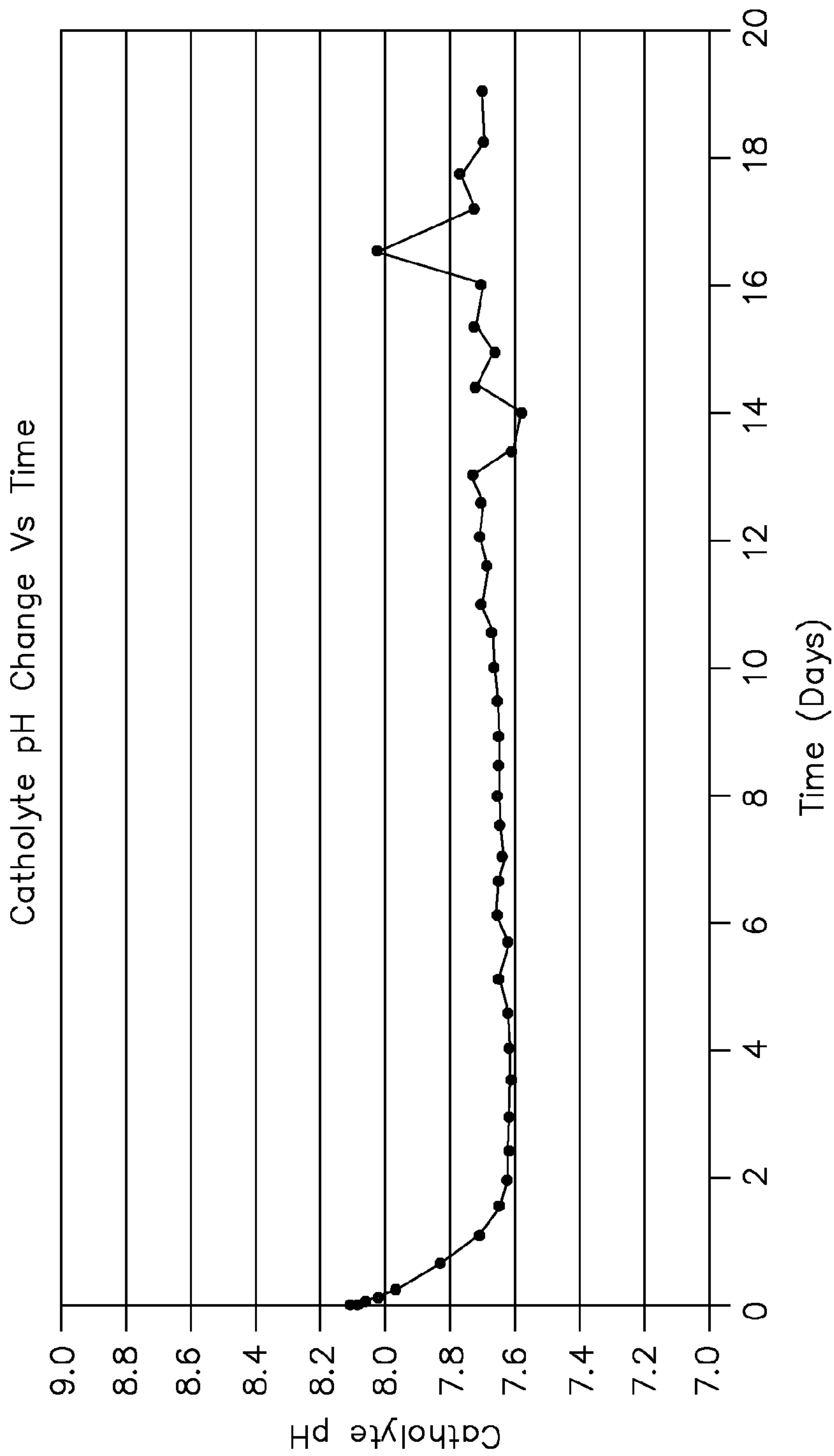

FIG. 23

**SYSTEM AND HIGH SURFACE AREA  
ELECTRODES FOR THE  
ELECTROCHEMICAL REDUCTION OF  
CARBON DIOXIDE**

CROSS-REFERENCE TO RELATED  
APPLICATIONS

**[0001]** The present application claims the benefit under 35 U.S.C. §119(e) of U.S. Patent Application Ser. No. 61/701,237, filed Sep. 14, 2012, which is hereby incorporated by reference in its entirety.

**[0002]** The present application also claims the benefit under 35 U.S.C. §119(e) of U.S. Provisional Application Ser. No. 61/703,158 filed Sep. 19, 2012, U.S. Provisional Application Ser. No. 61/703,175 filed Sep. 19, 2012, U.S. Provisional Application Ser. No. 61/703,231 filed Sep. 19, 2012, U.S. Provisional Application Ser. No. 61/703,232, filed Sep. 19, 2012, U.S. Provisional Application Ser. No. 61/703,234, filed Sep. 19, 2012, U.S. Provisional Application Ser. No. 61/703,238 filed Sep. 19, 2012, U.S. Provisional Application Ser. No. 61/703,187 filed Sep. 19, 2012, U.S. Provisional Application Ser. No. 61/720,670 filed Oct. 31, 2012, U.S. Provisional Application Ser. No. 61/703,229 filed Sep. 19, 2012 and U.S. Provisional Application Ser. No. 61/675,938 filed Jul. 26, 2012. The U.S. Provisional Application Ser. No. 61/703,158 filed Sep. 19, 2012, U.S. Provisional Application Ser. No. 61/703,175 filed Sep. 19, 2012, U.S. Provisional Application Ser. No. 61/703,231 filed Sep. 19, 2012, U.S. Provisional Application Ser. No. 61/703,232, filed Sep. 19, 2012, U.S. Provisional Application Ser. No. 61/703,234, filed Sep. 19, 2012, U.S. Provisional Application Ser. No. 61/703,238 filed Sep. 19, 2012, U.S. Provisional Application Ser. No. 61/703,187 filed Sep. 19, 2012, U.S. Provisional Application Ser. No. 61/720,670 filed Oct. 31, 2012, U.S. Provisional Application Ser. No. 61/703,229 filed Sep. 19, 2012 and U.S. Provisional Application Ser. No. 61/675,938 filed Jul. 26, 2012 are hereby incorporated by reference in their entireties.

**[0003]** The present application incorporates by reference co-pending U.S. Patent application Attorney Docket 0017A, U.S. Patent application Attorney Docket 0022, U.S. Patent application Attorney Docket 0023, U.S. Patent application Attorney Docket 0024, U.S. Patent application Attorney Docket 0025, U.S. Patent application Attorney Docket 0026, U.S. Patent application Attorney Docket 0027, U.S. Patent application Attorney Docket 0028, U.S. Patent application Attorney Docket 0029, and U.S. Patent application Attorney Docket 0030 in their entireties.

FIELD

**[0004]** The present disclosure generally relates to the field of electrochemical reactions, and more particularly to methods and/or systems for electrochemical reduction of carbon dioxide using high surface area electrodes.

BACKGROUND

**[0005]** The combustion of fossil fuels in activities such as electricity generation, transportation, and manufacturing produces billions of tons of carbon dioxide annually. Research since the 1970s indicates increasing concentrations of carbon dioxide in the atmosphere may be responsible for altering the Earth's climate, changing the pH of the ocean and other

potentially damaging effects. Countries around the world, including the United States, are seeking ways to mitigate emissions of carbon dioxide.

**[0006]** A mechanism for mitigating emissions is to convert carbon dioxide into economically valuable materials such as fuels and industrial chemicals. If the carbon dioxide is converted using energy from renewable sources, both mitigation of carbon dioxide emissions and conversion of renewable energy into a chemical form that can be stored for later use may be possible.

SUMMARY OF THE PREFERRED  
EMBODIMENTS

**[0007]** The present invention is directed to using high surface area electrodes and particular electrolyte solutions to produce single carbon (C1) chemicals, including formic acid, and multi-carbon (C2+) based chemicals (i.e., chemicals with two or more carbon atoms in the compound). The present invention includes the process, system, and various components thereof.

**[0008]** It is to be understood that both the foregoing general description and the following detailed description are exemplary and explanatory only and are not necessarily restrictive of the disclosure as claimed. The accompanying drawings, which are incorporated in and constitute a part of the specification, illustrate an embodiment of the disclosure and together with the general description, serve to explain the principles of the disclosure.

BRIEF DESCRIPTION OF THE DRAWINGS

**[0009]** The numerous advantages of the present disclosure may be better understood by those skilled in the art by reference to the accompanying figures in which:

**[0010]** FIG. 1 is a flow diagram of a preferred electrolyzer system for the reduction of carbon dioxide in accordance with an embodiment of the present disclosure;

**[0011]** FIG. 2 is a flow diagram of a preferred electrochemical acidification system;

**[0012]** FIG. 3 is a flow diagram of another preferred system for the electrochemical reduction of carbon dioxide;

**[0013]** FIG. 4 is a flow diagram of another preferred electrochemical acidification system incorporating bipolar membranes;

**[0014]** FIG. 5 is flow diagram of another preferred electrochemical electrolyzer system incorporating an ion exchange compartment for the reduction of carbon dioxide; and

**[0015]** FIG. 6 is a flow diagram of a nano-filtration system in accordance with an embodiment of the present disclosure;

**[0016]** FIG. 7 is a chart illustrating cumulative yield of formate over time in accordance with an embodiment described with reference to Example 1 of the present disclosure;

**[0017]** FIG. 8 is a chart illustrating cumulative yield of formate over time in accordance with an embodiment described with reference to Example 2 of the present disclosure;

**[0018]** FIG. 9 is a chart illustrating cumulative yield of formate over time in accordance with an embodiment described with reference to Example 3 of the present disclosure;

**[0019]** FIG. 10 is a chart illustrating cumulative yield of formate over time in accordance with an embodiment described with reference to Example 4 of the present disclosure;



[0020] FIG. 11 is a chart illustrating cumulative formate yield versus time in accordance with an embodiment described with reference to Example 9 of the present disclosure;

[0021] FIG. 12 is a chart illustrating formate concentration versus time in accordance with an embodiment described with reference to Example 9 of the present disclosure;

[0022] FIG. 13 is a chart illustrating cumulative formate yield versus time in accordance with an embodiment described with reference to Example 10 of the present disclosure;

[0023] FIG. 14 is a chart illustrating formate concentration versus time in accordance with an embodiment described with reference to Example 10 of the present disclosure;

[0024] FIG. 15 is a chart illustrating operating cell voltage versus time in accordance with an embodiment described with reference to Example 11 of the present disclosure;

[0025] FIG. 16 is a chart illustrating catholyte formate concentration versus time in accordance with an embodiment described with reference to Example 11 of the present disclosure;

[0026] FIG. 17 shows a scanning electron microscope (SEM) image of the electroless indium coating on tin-plated copper fiber cathode used in Example 11 of the present disclosure;

[0027] FIG. 18 shows an SEM image of an electroless indium coating on a treated carbon fiber material;

[0028] FIG. 19 is a chart illustrating formate current efficiency versus time in accordance with an embodiment described with reference to Example 11 of the present disclosure;

[0029] FIG. 20 is a chart illustrating catholyte pH versus time in accordance with an embodiment described with reference to Example 11 of the present disclosure;

[0030] FIG. 21 is a chart illustrating formate current efficiency versus time in accordance with an embodiment described with reference to Example 12 of the present disclosure;

[0031] FIG. 22 is a chart illustrating catholyte formate concentration versus time in accordance with an embodiment described with reference to Example 12 of the present disclosure; and

[0032] FIG. 23 is a chart illustrating catholyte pH versus time in accordance with an embodiment described with reference to Example 12 of the present disclosure.

#### DETAILED DESCRIPTION OF THE PREFERRED EMBODIMENTS

[0033] Reference will now be made in detail to the presently preferred embodiments of the present disclosure, examples of which are illustrated in the accompanying drawings.

[0034] In accordance with some embodiments of the present disclosure, an electrochemical system is provided that converts carbon dioxide to organic products including formate and formic acid. Use of a cathode comprising a high surface area three dimensional material, an acidic anolyte, and a catholyte comprising bicarbonate facilitates the process.

[0035] Before any embodiments of the invention are explained in detail, it is to be understood that the embodiments described below do not limit the scope of the claims that follow. Also, it is to be understood that the phraseology and terminology used herein is for the purpose of description

and should not be regarded as limiting. The use of terms such as “including,” “comprising,” or “having” and variations thereof herein are generally meant to encompass the item listed thereafter and equivalents thereof as well as additional items. Further, unless otherwise noted, technical terms may be used according to conventional usage.

[0036] Referring to FIG. 1, a flow diagram of an electrolyzer system 100 is shown in accordance with an embodiment of the present invention. The electrolyzer system 100 may be utilized for the electrochemical reduction of carbon dioxide to organic products or organic product intermediates. Preferably, the electrolyzer system 100 reduces carbon dioxide to an alkali metal formate, such as potassium formate. The electrolyzer system 100 generally includes an electrolyzer 102, an anolyte recycle loop 104, and a catholyte recycle loop 106. The electrolyzer system 100 may include as process feeds/inputs carbon dioxide, a catholyte comprising bicarbonate (preferably potassium bicarbonate, but other bicarbonate-based compounds are contemplated instead of or in addition to potassium bicarbonate), and an acidic anolyte (preferably sulfuric acid, but may include other acids, instead of, or in addition to sulfuric acid). The product of the electrolyzer system 100 is generally an alkali metal formate, such as potassium formate, and may include excess catholyte, carbon dioxide, hydrogen, oxygen, and/or other unreacted process inputs.

[0037] The electrolyzer 102 generally includes an anode compartment 108 and a cathode compartment 110, and may further include a cation exchange membrane 112 to separate the anode compartment 108 from the cathode compartment 110. The anode compartment 108 includes an anode 114 suitable to oxidize water. In a preferred implementation, the anode 114 is a titanium anode having an anode electrocatalyst coating which faces the cation exchange membrane 112. For instance, the anode 114 may include an anode mesh screen 116 that includes a folded expanded titanium screen with an anode electrocatalyst coating. The anode mesh screen 116 may provide spacing and contact pressure between the anode 114 and the cation exchange membrane 112. The anode 114 may also include one or more electrical current connection posts (not shown) on a backside of the anode 114.

[0038] The cathode compartment 110 generally includes a cathode 118 mounted within the cathode compartment 110. The cathode 118 preferably includes a metal electrode with an active electrocatalyst layer on a front surface of the cathode 118 facing the cation exchange membrane 112, and may include one or more electrical current conduction posts (not shown) on a backside of the cathode 118. The cathode 118 preferably includes a high surface area cathode structure 120. The high surface area cathode structure 120 may be mounted between the cation exchange membrane 112 and the cathode 118 for conducting electrical current into the high surface area cathode structure 120. The interface between the high surface area cathode structure 120 and the cation exchange membrane 112 may include an insulator screen (not shown), such as a thin expanded plastic mesh insulator screen to minimize direct contact between the high surface area cathode structure 120 and the cation exchange membrane 112.

[0039] The anode compartment 108 generally includes an anode feed stream 122 that includes a dilute acid anolyte solution. The anode feed stream 122 may enter a bottom of the anode compartment 108 to flow by a face of the anode 114 and through the anode mesh screen 116. The reaction in the anode compartment 108 may include deriving oxygen (O<sub>2</sub>, i.e.,



gaseous oxygen) and hydrogen ions ( $H^+$ ) or protons from the oxidation of water at an applied current and voltage potential. The hydrogen ions or protons are generally available for the reactions within the cathode compartment 110 via the cation exchange membrane 112. The gaseous oxygen and other liquids leaving the anode compartment 108 of the electrolyzer 102 leave as anode exit stream 124. The anode exit stream 124 may be monitored by a temperature sensor 126a and may flow to an anolyte disengager 128 suitable for separating the oxygen from the anode exit stream 124. The anolyte disengager 128 may process the anode exit stream 124 into an oxygen stream 130, an anolyte recycle stream 132, and an anolyte overflow stream 134. The oxygen stream 130 may be vented from the anolyte disengager 128. The anolyte stream 132 may be combined with water (preferably deionized water) from a water source 136 and with acid (preferably sulfuric acid) from an acid source 138. The water source 136 and the acid source 138 in the anolyte recycle loop 104 may maintain anolyte acid strength and volume for the anode feed stream 122. The temperature of the anode feed stream 122 may be regulated by a heat exchanger 140a coupled with a cooling water source 142a prior to entering the anode compartment 108 of the electrolyzer 102.

[0040] The cathode compartment 110 generally includes a cathode feed stream 144 that includes carbon dioxide and a catholyte. In a preferred implementation, the catholyte is a bicarbonate compound, such as potassium bicarbonate ( $KHCO_3$ ), which is saturated with carbon dioxide. The cathode feed stream 144 may enter a bottom of the cathode compartment 110 to flow by a face of the cathode 118 and through the high surface area cathode structure 120. The reaction in the cathode compartment 110 may reduce carbon dioxide to formate at an applied current and voltage potential. The reaction products and any unreacted materials (e.g., excess catholyte solution) may exit the cathode compartment 110 as cathode exit stream 146. The cathode exit stream 146 may be monitored by a pH sensor 148a and a temperature sensor 126b and may flow to a catholyte disengager 150 suitable for separating gaseous components (e.g., hydrogen) from the cathode exit stream 146. The catholyte disengager 150 may process the cathode exit stream 146 into a hydrogen stream 152, a product stream 154, and a catholyte recycle stream 156. The hydrogen stream 152 may be vented from the catholyte disengager 150. The product stream 154 preferably includes an alkali metal formate (such as potassium formate where the electrolyte includes potassium bicarbonate) and may include excess catholyte. The catholyte stream 156 may be processed by a catholyte recirculation pump 158 and a heat exchanger 140b coupled with a cooling water source 142b. A temperature sensor 126c may monitor the catholyte stream 156 downstream from the heat exchanger 140b having cooling water source 142b. A fresh catholyte electrolyte feed 160 may be metered into the catholyte stream 156, where the fresh catholyte electrolyte feed 160 may adjust the pH of the cathode feed stream 144 into the cathode compartment 110 of the electrolyzer 102, which may control final product overflow rate and establish the formate product concentration. The pH may be monitored by pH sensor 148b. A carbon dioxide stream 162 may be metered into the cathode feed stream 144 downstream from the catholyte electrolyte feed 160 prior to entering the cathode compartment 110 of the electrolyzer 102. Preferably, the carbon dioxide saturates the catholyte entering the cathode compartment.

[0041] When using an acidic anolyte, where protons are passed through the membrane into the cathode compartment, the pH of the electrolyzer 102 may be controlled or maintained through use of an alkali metal bicarbonate and/or carbonate in combination with water to control the pH of the catholyte. By controlling the pH of the catholyte at an optimum value, the cell may more efficiently convert carbon dioxide into C1 and C2 products with a higher conversion rate than if a non-optimum pH value was maintained or if no pH control mechanism was employed. In a preferred process, the catholyte is constantly recirculated to maintain an adequate and uniform carbon dioxide concentration at cathode surfaces coated with an electrocatalyst. A fresh catholyte feed stream may be used to control the pH of the catholyte and to control the product concentration in the product overflow stream. The mass flow rate of the catholyte feed to the cathode compartment (e.g., mass flow of potassium bicarbonate) is preferably balanced with the introduction of protons into the catholyte and with the formation of hydroxide from the inefficient byproduct reaction of water splitting at the cathode. The concentration of the potassium bicarbonate is important, since it provides volume to the catholyte, which will dilute the product in the catholyte.

[0042] For pH control of the catholyte, potassium bicarbonate is preferred, in a concentration range of 5 to 600 gm/L, or more preferably in the 10 to 500 gm/L range. If the feed concentration of bicarbonate to the catholyte is fixed, a separate feed of water may be employed into the catholyte to control final product concentration. In another implementation, potassium carbonate may be used as a feed for pH control. Potassium carbonate has a much higher solubility in water than potassium bicarbonate, and is preferably used in a concentration range of 5 to 1,500 gm/L.

[0043] Referring now to FIG. 2, a block diagram of an electrochemical acidification system 200 is shown in accordance with an embodiment of the present invention. The electrochemical acidification system 200 may be utilized to acidify the product stream 154 from the electrolyzer system 100. Preferably, the electrochemical acidification system 200 acidifies an alkali metal formate, such as potassium formate, to form an organic acid, such as formic acid, and co-produce an alkali metal hydroxide, such as potassium hydroxide. The electrochemical acidification system 200 generally includes an electrochemical acidification unit 202, an anolyte recycle loop 204, and a catholyte recycle loop 206. The electrochemical acidification system 200 may include as process feeds/inputs the product stream 154 from the electrolyzer system 100 (which preferably includes an alkali metal formate), water in each of the anolyte recycle loop 204 and the catholyte recycle loop 206, and an acidic anolyte (preferably sulfuric acid, but may include other acids, instead of, or in addition to sulfuric acid). The product of the electrochemical acidification system 200 is generally an organic acid, such as formic acid, and an alkali metal hydroxide, and may include residual alkali metal formate, bicarbonate catholyte, carbon dioxide, hydrogen, oxygen, and/or other unreacted process inputs.

[0044] The electrochemical acidification unit 202 is preferably a three-compartment electrochemical acidification unit or cell. The electrochemical acidification unit 202 generally includes an anode compartment 208, a cathode compartment 210, and a central ion exchange compartment 212 bounded by cation exchange membranes 214a and 214b on each side. The anode compartment 208 includes an anode 216 suitable to oxidize water. In a preferred implementation, the



anode **216** is a titanium anode having an anode electrocatalyst coating which faces the cation exchange membrane **214a**. The cathode compartment **210** includes a cathode **218** suitable to reduce water and to generate an alkali metal hydroxide. In a preferred implementation, hydrogen ions (H<sup>+</sup>) or protons are generated in the anode compartment **208** when a potential and current are applied to the electrochemical acidification unit **202**. The hydrogen ions (H<sup>+</sup>) or protons pass through the cation exchange membrane **214a** into the central ion exchange compartment **212**. The product stream **154** from the electrolyzer system **100** is preferably introduced to the electrochemical acidification unit **202** via the central ion exchange compartment **212**, where the hydrogen ions (H<sup>+</sup>) or protons displace the alkali metal ions (e.g., potassium ions) in the product stream **154** to acidify the stream and produce a product stream **260** including an organic acid product, preferably formic acid. The displaced alkali metal ions may pass through the cation exchange membrane **214b** to the cathode compartment **210** to combine with hydroxide ions (OH<sup>-</sup>) formed from water reduction at the cathode **218** to form an alkali metal hydroxide, preferably potassium hydroxide.

[0045] The central ion exchange compartment **212** may include a plastic mesh spacer (not shown) to maintain the dimensional space in the central ion exchange compartment **212** between the cation exchange membranes **214a** and **214b**. In an embodiment, a cation ion exchange material **220** is included in the central ion exchange compartment **212** between the cation exchange membranes **214a** and **214b**. The cation ion exchange material **220** may include an ion exchange resin in the form of beads, fibers, and the like. It is contemplated that the cation ion exchange material **220** may increase electrolyte conductivity in the ion exchange compartment solution, and may reduce the potential effects of carbon dioxide gas on the cell voltage as bubbles are formed and pass through the central ion exchange compartment **212**.

[0046] The anode compartment **208** generally includes an anode feed stream **222** that includes an acid anolyte solution (preferably a sulfuric acid solution). The gaseous oxygen and other liquids leaving the anode compartment **208** of the electrochemical acidification unit **202** leave as anode exit stream **224**. The anode exit stream **224** may be monitored by a temperature sensor **226a** and may flow to an anolyte disengager **228** suitable for separating the oxygen from the anode exit stream **224**. The anolyte disengager **228** may process the anode exit stream **224** into an oxygen stream **230**, an anolyte recycle stream **232**, and an anolyte overflow stream **234**. The oxygen stream **230** may be vented from the anolyte disengager **228**. The anolyte stream **232** may be combined with water (preferably deionized water) from a water source **236** and with acid (preferably sulfuric acid) from an acid source **238**. The water source **236** and the acid source **238** in the anolyte recycle loop **204** may maintain anolyte acid strength and volume for the anode feed stream **222**. The temperature of the anode feed stream **222** may be regulated by a heat exchanger **240a** coupled with a cooling water source **242a** prior to entering the anode compartment **208** of the electrochemical acidification unit **202**.

[0047] The cathode compartment **210** generally includes a catholyte feed stream **244** that includes water and may include an alkali metal hydroxide that circulates through the catholyte recycle loop **206**. The reaction products, which may include the alkali metal hydroxide and hydrogen gas, may exit the cathode compartment **210** as cathode exit stream **246**. The cathode exit stream **246** may be monitored by a tempera-

ture sensor **226b** and may flow to a catholyte disengager **248** suitable for separating gaseous components (e.g., hydrogen) from the cathode exit stream **246**. The catholyte disengager **248** may process the cathode exit stream **246** into a hydrogen stream **250**, a catholyte stream **252**, and a catholyte overflow stream **254**, which may include KOH. The hydrogen stream **250** may be vented from the catholyte disengager **248**. The catholyte stream **252** preferably includes an alkali metal hydroxide (such as potassium hydroxide where the product stream **154** includes potassium formate). The catholyte stream **252** may be processed by a catholyte recirculation pump **256** and a heat exchanger **240b** coupled with a cooling water source **242b**. A temperature sensor **226c** may monitor the catholyte stream **252** downstream from the heat exchanger **240b**. The catholyte stream **252** may be combined with water (preferably deionized water) from a water source **258**, where the water may be metered to control the concentration of the alkali metal hydroxide in the catholyte feed stream **244** entering the cathode compartment **210**.

[0048] Referring now to FIG. 3, a flow diagram of a preferred system **300** for the electrochemical reduction of carbon dioxide to an organic acid product is shown. The system **300** may incorporate the electrolyzer system **100** (described with reference to FIG. 1) and the electrochemical acidification system **200** (described with reference to FIG. 2), and preferably includes a potassium hydroxide recycle loop **302** suitable for the production of potassium bicarbonate from potassium hydroxide and carbon dioxide. The system **300** may also incorporate carbon dioxide processing components for the separation (e.g., gas separation units **304a**, **304b**, **304c**, **304d**) and recovery of carbon dioxide from process streams.

[0049] The system **300** generally includes carbon dioxide, an alkali metal hydroxide (preferably potassium hydroxide), an acid (preferably sulfuric acid), and water (preferably deionized water) as process inputs and generally includes an organic acid (preferably formic acid), oxygen gas, and hydrogen gas as process outputs. The organic acid may undergo additional processing to provide a desired form and concentration. Such processing may include evaporation, distillation, or another suitable physical separation/concentration process.

[0050] The chemistry of the reduction of carbon dioxide in the system **300** may be as follows.

[0051] Hydrogen atoms are adsorbed at the electrode from the reduction of water as shown in equation (1).



[0052] Carbon dioxide is reduced at the cathode surface with the adsorbed hydrogen atom to form formate, which is adsorbed on the surface as in equation (2).



[0053] The adsorbed formate on the surface then reacts with another adsorbed hydrogen atom to form formic acid that is then released into the solution as in equation (3)



[0054] The competing reaction at the cathode is the reduction of water where hydrogen gas is formed as well as hydroxide ions as in equation (4).



[0055] The anode reaction is the oxidation of water into oxygen and hydrogen ions as shown in equation (5).





**[0056]** High Surface Area Cathode

**[0057]** As described with reference to FIG. 1, the cathode **118** preferably includes a high surface area cathode structure **120**. The high surface area cathode structure **120** preferably includes a void volume ranging from 30% to 98%. The specific surface area of the high surface area cathode structure **120** is preferably from  $2 \text{ cm}^2/\text{cm}^3$  to  $500 \text{ cm}^2/\text{cm}^3$  or higher. The surface area also can be defined as total area in comparison to the current distributor/conductor back plate, with a preferred range of 2× to 1000× or more.

**[0058]** The cathode **118** preferably includes electroless indium on tin (Sn) coated copper woven mesh, copper screen, copper fiber as well as bronze and other are copper-tin alloys, nickel and stainless steels. The metals may be precoated with other metals, such as to adequately form a suitable base for the application of the indium and other preferred cathode coatings. The cathode may also include Indium-Cu intermetallics formed on the surfaces of copper fiber, woven mesh, copper foam or copper screen. The intermetallics are generally harder than the soft indium metal, and may provide desirable mechanical properties in addition to usable catalytic properties. The cathode may also include, but is not limited to coatings and/or metal structures containing Pb, Sn, Hg, Tl, In, Bi, and Cd, their alloys, and combinations thereof. Metals including Ti, Nb, Cr, Mo, Ag, Cd, Hg, Tl, An, and Pb as well as Cr—Ni—Mo steel alloys among many others may be incorporated. The cathode **118** may include a single or multi-layered electrode coating, such that the electrocatalyst coating on the cathode substrate includes one or more layers of metals and alloys. A preferred electrocatalyst coating on the cathode includes a tin coating on a high surface area copper substrate with a top layer/coating of indium. The indium coating coverage preferably ranges from 5% to 100% as indium.

**[0059]** In the use of indium alloys on the exposed catalytic surfaces of the electrode, the indium composition preferably ranges from 5% to 99% as indium in alloys with other metals, including Sn, Pb, Hg, Tl, Bi, Cu, and Cd and their mixed alloys and combinations thereof. It is also contemplated to include Au, Ag, Zn, and Pd into the coating in percentages ranging from 1% to 95%.

**[0060]** Additionally, metal oxides may be used or prepared as electrocatalysts on the surfaces of the base cathode structure. For example, lead oxide can be prepared as an electrocatalyst on the surfaces of the base cathode structure. The metal oxide coating could be formed by a thermal oxidation method or by electro-deposition followed by chemical or thermal oxidation.

**[0061]** Additionally, the cathode base structure can also be graduated or graduated, such that the density of the cathode can be varied in the vertical or horizontal directions in terms of density, void volume, or specific surface area (e.g., varying fiber sizes). The cathode structure may also consist of two or more different electrocatalyst compositions that are either mixed or located in separate regions of the cathode structure in the catholyte compartment.

**[0062]** During normal operation of the electrolyzer **102**, the performance of the system may decrease with regard to formate yield which may result from catalyst loss or over-coating of the catalyst with impurities, such as other metals that may be plated onto the cathode **118**. The surfaces of the cathode **118** may be renewed by the periodic addition of indium salts or a mix of indium/tin salts in situ during operation of the electrolyzer **102**. Depending on the composition of

the cathode **118**, it is contemplated that other or additional metal salts may be added in situ including salts of Ag, Au, Mo, Cd, Sn, and other suitable metals, singly or in combination. The electrolyzer **102** may be operated at full rate during operation, or temporarily operated at a lower current density with or without any carbon dioxide addition during the injection of the metal salts. The conditions under which to renew the cathode surface with the addition of these salts may differ depending on desired renewal results. The use of an occasional brief current reversal during electrochemical cell operation may also be employed to potentially renew the cathode surfaces.

**[0063]** In particular embodiments, the electrolyzer **102** is operated at pressures exceeding atmospheric pressure, which may result in higher current efficiency and permit operation of the electrolyzer **102** at higher current densities than when operating the electrolyzer **102** at or below atmospheric pressure.

**[0064]** In preparing cathode materials for the production of organic chemicals, the addition of metal salts that can reduce on the surfaces of the cathode structure can be also used, such as the addition of Ag, Au, Mo, Cd, Sn, and other suitable metals. Such addition of metal salts may provide a catalytic surface that may be otherwise difficult to prepare directly during cathode fabrication or for renewal of the catalytic surfaces.

**[0065]** A preferred method for preparing the high surface area cathode structure **120** is using an electroless plating solution which may include an indium salt, at least one complexing agent, a reducing agent, a pH modifier, and a surfactant. The preferred procedure for forming an electroless indium coating on the high surface area cathode may include combining in stirred deionized water the following materials: Trisodium citrate dihydrate (100 g/L), EDTA-disodium salt (15 g/L), sodium acetate (10 g/L),  $\text{InCl}_3$  (anhydrous, 10 g/L), and Thiodiglycolic acid (0.3 g/L, e.g., 3 mL of 100 mg/mL solution). A pre-mixed stock deposition solution that has been stirred (preferably for multiple hours, e.g., overnight) may also be used. The procedure also includes heating the mixture to about 40° C. The procedure also includes adding 40 mL  $\text{TiCl}_3$  (20 wt. % in 2% HCl) per liter [0.05 mM] and adding 7M ammonia in methanol until the pH of the mixture is approximately 7 (~15 mL ammonia solution per liter) at which point ammonium hydroxide (28% ammonia solution) is used to adjust the pH to between approximately 9.0 and 9.2. The procedure then includes heating the mixture to about 60° C. If the pH drops, adjust the pH to approximately 9.0 with ammonium hydroxide solution. The procedure then includes heating the mixture to about 75° C., where deposition may begin at about 65° C. The procedure includes holding the mixture at 75° C. for about one hour.

**[0066]** A preferred procedure for the metallic coating of copper substrates may include rinsing bare copper substrates in acetone to clean the copper surface (e.g., removing residual oils or grease that may be present on the copper surface) and then rinsing the acetone-treated copper substrates in deionized water. The procedure also includes immersing the bare copper substrates in a 10% sulfuric acid bath for approximately 5 minutes, and then rinsing with deionized water. The procedure also includes depositing approximately 25  $\mu\text{m}$  of tin on the copper surface. The deposition may be done using a commercial electroless tinning bath (Caswell, Inc.) operated at 60° C. for 15 minutes. Following tin deposition, parts are rinsed thoroughly in deionized water. The procedure also



includes depositing approximately 1  $\mu\text{m}$  of indium on the tinned copper surface. The deposition may be done using an electroless bath operated at 90° C. for 60 minutes. Following indium deposition, parts are rinsed thoroughly in deionized water. The procedure may also include treating the copper/tin/indium electrode in a 5 wt % nitric acid bath for 5 minutes. Such treatment may improve electrode stability as compared to an untreated copper/tin/indium electrode. In another implementation, the electroless tin plated copper substrate may be dipped into molten indium for coating.

**[0067]** In particular implementations, cathode substrates may be treated with catalytic materials for carbon dioxide reduction. Four example treatments are presented by the following.

**[0068]** A first treatment may include coating a conductive substrate (e.g., vitreous carbon or metal) in a conductive sol-gel containing sufficient catalyst material to yield a high active surface area. The conductive component of the sol-gel may be catalytically active. After coating the substrate with the catalytic sol-gel, the sol-gel is allowed to undergo a high degree of polymerization/cross-linking. The combined substrate/sol-gel structure may then be pyrolyzed at high temperature to convert organic material to amorphous (and potentially conductive) carbon. The pyrolyzed structure may also be subjected to chemical treatments that selectively remove the organic material or the silica phase, leading to a high catalyst content coating.

**[0069]** The second treatment may include binding relatively small particles (e.g., micron or nanometer scale) to a substrate using a binding agent such as amines, thiols, or other suitable binding agent. The binding agent is preferably conductive to pass current between the substrate and catalyst particles. The catalyst particles preferably include conjugated organic molecules, such as diphenylbenzene. If the substrate is also made of catalyst material the binding agent may have symmetrical binding groups, otherwise binding agents with two different binding groups may be utilized.

**[0070]** The third treatment may include coating a substrate in a slurry containing catalyst material (which may be in salt form) and a binding agent. The slurry may also contain a conductive additive, such as carbon black, carbon nanotubes, or other suitable conductive additive. The slurry coating may then be dried to form a conformal coating over the substrate. The substrate and dried slurry coating may be heated in order to fuse the various constituent materials into a mechanically robust, conductive, and catalytic material. In a particular implementation, the heating of the substrate and dried slurry coating occurs in a reducing environment.

**[0071]** The fourth treatment may include coating a substrate with semiconducting metal chalcogenides by applying a precursor to the substrate, removing solvent, and baking the substrate to convert the precursor material to a monolithic semiconducting metal chalcogenide coating. The coating materials may include, but are not limited to,  $\text{Na}_4\text{SnS}_4$ ,  $\text{Na}_4\text{Sn}_2\text{S}_6$ ,  $\text{K}_4\text{SnTe}_4$ ,  $\text{Na}_3\text{AsS}_3$ ,  $(\text{NH}_4)_4\text{Sn}_2\text{S}_6$ ,  $(\text{NH}_4)_3\text{AsS}_3$ , and  $(\text{NH}_4)_2\text{MoS}_4$ .

**[0072]** Other coating and electrocatalyst preparation techniques include applying thermal oxides onto a substrate, forming an intermetallic with a substrate, and applying semiconductor materials on a substrate. In an embodiment, the thermal oxidation of various metal salts painted onto various metal and ceramic substrates is preferred for forming high surface area materials suitable for the electrochemical reduction of carbon dioxide. The thermal oxidation may be similar

to that used for forming electrocatalysts on titanium for use as anode materials in electrochemical chlorine cells, such as iridium oxide and ruthenium oxide. In another embodiment, indium is electroplated onto a copper foil, then the copper foil is heated to 40° C. above the melting point of indium, until indium is melted on the foil surface, and forming a golden intermetallic with copper, and then cooled. The formation of the intermetallic can be done in air or under an inert gas atmosphere (e.g., argon or helium) or under a full or partial vacuum. The electroplated material preferably provides approximately 50% Faradaic conversion efficiency, and may be utilized as a coating on planar metal back plates and also on copper fibers. An intermetallic may also be formed with tin-plated copper substrates. In a further embodiment, a semiconductor material may be applied to a substrate by gaseous deposition, sputtering, or other suitable application methods. The substrate is preferably a metallic substrate. The semiconductor materials may be doped to P-type or N-type as desired.

**[0073]** In the four treatments and other coating techniques described above, certain measures may be taken to improve the quality (mechanical, electrical, etc.) of the bond between the substrate and catalyst. Such measures may involve creating functional groups on the substrate surface that can undergo chemical bonding with the catalyst or a binding agent, or the creation of geometrical features in the substrate surface that facilitate bonding with an applied catalyst coating.

**[0074]** The substrate for the high surface area cathodes described herein may include RVC materials, such as carbon and graphite, metal foams, woven metals, metal wools made from fibers, sintered powder metal films and plates, metal and ceramic beads, pellets, ceramic and metal column and trickle bed packing materials, metal and inorganic powder forms, metal fibers and wools, or other suitable substrate materials. The specific surface area of the physical forms preferably include a specific surface area between approximately 2 and 2,000  $\text{cm}^2/\text{cm}^3$  or greater.

**[0075]** The electrode or high surface area structure of an electrode may incorporate alloys as fibers or wools, and may be coated with various compounds, and subsequently fired in air or in a reducing atmosphere oven, to form stable oxides on the surfaces which are electrocatalytic in the reduction of carbon dioxide. Other cathode materials may include metallic glasses and amorphous metals.

**[0076]** Referring now to FIG. 4, a particular implementation of the acid acidification system 200 of FIG. 2 is shown utilizing bipolar membranes in an electrochemical acidification unit 402. By utilizing bipolar membranes in electrochemical acidification unit 402, the alkali metal formate (e.g., potassium formate) may be acidified in addition to recovering potassium hydroxide. The use of the bipolar membranes may reduce the voltage required for the acidification of the alkali metal formate and may reduce the number of actual anodes and cathodes needed for the electrochemical stack. The bipolar membranes preferably consist of a cation membrane and an anion membrane that have been bonded together, and function by splitting water at the two membrane interface, forming hydrogen ( $\text{H}^+$ ) ions from the cation membrane and hydroxide ions ( $\text{OH}^-$ ) from the anion membrane.

**[0077]** Referring now to FIG. 5, an alternative embodiment of the electrochemical system 100 of FIG. 1 is shown. The electrolyzer 502 in FIG. 5 includes an ion exchange compartment 504 in addition to an anode 506 compartment and a cathode compartment 508. This ion exchange compartment



**504** functions similarly as the acid acidification compartment **212** in electrochemical acidification unit **202** as shown in FIG. 2. The alkali metal formate product (e.g., potassium formate) and unreacted  $\text{KHCO}_3$  from the cathode compartment is passed through the ion exchange compartment **504** to provide a formic acid product with  $\text{CO}_2$  and some residual  $\text{KHCO}_3$ . The hydrogen ions ( $\text{H}^+$ ) passing through the adjacent membrane **510a** on the anode compartment side displace the alkali metal ions (e.g.,  $\text{K}^+$ ) in the stream passing through the central ion exchange compartment **504** so that the alkali metal formate is acidified and the alkali metal ions and remaining hydrogen ions pass through the adjoining membrane **510b** on the cathode compartment **508** and into the catholyte. This will allow operation of the catholyte at higher pH conditions if required for obtaining high Faradaic current efficiencies with the cathodes selected for the process.

[0078] In an indium-based cathode system, the preferred catholytes include alkali metal bicarbonates, carbonates, sulfates, phosphates, and the like. Other preferred catholytes include borates, ammonium, and hydroxides. Other catholytes may include chlorides, bromides, and other organic and inorganic salts. Non-aqueous electrolytes, such as propylene carbonate, methanesulfonic acid, methanol, and other ionic conducting liquids may be used, which may be in an aqueous mixture, or as a non-aqueous mixture in the catholyte. The introduction of micro bubbles of carbon dioxide into the catholyte stream may improve carbon dioxide transfer to the cathode surfaces.

[0079] Referring now to FIG. 6, a nano-filtration system may be utilized between the electrolyzer system **100**, as shown in FIG. 1, and the electrochemical acidification system **200**, as shown in FIG. 2. The nano-filtration system is preferably utilized to separate alkali metal formate (e.g., potassium formate) from bicarbonate leaving the electrolyzer system **100** (e.g., stream **154**) to reduce the amount of bicarbonate entering the electrochemical acidification unit **202**. The nano-filtration system preferably uses a nano-filtration filter/membrane under pressure for selective separation of the bicarbonate from the alkali metal formate. The nano-filtration filter/membrane separates monovalent anions (e.g., formate) from divalent anions (e.g., carbonate) using a high pressure pump and suitable selected membranes for the separation. When utilizing the nano-filtration system as a separation tool between the electrolyzer system **100** and the electrochemical acidification system **200**, the bicarbonate in the formate/bicarbonate product (e.g., stream **154**) is preferably converted to carbonate in order to efficiently separate the formate from the carbonate with the nano-filtration filter/membrane. The nano-filtration system may include a mixer, such as a mixing tank, to mix the formate/bicarbonate product stream with a potassium hydroxide (KOH) stream. The mixer may promote the conversion of potassium bicarbonate to potassium carbonate to facilitate the separation of the formate from the carbonate. A high pressure pump then sends the potassium formate/carbonate stream into a nano-filtration unit which includes the nano-filtration filter/membrane. The nano-filtration unit produces a low-carbonate-containing potassium formate permeate stream which is then sent to the electrochemical acidification system **200** as shown in FIG. 2 as stream **154**, to enter the electrochemical acidification unit **202**. The potassium carbonate containing reject stream leaving the nano-filtration unit is preferably sent to the  $\text{KHCO}_3$  block of FIG. 3, where the potassium carbonate is mixed with KOH and  $\text{CO}_2$  for conversion to potassium bicarbonate. The

potassium bicarbonate is preferably utilized as a feed to the cathode compartment of the electrolyzer **102** of the electrolyzer system **100**. The nano-filtration separation system may consist of multiple units connected in a series flow configuration to increase the total separation efficiency of the carbonate from formate separation. The system may also utilize recycle streams to recycle an output stream from one unit to the input of another unit to maintain flow and pressures as well as to increase the recovery of the formate.

[0080] Depending on the chemistry of the electrochemical systems described herein, the pH of the catholyte preferably ranges from 3 to 12. The desired pH of the catholyte may be a function of the catholyte operating conditions and the catalysts used in the cathode compartment, such that there is limited or no corrosion at the electrochemical cell.

[0081] Preferable catholyte cross sectional area flow rates may include a range of 2 to 3,000  $\text{gpm}/\text{ft}^2$  or more (0.0076 to  $11.36 \text{ m}^3/\text{m}^2$ ), with a flow velocity range of 0.002 to 20  $\text{ft}/\text{sec}$  (0.0006 to 6.1  $\text{m}/\text{sec}$ ).

[0082] A homogenous heterocyclic catalyst is preferably utilized in the catholyte. The homogenous heterocyclic catalyst may include, for example, one or more of 4-hydroxy pyridine, adenine, a heterocyclic amine containing sulfur, a heterocyclic amine containing oxygen, an azole, a benzimidazole, a bipyridine, furan, an imidazole, an imidazole related species with at least one five-member ring, an indole, a lutidine, methylimidazole, an oxazole, phenanthroline, pterin, pteridine, a pyridine, a pyridine related species with at least one six-member ring, pyrrole, quinoline, or a thiazole, and mixtures thereof.

[0083] Preferred anolytes for the system include alkali metal hydroxides, such as KOH, NaOH, LiOH; ammonium hydroxide; inorganic acids such as sulfuric, phosphoric, and the like; organic acids such as methanesulfonic acid; non-aqueous and aqueous solutions; alkali halide salts, such as the chlorides, bromides, and iodine types such as NaCl, NaBr, LiBr, and NaI; and acid halides such as HCl, HBr and HI. The acid halides and alkali halide salts will produce for example chlorine, bromine, or iodine as a halide gas or as dissolved aqueous products from the anolyte compartment. Methanol or other hydrocarbon non-aqueous liquids can also be used, and would form some oxidized organic products from the anolyte. Selection of the anolyte would be determined by the process chemistry product and requirements for lowering the overall operating cell voltage. For example, the formation of bromine at the anode requires a significantly lower anode voltage potential than chlorine formation, and iodine is even lower than that of bromine. This allows for a significant power cost savings in the operation of both of the electrochemical units when bromine is generated in the anolyte. The formation of a halogen, such as bromine, in the anolyte may then be used in an external reaction to produce other compounds, such as reactions with alkanes to form bromoethane, which may then be converted to an alcohol, such as ethanol, or an alkene, such as ethylene, and the halogen acid byproduct from the reaction can be recycled back to the electrochemical cell anolyte.

[0084] Operation of the electrolyzer catholyte at a higher operating pressure may allow more carbon dioxide to dissolve in the aqueous electrolyte than at lower pressures (e.g., ambient pressures). Electrochemical cells may operate at pressures up to about 20 to 30 psig in multi-cell stack designs, although with modifications, they could operate at up to 100 psig. The electrolyzer anolyte may also be operated in the



same pressure range to minimize the pressure differential on the membrane separating the two electrode compartments. Special electrochemical designs are required to operate electrochemical units at higher operating pressures up to about 60 to 100 atmospheres or greater, which is in the liquid CO<sub>2</sub> and supercritical CO<sub>2</sub> operating range.

**[0085]** In a particular implementation, a portion of the catholyte recycle stream may be separately pressurized using a flow restriction with backpressure or using a pump, with CO<sub>2</sub> injection, such that the pressurized stream is then injected into the catholyte compartment of the electrolyzer. Such a configuration may increase the amount of dissolved CO<sub>2</sub> in the aqueous solution to improve the conversion yield.

**[0086]** Catholyte and anolyte operating temperatures preferably range from -10 to 95° C., more preferably 5 to 60° C. The minimum operating temperature will be limited to the electrolytes used and their freezing points. In general, the lower the temperature, the higher the solubility of CO<sub>2</sub> in the aqueous solution phase of the electrolyte, and would help in obtaining higher conversion and current efficiencies. A consideration for lower operating temperatures is that the operating electrolyzer cell voltages may be higher, so an optimization may be required to produce the chemicals at the lowest operating cost.

**[0087]** The electrochemical cell design may include a zero gap, flow-through design with a recirculating catholyte electrolyte with various high surface area cathode materials. Other designs include: flooded co-current packed and trickle bed designs with the various high surface area cathode materials, bipolar stack cell designs, and high pressure cell designs.

**[0088]** Anodes for use in the electrochemical system may depend on various system conditions. For acidic anolytes and to oxidize water to generate oxygen and hydrogen ions, the anode may include a coating, with preferred electrocatalytic coatings including precious metal oxides, such as ruthenium and iridium oxides, as well as platinum, rhodium, and gold and their combinations as metals and oxides deposited on valve metal substrates, such as titanium, tantalum, zirconium, and niobium. For other anolytes, such as alkaline or hydroxide electrolytes, the anode made include carbon, cobalt oxides, stainless steels, nickel, and their alloys and combinations which may be stable as anodes suitable under alkaline conditions.

**[0089]** As described herein, the electrochemical system may employ a membrane positioned between the anode compartment and the cathode compartment. Cation ion exchange type membranes are preferred, especially those that have a high rejection efficiency to anions, for example perfluorinated sulfonic acid based ion exchange membranes such as DuPont Nafion® brand unreinforced types N117 and N120 series, more preferred PTFE fiber reinforced N324 and N424 types, and similar related membranes manufactured by Japanese companies under the supplier trade names such as Flemion®. Other multi-layer perfluorinated ion exchange membranes used in the chlor alkali industry have a bilayer construction of a sulfonic acid based membrane layer bonded to a carboxylic acid based membrane layer, which efficiently operates with an anolyte and catholyte above a pH of about 2 or higher. These membranes have a much higher anion rejection efficiency. These are sold by DuPont under their Nafion® trademark as the N900 series, such as the N90209, N966, N982, and the 2000 series, such as the N2010, N2020, and N2030 and all of their types and subtypes. Hydrocarbon

based membranes, which are made from various cation ion exchange materials can also be used if the anion rejection is not as critical, such as those sold by Sybron under their trade name Ionac®, AGC Engineering (Asahi Glass) under their Selemion® trade name, and Tokuyama Soda, among others available on the market.

**[0090]** Example Electrolyzer Design

**[0091]** The electrolyzer design used in laboratory examples may incorporate various thickness high surface area cathode structures using added spacer frames and also provide the physical contact pressure for the electrical contact to the cathode current conductor backplate.

**[0092]** An electrochemical bench scale cell with an electrode projected area of about 108 cm<sup>2</sup> was used for much of the bench scale test examples. The electrochemical cell was constructed consisting of two electrode compartments machined from 1.0 inch (2.54 cm) thick natural polypropylene. The outside dimensions of the anode and cathode compartments were 8 inches (20.32 cm) by 5 inches (12.70 cm) with an internal machined recess of 0.375 inches (0.9525 cm) deep and 3.0 inches (7.62 cm) wide by 6 inches (15.24 cm) tall with a flat gasket sealing area face being 1.0 inches (2.52 cm) wide. Two holes were drilled equispaced in the recess area to accept two electrode conductor posts that pass through the compartment thickness, and having two 0.25 inch (0.635 cm) drilled and tapped holes to accept a plastic fitting that passes through 0.25 inch (0.635 cm) conductor posts and seals around it to not allow liquids from the electrode compartment to escape to the outside. The electrode frames were drilled with an upper and lower flow distribution hole with 0.25 inch pipe threaded holes with plastic fittings installed to the outside of the cell frames at the top and bottom of the cells to provide flow into and out of the cell frame, and twelve 0.125 inch (0.3175 cm) holes were drilled through a 45 degree bevel at the edge of the recess area to the upper and lower flow distribution holes to provide an equal flow distribution across the surface of the flat electrodes and through the thickness of the high surface area electrodes of the compartments.

**[0093]** For the anode compartment cell frames, an anode with a thickness of 0.060 inch (0.1524 cm) and 2.875 inch (7.3025 cm) width and 5.875 inch (14.9225 cm) length with two 0.25 inch (0.635 cm) titanium diameter conductor posts welded on the backside were fitted through the two holes drilled in the electrode compartment recess area. The positioning depth of the anode in the recess depth was adjusted by adding plastic spacers behind the anode, and the edges of the anode to the cell frame recess were sealed using a medical grade epoxy. The electrocatalyst coating on the anode was a Water Star WS-32, an iridium oxide based coating on a 0.060 inch (0.1524 cm) thick titanium substrate, suitable for oxygen evolution in acids. In addition, the anode compartment also employed an anode folded screen (folded three times) that was placed between the anode and the membrane, which was a 0.010 inch (0.0254 cm) thick titanium expanded metal material from DeNora North America (EC626), with an iridium oxide based oxygen evolution coating, and used to provide a zero gap anode configuration (anode in contact with membrane), and to provide pressure against the membrane from the anode side which also had contact pressure from the cathode side.

**[0094]** For the cathode compartment cell frames, 316L stainless steel cathodes with a thickness of 0.080 inch (0.2032 cm) and 2.875 inch (7.3025 cm) width and 5.875 inch (14.9225 cm) length with two 0.25 inch (0.635 cm) diameter



316L SS conductor posts welded on the backside were fitted through the two holes drilled in the electrode compartment recess area. The positioning depth of the cathode in the recess depth was adjusted by adding plastic spacers behind the cathode, and the edges of the cathode to the cell frame recess were sealed using a fast cure medical grade epoxy.

**[0095]** A copper bar was connected between the two anode posts and the cathode posts to distribute the current to the electrode back plate. The cell was assembled and compressed using 0.25 inch (0.635 cm) bolts and nuts with a compression force of about 60 in-lbs force. Neoprene elastomer is gaskets (0.0625 inch (0.159 cm) thick) were used as the sealing gaskets between the cell frames, frame spacers, and the membranes.

#### Example 1

**[0096]** The above cell was assembled with a 0.010 inch (0.0254 cm) thickness indium foil mounted on the 316L SS back conductor plate using a conductive silver epoxy. A multi-layered high surface area cathode, comprising an electrolessly applied indium layer of about 1 micron thickness that was deposited on a previously applied layer of electroless tin with a thickness of about 25 micron thickness onto a woven copper fiber substrate. The base copper fiber structure was a copper woven mesh obtained from an on-line internet supplier, PestMall.com (Anteater Pest Control Inc.). The copper fiber dimensions in the woven mesh had a thickness of 0.0025 inches (0.00635 cm) and width of 0.010 inches (0.0254 cm). The prepared high surface area cathode material was folded into a pad that was 1.25 inches (3.175 cm) thick and 6 inches (15.24 cm) high and 3 inches (7.62 cm) wide, which filled the cathode compartment dimensions and exceeded the adjusted compartment thickness (adding spacer) which was 0.875 inches (2.225 cm) by about 0.25 inches (0.635 cm). The prepared cathode had a calculated surface area of about 3,171 cm<sup>2</sup>, for an area about 31 times the flat cathode plate area, with a 91% void volume, and specific surface area of 12.3 cm<sup>2</sup>/cm<sup>3</sup>. The cathode pad was compressible, and provided the spring force to make contact with the cathode plate and the membrane. Two layers of a very thin (0.002 inches thick) plastic screen with large 0.125 inch (0.3175 cm) holes were installed between the cathode mesh and the Nafion® 324 membrane. Neoprene gaskets (0.0625 inch (0.159 cm) thick) were used as the sealing gaskets between the cell frames and the membranes. The electrocatalyst coating on the anode in the anolyte compartment was a Water Star WS-32, an iridium oxide based coating, suitable for oxygen evolution in acids. In addition, the anode compartment also employed a three-folded screen that was placed between the anode and the membrane, which was a 0.010 inch (0.0254 cm) thick titanium expanded metal material from DeNora North America (EC626), with an iridium oxide based oxygen evolution coating, and used to provide a zero gap anode configuration (anode in contact with membrane), and to provide pressure against the membrane from the anode side which also had contact pressure from the cathode side.

**[0097]** The cell assembly was tightened down with stainless steel bolts, and mounted into the cell station, which has the same configuration as shown in FIG. 1 with a catholyte disengager, a centrifugal catholyte circulation pump, inlet cell pH and outlet cell pH sensors, a temperature sensor on the outlet solution stream. A 5 micron stainless steel frit filter was used to sparge carbon dioxide into the solution into the

catholyte disengager volume to provide dissolved carbon dioxide into the recirculation stream back to the catholyte cell inlet.

**[0098]** The anolyte used was a dilute 5% by volume sulfuric acid solution, made from reagent grade 98% sulfuric acid and deionized water.

**[0099]** In this test run, the system was operated with a catholyte composition containing 0.4 molar potassium sulfate aqueous with 2 gm/L of potassium bicarbonate added, which was sparged with carbon dioxide to an ending pH of 6.60.

**[0100]** Operating Conditions:

Batch Catholyte Recirculation Run

Anolyte Solution: 0.92 M H<sub>2</sub>SO<sub>4</sub>

Catholyte Solution: 0.4 M K<sub>2</sub>SO<sub>4</sub>, 0.14 mM KHCO<sub>3</sub>

**[0101]** Catholyte flow rate: 2.5 LPM

Catholyte flow velocity: 0.08 ft/sec

Applied cell current: 6 amps (6,000 mA)

Catholyte pH range: 5.5-6.6, controlled by periodic additions of potassium bicarbonate to the catholyte solution recirculation loop. Catholyte pH declines with time, and is controlled by the addition of potassium bicarbonate.

**[0102]** Results:

Cell voltage range: 3.39-3.55 volts (slightly lower voltage when the catholyte pH drops)

Run time: 6 hours

Formate Faradaic yield: Steady between 32-35%, calculated taking samples periodically. See FIG. 7.

Final formate concentration: 9,845 ppm

#### Example 2

**[0103]** The same cell as in Example 1 was used with the same cathode, which was only rinsed with water while in the electrochemical cell after the run was completed and then used for this run.

**[0104]** In this test run, the system was operated with a catholyte composition containing 0.375 molar potassium sulfate aqueous with 40 gm/L of potassium bicarbonate added, which was sparged with carbon dioxide to an ending pH of 7.05.

**[0105]** Operating Conditions:

Batch Catholyte Recirculation Run

Anolyte Solution: 0.92 M H<sub>2</sub>SO<sub>4</sub>

Catholyte Solution: 0.4 M K<sub>2</sub>SO<sub>4</sub>, 0.4 M KHCO<sub>3</sub>

**[0106]** Catholyte flow rate: 2.5 LPM

Catholyte flow velocity: 0.08 ft/sec

Applied cell current: 6 amps (6,000 mA)

Catholyte pH range: Dropping from 7.5 to 6.75 linearly with time during the run.

**[0107]** Results:

Cell voltage range: 3.40-3.45 volts

Run time: 5.5 hours

Formate Faradaic yield: Steady at 52% and slowly declining with time to 44% as the catholyte pH dropped. See FIG. 8.

Final formate concentration: 13,078 ppm



## Example 3

**[0108]** The same cell as in Examples 1 and 2 was used with the same cathode, which was only rinsed with water while in the electrochemical cell after the run was completed and then used for this run.

**[0109]** In this test run, the system was operated with a catholyte composition containing 0.200 molar potassium sulfate aqueous with 40 gm/L of potassium bicarbonate added, which was sparged with carbon dioxide to an ending pH of 7.10.

**[0110]** Operating Conditions:

Batch Catholyte Recirculation Run

Anolyte Solution: 0.92 M H<sub>2</sub>SO<sub>4</sub>

Catholyte Solution: 0.2 M K<sub>2</sub>SO<sub>4</sub>, 0.4 M KHCO<sub>3</sub>

**[0111]** Catholyte flow rate: 2.5 LPM

Catholyte flow velocity: 0.08 ft/sec

Applied cell current: 9 amps (9,000 mA)

Catholyte pH range: Dropping from 7.5 to 6.65 linearly with time during the run, and then additional solid KHCO<sub>3</sub> was added to the catholyte loop in 10 gm increments at the 210, 252, and 290 minute time marks which brought the pH back up to about a pH of 7 for the last part of the run.

**[0112]** Results:

Cell voltage range: 3.98-3.80 volts

Run time: 6.2 hours

Formate Faradaic yield: 75% declining to 60% at a pH of 6.65, and then increasing to 75% upon the addition of solid potassium bicarbonate to the catholyte to the catholyte loop in 10 gm increments at the 210, 252, and 290 minute time marks and slowly declining down with time 68% as the catholyte pH dropped to 6.90. See FIG. 9.

Final formate concentration: 31,809 ppm.

## Example 4

**[0113]** The same cell as in Examples 1, 2, and 3 was used with the same cathode, which was only rinsed with water while in the electrochemical cell after the run was completed and then used for this run.

**[0114]** In this test run, the system was operated with a catholyte composition containing 1.40 molar potassium bicarbonate (120 gm/L KHCO<sub>3</sub>), which was sparged with carbon dioxide to an ending pH of 7.8.

**[0115]** Operating Conditions:

Batch Catholyte Recirculation Run

Anolyte Solution: 0.92 M H<sub>2</sub>SO<sub>4</sub>

Catholyte Solution: 1.4 M KHCO<sub>3</sub>

**[0116]** Catholyte flow rate: 2.6 LPM

Catholyte flow velocity: 0.09 ft/sec

Applied cell current: 11 amps (11,000 mA)

Catholyte pH range: Dropping from around 7.8 linearly with time during the run to a final pH of 7.48

**[0117]** Results:

Cell voltage range: 3.98-3.82 volts

Run time: 6 hours

Formate Faradaic yield: 63% and settling down to about 54-55%. See FIG. 10.

Final formate concentration: 29,987 ppm.

## Prophetic Example 5

**[0118]** This example contemplates separation of product potassium formate from potassium carbonate/bicarbonate supporting electrolyte by membrane nano-filtration (NF) (FIG. 10). The test would involve two commercial NF membranes. The feed solution would comprise 1.2M KHCO<sub>3</sub>+0.6M K-formate and its pH would be adjusted to 7, 9, and 11 for three separate runs (for each membrane).

**[0119]** All NF tests would be performed in GE-Osmonic Sepa permeator (active membrane area of 0.0137 m<sup>2</sup>) at applied pressure of 40 bar (580 psig) and 50° C. During each run 3 liters of feed solution would be passed through and the permeate would be collected into a measuring cylinder (to determine volume) and the elapsed time recorded. The permeate would later be analyzed for total carbonate (HCO<sub>3</sub><sup>-</sup>+CO<sub>3</sub><sup>2-</sup>) and formate. From such data, the permeability (in L/m<sup>2</sup> h bar) and solute rejections (in %) would be calculated as follows:

$$\text{Permeability} = \frac{\text{volume collected (L)}}{\text{membrane area(m}^2\text{)} \times \text{elapsed time(h)}}$$

$$\% \text{ Rejection} = \frac{[S]_{\text{Feed}} - [S]_{\text{Permeate}}}{[S]_{\text{Feed}}} \times 100$$

Where [S] denotes molar concentration of solute that could be either formate or total carbonate.

**[0120]** Expected results are summarized below:

**[0121]** GE-Desal DK Membrane

Feed pH	% Rejection		Permeability L/m <sup>2</sup> h bar
	Total carbonate	Formate	
7	11.4	2.2	1.72
9	30.3	-9.7	1.07
11	81.8	-46.3	0.36

**[0122]** Dow-Filmtec NF270 Membrane

Feed pH	% Rejection		Permeability L/m <sup>2</sup> h bar
	Total carbonate	Formate	
7	11.0	2.6	1.91
9	29.5	-5.4	1.20
11	80.1	-43.8	0.44

## Prophetic Example 6

**[0123]** A single permeation test could be performed with DK membrane, using a formate-enriched Feed solution comprising 1.2M KHCO<sub>3</sub>+1.2M K-formate. The test could be done at pH 11 and all other conditions would be as in the above Example 1.

**[0124]** Such a test would likely give 79.9% and -33.8% rejection for total carbonate and formate, respectively. The permeability would be 0.32 L/m<sup>2</sup> h bar.



## Example 7

**[0125]** The same cell as in Examples 1, 2, and 3 was used, except for using 701 gm of tin shot (0.3-0.6 mm diameter) media with an electroless plated indium coating as the cathode. The cathode compartment thickness was 0.875 inches.

**[0126]** In this test run, the system was operated with a catholyte composition containing 1.40 molar potassium bicarbonate (120 gm/L  $\text{KHCO}_3$ ), which was sparged with carbon dioxide to an ending pH of 8.0

**[0127]** The cell was operated in a batch condition with no overflow for the first 7.3 hrs, and then a 1.40 molar potassium bicarbonate feed was introduced into the catholyte at a rate of about 1.4 mL/min, with the overflow collected and measured, and a sample of the loop was collected for formate concentration analysis.

**[0128]** Operating Conditions:

Batch Catholyte Recirculation Run

Anolyte Solution: 0.92 M  $\text{H}_2\text{SO}_4$

Catholyte Solution: 1.4 M  $\text{KHCO}_3$

**[0129]** Catholyte flow rate: 3.2 LPM

Applied cell current: 6 amps (6,000 mA)

Catholyte pH range: Dropping slowly from around a pH of 8 linearly with time during the run to a final pH of 7.50

**[0130]** Results:

Cell voltage range: 3.98-3.82 volts

Run time Batch mode: 7.3 hours

Feed and product overflow: 7.3 hours to end of run at 47 hours.

**[0131]** The formate Faradaic efficiency was between 42% and 52% during the batch run period where the formate concentration went up to 10,490 ppm. During the feed and overflow period, the periodic calculated efficiencies varied between 32% and 49%. The average conversion efficiency was about 44%. The formate concentration varied between 10,490 and 48,000 ppm during the feed and overflow period. The cell voltage began at around 4.05 volts, ending up at 3.80 volts.

## Example 8

**[0132]** Electrolyses were performed using a 3-compartment glass cell of roughly 80 mL total volume. The cell was constructed to be gas tight with Teflon bushings. The compartments were separated by 2 glass frits. A 3-electrode assembly was employed. One compartment housed the working electrode and the reference electrode (Accumet silver/silver chloride) which contained the aqueous electrolyte and catalyst as stated. The center compartment also contained the electrolyte and catalyst solution as stated. The third compartment was filled with 0.5 molar  $\text{K}_2\text{SO}_4$  aqueous electrolyte solution sparged with  $\text{CO}_2$  with a pH of about 4.5 and housed the counter electrode (TELPRO (Stafford, Tex.)—Mixed Metal Oxide Electrode). The working electrode compartment was purged with carbon dioxide during the experiment. The solutions were measured by ion chromatography for formic acid, analyzing the solution before (a blank) and after electrolysis. The tests were conducted under potentiometric conditions using a 6 channel Arbin Instruments MSTAT, operating at -1.46 or -1.90 volts vs. an SCE reference electrode for about 1.5 hrs.

Cathode Evaluated	Experiment Designation	Formate Produced (ppm)	Formate Yield %	Applied Potential (volts)	Current (ma)	Time (hrs)
Electroplated indium on tin foil	DK80	1,818	75.8	-1.9	50	1.5
Electroplated indium on tin foil	DK82	1,956	64.0	-1.9	58.5	1.5
Untreated tin foil	DK80	1,260	54.3	-1.9	44.5	1.5
Electroplated indium on copper foil	DK83	1,887	31.7	-1.9	123	1.5
Tin foil (untreated)	DK80	604	18.0	-1.9	54.8	1.5
Copper screen with electroless indium coating	DK79	1,813	30.6	-1.46	97.9	1.5
Copper screen with electroless indium annealed at 200° C.	DK78	1,387	43.9	-1.46	63.6	1.5

## Example 9

**[0133]** The same cell as in Examples 1, 2, and 3 was used, except for using 890.5 gm of tin shot (3 mm diameter) media and with a tin foil coating as the cathode. The cathode compartment thickness was 1.25 inches and the system was operated in a batch mode with no feed input. Carbon dioxide was sparged to saturate the solution in the catholyte disengager.

**[0134]** Packed Tin Bed Cathode Detail:

Weight: 890.5 gm tin shot

Tin shot: 3 mm average size

Total compartment volume: 369  $\text{cm}^3$

Calculated tin bead surface area: 4,498  $\text{cm}^2$

Calculated packed bed cathode specific surface area: 12.2  $\text{cm}^2/\text{cm}^3$

Calculated packed bed void volume: 34.6%

**[0135]** In this test run, the system was operated with a catholyte composition containing 1.40 molar potassium bicarbonate (120 gm/L  $\text{KHCO}_3$ ), which was sparged with  $\text{CO}_2$  to an ending pH of about 8.0

**[0136]** The cell was operated in a batch condition with no overflow and a sample of the catholyte loop was collected for formate concentration analysis periodically.

**[0137]** Operating Conditions:

**[0138]** Batch Catholyte Recirculation Run

**[0139]** Anolyte Solution: 0.92 M  $\text{H}_2\text{SO}_4$

**[0140]** Catholyte Solution: 1.4 M  $\text{KHCO}_3$

**[0141]** Catholyte flow rate: 3.0 LPM (upflow)

**[0142]** Catholyte flow velocity: 0.068 ft/sec

**[0143]** Applied cell current: 6 amps (6,000 mA)

**[0144]** Catholyte pH range: Increasing slowly from around a pH of 7.62 linearly with time during the run to a final pH of 7.73

**[0145]** Results:

Cell voltage range: Started at 3.84 volts, and slowly declined to 3.42 volts

Run time: Batch mode, 19 hours



[0146] The formate Faradaic efficiency started at about 65% and declined after 10 hours to 36% and to about 18.3% after 19 hours. The final formate concentration ended up at 20,500 ppm at the end of the 19 hour run. See FIGS. 11 and 12.

#### Example 10

[0147] The same cell as in Examples 1, 2, and 3 was used, except for using 805 gm of indium coated tin shot (3 mm diameter) media and with a 0.010 inch (0.0254 cm) thickness indium foil mounted on the 316L SS back conductor plate using a conductive silver epoxy as the cathode. The cathode compartment thickness was 1.25 inches and the system was operated in a batch mode with no feed input. Carbon dioxide was sparged to saturate the solution in the catholyte disengager. The tin shot was electrolessly plated with indium in the same method as used in Examples 1-4 on the tin-coated copper mesh. The indium coating was estimated to be about 0.5-1.0 microns in thickness.

[0148] Indium-Coated Tin Shot Packed Bed Cathode Detail:

Weight: 890.5 gm, indium coating on tin shot

Indium coated tin shot: 3 mm average size

Total compartment volume: 369 cm<sup>3</sup>

Calculated tin bead surface area: 4498 cm<sup>2</sup>

Packed bed cathode specific surface area: 12.2 cm<sup>2</sup>/cm<sup>3</sup>

Packed bed void volume: 34.6%

[0149] In this test run, the system was operated with a catholyte composition containing 1.40 molar potassium bicarbonate (120 gm/L KHCO<sub>3</sub>), which was sparged with CO<sub>2</sub> to an ending pH of about 8.0

[0150] The cell was operated in a batch condition with no overflow and a sample of the catholyte loop was collected for formate concentration analysis periodically.

[0151] Operating Conditions:

[0152] Batch Catholyte Recirculation Run

[0153] Anolyte Solution: 0.92 M H<sub>2</sub>SO<sub>4</sub>

[0154] Catholyte Solution: 1.4 M KHCO<sub>3</sub>

[0155] Catholyte flow rate: 3.0 LPM (upflow)

[0156] Catholyte flow velocity: 0.068 ft/sec

[0157] Applied cell current: 6 amps (6,000 mA)

[0158] Catholyte pH range: Decreased slowly from around a pH of 7.86 linearly with time during the run to a final pH of 5.51

[0159] Results:

Cell voltage range: Started at 3.68 volts, and slowly declined to 3.18 volts

Run time Batch mode, 24 hours

[0160] The formate Faradaic efficiency started at about 100% and varied between 60% to 85%, ending at about 60% after 24 hours. The final formate concentration ended up at about 60,000 ppm at the end of the 24 hour run. Dilution error of the samples at the high formate concentrations may have provided the variability seen in the yield numbers. See FIGS. 13 and 14.

#### Example 11

[0161] The same cell as in Examples 1, 2, and 3 was used with a newly prepared indium on tin electrocatalyst coating on a copper mesh cathode. The prepared cathode had calculated surface areas of about 3,171 cm<sup>2</sup>, for an area about 31 times the flat cathode plate area, with a 91% void volume, and specific surface area of 12.3 cm<sup>2</sup>/cm<sup>3</sup>.

[0162] In this test run, the system was operated with a catholyte composition containing 1.40 M potassium bicarbonate (120 gm/L KHCO<sub>3</sub>), which was sparged with CO<sub>2</sub> to an ending pH of 7.8 before being used.

[0163] The cells were operated in a recirculating batch mode for the first 8 hours of operation to get the catholyte formate ion concentration up to about 20,000 ppm, and then a fresh feed of 1.4 M potassium bicarbonate was metered into the catholyte at a feed rate of about 1.2 mL/min. The overflow volume was collected and volume measured, and the overflow and catholyte loop sample were sampled and analyzed for formate by ion chromatography.

[0164] Operating Conditions:

Cathode: Electroless indium on tin on a copper mesh substrate Continuous Feed with Catholyte Recirculation Run—11.5 days

Anolyte Solution: 0.92 M H<sub>2</sub>SO<sub>4</sub>

Catholyte Solution: 1.4 M KHCO<sub>3</sub>

[0165] Catholyte flow rate: 3.2 LPM

Catholyte flow velocity: 0.09 ft/sec

Applied cell current: 6 amps (6,000 mA)

[0166] Results:

[0167] Cell voltage versus time: FIG. 15 illustrates results of cell voltage versus time, displaying a stable operating voltage of about 3.45 volts over the 11.5 days after the initial start-up.

[0168] Continuous Run time: 11.5 days

[0169] Formate Concentration Versus Time: FIG. 16 shows results of the formate concentration versus time.

[0170] FIG. 17 shows a scanning electron microscope (SEM) image of the electroless indium coating on tin-plated copper fiber cathode after 11.5 days of continuous electrolysis. (FIG. 18 shows an SEM image of an example electroless indium coating on a treated carbon fiber material, which was not used in Example 11.)

[0171] Formate Faradaic yield: FIG. 19 illustrates the calculated formate current efficiency versus time measuring the formate yield from the collected samples.

[0172] Final formate concentration: About 28,000 ppm.

[0173] Catholyte pH: FIG. 20 illustrates the catholyte pH change over the 11.5 days, which slowly declined from a pH of 7.8 to a pH value of 7.5. The feed rate was not changed during the run, but could have been slowly increased or decreased to maintain a constant catholyte pH in any optimum operating pH range.

#### Example 12

[0174] The same cell as in Examples 1, 2, and 3 was used with a newly prepared indium on tin electrocatalyst coating on a copper mesh cathode. The prepared cathode had calculated surface areas of about 3,171 cm<sup>2</sup>, for an area about 31 times the flat cathode plate area, with a 91% void volume, and specific surface area of 12.3 cm<sup>2</sup>/cm<sup>3</sup>.

[0175] In this test run, the system was operated with a catholyte composition containing 1.40 M potassium bicarbonate (120 gm/L KHCO<sub>3</sub>), which was sparged with CO<sub>2</sub> to an ending pH of 7.8 before being used.

[0176] The cells were operated in a recirculating batch mode for the first 8 hours of operation to get the catholyte formate ion concentration up to about 20,000 ppm, and then a fresh feed of 1.4 M potassium bicarbonate was metered into the catholyte at a feed rate of about 1.2 mL/min. The overflow volume was collected and volume measured, and the overflow and catholyte loop sample were sampled and analyzed for formate by ion chromatography.



**[0177]** Operating Conditions:

Cathode: Electroless indium on tin on a copper mesh substrate

Continuous Feed with Catholyte Recirculation Run—21 days

Anolyte Solution: 0.92 M H<sub>2</sub>SO<sub>4</sub>

Catholyte Solution: 1.4 M KHCO<sub>3</sub>

**[0178]** Catholyte flow rate: 3.2 LPM

Catholyte flow velocity: 0.09 ft/sec

**[0179]** Applied cell current: 6 amps (6,000 mA)

**[0180]** Results:

**[0181]** Cell voltage versus time: The cell showed a higher operating voltage of about 4.40 volts, higher than all of our other cells, because of an inadequate electrical contact pressure of the cathode against the indium foil conductor back plate. The cell maintained operation for an extended run.

**[0182]** Continuous Run time: 21 days

**[0183]** Formate Faradaic yield: FIG. 21 illustrates calculated formate current efficiency versus time measuring the formate yield from the collected samples. The formate Faradaic current efficiency declined down into the 20% range after 16 days.

**[0184]** Formate Concentration Versus Time: FIG. 22 illustrates results of the formate concentration versus time. On day 21, 0.5 gm of indium (III) carbonate was added to the catholyte while the cell was still operating at the 6 ampere operating rate. The formate concentration in the catholyte operating loop was 11,330 ppm before the indium addition, which increased to 13,400 ppm after 8 hours, and increased to 14,100 ppm after 16 hours when the unit was shut down after 21 days of operation.

**[0185]** Catholyte pH: FIG. 23 illustrates the catholyte pH change over the continuous operation period, which operated in the 7.6 to 7.7 pH range except for an outlier data point near day 16 when the feed pump had stopped pumping. The feed rate was not changed during the run, but could have been increased or decreased to maintain a constant pH operation in an optimum range.

**[0186]** It is believed that the present disclosure and many of its attendant advantages will be understood by the foregoing description, and it will be apparent that various changes may be made in the form, construction and arrangement of the components thereof without departing from the scope and spirit of the disclosure or without sacrificing all of its material advantages. The form herein before described being merely an explanatory embodiment thereof, it is the intention of the following claims to encompass and include such changes.

What is claimed is:

1. A system for electrochemical reduction of carbon dioxide into products, comprising:

a first electrochemical cell including:

a cathode compartment containing a high surface area cathode and a bicarbonate-based catholyte saturated with carbon dioxide, the high surface area cathode including an indium coating and having a void volume of between about 30% to 98%; and

an anode compartment containing an anode and an acidic anolyte,

wherein the electrochemical cell is configured to produce a product upon application of an electrical potential between the anode and the cathode.

2. The system of claim 1 further comprising:

a cation ion exchange membrane positioned between the cathode compartment and the anode compartment.

3. The system of claim 1, wherein the high surface area cathode includes indium deposited on tin.

4. The system of claim 3, wherein the high surface area cathode further includes at least one of a copper substrate or a conductive substrate, the tin layered on the at least one of the copper substrate or the conductive substrate.

5. The system of claim 1, wherein the anode comprises an electrocatalytic coating including at least one of ruthenium oxide, iridium oxide, platinum, a platinum oxide, gold, or a gold oxide.

6. The system of claim 1, wherein the product of the first electrochemical cell includes an alkali metal formate.

7. The system of claim 1, wherein the cathode compartment further contains a homogenous heterocyclic amine catalyst.

8. The system of claim 7, wherein the homogenous heterocyclic amine catalyst is selected from the group consisting of 4-hydroxy pyridine, adenine, a heterocyclic amine containing sulfur, a heterocyclic amine containing oxygen, an azole, a benzimidazole, a bipyridine, a furan, an imidazole, an imidazole related species with at least one five-member ring, an indole, a lutidine, a methylimidazole, an oxazole, a phenanthroline, a pterin, a pteridine, pyridine, a pyridine related species with at least one six-member ring, a pyrrole, a quinoline, or a thiazole, and mixtures thereof.

9. The system of claim 1, further comprising:

a first separator configured to receive an output from the anode compartment, wherein at least a portion of a product of the first separator is recycled to the anode compartment; and

a second separator configured to receive an output from the cathode compartment, wherein at least a portion of a product of the second separator is recycled to the cathode compartment.

10. The system of claim 1, further comprising:

a second electrochemical cell including:

a catholyte compartment comprising a cathode;

an anolyte compartment comprising an anode; and

an ion exchange compartment positioned between the catholyte compartment and the anolyte compartment, the ion exchange compartment including an input port configured to receive the product from the electrochemical cell,

wherein the second electrochemical cell is configured to produce a second product upon application of an electrical potential between the anode and the cathode.

11. The system of claim 10, wherein the second product of the second electrochemical cell includes formic acid.

12. The system of claim 10, wherein the bicarbonate-based catholyte of the first electrochemical cell includes potassium bicarbonate, wherein the product of the first electrochemical cell includes potassium formate, and wherein the second product of the second electrochemical cell includes formic acid.

13. The system of claim 10, further comprising:

a third separator configured to receive an output from the anolyte compartment of the second electrochemical cell, wherein at least a portion of a product of the third separator is recycled to the anolyte compartment of the second electrochemical cell; and



- a fourth separator configured to receive an output from the catholyte compartment of the second electrochemical cell, wherein at least a portion of a product of the fourth separator is recycled to the catholyte compartment of the second electrochemical cell.
- 14.** The system of claim **13**, further comprising:  
a catholyte recycle reactor, the catholyte recycle reactor including an input port configured to receive at least a portion of the product from the fourth separator, wherein at least a portion of a product of the catholyte recycle reactor is recycled to the cathode compartment of the first electrochemical cell.
- 15.** The system of claim **14**, further comprising:  
a carbon dioxide distribution module, the carbon dioxide distribution module configured to receive carbon dioxide from at least a portion of the product of one or more of the first separator, the second separator, the third separator, and the fourth separator, wherein the carbon dioxide distribution module is configured to distribute carbon dioxide to one or more of the cathode compartment of the first electrochemical cell and the catholyte recycle reactor.
- 16.** The system of claim **10**, wherein the second electrochemical cell includes a plurality of bipolar membranes.
- 17.** The system of claim **10**, further comprising:  
a nano-filtration system coupled between the electrochemical cell and the second electrochemical cell, the nano-filtration system configured to receive the product from the first electrochemical cell and to separate at least one of a carbonate or a bicarbonate from an alkali metal formate, the nano-filtration system configured to send the alkali metal formate to the ion exchange compartment of the second electrochemical cell.
- 18.** A system for electrochemical reduction of carbon dioxide into products, comprising:  
an electrolyzer system configured for the reduction of carbon dioxide to an alkali metal formate, the electrolyzer system including:  
an electrolyzer, comprising:  
a first compartment containing an anolyte and an anode;  
a second compartment containing a catholyte and a high surface area cathode, the catholyte including an alkali metal bicarbonate solution saturated with carbon dioxide, the high surface area cathode including an indium coating on tin and having a void volume of between about 30% to 98%, the high surface area cathode configured to reduce the carbon dioxide to the alkali metal formate;  
a cation exchange membrane positioned between the first compartment and the second compartment;  
an anolyte recycle loop configured to recirculate at least a portion of the anolyte;  
a catholyte recycle loop configured to recirculate at least a portion of the catholyte;  
an electrochemical acidification system configured to acidify the alkali metal formate to formic acid, the electrochemical acidification system including:  
an electrochemical acidification unit including:  
a catholyte compartment comprising a cathode;  
an anolyte compartment comprising an anode; and  
an ion exchange compartment positioned between the catholyte compartment and the anolyte compartment, the ion exchange compartment including an input port configured to receive the alkali metal formate from the electrolyzer,  
wherein the electrochemical acidification unit is configured to produce formic acid upon application of an electrical potential between the anode and cathode of electrochemical acidification unit, and wherein said catholyte compartment is configured to produce an alkali metal hydroxide;  
an alkali metal recycle system configured to receive the alkali metal hydroxide, and at least one of at least a portion of carbon dioxide generated from the electrochemical acidification system or at least a portion of residual carbon dioxide from the electrolyzer system, the alkali metal recycle system configured to generate at least a portion of the alkali metal bicarbonate solution fed to the second compartment of the electrolyzer.
- 19.** A high surface area electrode, comprising:  
a substrate including at least one of a metal or carbon, the substrate having a void volume of between about 30% to 98%; and  
an electrocatalyst coating disposed on the surface of the electrode, the electrocatalyst coating covering about 5% to 100% of the electrode surface area, the electrocatalyst coating including indium in an amount of about 5% to 99% by weight.
- 20.** The high surface area electrode of claim **19**, wherein the substrate includes copper.
- 21.** The high surface area electrode of claim **20**, further including:  
a tin coating on the copper substrate.
- 22.** The high surface area electrode of claim **21**, wherein the indium is coated on the tin coating.
- 23.** The high surface area electrode of claim **19**, wherein the electrocatalyst includes indium as a metal alloy.
- 24.** The high surface area electrode of claim **23**, wherein the metal alloy includes indium as an alloy with one or more of Sn, Pb, Hg, Tl, Bi, Cu, and Cd, and alloy mixtures thereof.
- 25.** The high surface area electrode of claim **19**, wherein the electrocatalyst coating further includes one or more of Au, Ag, Zn, Pb, and Pd in an amount of about 5% to 99% by weight.
- 26.** The high surface area electrode of claim **19**, wherein the electrocatalyst coating further includes an oxide of one of or more of Au, Ag, Bi, Cu, Cd, Pb, Pd, Hg, Sn, Tl, Zn, and mixtures thereof.
- 27.** The high surface area electrode of claim **19**, wherein the electrocatalyst coating is disposed as a single layer on the substrate.
- 28.** The high surface area electrode of claim **19**, wherein the electrocatalyst coating is disposed as a plurality of layers on the substrate.
- 29.** The high surface area electrode of claim **28**, wherein the plurality of layers includes at least a first layer deposited on a second layer; the first layer including indium, and the second layer including at least one of Au, Ag, Bi, Cu, Cd, Pb, Pd, Hg, Sn, Tl, Zn, and mixtures thereof.
- 30.** The high surface area electrode of claim **19**, wherein the substrate comprises a specific surface area of about 2 cm<sup>2</sup>/cm<sup>3</sup>.