



US 20130052036A1

(19) **United States**

(12) **Patent Application Publication**
Smith

(10) **Pub. No.: US 2013/0052036 A1**

(43) **Pub. Date: Feb. 28, 2013**

(54) **PIN-FIN ARRAY**

(52) **U.S. Cl. 416/97 R**

(75) **Inventor: Aaron Ezekiel Smith, Simpsonville, SC (US)**

(57) **ABSTRACT**

(73) **Assignee: GENERAL ELECTRIC COMPANY, Schenectady, NY (US)**

(21) **Appl. No.: 13/221,009**

(22) **Filed: Aug. 30, 2011**

Publication Classification

(51) **Int. Cl. F01D 5/18 (2006.01)**

The present application provides an airfoil with a cooling flow therein. The airfoil may include an internal cooling passage, a number of cooling holes in communication with the internal cooling passage, and a number of pin-fins positioned within the internal cooling passage. The pin-fins are arranged with one or more turning openings and one or more guiding openings so as to direct the cooling flow towards the cooling holes.

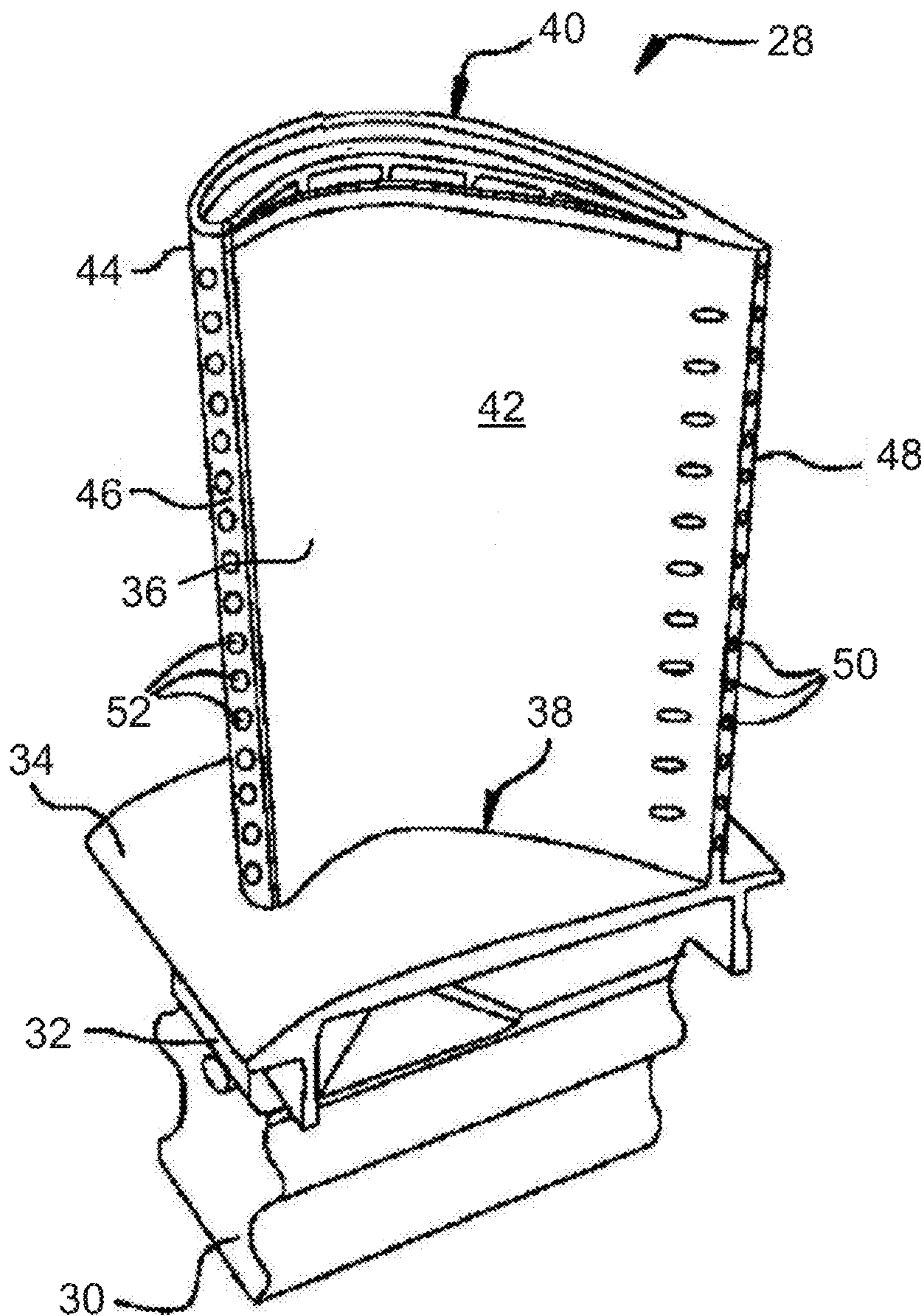

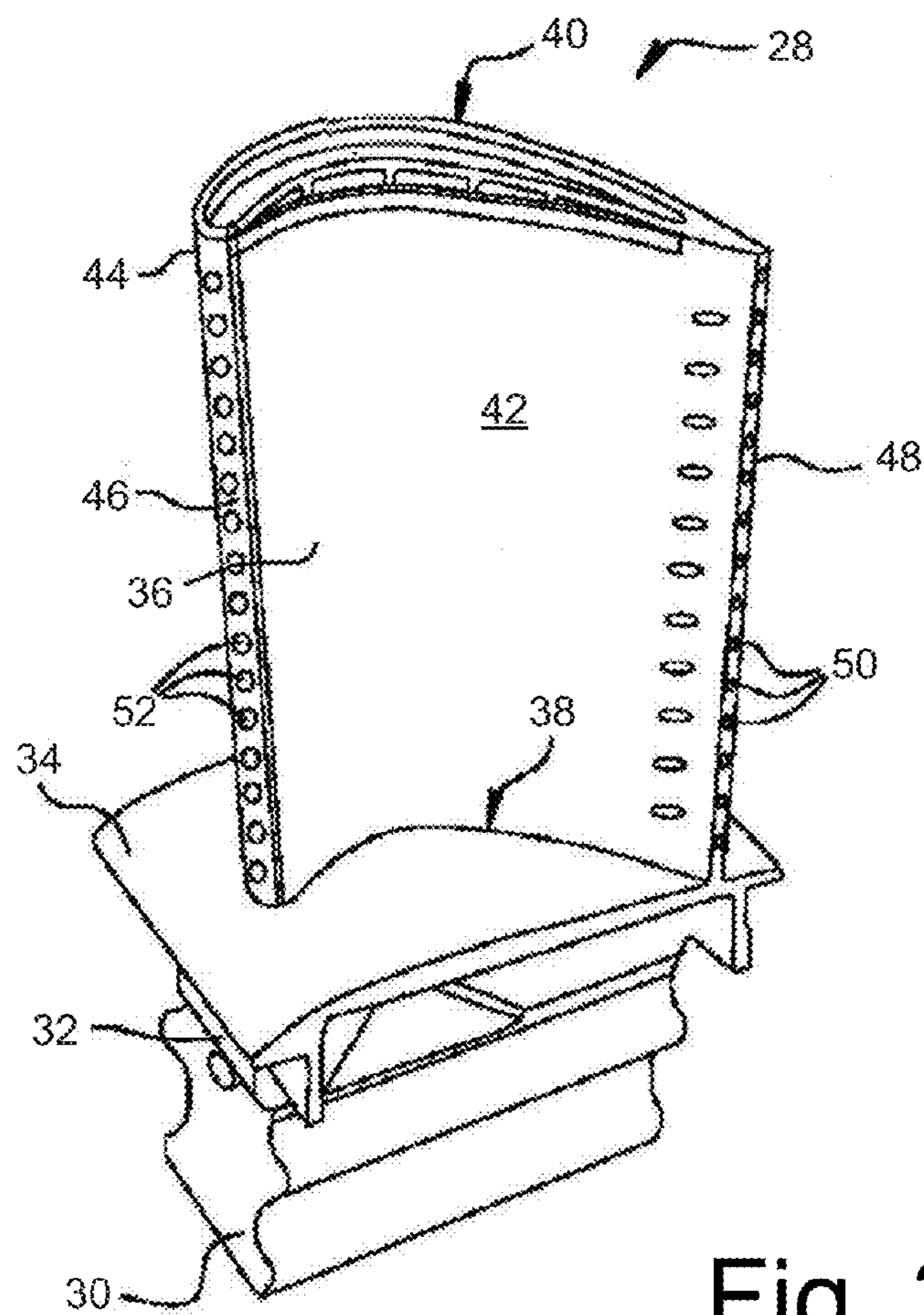
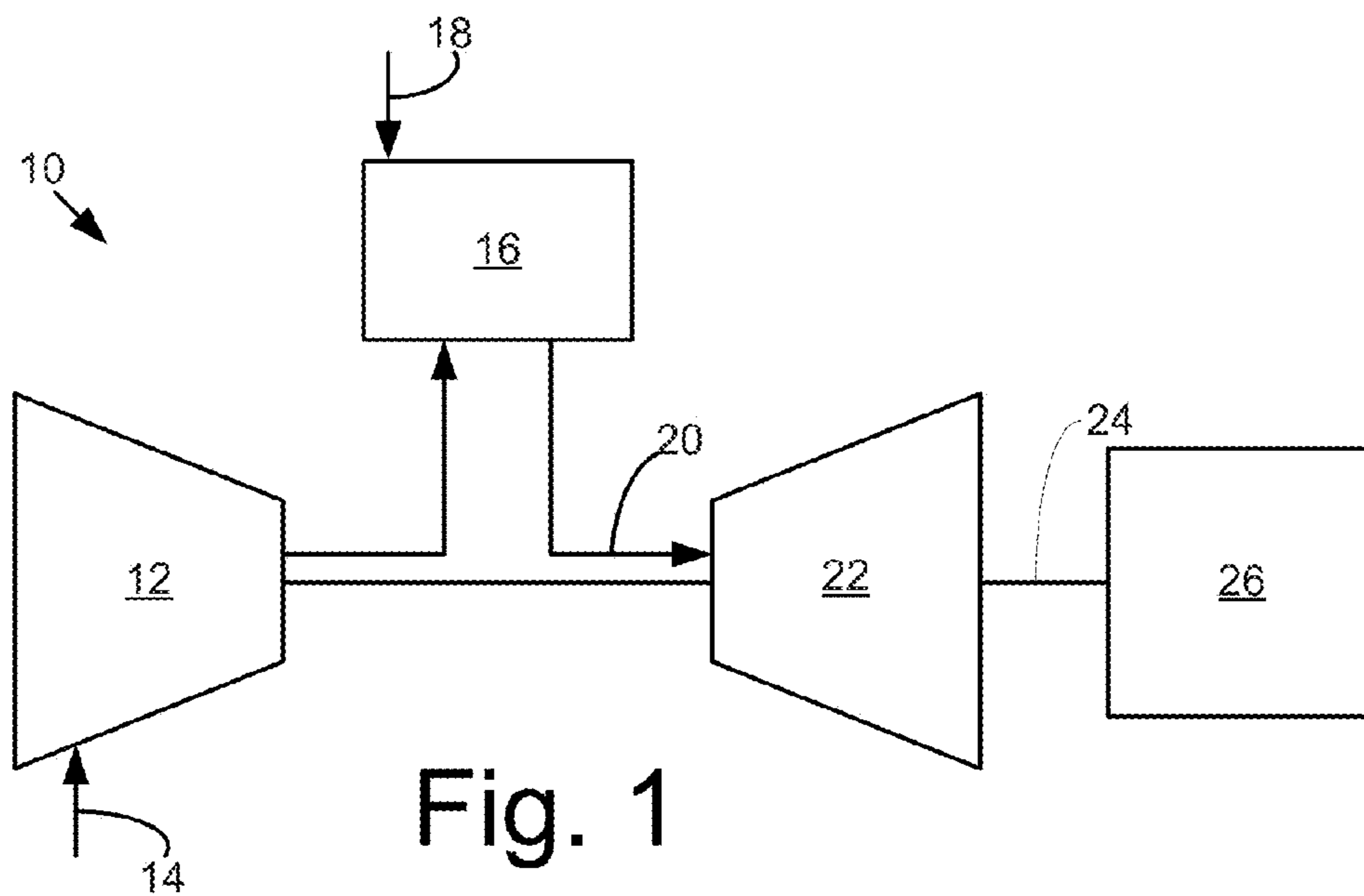

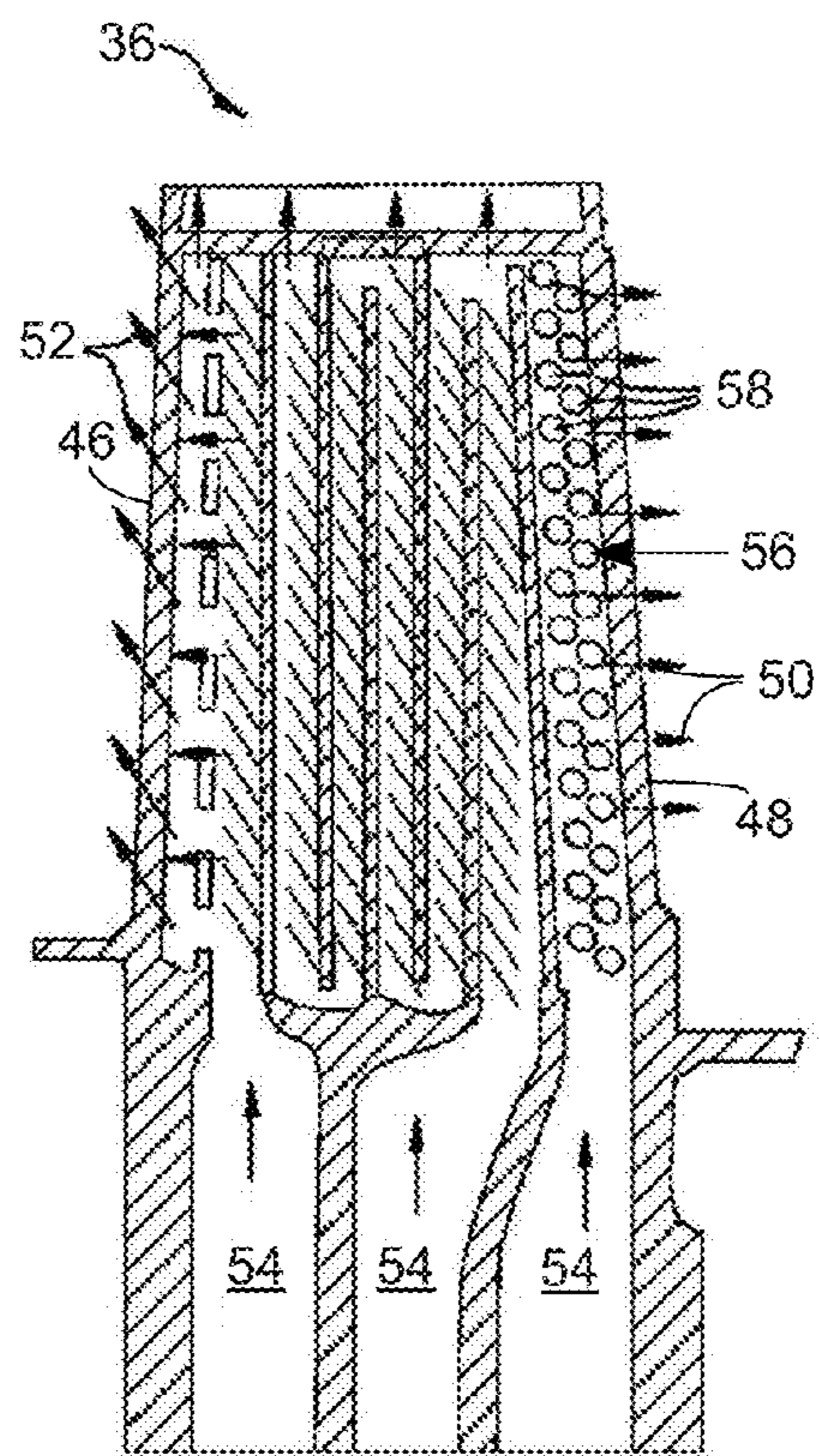

Fig. 3

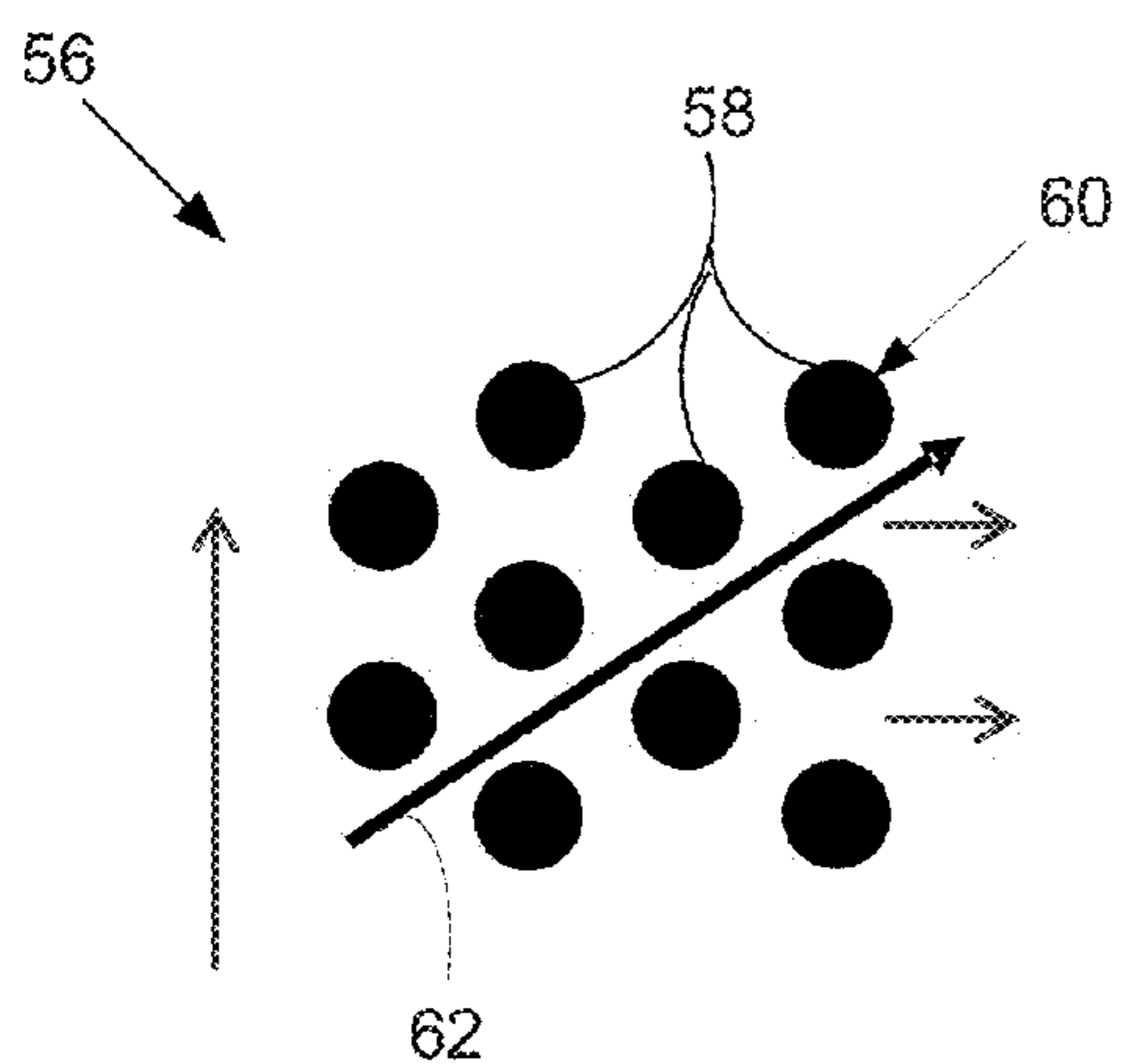

Fig. 4

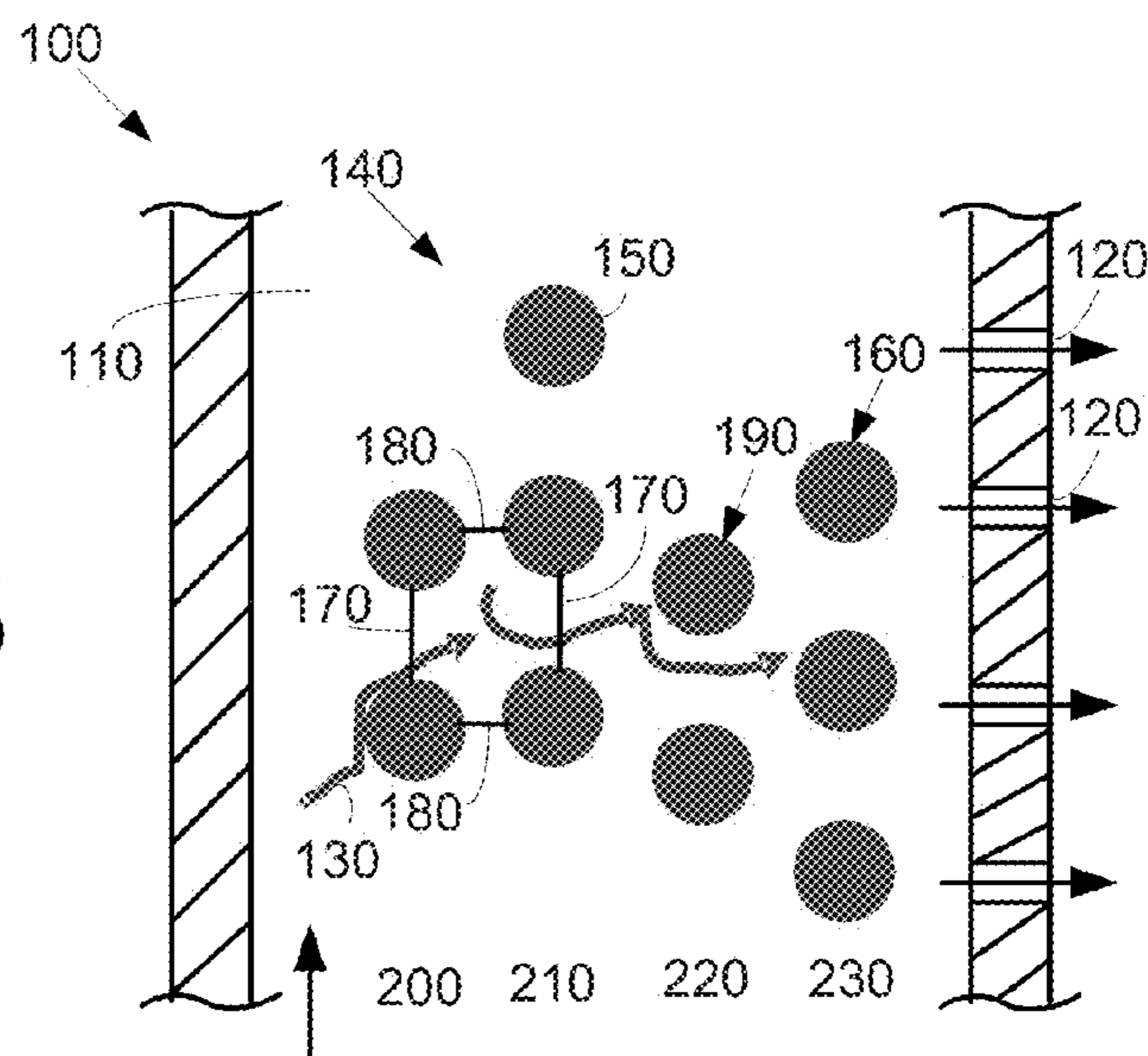

Fig. 5

PIN-FIN ARRAY

TECHNICAL FIELD

[0001] The present application and the resultant patent relate generally to gas turbine engines and more particularly relate to a flow guiding pin-fin array for use in gas turbine airfoils and the like.

BACKGROUND OF THE INVENTION

[0002] A gas turbine includes a number of stages with buckets extending outwardly from a supporting rotor disk. Each bucket includes an airfoil over which combustion gases flow. The airflow must be cooled to withstand the high temperatures produced by the combustion gases. Insufficient cooling may result in undue stress on the airfoil and may lead or contribute to fatigue and/or damage. The airfoil thus is generally hollow with one or more internal cooling flow channels. The internal cooling flow channels may be provided with a cooling air bleed from the compressor or elsewhere. Convective heat transfer may be enhanced between the cooling flow and the internal metal surfaces of the airfoil by the use of pin-fin arrays, turbulators, and the like. The pin-fin arrays or the turbulators create a disruption in a surrounding boundary layer so as to increase heat transfer.

[0003] An airfoil generally has a single cooling flow feed leading to a pin array and multiple outlets. Such a configuration, however, typically results in a flow through the pin array that is at an angle relative to the outlets. This angled flow may lead to a less effective heat transfer therein. Flow straighteners may be used but such add space and complexity to the pin array region.

[0004] There is thus a desire for an airfoil with an improved internal cooling flow scheme with a pin-fin array. Such an improved cooling flow scheme may provide a pin-fin array for more effective heat transfer, better flow control, and lower manufacturing costs.

SUMMARY OF THE INVENTION

[0005] The present application and the resultant patent provide an airfoil with a cooling flow therein. The airfoil may include an internal cooling passage, a number of cooling holes in communication with the internal cooling passage, and a number of pin-fins positioned within the internal cooling passage. The pin-fins are arranged with one or more turning openings and one or more guiding openings so as to direct the cooling flow towards the cooling holes.

[0006] The present application and the resultant patent further provide an airfoil with a cooling flow therein. The airfoil may include an internal cooling passage, a number of cooling holes in communication with the internal cooling passage, and a number of pin-fins positioned within the internal cooling passage in a non-uniform array. The pin-fins are arranged with one or more turning openings and one or more guiding openings in a staggered positioning so as to direct the cooling flow towards the cooling holes.

[0007] The present application and the resultant patent further provide an internal cooling passage with a cooling flow therein. The internal cooling passage may include a number of cooling holes and a number of pin-fins positioned within the internal cooling passage. The pin-fins are arranged with one or more turning openings with a first distance between a first pair of the pin-fins, one or more guiding openings with a

second distance between a second pair of the pin-fins, and wherein the first distance is greater than the second distance.

[0008] These and other features and improvements of the present application and the resultant patent will become apparent to one of ordinary skill in the art upon review of the following detailed description when taken in conjunction with the several drawings and the appended claims.

BRIEF DESCRIPTION OF THE DRAWINGS

[0009] FIG. 1 is a schematic view of a gas turbine engine.

[0010] FIG. 2 is a perspective view of a turbine bucket.

[0011] FIG. 3 is a side cross-sectional view of the turbine bucket of FIG. 2.

[0012] FIG. 4 is a schematic view of a known pin-fin array.

[0013] FIG. 5 is a schematic view of an example of a pin-fin array as may be described herein.

DETAILED DESCRIPTION

[0014] Referring now to the drawings, in which like numerals refer to like elements throughout the several views, FIG. 1 shows a schematic view of gas turbine engine 10 as may be used herein. The gas turbine engine 10 may include a compressor 12. The compressor 12 compresses an incoming flow of air 14. The compressor 12 delivers the compressed flow of air 14 to a combustor 16. The combustor 16 mixes the compressed flow of air 14 with a compressed flow of fuel 18 and ignites the mixture to create a flow of combustion gases 20. Although only a single combustor 16 is shown, the gas turbine engine 10 may include any number of combustors 16. The flow of combustion gases 20 is in turn delivered to a turbine 22. The flow of combustion gases drives the turbine 22 so as to produce mechanical work. The mechanical work produced in the turbine 22 drives the compressor 12 via a shaft 24 and an external load 26 such as an electrical generator and the like.

[0015] The gas turbine engine 10 may use natural gas, various types of syngas, and/or other types of fuels. The gas turbine engine 10 may be any one of a number of different gas turbine engines offered by General Electric Company of Schenectady, N.Y., including, but not limited to, those such as a 7 or a 9 series heavy duty gas turbine engine and the like. The gas turbine engine 10 may have different configurations and may use other types of components. Other types of gas turbine engines also may be used herein. Multiple gas turbine engines, other types of turbines, and other types of power generation equipment also may be used herein together.

[0016] FIG. 2 shows an example of a turbine bucket 28 that may be used with the turbine 22 described above. The turbine bucket 28 preferably may be formed as a one-piece casting of a super alloy. The turbine bucket 28 may include a conventional dovetail attached to a conventional rotor disk. A blade shank 32 extends upwardly from the dovetail 30 and terminates in a platform 34 that projects outwardly from and surrounds the shank 32.

[0017] A hollow airfoil 36 extends outwardly from the platform 34. The airfoil 36 has a root 38 at the junction with the platform 34 and a tip 40 at its outer end. The airfoil 36 has a concave pressure sidewall 42 and a convex suction sidewall 44 joined together at a leading edge 46 and a trailing edge 48. The airfoil 36 may include a number of trailing edge cooling holes 50 and a number of leading edge cooling holes 52. The airfoil 36 and the turbine bucket 28 as a whole are described herein for the purposes of example only. The airfoil 36 and the turbine bucket 28 may have any size or shape suitable for

extracting energy from the flow of combustion gases 20. Other components and other configurations may be used herein.

[0018] FIG. 3 shows a side cross-sectional view of the airfoil 36. As is shown, the airfoil 36 may include a number of internal cooling pathways 54. The airfoil 36 may be air cooled, steam cooled, open circuit, or closed circuit. The leading edge cooling hole 52 may be in communication with one or more of the internal cooling pathways 54. Likewise, the trailing edge cooling holes 50 may be in communication with one or more of the internal cooling pathways 54. One or more of the internal cooling pathways 54 also may include a pin array 56. The pin array 56 may be an array of pin-fins 58. The pin-fins 58 may have any desired size, shape, or configuration. In this example, the pin array 56 is positioned about the trailing edge cooling holes 50. Other types of heat transfer techniques may be used herein.

[0019] FIG. 4 shows an example of the pin array 56. In this example, the pin-fins 58 are arranged in a uniform array 60. As is shown, the pin-fins 58 are arranged with a generally uniform distance between each pin-fin 58. As a result, a cooling flow 62 may flow through the pin array 56 or other type of dump region at an angle relative to the trailing edge cooling holes 50. As described above, such an angle may compromise overall heat transfer.

[0020] FIG. 5 shows a portion of an airfoil 100 as may be described herein. The airfoil 100 includes a number of internal cooling pathways 110 and a number of cooling holes 120 therethrough. A cooling flow 130 may flow through the internal cooling pathways 110 and exit via the cooling holes 120 so as to cool the airfoil 100. The cooling holes 120 may be positioned along the internal cooling pathway 110 such that the cooling flow 130 is required to make a turn in order to pass therethrough. Other configurations and other components may be used herein.

[0021] The airfoil 100 also includes a pin array 140 within one or more of the internal cooling pathways 110. The pin array 140 may include a number of pin-fins 150. The pin-fins 150 may have any desired size, shape or configuration. Any number of the pin-fins 150 may be used. Other types of flow disrupters such as turbulators and the like also may be used herein.

[0022] In this example, the pin-fins 150 may be positioned in a non-uniform array 160. By the term "non-uniform" array 160, we mean that the distances between the individual pin-fins 150 may vary. Specifically, a turning opening 170 and a guiding opening 180 may be used between individual pin-fins 150. The turning opening 170 simply has a larger open area between the pin-fins 150 as compared to the guide opening 180. Specifically, the turning openings 170 may be about fifteen percent (15%) to about sixty percent (60%) larger than the guiding openings 180, although other ranges may be used herein. The larger open area of the turning openings 170 tends to turn the cooling flow 130 in the desired direction. The pin-fins 150 also may have a variable downstream staggered positioning 190. The variable downstream staggered positioning 190 also aids in directing the cooling flow 130 as desired. In the example shown, the pin array 140 may have a number of columns: a first column 200, a second column 210, a third column 220, and a fourth column 230. Any number of columns may be used herein. The staggered positioning 190 thus extends across the columns.

[0023] The cooling flow 130 thus turns into the turning opening 170 in the first column 200 and continues into the

turning openings 170 of the second column 210, the third column 220, and the fourth column 230. The cooling flow 130 largely takes about a ninety (90) degree turn along the internal cooling pathway 110 into the cooling holes 120. The pin array 140 shown herein is for the purpose of example only. The positioning of the individual pin-fins 150 may vary according to the geometry of the airfoil 100, the internal cooling pathway 110, the cooling holes 120, the pin-fins 150, and the like. The positioning also may vary due to any number of different operational and performance parameters.

[0024] The use of the turning openings 170 so as to turn the cooling flow 130 thus results in a more effective pin array 140 for improved heat transfer and flow control. The cooling flow 130 will have significant momentum component normal thereto. The cooling flow 130 thus is efficiently directed into the cooling holes 120 or other dump region. Specifically, the cooling flow 130 stagnates alternatively on different pin rows so as to provide this direction. Moreover, the pin-fins 150 are positioned so as to optimize local flow velocity. Improved heat transfer may result in lower flow requirements and enhance increased overall efficiency. The pin array 140 also has larger pin spacings so as to reduce manufacturing costs and complexity while still providing effective heat transfer and flow control.

[0025] It should be apparent that the foregoing relates only to certain embodiments of the present application and the resultant patent. Numerous changes and modifications may be made herein by one of ordinary skill in the art without departing from the general spirit and scope of the invention as defined by the following claims and the equivalents thereof.

I claim:

1. An airfoil with a cooling flow therein, comprising:
 - an internal cooling passage;
 - a plurality of cooling holes in communication with the internal cooling passage; and
 - a plurality of pin-fins positioned within the internal cooling passage;
 - the plurality of pin-fins comprising one or more turning openings and one or more guiding openings so as to direct the cooling flow towards the plurality of cooling holes.
2. The airfoil of claim 1, wherein the plurality of pin-fins comprises a non-uniform array.
3. The airfoil of claim 1, further comprising a plurality of internal cooling passages.
4. The airfoil of claim 1, wherein the plurality of pin-fins comprises a staggered positioning across a pair of columns.
5. The airfoil of claim 4, wherein the plurality of pin-fins comprises a staggered positioning across a plurality of columns.
6. The airfoil of claim 1, wherein the one or more turning openings comprise a first distance between a first pair of the plurality of pin-fins, the one or more guiding openings comprise a second distance between a second pair of the plurality of pin-fins, and wherein the first distance is greater than the second distance.
7. The airfoil of claim 1, wherein the one or more turning openings turn the cooling flow about ninety (90) degrees.
8. The airfoil of claim 1, wherein the plurality of cooling holes comprises a plurality of trailing edge cooling holes.
9. The airfoil of claim 1, further comprising a plurality of turning openings over a plurality of columns.
10. The air foil of claim 1, further comprising a plurality of guiding openings over a plurality of columns.

- 11.** An airfoil with a cooling flow therein, comprising:
an internal cooling passage;
a plurality of cooling holes in communication with the internal cooling passage; and
a plurality of pin-fins positioned within the internal cooling passage in a non-uniform array;
the plurality of pin-fins comprising one or more turning openings and one or more guiding openings in a staggered positioning so as to direct the cooling flow towards the plurality of cooling holes.
- 12.** The airfoil of claim **11**, wherein the one or more turning openings comprise a first distance between a first pair of the plurality of pin-fins, the one or more guiding openings comprise a second distance between a second pair of the plurality of pin-fins, and wherein the first distance is greater than the second distance.
- 13.** The airfoil of claim **11**, wherein the one or more turning openings turn the cooling flow about ninety (90) degrees.
- 14.** The airfoil of claim **11**, wherein the plurality of cooling holes comprises a plurality of trailing edge cooling holes.
- 15.** The airfoil of claim **11**, further comprising a plurality of turning openings over a plurality of columns.
- 16.** The air foil of claim **11**, further comprising a plurality of guiding openings over a plurality of columns.
- 17.** An internal cooling passage with a cooling flow therein, comprising:
a plurality of cooling holes; and
a plurality of pin-fins positioned within the internal cooling passage;
the plurality of pin-fins comprising one or more turning openings with a first distance between a first pair of the plurality of pin-fins, one or more guiding openings with a second distance between a second pair of the plurality of pin-fins, and wherein the first distance is greater than the second distance.
- 18.** The internal cooling passage of claim **17**, wherein the plurality of pin-fins comprises a non-uniform array.
- 19.** The internal cooling passage of claim **17**, wherein the one or more turning openings turn the cooling flow about ninety (90) degrees.
- 20.** The internal cooling passage of claim **17**, further comprising a plurality of turning openings over a plurality of columns.

* * * * *