



(19) **United States**

(12) **Patent Application Publication**
SHIPCHANDLER et al.

(10) **Pub. No.: US 2012/0298522 A1**

(43) **Pub. Date: Nov. 29, 2012**

(54) **SYSTEMS AND METHODS FOR SODA ASH PRODUCTION**

Publication Classification

(76) Inventors: **RIYAZ SHIPCHANDLER**,
Campbell, CA (US); **Betty Kong**
Ling Pun, San Jose, CA (US);
Michael Joseph Weiss, Los Gatos,
CA (US)

(51) **Int. Cl.**
C25B 1/14 (2006.01)
C25B 15/00 (2006.01)
C25B 9/00 (2006.01)

(52) **U.S. Cl.** **205/482; 204/275.1**

(21) Appl. No.: **13/347,514**

(57) **ABSTRACT**

(22) Filed: **Jan. 10, 2012**

Provided herein are methods and systems to produce sodium carbonate (soda ash). The methods and systems provided herein modify a Solvay process by integrating it with an electrochemical process to produce a less carbon dioxide intensive Solvay process and an environmentally friendly sodium carbonate product.

Related U.S. Application Data

(60) Provisional application No. 61/431,767, filed on Jan. 11, 2011, provisional application No. 61/446,482, filed on Feb. 24, 2011.

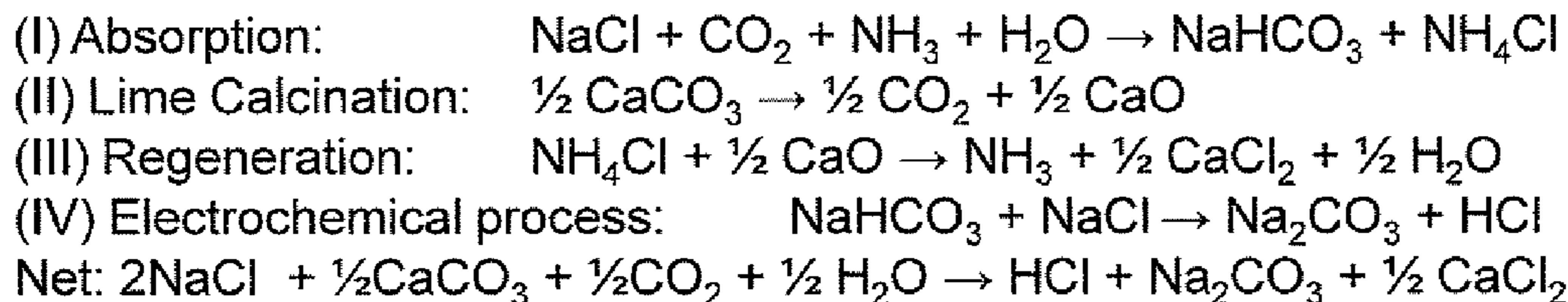
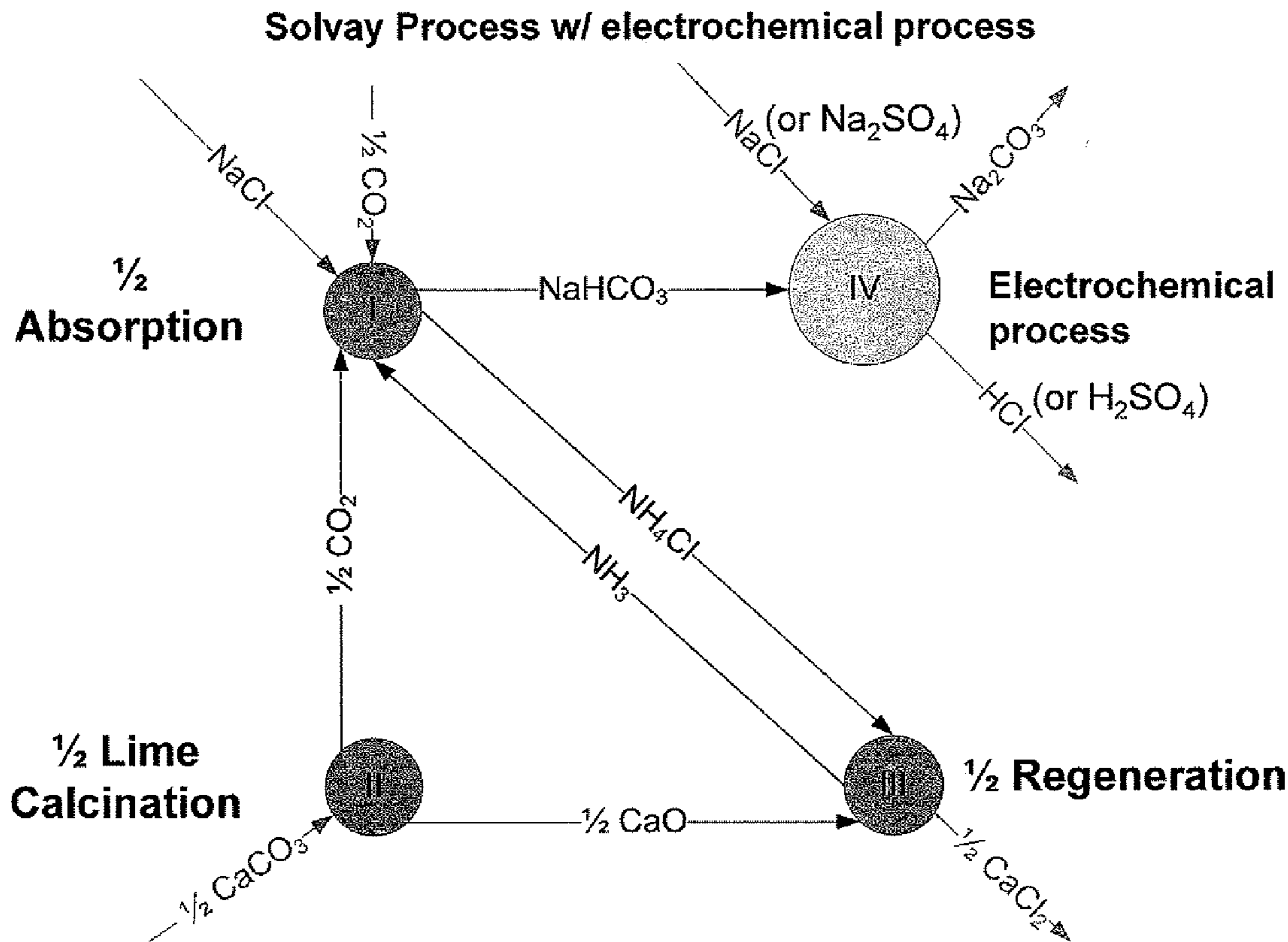

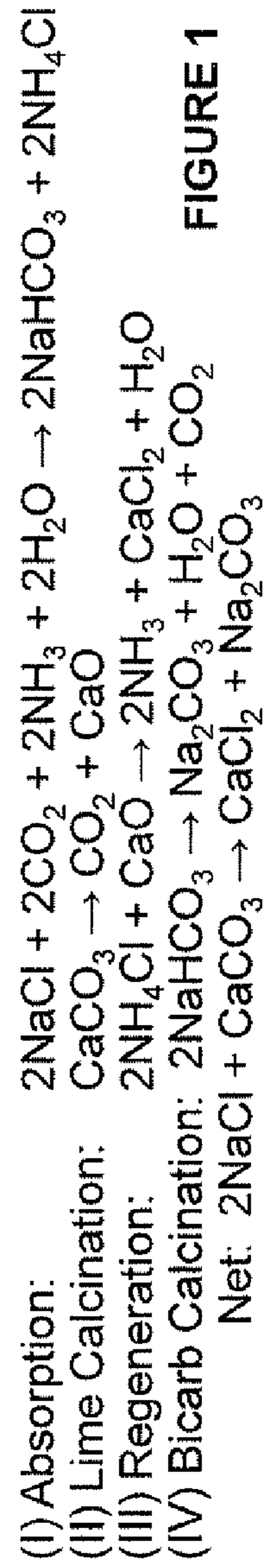
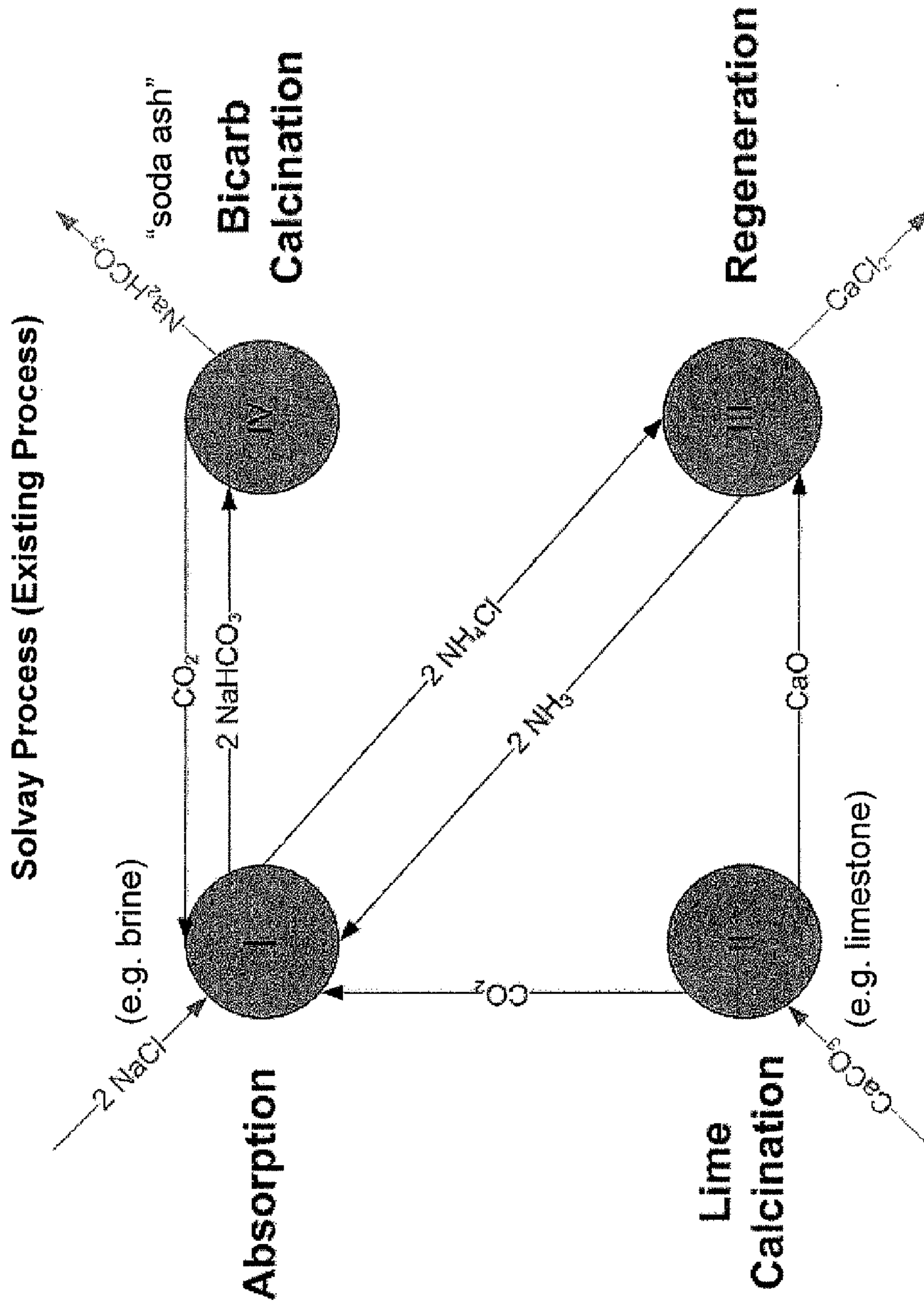
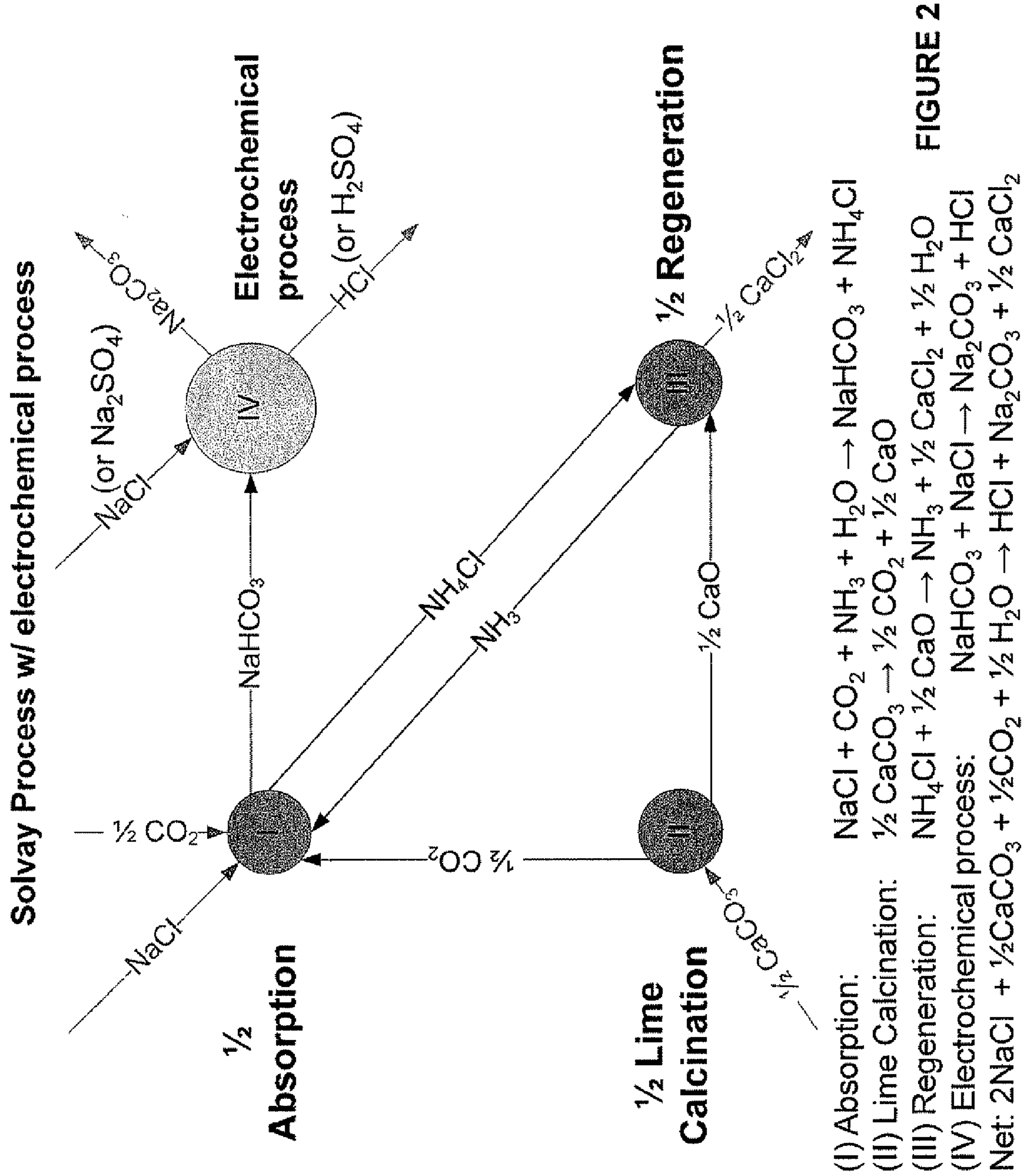

FIGURE 1



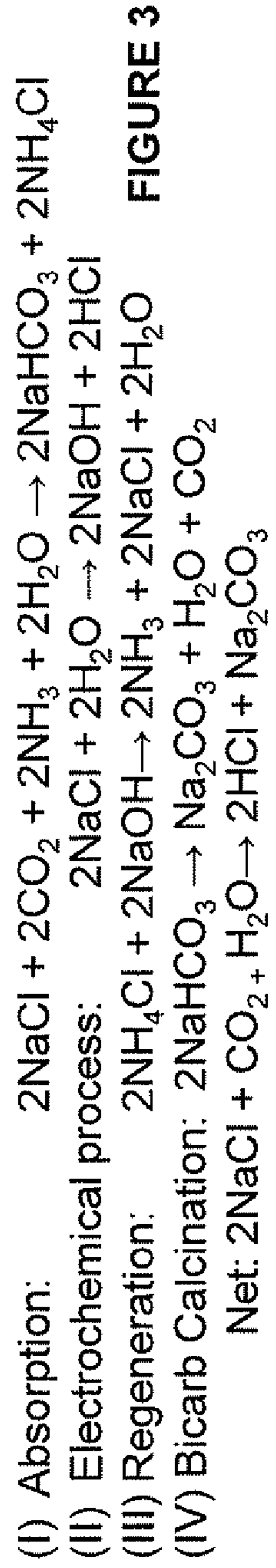
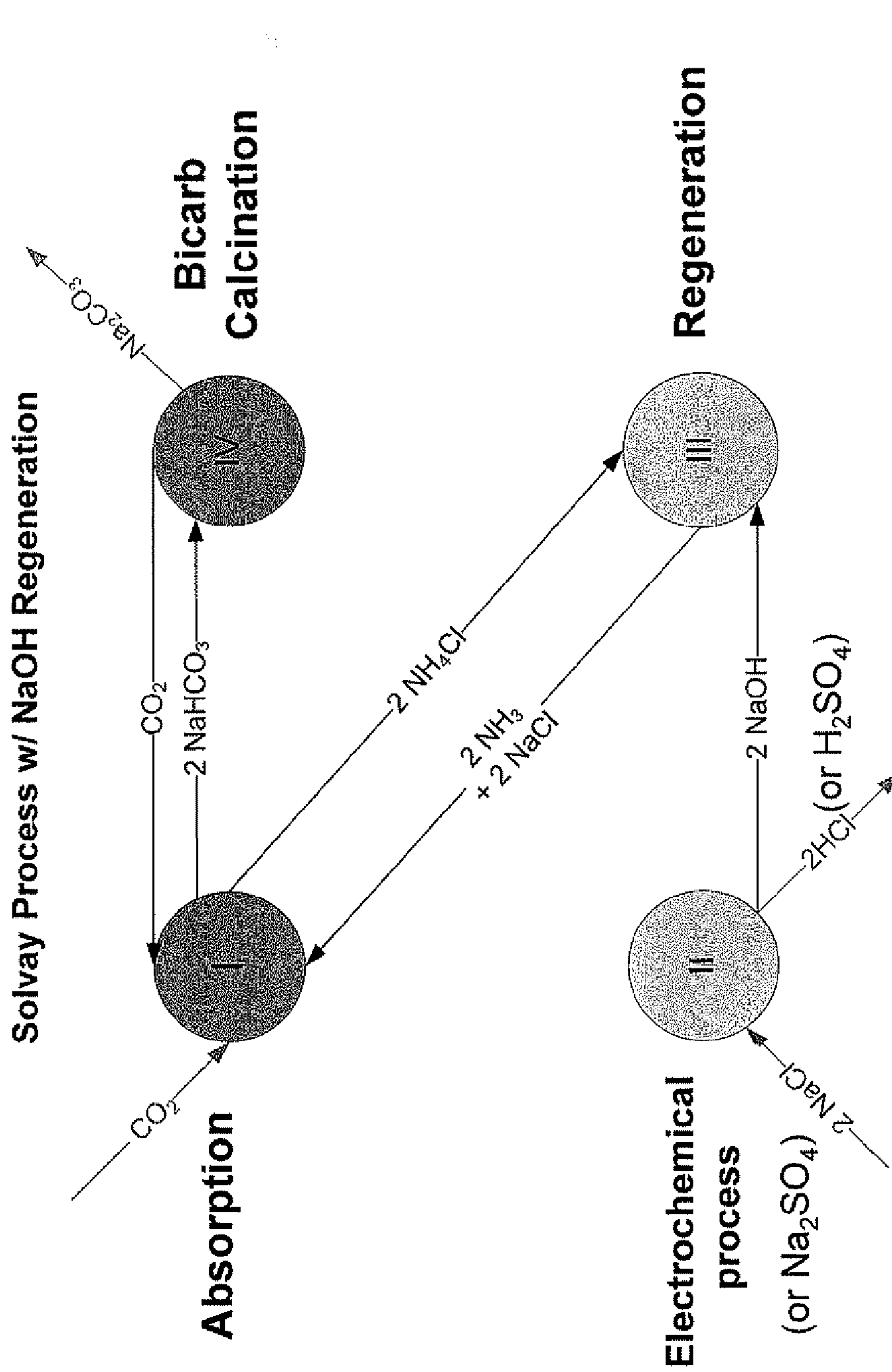
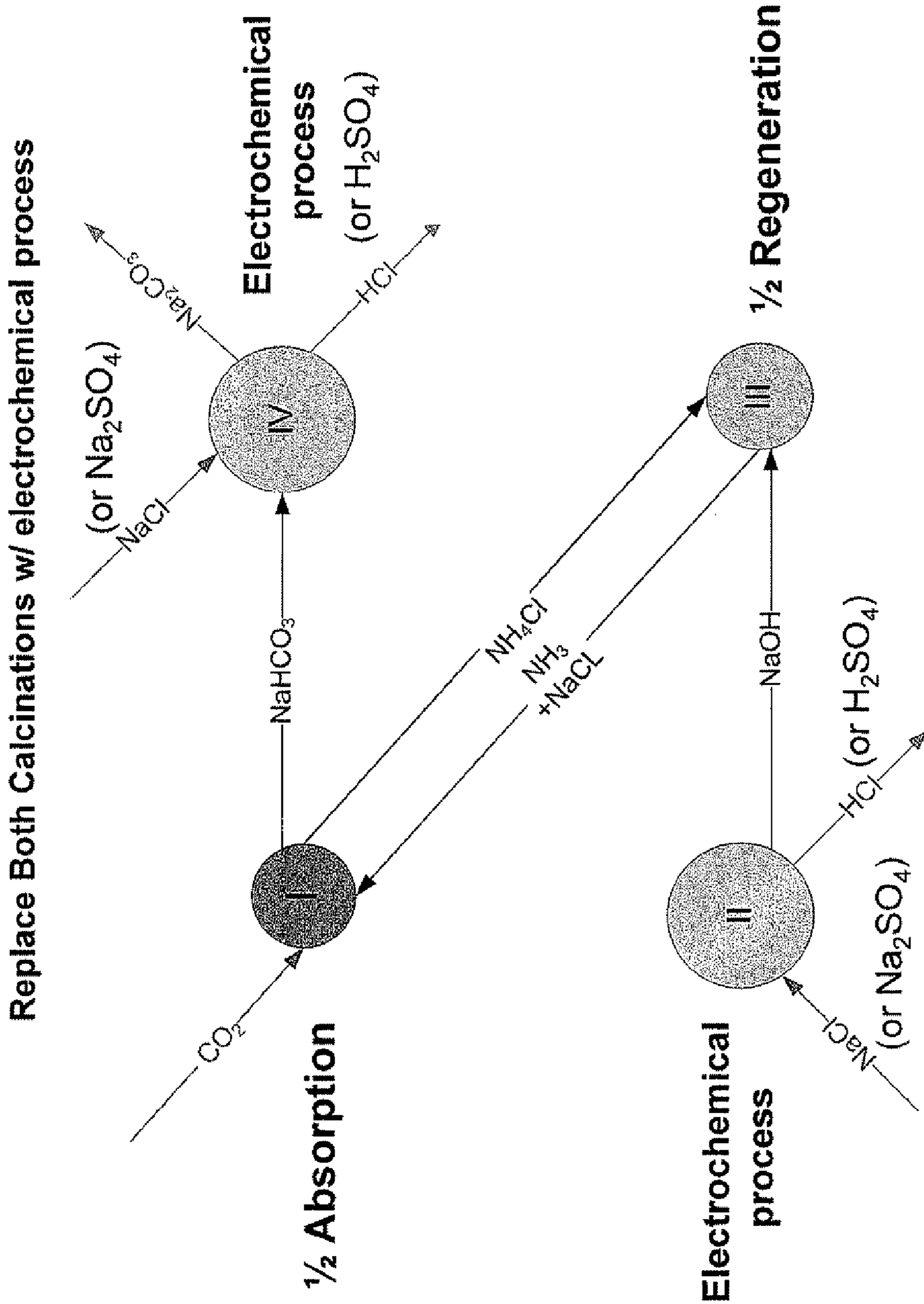

FIGURE 3



(I) Absorption: $\text{NaCl} + \text{CO}_2 + \text{NH}_3 + \text{H}_2\text{O} \rightarrow \text{NaHCO}_3 + \text{NH}_4\text{Cl}$
 (II) Electrochemical process: $\text{NaCl} + \text{H}_2\text{O} \rightarrow \text{NaOH} + \text{HCl}$
 (III) Regeneration: $\text{NH}_4\text{Cl} + \text{NaOH} \rightarrow \text{NH}_3 + \text{NaCl} + \text{H}_2\text{O}$
 (IV) Electrochemical process: $\text{NaHCO}_3 + \text{NaCl} \rightarrow \text{Na}_2\text{CO}_3 + \text{HCl}$
 Net: $2 \text{NaCl} + \text{CO}_2 + \text{H}_2\text{O} \rightarrow \text{Na}_2\text{CO}_3 + 2\text{HCl}$

FIGURE 4

Direct Capture w/ electrochemical process and absorber

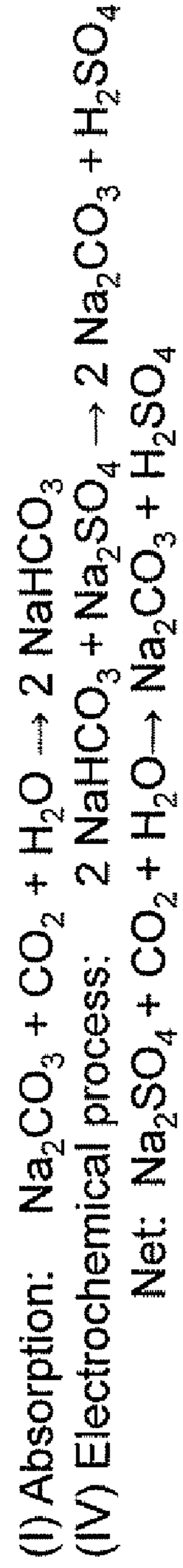
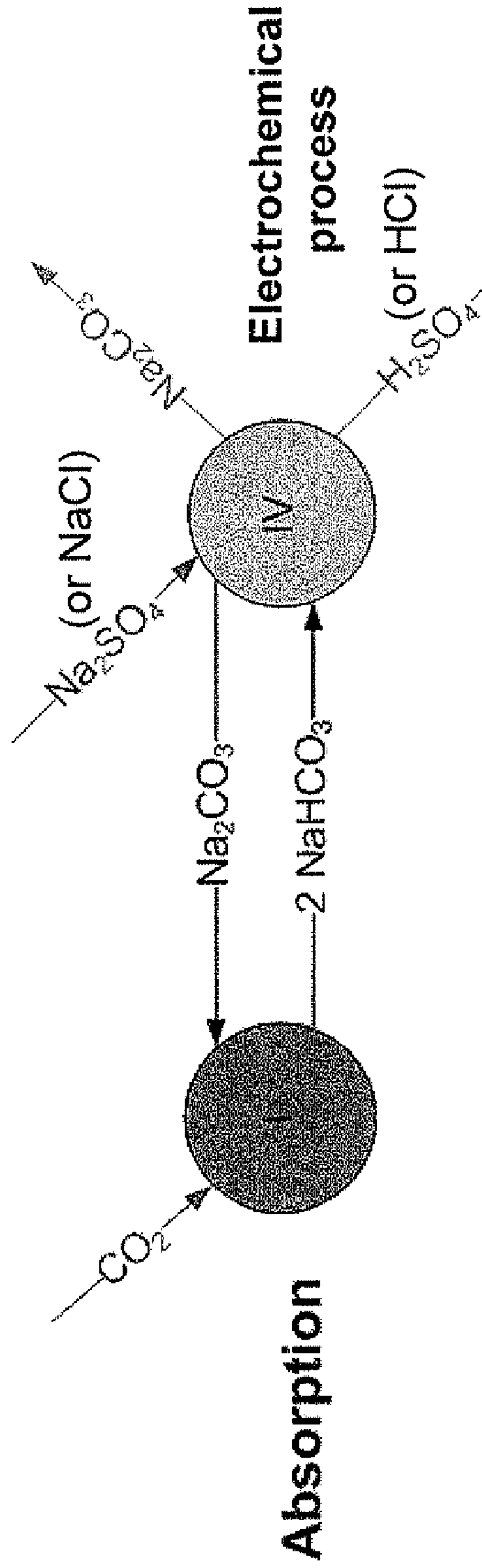

FIGURE 5

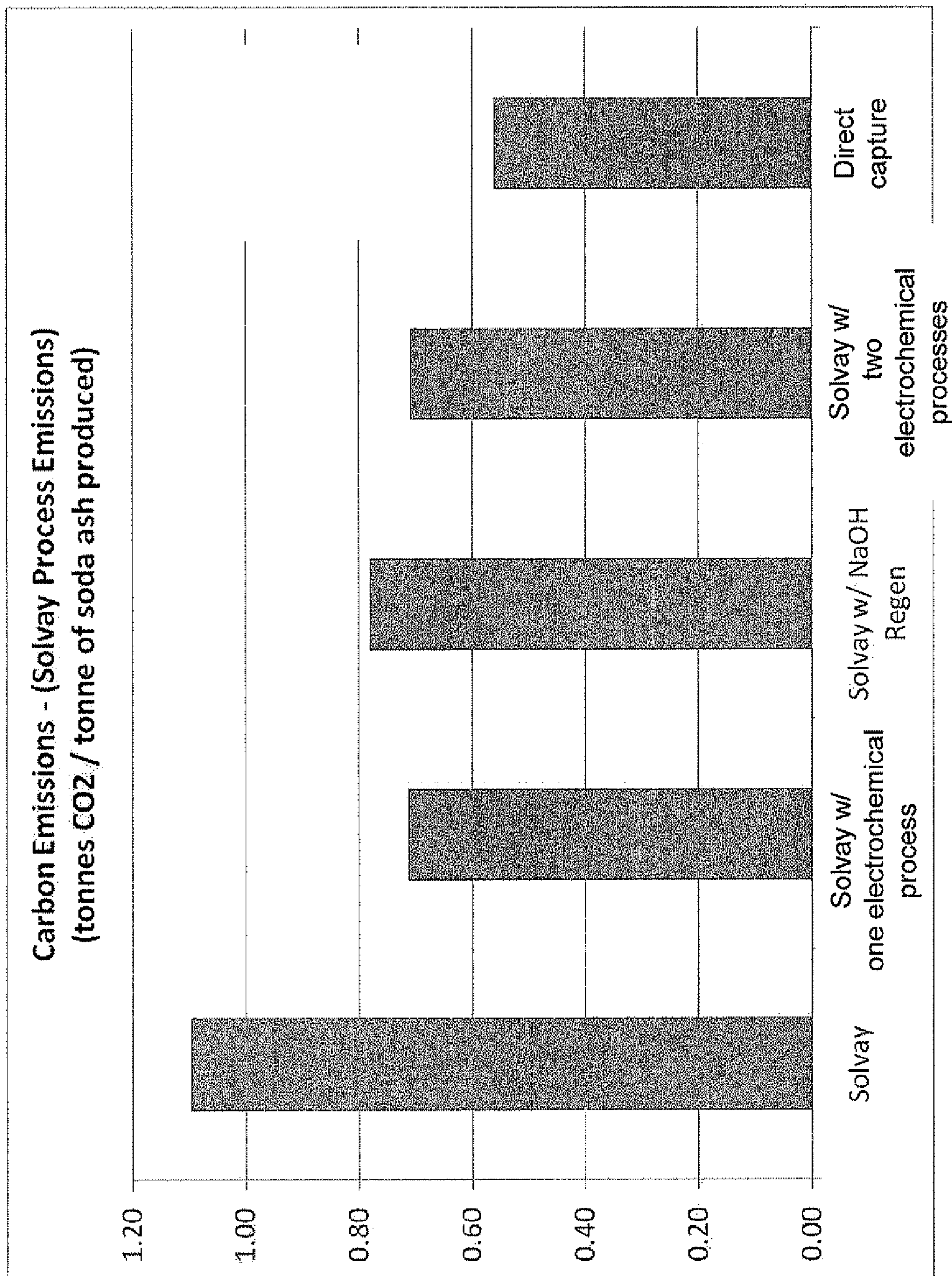

FIGURE 6

**Alkaline Brines (Searles Valley minerals, SVM)
Existing Process**

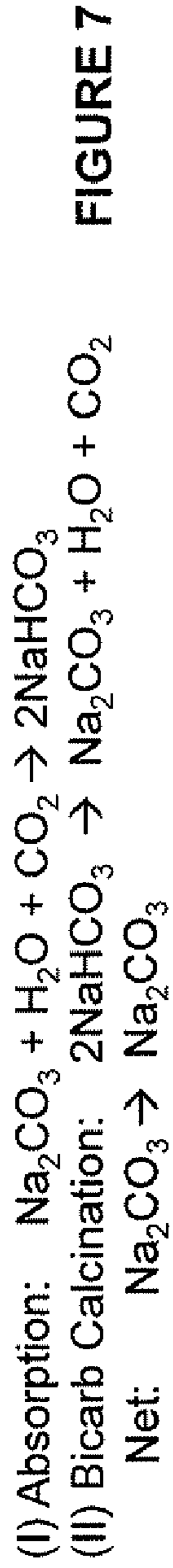
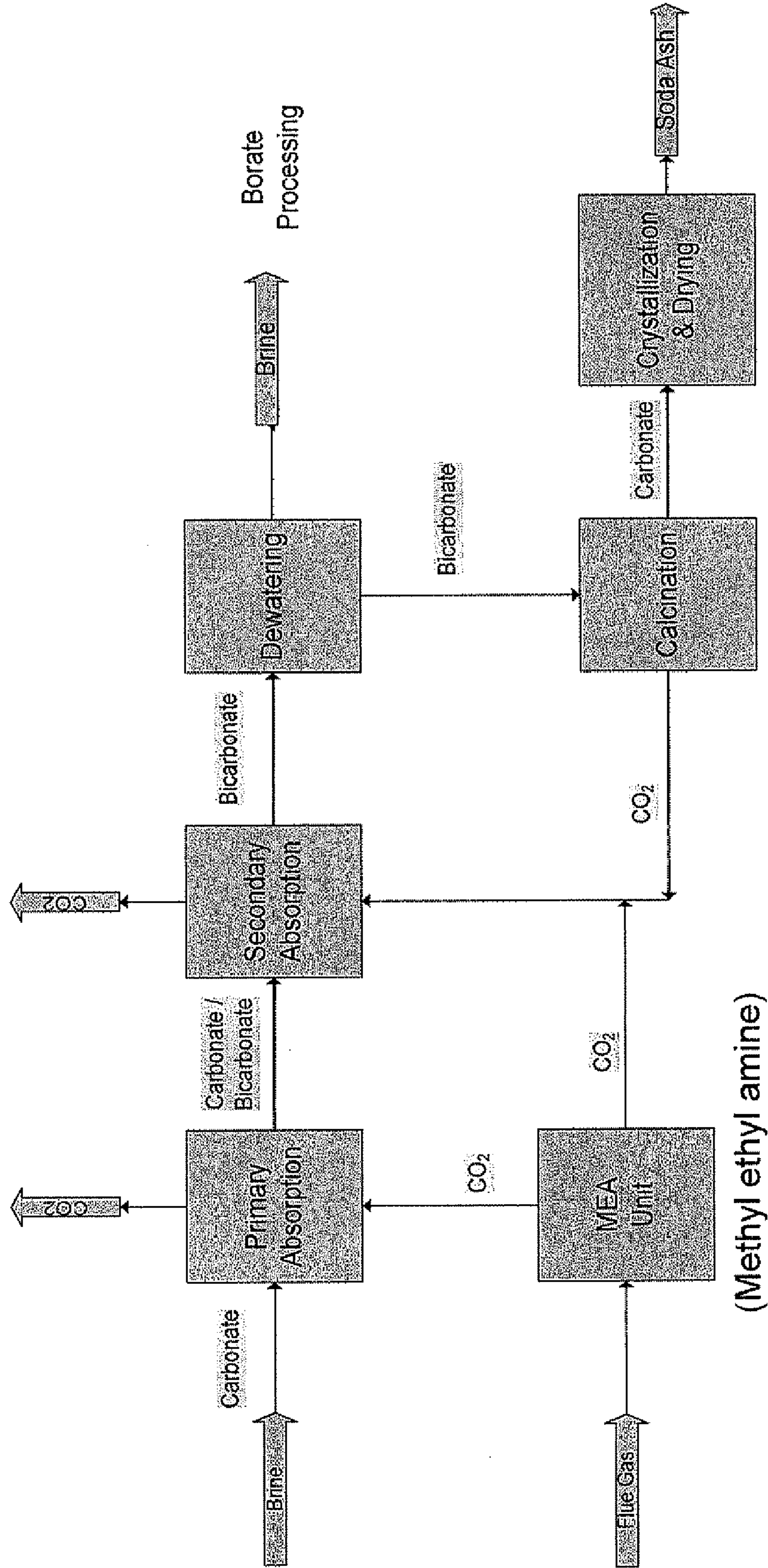

FIGURE 7

Alkaline Brines w/ Electrochemical process

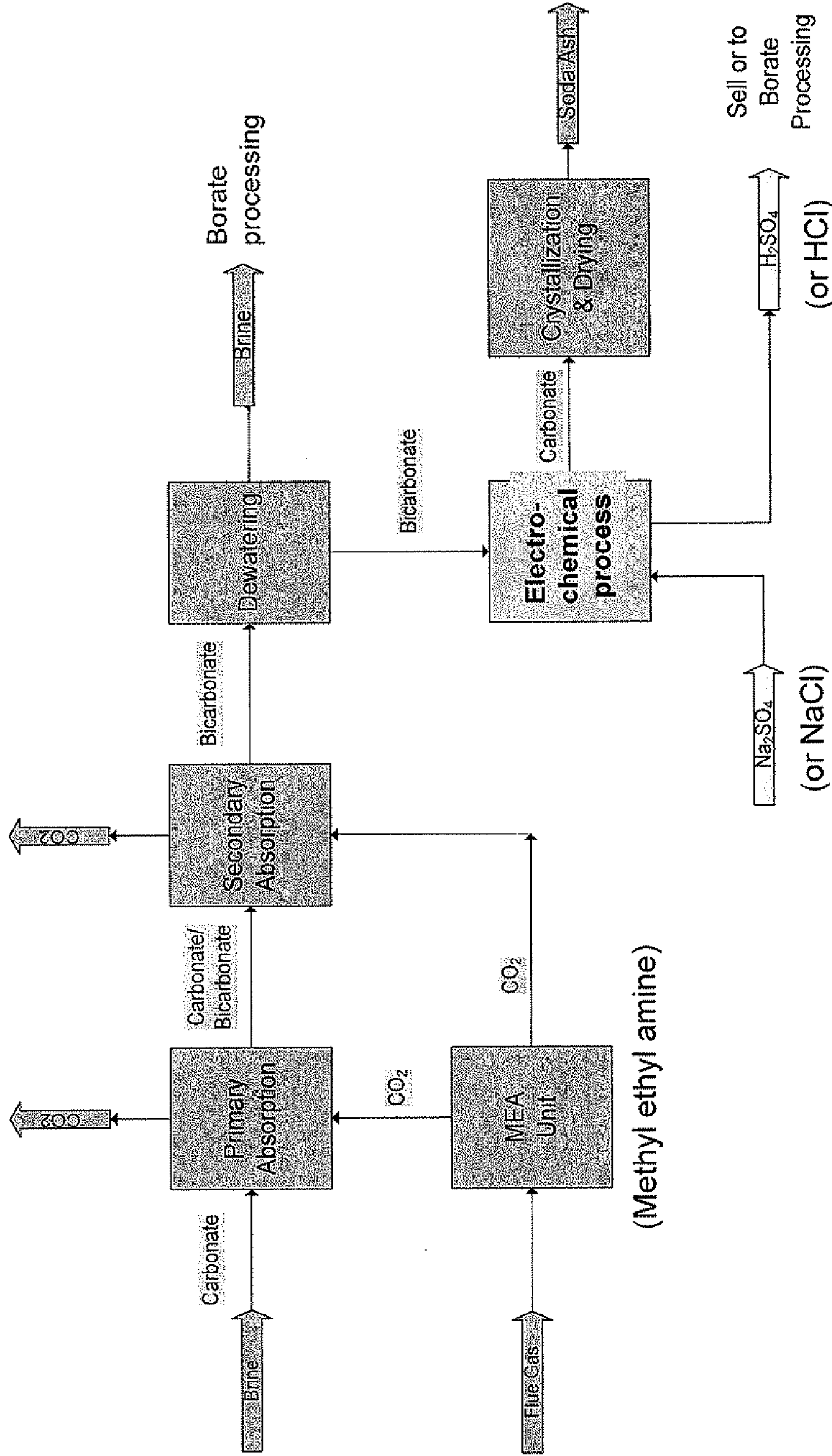
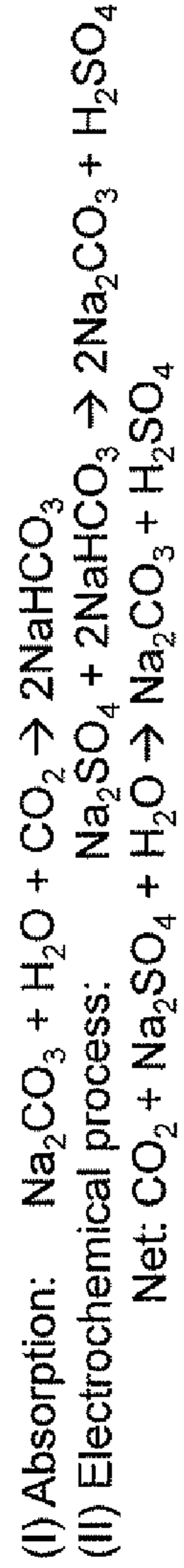

FIGURE 8



Alkaline Brines w/ Acid Recycle

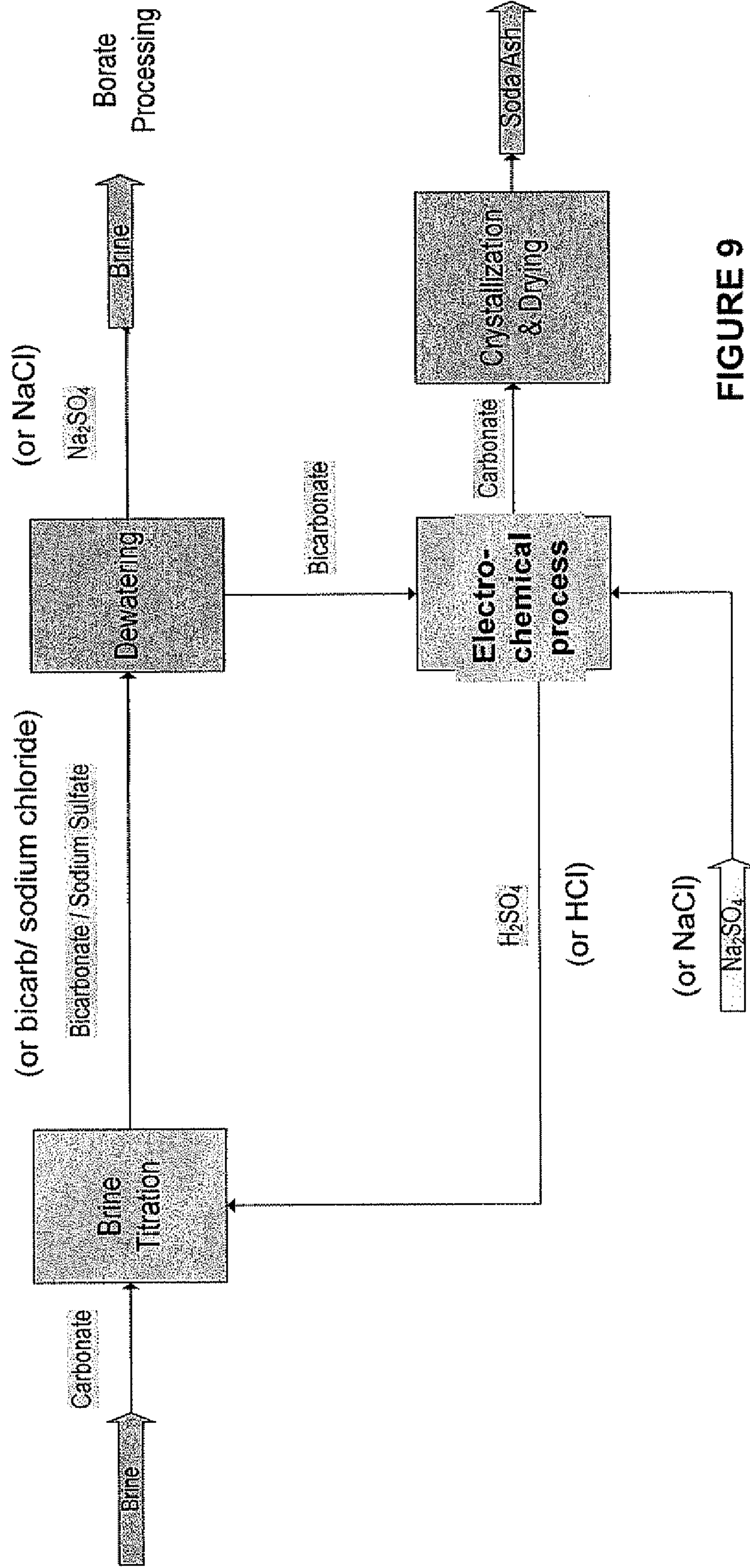
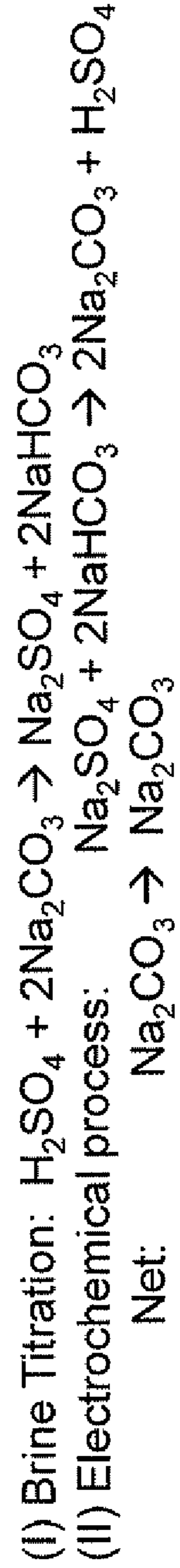

FIGURE 9



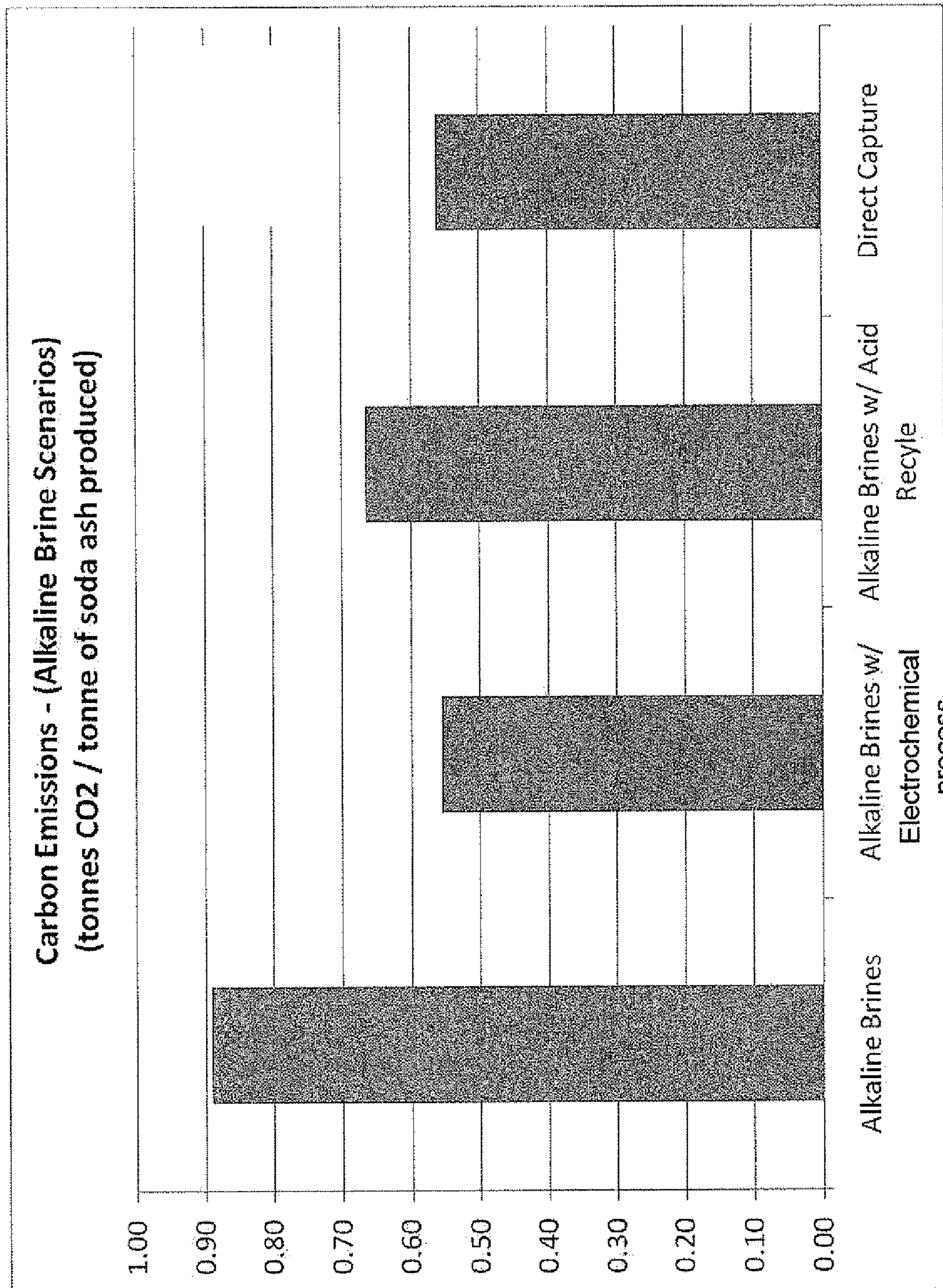

FIGURE 10

Trona Ore Process (Existing)

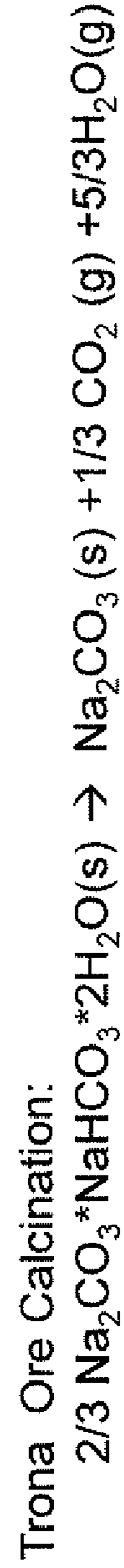
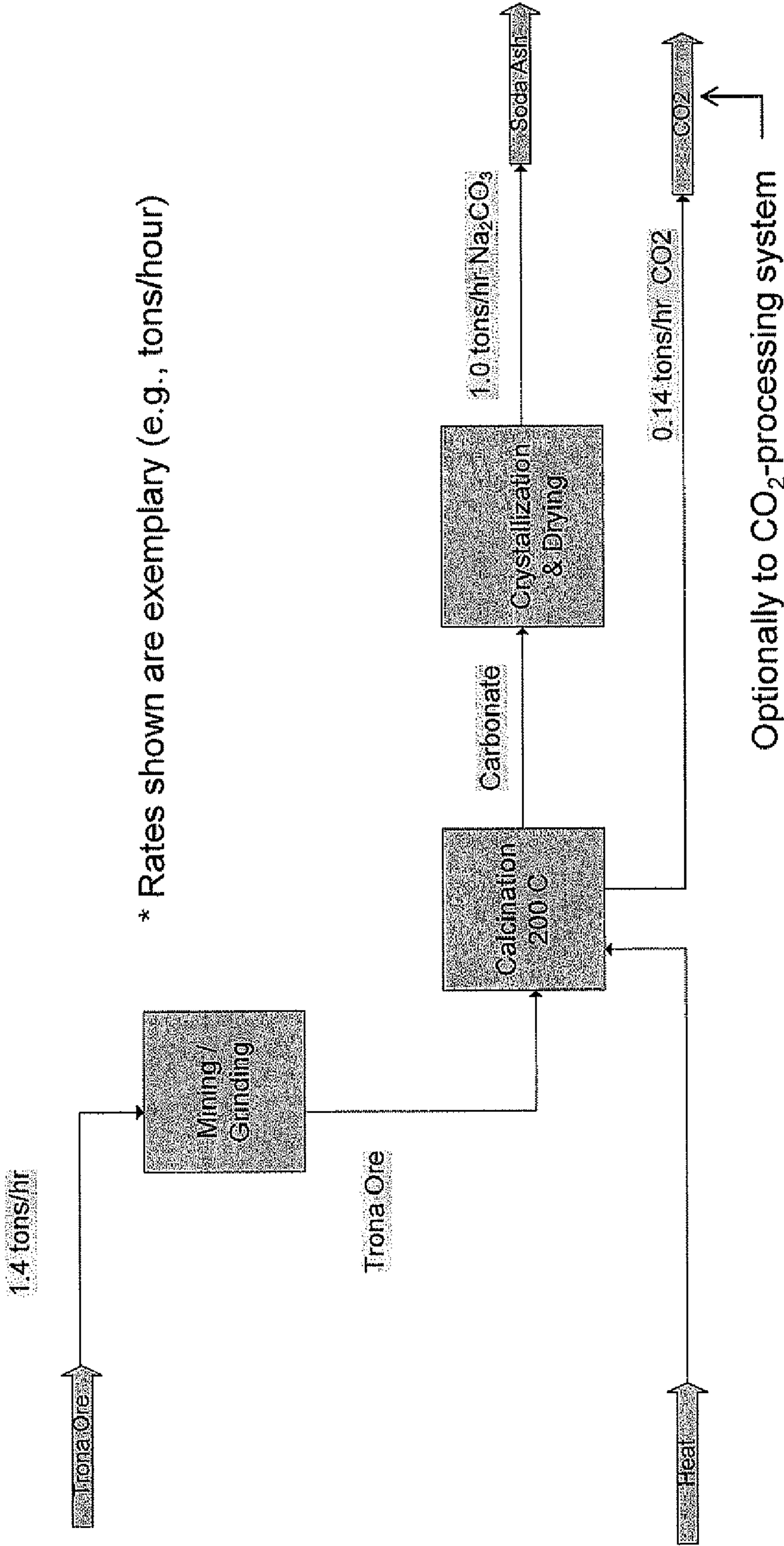
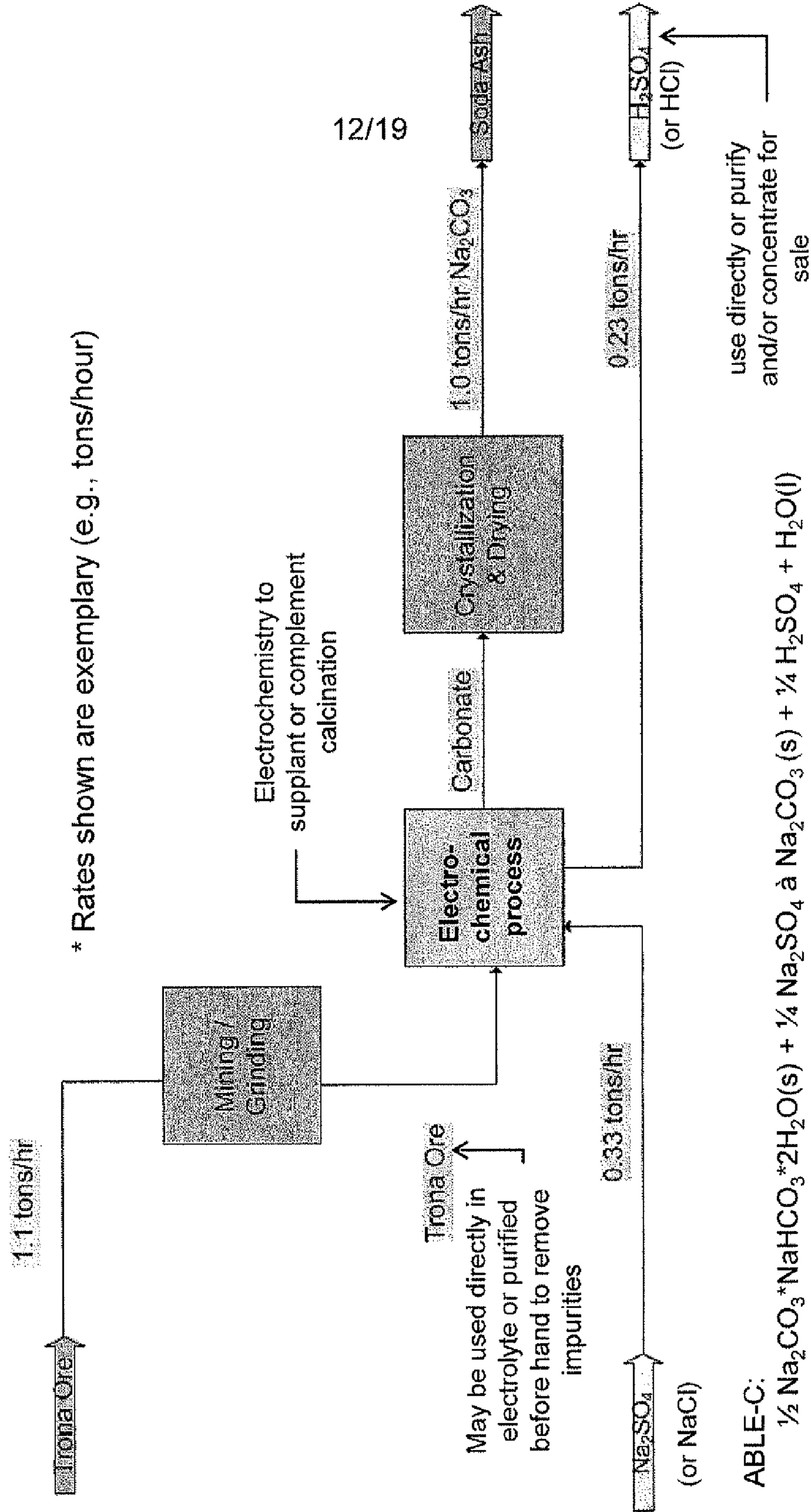

FIGURE 11

Optionally to CO₂-processing system

Trona Ore Process w/ Electrochemical process



12/19

FIGURE 12

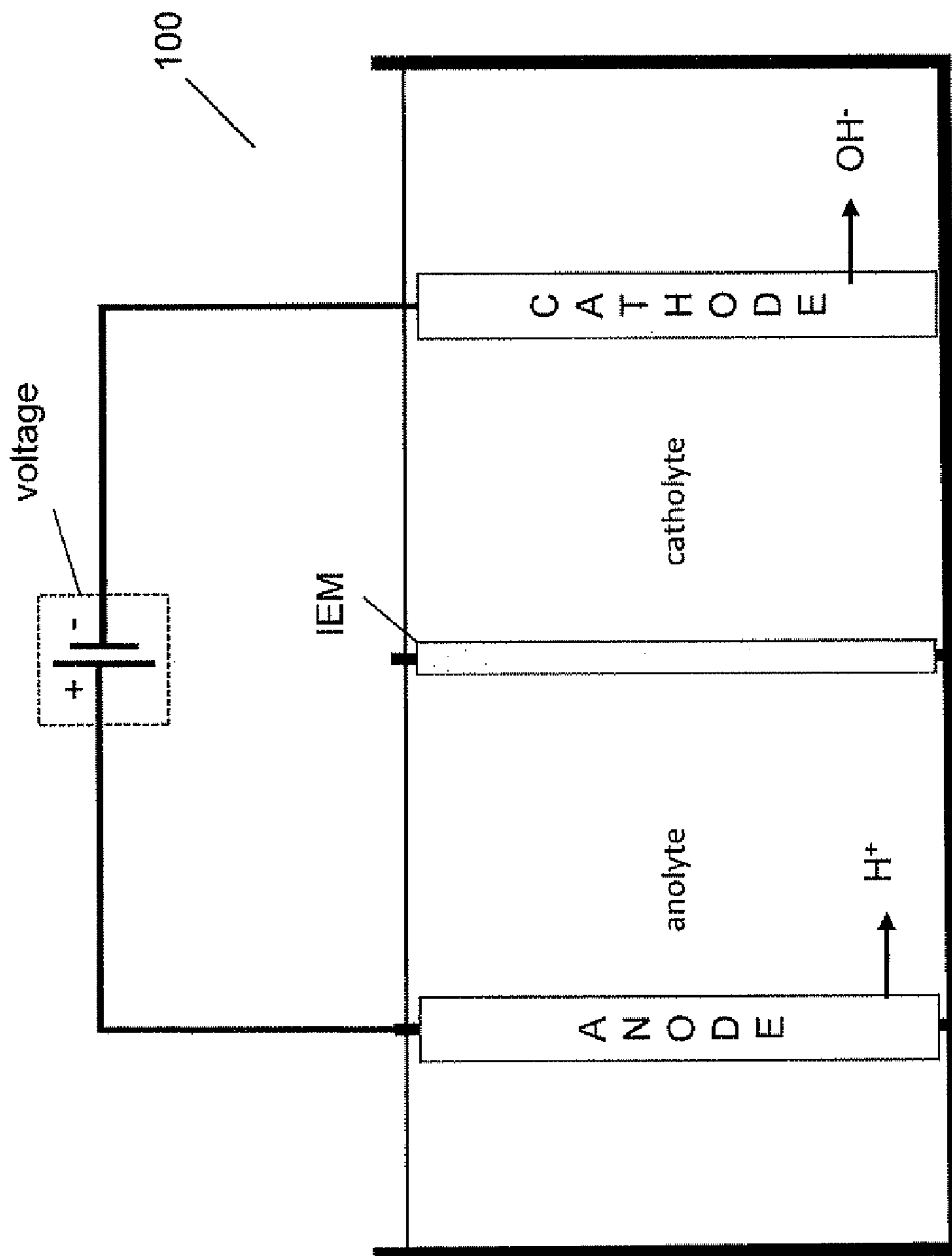

FIGURE 13

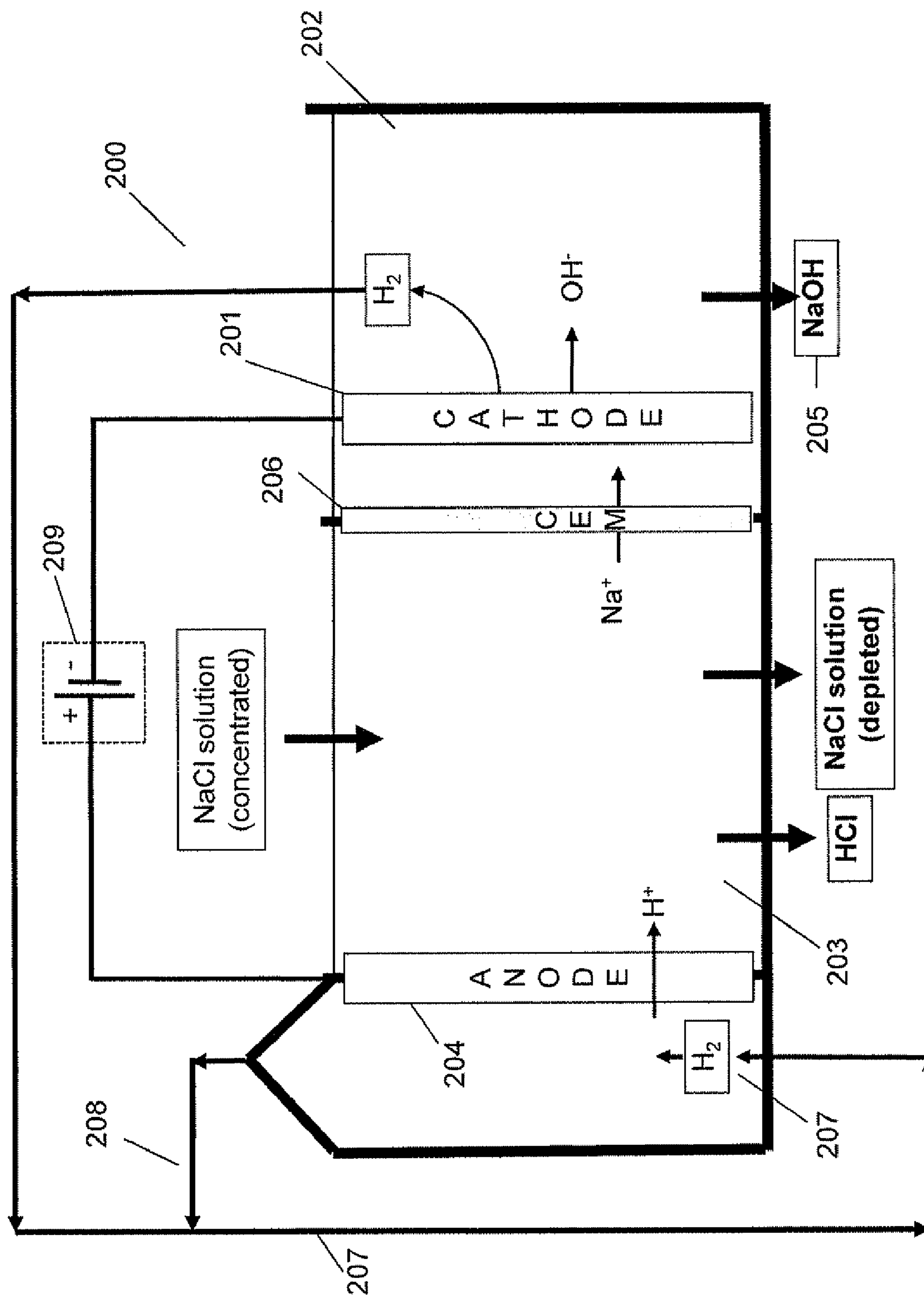

FIGURE 14

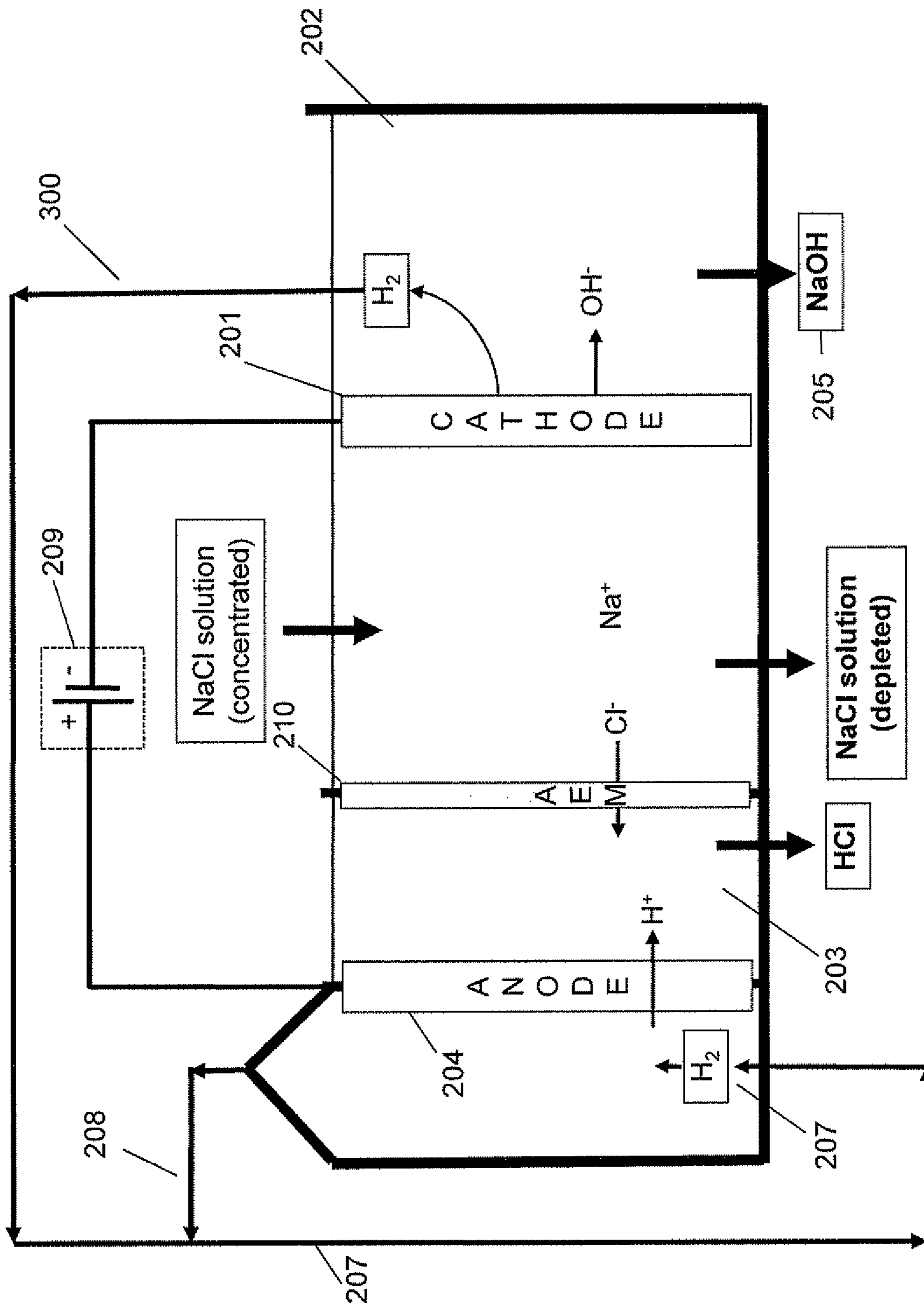

FIGURE 15

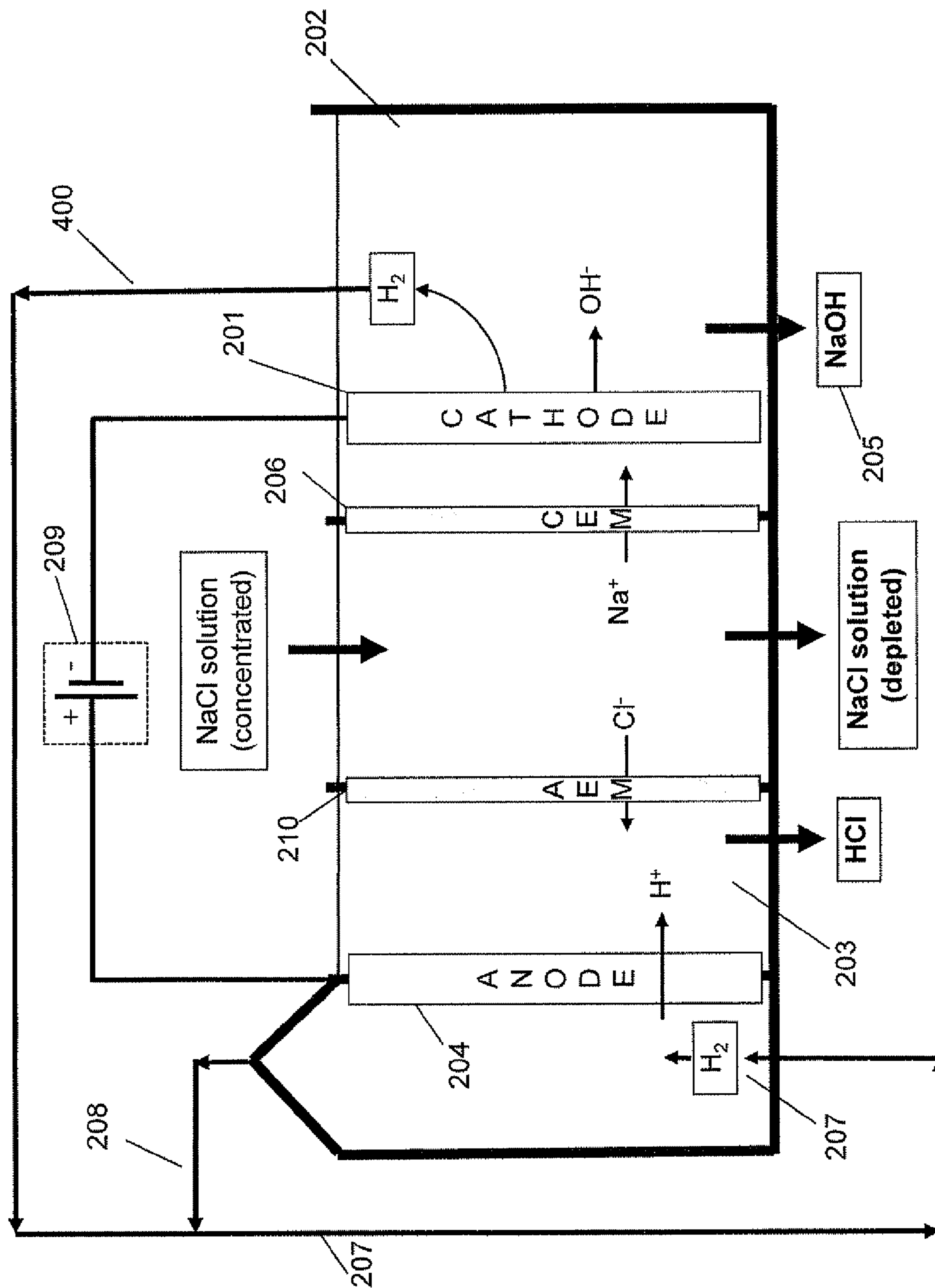

FIGURE 16

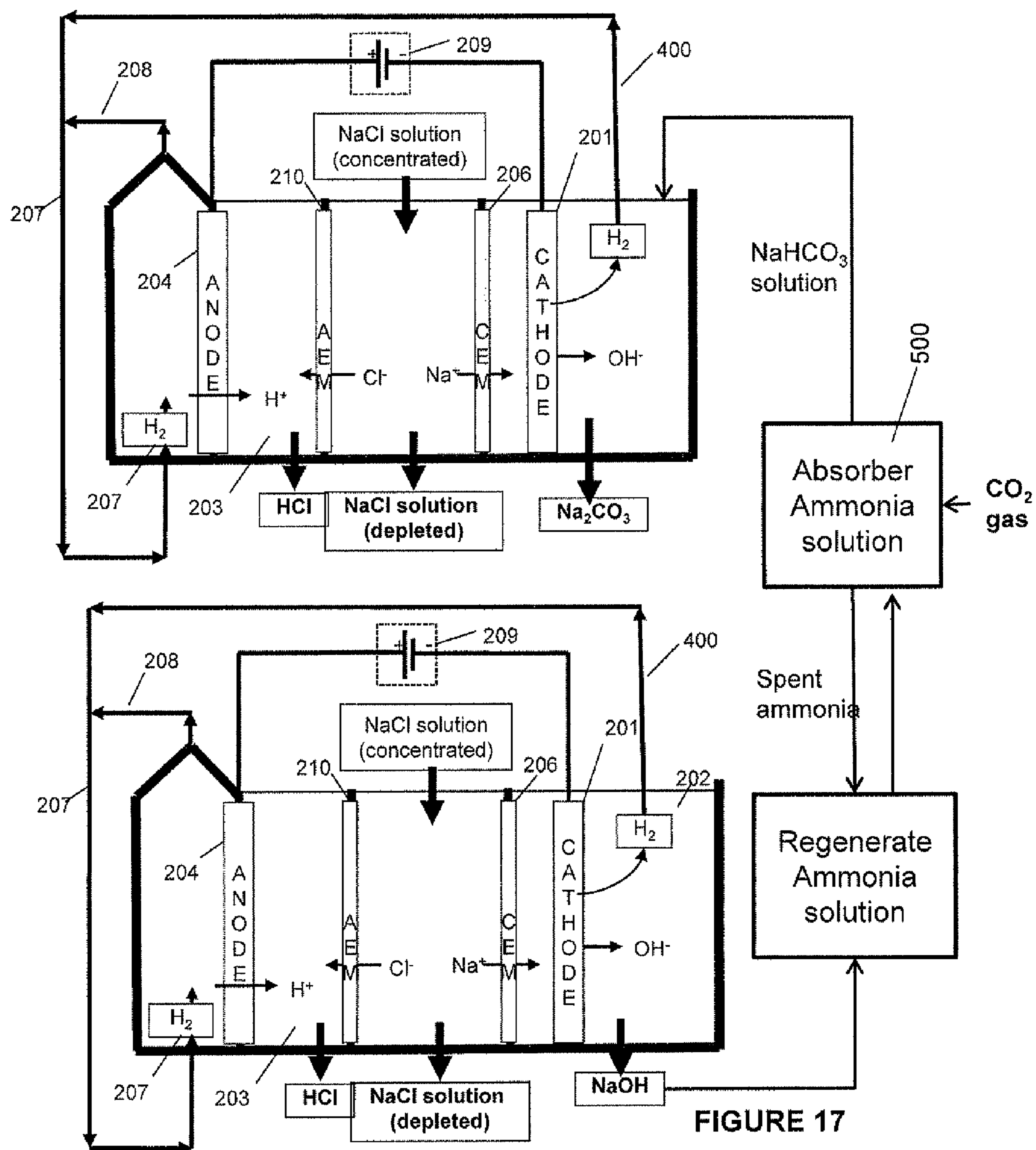

FIGURE 17

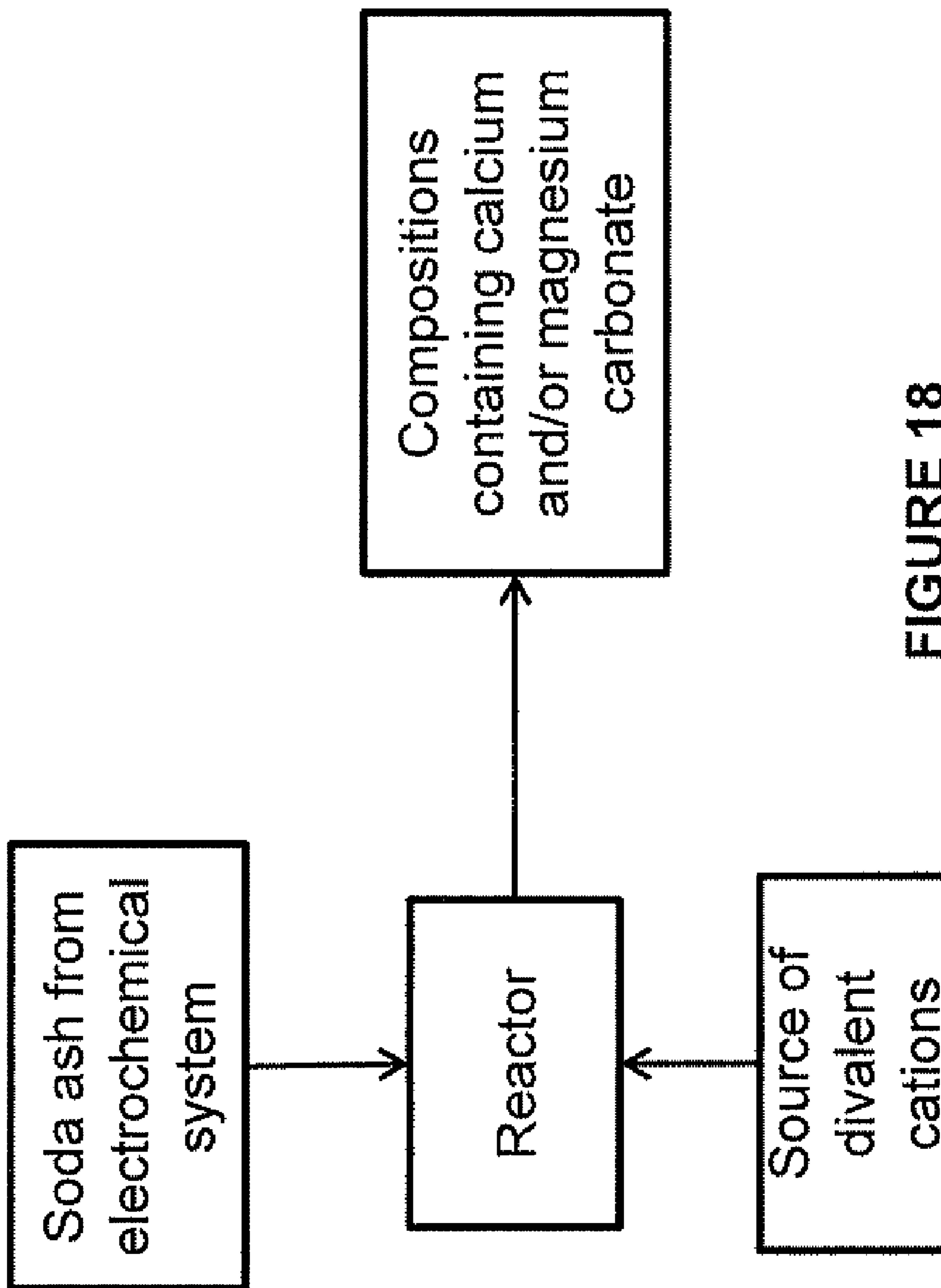

FIGURE 18

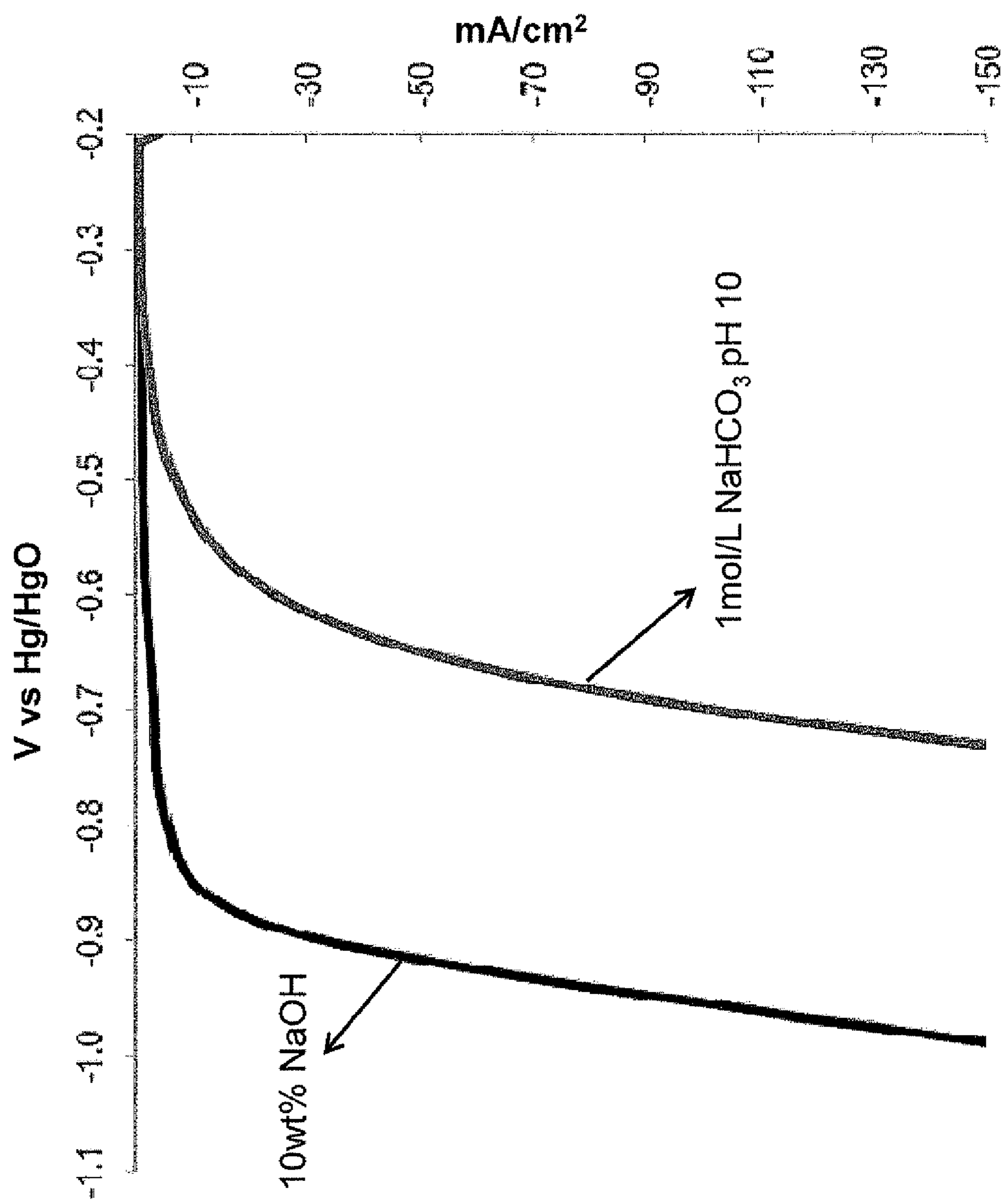

FIGURE 19

SYSTEMS AND METHODS FOR SODA ASH PRODUCTION

CROSS-REFERENCE

[0001] This application claims priority to U.S. Provisional Application No. 61/431,767, filed Jan. 11, 2011 and U.S. Provisional Application No. 61/446,482, filed Feb. 24, 2011, both of which are incorporated herein by reference in their entireties. This application is related to the following patent applications: U.S. Provisional Patent Application No. 61/081,299, filed 16 Jul. 2008, titled "Low Energy pH Modulation for Carbon Sequestration Using Hydrogen Absorptive Metal Catalysts"; U.S. Provisional Patent Application No. 61/091,729, filed 25 Aug. 2008, titled "Low Energy Absorption of Hydrogen Ion from an Electrolyte Solution into a Solid Material"; U.S. Provisional Patent Application No. 61/222,456, filed 1 Jul. 2009, titled "CO₂ Utilization In Electrochemical Systems"; and PCT Patent Application No. PCT/US09/48511, filed on 25 Jun. 2009, titled "Low Energy 4-Cell Electrochemical System with Carbon Dioxide Gas," each of which is incorporated herein by references in its entirety.

BACKGROUND

[0002] The Solvay process, also referred to as the ammonia-soda process, is an industrial process for production of soda ash (sodium carbonate). The ingredients for this process may be readily available: salt brine (from inland sources or from the sea) and limestone (from mines). Carbon dioxide is emitted from the use of soda ash, and is emitted during production of soda ash, depending on the industrial process used to manufacture soda ash. There is a need for systems and methods for production of soda ash in a less carbon dioxide-intensive manner.

SUMMARY

[0003] Provided herein is a novel and non-obvious process, machine, manufacture, and composition thereof.

[0004] In one aspect, there is provided a method to produce sodium carbonate, comprising: a) absorbing carbon dioxide in an ammonia solution to form sodium bicarbonate; and b) subjecting the sodium bicarbonate to a first electrochemical process to produce sodium carbonate. In one aspect, there is provided a method to modify a Solvay process to produce a less carbon dioxide intensive Solvay process, comprising: a) absorbing carbon dioxide in an ammonia solution to form sodium bicarbonate; and b) subjecting the sodium bicarbonate to a first electrochemical process to produce sodium carbonate, thereby resulting in a less carbon dioxide intensive Solvay process. In some embodiments of these aspects, the method further comprises regenerating the ammonia solution using calcium oxide obtained by lime calcination. In some embodiments of these aspects, the method further comprises regenerating the ammonia solution using sodium hydroxide obtained from the first or a second electrochemical process. In some embodiments of these aspects, the method does not comprise bicarbonate calcination, lime calcination, or a combination thereof. In some embodiments of these aspects, the method produces less than 80% carbon dioxide as compared to a conventional Solvay process. In some embodiments of these aspects, the method further comprises treating the sodium carbonate with calcium or magnesium ions to form calcium carbonate, magnesium carbonate, or combination thereof. In some embodiments, the calcium carbonate, mag-

nesium carbonate, or combination thereof is a cementitious material. In some embodiments, the cementitious material comprises vaterite. In some embodiments, the cementitious material has a compressive strength of greater than 10 MPa.

[0005] In one aspect, there is provided a system comprising a Solvay system integrated with an electrochemical system, comprising: a) a Solvay system comprising an absorber configured to absorb carbon dioxide in an ammonia solution to form sodium bicarbonate; and b) a first electrochemical system operably connected to the Solvay system configured to convert the sodium bicarbonate to sodium carbonate. In some embodiments of the systems, the system further comprises a regenerator operably connected to the Solvay system configured to regenerate the ammonia solution after absorption of the carbon dioxide in the ammonia solution. In some embodiments of the systems, the system further comprises a lime calciner operably connected to the regenerator and configured to produce calcium oxide for regenerating the ammonia solution. In some embodiments of the systems, the system further comprises a second electrochemical system operably connected to the regenerator and configured to produce sodium hydroxide for regenerating the ammonia solution. In some embodiments of the systems, the system further comprises a precipitator operably connected to the first electrochemical system configured to produce calcium and/or magnesium carbonate by treating sodium carbonate with calcium and/or magnesium ions.

DRAWINGS

[0006] The novel features of the invention are set forth with particularity in the appended claims. A better understanding of the features and advantages of the invention will be obtained by reference to the following detailed description that sets forth illustrative embodiments, in which the principles of the invention are utilized, and the accompanying drawings of which:

[0007] FIG. 1 provides the Solvay process for preparing soda ash.

[0008] FIG. 2 is an illustrative embodiment of a modification of the Solvay process incorporating electrochemical process.

[0009] FIG. 3 is an illustrative embodiment of another modification of the Solvay process incorporating electrochemical process.

[0010] FIG. 4 is an illustrative embodiment of yet another modification of the Solvay process incorporating two electrochemical processes.

[0011] FIG. 5 is an illustrative embodiment of a process for producing soda ash from direct capture of carbon dioxide.

[0012] FIG. 6 is an illustrative embodiment of a comparison of carbon dioxide emissions from the processes illustrated in FIGS. 1-5.

[0013] FIG. 7 is an illustrative embodiment of a process for producing soda ash from alkaline brines in accordance with the existing process by Searles Valley Minerals (Overland Park, Kans.).

[0014] FIG. 8 is an illustrative embodiment of a modification of the Searles Valley Minerals process incorporating electrochemical process.

[0015] FIG. 9 is an illustrative embodiment of a process for producing soda ash from alkaline brines incorporating electrochemical process.

[0016] FIG. 10 is an illustrative embodiment of a comparison of carbon dioxide emissions from the processes provided in FIGS. 7-9 and a direct capture of carbon dioxide.

[0017] FIG. 11 is an illustrative embodiment of a typical process for converting trona to soda ash.

[0018] FIG. 12 is an illustrative embodiment of a process for producing soda ash from trona utilizing electrochemical process.

[0019] FIG. 13 provides an illustrative embodiment of an electrochemical system.

[0020] FIG. 14 provides an illustrative embodiment of an electrochemical system.

[0021] FIG. 15 provides an illustrative embodiment of an electrochemical system.

[0022] FIG. 16 provides an illustrative embodiment of an electrochemical system.

[0023] FIG. 17 provides an illustrative embodiment of a Solvay system integrated with the electrochemical system.

[0024] FIG. 18 provides an illustrative embodiment of a processing system.

[0025] FIG. 19 illustrates a plot comparing the performance between 10 wt % NaOH and 1 mol/L sodium bicarbonate solution in an electrochemical cell.

DESCRIPTION

[0026] Described herein are methods and systems to produce sodium carbonate by integrating Solvay process with electrochemical processes. The methods and systems provided herein are devoid of calcination of bicarbonate and lime as found in a conventional Solvay process, thereby providing a less carbon dioxide intensive Solvay process and an environmentally friendly sodium carbonate product.

[0027] It is to be understood that the invention is not limited to particular embodiments described herein as such embodiments may vary. It is also to be understood that the terminology used herein is for the purpose of describing particular embodiments only, and is not intended to be limiting, since the scope of the invention will be limited only by the appended claims. Unless defined otherwise, all technical and scientific terms used herein have the same meaning as commonly understood by one of ordinary skill in the art to which this invention belongs.

[0028] Where a range of values is provided, it is understood that each intervening value, to the tenth of the unit of the lower limit unless the context clearly dictates otherwise, between the upper and lower limit of that range and any other stated or intervening value in that stated range, is encompassed. The upper and lower limits of these smaller ranges may independently be included in the smaller ranges and are also encompassed, subject to any specifically excluded limit in the stated range. Where the stated range includes one or both of the limits, ranges excluding either or both of those included limits are also included.

[0029] Certain ranges are presented herein with numerical values being preceded by the term "about." The term "about" is used herein to provide literal support for the exact number that it precedes, as well as a number that is near to or approximately the number that the term precedes. In determining whether a number is near to or approximately a specifically recited number, the near or approximating unrecited number may be a number, which, in the context in which it is presented, provides the substantial equivalent of the specifically recited number.

[0030] All publications, patents, and patent applications cited in this specification are incorporated herein by reference to the same extent as if each individual publication, patent, or patent application were specifically and individually indicated to be incorporated by reference. Furthermore, each cited publication, patent, or patent application is incorporated herein by reference to disclose and describe the subject matter in connection with which the publications are cited. The citation of any publication is for its disclosure prior to the filing date and should not be construed as an admission that the claimed invention is not entitled to antedate such publication by virtue of prior invention. Further, the dates of publication provided may be different from the actual publication dates, which may need to be independently confirmed.

[0031] It is noted that, as used herein and in the appended claims, the singular forms "a," "an," and "the" include plural references unless the context clearly dictates otherwise. It is further noted that the claims may be drafted to exclude any optional element. As such, this statement is intended to serve as antecedent basis for use of such exclusive terminology as "solely," "only" and the like in connection with the recitation of claim elements, or use of a "negative" limitation.

[0032] As will be apparent to those of skill in the art upon reading this disclosure, each of the individual embodiments described and illustrated herein has discrete components and features which may be readily separated from or combined with the features of any of the other several embodiments. Any recited method can be carried out in the order of events recited or in any other order, which is logically possible. Although any methods and materials similar or equivalent to those described herein may also be used in the practice or testing of the invention, representative illustrative methods and materials are now described.

Methods and Systems

[0033] A "Solvay process," as used herein, includes any process that can be used to produce sodium carbonate using ammonia and carbon dioxide. About 25 percent of the world production of soda ash may be from natural sodium carbonate bearing deposits referred to as natural processes. For example, during the natural production process, trona (a principal ore from which natural soda ash may be made) may be calcined in a rotary kiln and chemically transformed into a crude soda ash. However, carbon dioxide is generated in the process. In the Solvay process, as illustrated in FIG. 1, sodium chloride brine, limestone, coke and ammonia are the raw materials in a series of reactions leading to the production of soda ash. Ammonia may be regenerated while a small amount may be lost. From the series of reactions illustrated in FIG. 1, CO₂ is generated in two calcination processes. The CO₂ generated may be captured, compressed and directed to Solvay precipitating towers for consumption in a mixture of brine (aqueous NaCl) and ammonia. However, there is net CO₂ emitted to the atmosphere during the production of soda ash because more CO₂ is produced by calcining limestone than is stoichiometrically required for absorption. The methods and systems described herein are related to the reduction of the CO₂ emission from the Solvay process by eliminating one or both of the calcining steps. The calcining steps of the Solvay process may be replaced by the electrochemical processes described herein.

[0034] The Solvay process (as illustrated in FIG. 1) benefits from modifications comprising one or more elements of the processing and/or electrochemical systems and methods

described herein. In some embodiments, for example, some of the carbon dioxide emitted from the Solvay process may be processed in accordance with any of the CO₂-processing methods described herein. In such embodiments, the carbon dioxide may originate from Reaction IV (“Bicarb Calcination”), Reaction II (“Lime Calcination”), or a combination thereof. In addition, calcium chloride, which is produced in Reaction III (“Regeneration”) in FIG. 1, may be used in some embodiments to produce calcium and/or magnesium carbonates (e.g., calcite, aragonite, vaterite, amorphous calcium carbonate) in the processes described herein. Such calcium and/or magnesium carbonates are useful in building materials such as cement, aggregate, supplementary cementitious materials, and the like. Alkaline waste and/or by-products of the Solvay process may also be used in the CO₂-process described herein.

[0035] In one aspect, there is provided a method to produce sodium carbonate, comprising a) absorbing carbon dioxide in an ammonia solution to form sodium bicarbonate; and b) subjecting the sodium bicarbonate to a first electrochemical process to produce sodium carbonate. In one aspect, there is provided a method to produce sodium carbonate, comprising a) absorbing carbon dioxide in an ammonia solution to form sodium bicarbonate; b) subjecting the sodium bicarbonate to a first electrochemical process to produce sodium carbonate; and c) regenerating the ammonia solution using calcium oxide obtained by lime calcinations. In one aspect, there is provided a method to produce sodium carbonate, comprising a) absorbing carbon dioxide in an ammonia solution to form sodium bicarbonate; b) subjecting the sodium bicarbonate to a first electrochemical process to produce sodium carbonate; and c) regenerating the ammonia solution using sodium hydroxide obtained from the first or a second electrochemical process. The first and/or the second electrochemical processes may be any electrochemical process described herein.

[0036] In another aspect, there is provided a method to modify a Solvay process to produce a less carbon dioxide intensive Solvay process, comprising a) absorbing carbon dioxide in an ammonia solution to form sodium bicarbonate; and b) subjecting the sodium bicarbonate to a first electrochemical process to produce sodium carbonate, thereby resulting in a less carbon dioxide intensive Solvay process. In one aspect, there is provided a method to modify a Solvay process to produce a less carbon dioxide intensive Solvay process, comprising a) absorbing carbon dioxide in an ammonia solution to form sodium bicarbonate; b) subjecting the sodium bicarbonate to a first electrochemical process to produce sodium carbonate; and c) regenerating the ammonia solution using calcium oxide obtained by lime calcinations, thereby resulting in a less carbon dioxide intensive Solvay process. In one aspect, there is provided a method to modify a Solvay process to produce a less carbon dioxide intensive Solvay process, comprising a) absorbing carbon dioxide in an ammonia solution to form sodium bicarbonate; b) subjecting the sodium bicarbonate to a first electrochemical process to produce sodium carbonate; and c) regenerating the ammonia solution using sodium hydroxide obtained from the first or a second electrochemical process, thereby resulting in a less carbon dioxide intensive Solvay process. The first and/or the second electrochemical processes may be any electrochemical process described herein. In some embodiments, the method described above and herein produces less than 80% carbon dioxide as compared to a conventional Solvay process. In some embodiments, the method described above and

herein produces less than 90%; or less than 80%; or less than 70%; or less than 60%; or less than 50%; or less than 40%; or less than 30%; or less than 20%; or less than 10%; or less than 5%; or less than 5-90%; or less than 5-80%; or less than 5-70%; or less than 5-60%; or less than 5-50%; or less than 5-40%; or less than 5-30%; or less than 5-20%; or less than 5-10%; or less than 10-80%; or less than 25-80%; or less than 50-80%; as compared to a conventional Solvay process.

[0037] For the methods described herein and as above, the methods do not include bicarbonate calcination, lime calcination, or a combination thereof.

[0038] FIGS. 2-5 provide some modifications to the Solvay process of FIG. 1. FIG. 2, for example, illustrates an electrochemical process in place of Reaction IV (“Bicarb Calcination”). The electrochemical process is as described herein. Details of such a modification, as provided in FIG. 2, show that Reaction IV of the modified process does not produce carbon dioxide, a distinct advantage over the existing Solvay process. FIG. 3, for example, illustrates an electrochemical process in place of Reaction II (“Lime Calcination”). The electrochemical process is as described herein. Details of such a modification, as provided in FIG. 3, show that Reaction II of the modified process does not produce carbon dioxide, a distinct advantage over the existing Solvay process. FIG. 4, for example, illustrates two electrochemical processes, one for Reaction IV (“Bicarb Calcination”) and the other for Reaction II (“Lime Calcination”). Details of such a modification as provided in FIG. 4, illustrate that Reactions II and IV of the modified process do not produce carbon dioxide, a distinct advantage over the existing Solvay process. FIG. 5, for example, illustrates a direct capture feature of FIG. 4 as well as a modified Reaction III (“Regeneration”). Some of the advantages of the modified Solvay process are lower demand for raw materials in Reactions I and III; less carbon dioxide emissions; and less energy intensive reactions (reduced or no calcinations). FIG. 5 shares the same soda ash product as the Solvay process but excises Reactions II and III and completely modifies Reactions I and II. Additional advantages of the processes provided in FIGS. 2-5 are provided in the Table I immediately below.

TABLE I

	Replace Bicarb Calcination	Replace Lime Calcination	Replace Both
CO ₂ Capture	50% of total CO ₂	100% of total CO ₂	100% of total CO ₂
Use of CaCO ₃	50% reduction	100% reduction	100% reduction
Capex	1) Bicarb calcination eliminated 2) NH ₃ absorption and lime calcination reduced by 50%	1) Lime calcination eliminated	1) Lime and bicarb calcination eliminated 2) NH ₃ absorption reduced by 50%

[0039] In addition to the advantages provided in the Table I, the processes of FIGS. 2-5 are less energy intensive and have smaller carbon footprint than the conventional Solvay process of FIG. 1. For example, FIG. 6 illustrates carbon dioxide emissions in tonnes CO₂/tonne of soda ash produced for the processes depicted in FIGS. 1-5, which correspond to “Solvay w/ Electrochemical process”, “Solvay w/ NaOH Regeneration”, “Solvay w/ two Electrochemical processes”, and “Direct Capture”. Advantageously, “Solvay w/ Electrochemical process”, “Solvay w/ NaOH Regeneration”,

“Solvay w/ two Electrochemical processes”, and “Direct Capture,” (respectively FIGS. 2-5) each emit less carbon dioxide (a measure of energy efficiency) than the Solvay process provided in FIG. 1. In one aspect, there is provided a method to produce sodium carbonate, comprising a) absorbing carbon dioxide in sodium carbonate solution to form sodium bicarbonate; and b) subjecting the sodium bicarbonate to an electrochemical process to produce sodium carbonate. In another aspect, there is provided a less carbon dioxide intensive method to produce sodium carbonate, comprising a) absorbing carbon dioxide in sodium carbonate solution to form sodium bicarbonate; and b) subjecting the sodium bicarbonate to an electrochemical process to produce sodium carbonate, thereby resulting in a less carbon dioxide intensive method to produce sodium carbonate. FIG. 7 illustrates a process using Searles Valley Minerals (SVM) for producing soda ash. A modification to the process is illustrated in FIG. 8. In accordance with previously described process modifications, the process of FIG. 8 replaces the bicarbonate calcination step with an electrochemical step, which electrochemical step does not release carbon dioxide. FIG. 9 provides a process for producing soda ash in which there is an electrochemical step replacing the bicarbonate calcination step along with recycling of acid. Additional details for the processes of FIGS. 8-9 are provided in each figure. Some of the advantages of the processes provided in FIGS. 8-9 are provided in the Table II below.

TABLE II

	SVM Brines w/ ABLE C	SVM Brines w/ Acid Recycle
Captured CO ₂	100% of total CO ₂	N/A
Brine usage	Reduces brine usage by 50%	N/A
Sodium sulfate	Available on site	Available on site (can be recycled and/or sold)
Sulfuric acid	Used on site (for borate processing)	Used on site (for brine titration)
Capex	1) Bicarb calcination eliminated	1) Bicarb calcination eliminated 2) MEA absorber and regeneration systems eliminated

[0040] In addition to the advantages provided in Table II, the processes of FIGS. 8-9 are less energy intensive and have smaller carbon footprints than the Searles Valley Minerals process of FIG. 7. For example, FIG. 10 illustrates carbon dioxide emissions in tonnes CO₂/tonne of soda ash produced for the processes depicted in FIGS. 8-9, which correspond to “Alkaline Brines w/ Electrochemical process,” “Alkaline Brines w/ Acid Recycle,” and “Direct Capture,” respectively, in FIG. 10. Advantageously, “Alkaline Brines w/ Electrochemical process,” “Alkaline Brines w/ Acid Recycle,” and “Direct Capture,” each emit less carbon dioxide (a measure of energy efficiency) than the Searles Valley Minerals process provided in FIG. 7. The direct capture is same as the direct capture provided in FIG. 5.

[0041] FIG. 11 illustrates a conventional trona ore process where trona is calcined to form soda ash. FIG. 12 illustrates modification to the trona-based method for producing soda ash, modifications including, but not limited to, use of electrochemistry and/or CO₂ processing (e.g., processing waste CO₂ produced by calcination of trona). FIG. 12 illustrates one such method for producing soda ash in a less carbon dioxide intensive manner. As illustrated, soda ash may be prepared

from trona ($\frac{1}{2}\text{Na}_2\text{CO}_3 \cdot \text{NaHCO}_3 \cdot 2\text{H}_2\text{O}$ (s)) utilizing electrochemistry in place of, or in combination with, calcination. As such, in some embodiments, trona may be mined and/or ground, for example, to a powder that may be used directly in electrolyte (e.g. catholyte) for the electrochemical cell or system thereof (e.g. stack of electrochemical cells), or purified before electrolyte use to remove impurities. While any of a number of additional salts may be used in electrolyte for the electrochemical cell(s) or system(s) thereof as described herein, FIG. 12 illustrates use of either Na₂SO₄ or NaCl, which provide anolytes comprising H₂SO₄ or HCl, respectively. Carbonates, as shown in FIG. 12 and described herein, may be electrochemically produced at a low voltage across the anode and the cathode (e.g., 1.2 V), which lowers the carbon dioxide footprint of the process provided in FIG. 12 when compared to the basic process provided in FIG. 11. Following production, such carbonates (e.g., Na₂CO₃) may be further processed including, but not limited to, liquid-solid separation, crystallization, recrystallization, and drying. As such, the system component corresponding to the mining/grinding step may comprise a mineral processor configured to comminute trona and other rocks/minerals; the system component corresponding to the electrochemical step may comprise an electrochemical cell or stack of electrochemical cells; and the system components corresponding to crystallization and drying may comprise a liquid-solid separator, a tank or analogous vessel for crystallization/recrystallization, and/or a dryer (e.g., spray dryer).

[0042] Advantageously, “Trona Ore w/ Electrochemical process” emits less carbon dioxide (a measure of energy efficiency) than the Trona Ore process provided in FIG. 11. In addition to the process of FIG. 12 being less energy intensive and having smaller carbon footprints than the Trona Ore process of FIG. 11, the process of FIG. 12 has additional advantages including, but not limited to, eliminating CO₂ emissions from calcination.

[0043] In one aspect, there is provide a system comprising a Solvay system integrated with an electrochemical system, comprising a) a Solvay system including an absorber configured to absorb carbon dioxide in an ammonia solution to form sodium bicarbonate; and b) a first electrochemical system operably connected to the Solvay system configured to convert the sodium bicarbonate to sodium carbonate. In another aspect, there is provide a system comprising a Solvay system integrated with an electrochemical system, comprising a) a Solvay system including an absorber configured to absorb carbon dioxide in an ammonia solution to form sodium bicarbonate; b) a first electrochemical system operably connected to the Solvay system configured to convert the sodium bicarbonate to sodium carbonate; and c) a regenerator operably connected to the Solvay system configured to regenerate the ammonia solution after absorption of the carbon dioxide in the ammonia solution. In yet another aspect, there is provide a system comprising a Solvay system integrated with an electrochemical system, comprising a) a Solvay system including an absorber configured to absorb carbon dioxide in an ammonia solution to form sodium bicarbonate; b) a first electrochemical system operably connected to the Solvay system configured to convert the sodium bicarbonate to sodium carbonate; c) a regenerator operably connected to the Solvay system configured to regenerate the ammonia solution after absorption of the carbon dioxide in the ammonia solution; and d) a lime calciner operably connected to the regenerator and configured to produce calcium oxide for regenerating the

ammonia solution. In yet another aspect, there is provide a system comprising a Solvay system integrated with an electrochemical system, comprising a) a Solvay system including an absorber configured to absorb carbon dioxide in an ammonia solution to form sodium bicarbonate; b) a first electrochemical system operably connected to the Solvay system configured to convert the sodium bicarbonate to sodium carbonate; c) a regenerator operably connected to the Solvay system configured to regenerate the ammonia solution after absorption of the carbon dioxide in the ammonia solution; and d) a second electrochemical system operably connected to the regenerator and configured to produce sodium hydroxide for regenerating the ammonia solution.

[0044] The Solvay system is any system known in the art to carry out the Solvay process. The absorber in the Solvay system may be any absorber configured to absorb carbon dioxide in an ammonia solution, such as, but not limited to, absorber configured for bubbling the carbon dioxide gas, stirrers for mixing the gas in the solution, packed bed for efficient contact between the gas and the solution, etc. In some embodiments, the solution charged with CO₂ is made by purging or diffusing the CO₂ gaseous stream through an ammonia solution to make a CO₂ charged solution containing sodium bicarbonate. In some embodiments, the CO₂ gas is bubbled or purged through a solution containing ammonia in the absorber. In some embodiments, the absorber may include a bubble chamber where the CO₂ gas is bubbled through the ammonia solution. In some embodiments, the absorber may include a spray tower where the ammonia solution is sprayed or circulated through the CO₂ gas. In some embodiments, the absorber may include a pack bed to increase the surface area of contact between the CO₂ gas and the ammonia solution. In some embodiments, a typical absorber fluid temperature is 32-37° C. For some embodiments, the absorber for absorbing CO₂ in the solution may be as described in U.S. application Ser. No. 12/721,549, filed on Mar. 10, 2010, which is incorporated herein by reference in its entirety.

[0045] The regenerator in the system described herein may be any system that can be used for regenerating ammonia (from ammonium chloride) where the system contains the base (such as calcium oxide from lime calcinations or sodium hydroxide from electrochemical process). For example, regenerator can be a tank, or a series of tanks, or container which may contain conduits or pipes to transfer and mix the ammonium salt solution and the base to regenerate ammonia. The ammonia formed may be transferred out of the tank or container using conduits or pipes.

[0046] The lime calciner in the system described herein may be any system that can be used for lime calcinations. Such calciners are well known in the art and are well within the scope of the invention.

[0047] In some embodiments, the sodium bicarbonate solution from the Solvay plant is transferred to the electrochemical system for the generation of soda ash. In some embodiments, the sodium hydroxide from the electrochemical systems is transferred to the Solvay plant for the regeneration of the ammonia solution. In some embodiments, there are provided methods and systems where the electrochemical systems of the invention are set up on-site of the Solvay process where sodium bicarbonate from the Solvay process is administered to the electrochemical system to generate soda ash and the sodium hydroxide from the electrochemical process is used to regenerate ammonia solution. In some embodiments, the electrochemical plant may be fitted close to the

Solvay plant eliminating transportation cost for waste products and allowing transportation of valuable products only.

[0048] The electrochemical systems are as described herein below.

Electrochemical Processes and Systems

[0049] The “electrochemical process” or “electrochemical system” used in the methods and systems described above and herein are described in this section. Accordingly, the methods and systems include one or more features of the electrochemical process and electrochemical cell described herein below. For example, the electrochemical process described in FIGS. 3 and/or 4 is any electrochemical process described herein that produces sodium hydroxide in the catholyte. Similarly, the electrochemical process described in FIGS. 2, 4, 5, 8, 9, and/or 12 is any electrochemical process described herein that contacts sodium bicarbonate solution with the catholyte.

[0050] Described herein are electrochemical systems and methods where the electrochemical cell electrolyzes a salt solution, such as, but not limited to, sodium chloride solution to produce sodium hydroxide in the catholyte and/or sodium carbonate ions and/or sodium bicarbonate in the catholyte, and an acid in the anolyte. The systems and methods are not limited to the use of sodium chloride solution as disclosed in the embodiments described herein as other salt solutions (e.g., aqueous potassium sulfate, Na₂SO₄ (aq), etc.) can be used to produce an equivalent result. In preparing the electrolytes for the system, water from various sources can be used including seawater, brackish water, brines or naturally occurring fresh water. In some embodiments, water may be purified to an acceptable level for use in the electrochemical system.

[0051] The electrochemical cell comprises an anode in contact with an anolyte; a cathode in contact with a catholyte; and an ion exchange membrane disposed between the catholyte and the anolyte. Accordingly, in one aspect, there is provided a system comprising a Solvay system integrated with an electrochemical system, comprising a) a Solvay system comprising an absorber configured to absorb carbon dioxide in an ammonia solution to form sodium bicarbonate; and b) a first electrochemical system operably connected to the Solvay system configured to convert the sodium bicarbonate to sodium carbonate wherein the electrochemical system comprises an anode in contact with an anolyte, a cathode in contact with a catholyte and one or more of ion exchange membrane.

[0052] In some embodiments of the electrochemical systems, with reference to FIG. 13 herein, in some embodiments the alkaline solution is produced in the catholyte of an electrochemical system 100 by electrolyzing a salt solution e.g., sodium chloride solution to produce the alkaline solution, e.g., sodium hydroxide in the catholyte, and an acid, e.g., hydrochloric acid in the anolyte. The anode and the cathode may be separated by an ion exchange membrane (IEM). As used herein, the catholyte is the electrolyte in contact with the cathode and configured to receive anions e.g., hydroxide ions from the cathode upon application of a voltage across the cathode and anode. The catholyte is in a cathode compartment. As used herein, the anolyte is an electrolyte in contact with the anode and configured to receive cations e.g., protons from the anode upon application of the voltage across the cathode and anode. The anolyte is in an anode compartment.

[0053] In some embodiments of the electrochemical system of FIG. 14, the salt solution e.g., a sodium chloride solution is placed in a salt solution compartment that is separated from the cathode compartment by a cation exchange membrane 206. In some embodiments, as illustrated in FIG. 15, the salt solution is separated from the anolyte compartment by an anion exchange membrane 210. The cathode 201 and the catholyte 202 form the cathode compartment and the anode 204 and the anolyte 203 form the anode compartment. Alkali 205 is formed in the catholyte 202 and an acid is formed in the anolyte 203.

[0054] In one aspect, there is provided a method to produce sodium carbonate, by a) absorbing carbon dioxide in an ammonia solution to form sodium bicarbonate; and b) subjecting the sodium bicarbonate to an electrochemical process to produce sodium carbonate wherein the electrochemical process comprises contacting anode with an anolyte, contacting cathode with a catholyte, and producing a base in the catholyte and an acid in the anolyte. In one aspect, there is provided a method to produce sodium carbonate, by a) absorbing carbon dioxide in an ammonia solution to form sodium bicarbonate; and b) subjecting the sodium bicarbonate to an electrochemical process to produce sodium carbonate wherein the electrochemical process comprises contacting anode with an anolyte, contacting cathode with a catholyte, producing hydrogen gas at the cathode, transferring hydrogen gas from the cathode to the anode, and producing a base in the catholyte and an acid in the anolyte. In some embodiments, the electrochemical process does not comprise producing a gas such as chlorine gas at the anode. In some embodiments, the electrochemical process comprises producing hydroxide at the cathode and hydrochloric acid (using sodium chloride as anolyte) or sulfuric acid (using sodium sulfate as anolyte) at the anode.

[0055] In one aspect, there is provided a method to modify a Solvay process to produce a less carbon dioxide intensive Solvay process, by a) absorbing carbon dioxide in an ammonia solution to form sodium bicarbonate; and b) subjecting the sodium bicarbonate to an electrochemical process to produce sodium carbonate, thereby resulting in a less carbon dioxide intensive Solvay process wherein the electrochemical process comprises contacting anode with an anolyte, contacting cathode with a catholyte, and producing a base in the catholyte and an acid in the anolyte. In one aspect, there is provided a method to modify a Solvay process to produce a less carbon dioxide intensive Solvay process, by a) absorbing carbon dioxide in an ammonia solution to form sodium bicarbonate; and b) subjecting the sodium bicarbonate to an electrochemical process to produce sodium carbonate, thereby resulting in a less carbon dioxide intensive Solvay process wherein the electrochemical process comprises contacting anode with an anolyte, contacting cathode with a catholyte, producing hydrogen gas at the cathode, transferring hydrogen gas from the cathode to the anode, and producing a base in the catholyte and an acid in the anolyte. In some embodiments, the electrochemical process does not comprise producing a gas such as chlorine gas at the anode. In some embodiments, the electrochemical process comprises producing hydroxide at the cathode and hydrochloric acid (using sodium chloride as anolyte) or sulfuric acid (using sodium sulfate as anolyte) at the anode.

[0056] In some embodiments, the alkaline solution is produced in the catholyte by reducing water at the cathode to hydroxide ions and hydrogen gas in accordance with Eq. 1, by

applying a voltage across the anode and cathode. In some embodiments, concurrent with the production of hydroxide ions and hydrogen gas at the cathode, at the anode hydrogen is oxidized to protons in accordance with Eq. 2:

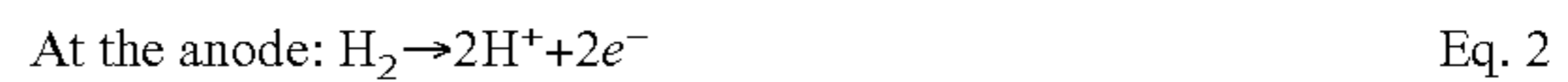
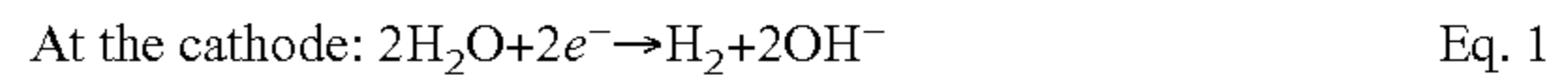

[0057] In some embodiments, on applying the voltage across the anode and cathode, hydroxide ions produced at the cathode migrate into the catholyte to produce the alkaline solution e.g., sodium hydroxide solution by combining with cations e.g., sodium ions in the catholyte. Concurrently, in some embodiments, under the applied voltage across the anode and cathode, the protons formed at the anode in accordance with Eq. 2 migrate into the anolyte and combine with anions in the anolyte e.g., chloride ions to produce an acid, e.g., hydrochloric acid in the anolyte. In some embodiments, the anions, e.g., chloride ions are migrated into the anolyte through the anion exchange membrane from the salt solution.

[0058] In some embodiments, hydrogen produced at the cathode is collected and directed to the anode for oxidation to protons as in Eq. 2. In some embodiments, since the hydrogen from the cathode is circulated to the anode therefore the need for externally produced hydrogen is reduced thereby reducing the overall energy expended in producing the alkaline solution. This type of the electrochemical cell and system, where the hydrogen gas is transferred from the cathode to the anode, has been described as ABLE in the provisional application to which priority has been claimed.

[0059] In some embodiments, the alkaline solution formed in the catholyte may be used to regenerate ammonia from the spent ammonia solution (used for sequestering carbon dioxide gas). In some embodiments, the alkaline solution may be also used to sequester carbon dioxide by absorbing the carbon dioxide in the catholyte in the cathode compartment or by absorbing the carbon dioxide in a gas absorber operatively connected to the cathode compartment configured to receive the catholyte and produce a carbonate or bicarbonate solution.

[0060] In one aspect, there is provided a method to produce sodium carbonate, by a) absorbing carbon dioxide in an ammonia solution to form sodium bicarbonate; b) subjecting the sodium bicarbonate to an electrochemical process to produce sodium carbonate wherein the electrochemical process comprises contacting anode with an anolyte, contacting cathode with a catholyte, and producing a base in the catholyte and an acid in the anolyte; and c) regenerating the ammonia solution using calcium oxide obtained by lime calcinations or regenerating the ammonia solution using sodium hydroxide obtained from the electrochemical process. In one aspect, there is provided a method to produce sodium carbonate, by a) absorbing carbon dioxide in an ammonia solution to form sodium bicarbonate; b) subjecting the sodium bicarbonate to an electrochemical process to produce sodium carbonate wherein the electrochemical process comprises contacting anode with an anolyte, contacting cathode with a catholyte, producing hydrogen gas at the cathode, transferring hydrogen gas from the cathode to the anode, and producing a base in the catholyte and an acid in the anolyte; and c) regenerating the ammonia solution using calcium oxide obtained by lime calcinations or regenerating the ammonia solution using sodium hydroxide obtained from the electrochemical process. In some embodiments, the electrochemical process does not comprise producing a gas such as chlorine gas at the anode. In

some embodiments, the electrochemical process comprises producing hydroxide at the cathode and hydrochloric acid (using sodium chloride as anolyte) or sulfuric acid (using sodium sulfate as anolyte) at the anode.

[0061] In one aspect, there is provided a method to modify a Solvay process to produce a less carbon dioxide intensive Solvay process, by a) absorbing carbon dioxide in an ammonia solution to form sodium bicarbonate; b) subjecting the sodium bicarbonate to an electrochemical process to produce sodium carbonate, thereby resulting in a less carbon dioxide intensive Solvay process wherein the electrochemical process comprises contacting anode with an anolyte, contacting cathode with a catholyte, and producing a base in the catholyte and an acid in the anolyte; and c) regenerating the ammonia solution using calcium oxide obtained by lime calcinations or regenerating the ammonia solution using sodium hydroxide obtained from the electrochemical process. In one aspect, there is provided a method to modify a Solvay process to produce a less carbon dioxide intensive Solvay process, by a) absorbing carbon dioxide in an ammonia solution to form sodium bicarbonate; b) subjecting the sodium bicarbonate to an electrochemical process to produce sodium carbonate, thereby resulting in a less carbon dioxide intensive Solvay process wherein the electrochemical process comprises contacting anode with an anolyte, contacting cathode with a catholyte, producing hydrogen gas at the cathode, transferring hydrogen gas from the cathode to the anode, and producing a base in the catholyte and an acid in the anolyte; and c) regenerating the ammonia solution using calcium oxide obtained by lime calcinations or regenerating the ammonia solution using sodium hydroxide obtained from the electrochemical process. In some embodiments, the electrochemical process does not comprise producing a gas such as chlorine gas at the anode. In some embodiments, the electrochemical process comprises producing hydroxide at the cathode and hydrochloric acid (using sodium chloride as anolyte) or sulfuric acid (using sodium sulfate as anolyte) at the anode.

[0062] In some embodiments of the system of FIG. 16, the alkaline solution 205 is produced wherein the catholyte 202 is separated from the anolyte 203 by a cation exchange membranes 206 and an anion exchange membrane 210 for cations to migrate from salt solution into the catholyte 202 through the cation exchange membrane 206 to produce the alkaline solution 205 in the catholyte 202, and for anions to migrate across an anion exchange membrane 210 to produce an acid in the anolyte 203. The ion exchange membranes comprising a cation exchange membrane separates the catholyte in the cathode compartment from a third electrolyte. In various embodiments, the ion exchange membrane comprises an anion exchange membrane separating the anolyte from the third electrolyte. In various embodiments, the third electrolyte comprises sodium ions and chloride ions; the system is configured to migrate sodium ions from the third electrolyte to catholyte through the cation exchange membrane, and migrate chloride ions from the third electrolyte to the anolyte through the anion exchange membrane.

[0063] In some embodiments, the systems described herein may include a second cation exchange membrane (not shown in figures) that is in contact with the anode. In some embodiments, there may be an additional chamber between the anion exchange membrane and the anode, such as, a gas diffusion anode (not shown in Figs). The liquid chamber is in close

contact with the anode and the anion exchange membrane which anion exchange membrane is further in contact with the center salt compartment.

[0064] As disclosed in U.S. Provisional Patent Application No. 61/081,299, filed 16 Jul. 2008, titled, "Low Energy pH Modulation for Carbon Sequestration Using Hydrogen Absorptive Metal Catalysts," herein incorporated by reference in its entirety, in various embodiments, the anode and the cathode of the present system may comprise a noble metal, a transition metal, a platinum group metal, a metal of Groups IVB, VB, VIB, or VIII of the periodic table of elements, alloys of these metals, or oxides of these metals. Exemplary materials include palladium, platinum, iridium, rhodium, ruthenium, titanium, zirconium, chromium, iron, cobalt, nickel, palladium-silver alloys, and palladium-copper alloys. In various embodiments, the cathode and/or the anode may be coated with a reactive coating comprising a metal, a metal alloy, or an oxide, formed by sputtering, electroplating, vapor deposition, or any convenient method of producing a layer of reactive coating on the surface of the cathode and/or anode. In other embodiments, the cathode and/or the anode may comprise a coating designed to provide selective penetration and/or release of certain chemicals or hydroxide ions and/or antifouling protection. Exemplary coatings include non-metallic polymers; in specific embodiments herein, an anode fabricated from a 20-mesh Ni gauze material, and a cathode fabricated from a 100-mesh Pt gauze material was used.

[0065] Reduction of water at the cathode produces hydroxide ions that migrate into the catholyte. The production of hydroxide ions in the catholyte surrounding the cathode may increase the pH of the catholyte. In various embodiments, the solution with the elevated pH is used in situ, or is drawn off and utilized in a separate reaction, e.g., to react with sodium bicarbonate as described herein. Depending on the balance of the rate of hydroxide ion production versus the rate of carbonate formation in the catholyte, it is possible for the pH to remain the same or even decrease, as hydroxide ions are consumed in the reaction.

[0066] Oxidation of hydrogen gas at the anode results in production of hydrogen ions at the anode that desorb from the structure of the anode and migrate into the electrolyte surrounding the anode, resulting in a lowering of the pH of the anolyte. Thus, the pH of the electrolytes in the system can be adjusted by controlling the voltage across the cathode and anode and using electrodes comprised of a material capable of absorbing or desorbing hydrogen ions. In various embodiments, the process generates hydroxide ions in solution with less than a 1:1 ratio of CO₂ molecules released into the environment per hydroxide ion generated. In various embodiments, the anolyte enriched with hydrogen ions (i.e. an acid), can be utilized for a variety of applications including dissolving minerals to produce a solution of divalent cations (e.g. calcium and/or magnesium ions) for use in generating carbonate/bicarbonate products.

[0067] In one aspect, there is provided a system comprising a Solvay system integrated with an electrochemical system, comprising a) a Solvay system comprising an absorber configured to absorb carbon dioxide in an ammonia solution to form sodium bicarbonate; and b) a first electrochemical system operably connected to the Solvay system configured to convert the sodium bicarbonate to sodium carbonate wherein the electrochemical system comprises an anode in contact with an anolyte, a cathode in contact with a catholyte; one or more of ion exchange membrane; and a hydrogen gas delivery

system operably connected to the cathode compartment and configured to transfer hydrogen gas from the cathode to the anode.

[0068] In one aspect, there is provided a system comprising a Solvay system integrated with an electrochemical system, comprising a) a Solvay system comprising an absorber configured to absorb carbon dioxide in an ammonia solution to form sodium bicarbonate; b) a first electrochemical system operably connected to the Solvay system configured to convert the sodium bicarbonate to sodium carbonate wherein the electrochemical system comprises an anode in contact with an anolyte, a cathode in contact with a catholyte; one or more of ion exchange membrane; and a hydrogen gas delivery system operably connected to the cathode compartment and configured to transfer hydrogen gas from the cathode to the anode; and c) a regenerator operably connected to the Solvay system configured to regenerate the ammonia solution after absorption of the carbon dioxide in the ammonia solution.

[0069] In one aspect, there is provided a system comprising a Solvay system integrated with an electrochemical system, comprising a) a Solvay system comprising an absorber configured to absorb carbon dioxide in an ammonia solution to form sodium bicarbonate; b) a first electrochemical system operably connected to the Solvay system configured to convert the sodium bicarbonate to sodium carbonate wherein the electrochemical system comprises an anode in contact with an anolyte, a cathode in contact with a catholyte; one or more of ion exchange membrane; and a hydrogen gas delivery system operably connected to the cathode compartment and configured to transfer hydrogen gas from the cathode to the anode; c) a regenerator operably connected to the Solvay system configured to regenerate the ammonia solution after absorption of the carbon dioxide in the ammonia solution; and d) a lime calciner operably connected to the regenerator and configured to produce calcium oxide for regenerating the ammonia solution.

[0070] In one aspect, there is provided a system comprising a Solvay system integrated with an electrochemical system, comprising a) a Solvay system comprising an absorber configured to absorb carbon dioxide in an ammonia solution to form sodium bicarbonate; b) a first electrochemical system operably connected to the Solvay system configured to convert the sodium bicarbonate to sodium carbonate wherein the electrochemical system comprises an anode in contact with an anolyte, a cathode in contact with a catholyte; one or more of ion exchange membrane; and a hydrogen gas delivery system operably connected to the cathode compartment and configured to transfer hydrogen gas from the cathode to the anode; c) a regenerator operably connected to the Solvay system configured to regenerate the ammonia solution after absorption of the carbon dioxide in the ammonia solution; and d) a second electrochemical system operably connected to the regenerator and configured to produce sodium hydroxide for regenerating the ammonia solution.

[0071] The first and second electrochemical processes and/or first and second electrochemical systems, as described herein, may be the same electrochemical systems and process or may be different electrochemical processes and systems. For example, in some embodiments, the first electrochemical process and system may be the one described in FIG. 13 and the second electrochemical process and system may be the one described in FIG. 14, or vice versa. For example, in some embodiments, the first electrochemical process and system may be the one described in FIG. 14 and the second electro-

chemical process and system may be the one described in FIG. 15, or vice versa. For example, in some embodiments, the first electrochemical process and system may be the one described in FIG. 15 and the second electrochemical process and system may be the one described in FIG. 16, or vice versa. For example, in some embodiments, the first electrochemical process and system may be the same such as the one described in FIG. 13, 14, 15, or 16.

[0072] In some embodiments, the system includes an inlet system configured to deliver sodium bicarbonate solution (e.g. solution containing bicarbonate/carbonate ions obtained by absorbing carbon dioxide gas with ammonia solution) into the catholyte compartment. In some embodiments, the cathode compartment of the electrochemical system is operably connected to an absorber that contains ammonia and is connected to carbon dioxide obtained from Solvay process or from any other plant, such as steel, cement, or power plant. The ammonia solution in the absorber after absorbing the carbon dioxide forms a carbon dioxide charged solution containing bicarbonate and/or carbonate ions and a spent ammonia (such as ammonium chloride). This bicarbonate and/or carbonate ion containing solution may then be transferred to the cathode compartment of the electrochemical system where the sodium hydroxide generated by the cathode may convert the remaining bicarbonate to sodium carbonate resulting in soda ash formation. This type of the electrochemical cell and system has been described as ABLE-C in the provisional application to which priority has been claimed. In some embodiments, the sodium bicarbonate solution from the absorber may be contacted with the sodium hydroxide from the electrochemical cell, outside the electrochemical cell, such that the sodium bicarbonate solution is not administered to the cathode compartment. As such, similar reaction takes place between the sodium bicarbonate from the absorber and sodium hydroxide from the catholyte to form sodium carbonate.

[0073] As illustrated in FIG. 17, a first electrochemical process 400 of FIG. 16 is operably connected to the absorber 500 of the Solvay system. The ammonia solution in the absorber 500 absorbs carbon dioxide gas and dissolves it to form sodium bicarbonate solution (this solution may contain sodium carbonate too). The sodium bicarbonate solution may be then added to the cathode compartment of the first electrochemical process where the hydroxide ions generated at the cathode convert sodium bicarbonate to sodium carbonate (soda ash). As noted above, in some embodiments, the sodium bicarbonate solution may be contacted with the sodium hydroxide from the catholyte outside the electrochemical cell (not shown in the figure). The spent ammonia in the absorber (e.g., NH_4Cl) may be then treated with sodium hydroxide generated at the cathode in the second electrochemical process, to regenerate ammonia solution. The regenerated ammonia may be transferred back to the absorber 500. The first and the second electrochemical systems may be same (as illustrated in FIG. 17) or may be different, as described herein.

[0074] In various embodiments, the absorber includes a gas mixer/gas absorber that enhances the absorption of CO_2 in ammonia. In one embodiment, the gas mixer/gas absorber includes a series of spray nozzles that produce a flat sheet or curtain of liquid through which the gas is directed for absorption; in another embodiment the gas mixer/gas absorber includes spray absorber that creates a mist into which the gas is directed for absorption; other commercially available gas/

liquid absorber e.g., an absorber available from Neumann Systems, Colorado, USA may be used. In operation, the cathode and anode compartments are filled with electrolytes and a voltage is applied across the cathode and anode. In various embodiments, the voltage is adjusted to a level to cause production of hydrogen gas at the cathode without producing a gas, e.g., chlorine or oxygen, at the anode. In various embodiments, the system includes a cathode and an anode that facilitate reactions whereby the catholyte is enriched with hydroxide ions and the anolyte is enriched with hydrogen ions.

[0075] In various embodiments, a conductive electrolyte solution can be employed as the electrolyte solution within the reservoir and in some embodiments the electrolyte solution comprises seawater, brine, or brackish water.

[0076] As disclosed herein, in various embodiments, hydroxide ions are produced in the catholyte by applying a relatively low voltage, e.g., less than 3.0 V, such as less than 2.0 V, or less than 1.0 V or less than 0.8 V or less than 0.6 V or less than 0.4 V across the cathode and anode. In various embodiments, hydroxide ions are produced from water in the catholyte in contact with the cathode, and carbonate ions are produced in the catholyte by dissolving sodium bicarbonate solution in the catholyte in the catholyte compartment. In some embodiments, the electrochemical system comprises a hydrogen gas delivery system configured to direct hydrogen gas produced at the cathode to the anode.

[0077] In some embodiments, the catholyte is operatively connected to the absorber configured to dissolve carbon dioxide in ammonia; the system is configured to produce a pH differential (ΔpH) between 0 and 14 or greater between the anolyte and catholyte. For example, ΔpH may be zero when the catholyte and anolyte are of equal pH, or ΔpH may be 14 when the catholyte is pH 14 and the anolyte is pH 0. As such, ΔpH between the anolyte and catholyte may be greater than 0, 1, 2, 3, 4, 5, 6, 7, 8, 9, 10, 11, 12, or 13; ΔpH between the anolyte and catholyte may be less than 14, 13, 12, 11, 10, 9, 8, 7, 6, 5, 4, 3, 2, or 1. By the method, acid produced in the anolyte is utilized to dissolve a mafic mineral and/or a cellulose material.

[0078] In various embodiments, a gas, e.g., oxygen or chlorine is not produced at the anode; in various embodiments, hydrogen gas from an external source is provided to the anode where it is oxidized to hydrogen ions that migrate into the anolyte to produce an acid in the anolyte.

[0079] In various embodiments, hydroxide ions produced at the cathode in the second catholyte compartment migrate into the catholyte and may cause the pH of the catholyte to adjust, e.g., the pH of the catholyte may increase, decrease or remain the same, depending on the rate of removal of catholyte from the system. In various embodiments, the pH of the catholyte is adjusted by producing hydroxide ions from water at the cathode, and allowing the hydroxide ions to migrate into the catholyte. The pH is also adjusted by dissolving sodium bicarbonate solution in the catholyte to produce carbonate ions.

[0080] In some embodiments, the overall cell potential of the system can be determined through the Gibbs energy change of the reaction by the formula:

$$E_{\text{cell}} = -\Delta G/nF$$

[0081] Or, at standard temperature and pressure conditions:

$$E^{\circ}_{\text{cell}} = -\Delta G^{\circ}/nF$$

where, E_{cell} is the cell voltage, ΔG is the Gibbs energy of reaction, n is the number of electrons transferred, and F is the

Faraday constant (96485 J/V·mol). The E_{cell} of each of these reactions is pH dependent based on the Nernst equation.

[0082] The overall cell potential can be determined through the combination of Nernst equations for each half cell reaction:

$$E = E^{\circ} - RT \ln(Q)/nF$$

where, E° is the standard reduction potential, R is the universal gas constant, (8.314 J/mol K) T is the absolute temperature, n is the number of electrons involved in the half cell reaction, F is Faraday's constant (96485 J/V mol), and Q is the reaction quotient such that:

$$E_{\text{total}} = E_{\text{cathode}} + E_{\text{anode}}$$

[0083] When hydrogen is oxidized to protons at the anode as follows:

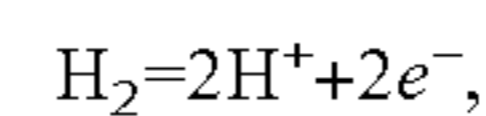

[0084] E° is 0.00 V, n is 2, and Q is the square of the activity of H^+ so that:

$$E_{\text{anode}} = +0.059\text{pH}_a$$

[0085] where pH_a is the pH of the anolyte.

[0086] When water is reduced to hydroxide ions and hydrogen gas at the cathode as follows:

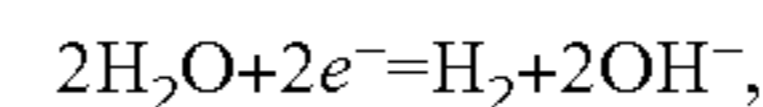

[0087] E° is -0.83 V, n is 2, and Q is the square of the activity of OH^- — so that:

$$E_{\text{cathode}} = -0.059\text{pH}_c$$

where pH_c is the pH of the catholyte.

[0088] Therefore, the E for the cathode and anode reactions varies with the pH of the anode and catholytes. Thus, if the anode reaction, which is occurring in an acidic environment, is at a pH of 0, then the E of the reaction is 0 V for the half cell reaction. For the cathode reaction, if the generation of bicarbonate ions occur at a pH of 7, then the theoretical E is $7 \times (-0.059 \text{ V}) = -0.413 \text{ V}$ for the half cell reaction where a negative E means energy is needed to be input into the half cell or full cell for the reaction to proceed. Thus, if the anode pH is 0 and the cathode pH is 7 then the overall cell potential would be 0.413 V, where:

$$E_{\text{total}} = -0.059(\text{pH}_a - \text{pH}_c) = -0.059\Delta\text{pH}$$

[0089] Embodiments in which carbonate ions are produced, if the anode pH is 0 and the cathode pH is 10, this would represent an E of 0.59 V.

[0090] Thus, in various embodiments, directing bicarbonate solution into the catholyte may lower the pH of the catholyte by producing carbonate ions in the catholyte, and also lower the voltage across the anode and cathode to produce hydroxide, carbonate and/or bicarbonate in the catholyte. Thus, operation of the electrochemical cell with the cathode pH at 7 or greater may provide a significant energy savings.

[0091] In various embodiments, for different pH values in the catholyte and the anolyte, hydroxide ions, carbonate ions and/or bicarbonate ions are produced in the catholyte when the voltage applied across the anode and cathode was less than 3.0 V, 2.9 V, 2.8 V, 2.7 V, 2.6 V, 2.5 V, 2.4 V, 2.3 V, 2.2 V, 2.1 V, 2.0 V, 1.9 V, 1.8 V, 1.7 V, 1.6 V, 1.5 V, 1.4 V, 1.3 V, 1.2 V, 1.1 V, 1.0 V, 0.9 V, 0.8 V, 0.7 V, 0.6 V, 0.5 V, 0.4 V, 0.3 V, 0.2 V, or 0.1 V. For selected voltages in the above range, the pH differential (ΔpH) between the anolyte and the catholyte may be between 0 and 14 or greater. For example, ΔpH may be

zero when the catholyte and anolyte are of equal pH, or ΔpH may be 14 when the catholyte is pH 14 and the anolyte is pH 0. As such, ΔpH between the anolyte and catholyte may be greater than 0, 1, 2, 3, 4, 5, 6, 7, 8, 9, 10, 11, 12, or 13; ΔpH between the anolyte and catholyte may be less than 14, 13, 12, 11, 10, 9, 8, 7, 6, 5, 4, 3, 2, or 1.

[0092] In various embodiments, the system and method are configurable for batch, semi-batch or continuous flow operation with or without the option to withdraw portions of the sodium hydroxide produced in the catholyte, or withdraw all or a portions of the acid produced in the anolyte, or direct the hydrogen gas produced at the cathode to the anode where it may be oxidized.

[0093] In various embodiments, hydroxide ions, bicarbonate ions and/or carbonate ion solutions are produced in the catholyte when the voltage applied across the anode and cathode is less than 3.0 V, 2.9 V or less, 2.8 V or less, 2.7 V or less, 2.6 V or less, 2.5 V or less, 2.4 V or less, 2.3 V or less, 2.2 V or less, 2.1 V or less, 2.0 V or less, 1.9 V or less, 1.8 V or less, 1.7 V or less, 1.6 V, or less 1.5 V or less, 1.4 V or less, 1.3 V or less, 1.2 V or less, 1.1 V or less, 1.0 V or less, 0.9 V or less or less, 0.8 V or less, 0.7 V or less, 0.6 V or less, 0.5 V or less, 0.4 V or less, 0.3 V or less, 0.2 V or less, or 0.1 V or less.

[0094] In another embodiment, the voltage across the anode and cathode can be adjusted such that gas will form at the anode, e.g., oxygen or chlorine, while hydroxide ions, carbonate ions and bicarbonate ions are produced in the catholyte and hydrogen gas is generated at the cathode. However, in this embodiment, hydrogen gas is not supplied to the anode. As can be appreciated by one ordinarily skilled in the art, in this embodiment, the voltage across the anode and cathode will be higher compared to the embodiment when a gas does not form at the anode.

[0095] The anion exchange membrane and the cation exchange membrane, as described herein, can be conventional ion exchange membranes. In some embodiments, the membranes are capable of functioning in an acidic and/or basic electrolytic solution and exhibit high ion selectivity, low ionic resistance, high burst strength, and high stability in an acidic electrolytic solution in a temperature range of 0° C. to 100° C. or higher. In some embodiments a membrane stable in the range of 0° C. to 80° C., or 0° C. to 90° C., but not stable above these ranges may be used. Suitable membranes include a Teflon™-based cation exchange membrane available from Asahi Kasei of Tokyo, Japan. However, low cost hydrocarbon-based cation exchange membranes can also be utilized, e.g., the hydrocarbon-based membranes available from, e.g., Membrane International of Glen Rock, N.J., and USA.

[0096] In some embodiments, the electrolyte including the catholyte or the cathode electrolyte and/or the anolyte or the anode electrolyte, or the third electrolyte disposed between AEM and CEM, in the systems and methods provided herein include, but not limited to, saltwater or fresh water. The saltwater includes, but is not limited to, seawater, brine, and/or brackish water. "Saltwater" is employed in its conventional sense to refer to a number of different types of aqueous fluids, where the term "saltwater" includes, but is not limited to, brackish water, sea water and brine (including, naturally occurring subterranean brines or anthropogenic subterranean brines and man-made brines, e.g., geothermal plant wastewaters, desalination waste waters, etc), as well as other salines having a salinity that is greater than that of freshwater. Brine is water saturated or nearly saturated with salt and has a salinity that is 50 ppt (parts per thousand) or greater. Brackish

water is water that is saltier than fresh water, but not as salty as seawater, having a salinity ranging from 0.5 to 35 ppt. Seawater is water from a sea or ocean and has a salinity ranging from 35 to 50 ppt. The saltwater source may be a naturally occurring source, such as a sea, ocean, lake, swamp, estuary, lagoon, etc., or a man-made source. In some embodiments, the systems provided herein include the saltwater from terrestrial brine. In some embodiments, the depleted saltwater withdrawn from the electrochemical cells is replenished with salt and re-circulated back in the electrochemical cell.

[0097] In some embodiments, the electrolyte including the cathode electrolyte and/or the anode electrolyte and/or the third electrolyte, such as, saltwater includes water containing more than 1% chloride content, such as, NaCl; or more than 10% NaCl; or more than 20% NaCl; or more than 30% NaCl; or more than 40% NaCl; or more than 50% NaCl; or more than 60% NaCl; or more than 70% NaCl; or more than 80% NaCl; or more than 90% NaCl; or between 1-99% NaCl; or between 1-95% NaCl; or between 1-90% NaCl; or between 1-80% NaCl; or between 1-70% NaCl; or between 1-60% NaCl; or between 1-50% NaCl; or between 1-40% NaCl; or between 1-30% NaCl; or between 1-20% NaCl; or between 1-10% NaCl; or between 10-99% NaCl; or between 10-95% NaCl; or between 10-90% NaCl; or between 10-80% NaCl; or between 10-70% NaCl; or between 10-60% NaCl; or between 10-50% NaCl; or between 10-40% NaCl; or between 10-30% NaCl; or between 10-20% NaCl; or between 20-99% NaCl; or between 20-95% NaCl; or between 20-90% NaCl; or between 20-80% NaCl; or between 20-70% NaCl; or between 20-60% NaCl; or between 20-50% NaCl; or between 20-40% NaCl; or between 20-30% NaCl; or between 30-99% NaCl; or between 30-95% NaCl; or between 30-90% NaCl; or between 30-80% NaCl; or between 30-70% NaCl; or between 30-60% NaCl; or between 30-50% NaCl; or between 30-40% NaCl; or between 40-99% NaCl; or between 40-95% NaCl; or between 40-90% NaCl; or between 40-80% NaCl; or between 40-70% NaCl; or between 40-60% NaCl; or between 40-50% NaCl; or between 50-99% NaCl; or between 50-95% NaCl; or between 50-90% NaCl; or between 50-80% NaCl; or between 50-70% NaCl; or between 50-60% NaCl; or between 60-99% NaCl; or between 60-95% NaCl; or between 60-90% NaCl; or between 60-80% NaCl; or between 60-70% NaCl; or between 70-99% NaCl; or between 70-95% NaCl; or between 70-90% NaCl; or between 70-80% NaCl; or between 80-99% NaCl; or between 80-95% NaCl; or between 80-90% NaCl; or between 90-99% NaCl; or between 90-95% NaCl. In some embodiments, the above recited percentages apply to sodium sulfate as an electrolyte.

[0098] In some embodiments, the cathode compartment may also be operatively connected to a waste gas treatment system (not illustrated) where the base solution produced in the catholyte is utilized, e.g., to sequester carbon dioxide contained in the waste gas by contacting the waste gas and the catholyte with a solution of divalent cations to precipitate hydroxides, carbonates and/or bicarbonates as described in U.S. patent application Ser. No. 12/344,019, filed 24 Dec. 2008, which is incorporated herein by reference in its entirety.

[0099] In some embodiments, the sodium carbonate (soda ash) may be treated with divalent cations, such as calcium or magnesium ions, to precipitate calcium and magnesium carbonates which may be utilized as building materials, e.g., as cements and aggregates, as described in U.S. patent application Ser. No. 12/126,776, filed 23 May 2008, which is incorporated herein by reference in its entirety. In some embodi-

ments, some or all of the carbonates and/or bicarbonates are allowed to remain in an aqueous medium, e.g., a slurry or a suspension, and are disposed of in an aqueous medium, e.g., in the ocean depths.

[0100] In some embodiments, the cathode and anode are also operatively connected to an off-peak electrical power-supply system that supplies off-peak voltage to the electrodes. Since the cost of off-peak power is lower than the cost of power supplied during peak power-supply times, the system can utilize off-peak power to produce a base solution in the catholyte at a relatively lower cost.

[0101] In some embodiments, partially desalinated water is produced in the third electrolyte as a result of migration of cations and anions from the third electrolyte to the adjacent anolyte and catholyte. In various embodiments, the partially desalinated water is operatively connected to a desalination system (not illustrated) where it is further desalinated as described in U.S. patent application Ser. No. 12/163,205, filed 27 Jun. 2008, which is incorporated herein by reference in its entirety.

[0102] In some embodiments, the system produces an acid, e.g., hydrochloric acid in the anolyte. In some embodiments, the anode compartment is operably connected to a system for dissolving minerals and waste materials comprising divalent cations to produce a solution of divalent cations, e.g., Ca^{2+} and Mg^{2+} . In some embodiments, the divalent cation solution may be utilized to precipitate divalent carbonates and/or bicarbonates by contacting the divalent cation solution with sodium carbonate solution. In various embodiments, the precipitates are used as building materials e.g., cement and aggregates as described in U.S. patent application Ser. No. 12/126,776, which is incorporated herein by reference in its entirety.

[0103] In some embodiments, the system includes a catholyte withdrawal and replenishing system (not illustrated) capable of withdrawing all of, or a portion of, the catholyte from the cathode compartment. In some embodiments, the system also includes a salt solution supply system (not shown) for providing a salt solution, e.g., concentrated sodium chloride, as the third electrolyte. In some embodiments, the system also includes inlet ports (not shown) for introducing fluids into the cells and outlet ports (not shown) for removing fluids from the cells.

[0104] In the present system since a gas does not form at the anode, the system may produce hydroxide ions in the catholyte and hydrogen gas at the cathode and hydrogen ions at the anode when less than 2.0 V is applied across the anode and cathode, in contrast to the higher voltage that is required when a gas is generated at the anode, e.g., chlorine or oxygen. As will be appreciated by one ordinarily skilled in the art, by not forming a gas at the anode and by providing hydrogen gas to the anode for oxidation at the anode, and by otherwise controlling the resistance in the system for example by decreasing the electrolyte path lengths and by selecting ionic membranes with low resistance and any other method known in the art, hydroxide ions can be produced in the catholyte with the present lower voltages.

[0105] In various embodiments, depending on the ionic species desired in the system, alternative reactants can be utilized. Thus, for example, if a potassium salt such as potassium hydroxide or potassium carbonate is desired in the cathode electrolyte, then a potassium salt such as potassium chlo-

ride can be utilized as an electrolyte. Similarly, if sulfuric acid is desired in the anolyte, then a sulfate such as sodium sulfate can be utilized in electrolyte.

[0106] In some embodiments, the system and method described herein are integrated with a carbonate and/or bicarbonate precipitation system wherein a solution of divalent cations, when added to the catholyte containing sodium carbonate, causes formation of precipitates of divalent carbonate and/or bicarbonate compounds, e.g., calcium carbonate or magnesium carbonate and/or their bicarbonates. In various embodiments, the precipitated divalent carbonate and/or bicarbonate compounds may be utilized as building materials, e.g., cements and aggregates as described for example in U.S. patent application Ser. No. 12/126,776, filed 23 May 2008, which is incorporated herein by reference in its entirety.

[0107] In some embodiments, the system and method described herein are integrated with a mineral and/or material dissolution and recovery system (not illustrated) wherein the acidic anolyte solution is utilized to dissolve calcium and/or magnesium-rich minerals e.g., serpentine or olivine, or waste materials, e.g., fly ash, red mud and the like, to form divalent cation solutions that may be utilized, e.g., to precipitate carbonates and/or bicarbonates as described herein.

[0108] In some embodiments, the system and method described herein are integrated with an aqueous desalination system (not illustrated) wherein the partially desalinated water of the third electrolyte of the system is used as feed-water for the desalination system, as described in U.S. patent application Ser. No. 12/163,205, filed 27 Jun. 2008, which is incorporated herein by reference in its entirety.

[0109] In some embodiments, the system and method described herein are integrated with a carbonate and/or bicarbonate solution disposal system (not illustrated) wherein, rather than producing precipitates by contacting a solution of divalent cations with sodium carbonate to form precipitates, the system produces a slurry or suspension comprising carbonates and/or bicarbonates. In various embodiments, the slurry or suspension is disposed of in a location where it is held stable for an extended periods of time, e.g., the slurry/suspension is disposed in an ocean at a depth where the temperature and pressure are sufficient to keep the slurry stable indefinitely, as described in U.S. patent application Ser. No. 12/344,019, filed 24 Dec. 2008, which is herein incorporated by reference in its entirety.

[0110] In some embodiments, the systems provided herein may include a processor to process the compositions containing bicarbonate and/or carbonate products. An illustrative example of the processor is described in FIG. 18. For example, in some embodiments, the processor includes a reactor configured to react soda ash obtained from the electrochemical system (such as FIGS. 13-17 described herein) with divalent cations from a source of divalent cations to produce compositions containing carbonate/bicarbonate products. In some embodiments, the processor may further comprise a settling tank configured for settling compositions. The processor may further comprise a treatment system configured to concentrate compositions comprising carbonates, bicarbonates, or carbonates and bicarbonates and produce a supernatant; however, in some embodiments the compositions may be used without further treatment. For example, systems may be configured to directly use compositions from the reactor (optionally with minimal post-processing) in the manufacture of building materials. In another non-limiting example, systems may be configured to directly inject com-

positions from the processor (optionally with minimal post-processing) into a subterranean site as described in U.S. Provisional Patent Application No. 61/232,401, filed 7 Aug. 2009, which is incorporated herein by reference in its entirety. The source of divalent cations may be from any of a variety of sources of divalent cations, including, but not limited to, seawater, brines, and freshwater with added minerals. In some embodiments, the source of divalent cations comprises divalent cations of alkaline earth metals (e.g., Ca^{2+} , Mg^{2+}).

[0111] The treatment system may comprise a liquid-solid separator or some other dewatering system configured to treat processor-produced compositions to produce supernatant and concentrated compositions (e.g., concentrated with respect to carbonates and/or bicarbonates). The treatment system may further comprise a filtration system, wherein the filtration system comprises at least one filtration unit configured for filtration of supernatant from the dewatering system, filtration of the composition from the processor, or a combination thereof. For example, in some embodiments, the filtration system comprises one or more filtration units selected from a microfiltration unit, an ultrafiltration unit, a nanofiltration unit, and a reverse osmosis unit. In some embodiments, the processing system comprises a nanofiltration unit configured to increase the concentration of divalent cations in the retentate and reduce the concentration of divalent cations in the filtrate. In such embodiments, nanofiltration unit retentate may be recirculated to a processor of the system for producing compositions described herein.

[0112] In some embodiments, the calcium carbonate composition formed by the processes described herein comprises vaterite, aragonite, amorphous calcium carbonate, calcite, or combination thereof. In some embodiments, such calcium carbonate (optionally containing magnesium carbonate) forms a cementitious material. The cementitious composition has elements or markers that originate from the carbon from the source of carbon used in the process. The composition after setting, and hardening has a compressive strength of at least 14 MPa; or at least 16 MPa; or at least 18 MPa; or at least 20 MPa; or at least 25 MPa; or at least 30 MPa; or at least 35 MPa; or at least 40 MPa; or at least 45 MPa; or at least 50 MPa; or at least 55 MPa; or at least 60 MPa; or at least 65 MPa; or at least 70 MPa; or at least 75 MPa; or at least 80 MPa; or at least 85 MPa; or at least 90 MPa; or at least 95 MPa; or at least 100 MPa; or from 14-100 MPa; or from 14-80 MPa; or from 14-75 MPa; or from 14-70 MPa; or from 14-65 MPa; or from 14-60 MPa; or from 14-55 MPa; or from 14-50 MPa; or from 14-45 MPa; or from 14-40 MPa; or from 14-35 MPa; or from 14-30 MPa; or from 14-25 MPa; or from 14-20 MPa; or from 14-18 MPa; or from 14-16 MPa; or from 17-35 MPa; or from 17-30 MPa; or from 17-25 MPa; or from 17-20 MPa; or from 17-18 MPa; or from 20-100 MPa; or from 20-90 MPa; or from 20-80 MPa; or from 20-75 MPa; or from 20-70 MPa; or from 20-65 MPa; or from 20-60 MPa; or from 20-55 MPa; or from 20-50 MPa; or from 20-45 MPa; or from 20-40 MPa; or from 20-35 MPa; or from 20-30 MPa; or from 20-25 MPa; or from 30-100 MPa; or from 30-90 MPa; or from 30-80 MPa; or from 30-75 MPa; or from 30-70 MPa; or from 30-65 MPa; or from 30-60 MPa; or from 30-55 MPa; or from 30-50 MPa; or from 30-45 MPa; or from 30-40 MPa; or from 30-35 MPa; or from 40-100 MPa; or from 40-90 MPa; or from 40-80 MPa; or from 40-75 MPa; or from 40-70 MPa; or from 40-65 MPa; or from 40-60 MPa; or from 40-55 MPa; or from 40-50 MPa; or from 40-45 MPa; or from 50-100 MPa; or from 50-90 MPa; or from 50-80 MPa; or from 50-75 MPa; or from 50-70

MPa; or from 50-65 MPa; or from 50-60 MPa; or from 50-55 MPa; or from 60-100 MPa; or from 60-90 MPa; or from 60-80 MPa; or from 60-75 MPa; or from 60-70 MPa; or from 60-65 MPa; or from 70-100 MPa; or from 70-90 MPa; or from 70-80 MPa; or from 70-75 MPa; or from 80-100 MPa; or from 80-90 MPa; or from 80-85 MPa; or from 90-100 MPa; or from 90-95 MPa; or 14 MPa; or 16 MPa; or 18 MPa; or 20 MPa; or 25 MPa; or 30 MPa; or 35 MPa; or 40 MPa; or 45 MPa. For example, in some embodiments of the foregoing aspects and the foregoing embodiments, the composition after setting, and hardening has a compressive strength of 14 MPa to 40 MPa; or 17 MPa to 40 MPa; or 20 MPa to 40 MPa; or 30 MPa to 40 MPa; or 35 MPa to 40 MPa. In some embodiments, the compressive strengths described herein are the compressive strengths after 1 day, or 3 days, or 7 days, or 28 days.

[0113] In some embodiments, electrochemical cells (e.g., a stack of electrochemical cells) may be operably connected to the above described processing system configured to precipitate a precipitation material comprising bicarbonates and/or carbonates (or a processed form thereof). Such carbonates and/or bicarbonates comprise calcium and/or magnesium. In some embodiments, the electrochemical cell or the stack of electrochemical cells may be operably connected to a system for further processing of the anolyte, which may comprise hydrochloric acid (if $\text{NaCl}(\text{aq})$ is used) or sulfuric acid (if $\text{Na}_2\text{SO}_4(\text{aq})$ is used). For example, in some embodiments, the electrochemical cell or the stack of electrochemical cells may be operably connected to a mineral-processing system comprising a mineral processor configured to dissolve minerals (e.g., mafic minerals such as olivine, serpentine, etc.) with the anolyte (e.g., hydrochloric acid and sodium chloride, sulfuric acid and sodium carbonate, etc.) and produce a solution comprising calcium and/or magnesium ions. In some embodiments, the anolyte may be used for other purposes in addition to, or instead of, mineral dissolution, including use as a reactant in production of cellulosic biofuels, use in the production of polyvinyl chloride (PVC), and the like. Systems appropriate for such uses may be operably connected to the stack of electrochemical cells, or the anolyte may be transported to an appropriate site for use.

EXAMPLE

Example 1

[0114] A solvay process is performed by absorbing carbon dioxide into ammonia solution in sodium chloride. The carbon dioxide is obtained from flue gas emitted by a power plant. The carbon dioxide gas is bubbled into the ammonia+sodium chloride solution. The carbon dioxide gas dissolves in the solution to form sodium bicarbonate and ammonium chloride is generated. Sodium bicarbonate is separated from the ammonium solution and is subjected to the electrochemical process for carbonate formation.

Example 2

[0115] This study demonstrates the savings in the voltage when an electrochemical cell was run with sodium hydroxide as catholyte vs. sodium bicarbonate as catholyte. A voltage sweep was performed in an electrochemical cell that was containing a 3-cell system (e.g., electrochemical cell of FIG. 16) with an anode and an anode electrolyte in an anode compartment, a cathode and a catholyte in a cathode com-

partment, and the anode compartment and the cathode compartment separated by an anion exchange membrane and a cation exchange membrane.

[0116] In one set of experiment, a voltage sweep was performed in the electrochemical cell where the anode was in contact with 0.5 wt % hydrochloric acid solution, the cathode was in contact with 10 wt % sodium hydroxide solution, and sodium chloride solution was in the middle chamber between ion exchange membranes. In another set of experiment, a voltage sweep was performed in the electrochemical cell that was containing anode in contact with 0.5 wt % hydrochloric acid solution, cathode in contact with 1 mol/L sodium bicarbonate solution (at pH 10), and sodium chloride solution was in the middle chamber between ion exchange membranes. The 1 mol/L sodium bicarbonate solution was formed by bubbling carbon dioxide in 1 mol sodium hydroxide solution that resulted in the formation of 1 mol/L sodium bicarbonate solution.

[0117] FIG. 19 illustrates that significant savings in the voltage were observed by introducing sodium bicarbonate into the catholyte (~250 mV) as compared to sodium hydroxide. The sodium hydroxide generated at the cathode converted bicarbonate to carbonate. The conversion of bicarbonate to carbonate depended on flow rates, current density and length of time.

[0118] While preferred embodiments have been shown and described herein, it will be obvious to those skilled in the art that such embodiments are provided by way of example only. Numerous variations, changes, and substitutions will now occur to those skilled in the art. It should be understood that various alternatives to the embodiments described herein may be employed without departing from spirit of this specification. It is intended that the following claims define the scope of the invention and that methods and structures within the scope of these claims and their equivalents be covered thereby.

What is claimed is:

1. A method to produce sodium carbonate, comprising:
 - a) absorbing carbon dioxide in an ammonia solution to form sodium bicarbonate; and
 - b) subjecting the sodium bicarbonate to a first electrochemical process to produce sodium carbonate.
2. A method to modify a Solvay process to produce a less carbon dioxide intensive Solvay process, comprising:
 - a) absorbing carbon dioxide in an ammonia solution to form sodium bicarbonate; and
 - b) subjecting the sodium bicarbonate to a first electrochemical process to produce sodium carbonate, thereby resulting in a less carbon dioxide intensive Solvay process.
3. The method of claim 1 or 2, further comprising regenerating the ammonia solution using calcium oxide obtained by lime calcination.

4. The method of claim 1 or 2, further comprising regenerating the ammonia solution using sodium hydroxide obtained from the first or a second electrochemical process.

5. The method of claim 1 or 2, wherein the method does not comprise bicarbonate calcination, lime calcination, or a combination thereof.

6. The method of claim 1 or 2, wherein the method produces less than 80% carbon dioxide as compared to a conventional Solvay process.

7. The method of claim 1 or 2, further comprising treating the sodium carbonate with calcium or magnesium ions to form calcium carbonate, magnesium carbonate, or combination thereof.

8. The method of claim 7, wherein the calcium carbonate, magnesium carbonate, or combination thereof is a cementitious material.

9. The method of claim 8, wherein the cementitious material comprises vaterite.

10. The method of claim 8, wherein the cementitious material has a compressive strength of greater than 10 MPa.

11. A system comprising a Solvay system integrated with an electrochemical system, comprising:

- a) a Solvay system comprising an absorber configured to absorb carbon dioxide in an ammonia solution to form sodium bicarbonate; and
- b) a first electrochemical system operably connected to the Solvay system configured to convert the sodium bicarbonate to sodium carbonate.

12. The system of claim 11, further comprising a regenerator operably connected to the Solvay system configured to regenerate the ammonia solution after absorption of the carbon dioxide in the ammonia solution.

13. The system of claim 12, further comprising a lime calciner operably connected to the regenerator and configured to produce calcium oxide for regenerating the ammonia solution.

14. The system of claim 12, further comprising a second electrochemical system operably connected to the regenerator and configured to produce sodium hydroxide for regenerating the ammonia solution.

15. The system of claim 11, further comprising a precipitator operably connected to the first electrochemical system configured to produce calcium and/or magnesium carbonate by treating sodium carbonate with calcium and/or magnesium ions.

* * * * *