



US 20120141052A1

(19) **United States**

(12) **Patent Application Publication**
Drew et al.

(10) **Pub. No.: US 2012/0141052 A1**

(43) **Pub. Date: Jun. 7, 2012**

(54) **SELF LUBRICATED BEARING
COMPOSITIONS AND METHODS OF
MAKING THE SAME**

Publication Classification

(51) **Int. Cl.**
F16C 33/10 (2006.01)
B21D 53/10 (2006.01)
(52) **U.S. Cl.** **384/13; 384/322; 29/898**

(75) Inventors: **Grant Drew**, Sanbornton, NH
(US); **Richard Soelch**, Sanbornton,
NH (US)

(57) **ABSTRACT**

(73) Assignee: **New Hampshire Ball Bearings,
Inc.**, Chatsworth, CA (US)

A self lubricated bearing contains a first member, a second member configured to slide against the first member, and a lubricating liner disposed in a sliding contact area between the first member and the second member. The lubricating liner contains at least one structural polymer and at least one lubricant with viscosity less than 5100 centistokes. A method is also provided for making the bearings, which includes adding the at least one lubricant with viscosity less than about 5100 centistokes to one or more components of the lubricating liner during the process of making the liner or bearing. The self lubricated bearing compositions of the invention have surprisingly long service lives versus prior art self lubricated bearings.

(21) Appl. No.: **13/287,251**

(22) Filed: **Nov. 2, 2011**

Related U.S. Application Data

(60) Provisional application No. 61/419,864, filed on Dec. 5, 2010.

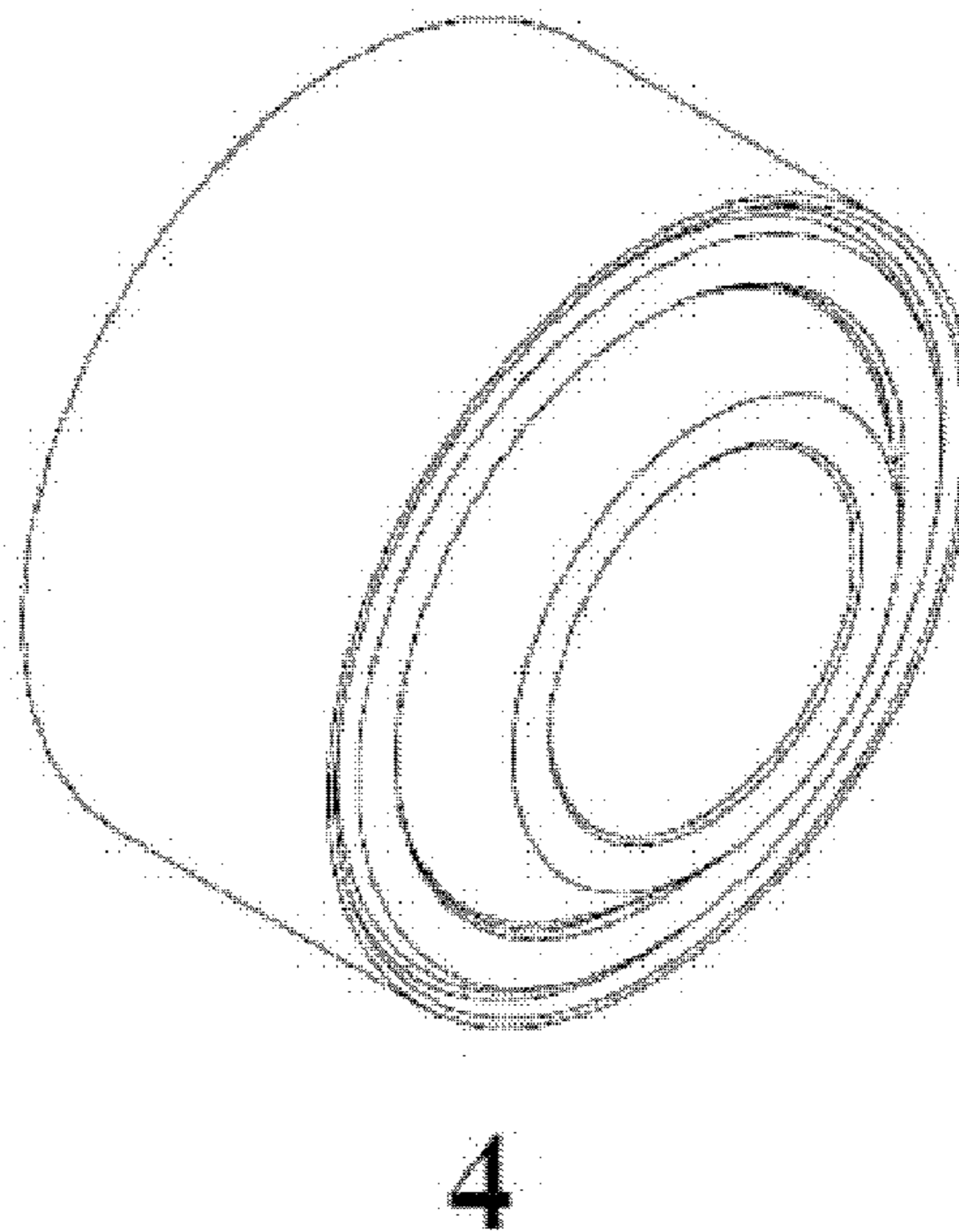
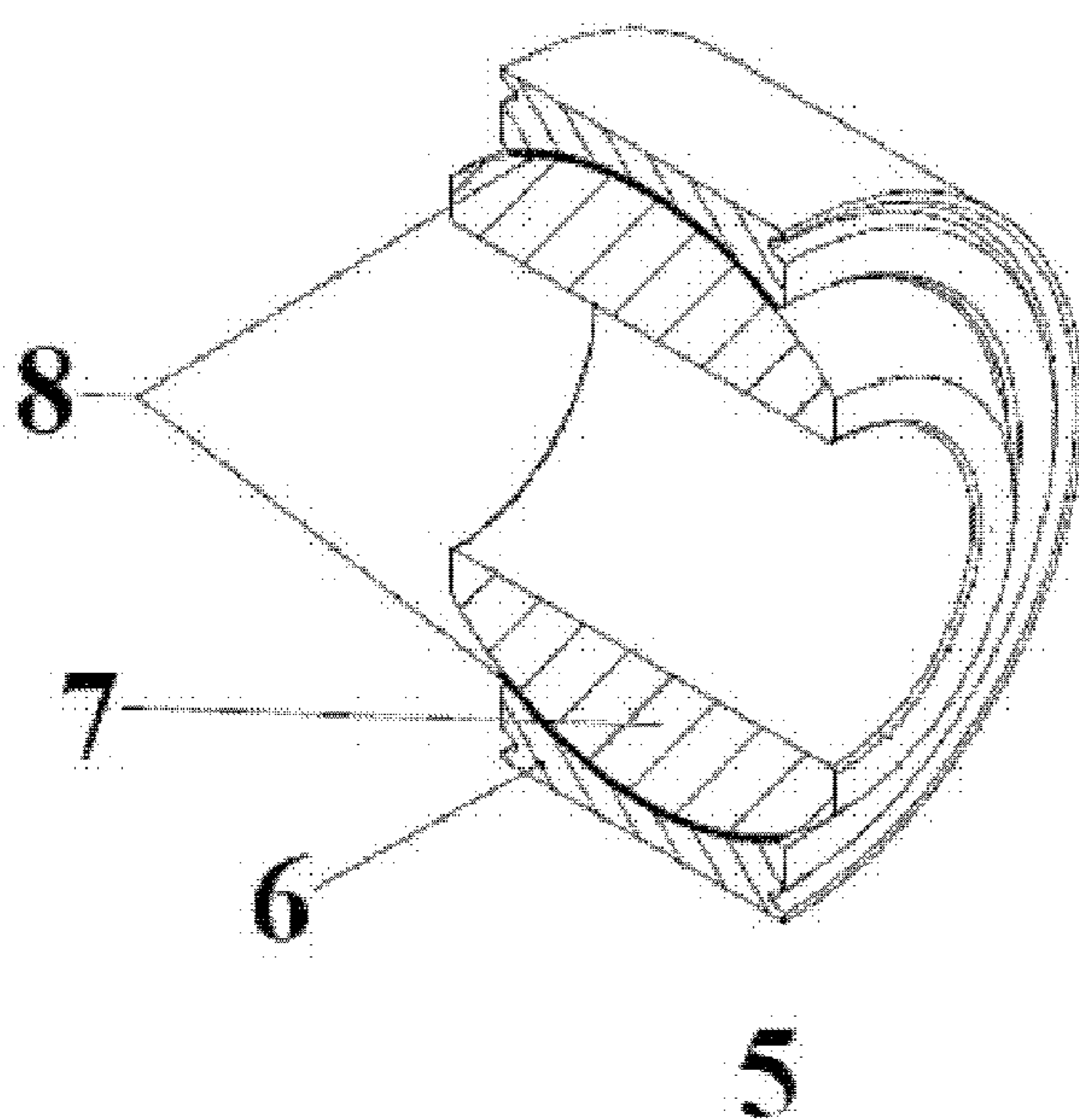

FIG. 1

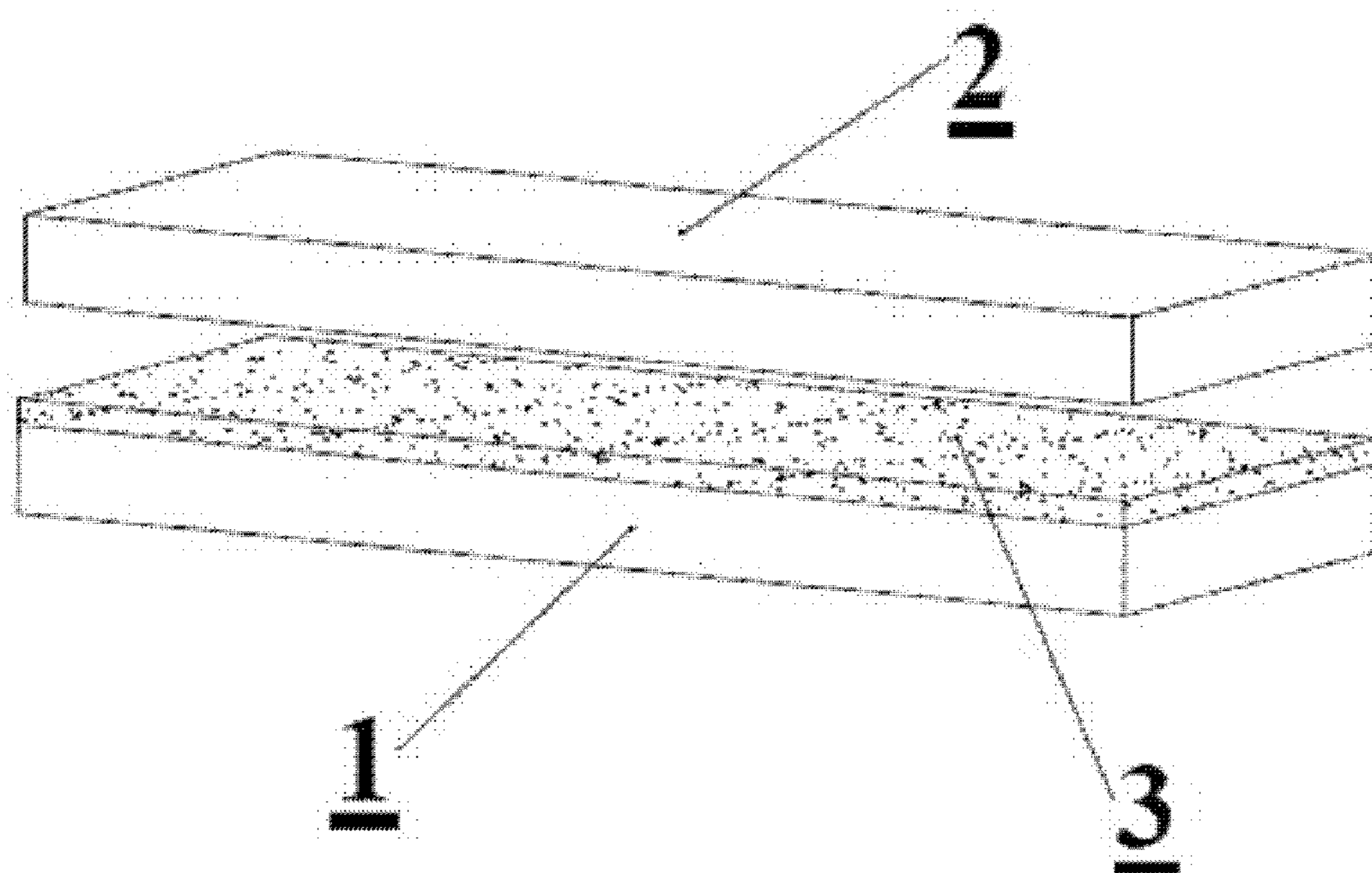

FIG. 2

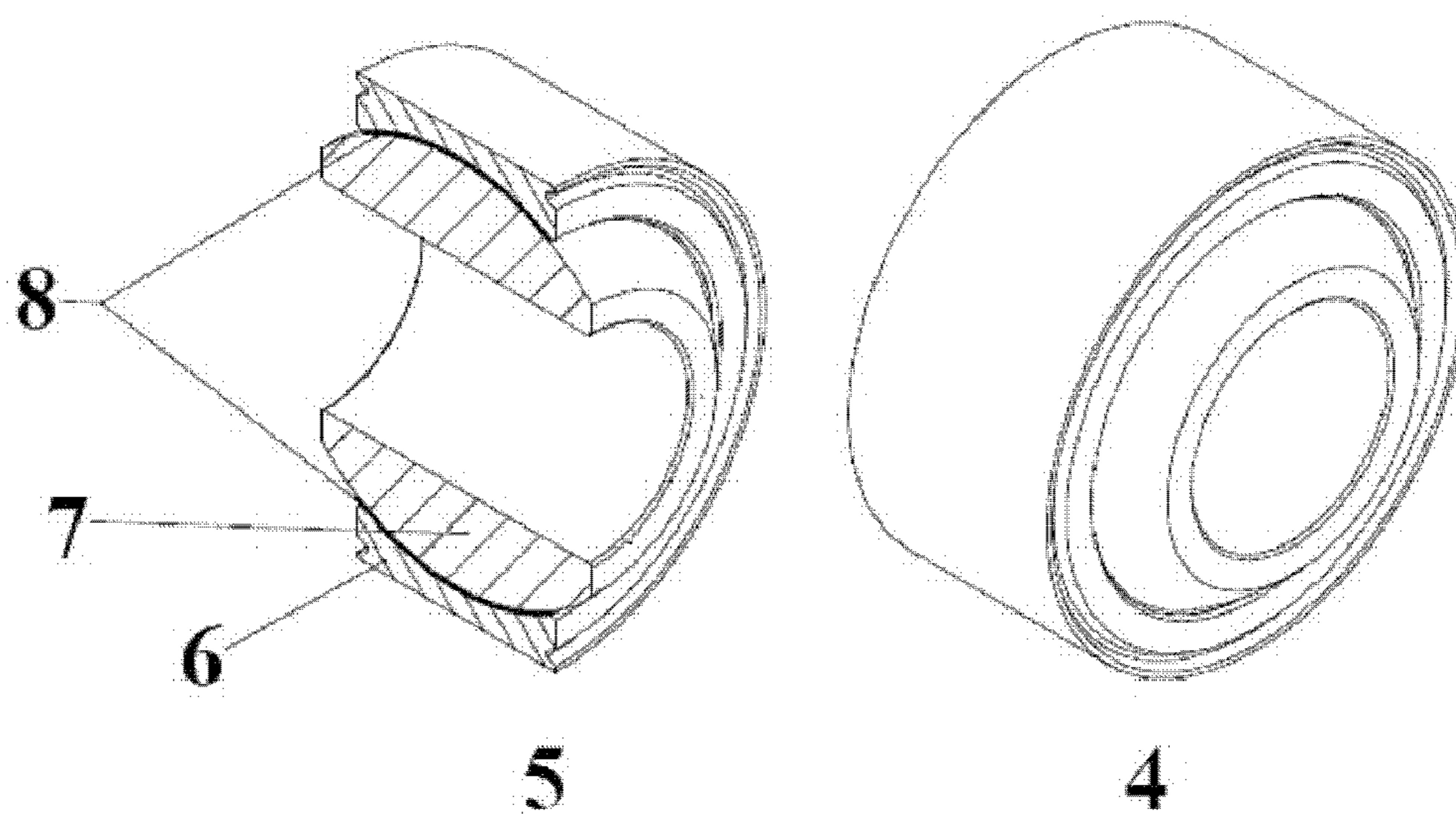

FIG. 3

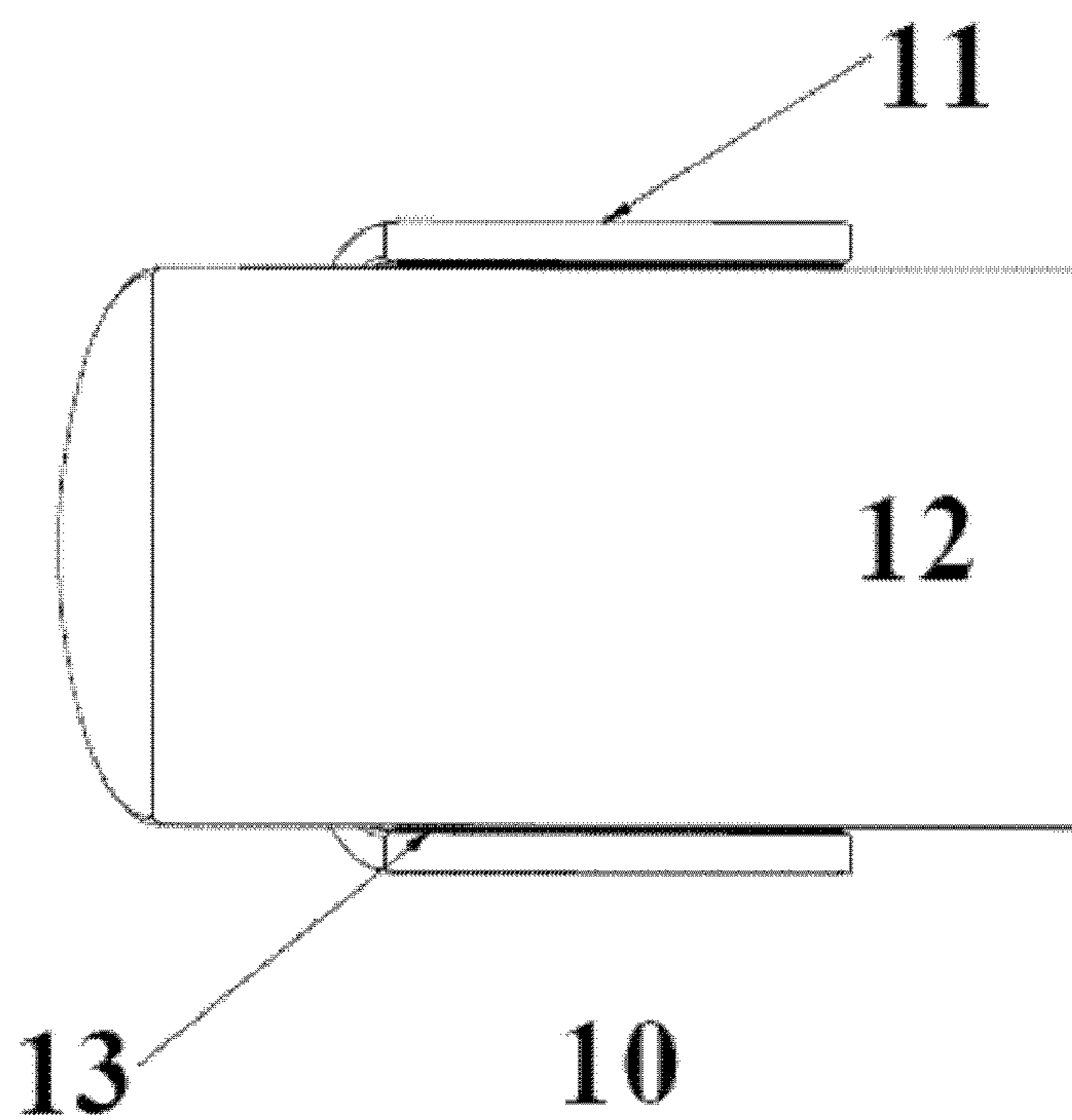
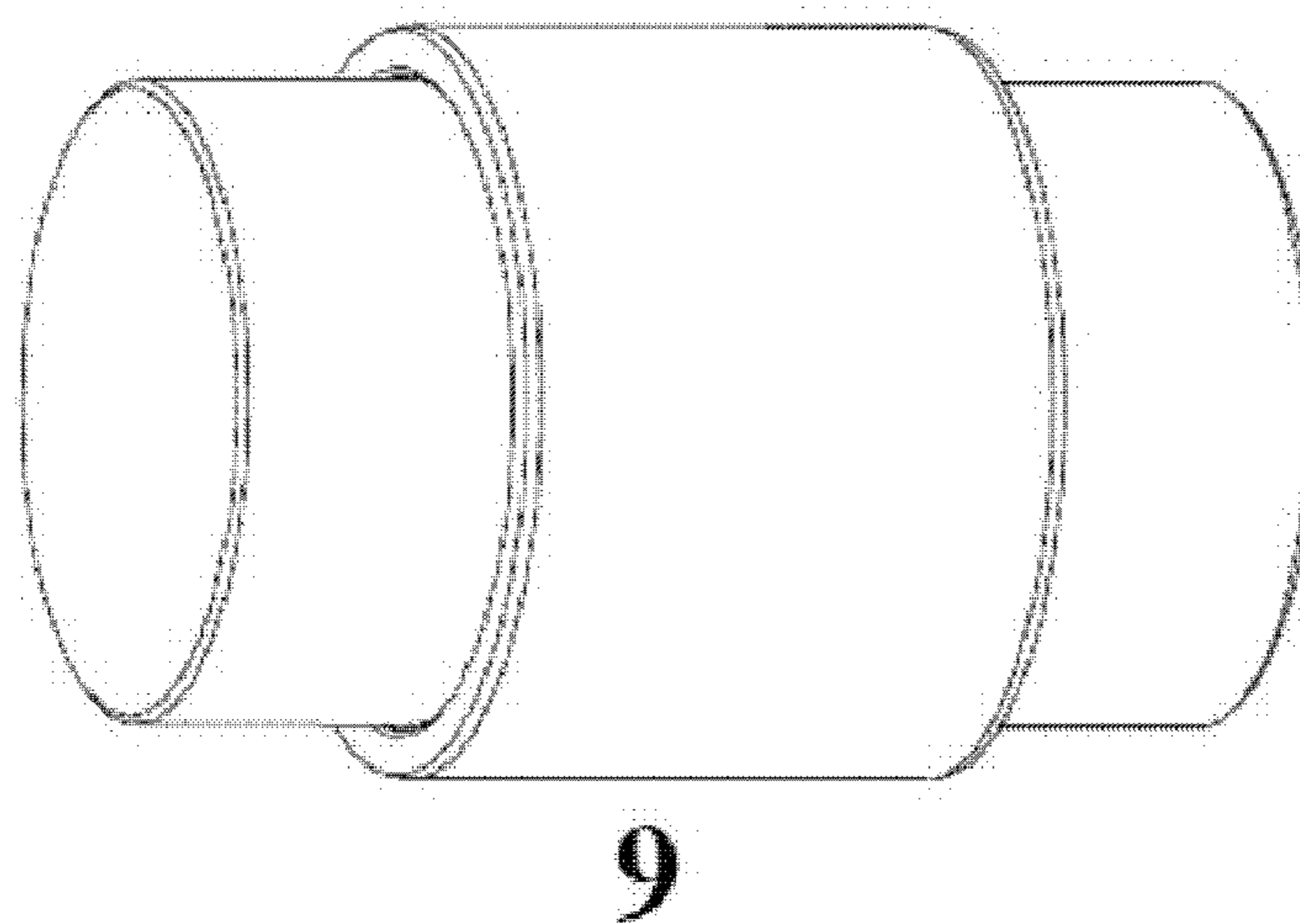

FIG. 4

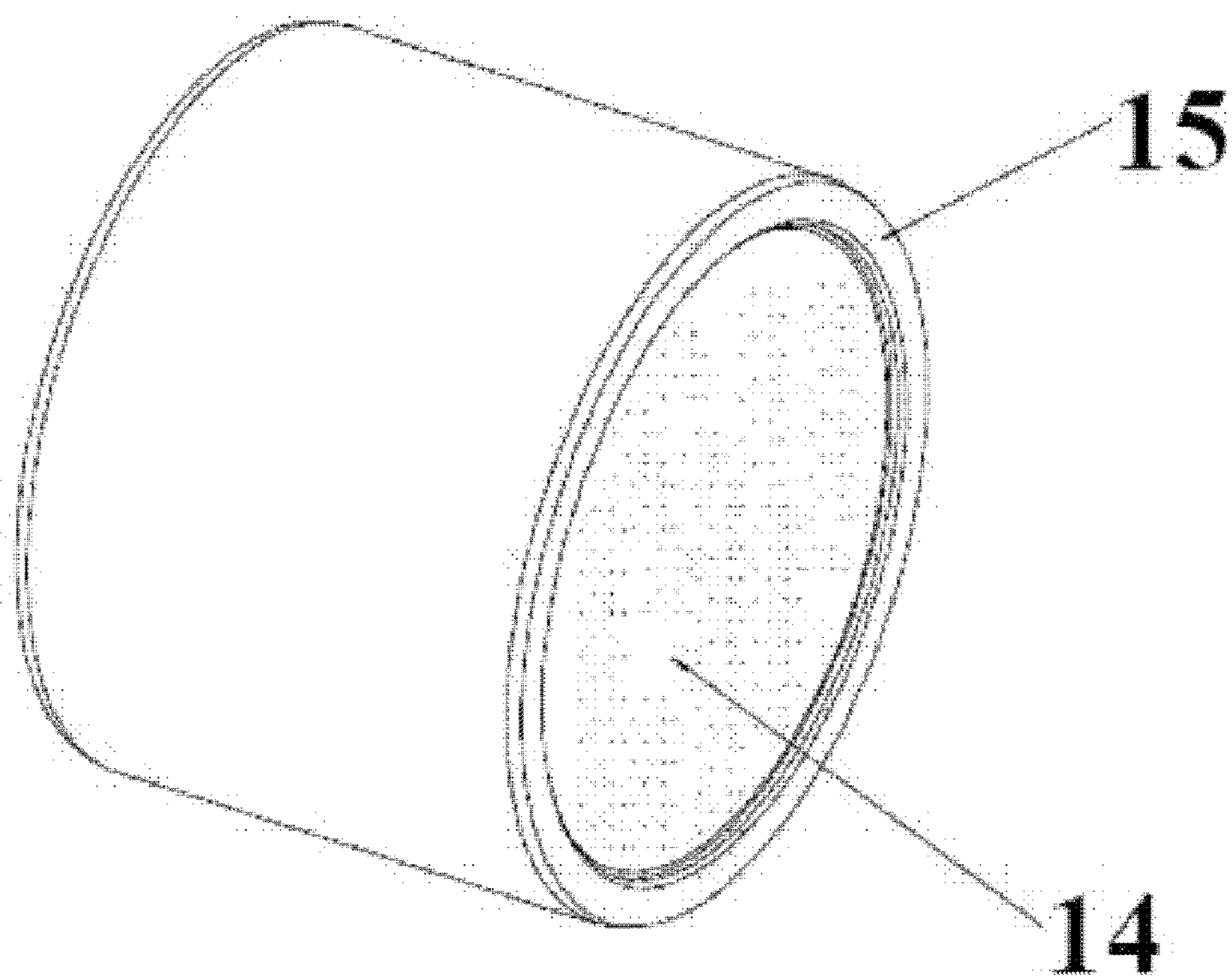

FIG. 5

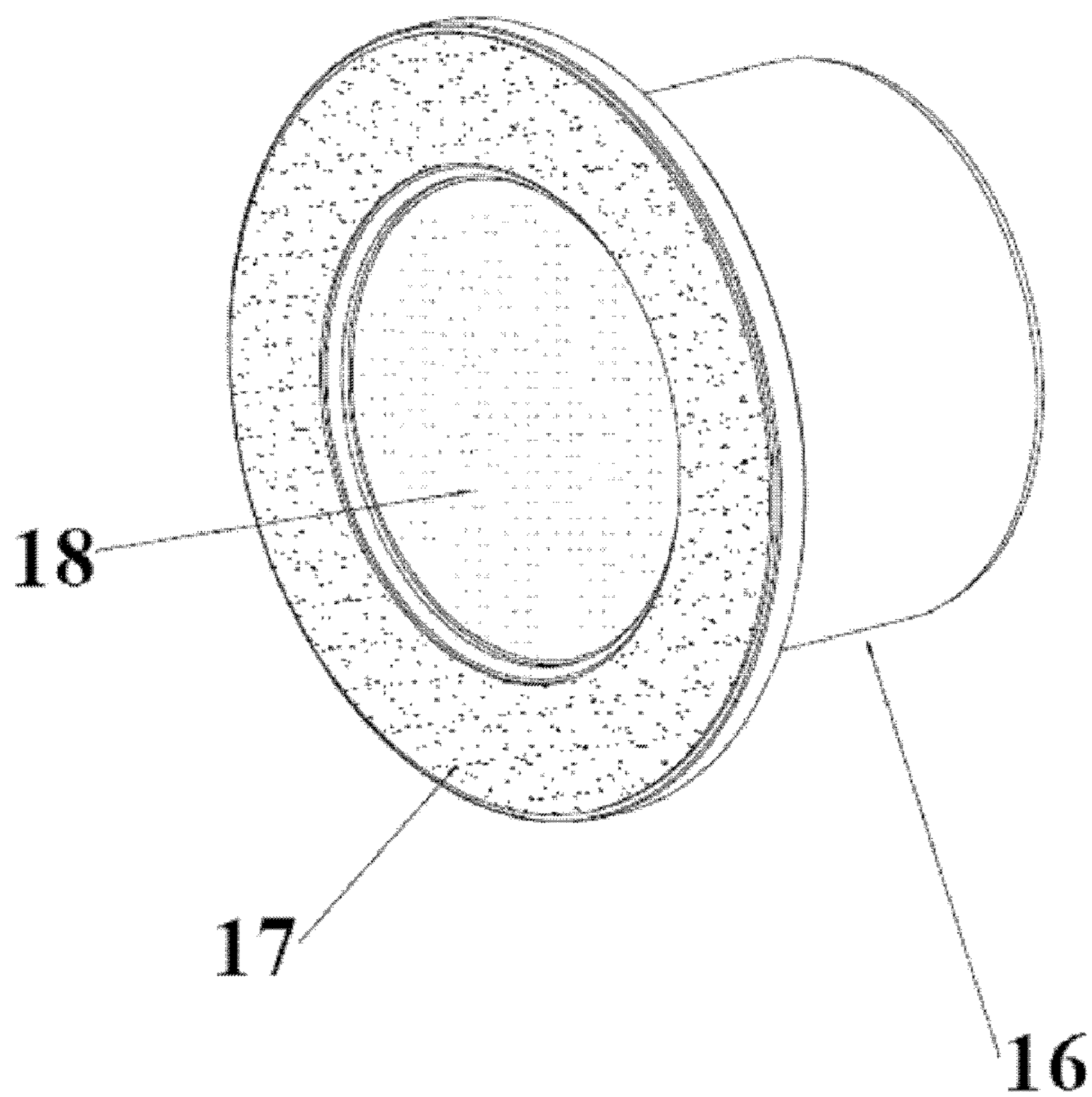
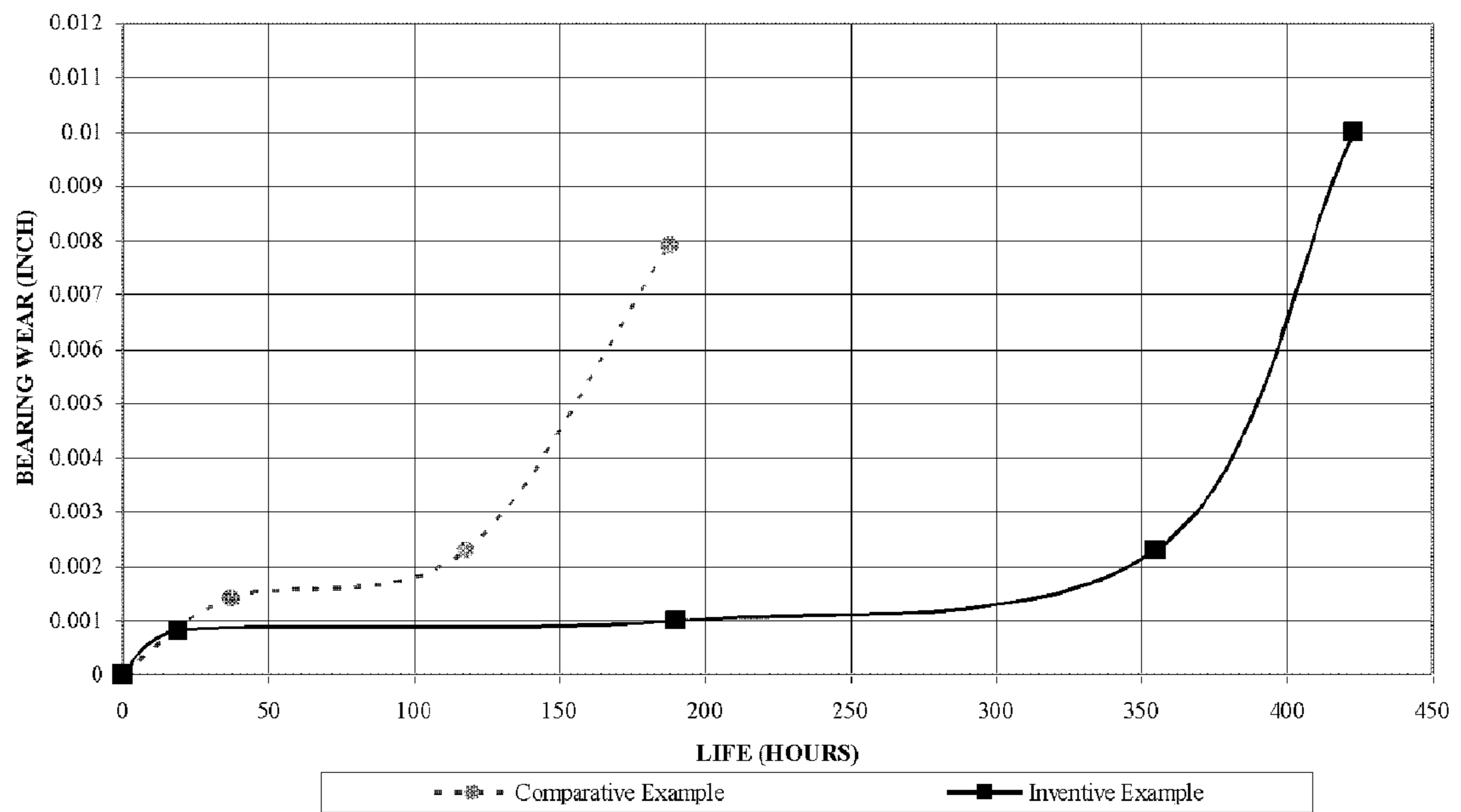

FIGURE 6

Inventive Example Has More Than Twice The Life of Comparative Example

(Mil-B-81819/1-2 Reversing Load Test with Alkaline Water PH 9-10)



**SELF LUBRICATED BEARING
COMPOSITIONS AND METHODS OF
MAKING THE SAME**

CROSS-REFERENCE TO RELATED
APPLICATION

[0001] This application claims priority to copending U.S. Provisional Application entitled, “SELF LUBRICATED BEARING COMPOSITIONS AND METHODS OF MAKING SAME,” having patent application Ser. No. 61/419,864, filed Dec. 5, 2010, which is entirely incorporated herein by reference.

FIELD OF THE INVENTION

[0002] The present invention relates to bearings, and particularly, to bearings having lubricating liners.

BACKGROUND OF THE INVENTION

[0003] Prior art bearings have attempted to provide an environment with decreased friction. Unfortunately, such attempts have failed in that they have a shortened service life, thereby having excess maintenance requirements and short bearing reliability. U.S. Pat. No. 3,932,008, by McCloskey and Williams, describes a spherical bearing including a bearing liner having a low friction layer containing a resin matrix which includes therein a dispersion of self lubricating particles including powdered or flock polytetrafluoroethylene (PTFE) particles and graphite fibers.

[0004] Self lubricated bearings using PTFE as a sliding surface have been in use in the aerospace industry since the 1960's according to U.S. Pat. No. 4,666,318, assigned to Ampep, pic. Thin films of woven PTFE bearing surfaces are frequently reinforced with sintered bronze and textile yarns such as glass, graphite fibers, or high strength organic yarns of relatively high melting point. Woven structures are usually infused with resin systems such as phenol formaldehyde, epoxies or cyanoacrylates to bind the sliding surface into a dense structure. The inventors go on to teach improved bearings using a reinforced low-friction plastic element containing PTFE having a sliding surface and a counter face with a low surface roughness and high hardness.

[0005] U.S. Pat. No. 6,180,574 assigned to Rexnord Corporation describes a self lubricating liner for bearings which includes a curable acrylate composition and a solid lubricant such as PTFE.

[0006] The abovementioned bearings, and other prior art bearings, have limited life. The prior art teaches bearings with self lubricating liners containing fluoropolymer solid lubricants. New self lubricated bearings are needed with improved service life to reduce maintenance requirements and cost as well as to increase the long term bearing reliability.

SUMMARY OF THE INVENTION

[0007] The present invention provides improved self lubricated bearing compositions containing a first member, a second member configured to slide against the first member, and a lubricating liner disposed in the sliding contact area between the first member and the second member, wherein the lubricating liner contains at least one structural polymer and at least one lubricant with a viscosity less than 5100 centistokes.

[0008] The bearing liner can be any bearing liner, including but not limited to, composite liners formed from combina-

tions of: woven and non-woven fabrics; binder resins; solid lubricants such as, but not limited to, polytetrafluoroethylene; and other additives. The bearing liner can also be a coated or molded liner made with: thermoplastic or thermoset resins; solid lubricants such as, but not limited to polytetrafluoroethylene; and other additives, reinforcements, stabilizers, catalysts, thixotropic agents, and colorants.

[0009] The present invention provides a way to substantially improve the performance of the prior art self lubricated bearings by addition of a lubricant having a viscosity less than 5100 centistokes in an amount of from 0.1% to 10% by weight of the total liner.

[0010] A method is also provided for making the bearings, where the method includes adding the at least one lubricant with viscosity less than 5100 centistokes to one or more components of the lubricating liner during the process of making the liner composition or bearing. A preferred method is provided whereby the at least one lubricant with viscosity below 5100 centistokes is vacuum impregnated into the self lubricating liner after the liner is adhered to one of the bearing members. The self lubricated bearings of the invention have surprisingly long service lives versus prior art self lubricated bearings.

BRIEF DESCRIPTION OF THE DRAWINGS

[0011] Many aspects of the invention can be better understood with reference to the following drawings. The components in the drawings are not necessarily to scale, emphasis instead being placed upon clearly illustrating the principles of the present invention. Moreover, in the drawings, like reference numerals designate corresponding parts throughout the several views.

[0012] FIG. 1 is an illustration of a bearing composition of the invention, wherein sliding members and a lubricating liner are depicted as flat surfaces.

[0013] FIG. 2 is a non-limiting illustration of a rotating bearing of the invention, specifically depicted is a self-aligning spherical bearing.

[0014] FIG. 3 is a non-limiting illustration of an additional type of bearing of the invention, specifically, a rod in a bushing.

[0015] FIG. 4 further illustrates the bushing with self lubricating liner of FIG. 3.

[0016] FIG. 5 illustrates a flanged bushing with lubricating liners on two surfaces. This bushing is a component with two bearing component surfaces—the outside flange and the internal circular bushing surface.

[0017] FIG. 6 is a wear versus use cycles graph for a spherical plain bearing Comparative Example versus a spherical plain bearing Inventive Example 1 containing a vacuum impregnated fluoropolymer lubricant with viscosity less than 5100 centistokes.

DETAILED DESCRIPTION OF THE PREFERRED
EMBODIMENT

[0018] The present invention provides improved self lubricated bearings containing a first member, a second member configured to slide against the first member, and a lubricating liner disposed in a sliding contact area between the first member and the second member. The self lubricating liner contains at least one structural polymer and at least one lubricant with a viscosity less than 5100 centistokes. In a preferred

bearing of the invention the at least one lubricant with a viscosity less than 5100 centistokes contains a fluorinated polymer.

[0019] A method is also provided for making the bearings, where the method includes adding the at least one lubricant with viscosity less than 5100 centistokes to one or more components of the lubricating liner during the process of making the liner or bearing. A preferred method is provided whereby the at least one lubricant with viscosity below 5100 centistokes is vacuum impregnated into the self lubricating liner after the liner is adhered to one of the bearing members. The self lubricated bearings of the invention have surprisingly long service lives versus prior art self lubricated bearings.

[0020] The self lubricated bearing is shown in FIG. 1. The illustration provided by FIG. 1 is meant to show the key elements of the invention and is by no means meant to limit the invention. The bearing contains a first member 1 (also referred to herein as a sliding member) configured to slide against a second member 2 (also referred to herein as a second sliding member) where a lubricating liner 3 is attached to first member 1 and located between the first member 1 and the second member 2. The illustration of FIG. 1 shows a space between the three components in order to illustrate that the lubricating liner 3 is attached to the first sliding member 1. In the bearing of FIG. 1, the second sliding member 2 is also in contact with the lubricating liner 3. The lubricating liner 3 moves with the first sliding member 1, to which it is attached, while the second sliding member 2 slides along the surface of the lubricating liner 3. The lubricating liner 3 may be attached to either one or the other sliding member 1, 2, however the lubricating liner 3 can also be floating freely between the members 1, 2 as long as other provisions are made to keep the lubricating liner 3 from moving out of the sliding contact area between the sliding members 1, 2. FIG. 1 depicts the sliding members 1, 2 as flat surfaces. It should be noted, however, that the sliding members 1, 2 can be any shape as long as they are in sliding contact with each other, via the lubricating liner 3.

[0021] FIG. 2 provides an illustration of one common type of self-lubricated bearing of the invention, specifically, a rotating bearing, 4. It should be noted that the bearing of FIG. 2 is intended to convey one type of object of the invention. These types of bearings can be found in many systems and actuators. A cross sectional view 5 of the rotating bearing 4 is also shown by FIG. 2. A ball 7 of the bearing has a convex outer surface (1st sliding member) in sliding contact with a self-lubricating liner 8, which is attached to a race component 6 (2nd sliding member). The particular ball type shown by FIG. 2 has a central bore so that it can be placed onto a shaft or rod and used in some construction. The self-lubricating liner 8 could also be attached to the ball 7; however this is usually not done in practice as a matter of convenience.

[0022] FIG. 3 is an illustration of a rod 12 in a bushing 11, which is another non-limiting example of a type of self-lubricated bearing 9 provided in accordance with the present invention. A cross sectional view 10 of the rod 12 in the bushing 11 is also shown in FIG. 3. The rod 12 is in sliding contact with a self-lubricating liner 13 (the very thin dark area between 11 and 12) disposed between the bushing 11 and the rod 12. The self lubricating liner 13 is adhered to the bushing 11. The self-lubricating liner 13 contains a structural polymer and at least one lubricant with viscosity below 5100 centistokes.

[0023] FIG. 4 illustrates a bushing or one sliding member 15 having the thin liner 14 attached to the inner surface of the

sliding member 15. The other sliding surface is not shown in this rendering. The liner 14 is attached to the inner surface of the bushing 15, but could also be attached to the outer surface of the bushing 15 in the case where the other sliding component was a sleeve.

[0024] FIG. 5 illustrates a flanged bushing 16 with lubricating liners 17, 18 on two surfaces. This bushing is a component with two bearing component surfaces—the outside flange and the internal circular bushing surface. The mating sliding surfaces are not shown in this figure.

[0025] FIG. 6 is a bearing wear versus life graph illustrating a prior art self-lubricated bearing and a bearing of the invention which is identical to the prior art bearing except that a fluoropolymer lubricant with viscosity less than 5100 centistokes was vacuum impregnated into the self lubricating liner. These bearings were tested according to Mil-B-81819/1-2 (Reversing Load Test with Alkaline Water Contaminant) which is used to evaluate helicopter bearings. The Comparative Example self lubricated bearing of the invention is commercially available and the Inventive Example 1 bearing is the same bearing as the Comparative example bearing except that a fluoropolymer lubricant with viscosity below 5100 centistokes was vacuum impregnated into it. Inventive Example 1 bearings had less than half the wear after 1600 hours of testing under MILB-81819/1 Test Condition 4. This is a surprising result because the Comparative Example Bearings already contain a fluoropolymer lubricant; however the fluoropolymer lubricant incorporated into Comparative Example 1 bearing has viscosity greater than 5100 centistokes. In one embodiment this invention can be used to greatly extend the maintenance intervals for helicopters, thereby reducing operating costs, since it provides superior bearing life.

[0026] It should be emphasized that the above-described embodiments of the present invention, particularly, any “preferred” embodiments, are merely possible examples of implementations, merely set forth for a clear understanding of the principles of the invention. Many variations and modifications may be made to the above-described embodiment(s) of the invention without departing substantially from the spirit and principles of the invention. All such modifications and variations are intended to be included herein within the scope of this disclosure and the present invention and protected by the following claims.

Self Lubricated Bearing Description

[0027] The principal self lubricated bearing components of the invention are illustrated in FIG. 1. The first and second members may be constructed of any materials, and may be the same or different. As an example, the first and second members may be metal, polymer or ceramic based compositions or a combination of one or more of these compositions. In cases where the first or second members are some combination of metal and polymer, metal and ceramic, polymer and ceramic, or metal, polymer, and ceramic, the combination can be in the form of a composite structure where one or more components are intimately mixed with the other component or they may be in a layered structure where one or more components are layered on top of the other component (one non-limiting example being a ceramic coating over a metal substrate).

[0028] Often the first member is made of different materials than the second member in order to optimize bearing performance and reduce wear of the member as it slides along the lubricated liner. The first and second members often have specific surface finishes that may be the same or different. The

first member may have a rougher surface finish to enhance adhesion of the lubricating liner in cases where the lubricating liner is adhered to the first member. In other articles of the invention the first and or second members may have a highly polished surface to reduce abrasive wear between the member and the lubricating liner.

[0029] The lubricating liner contains at least one structural polymer and at least one lubricant with viscosity less than 5100 centistokes. The structural polymer useful in the invention may be any thermoplastic or thermoset polymer. The structural polymer may be a homopolymer or copolymer. The structural polymer can be a mixture or alloy of two or more polymers.

[0030] A list of applicable structural polymer types (homo- or co-polymers) and thermoset polymers includes, but is not limited to: phenolic; epoxy; acrylate; polyester; polyamide; polyaramide; liquid crystal polymers; polyimides; polyamideimide; polyetherketone; polyether ether ketone (PEEK); polyphenylene oxide; polycarbonate; polyphenylene sulfide; polyethylene; polypropylene; polyoxymethylene; polybenzimidazole; and polyphenylene, among others.

[0031] The structural polymers may contain any organic or inorganic additives, reinforcements, fibers, woven fabrics, non-woven fabrics, or stabilizers, to provide strength, toughness, stiffness, heat resistance, thermal conductivity, dimensional stability, hardness, wear resistance, thixotropy, color, or other attributes. The structural polymers provide the matrix for the lubricating liner composition.

[0032] The lubricating liner compositions useful in the invention may also contain reinforcing fibers. Glass fibers, polyaramide fibers, and carbon fibers are some of the more common reinforcing fibers found in self lubricated bearing liners. One or more solid lubricant particles, organic fibers, or inorganic fibers especially comprised of polytetrafluoroethylene or other lubricants such as graphite, molybdenum disulfide, and hexagonal boron nitride are often included in the lubricating liner compositions useful in the invention.

[0033] The lubricating liner useful in the present invention may be solid or may have porosity. The porosity may have a closed cell (isolated pores) or open cell (connected pores) structure. Cured phenolic resins often naturally have some porosity within their cured structure. The lubricating liner may have porosity engineered into the composition through the use of foaming agents.

[0034] The lubricating liner can also have porosity engineered into its structure through the use of extractible salts. One non-limiting example would be using sodium benzoate as an additive to a polymer liner composition. The sodium benzoate may be subsequently extracted with hot water after the liner is formed, thereby leaving an engineered reservoir. This engineered reservoir is then vacuum impregnated or otherwise filled with at least one lubricant with viscosity below 5100 est.

[0035] The structural polymer holds the liner composition together and gives it integrity. The structural polymer may also contain a woven or non-woven fabric of any composition to provide increased strength or lubricity (in the case where the fabric comprises polytetrafluoroethylene, polyethylene fibers, or other lubricating fibers).

[0036] The lubricating liner may also contain solid lubricant polytetrafluoroethylene film in a composite type of structure.

[0037] The self lubricated bearings can be made by separately making the lubricating liner, adhering it to one of the

sliding members, and then constructing the bearing. The lubricating liner can also be made directly between the sliding members by a molding process where the liner composition is injected between the members and hardened in place. The lubricating liner can also be coated onto one of the sliding members and then combined with the other sliding member. The lubricating liner can also be placed between the sliding members and not adhered to one or the other sliding member so long as provision is made to mechanically or otherwise prevent the lubricating liner from slipping or moving out from in between the sliding members.

[0038] The at least one lubricant with viscosity less than about 5100 centistokes (cst) can be any lubricant such as silicone fluids, hydrocarbon fluids, synthetic fluids, low molecular weight fluoropolymers or mixtures of more than one of these. The at least one lubricant viscosity is measured at or below 100° C. where it is less than about 5100 centistokes. The at least one lubricant can also contain dispersed additives to further enhance performance such as antioxidants, stabilizers, anti-corrosion additives, or fine lubricant particles like polytetrafluoroethylene, ceramic, graphite, molybdenum disulfide or hexagonal boron nitride. The at least one lubricant is preferably a perfluoropolyether, which represents a class of perfluoropolymers that differ mostly in viscosity (molecular weight) and chemical functionality. Some examples of commercially available perfluoropolyethers useful in the present invention include, but are not limited to, Krytox® GPL 100 series and XP series containing anticorrosion additives available from the DuPont Company. The at least one lubricant can also be chemically functionalized to enhance compatibility with the structural polymer, if so desired. An example of a chemically functionalized perfluoropolyether would be Fluorogard FMS from the DuPont Company. Perfluoropolyethers are also available from other manufacturers such as Solvay Solexis.

[0039] The at least one lubricant with viscosity below about 5100 cst can be added to the self lubricating liner at any stage of manufacture of the bearing of the invention. The at least one lubricant with viscosity below about 5100 cst can be added to one or more of the liner components before the liner is formed, molded, or otherwise assembled. The at least one lubricant with viscosity below about 5100 cst can be added to the liner after it is formed and can be added to the liner before or after the liner is assembled with the first bearing member and the second bearing member. In bearings of the invention where the liner is molded, sprayed, or otherwise coated in place, such as with acrylate liners or epoxy liners, for example, the at least one lubricant with viscosity below about 5100 cst can optionally be combined with the acrylate liner precursors or epoxy liner precursors before molding, spraying, or otherwise coating the liner into place.

[0040] In a preferred method, the at least one lubricant with viscosity below about 5100 cst is added to the liner after the liner is adhered to one of the bearing members. In the most preferred method the at least one lubricant with viscosity below about 5100 cst is vacuum impregnated into the liner after the liner is adhered to one of the bearing members.

Therefore, having thus described the invention, at least the following is claimed:

1. A self lubricated bearing, comprising:
 - a first member;
 - a second member configured to slide against the first member; and

- a lubricating liner disposed between the first member and the second member where the lubricating liner comprises at least one structural polymer and at least one lubricant with a viscosity less than 5100 centistokes.
- 2.** The self lubricated bearing of claim **1**, wherein the at least one lubricant with viscosity below 5100 centistokes is a fluorinated polymer.
- 3.** The self lubricated bearing of claim **1**, wherein the at least one lubricant has a viscosity less than 2000 centistokes.
- 4.** The self lubricated bearing of claim **1**, wherein the at least one lubricant is a perfluoropolyether with a viscosity less than 5100 centistokes.
- 5.** The self lubricated bearing of claim **1**, wherein the lubricating liner comprises at least one structural polymer and 0.1%-15% by weight of one lubricant with a viscosity less than 5100 centistokes.
- 6.** The self lubricated bearing of claim **1**, wherein the at least one structural polymer is a phenolic resin.
- 7.** The self lubricated bearing of claim **1**, wherein the at least one structural polymer is an epoxy resin.
- 8.** The self lubricated bearing of claim **1**, wherein the at least one structural polymer is a polyimide resin.
- 9.** The self lubricated bearing of claim **1**, wherein the at least one structural polymer is an acrylate resin.
- 10.** The self lubricated bearing of claim **1**, wherein the lubricating liner additionally comprises a fibrous reinforcement.
- 11.** The self lubricated bearing of claim **1**, wherein the bearing is a ball bearing.
- 12.** The self lubricated bearing of claim **1**, wherein the bearing is a bushing.
- 13.** The self lubricated bearing of claim **1**, wherein the sliding area between the sliding members is essentially a flat surface.
- 14.** A method to make a self lubricated bearing comprising a first member; a second member configured to slide against the first member; a lubricating liner disposed between the first member and the second member where the lubricating liner comprises at least one structural polymer and at least one lubricant with a viscosity less than 5100 centistokes wherein the at least one lubricant with a viscosity less than 5100 centistokes is vacuum impregnated into the lubricating liner after the lubricating liner is adhered to either the first member or the second member.
- 15.** The method of claim **14** wherein the at least one lubricant is a perfluoropolyether.
- 16.** The method of claim **14** wherein the at least one lubricant is a hydrocarbon lubricant.
- 17.** The method of claim **14** wherein the at least one lubricant is a silicone lubricant.
- 18.** The method of claim **14** wherein the at least one lubricant is a fluorinated polymer with a viscosity less than 2000 centistokes.
- 19.** The method of claim **14** wherein the at least one lubricant is a perfluoropolyether with a viscosity less than 2000 centistokes.
- 20.** The method of claim **14** wherein the lubricating liner comprises at least one structural polymer and 0.1%-15% by weight of at least one lubricant wherein the lubricant is a fluorinated polymer with a viscosity less than 5100 centistokes.
- 21.** The method of claim **14** wherein the lubricating liner comprises at least one structural polymer and 0.1%-15% by weight of at least one lubricant wherein the lubricant is a fluorinated polymer with a viscosity less than 2000 centistokes.
- 22.** The method of claim **14** wherein the lubricating liner comprises at least one structural polymer and 0.1%-15% by weight of at least one lubricant wherein the lubricant is a perfluoropolyether with a viscosity less than 2000 centistokes.
- 23.** The method of claim **14** wherein the at least one structural polymer is a phenolic resin.
- 24.** The method of claim **14** wherein the at least one structural polymer is an epoxy resin.
- 25.** The method of claim **14** wherein the at least one structural polymer is a polyimide resin.
- 26.** The method of claim **14** wherein the at least one structural polymer is a cured acrylate resin.
- 27.** The method of claim **14** wherein the lubricating liner additionally comprises a fibrous reinforcement.
- 28.** A self lubricated helicopter bearing comprising:
a first member;
a second member configured to slide against the first member; and
a lubricating liner disposed between the first member and the second member where the lubricating liner comprises at least one structural polymer and at least one lubricant with a viscosity less than 5100 centistokes.
- 29.** The self lubricated helicopter bearing of claim **28**, wherein the bearing is a helicopter main rotor bearing.
- 30.** The self lubricated helicopter bearing of claim **28**, wherein the bearing is a helicopter tail rotor bearing.

* * * * *