

US 20120006369A1

(19) **United States**

(12) **Patent Application Publication**  
**CANTIN et al.**

(10) **Pub. No.: US 2012/0006369 A1**

(43) **Pub. Date: Jan. 12, 2012**

(54) **EXPANDABLE ISO SHELTERS**

**Publication Classification**

(75) Inventors: **Philip T. CANTIN**, Guildhall, VT (US); **Rick A. Cochran**, St. Johnsbury, VT (US); **Justin M. WHITE**, West Danville, VT (US)

(51) **Int. Cl.**  
**E04H 15/48** (2006.01)  
**E04H 15/02** (2006.01)

(52) **U.S. Cl.** ..... **135/96; 135/143**

(73) Assignee: **MOBILE MEDICAL INTERNATIONAL CORPORATION**, St. Johnsbury, VT (US)

(57) **ABSTRACT**

(21) Appl. No.: **13/168,702**

An expandable shelter having an expanded configuration and a collapsed configuration in which the shelter has the approximate dimensions of a standard International Organization for Standardization (ISO) freight container. The expandable shelter includes first and second substantially parallel corner posts disposed at a first end of the shelter. The expandable shelter also includes a ramp coupled with hinges at the first end of the shelter and is configured to fit securely on the interior of the first and second corner posts when in a closed configuration in which the ramp is disposed between the first and second corner posts. The expandable shelter has sufficient strength to withstand the forces of at least eight similar shelters stacked on top of the shelter.

(22) Filed: **Jun. 24, 2011**

**Related U.S. Application Data**

(60) Provisional application No. 61/358,120, filed on Jun. 24, 2010.

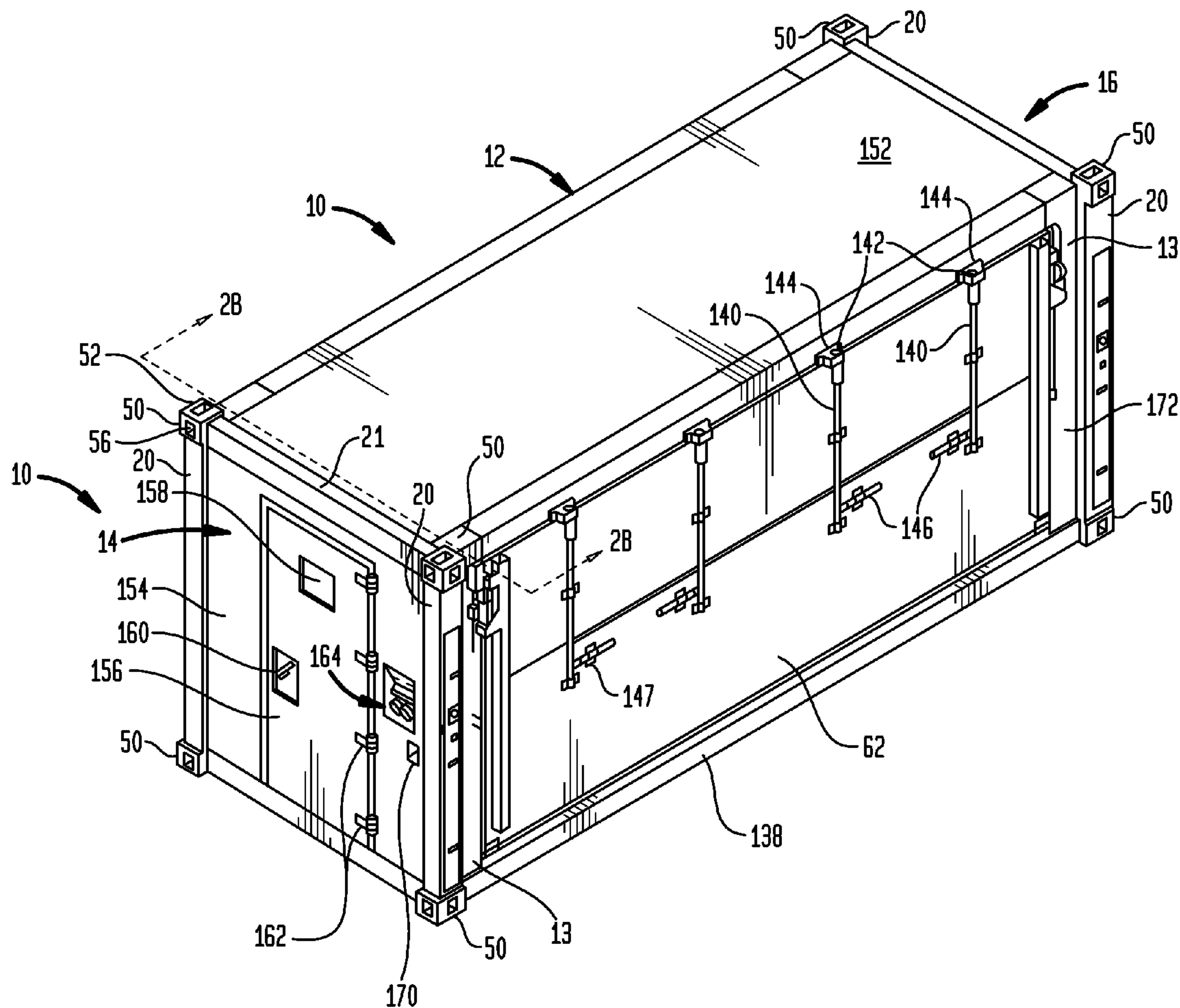

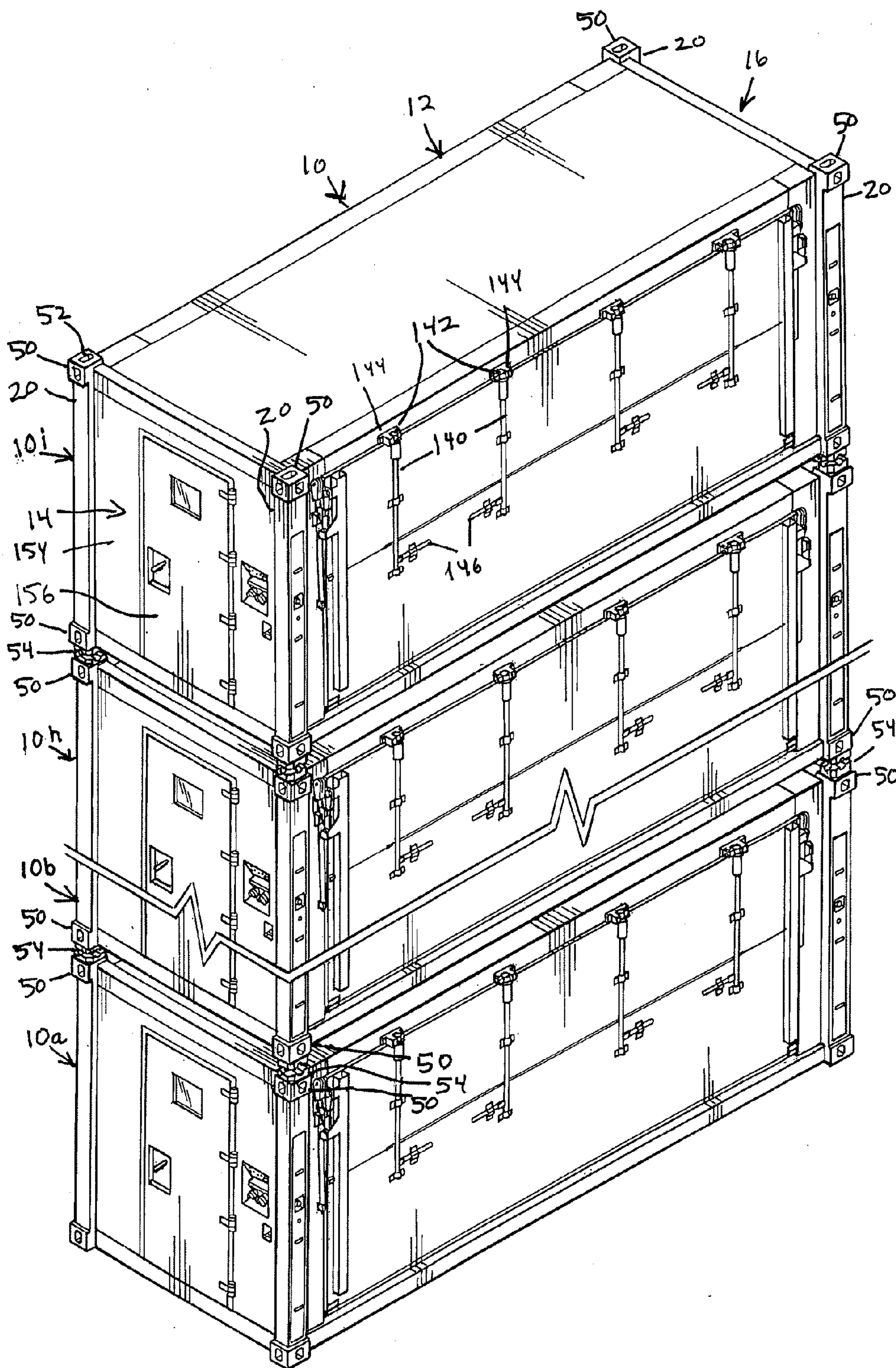

Fig. 1



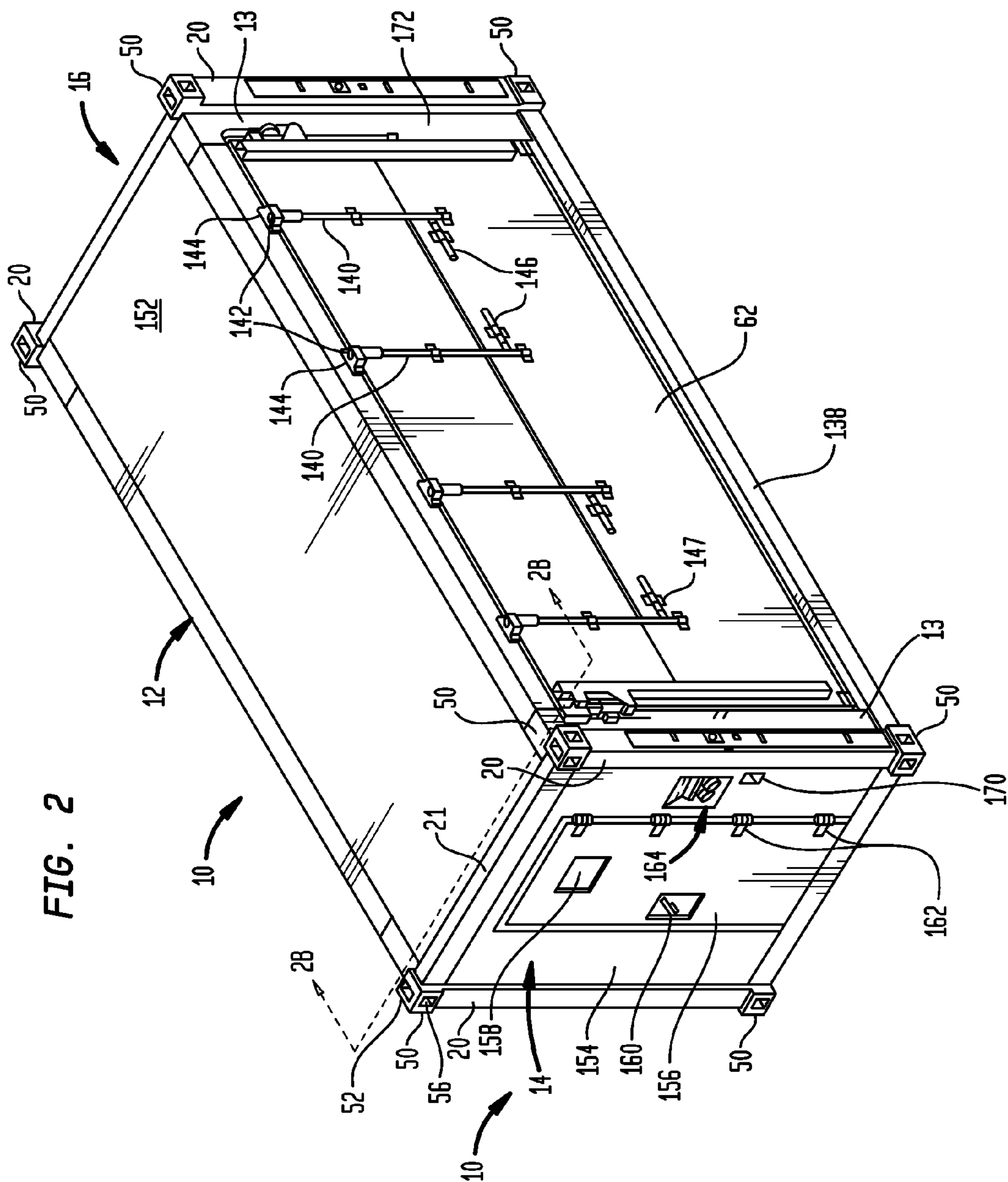
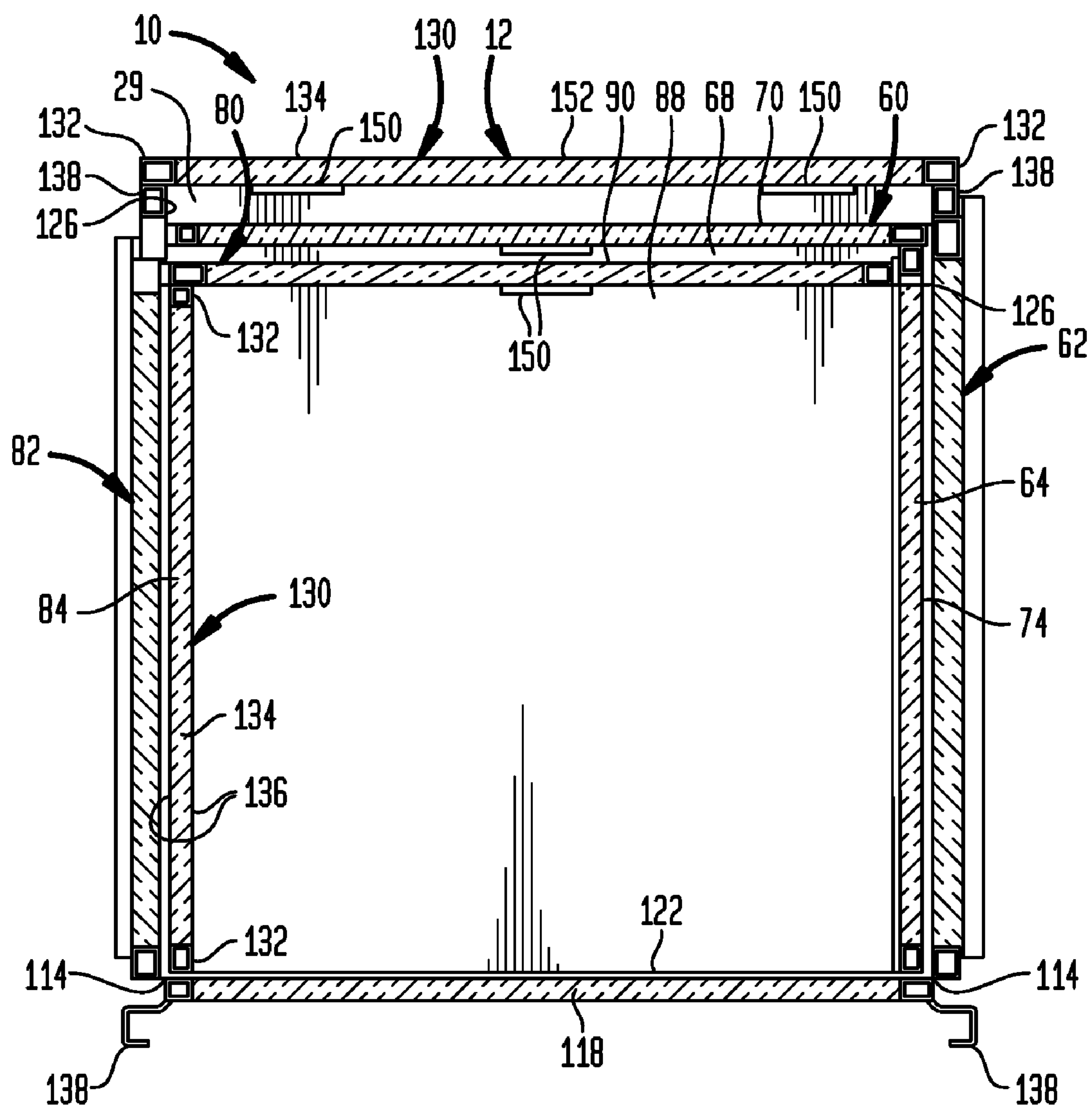
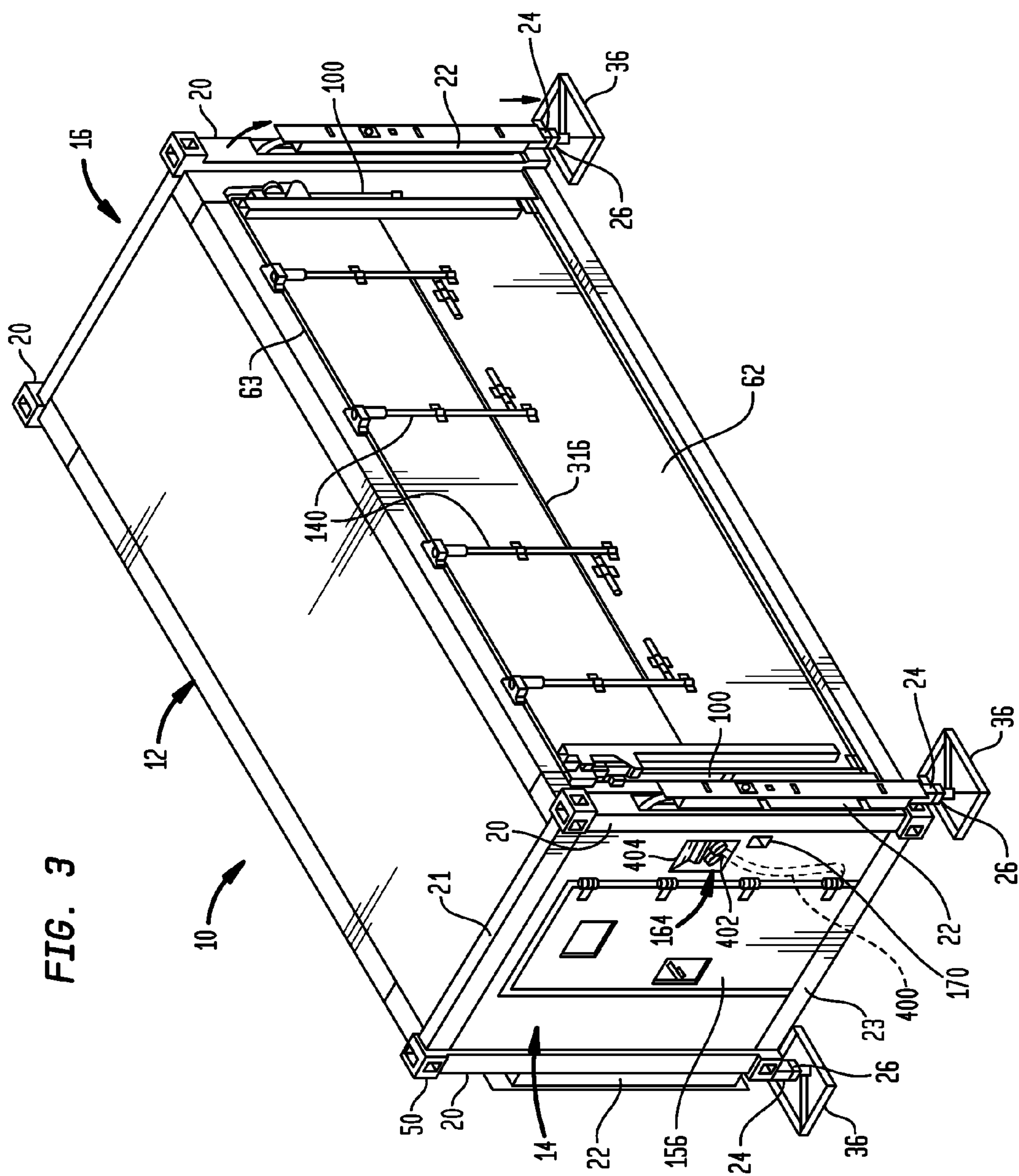

FIG. 2A





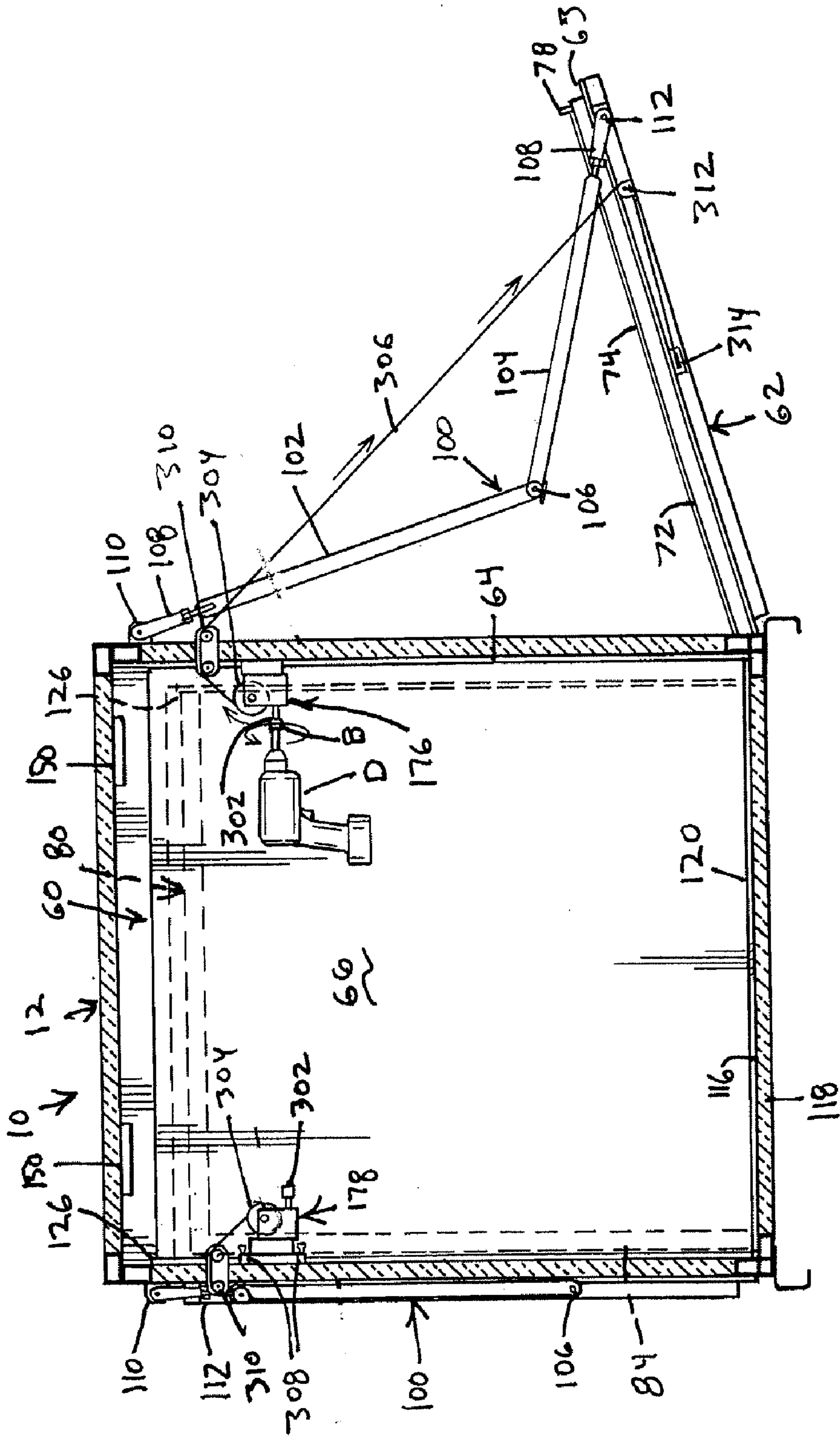

Fig. 3A



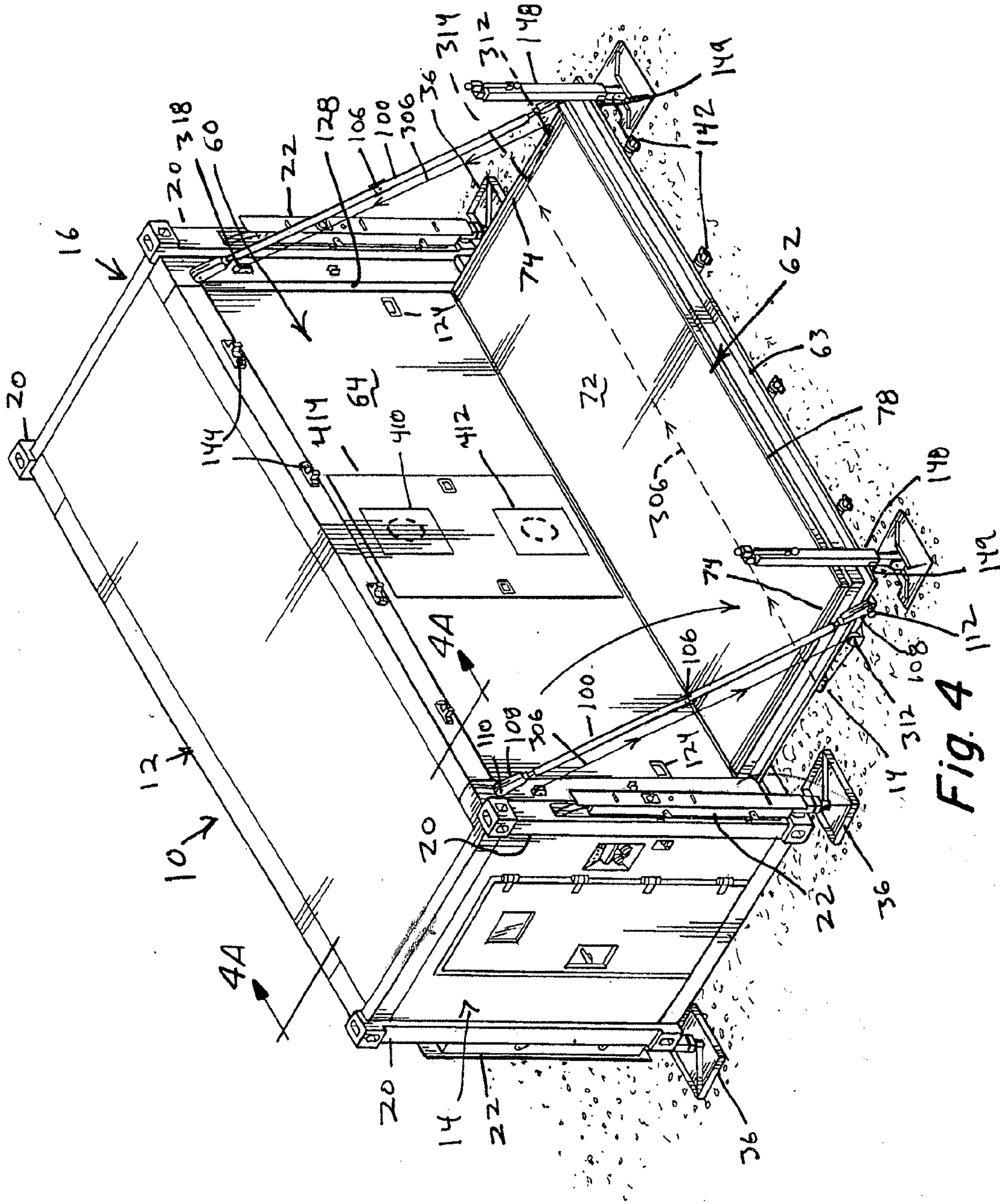

Fig. 4





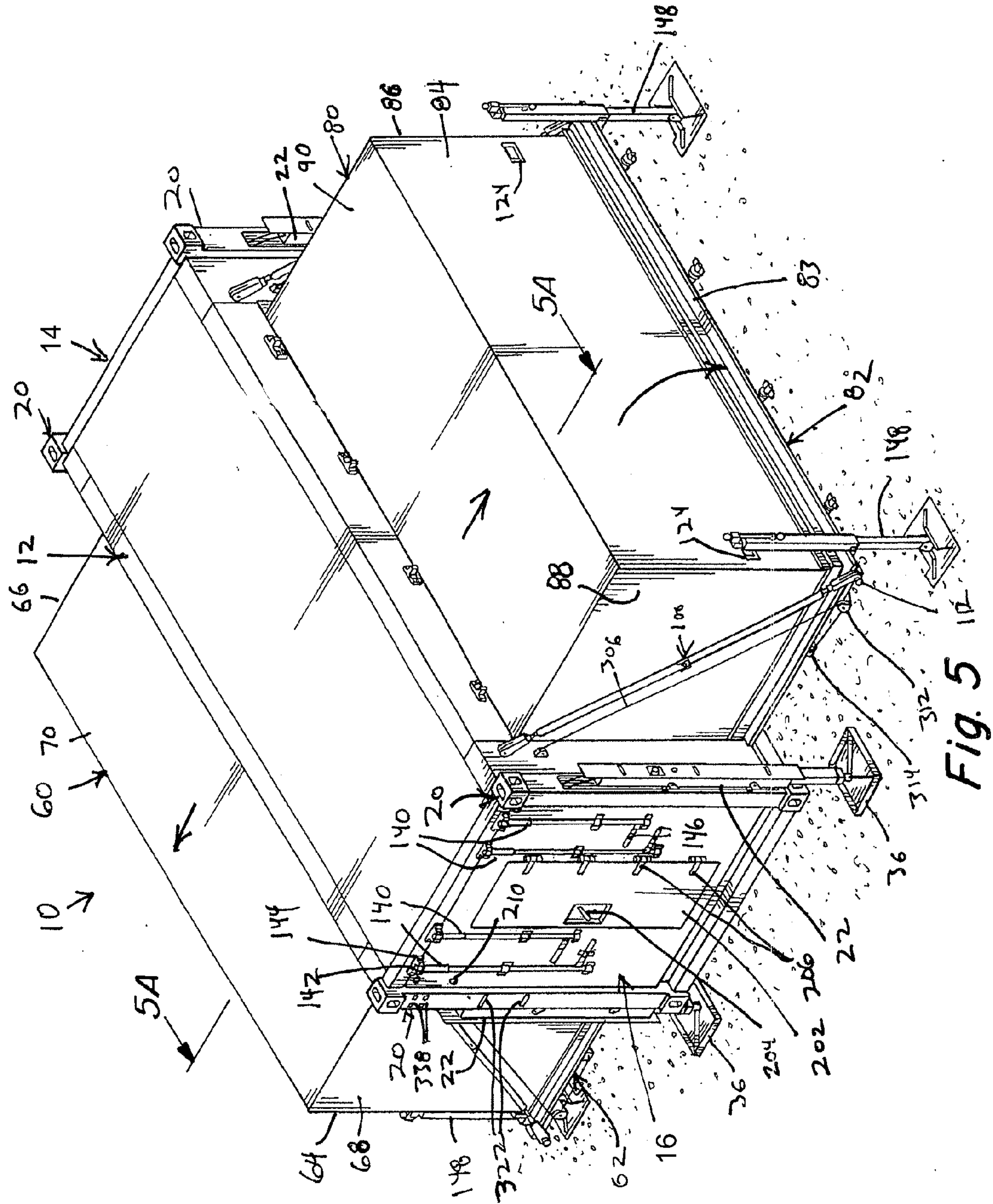
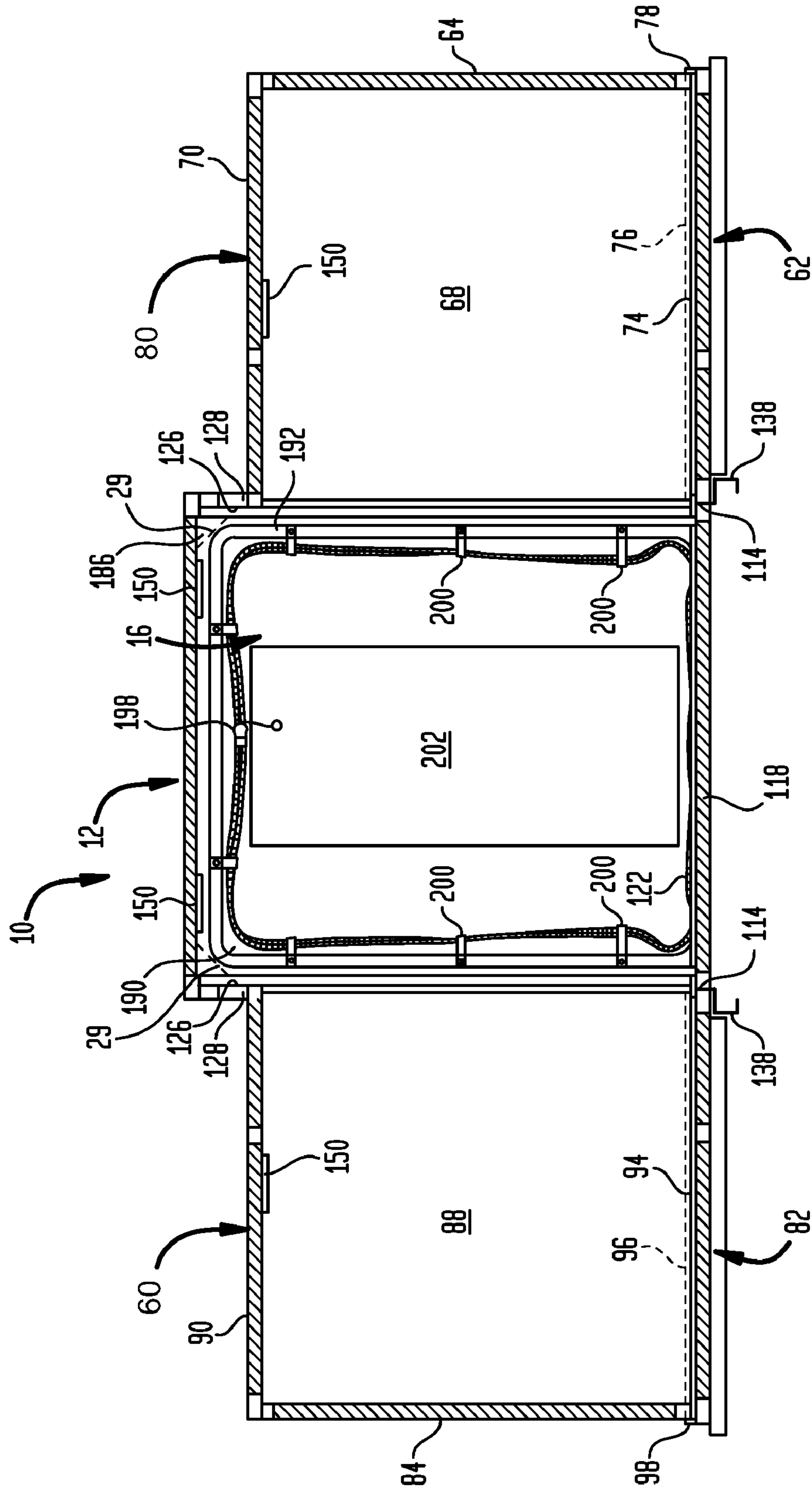

FIG. 5A



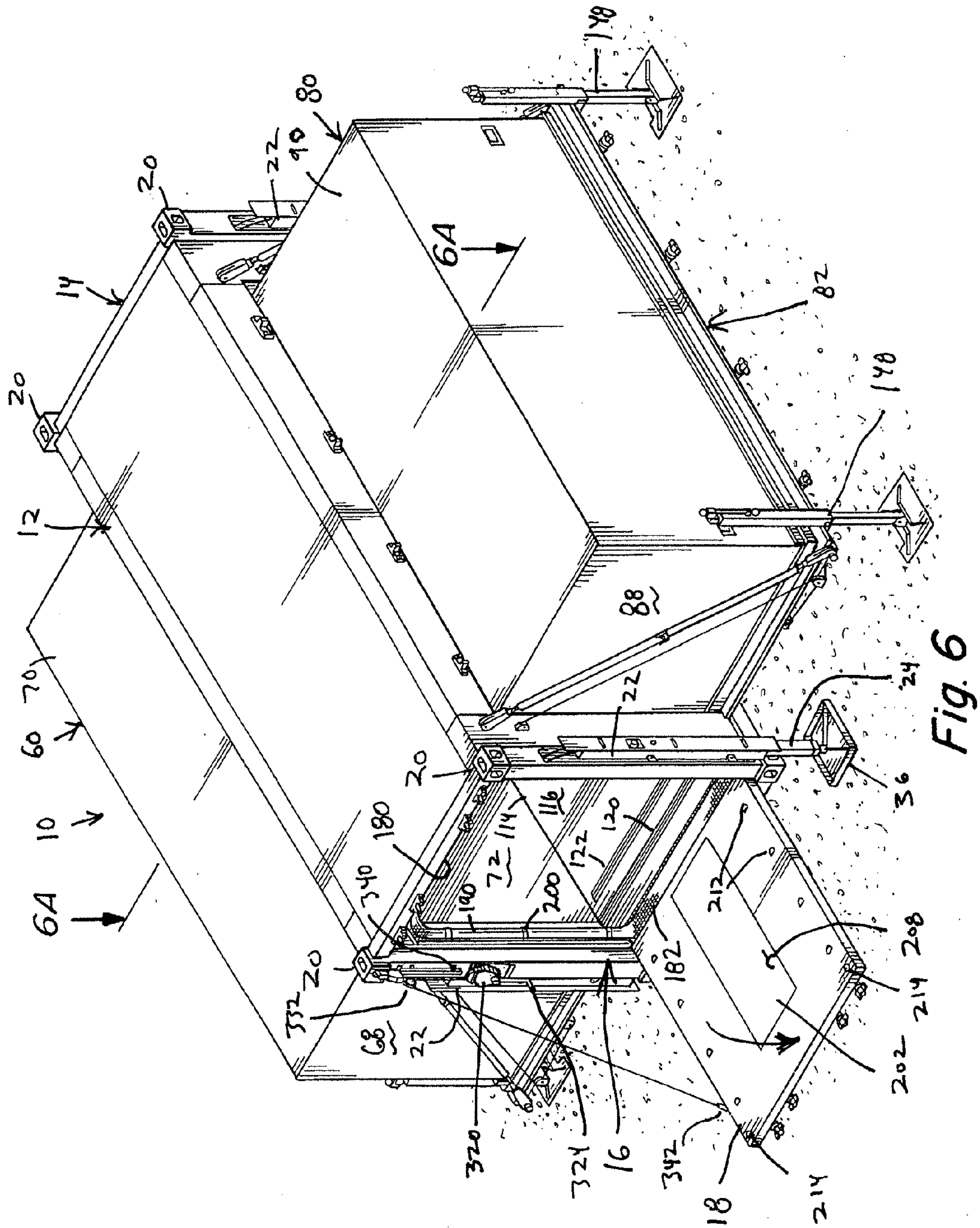

Fig. 6



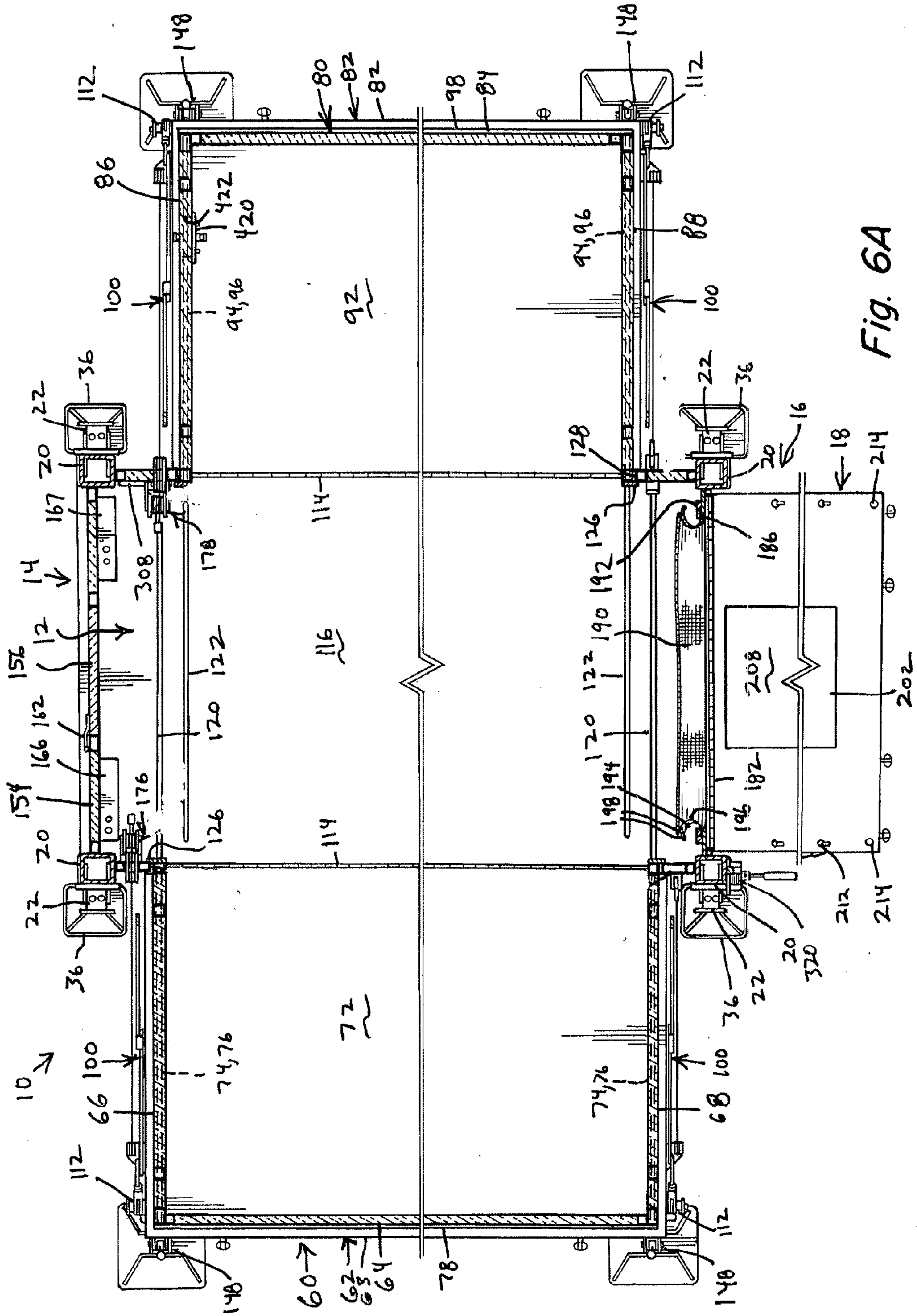

Fig. 6A

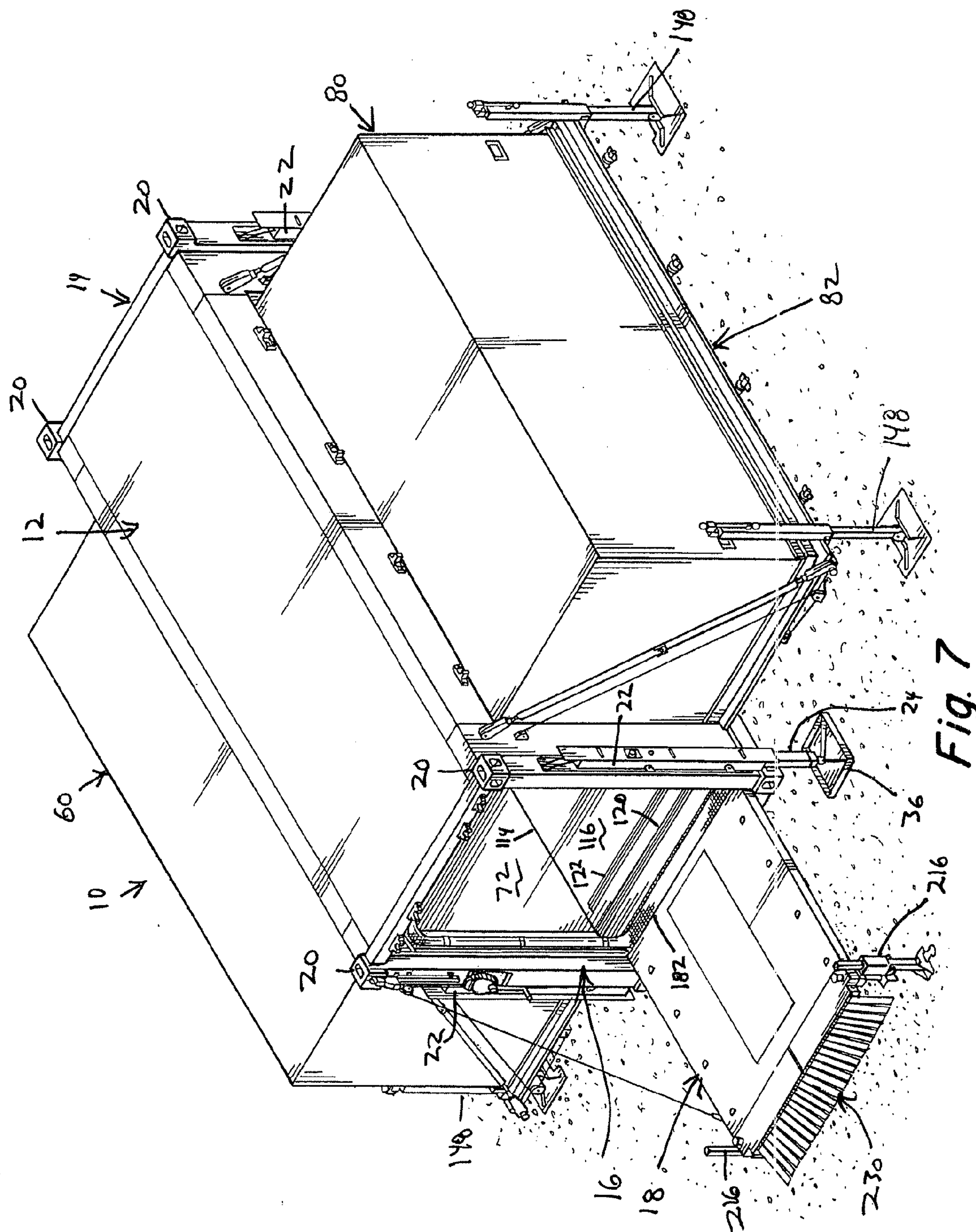

Fig. 7



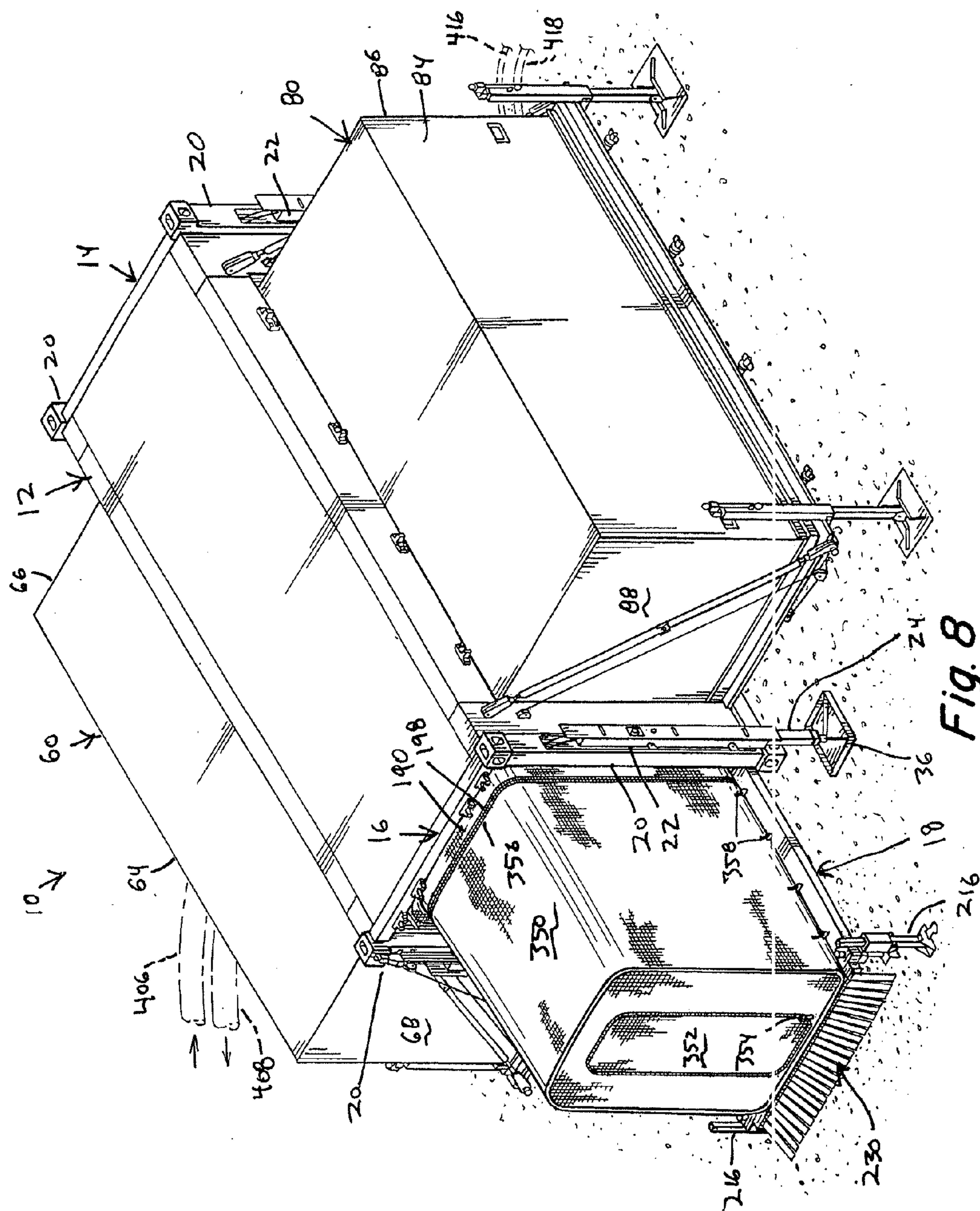

Fig. 8



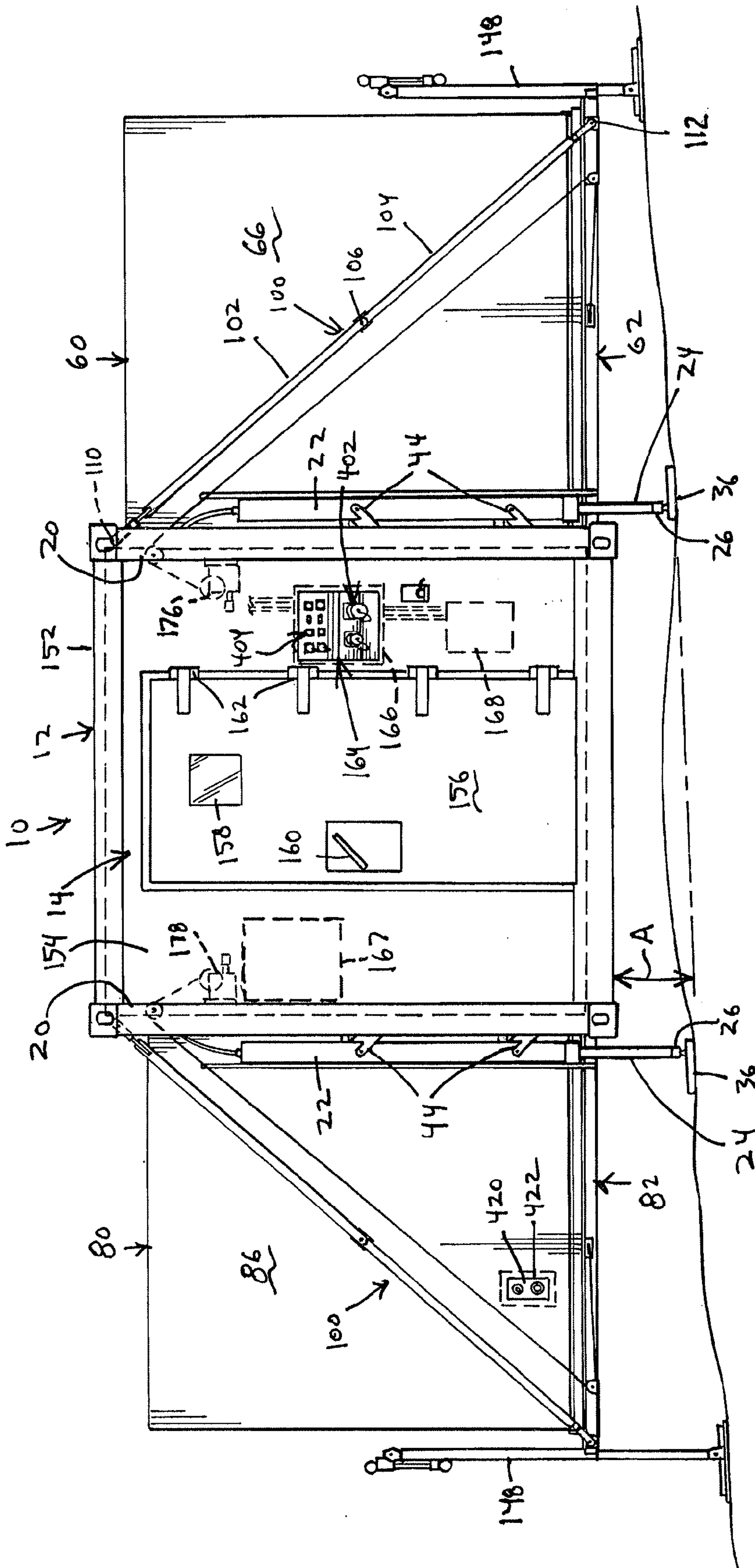

Fig. 9

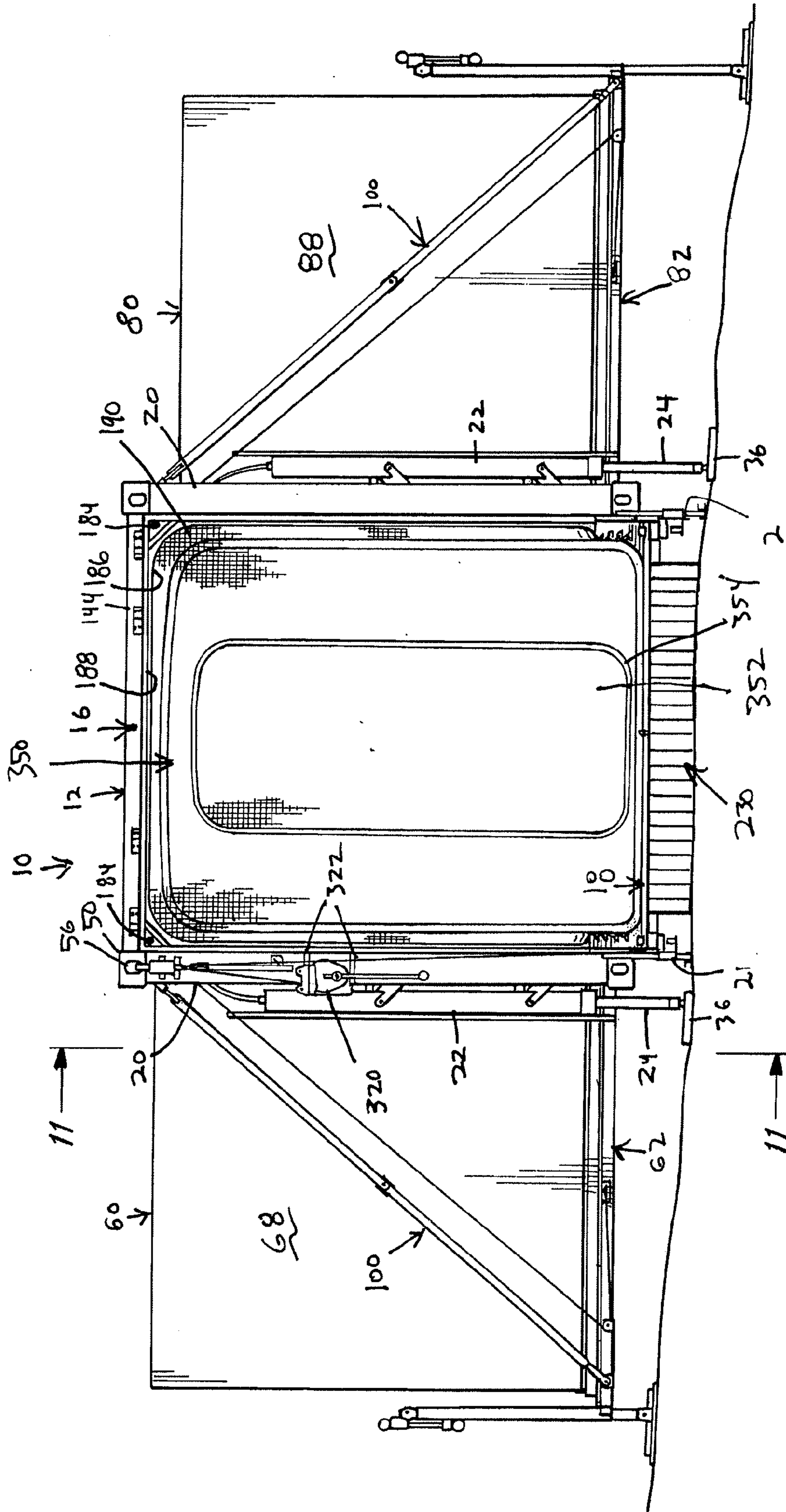

Fig. 10

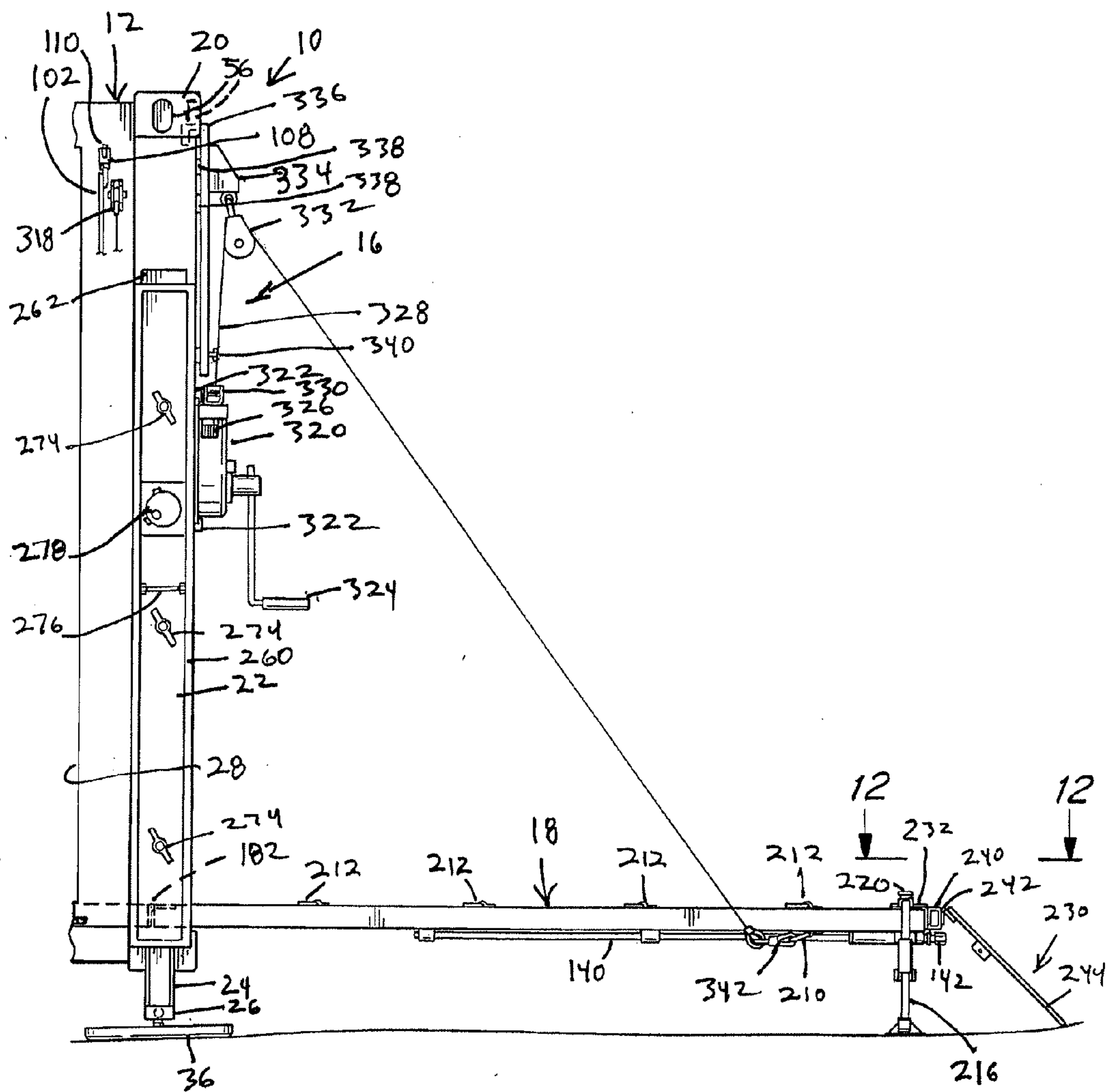

Fig. 11



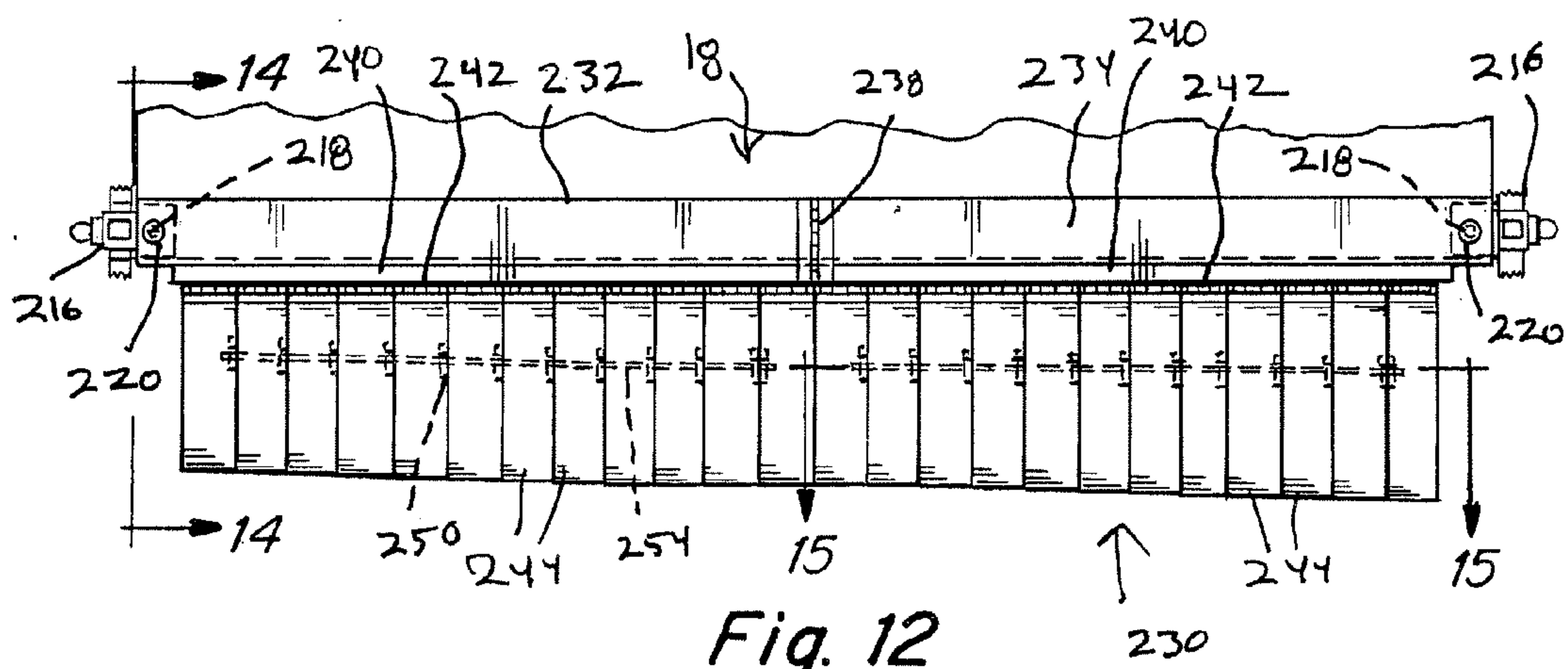

Fig. 12

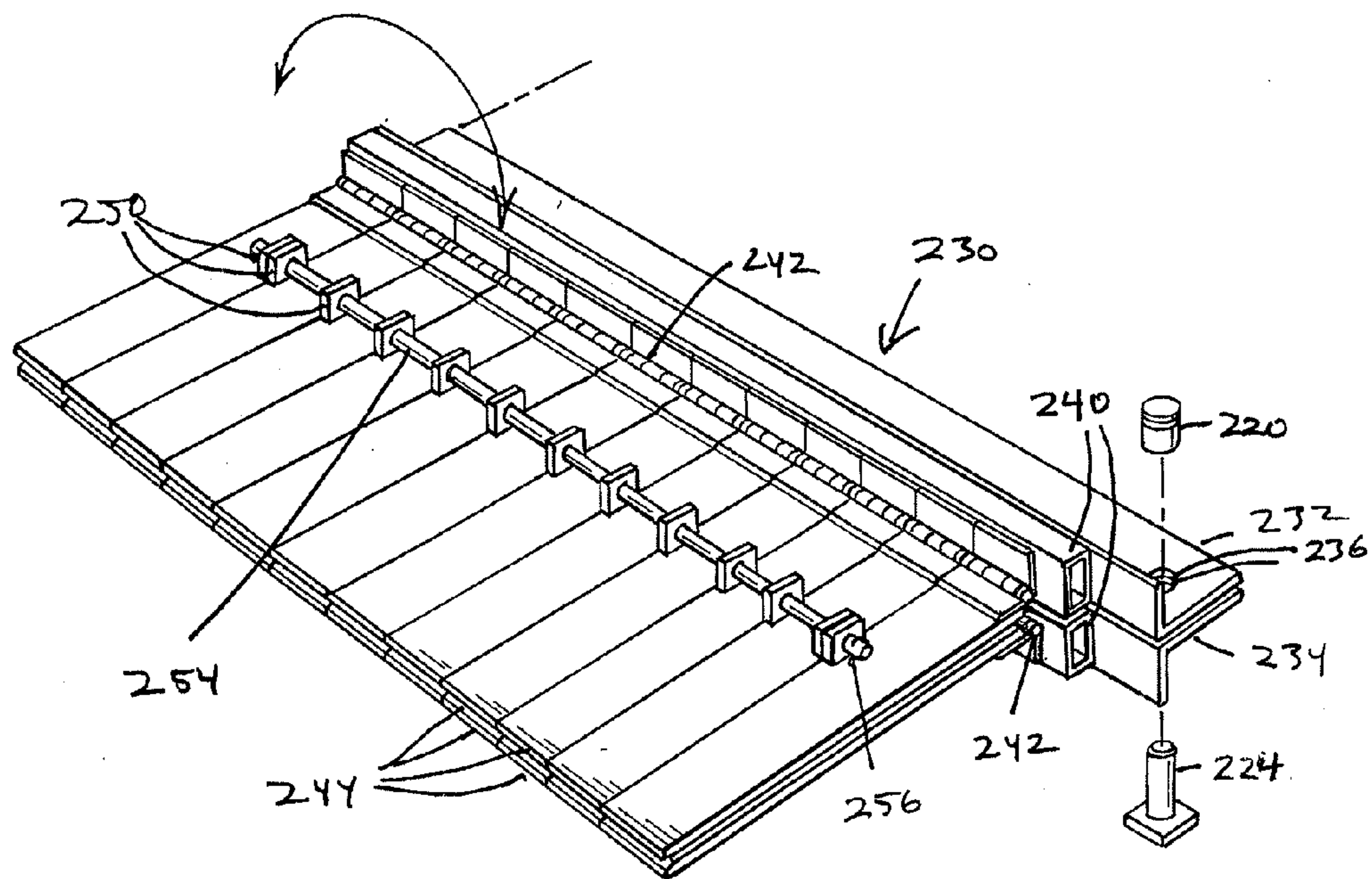

Fig. 13

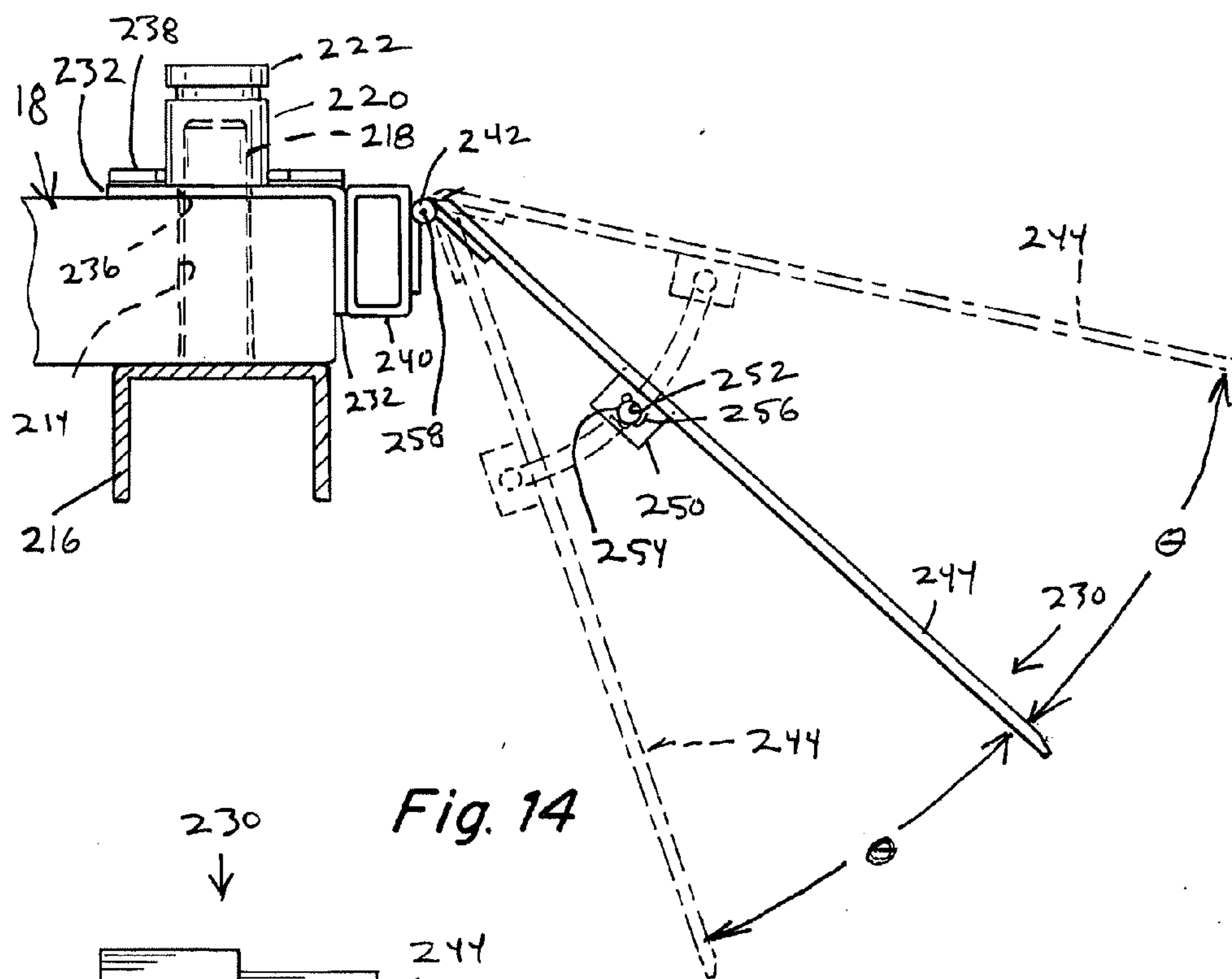

Fig. 14

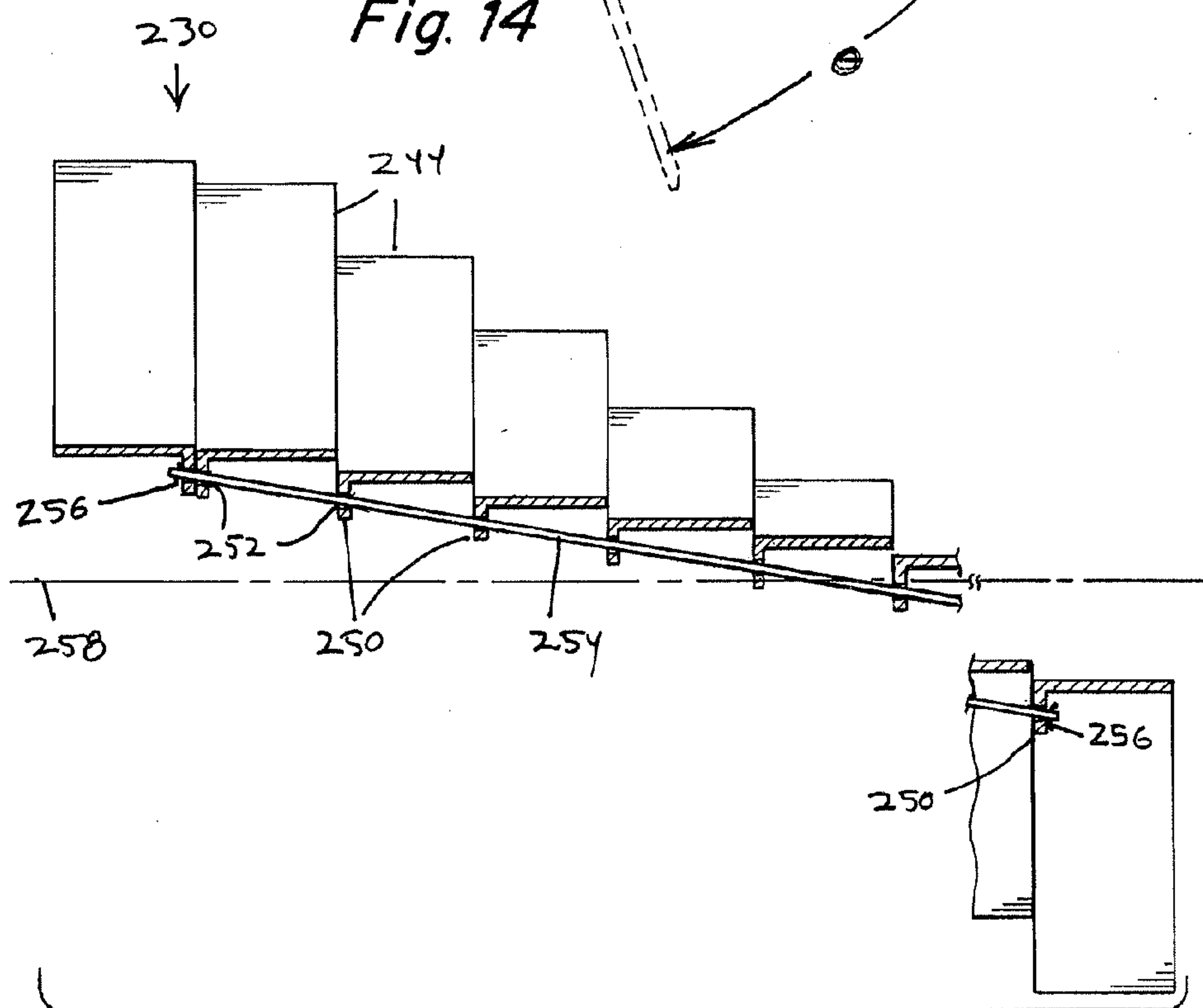

Fig. 15

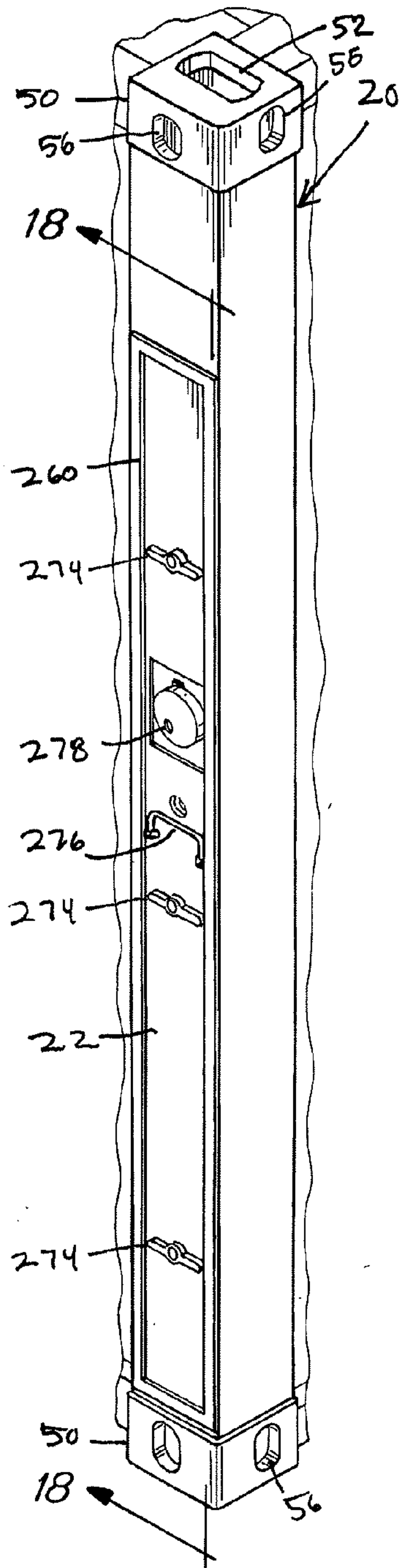

Fig. 16

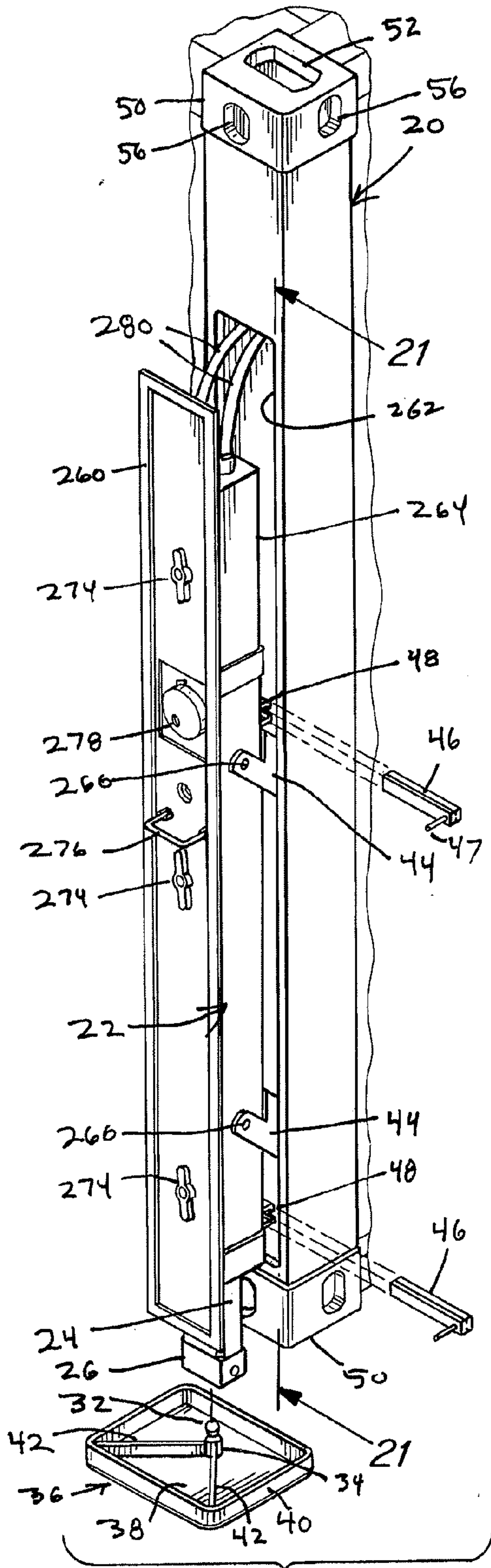

Fig. 17



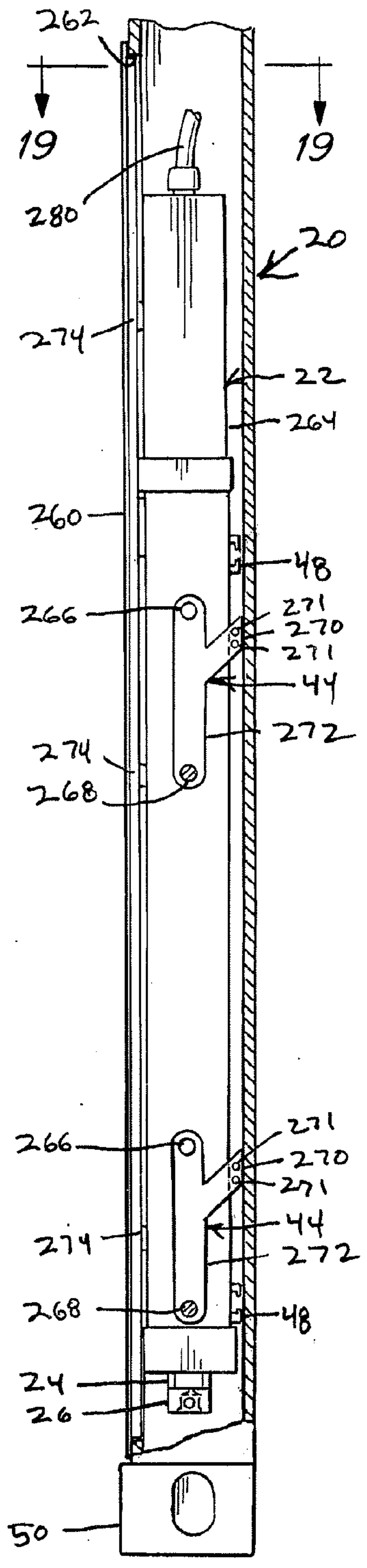

Fig. 18

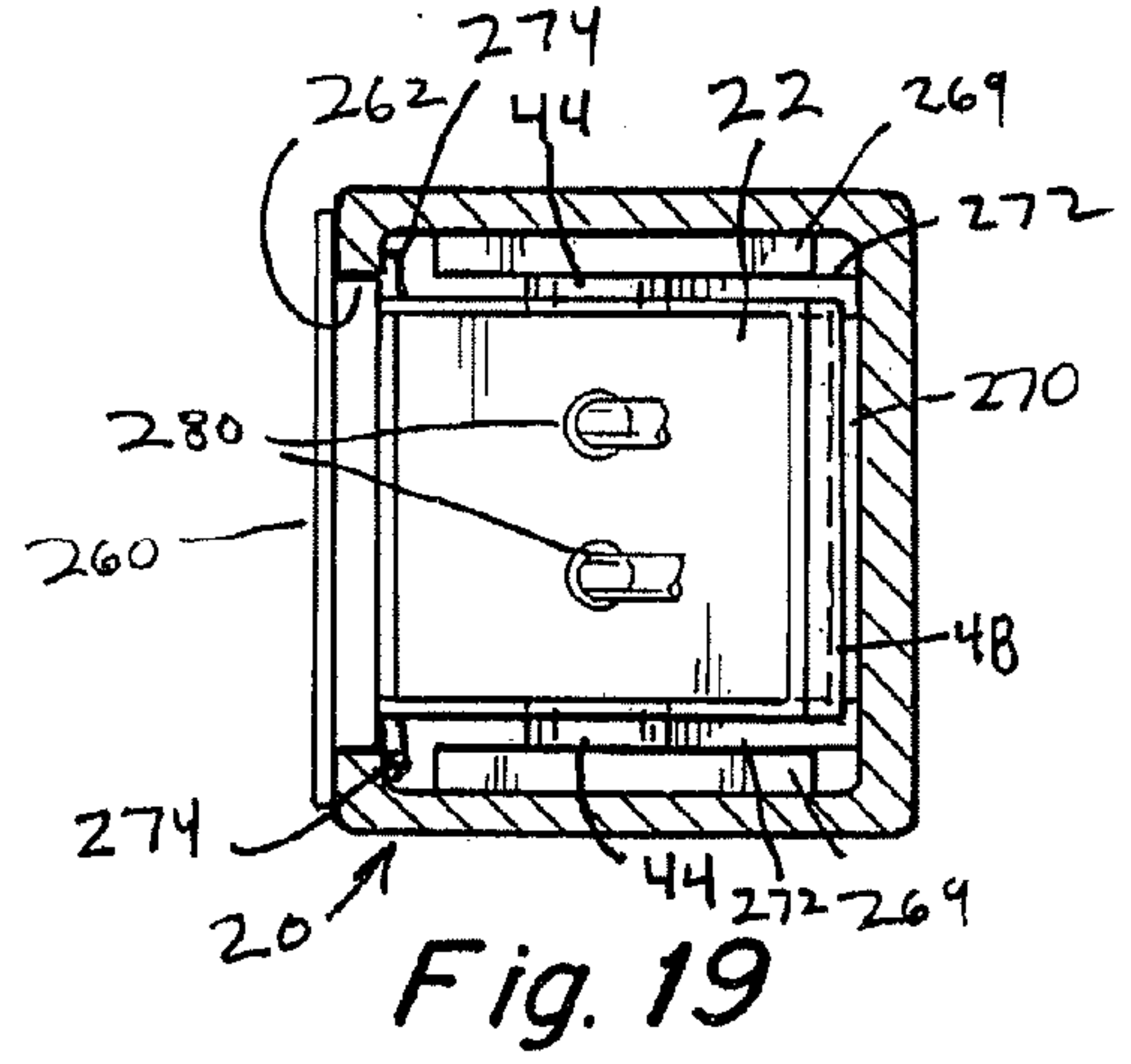

Fig. 19

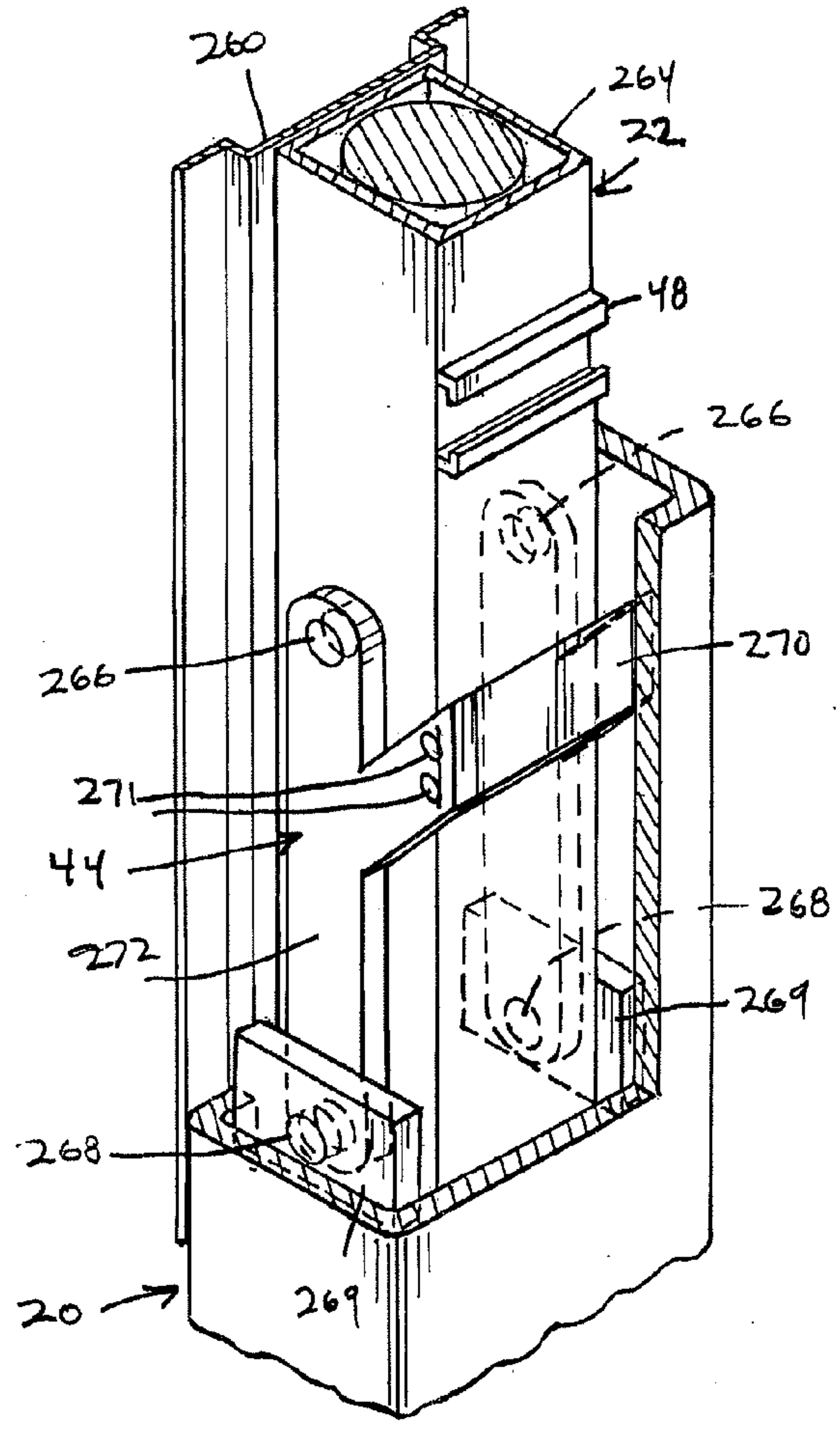

Fig. 20

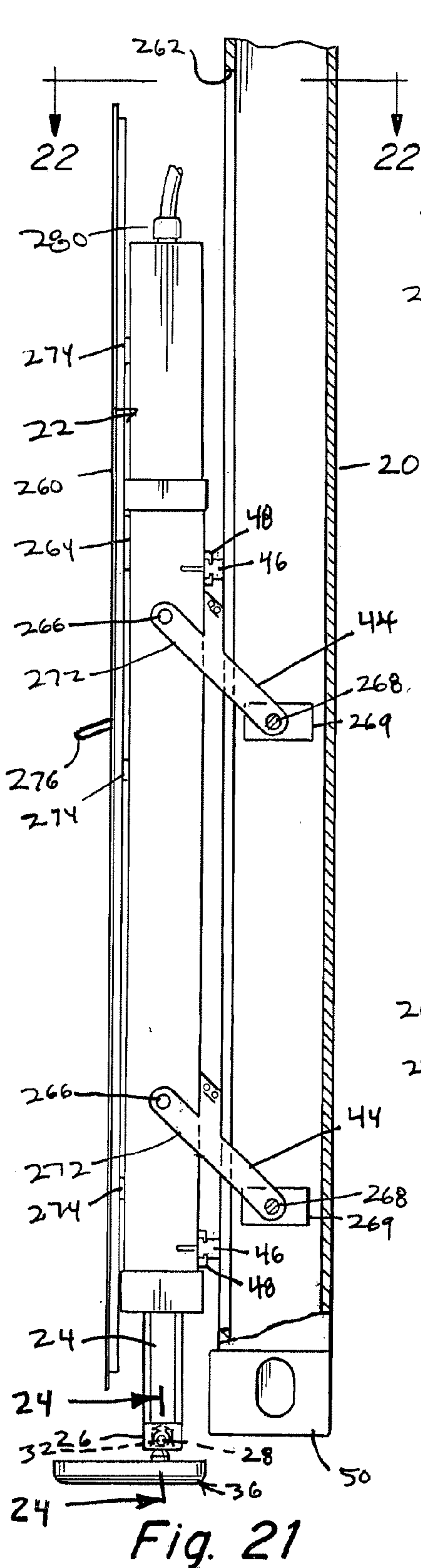

Fig. 21

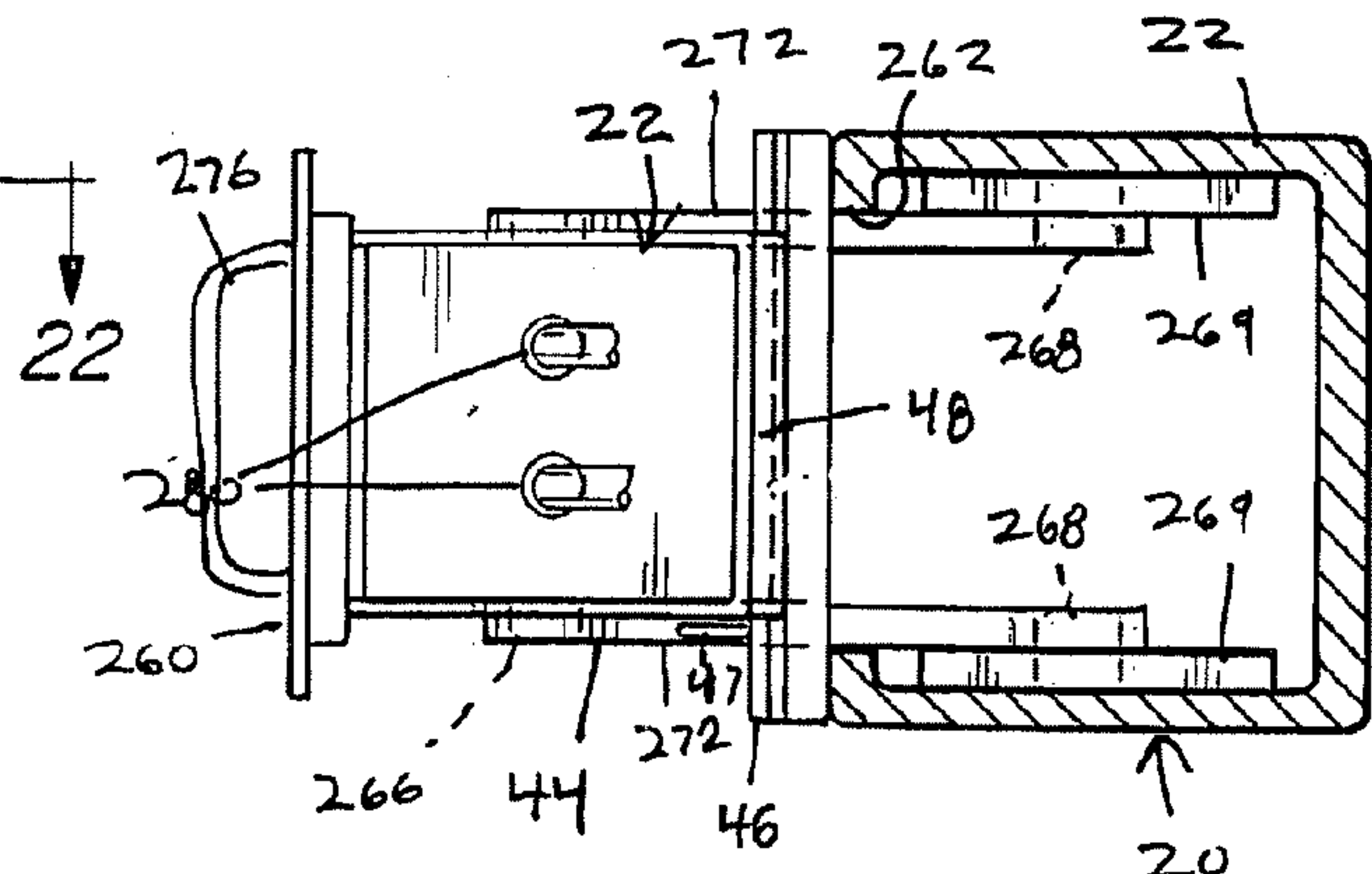

Fig. 22

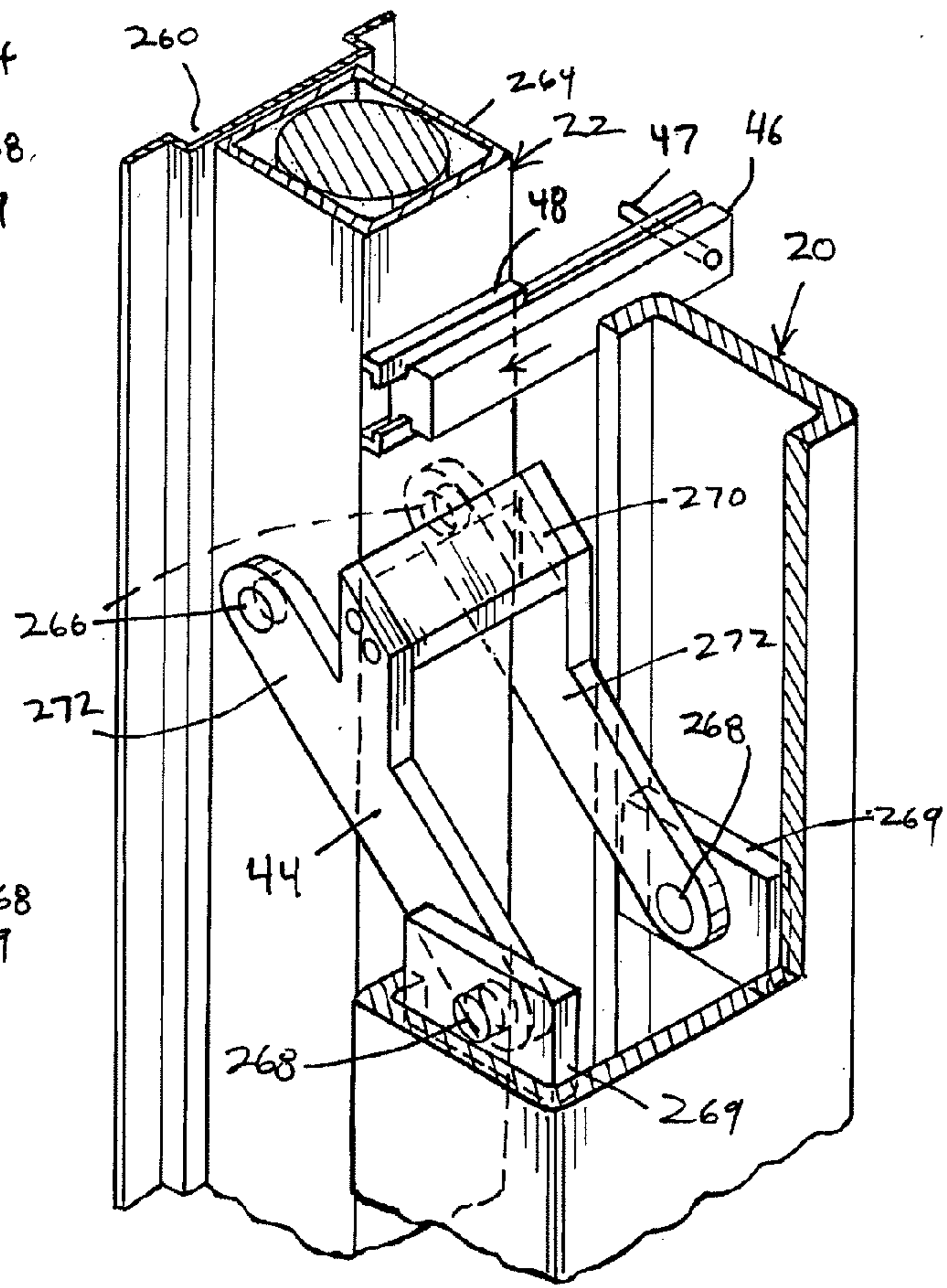

Fig. 23

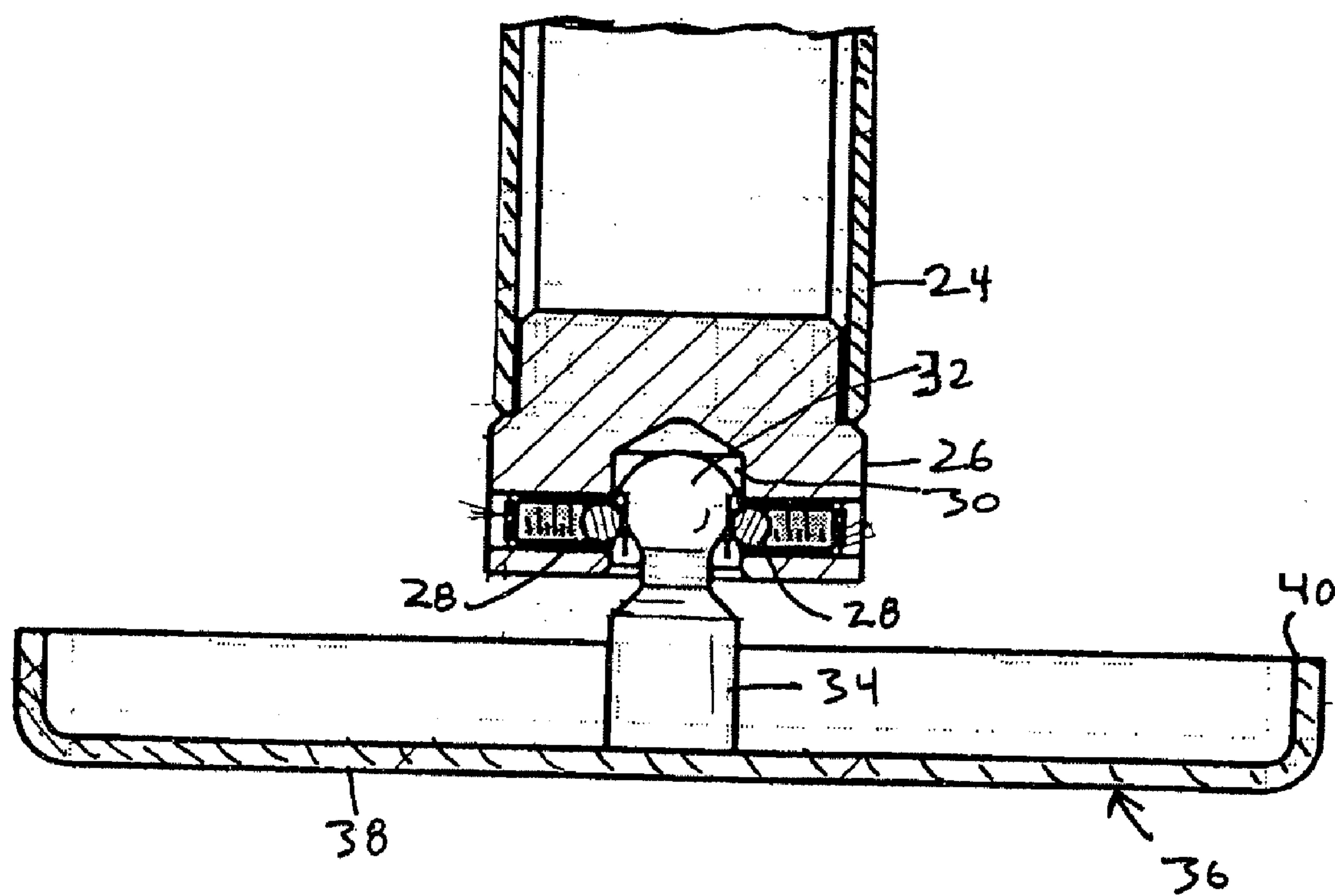

Fig. 24



## EXPANDABLE ISO SHELTERS

[0001] The present application claims the benefit of U.S. Provisional Patent Application 61/358,120; filed Jun. 24, 2010.

### STATEMENT REGARDING FEDERALLY SPONSORED RESEARCH OR DEVELOPMENT

[0002] The work resulting in this invention was supported in part by the U.S. Army Medical Material Development Agency (USAMMDA) under Contract No. W81XWH08-C-0060. The U.S. Government has certain rights in the invention.

### BACKGROUND

[0003] 1. Field of Invention

[0004] The present application relates to a shelter system, and more particularly, to an expandable shelter system.

[0005] 2. Related Art

[0006] Deployable shelter systems generally provide self-contained shelters for use in a variety of environments. Deployable shelter systems are known which are configured to be in the size and shape of a standard ISO (International Organization for Standardization) shipping container. In this way, the shelters may be shipped by commercial means, such as by railway, boat or aircraft, including military aircraft. Such a shelter may be deployed at a remote location. These shelters typically are expandable from the size of an ISO container to a larger size. Such shelters may be used for a variety of purposes, such as medical, temporary housing, disaster recovery, meeting space, office space, or laboratory space.

### SUMMARY

[0007] In accordance with one aspect of the present invention, an expandable shelter is provided. The expandable shelter has an expanded configuration and a collapsed configuration in which the shelter has the approximate dimensions of a standard International Organization for Standardization (ISO) freight container. The shelter comprises first and second substantially parallel corner posts, the first and second corner posts are disposed at a first end of the shelter. The first and second corner posts have first and second ends. The shelter also comprises an upper frame support extending between the first ends of the first and second corner posts. The shelter additionally comprises a lower frame support extending between the second ends of the first and second corner posts. The shelter also comprises a wall support attached to the first and second corner posts and the upper frame support. The shelter further comprises a displaceable panel hinged at the first end of the shelter and configured to fit securely on the interior of the first and second corner posts when in a closed configuration in which the displaced panel is disposed between the first and second corner posts, wherein the shelter has sufficient strength to withstand the forces of at least eight similar shelters stacked on top of the shelter.

[0008] In accordance with another aspect of the present invention, an expandable shelter is provided. The expandable shelter has an expanded configuration and a collapsed configuration in which the shelter has the approximate dimensions of a standard International Organization for Standardization (ISO) freight container. The shelter comprises first

and second substantially parallel corner posts disposed at a first end of the shelter. The shelter also comprises a ramp coupled with hinges at the first end of the shelter and configured to fit securely on the interior of the first and second corner posts when in a closed configuration in which the ramp is disposed between the first and second corner posts, wherein the shelter has sufficient strength to withstand the forces of at least eight similar shelters stacked on top of the shelter.

[0009] In accordance with a further aspect of the present invention, an expandable shelter is provided. The expandable shelter has an expanded configuration and a collapsed configuration in which the shelter has the approximate dimensions of a standard International Organization for Standardization (ISO) freight container. The shelter comprises first and second substantially parallel corner posts, the first and second corner posts are disposed at a first end of the shelter. The first and second corner posts have first and second ends. The shelter also comprises an upper frame support extending between the first ends of the first and second corner posts. The shelter additionally comprises a lower frame support extending between the second ends of the first and second corner posts. The shelter also comprises a wall support attached to the first and second corner posts and the upper frame support. The shelter additionally comprises a fabric connector connected to the wall support. The shelter further comprises a displaceable panel hinged at the first end of the shelter and configured to fit securely on the interior of the first and second corner posts when in a closed configuration in which the displaced panel is disposed between the first and second corner posts, wherein the shelter has sufficient strength to withstand the forces of at least eight similar shelters stacked on top of the shelter.

### BRIEF DESCRIPTION OF DRAWINGS

[0010] The accompanying drawings are not intended to be drawn to scale. In the drawings, each identical or nearly identical component that is illustrated in various figures is represented by a like descriptor. For purposes of clarity, not every component may be labeled in every drawing.

[0011] The advantages and features of this invention will be more clearly appreciated from the following detailed description, when taken in conjunction with the accompanying drawings, in which:

[0012] FIG. 1 is a perspective view of multiple, stacked deployable, expandable, shelters;

[0013] FIG. 2 is a front, perspective view of a single deployable, expandable, shelter in a retracted condition;

[0014] FIG. 2A is a schematic, cross-sectional end view taken along the line 2A-2A of FIG. 2;

[0015] FIG. 3 is a front, perspective view of a single deployable, expandable, shelter of this invention;

[0016] FIG. 3A is a schematic, cross-sectional end view taken along the line 3A-3A of FIG. 3 showing a first floor panel being lowered;

[0017] FIG. 4 is a front, perspective view showing the floor panel in a lowered condition;

[0018] FIG. 4A is a schematic, cross-sectional end view taken along the line 4A-4A of FIG. 4 showing one section in a deployed condition;

[0019] FIG. 5 is a rear perspective view of the deployable, expandable shelter of this invention in a deployed condition;

[0020] FIG. 5A is a schematic, cross-sectional end view taken along the line 5A-5A of FIG. 5;



[0021] FIG. 6 is a rear perspective view illustrating the ramp of this invention in a lowered position;

[0022] FIG. 6A is a schematic, cross-sectional plan view taken along the line 6A-6A of FIG. 6;

[0023] FIG. 7 is a rear perspective view illustrating the ramp transition panel of this invention;

[0024] FIG. 8 is a rear perspective view of the deployable, expandable shelter of this invention in a deployed condition with a fabric portico;

[0025] FIG. 9 is a front elevational view of the deployable, expandable shelter of this invention in a deployed condition;

[0026] FIG. 10 is a rear elevational view of the deployable, expandable shelter of this invention in a deployed condition;

[0027] FIG. 11 is a fragmentary side view of one end of the deployable, expandable shelter of this invention as seen along line 11-11 of FIG. 10;

[0028] FIG. 12 is a fragmentary plan view of the ramp of FIG. 11 as seen along line 12-12 of FIG. 11;

[0029] FIG. 13 is a perspective view of the ramp transition panel of FIG. 11 in a folded position;

[0030] FIG. 14 is a schematic end view of the ramp as seen along line 14-14 of FIG. 12;

[0031] FIG. 15 is a schematic cross-sectional view of the skirt taken along line 15-15 of FIG. 12;

[0032] FIG. 16 is a front perspective view of a corner post showing a jack in a stowed position;

[0033] FIG. 17 is a front perspective view of the post of FIG. 16 showing the jack in a deployed position;

[0034] FIG. 18 is a cross-sectional side view taken along the line 18-18 of FIG. 16;

[0035] FIG. 19 is a cross-sectional plan view taken along the line 19-19 of FIG. 18;

[0036] FIG. 20 is a fragmentary, rear perspective view, partially cut-away, of a hinge assembly of FIG. 18;

[0037] FIG. 21 is a cross-sectional side view taken along the line 21-21 of FIG. 17;

[0038] FIG. 22 is a cross-sectional plan view taken along the line 22-22 of FIG. 21;

[0039] FIG. 23 is a fragmentary, rear perspective, partially broken-away view of a hinge assembly of FIG. 21; and

[0040] FIG. 24 is a cross-sectional front view of a foot mounted to a ram taken along line 24-24 of FIG. 21.

#### DETAILED DESCRIPTION

[0041] The present invention relates to a deployable, expandable, shelter which may be expanded from a collapsed condition in which it has the size and shape of a standard ISO container to a condition in which it is about three times its original, collapsed size. The collapsed shelter of the present invention can be stacked nine units high for shipping or storage. The shelter of the present invention, when deployed, may be used for hospital or medical purposes, laboratory space, disaster recovery, temporary housing, meeting or office space, or other like purposes.

[0042] In one embodiment, the deployable, expandable shelter may be transported along with other standard ISO shipping containers by cargo aircraft, military aircraft, rail, truck and container ship. For example, two such shelters can be accommodated in a military C-130 aircraft. The shelters may be stacked one on top of the other to a height of nine for shipping on the deck of a container ship or for storage. These shelters are built to structural standards for shipping containers and to comply with ISO 1496/1 test requirements.

[0043] One end of the shelter may be provided with a panel which forms the end wall of the shelter in a collapsed condition and which may be pivoted downwardly about a bottom hinge to form a ramp. A portico may be attached to the shelter by a fabric connector on a wall support when the ramp is lowered. The wall support provides strength and rigidity to that end of the shelter. The portico permits the maintenance of a controlled environment, or a sterile environment in the interior of the shelter. The ramp end may be provided with stabilizers.

[0044] The end of the ramp may be provided with a flexible transition panel. The transition panel provides a transition from the ramp end to the ground or to another ramp, and is flexible to accommodate an uneven ground surface. This permits easy movement of wheeled objects to and from the interior of the shelter through, for example, a portico.

[0045] Corner posts are provided at each corner of the shelter. These posts are load-bearing, and are reinforced to permit stacking of the shelter. The corner posts may be provided with jacks that may pivot outwardly from the post. Typically the jacks are provided with feet, such as sand feet, which assist in stabilizing the shelter. The jacks in the posts level the shelter. These jacks may be either manually operated, or, if access to power is provided, there is a self-leveling system which automatically levels the shelter. Each of the expanded modules of the shelter are also provided with stabilizers having feet which permit leveling of those portions of the shelter.

[0046] In one embodiment, panels which serve as the side panels to the shelter when collapsed are pivoted downwardly and serve as floor panels for first and second modules on either side of the shelter when in an expanded condition. The side walls and top walls of the modules on either side of the shelter may be rolled or slid outwardly along rails disposed on the floor panels. Each floor panel may be lowered by a winch, which could be manually operated or power operated.

[0047] One embodiment of shelter 10 of this invention will now be described with respect to FIGS. 1 and 2. FIGS. 1 and 2 illustrate a typical shelter 10 in a collapsed configuration. When in a collapsed configuration, shelter 10 may have the configuration of a standard ISO container, which is typically twenty feet long, eight feet wide, and eight feet high. As shown in FIG. 1, shelter 10 may be stacked on top of other shelters 10, or ISO containers with which it is compatible. In this manner, a shelter 10 or multiple shelters 10 can be shipped by means of cargo aircraft, military aircraft, rail, truck or container ship to a desired location. In one example, two such shelters 10 may be accommodated in a C-130 aircraft for deployment. Moreover, the shelters 10 may be stacked in a storage facility along with ISO containers. In one embodiment, shelters 10 are configured so as to be able to be stacked nine high, as illustrated in FIG. 1, which shows containers 10a through 10i in a stacked configuration. Shelters 10a-i preferably are built to satisfy ISO 1496/1 test requirements.

[0048] Shelter 10 includes a main section 12 which has a first end 14, a second end 16, a roof 152, a floor panel 118 having a floor surface 116, panel 62, panel 82, and four corner posts 20. As shown in FIG. 2A, shelter 10 may further include a first expandable module 60 and a second expandable module 80. When in a collapsed condition, modules 60 and 80 are fully disposed within main section 12. The side of section 12 includes upper structural frame members 17, lower structural frame members 138 and side structural frame members 13.



Upper and lower frame members **17** and **138** may extend between posts **20** on both sides of section **12**. Side frame members **13** may be affixed to posts **20** on either side of panels **62** and **82**. Frame members **17**, **138** and **13** may be formed of aluminum or other suitable materials. Ends **14** and **16** may include upper frame supports **21** and lower frame supports **23**, which may be formed of steel or aluminum or the like.

[0049] Corner post **20** will now be described with particular reference to FIGS. **16-23**. There are four corner posts **20** which are the main support elements of shelter **10**. Corner posts **20** may be made of heavy gauge, welded steel. Gusset plates **29** (see FIG. **2A**) may be provided at the top and bottom ends of posts **20** to provide greater strength and rigidity. Each corner post typically has a connection block **50** attached such as by welding to its top and bottom ends. Each block **50** typically has holes **52** formed in the top and bottom surfaces thereof to allow a standard container connector **54** to be inserted therein. Connectors **54** may be used to clamp shelters **10** together vertically. Holes **56** formed on the sides of blocks **50** may be used for interfacing with a crane, forklift or other like mechanism for movement of shelter **10** from one place to another.

[0050] In one embodiment, each post **20** contains a jack **22**. FIG. **16** shows a jack **22** in a stowed or normally retracted position, while FIG. **17** shows a jack **22** in a deployed condition. Jack **22** typically includes a ram **24** for leveling of shelter **10**. Typically, each jack **22** is disposed within a housing **264**. Housing **264** may be disposed within an interior cavity of post **20** in the retracted position. A cover plate **260** may be disposed on the front of housing **264**. In one embodiment, cover plate **260** may have integral cross bolts **274** that may lock the cover plate **260** and jack **22** in a stowed position as seen in FIG. **19**. A bracket **276** may be attached to the front of cover plate **260** and may be used to manually pull the jack **22** out of the post **20** and swing it into its deployed condition. There may also be a manual access knob **278** that permits access to a socket for a hand crank that can be used to manually crank down the ram **24** of jack **20**, for leveling of shelter **10** in the absence of any power. Alternatively, or in addition, ram **24** may be driven by an electromechanical motor. Electrical power and sensor wires **280** may be attached at connectors at the top end of housing **264**. The bottom end of ram **24** may be filled with a stabilizing foot **36**.

[0051] Foot **36** may have a base plate **38** with flanges **40** and reinforcing ribs **42**. Foot **36** may include a post **34** which is attached at a bottom end to the base plate **38**. The top end of post **34** may include a spherical head **32**. The bottom end of each ram **24** may be fitted with a spring ball connector **26** which is shown in FIG. **24**. Connector **26** may be a block which is attached to the bottom of ram **24** and which has a central socket **30** with two spring balls **28**. When foot **36** is aligned with and moved upwardly toward spring balls **28**, head **32** will snap into place between spring balls **28** to retain foot **36** in a pivoting relationship with respect to the end of ram **24**.

[0052] A hinge **44** having arms **272** may be attached to pins **266** on housing **264**. Hinge arms **272** may be fitted onto pins **268** on spacers **269** which are attached to the inside of post **20**. Hinges **44** permit pivoting of jack **22** outwardly with respect to post **20**. A stop **270** may be attached at **271** to the hinge arms **272**. When jack **22** is in a stowed position, stop **270** abuts the inside of post **20** and when jack **22** is in a deployed condition, stop **270** abuts housing **264**, preventing further outward pivoting or movement of jack **22**. As shown in FIG.

**17**, in one embodiment, cross bolt guides **48** may be attached to the rear of housing **264**. When jack **22** is deployed, a cross bolt **46** may be inserted into guides **48** until stop **47** hits housing **264**. The cross bolt **46** spans the opening to the post **20** and blocks the jack **22** and prevents it from pivoting back into a stowed position under load.

[0053] Panel **62** may form a side panel of section **12** when in a collapsed condition, but may form a floor panel of first expanded module **60** when in an expanded condition as will be described. Similarly, panel **82** may form a side panel of section **12** when in a collapsed condition, but may form a floor panel of the second expandable module **80** when in an expanded condition. Locking bars **140** hold panels **62** and **82** in place in a collapsed condition. Locking bars **140** are conventional, and may include cam **142** at one end which may be inserted into a receiver **144**. The cam **142** is rotated into a locking position by handle **146** which, when the locking bar is fully locked, is flush with the outer surface of panel **62** or **82** and may be held in place with clamp **147**.

[0054] The first end **14** containing a first end wall **154** may include a door **156**. Door **156** may contain a latch **160** and is mounted on hinges **162**. A window **158** may be provided in door **156**. Second end **16** may include a wall support **186**, a frame **188** and an opening **180** for a ramp **18** which pivots downwardly, as will be described. Ramp **18** may include a door **202** having a handle **204** mounted on hinges **206**.

[0055] First expandable module **60** will now be described with particular reference to FIGS. **2-4A**. As previously noted, panel **62** which forms the outer wall of section **12** when in a collapsed condition, is pivoted downwardly, as shown in FIG. **4**, to form a floor panel for the first expandable module **60**. First expandable module **60** also includes a side wall **64**, a first end wall **66** and a second end wall **68**, a ceiling **70** and a floor surface **72** which is disposed on the inside surface of the panel **62**. Panel **62** is pivotally attached to lower frame member **138** of section **12** at hinges **114** (FIG. **5A**). When pivoted downwardly, panel **62** may be supported by two support arms **100**, one at each side of panel **62**. Typically, although not necessarily, each support arm **100** is formed of two rigid links, an upper link **102** and a lower link **104**, which are connected at hinge **106**.

[0056] Each support arm **100** typically is anchored at an upper end at anchor point **110** to an adjacent side frame member **13** of section **12**. The lower end of each support arm **100** typically is attached to panel **62** at an anchor point **112**. Typically, although not necessarily, turnbuckles **108** are provided at the upper and lower end of each support arm **100** at anchor points **110** and **112** to adjust the length of the support arm to equalize the length on both sides, and to ensure that when deployed, panel **62** is substantially horizontal.

[0057] Panel **62** is typically lowered by a cable **306** which is attached to a winch **176**. Winch **176** may be mounted to any suitable interior surface of main section **12**, such as panel **14** or side frame member **13**, on a surface thereof facing the inside of section **12**. Winch **176** may be manually operated. In another embodiment, winch **176** may be operated using a tool such as a drill D as shown in FIG. **3A**, which is coupled to a drive socket **302** on the winch **176**. Winch **176** includes a reel **304**. Cable **306** may pass from reel **304** through side frame member **13** over a pulley block **310**. Cable **306** may extend from pulley block **310** along end wall **66** to pulleys **312** on one side of panel **62** and over pulley **314**. Cable **306** may extend along the outside surface of panel **62** through cable guide **316**, as shown in FIG. **3**, to pulleys **312**, **314** on the side of panel **62**



opposite winch 176. Cable 306 may extend along end wall 68 to anchor 318 mounted on side frame member 13. By passing cable 306 across the entire outside surface of panel 62, panel 62 is adequately supported during the deployment phase, and any torque or twisting of panel 62 during deployment is minimized.

[0058] Panel 62 may contain an outer lip 63 which abuts an upper frame member 17 when in a collapsed condition. Panel 62 may also be provided with a flange 78 that extends about the free, outer perimeter of panel 62 to act as a stop to protect panel 62 when in the collapsed condition. Flange 78 may include a gasket to seal the interior of shelter 10 when in a deployed condition.

[0059] Rails 74 disposed on floor surface 72 of panel 62 and rails 120 disposed on floor surface 116 of section 12 accommodate slides or rollers 76 on the bottom of walls 66 and 68 to allow module 60 and associated walls 64, 66 and 68 and ceiling 70 to be slid or rolled outwardly away from section 12 in its collapsed condition to an expanded position as shown in FIG. 4A. Flange 78 may limit the movement of first expandable module 60 outwardly as it is pulled from its collapsed position. Typically two handles 124 may be provided, one at each end of panel 62, to allow two people to pull wall 64 and walls 66, 68 and ceiling 70 outwardly to deploy first expanded module 60.

[0060] FIG. 4A shows first expandable module 60 in its fully deployed condition. Module 60 is open at the end facing into the interior of section 12. A flange 126 may be provided on ceiling 70 to abut against an interior surface of section 12 to limit outward movement of module 60 and/or to minimize any twisting of the module resulting from downward tilting of module 60 with respect to section 12. Ceiling 70 of first expandable module 60 may include a light 150, such as flat LED lights or other lights that are recessed or do not project sufficiently far downwardly from ceiling 70 to interfere with movement of the modules 60 and 80 or with the head room within shelter 10.

[0061] Second expandable module 80 will now be described with particular reference to FIGS. 4A, 5, 5A and 6A. The second expandable module includes a floor panel 82, a sidewall 84, first end wall 86, a second end wall 88, and a ceiling 90. As can be seen, in one embodiment, ceiling 90 is spaced below ceiling 70 of module 60 to allow ceiling 70 to pass above ceiling 90 when the modules are in their collapsed position in section 12. Similarly, end walls 86 and 88 are positioned so as to be located inside end walls 66 and 68 when in a collapsed position. Thus, module 80 is somewhat smaller than module 60 to permit collapse of shelter 10. It is to be understood, however, that these positions could be reversed, so that ceiling 70 is positioned below ceiling 90 and walls 86 and 88 are outside walls 66 and 68 during the collapsed condition of the modules. Expandable module 80 is deployed in much the same fashion as first expandable module 60. Panel 82, which serves as a side wall of the container when in a collapsed condition is pivoted downwardly about hinges 114 to serve as a floor panel of module 80. Panel 82 may include a flange 98 to protect panel 82 when in the collapsed condition. Flange 98 may include a gasket to seal the interior of shelter 80 when in a deployed condition. Panel 82 may be connected to shelter 10 by support arms 100 which may have upper links 102 and lower links 104 which are coupled at hinge 106. Support arms 100 may be attached to panel 82 at anchor point 112 and to shelter 10 at anchor point 110 on side frame member 13. Turnbuckles 108 may be provided at each

end of arm 100. Cable 306 allows deployment of panel 82 in a fashion similar to panel 62 of the first expandable module 60. Cable 306 may extend from reel 304 of a winch 178, through pulley blocks 310, over pulleys 312 and 314, along the outside end wall 86 and may pass along the outside of side wall 84 through a cable guide 316, to another set of pulleys 312 and 314 at the other side of wall 84. Cable 306 may extend along end wall 88 to anchor 318 on side frame member 13.

[0062] Winch 178 may be manually operated, or connected to a drill or other power device through a socket 302. Winch 178 may be fixed to the wall like winch 176, or, in one embodiment, it may be mounted on rails or slides 308 to be movable to allow the winch 178 to be stowed out of the way of wall 66 when the shelter is collapsed. In particular, as shown in FIGS. 3A and 6A, slides or rails 308 may allow winch 178 to be moved toward first end 14 out of alignment with end wall 66 of first expandable module 60. In this way, when shelter 10 is collapsed, wall 66 may abut the inner wall of section 12 to allow module 60 to be collapsed as far as possible without interference from winch 178. Winch 176 is already out of alignment with any of the walls of first and second expandable modules 60 and 80, and therefore may be permanently mounted in position on the wall of section 12, if desired.

[0063] Like the first expandable module 60, the inside surface of panel 82 forms the floor surface 92 of second expandable module 80. Rails 94 are provided on surface 92 and rails 122 are provided on floor surface 116 to accept slides or rollers 96 on the bottom of walls 86 and 88 to permit the expansion of module 80. Flange 98 may limit movement of walls 86, 88 and 84 outwardly. A flange 126 may be provided on ceiling 90 to abut against an interior surface of section 12 to limit outward movement of module 80 and/or to minimize any twisting of module 80 resulting from downward tilting of module 80 with respect to section 12. Handles 124 may also be provided on sidewall 84 to permit manual expansion of module 80. Like module 60, module 80 may be provided with lights 150, such as flat LED lights or other lights that are recessed or that do not interfere with movement of modules 60 and 80 or with sufficient head room within shelter 10.

[0064] Stabilizers 148 may be provided adjacent the unsupported corners of panel 62 of module 60 and panel 82 of module 80. Typically, two such stabilizers 148 are provided for each panel 62 and 82. However, more stabilizers 148 may be utilized if necessary. Stabilizers 148 are attached to respective panels 62 and 82 at points 149 of the outer edge thereof, such as by means of a lip disposed beneath the edges of panels 62 and 82. Stabilizers 148 preferably are provided with an enlarged, flat foot on which they are mounted to provide stability. Stabilizers 148 may be provided with spring loaded ratchets which are adjustable in height to accommodate an uneven ground surface and which may be urged upwardly against the edges of panels 62 and 82.

[0065] The structure at second end 16 will now be described with reference to FIGS. 6-11. As noted, second end 16 may include a ramp 18 in opening 180 which is connected to the floor panel 118 of section 12 such as by a hinge 182. Ramp 18 may extend the entire distance between spaced posts 20 at second end 16. Ramp 18 may contain a door 202 mounted on hinges 206 (FIG. 5) which is flush with ramp 18. Door 202 may include a recessed latch 204 on the exterior or underside of ramp 18. Door 202 may be used as an access to the interior of section 12 for storing items, when ramp 18 is in an upright position. Ramp 18 may be provided with a smooth,



flush surface **208** on the interior or top side of the ramp to allow movement of cargo or the like thereover. When in an upright position, ramp **18** is held in place by, for example, locking bars **140**. Four such bars are illustrated in FIG. **10**. These locking bars are conventional and may have cam heads **142** that are urged into a snug relationship with receivers **144** when the handles are pivoted against the ramp by handles **146**, as shown in FIG. **5**. Clamps **147** may be provided for retention of the handles **146** in a stowed position.

[0066] Typically, extending around the perimeter of ramp opening **180**, there is a peripheral wall support **186**. Wall support **186** provides the required rigidity and strength to second end **16** and permits ramp **18** to extend from post **20** to post **20** to provide the widest ramp possible without sacrificing strength or rigidity. Wall support **186** may be formed of steel. Wall support **186** is attached to posts **20**. Bumpers, such as rubber bumpers **184**, may be provided on wall support **186** at the upper end of the opening **180** for ramp **18** to allow the ramp to be drawn snugly into an upright position against the outer surface of wall support **186**. Wall support **186** may have affixed thereto a fabric connector **190**. Connector **190** is clamped to wall support **186** such as by a retainer **192**. (See FIGS. **5A**, **6A** and **10**). Fabric connector **190** may have one fabric layer **194** or two fabric layers **194** and **196**. Layers **194** and **196** each have a connecting device, such as zipper **198**, which can be attached to a structure or structures **350** which may form a portico when the ramp is in a down or deployed condition as shown in FIGS. **8** and **10**. Layer **194** may be attached to, for example, a biological barrier, while layer **196** may be attached to, for example, an environmental barrier. When ramp **18** is in an upright position, connector **190** may be rolled up and stowed using straps **200**.

[0067] In another embodiment, a structure forming a portico **350** may be provided. Portico **350** may be formed of two layers. For example, one layer may form an environmental barrier and another layer may form a biological barrier. Each layer may be selectively attached by a connecting device, such as zipper **356**, to a connecting device, such as zipper **198**, on a respective layer **194** or **196**. Other known connecting devices such as VELCRO® hook and loop fasteners, snaps or the like may be used. Portico **350** may be of any desired structure. In one embodiment, air beams (not shown) are used to support the portico structure. Any type of conventional air beam may be used. Air beams typically are tubes of fabric or plastic or the like which are inflated and have a pre-configured shape to provide structural support. Portico **350** may have a door **352**, such as a fabric door, at an end spaced from opening **180**. Door **352** may be opened or closed using zippers **354**. Rings **212**, such as D-rings, may be provided on ramp **18**, and strap **358** along the bottom and side edges of portico **350** may be tied to rings **212** or the like on the ramp **18** to hold the portico in position. Portico **350** may be stowed within section **12** when shelter **10** is in a collapsed condition and ramp **18** is upright.

[0068] When ramp **18** is in a down or deployed condition, it may be supported by stabilizers, such as the two stabilizers **216** shown in FIG. **7**. Stabilizers **216** are conventional stabilizers which are affixed to the end of ramp **18** in a conventional manner to support ramp **18**. Stabilizers **216** typically have enlarged feet. Stabilizers **216** may be adjusted by the use of spring loaded ratchets to different heights to accommodate an uneven ground surface, and to provide the desired spacing between the end of ramp **18** and the underlying ground.

[0069] As shown in FIG. **11**, ramp **18** may be raised and lowered by use of a winch **320** which may be either manually operated or motor-driven. Typically, winch **320** is attached to a corner post **20** by rails **322**. A pulley arm **334** may be attached to post **20** by hook **336** that passes through a hole **56** in corner block **50**. The pulley arm **334** is aligned within guide blocks **338**. A clamping member **340** may be attached to post **20** through a flange on pulley arm **334** by use of a screw together with a threaded hole on post **20**. A spool **326** on winch **320** may reel cable **328** out through rollers **330** and through pulley **332** on arm **334**. A snap hook **342** on the end of cable **328** may be attached to a ring **210** on the exterior of the ramp **18**. To lower ramp **18**, handles **146** are removed from clamps **147** and the locking bars **140** are released by turning handles **146**. Cam **142** is then withdrawn from receiver **144**. Ramp **18** then can be lowered by winch **320**, using crank arm **324**, if manually operated. As the ramp **18** approaches ground level, stabilizers **216** may be attached to the end of the ramp by inserting pins **218** through holes **214**. The stabilizers **216** are urged upwardly against the end of ramp **18** to provide a solid support independent of the winch **320** and cable **328**.

[0070] In another embodiment, as shown in FIGS. **12-15**, a transition panel **230** may be attached to the end of ramp **18**. Panel **230** provides a smooth transition from ground level to ramp **18** or from ramp **18** to another ramp or the like. Panel **230** allows wheeled vehicles and the like to be rolled onto or off ramp **18**. Typically, panel **230** is segmented as shown in FIGS. **12** and **13** to accommodate any unevenness in the ground. That is, panel **230** is comprised of hinged segments or fingers **244**. Fingers **244** may be spaced from one another by small gaps, or they may be immediately adjacent one another.

[0071] Preferably, panel **230** extends across the width of ramp **18**. In one embodiment, panel **230** is attached to sections **232** and **234**, which may be angled structures for strength. Holes **236** in sections **232** and **234** may pass over posts **218** on stabilizers **216**. A locking sleeve retainer **220** may pass over posts **218** to lock the panel **230**, ramp **18** and stabilizers **216** together as shown in FIGS. **7**, **11** and **12**. It is understood, of course, that panel **230** may be attached in other ways to ramp **18** and that this embodiment illustrates only one possible way of attachment.

[0072] When panel **230** is stored, sections **232** and **234** may be folded together so that panel **230** can be inserted within the interior of shelter **10**. In one embodiment, sections **232** and **234** are connected together by hinge **238**. During storage, a storage fixture, such as a pin **224** may be inserted through holes **236** in sections **232** and **234** and a locking sleeve **220** may be attached at one end of pin **224**.

[0073] Each of fingers **244** may be attached to a sealed tubing spacer **240** by an associated hinge **242**. In one embodiment, tubing spacers **240** are welded or otherwise attached to the front of sections **232** and **234**. Fingers **244** may be tapered at the end attached to hinges **242** and also at a second end **248**. Each finger **244** floats or moves independently of the other fingers **244**. Fingers **244** additionally may each have downwardly bent tabs **250** that have holes **252**. Fingers **244** typically are joined together on their underside by a rod or rods **254** which pass through holes **252** in tabs **250**. A pin **256** may be inserted in each end of rod **254** to prevent movement of rod **254**. The holes **252** are oversized to allow a certain amount of sliding movement of rod **254**. This arrangement permits a predetermined amount of individual movement of the fingers **244** with respect to one another. This flexibility or movement



is illustrated in FIGS. 14 and 15. Each finger 244 may rotate about axis 258 by an angle equal to about 30° above and below a median position.

[0074] Typically, each panel, such as panel 62, wall 64, wall 66, wall 68, panel 82, wall 84, wall 86, wall 88, ramp 18, ceiling 70 and ceiling 90, is formed of a structural panel 130 as illustrated in FIG. 2A. Each panel 130 may include a framework of tubing 132 with a honeycomb support 134 filling the voids. The honeycomb support may be formed of any type of material, such as a polymer. One example is NOMEX™. Insulation material may be inserted into the honeycomb support 134. A sheet metal skin 136, such as an aluminum skin, typically covers this structure.

[0075] When in a retracted or collapsed configuration as shown in FIG. 2, the corner posts 20 provide bearing members which support loads above shelter 10 and provide the necessary strength to allow the shelters 10 to comply with ISO 1496/1. Also, loads are transferred from frame members 17 to frame members 15 through locking bars 140 by way of panels 62 and 82. At end 16, wall support 186 provides load support as well as locking bars 140, through ramp 18. At ends 14 and 16, upper frame supports 21 and lower frame supports 23 provide load bearing support. To comply with the racking requirements of ISO 1496/1, typically four equally-spaced locking bars 140 are used for each panel 62 and 82. Wall support 186 also helps maintain the required rigidity, as do frame supports 21 and 23.

[0076] First end wall 154 may be provided with a power and communications panel 164 which typically is flush with wall 154. A leveling bubble may also be provided for manual leveling of the shelter 10. Preferably, however, the shelter is self-leveling. A self-leveling control panel 168 allows the shelter to level itself through the use of built-in sensors and software. Control panel 168 may be in any suitable location, such as on the inside surface of wall 154. A typical self leveling unit employs an inclinometer and electric motors and gear reducers to operate rams 24 of jacks 22 in a known manner to level shelter 10. One exemplary, suitable self-leveling unit is leveling support model 287A, manufactured by Hetek Hebeteknik GmbH, Treffurt, linter den Linden, Germany.

[0077] Power may be provided by line 400 to connector 402 (FIG. 3) from a source, such as a peripheral mechanical module to power communications panel 164. Heating, ventilation and air conditioning may be provided through supply and return ducts 406 and 408 (FIG. 8) which may connect to adapter plates 410 and 412, respectively, in complexing panel 414 (FIG. 4), when the shelter is in an expanded condition. Communication lines (not shown) may connect with connectors 404 on panel 164. Clean and waste water lines 416 and 418, respectively, (FIG. 8) may be connected to adapter plate 420 which is interchangeable with other adapter plates at port 422 in wall 86. (FIGS. 6A and 9). Panel 164 may be integrated with internal panel 166. Power from panel 166 may be supplied to panel 167 to supply power to outlet strips (not shown) and lights 150. Power from panel 166 may also be supplied to panel 168.

[0078] It should be appreciated that various embodiments may be formed with one or more of the above-described features. The above aspects and features may be employed in any suitable combination as the present invention is not limited in this respect. It should also be appreciated that the drawings illustrate various components and features which may be incorporated into various embodiments. For simpli-

fication, some of the drawings may illustrate more than one optional feature of the feature or component. However, the invention is not limited to the specific embodiments disclosed in the drawings. It should be recognized that the invention encompasses embodiments which may include only a portion of the components illustrated in any one drawing figure, and/or may also encompass embodiments combining components illustrated in multiple different drawing figures.

[0079] It should be understood that the foregoing description of various embodiments is intended merely to be illustrative thereof and that other embodiments, modifications, and equivalents are within the scope of the invention recited in the claims appended hereto.

What is claimed is:

1. An expandable shelter having an expanded configuration and a collapsed configuration in which the shelter has the approximate dimensions of a standard International Organization for Standardization (ISO) freight container, the shelter comprising:

first and second substantially parallel corner posts disposed at a first end of the shelter, the first and second corner posts having first and second ends;  
an upper frame support extending between the first ends of the first and second corner posts;  
a lower frame support extending between the second ends of the first and second corner posts;  
a wall support attached to the first and second corner posts and the upper frame support; and  
a displaceable panel hinged at the first end of the shelter and configured to fit securely on the interior of the first and second corner posts when in a closed configuration in which the displaced panel is disposed between the first and second corner posts,

wherein the shelter has sufficient strength to withstand the forces of at least eight similar shelters stacked on top of the shelter.

2. The expandable shelter of claim 1, further comprising: one or more locking bars operable on a surface of the upper frame support, each comprising a cam configured to be inserted into a respective one of one or more receivers when the displaceable panel is in the closed configuration, wherein the displaceable panel and the one or more locking bars are configured to transfer forces from the upper frame support to the lower frame support when the one or more cams are disposed in the one or more receivers.

3. The expandable shelter of claim 1, wherein the shelter, in the collapsed configuration, is configured to satisfy the stacking test requirements when at least eight similarly dimensioned shelter are stacked on top of the shelter.

4. The expandable shelter of claim 1, wherein each of the corner posts comprises first and second connection blocks disposed adjacent the first and second ends of the corner post.

5. The expandable shelter of claim 1, wherein at least one of the corner posts comprises an interior cavity configured to receive a jack configured to assist with leveling the shelter.

6. The expandable shelter of claim 1, further comprising: a jack configured to assist with leveling the shelter; and a hinge connecting the jack and one of the corner posts, wherein the hinge is configured to allow the jack to pivot from a first position in which the jack is disposed substantially within an interior cavity of the one of the corner posts to a second position in which the jack is disposed outside of the one of the corner posts.



7. The expandable shelter of claim 6, wherein a longitudinal axis of the jack is substantially parallel with a longitudinal axis of the one of the corner posts in both the first and second positions.

8. The expandable shelter of claim 1, wherein each of the corner posts comprises an interior cavity configured to receive a jack configured to assist with leveling the shelter.

9. An expandable shelter having an expanded configuration and a collapsed configuration in which the shelter has the approximate dimensions of a standard International Organization for Standardization (ISO) freight container, the shelter comprising:

first and second substantially parallel corner posts disposed at a first end of the shelter; and

a ramp coupled with hinges at the first end of the shelter and configured to fit securely on the interior of the first and second corner posts when in a closed configuration in which the ramp is disposed between the first and second corner posts,

wherein the shelter has sufficient strength to withstand the forces of at least eight similar shelters stacked on top of the shelter.

10. The expandable shelter of claim 9, wherein the first and second substantially parallel corner posts have first and second ends.

11. The expandable shelter of claim 10, further comprising: an upper frame support extending between the first ends of the first and second corner posts;

a lower frame support extending between the second ends of the first and second corner posts; and

a wall support attached to the first and second corner posts and the upper frame support.

12. The expandable shelter of claim 11, further comprising: one or more locking bars operable on a surface of the upper frame support, each comprising a cam configured to be inserted into a respective one of one or more receivers when the ramp is in the closed configuration, wherein the ramp and the one or more locking bars are configured to transfer forces from the upper frame support to the lower frame support when the one or more cams are disposed in the one or more receivers.

13. The expandable shelter of claim 11, wherein each of the corner posts comprises first and second connection blocks disposed adjacent the first and second ends of the corner post.

14. An expandable shelter having an expanded configuration and a collapsed configuration in which the shelter has the

approximate dimensions of a standard International Organization for Standardization (ISO) freight container, the shelter comprising:

first and second substantially parallel corner posts disposed at a first end of the shelter, the first and second corner posts having first and second ends;

an upper frame support extending between the first ends of the first and second corner posts;

a lower frame support extending between the second ends of the first and second corner posts;

a wall support attached to the first and second corner posts and the upper frame support;

a fabric connector connected to the wall support; and

a displaceable panel hinged at the first end of the shelter and configured to fit securely on the interior of the first and second corner posts when in a closed configuration in which the displaced panel is disposed between the first and second corner posts,

wherein the shelter has sufficient strength to withstand the forces of at least eight similar shelters stacked on top of the shelter.

15. The expandable shelter of claim 14, wherein the fabric connector comprises a fabric clamp that extends around the perimeter of the wall support.

16. The expandable shelter of claim 15, wherein the fabric connector comprises at least a first layer of fabric, the at least first layer of fabric being mounted in the fabric clamp.

17. The expandable shelter of claim 14, further comprising:

one or more locking bars operable on a surface of the upper frame support, each comprising a cam configured to be inserted into a respective one of one or more receivers when the displaceable panel is in the closed configuration, wherein the displaceable panel and the one or more locking bars are configured to transfer forces from the upper frame support to the lower frame support when the one or more cams are disposed in the one or more receivers.

18. The expandable shelter of claim 14, wherein each of the corner posts comprises first and second connection blocks disposed adjacent the first and second ends of the corner post.

\* \* \* \* \*