



US 20110247519A1

(19) **United States**

(12) **Patent Application Publication**
Studer

(10) **Pub. No.: US 2011/0247519 A1**

(43) **Pub. Date: Oct. 13, 2011**

(54) **MAGNETIC SUSPENSION SYSTEM WITH INTEGRABLE PROPULSION**

Publication Classification

(75) Inventor: **Phillip A. Studer**, Silver Spring, MD (US)

(51) **Int. Cl.**
B60L 13/06 (2006.01)
B60L 13/04 (2006.01)

(73) Assignees: **Philip Albert Studer**, Silver Spring, MD (US); **Sandor Wayne Shapery**, San Diego, CA (US)

(52) **U.S. Cl.** **104/284; 104/281**

(21) Appl. No.: **13/164,201**

(57) **ABSTRACT**

(22) Filed: **Jun. 20, 2011**

A method and system for magnetically levitating a load is disclosed. One embodiment of the invention is a system for magnetically levitating a load, the system comprising at least two lift generators, each comprising a source of magnetic flux configured to induce a magnetic flux in a rail via a leg on either side of the rail, at least one magnetically permeable beam connecting the lift generators, and control circuitry configured to generate and modulate a magnetic current flux through the crossbeam so as to maintain gaps between the legs and rail, wherein the gaps defined by the legs on either side of the rail are of unequal size.

Related U.S. Application Data

(63) Continuation of application No. 12/048,062, filed on Mar. 13, 2008, now Pat. No. 7,963,228.

(60) Provisional application No. 60/906,554, filed on Mar. 13, 2007.

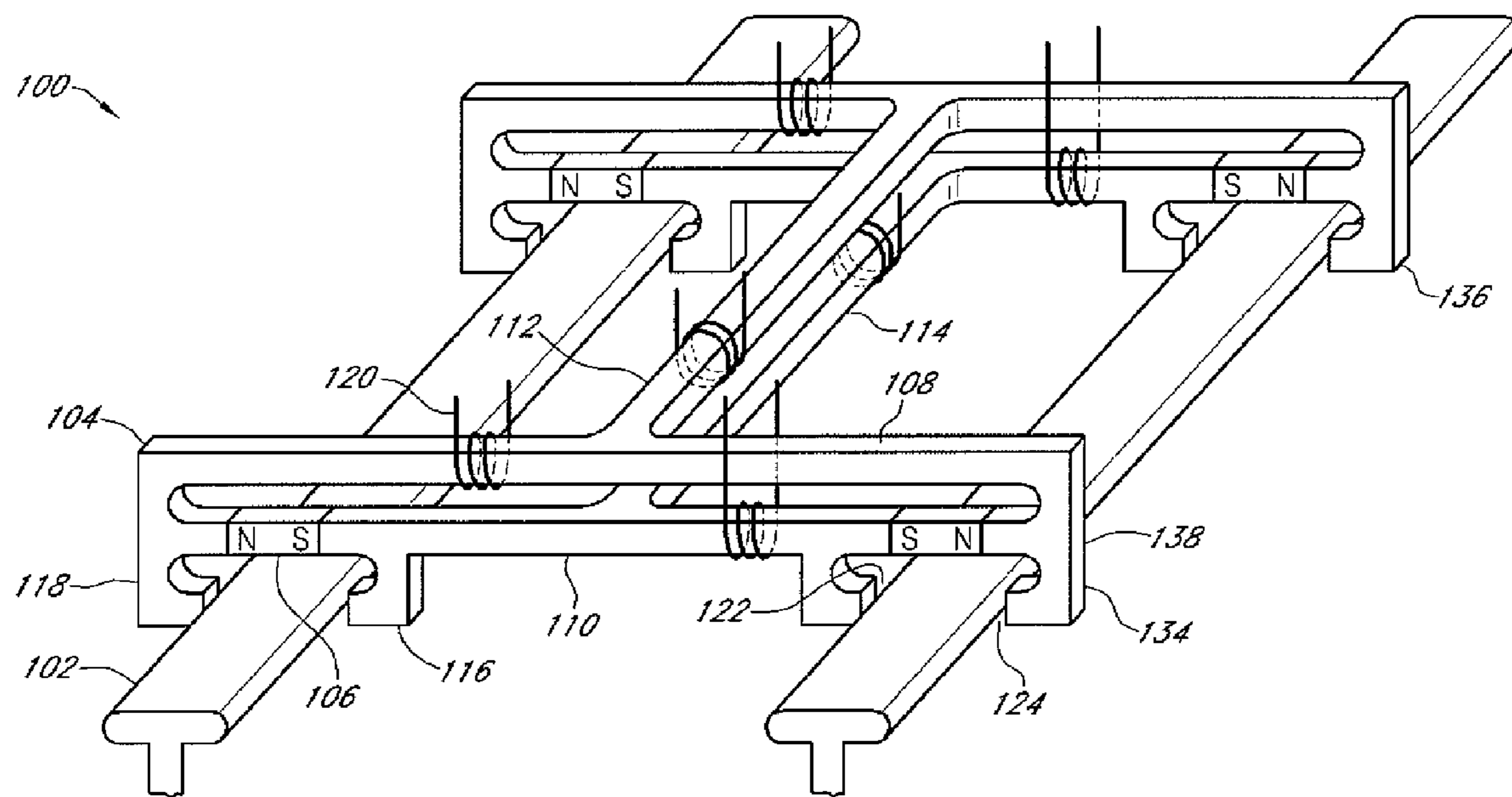

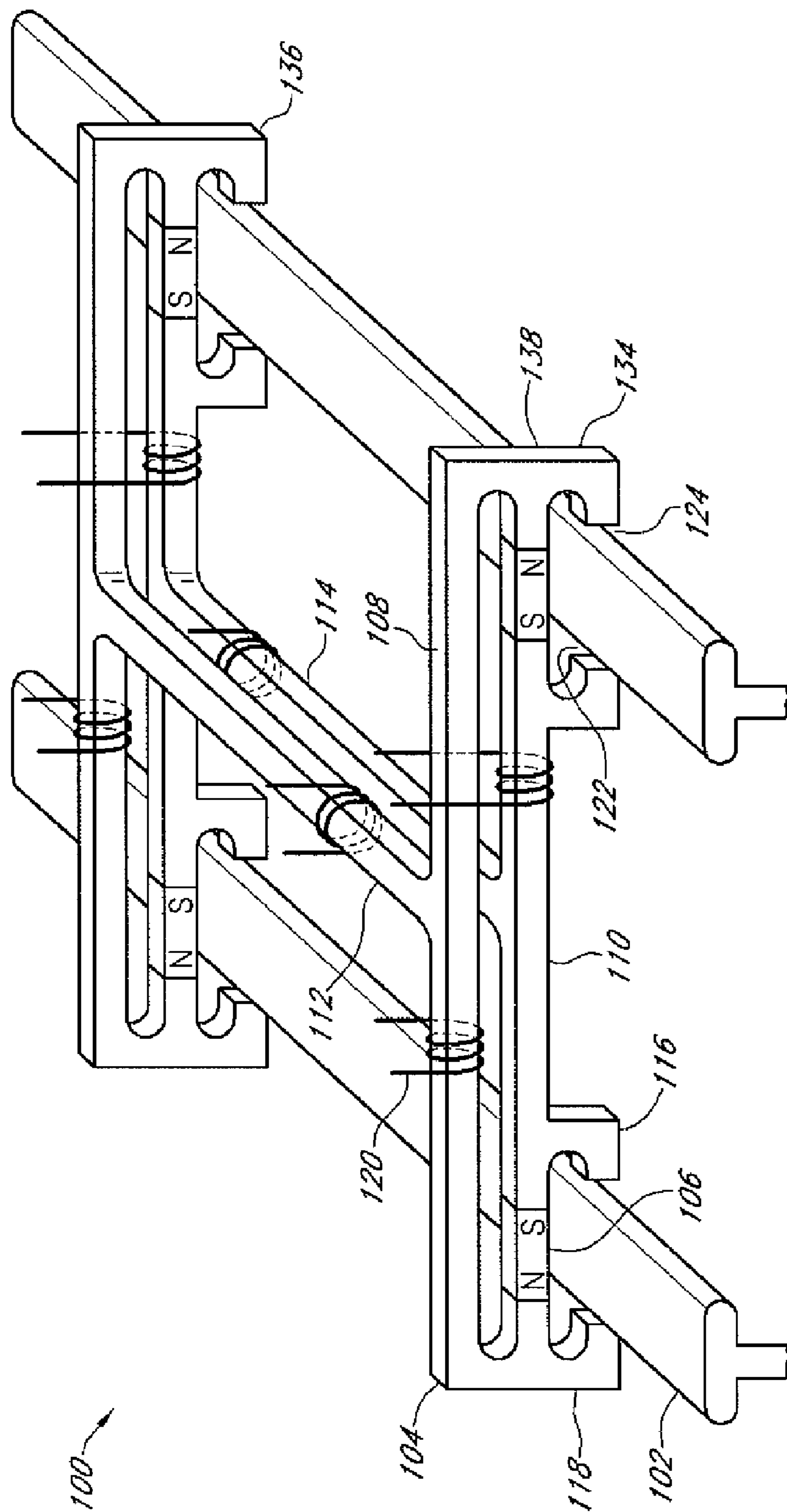

FIG. 1

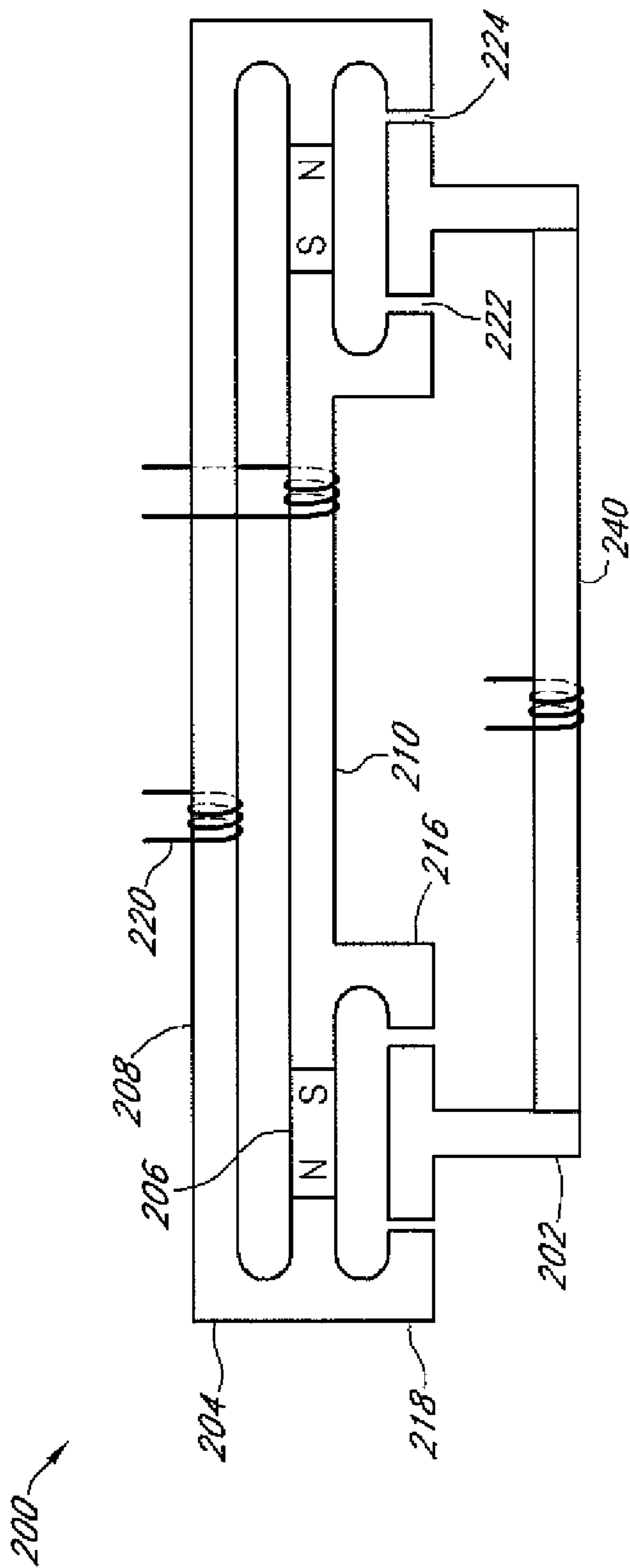

FIG. 2

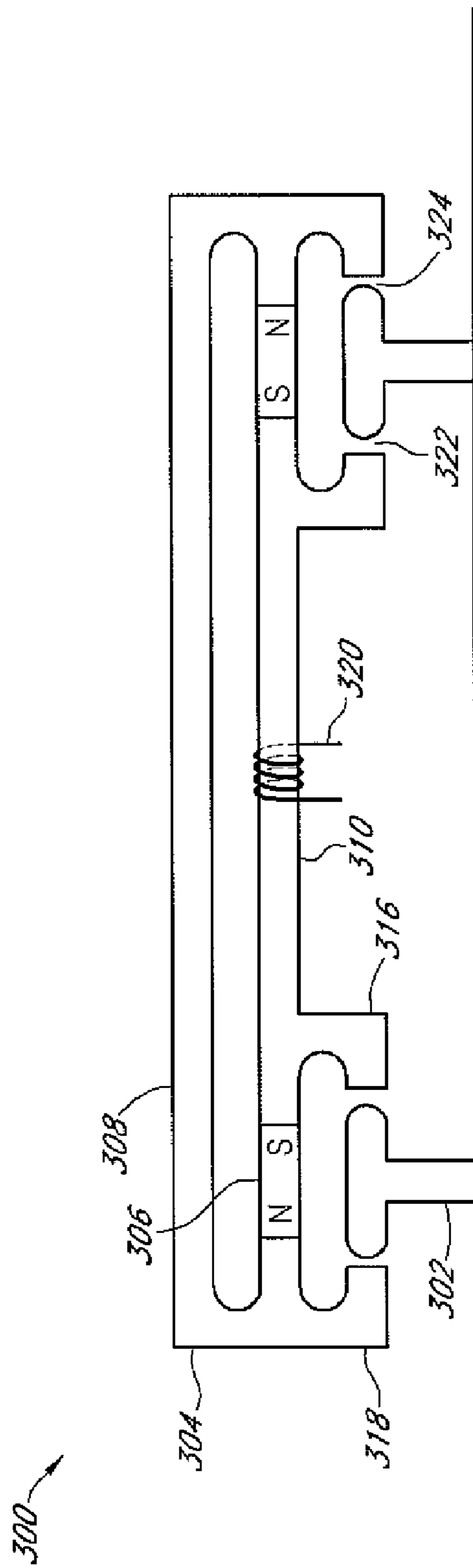

FIG. 3

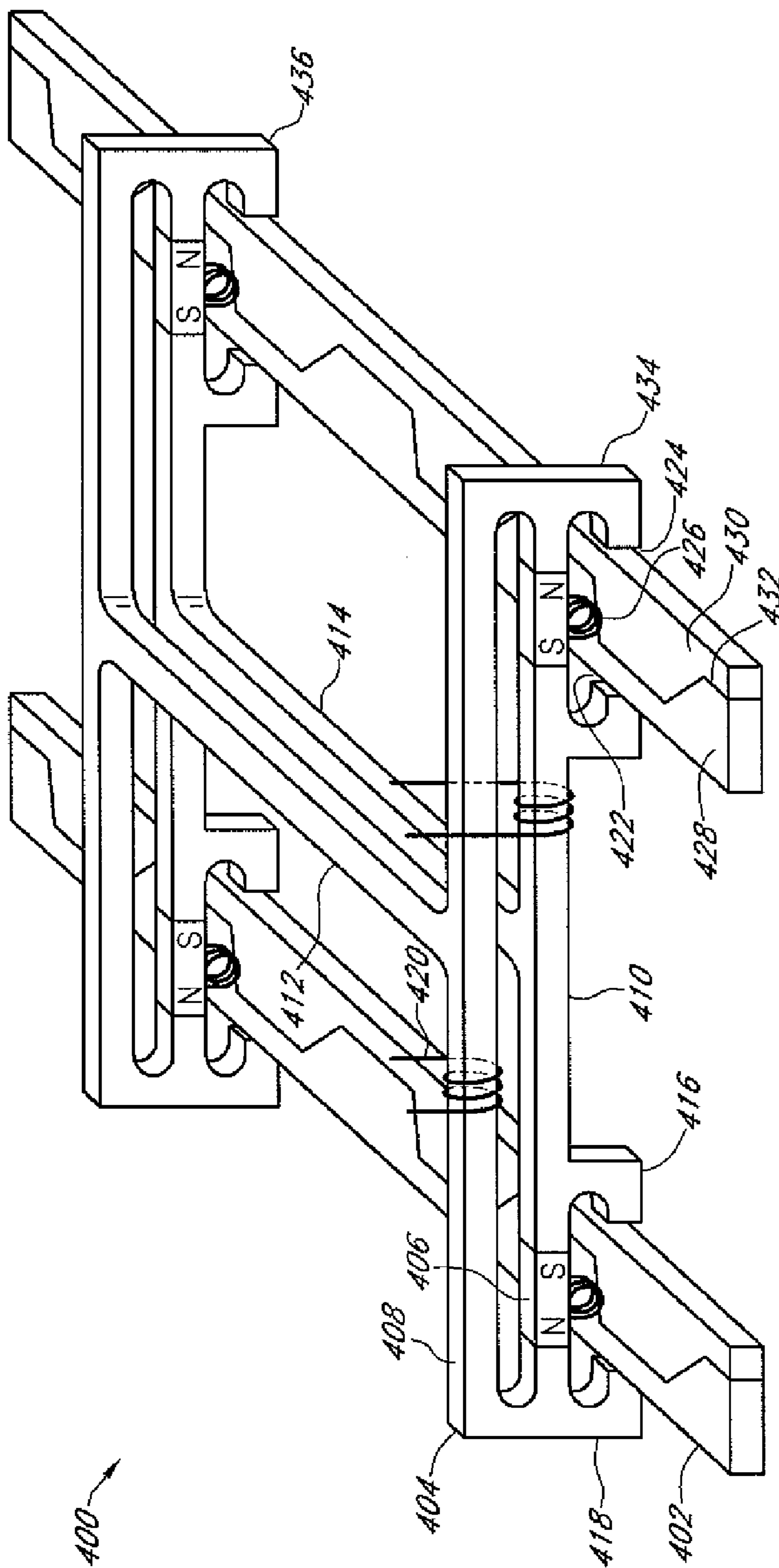

FIG. 4

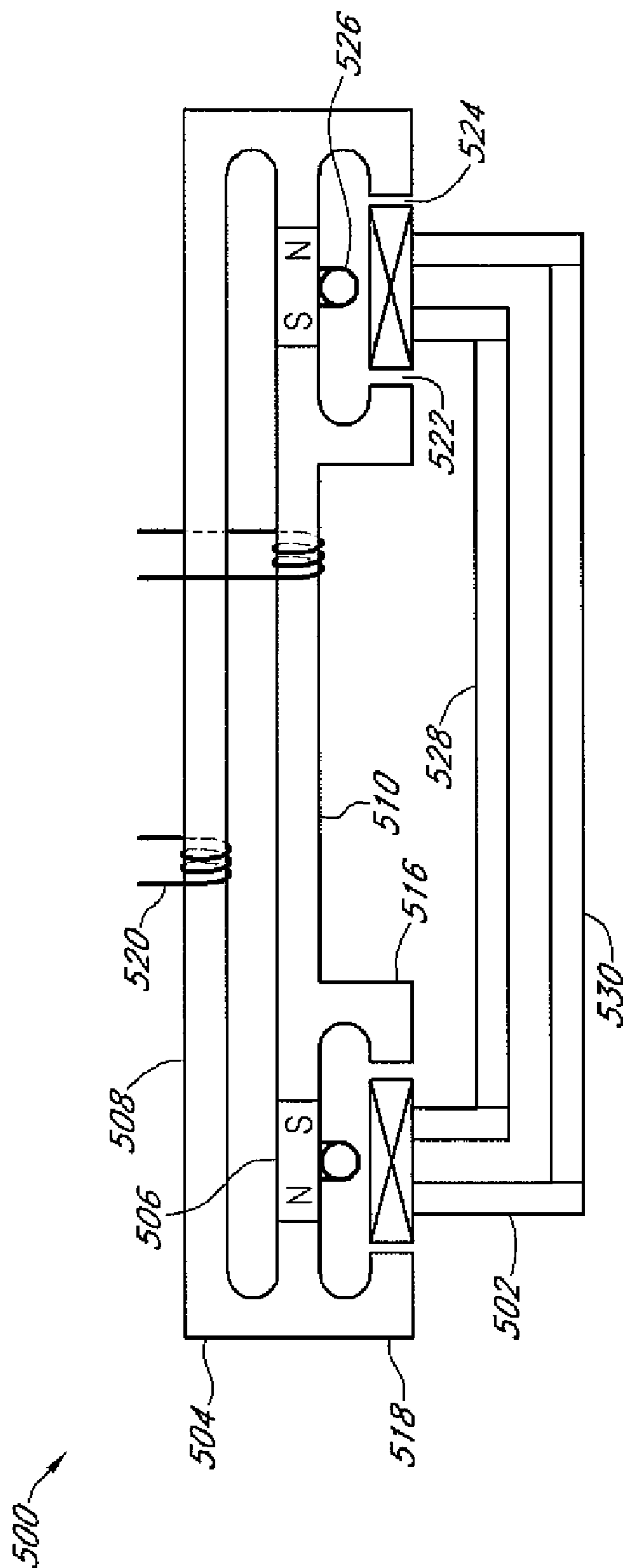

FIG. 5

MAGNETIC SUSPENSION SYSTEM WITH INTEGRABLE PROPULSION

CROSS-REFERENCE TO RELATED APPLICATIONS

[0001] This application claims the benefit of the earlier filing date under 35 U.S.C. §120 of co-pending U.S. patent application Ser. No. 12/048062, filed Mar. 13, 2008, which claims priority under 35 U.S.C. §119(e) to U.S. Provisional Application No. 60/906554 filed Mar. 13, 2007, which are both hereby incorporated by reference in their entireties.

BACKGROUND OF THE INVENTION

[0002] 1. Field of the Invention

[0003] The present invention relates to magnetic suspension systems, and in particular, magnetic suspension systems with integrable propulsion.

[0004] 2. Description of the Related Art

[0005] Levitation systems using permanent magnets have been used as a form of transportation that suspends, guides, and propel vehicles (predominantly trains) using an electromagnetic force to counteract the effects of the gravitational force. Improvements to these systems may enable high speeds without the typical problems of mechanical wear, thermal inefficiency, and noise, as well as other issues prevalent in such systems.

SUMMARY OF CERTAIN INVENTIVE ASPECTS

[0006] The systems and methods of the invention each have several aspects, no single one of which is solely responsible for its desirable attributes. Without limiting the scope of this invention as expressed by the claims which follow, its more prominent features will now be discussed briefly. After considering this discussion, and particularly after reading the section entitled "Detailed Description of Certain Inventive Embodiments" one will understand how the sample features of this invention provide advantages to magnetic suspension systems with integrable propulsion.

[0007] One aspect of the invention is a system for magnetically levitating a load, the system comprising at least two lift generators, each comprising a source of magnetic flux configured to induce a magnetic flux in a rail via a leg on either side of the rail, at least one magnetically permeable beam connecting the lift generators, and control circuitry configured to generate a magnetic flux through the beam so as to maintain gaps between the legs and rail.

[0008] Another aspect of the invention is a method of magnetically levitating a load, the method comprising positioning a first source of magnetic flux proximal to a first rail, thereby inducing a first magnetic flux in the first rail, positioning a second source of magnetic flux proximal to a second rail, thereby inducing a second magnetic flux in a second rail, and manipulating the magnetic current in a magnetically permeable beam connecting the first source of magnetic flux to the second source of magnetic flux.

[0009] Another aspect of the invention is a rail system for magnetically levitating a platform, the rail system comprising a first rail, a second rail oriented substantially parallel to the first rail, at least one magnetically permeable beam connecting the first and second rail, and control circuitry configured to generate a magnetic flux through the beam so as to maintain gaps between the legs of a platform and at least one of the first

and second rail, wherein the gaps defined by the legs on either side of the rail are of unequal size.

BRIEF DESCRIPTION OF THE DRAWINGS

[0010] FIG. 1 is an embodiment of a levitating rail system, wherein the frame comprises two platforms.

[0011] FIG. 2 is a cross-section of one embodiment of a platform.

[0012] FIG. 3 is a cross-section of another embodiment of a platform.

[0013] FIG. 4 is an embodiment of a levitating rail system with an integrated propulsion system.

[0014] FIG. 5 is cross-section of one embodiment of a levitating platform with an integrated propulsion system.

DETAILED DESCRIPTION OF CERTAIN EMBODIMENTS

[0015] The following detailed description of certain embodiments presents various descriptions of specific embodiments of the present invention. However, the present invention can be embodied in a multitude of different ways as defined and covered by the claims. In this description, reference is made to the drawings wherein like parts are designated with like numerals throughout.

[0016] FIG. 1 is an embodiment of a levitating rail system, wherein the frame comprises two platforms. The system 100 comprises a frame 104 situated over a pair of rails 102. The rails 102 may be specially-designed as part of the system 100 or may be conventional steel rails as used with most railroad tracks. The frame 104 comprises a front platform 134 and a rear platform 136 connected by an upper axial crossbar 112 and lower axial crossbar 114. In other embodiments of the system, fewer or a greater number of platforms may be used. In still other embodiments, there may be fewer or a greater number of axial crossbars connecting each platform. Upon the frame 104, one may place a load, which is to be suspended above the tracks. The load may be, for example, a passenger railcar, a shipping container, or any of a number of things. The load may also be the frame 104 itself. The system 100 is designed such that the addition of a sizable load does not inhibit the levitating capabilities of the frame 104 over the rails 102. In an embodiment of the system, the frame 104 does not contact rails 102. This configuration has the benefit of reducing certain effects caused by friction including wear on the mechanical parts, excess generated heat, and noise. In other embodiments, the frame 104 does contact the rails. Such contact may be incidental or may further serve to improve balance and control of the frame. In some embodiments, a propulsion system may be configured to contact the rails to provide forward motion while the load-bearing components are magnetically-levitated.

[0017] Each platform comprises two lift generators 138 connected by an upper horizontal crossbar 108 and lower horizontal crossbar 110. In some embodiments of the system, fewer or a greater number of lift generators may be used. In still other embodiments, there may be fewer or greater number of horizontal crossbars connecting each lift generator. The lift generator 138 functions in much the same way as the spring and wheel of a car, in providing the weight-bearing functionality of the system. The lift generator 138 comprises a magnet 106, an inner leg 116, and an outer leg 118. The lift generator 138 is positioned such that the magnet is generally over the rail 102, and each of the legs straddle the rail 102,

thereby defining an inner rail gap **122** between the inner leg **116** and the rail and an outer rail gap **124** between the outer leg **118** and the rail. In other embodiments, the magnet **106** may not be placed directly over the rail. For example, the magnet **106** may be embodied in either the inner leg **116** or outer leg **118**. In still other embodiments, there may be a plurality of magnets in each lift generator. The magnet **106** may be a permanent magnet, an electromagnet, or a combination of both. The magnet **106** may be a permanent magnet using an alloy of rare earth elements. For example, the magnet **106** may be a neodymium magnet or a samarium-cobalt magnet. Neodymium magnets have the advantages of being both affordable and having a strong magnetic field.

[0018] Each lift generator **138** performs its function using the forces of magnetic attraction. The magnet **106** magnetizes the inner leg **116** and outer leg **118** with opposite polarity. Both the inner leg **116** and outer leg **118** are attracted to the rail **102**. This attraction prevents the frame **104** from lowering. Explained another way, the lift generator **138** creates a closed magnetic loop. As described in relation to the left front lift generator, the magnetic flux flows from the north pole of the magnet **106**, down the outer leg **118**, across the outer rail gap **124**, through the rail **102**, across the inner rail gap **122**, up the inner leg **116**, and to the south pole of the magnet **106**. Magnetic forces resist extension of this closed loop of magnetic current. Each lift generator of the frame **104** operates using similar principles. The inner rail gap **112** and outer rail gap **124** may be designed to have unequal size, as described in more detail below.

[0019] As mentioned, the left and right lift generators are connected by one or more horizontal crossbars **108**, **110**. The connection of the lift generators **138** provides lateral control capability to the system. Additionally, control coils **120** may be placed on any of the crossbars to influence and control the dynamics of the system. By generating an electric current through one of the control coils **120**, a magnetic flux is induced in the crossbar to which the control coil **120** is attached. A control coil **120** may be placed on the upper horizontal crossbar **108**, lower horizontal crossbar **110**, upper axial crossbar **112**, lower axial crossbar **114**, inner leg **116**, or outer leg **118**. In some embodiments of the system, there is only one control coil **120**. In other embodiments of the system, there is more than one control coil **120**. In still other embodiments of the system, there is more than one control coil **120** placed on the same crossbar. A control coil **120** may be placed upon the lower horizontal crossbar **110** to produce forces in the horizontal direction. The electric current through the control coil **120** may be controlled by a sensor such that the frame **104** remains centered on the track. This may be enabled by magnetically connecting the rails **102** with a rail crossbar as will be described later with respect to FIG. 2. Thus, in some embodiments, a control coil **120** may comprise a coil of wire, wrapped around a part of the frame **104**, a sensor to determine the need for electric current through the wire, a computing module to compute how much electric current to generate through the wire, and/or an electric current source to generate the electric current through the wire. A control coil **120** placed upon the lower axial crossbar **114** between the front platform **134** and the rear platform **136** could be employed to compensate for rail permeability variations at different points on the rails **102**, thereby reducing mechanical strain on the frame **104**. Additionally, a control coil **120** placed upon the lower axial crossbar **114** could be used to differentially change the amount of lift generated by the front

platform **134** relative to the rear platform **136** to affect the pitch of the system or to balance an uneven load. Control coils **120** may also be placed upon the inner leg **116** and outer leg **118** of a lift generator **134** to differentially affect the roll of each lift generator **134** to balance a load or reduce mechanical strain on the system.

[0020] FIG. 2 is a cross-section of one embodiment of a platform. The platform **234** comprises two lift generators **238** connected by an upper horizontal crossbar **208** and a lower horizontal crossbar **210**. Each lift generator comprises a magnet **206**, an inner leg **216**, and an outer leg **218**. The platform **234** is situated over a rail **202** thereby defining, for each lift generator **238**, an inner rail gap **222** and an outer rail gap **224**. In this embodiment, the rail(s) **202** are connected horizontally by a rail crossbar **240**. Control coils **220** are placed on the upper horizontal crossbar **208**, the lower horizontal crossbar **210**, and the rail crossbar **240**. In this embodiment, the inner rail gap **222** and outer rail gap **224** are of a different size. In this configuration, only one of the four shown legs **216**, **218** can contact the rail **202** at any one time. If the inner rail gap **222** and outer rail gap **224** were of equal size, then two of the four shown legs could contact the rail simultaneously, thereby completing a magnetic current between the two lift generators **238** through the rail **202**. Lateral control in this embodiment is produced by the electromagnetic flux of the control coil **220** passing through both inter gaps **222** and/or both outer gaps **224**. Magnetic current (and flux) in either direction adds to the flux of the magnet **206** on one side and subtracts from the flux of the magnet **206** on the opposite side, as the two magnets are oppositely polarized. It is for this reason that a magnetic connection, e.g. via rail crossbar **240**, may be advantageously employed between the two rails **202**. The connections do not short out the magnets **206** because the permeable connection is between similar poles, i.e. north to north or south to south. Such a control technique has been referred to as permanent magnet bias control.

[0021] FIG. 3 is a cross-section of another embodiment of a platform lacking lateral control stability via a rail crossbar. In this embodiment, the platform **300** comprises two lift generators **338** connected by an upper horizontal crossbar **308** and a lower horizontal crossbar **310**. Each lift generator comprises a magnet **306**, an inner leg **316**, and an outer leg **318**. The platform **334** is situated over a set of rails **302** thereby defining, for each lift generator **338**, an inner rail gap **322** and an outer rail gap **324**. In this embodiment, the rails are magnetically separate. A single control coil **320** is located on the lower horizontal crossbar **310**. Using this configuration, it would be possible to construct a levitating rail system on conventional railroad tracks.

[0022] FIG. 4 is an embodiment of a levitating rail system with an integrated propulsion system. The system **400** comprises a frame **404** situated over a set of rails **402**. The rail **402** comprises an inner rail piece **428** and an outer rail piece **430** separated by a non-conductive separator **432**. The frame comprises a front platform **434** and a rear platform **436** connected by an upper axial crossbar **412** and lower axial crossbar **414**. In other embodiments of the system, fewer or a greater number of platforms may be used. In still other embodiments, there may be fewer or a greater number of axial crossbars connecting each platform. Upon the frame **404**, one may place a load, which is to be suspended above the tracks. In one embodiment of the system, the frame **404** does not contact the rails **402**. In other embodiments, the frame **104** does contact the rails.

[0023] Each platform comprises two lift generators **438** connected by an upper horizontal crossbar **408** and lower horizontal crossbar **410**. In some embodiments of the system, fewer or a greater number of lift generators may be used. In still other embodiments, there may be fewer or greater number of horizontal crossbars connecting each lift generator. The lift generator **438** comprises a magnet **406**, an inner leg **416**, an outer leg **418**, and an armature coil **426**. The lift generator **438** is positioned such that the magnet is generally over the rail **402**, and each of the legs straddle the rail **402**, thereby defining an inner rail gap **422** between the inner leg **416** and the rail and an outer rail gap **424** between the outer leg **418** and the rail. In other embodiments, the magnet **406** may not be placed directly over the rail. For example, the magnet **406** may be embodied in either the inner leg **416** or outer leg **418**. In still other embodiments, there may be a plurality of magnets in each lift generator. In one embodiment, the armature coil is connected to the lift generator proximal to the magnet **406** and located over the rail **402**. In other embodiments, the armature coil **426** may be embodied in a different location. The armature coil **426** may be embodied, for example, in either the inner leg **416** or outer leg **418**. The rail **402** may be positioned advantageously with respect to the armature coil **426**. The armature windings may be a multiphase coil with phases distributed axially such that a number of phases are equal in length to a pole pair in a DC motor. In some embodiments, the armature coil **426** may comprise a 3-phase coil.

[0024] In this system, the lift generator **438** performs two functions, generating lift to keep the frame levitating above the rail **402**, and generating propulsive force through the use of the armature coil **426**. In some embodiments, the lift generator **438** may also produce guiding forces to center the yoke legs on the rail with clearance for non-contacting operation. The lift generator **438** generates lift, as described with respect to FIG. 1, using the forces of magnetic attraction. The lift generator **438** creates a closed magnetic loop. As described in relation to the left front lift generator, a magnetic current flows from the north pole of the magnet **406**, down the outer leg **418**, across the outer rail gap **424**, through the rail **402**, across the inner rail gap **422**, up the inner leg **416**, and to the south pole of the magnet **406**. Magnetic forces resist extension of this closed loop of magnetic current. Each lift generator of the frame **404** operates using similar principles.

[0025] As stated above, the lift generators **438** also generate propulsive force through the use of the armature coil **426**. The magnet **406** induces a magnetic field in the inner leg **416**, the outer leg **418**, and the rail **402**. In this case, the rail comprises two pieces, an inner rail piece **428** and an outer rail piece **430**. The inner rail piece **428** and the outer rail piece **430** are induced with a magnetic field of opposite polarity. In one embodiment, the armature coil **426** comprises an electromagnet such as a multiphase coil axially distributed such that armature currents react with rail poles to produce force in the desired direction. As the armature coil **426** is, in some embodiments, an electromagnet, its polarity can be reversed by reversing the electric current. Propulsion is thus achieved by normal DC motor action. In some embodiments, the armature coil **428** may include commutation circuitry to coordinate the changing of polarity. In other embodiments, the commutation circuitry may be consolidated, such that one module controls the commutation of the armature coil **426** in each of the lift generators **438**.

[0026] The rails **402**, as shown in FIG. 4, comprise an inner rail piece **428**, an identical but shifted outer rail piece **430**, and

a non-conductive separator **432**. This is not the only envisioned rail configuration. The inner rail piece **428** and outer rail piece **430** may be, for example, not identical. The inner rail piece **428** may comprise more material than the outer rail piece **430**. As described above, the magnet **406** induces magnetic fields having opposite polarity in the inner rail piece **428** and outer rail piece **430**. The passing frame **404** sees the rails as a series of alternating north and south poles. The pole spacing may be configured to facilitate propulsion based on the length of the armature coil **426**, which may be related to the axial length of the front or rear platform **434**, **436**.

[0027] As was described with respect to FIG. 1 and FIG. 2, the left and right lift generators **438** of FIG. 4 are connected by one or more horizontal crossbars **408**, **410**. Control coils **420** may be placed on any of the crossbars to influence and control the dynamics of the system. A control coil **420** may be placed on the upper horizontal crossbar **408**, lower horizontal crossbar **410**, upper axial crossbar **412**, lower axial crossbar **414**, inner leg **416**, or outer leg **418**. In some embodiments of the system, there is only one control coil **420**. In other embodiments of the system, there is more than one control coil **420**. In still other embodiments of the system, there is more than one control coil **420** placed on the same crossbar. The electric current through the control coil **420** may be controlled by a sensor such that the frame **404** remains centered on the track. Thus, in some embodiments, a control coil **420** may comprise a coil of wire, wrapped around a part of the frame **404**, a sensor to determine the need for electric current through the wire, a computing module to compute how much electric current to generate through the wire, and/or an electric current source to generate the electric current through the wire. A control coil **420** placed upon the lower axial crossbar **414** between the front platform **434** and the rear platform **436** could be employed to compensate for differences in the rail permeability at different points on the rails **402**, thereby reducing mechanical strain on the frame **404**. Additionally, a control coil **420** placed upon the lower axial crossbar **414** could be used to differentially change the amount of lift generated by the front platform **434** relative to the rear platform **436** to effect the pitch of the system or to balance an uneven load. Control coils **420** may also be placed upon the inner leg **416** and outer leg **418** of a lift generator **434** to differentially affect the roll of each lift generator **434** to balance a load or reduce mechanical strain on the system. Although not shown, the system of FIG. 4 may also comprise rail crossbars magnetically connecting the inner and outer rail pieces respectively, as will be described below with respect to FIG. 5.

[0028] FIG. 5 is cross-section of one embodiment of a levitating platform with integrated propulsion means. The platform **534** comprises two lift generators **538** connected by an upper horizontal crossbar **508** and a lower horizontal crossbar **510**. Each lift generator comprises a magnet **506**, an inner leg **516**, an outer leg **518**, and an armature coil **526**. The platform **500** is situated over a rail **502** thereby defining, for each lift generator **538**, an inner rail gap **522** and an outer rail gap **524**. The rail **502** comprises an inner rail piece **528**, an outer rail piece **530**, and a non-conductive separator (not shown). In this embodiment, the inner rail pieces **528** are connected horizontally by rail crossbar **528** and similarly, the outer rail pieces **530** are connected horizontally by rail crossbar **530**. Control coils **220** are placed on the upper horizontal crossbar **508**, and the lower horizontal crossbar **510**. In this embodiment, the inner rail gap **522** and outer rail gap **524** are

of a different size. In this configuration, only one of the four shown legs **516**, **518** can contact the rail **502** at any one time.

[0029] It is to be understood that while a single propulsion method using magnetic forces was described, the levitating platform could be propelled using any of a number of propulsion methods well-known in the art. The platforms could, for example, be connected to a conventional, wheeled locomotive engine. The benefits of levitating platforms as opposed to wheeled carts are, among other things, the reduction of wear on mechanical parts, the reduction of extraneous heat produced, and the reduction of noise. Even a hybrid levitation/wheeled system has the potential to be more energy efficient than conventional systems. Still other wheeled or levitating propulsion means could be used.

[0030] While the above description has pointed out novel features of the invention as applied to various embodiments, the skilled person will understand that various omissions, substitutions, and changes in the form and details of the device or process illustrated may be made without departing from the scope of the invention. For example, although embodiments of the invention have been described with reference to uncompressed video data, those embodiments can be applied to compressed video data as well. Therefore, the scope of the invention is defined by the appended claims rather than by the foregoing description. All variations coming within the meaning and range of equivalency of the claims are embraced within their scope.

What is claimed is:

1. A method of magnetically levitating a load, the method comprising:

inducing a magnetic flux in a first rail of a track via a first leg spaced apart horizontally from a first side of the first rail and a second leg spaced apart horizontally from a second side of the first rail, wherein the first side of the first rail is opposite the second side of the first rail, and wherein a first gap is defined between the first leg and the first rail and a second gap is defined between the second leg and the first rail;

inducing a magnetic flux in a second rail of the track via a third leg spaced apart horizontally from a first side of the second rail and a fourth leg spaced apart horizontally from a second side of the second rail, wherein the first side of second rail is opposite the second side of the second rail, and wherein a third gap is defined between the third leg and the second rail and a fourth gap is defined between the fourth leg and the second rail; and varying a magnitude of a magnetic flux in at least one magnetically permeable beam connecting the first source of magnetic flux to the second source of magnetic flux, wherein the first gap and the second gap are of unequal size.

2. The method of claim **1**, wherein the first gap is larger than the second gap.

3. The method of claim **1**, further comprising varying a magnitude of an electric current through at least one conductive coil oriented in the same direction as the first rail to control the motion of first source of magnetic flux with respect to the first rail.

4. The method of claim **1**, further comprising sensing the position of at least one of the legs with respect to at least one of the rails.

5. The method of claim **1**, further comprising placing a load upon a frame coupled to the first source of magnetic flux and the second source of magnetic flux.

6. A system for magnetically levitating a load, the system comprising:

means for inducing a magnetic flux in a first rail via a first leg spaced apart horizontally from a first side of the first rail and a second leg spaced apart horizontally from a second side of the first rail, wherein the first side of the first rail is opposite the second side of the first rail, and wherein a first gap is defined between the first leg and the first rail and a second gap is defined between the second leg and the first rail;

means for inducing a magnetic flux in a second rail via a third leg spaced apart horizontally from a first side of the second rail and a fourth leg spaced apart horizontally from a second side of the second rail, wherein the first side of the second rail is opposite the second side of the second rail, and wherein a third gap is defined between the third leg and the second rail and a fourth gap is defined between the fourth leg and the second rail; and

means for varying a magnitude of a magnetic flux in at least one magnetically permeable beam connecting the means for inducing a magnetic flux in a first rail and the means for inducing a magnetic flux in a second rail, wherein the first gap and the second gap are of unequal size.

7. The system of claim **6**, wherein the means for inducing a magnetic flux in a first rail comprises a permanent magnet.

8. The system of claim **6**, further comprising means for varying a magnitude of an electric current through at least one conductive coil oriented in the same direction as the first rail to control the motion of the system with respect to the rails.

9. The system of claim **6**, further comprising means for sensing the position of at least one of the legs with respect to at least one of the rails.

10. The system of claim **6**, further comprising means for supporting a load above the means for inducing a magnetic flux in a first rail and the means for inducing a magnetic flux in a second rail.

11. A method of making a system for magnetically levitating a load, the method comprising:

providing a first source of magnetic flux configured to induce a magnetic flux in a first rail of a track via a first leg spaced apart horizontally from a first side of the first rail and a second leg spaced apart horizontally from a second side of the first rail, wherein the first side of the first rail is opposite the second side of the first rail, and wherein a first gap is defined between the first leg and the first rail and a second gap is defined between the second leg and the first rail;

providing a second source of magnetic flux configured to induce a magnetic flux in a second rail of the track via a third leg spaced apart horizontally from a first side of the second rail and a fourth leg spaced apart horizontally from a second side of the second rail, wherein the first side of second rail is opposite the second side of the second rail, and wherein a third gap is defined between the third leg and the second rail and a fourth gap is defined between the fourth leg and the second rail;

connecting the first source of magnetic flux and the second source of magnetic flux with at least one magnetically permeable beam; and

configuring control circuitry to vary a magnitude of a magnetic flux in the at least one magnetically permeable beam, wherein the first gap and the second gap are of unequal size.

12. The method of claim **11**, wherein the first source of magnetic flux comprises a permanent magnet.

13. The method of claim **11**, wherein the first gap is larger than the second gap.

14. The method of claim **11**, further comprising configuring propulsion circuitry to vary a magnitude of an electric current through at least one conductive coil oriented in the same direction as the first rail to control the motion of first source of magnetic flux with respect to the first rail.

15. The method of claim **11**, further comprising coupling a frame to the first source of magnetic flux and the second source of magnetic flux.

16. A system for magnetically levitating a load, the system comprising:

a first source of magnetic flux configured to induce a magnetic flux in a first rail of a track via a first leg spaced apart horizontally from a first side of the first rail and a second leg spaced apart horizontally from a second side of the first rail, wherein the first side of the first rail is opposite the second side of the first rail, and wherein a first gap is defined between the first leg and the first rail and a second gap is defined between the second leg and the first rail;

a second source of magnetic flux configured to induce a magnetic flux in a second rail of the track via a third leg spaced apart horizontally from a first side of the second

rail and a fourth leg spaced apart horizontally from a second side of the second rail, wherein the first side of second rail is opposite the second side of the second rail, and wherein a third gap is defined between the third leg and the second rail and a fourth gap is defined between the fourth leg and the second rail; and

control circuitry configured to vary a magnitude of a magnetic flux in at least one magnetically permeable beam connecting the first source of magnetic flux to the second source of magnetic flux, wherein the first gap and the second gap are of unequal size.

17. The system of claim **16**, wherein the first source of magnetic flux comprises a permanent magnet.

18. The system of claim **16**, further comprising propulsion circuitry configured to vary a magnitude of an electric current through at least one conductive coil oriented in the same direction as the first rail to control the motion of the system with respect to the rails.

19. The system of claim **16**, further comprising a sensor configured to sense the position of at least one of legs with respect to at least one of the rails.

20. The system of claim **16**, further comprising a frame configured to support a load, wherein the frame is coupled to the first source of magnetic flux and the second source of magnetic flux.

* * * * *