



US 20110244085A1

(19) **United States**

(12) **Patent Application Publication**  
**Crump et al.**

(10) **Pub. No.: US 2011/0244085 A1**

(43) **Pub. Date: Oct. 6, 2011**

(54) **OXYGEN, WATER VAPOR, AND CARBON DIOXIDE ABSORPTION IN A SINGLE USE CONTAINER**

**Related U.S. Application Data**

(63) Continuation-in-part of application No. 12/984,230, filed on Jan. 4, 2011, which is a continuation-in-part of application No. 12/751,583, filed on Mar. 31, 2010.

(75) Inventors: **John W. Crump**, Buffalo, NY (US); **Chieh-Chun Chau**, Victor, NY (US); **George E. McKedy**, Williamsville, NY (US); **David S. Payne**, West Seneca, NY (US); **Thomas H. Powers**, Mayville, NY (US); **Stanislav E. Solovyov**, Getzville, NY (US); **Thomas J. Hurley**, Kenmore, NY (US)

**Publication Classification**

(51) **Int. Cl.**  
**B65D 81/18** (2006.01)  
(52) **U.S. Cl.** ..... **426/118**

(73) Assignee: **Multisorb Technologies Inc.**, Buffalo, NY (US)

(57) **ABSTRACT**

The invention provides for an extended shelf life single portion package including a container having therein a material for mammal ingestion that degrades by exposure to oxygen, water vapor, or carbon dioxide, an absorber selected from at least one of a carbon dioxide absorber, water vapor absorber, and oxygen scavenger wherein the container is substantially impervious to oxygen, carbon dioxide, and water vapor.

(21) Appl. No.: **13/028,740**

(22) Filed: **Feb. 16, 2011**

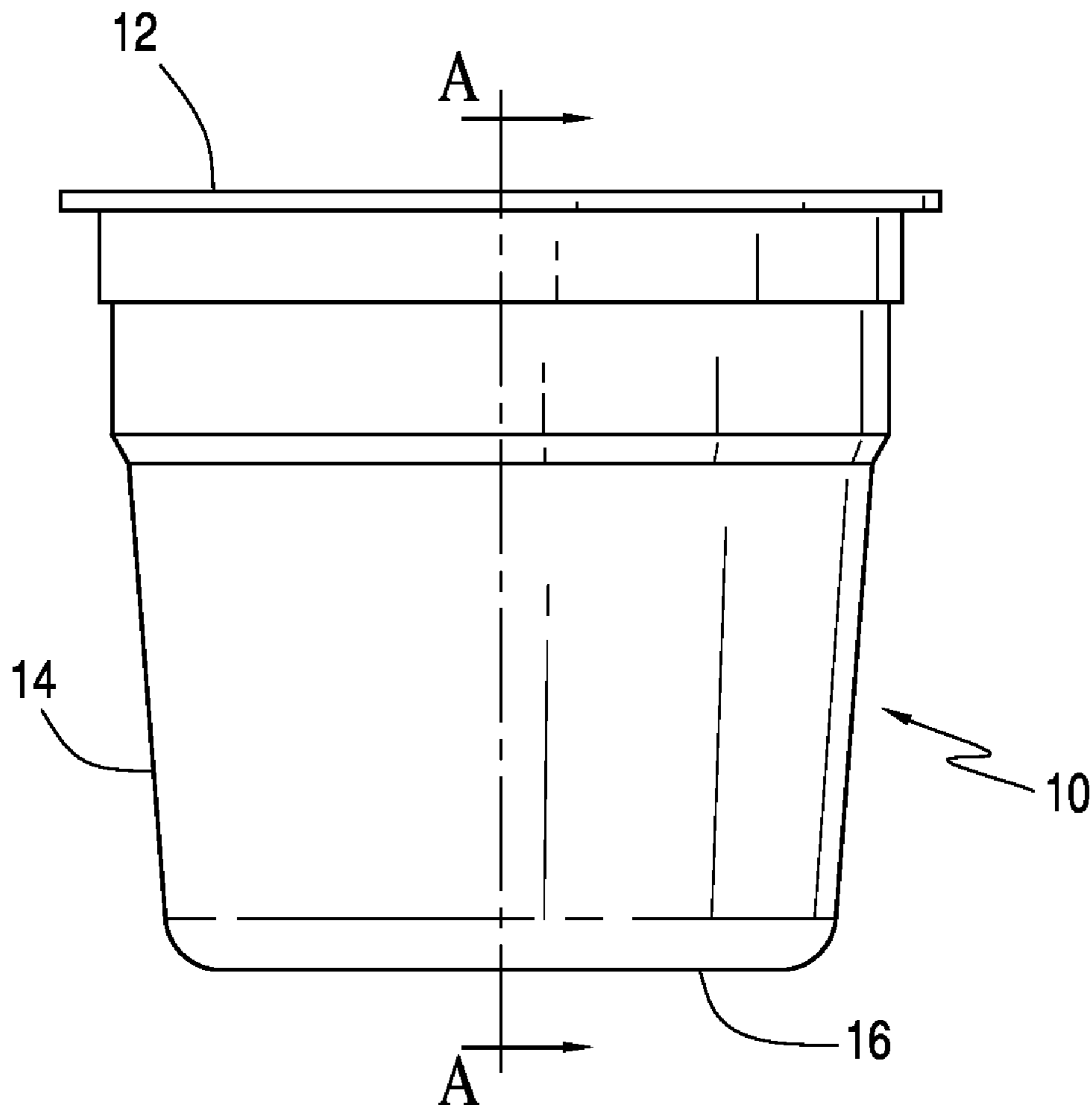

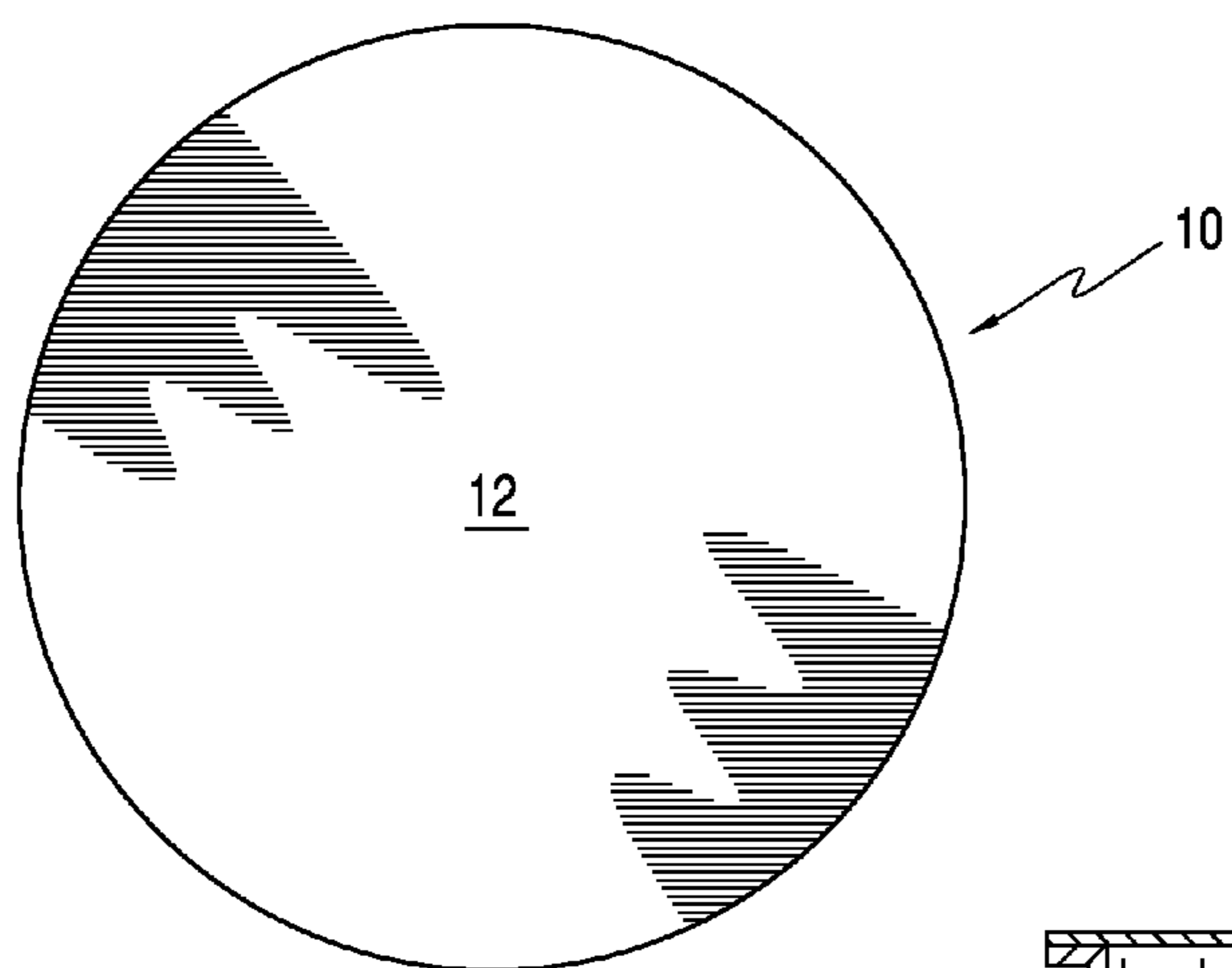

FIG. 1

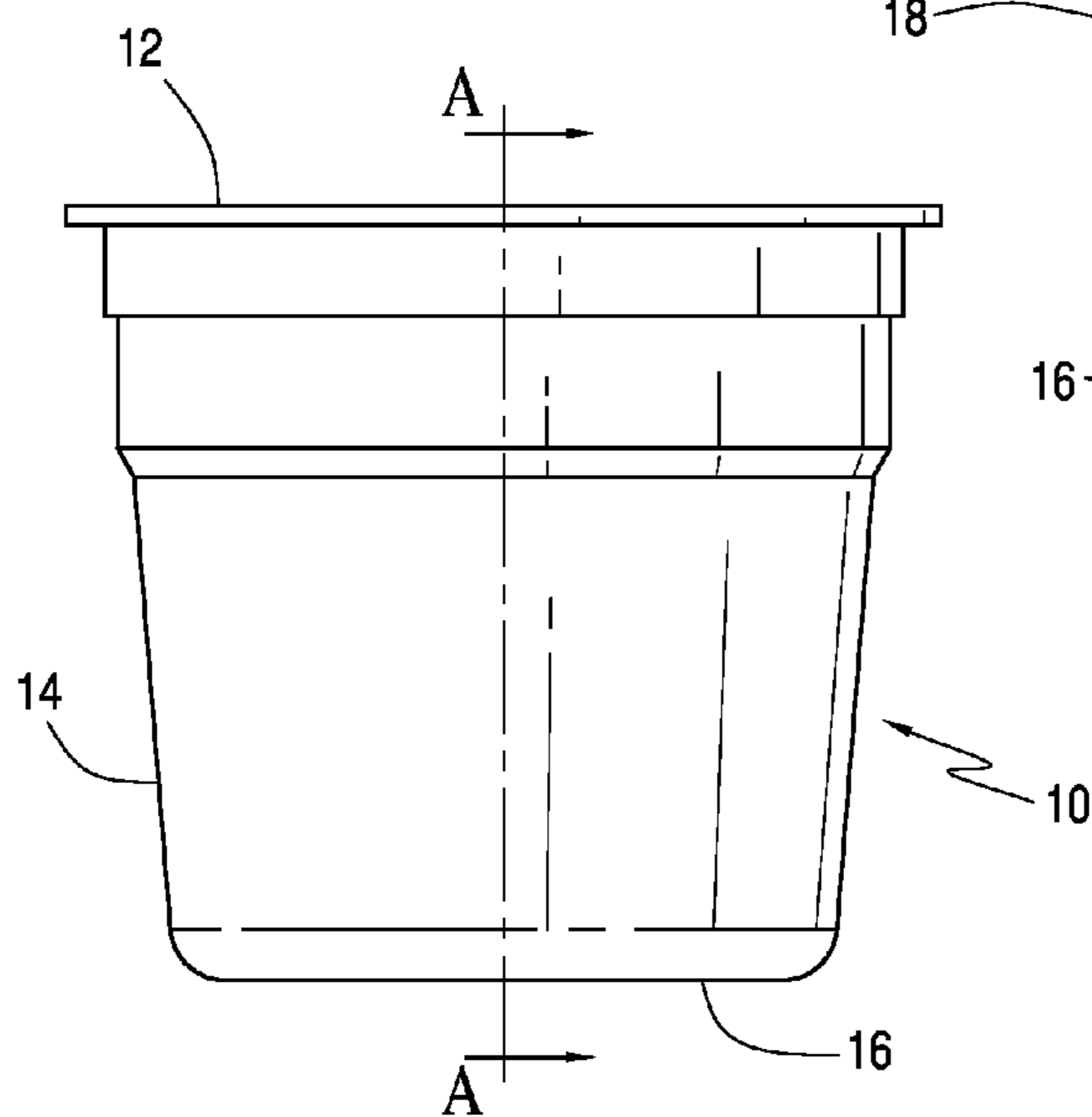

FIG. 2

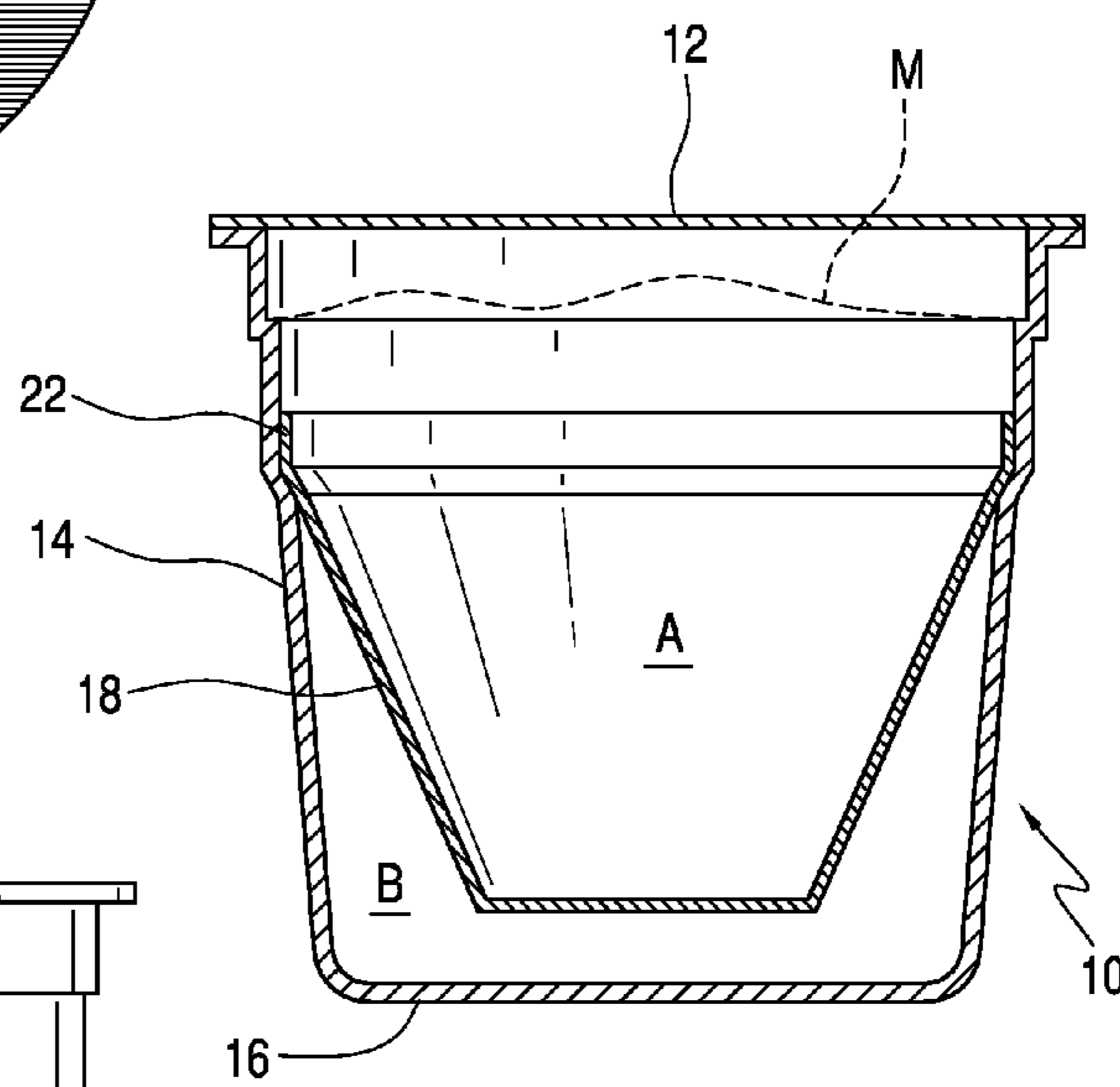

FIG. 3  
PRIOR ART

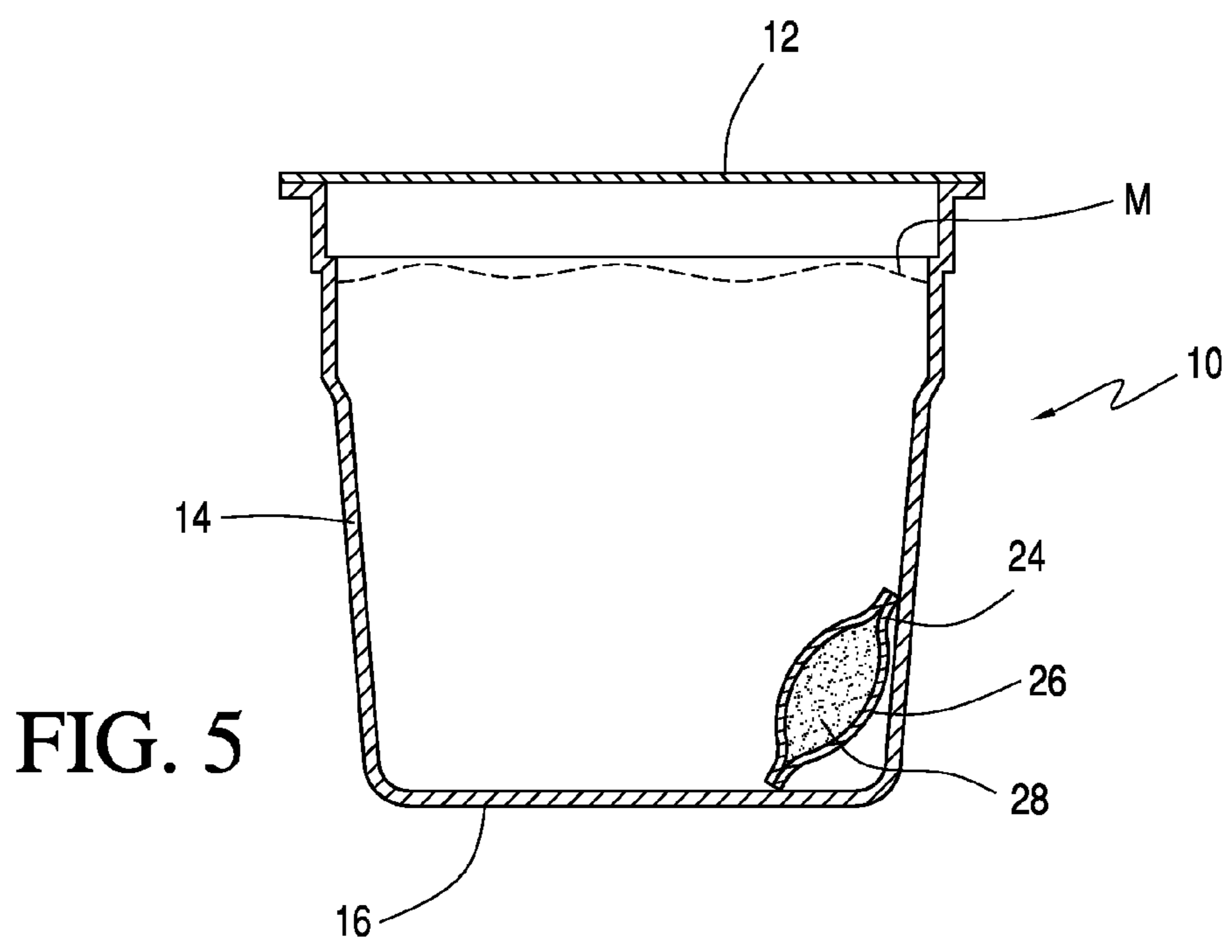
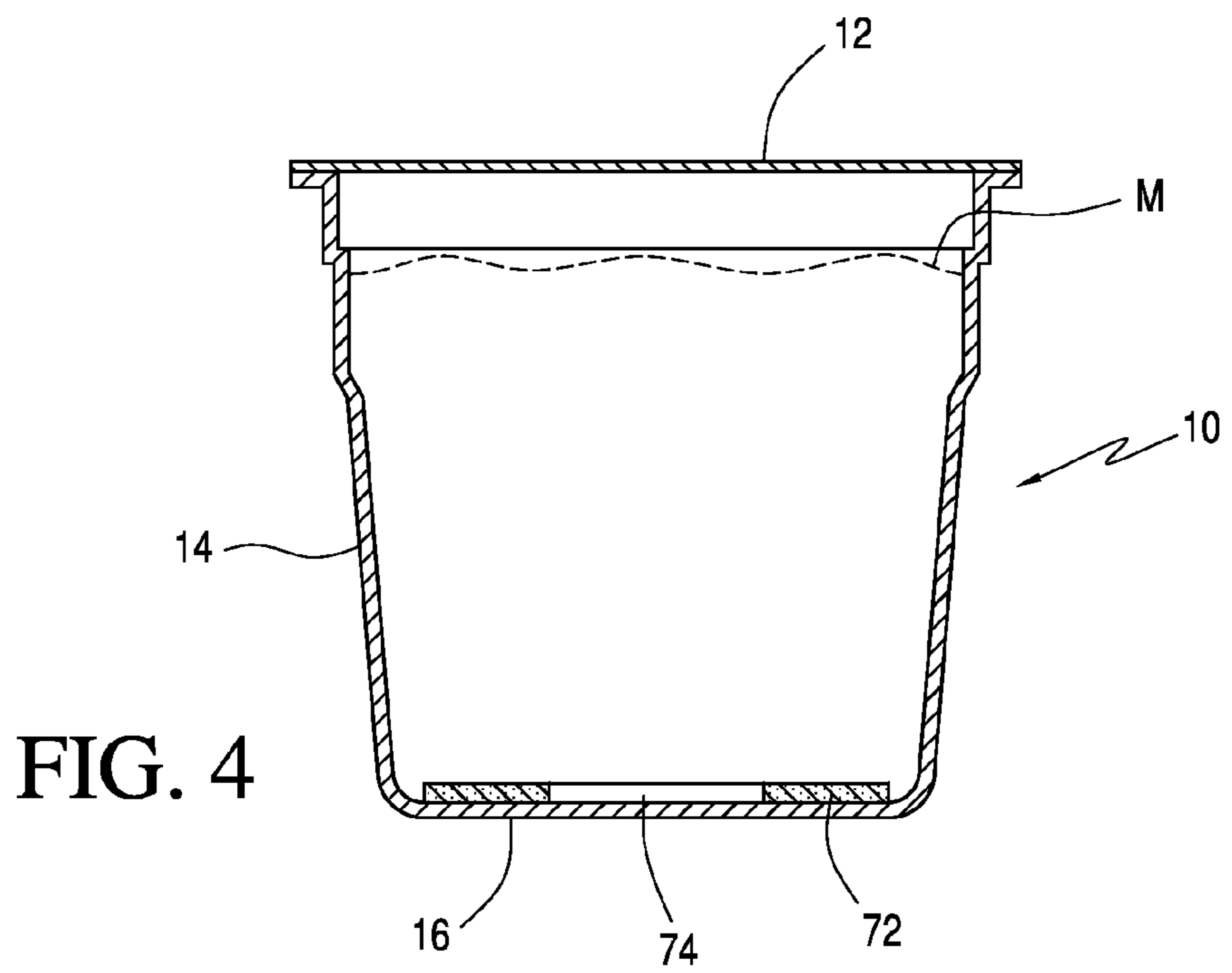

FIG. 6

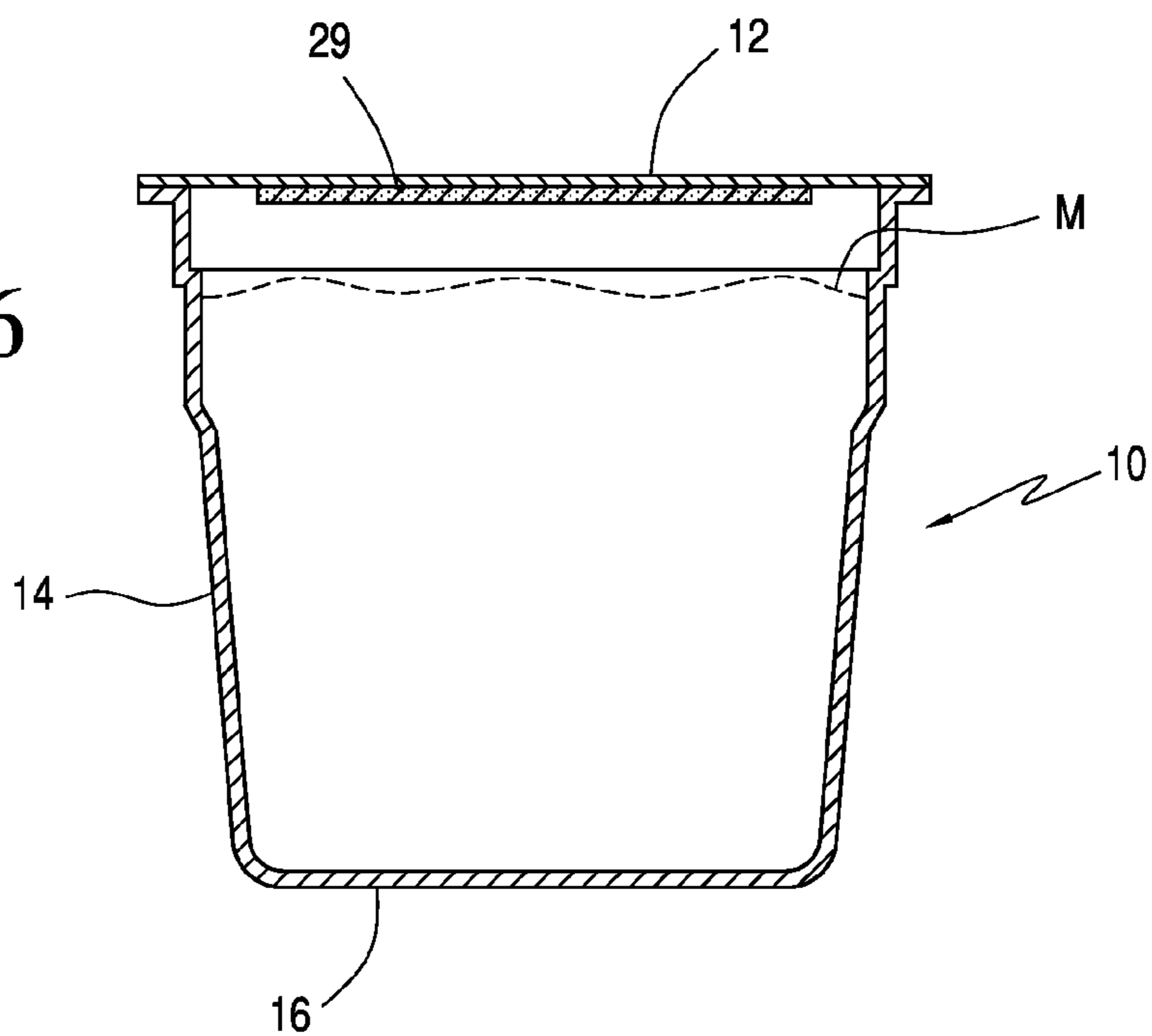
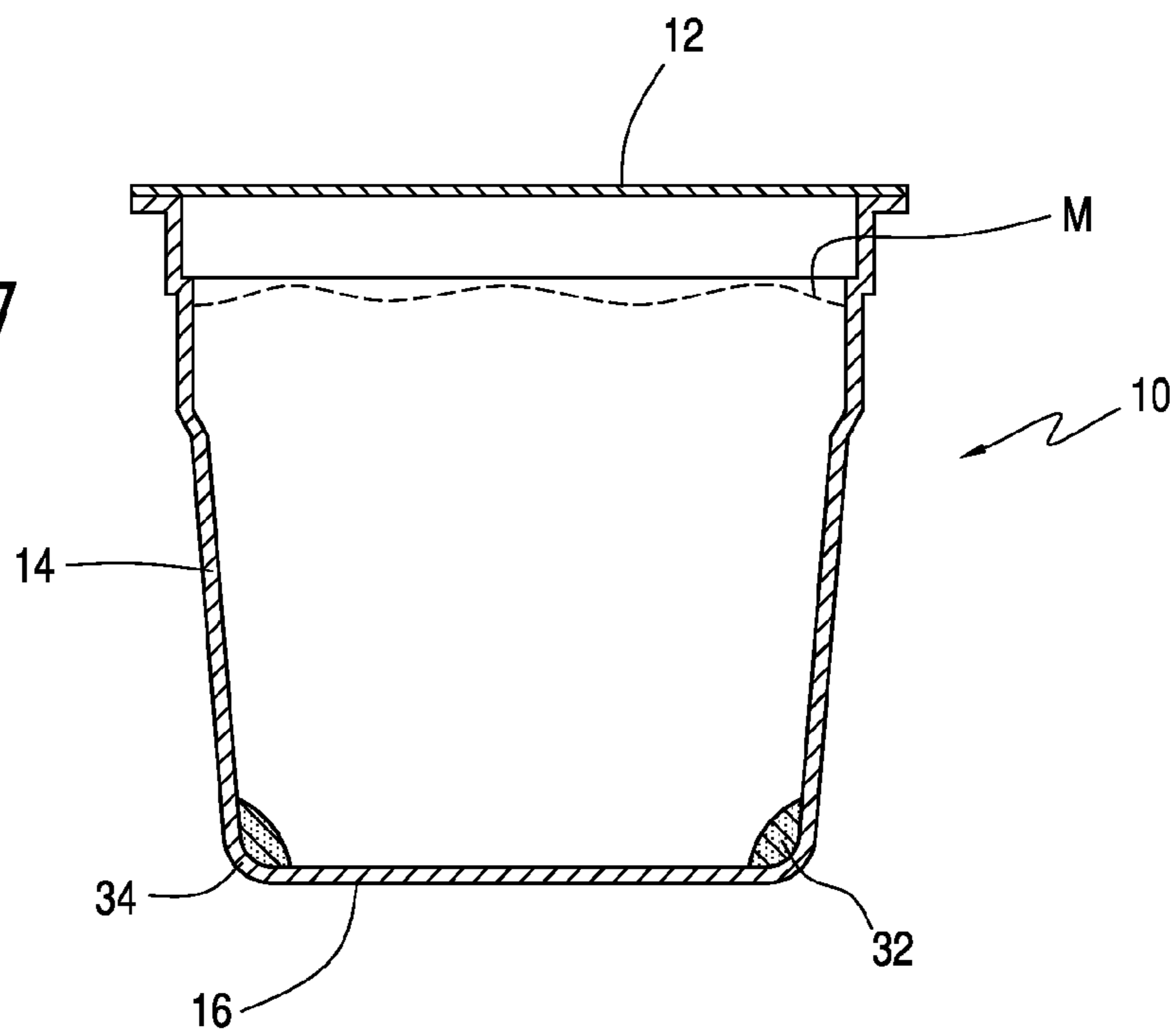

FIG. 7



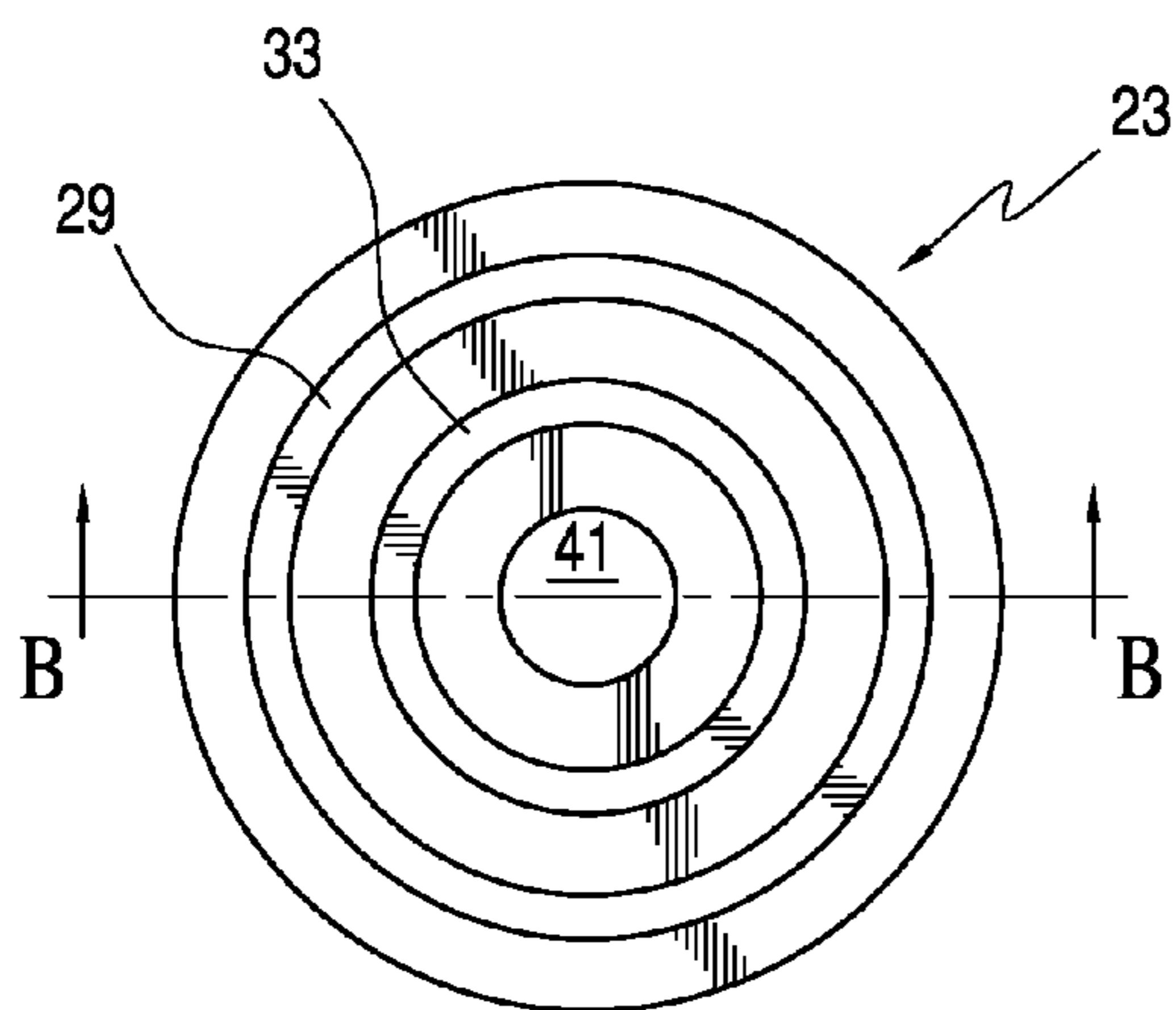

FIG. 8

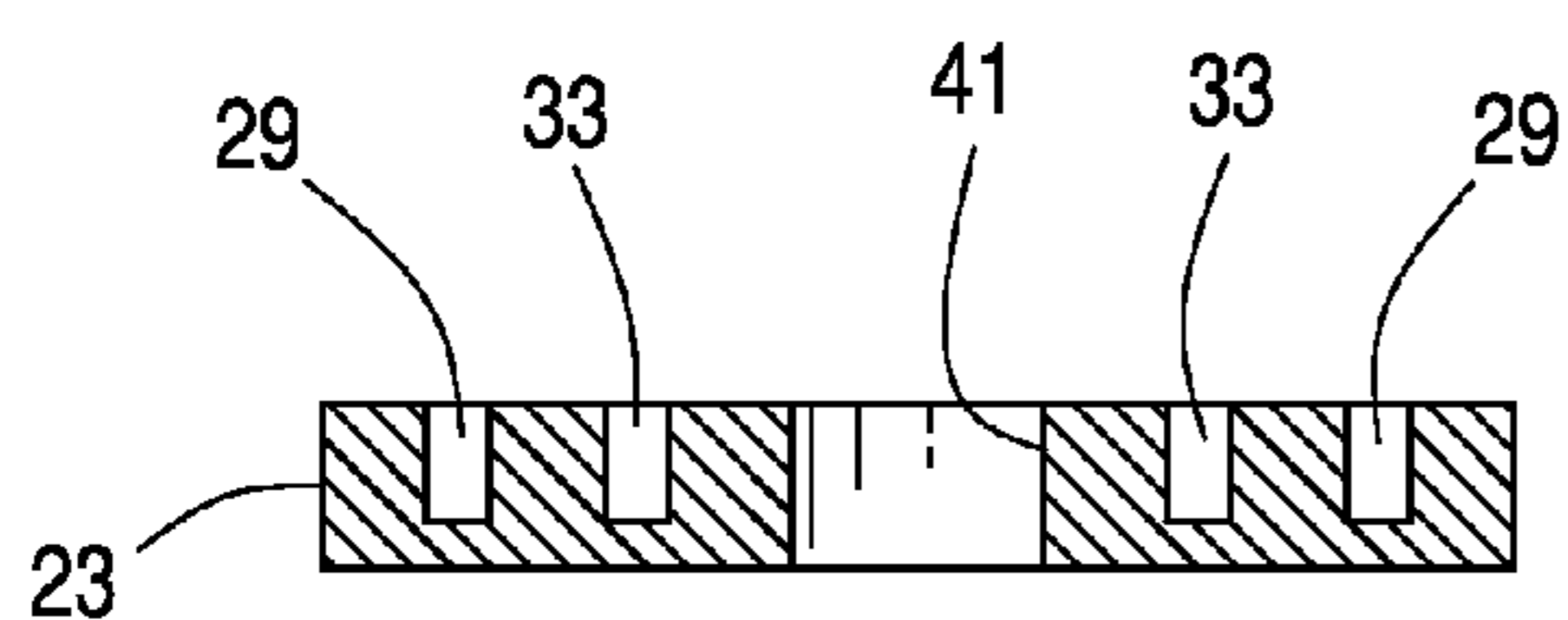

FIG. 9

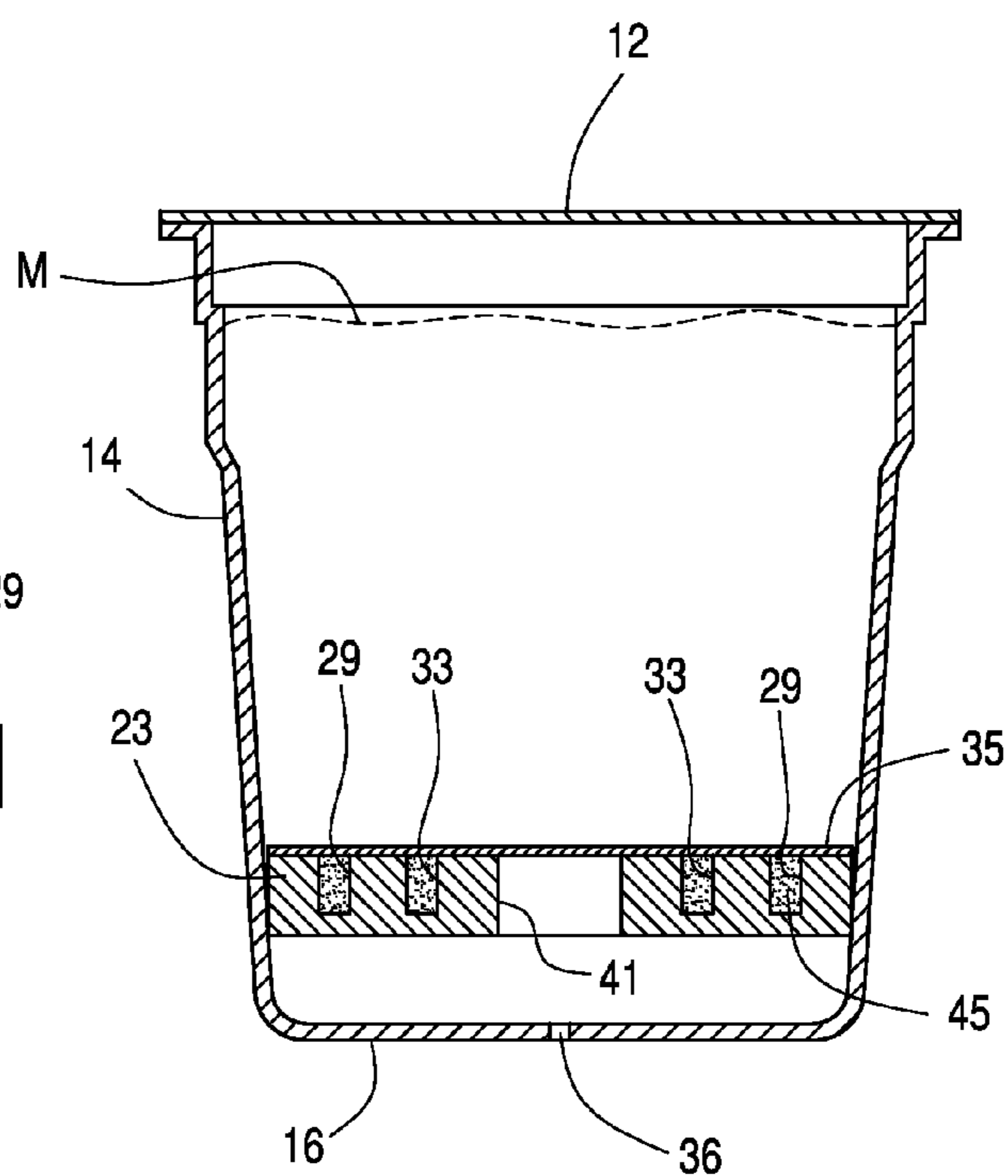

FIG. 11

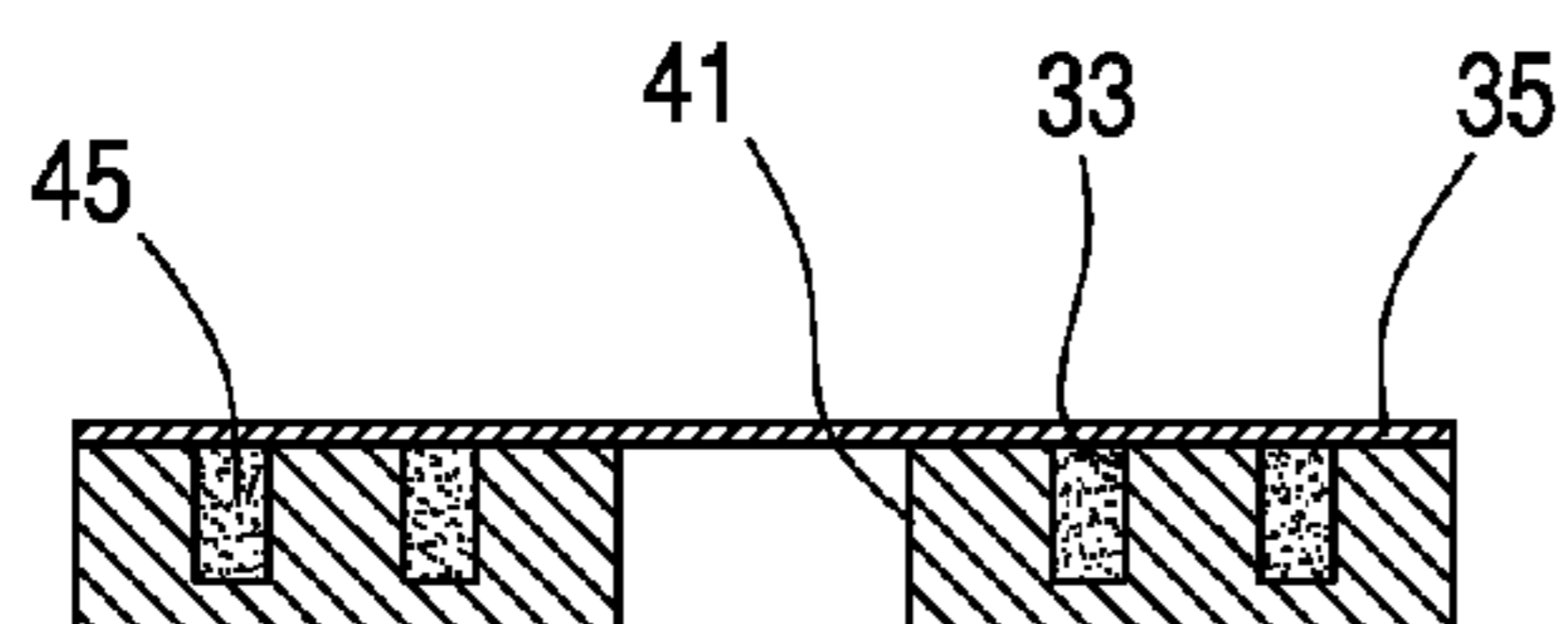

FIG. 10

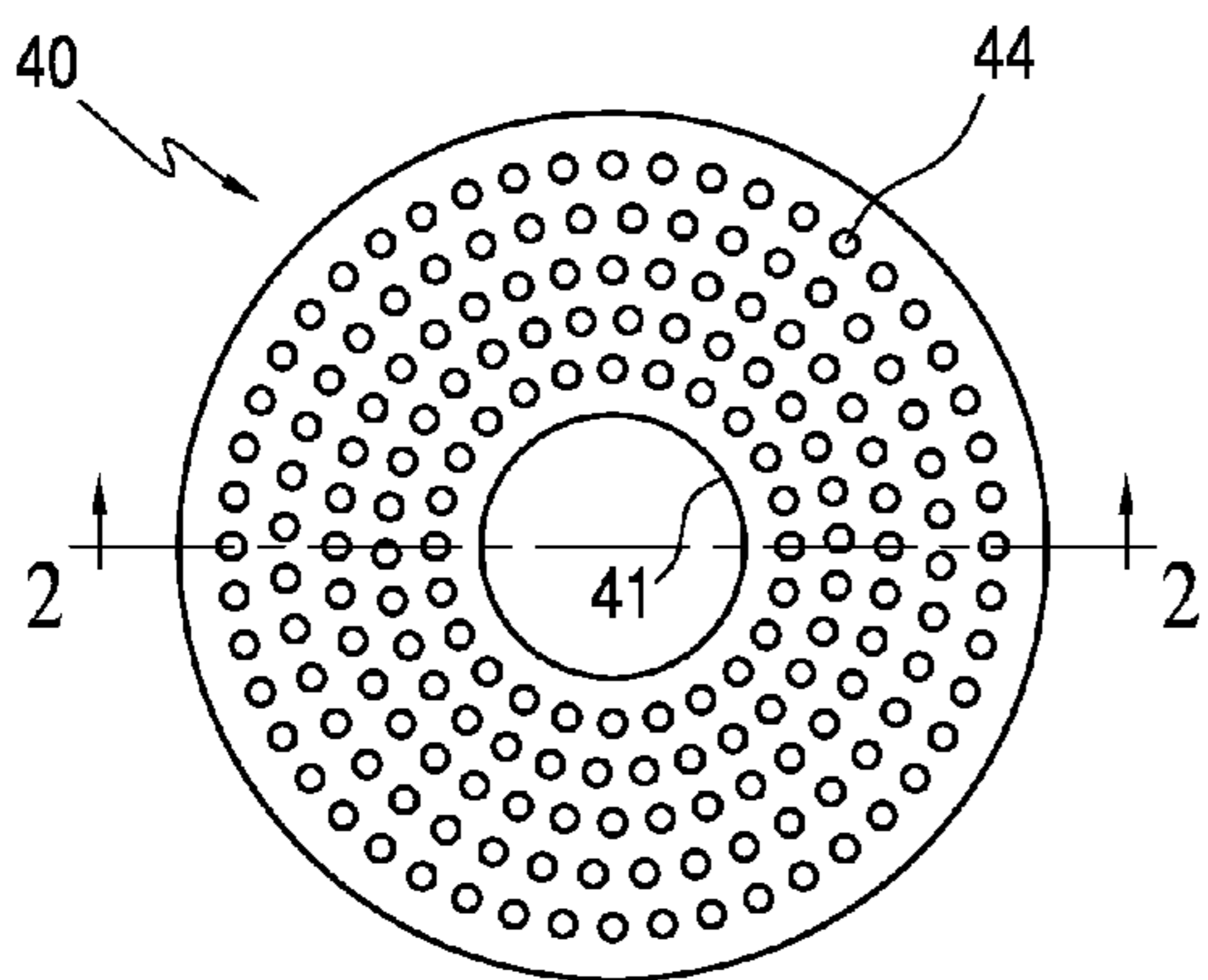

FIG. 12

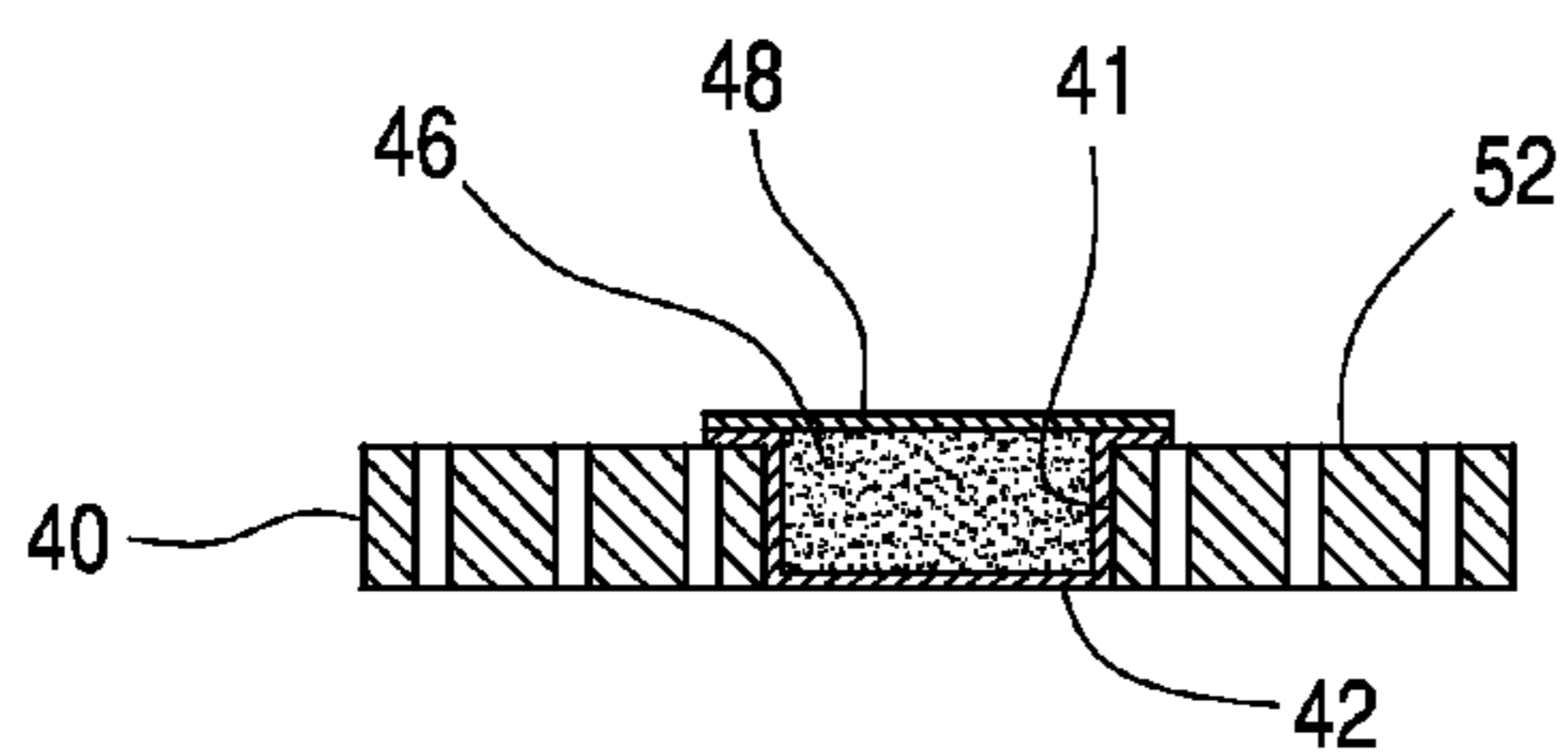

FIG. 13

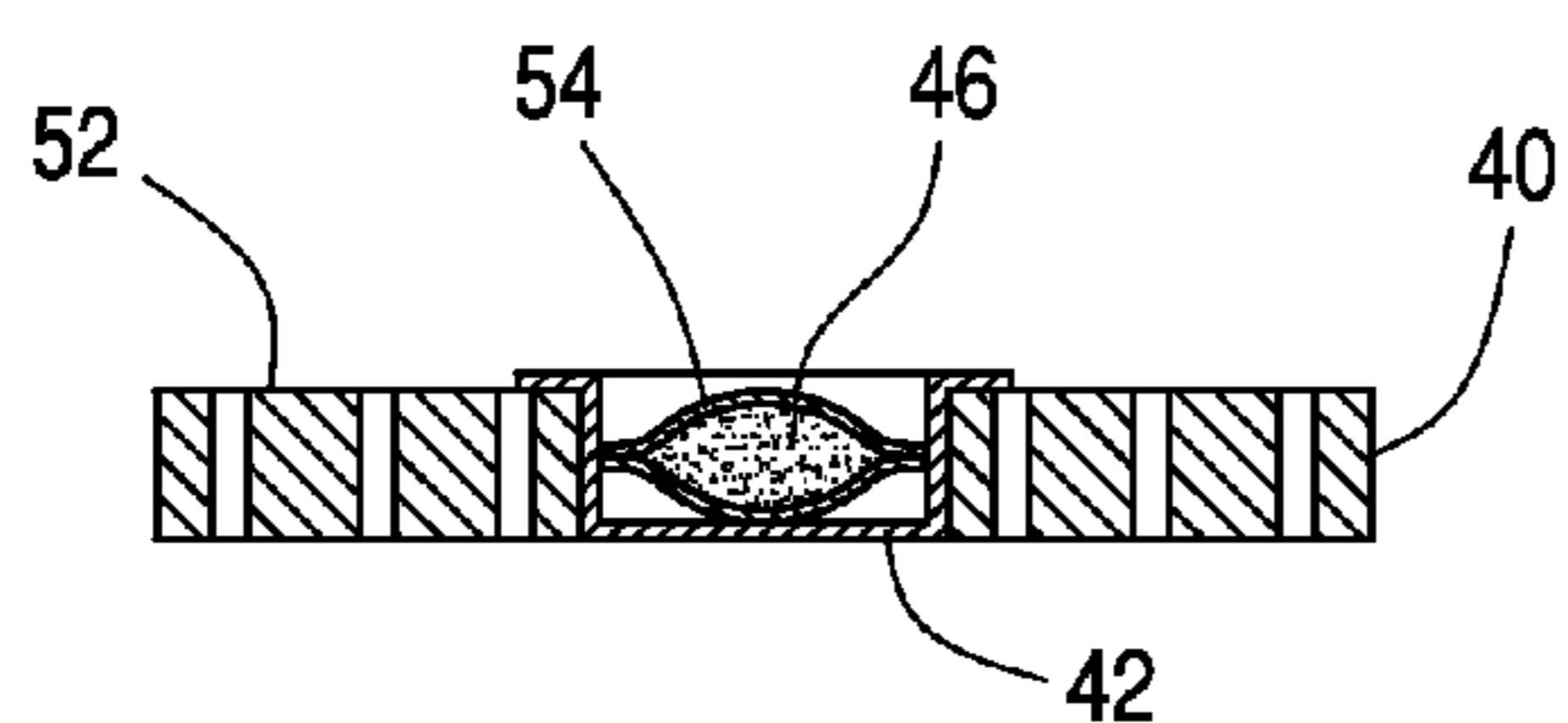

FIG. 14

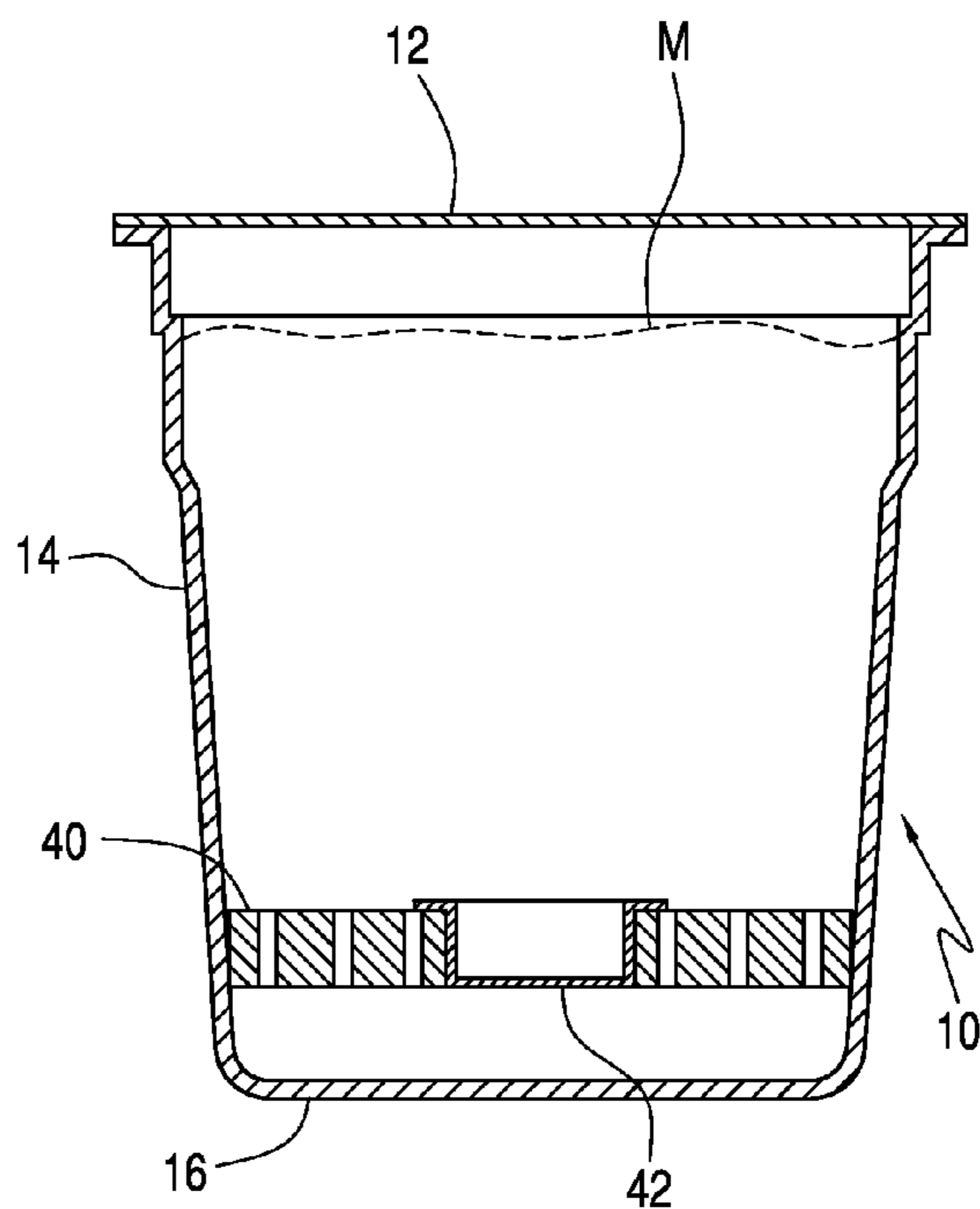

FIG. 15

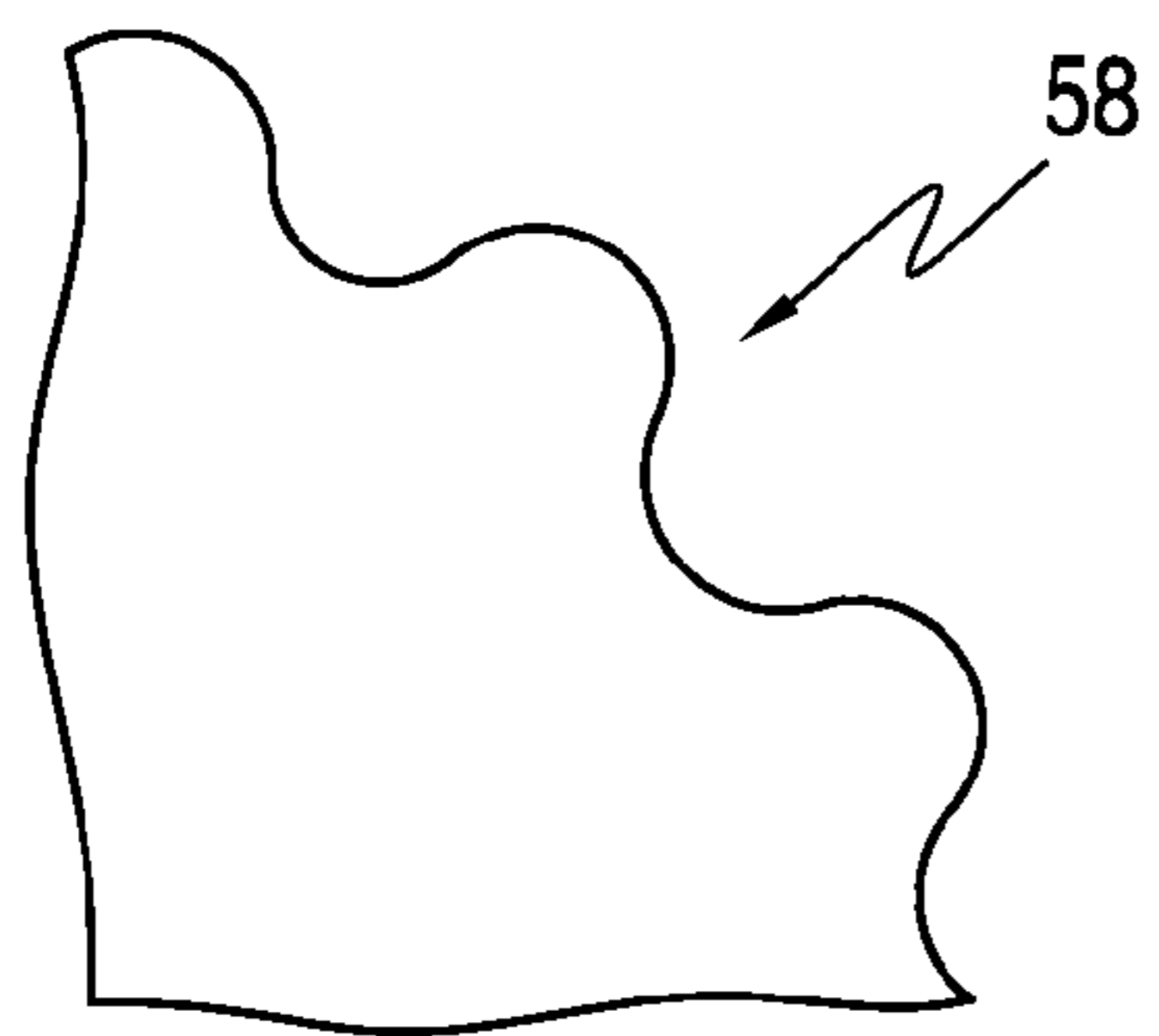

FIG. 16

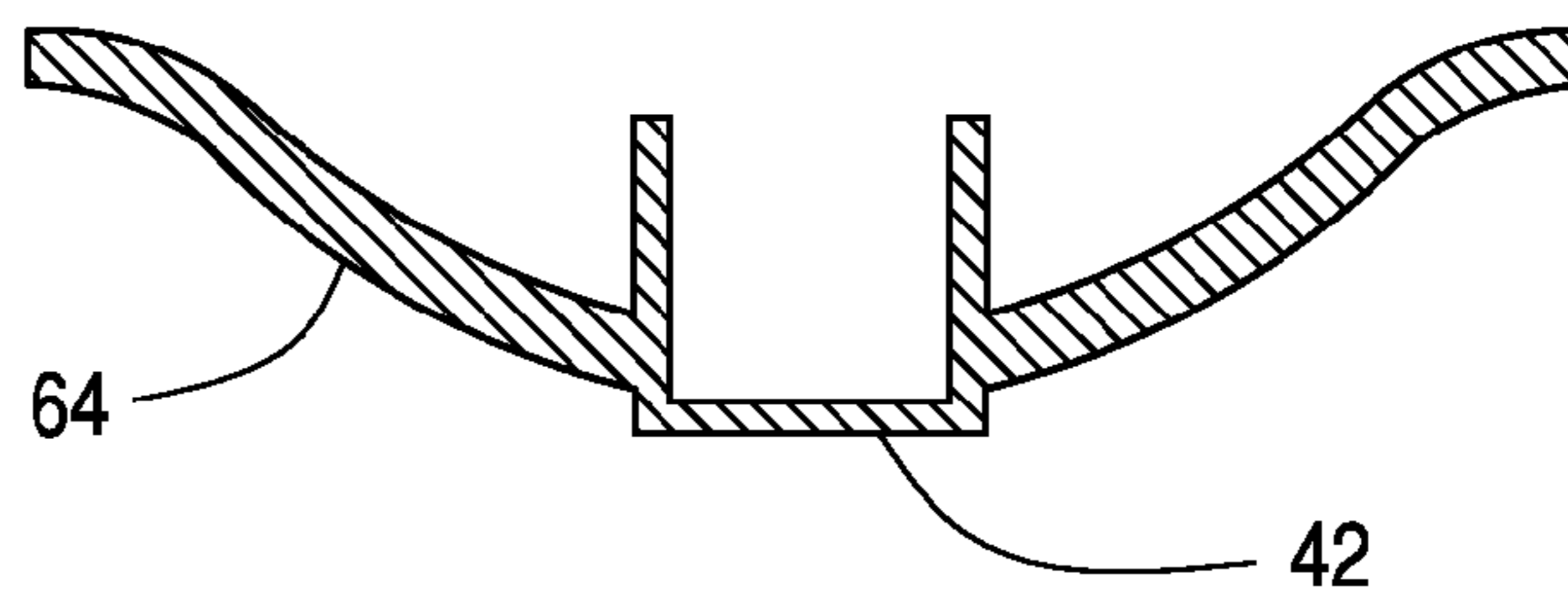

FIG. 18

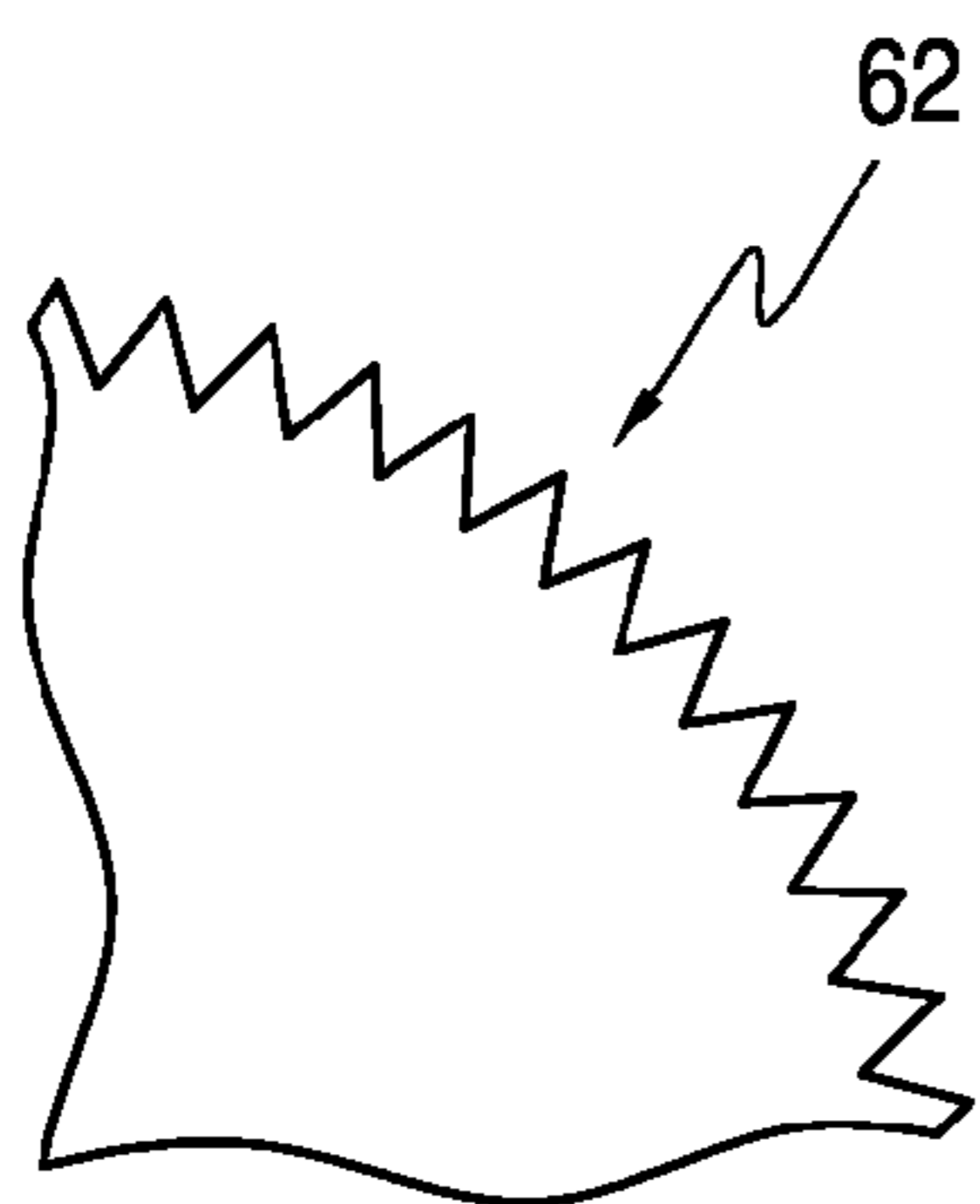

FIG. 17

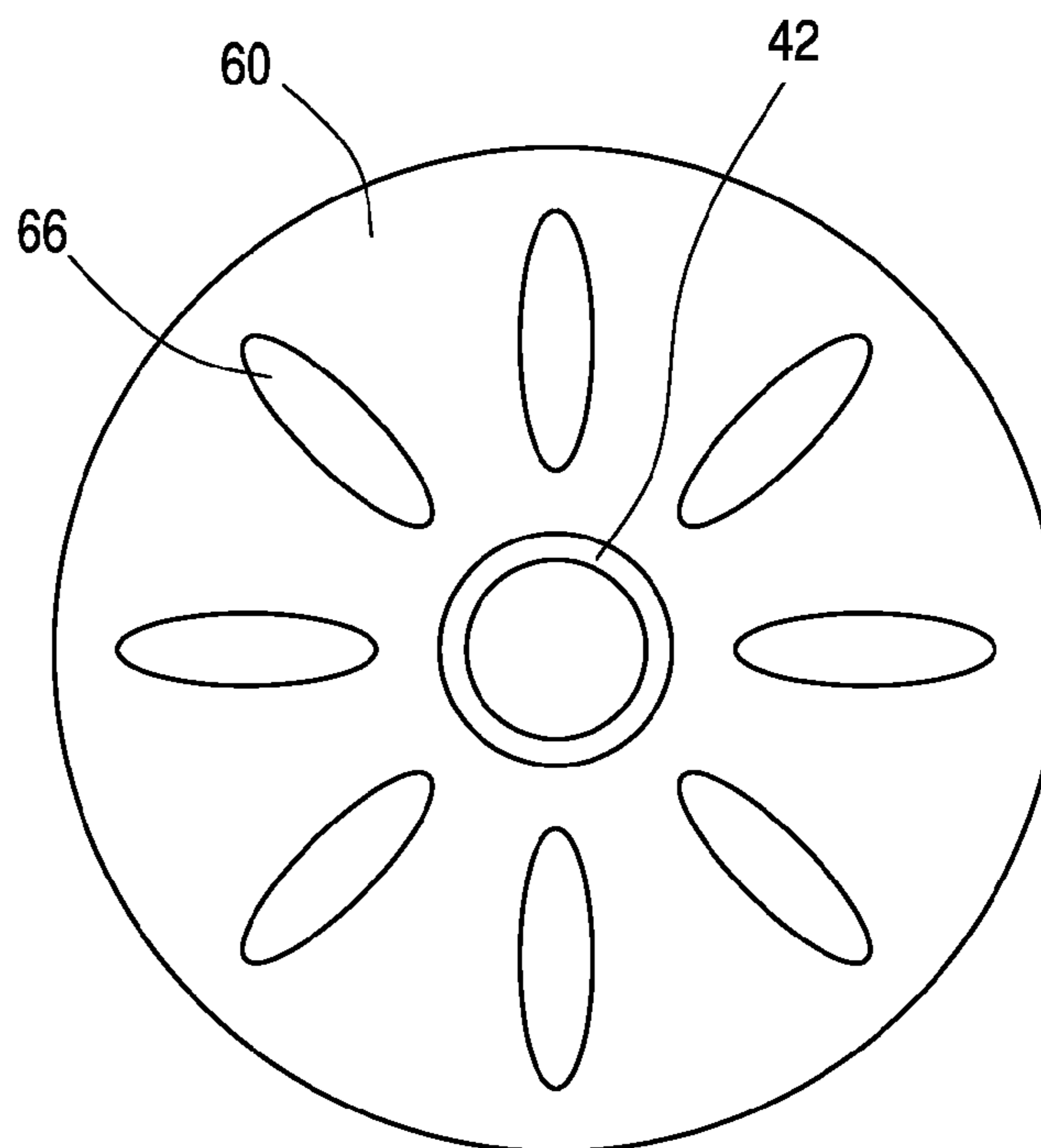

FIG. 19

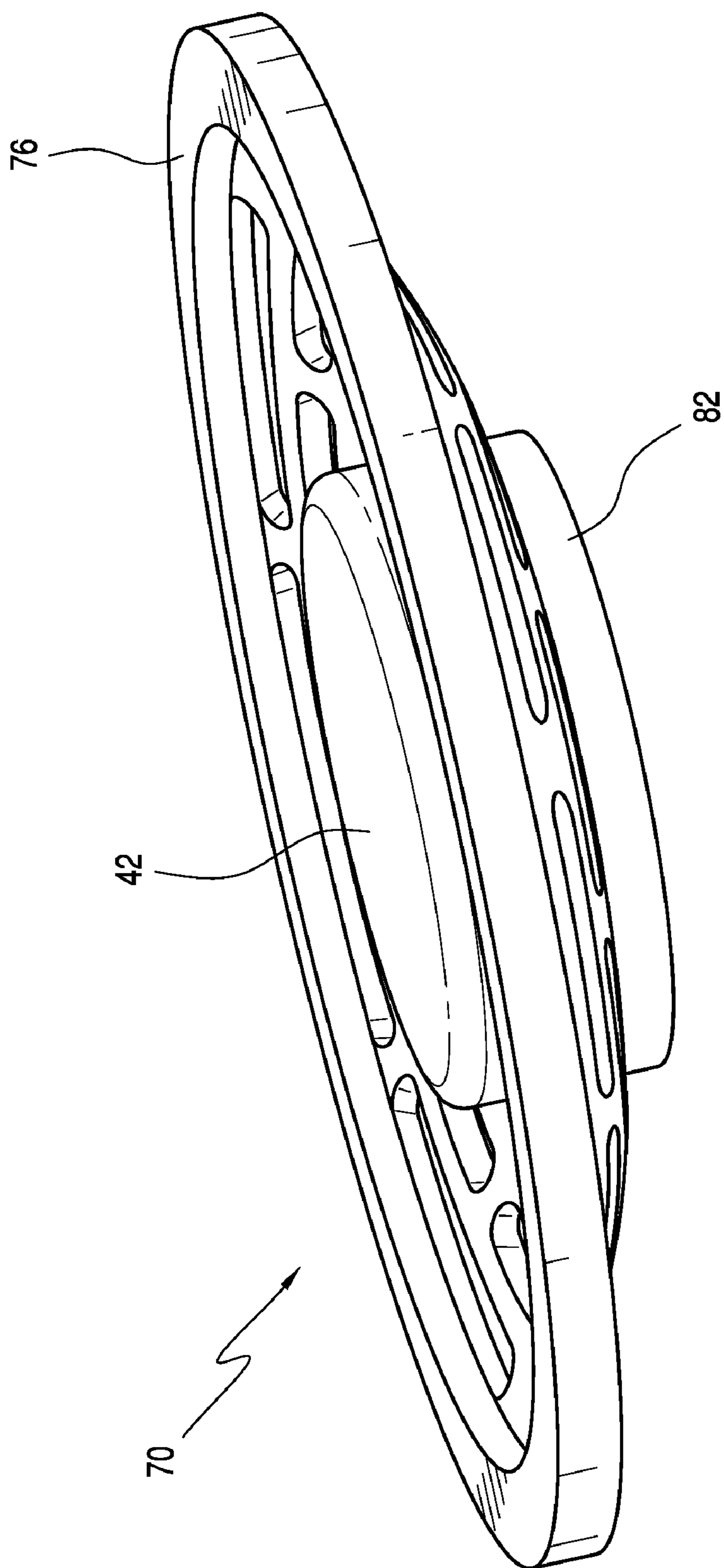

FIG. 20



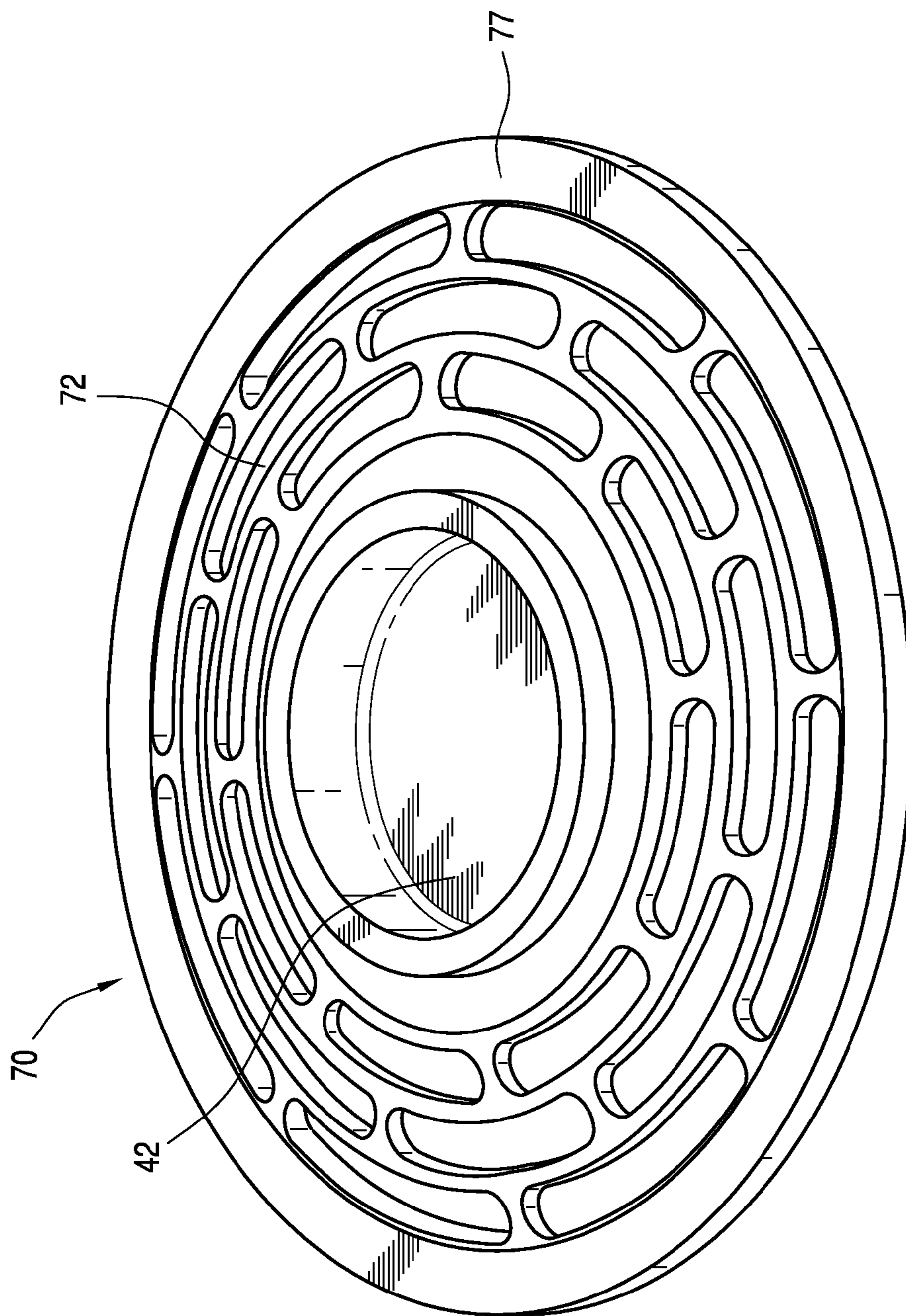

FIG. 21

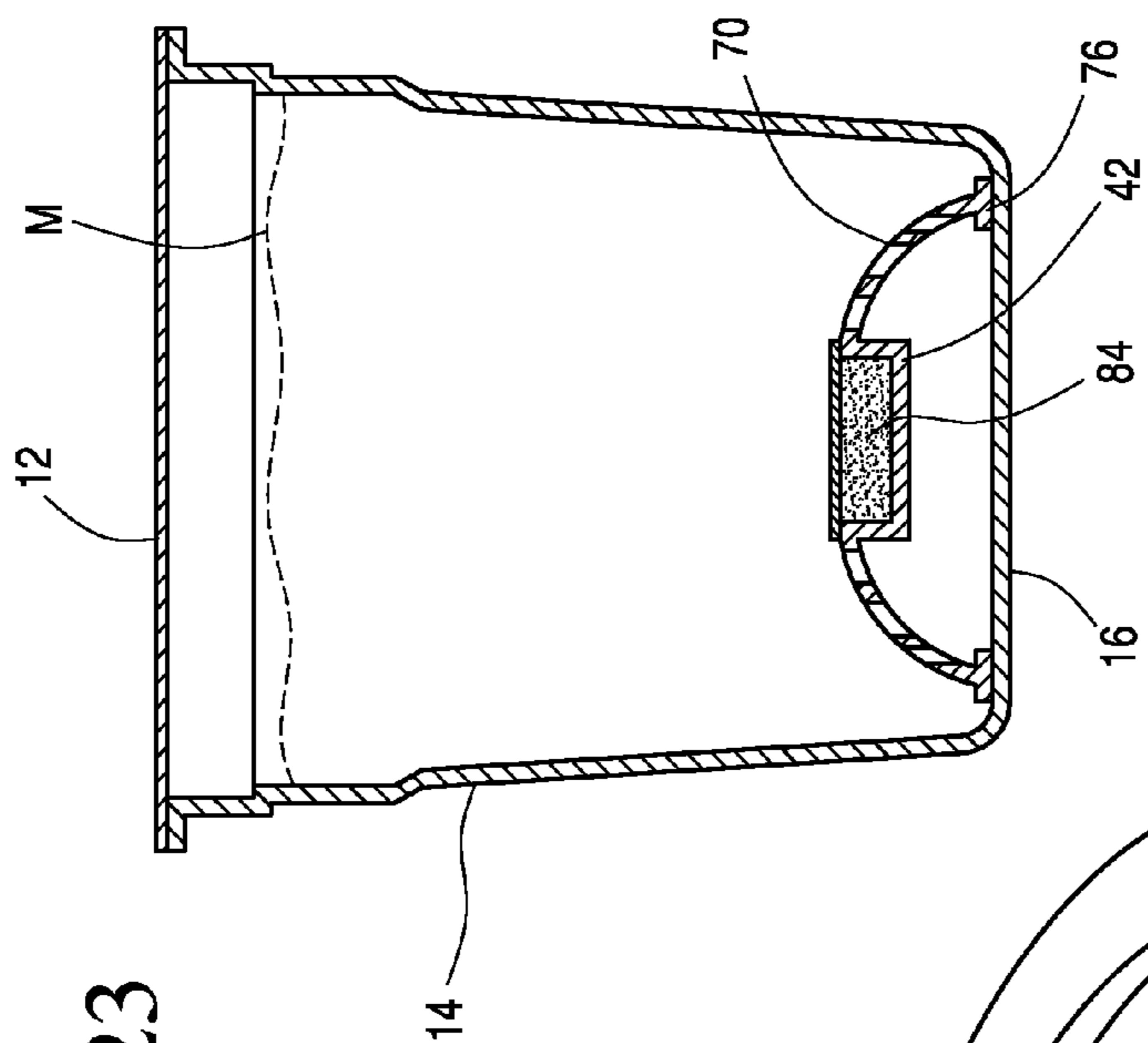

FIG. 23

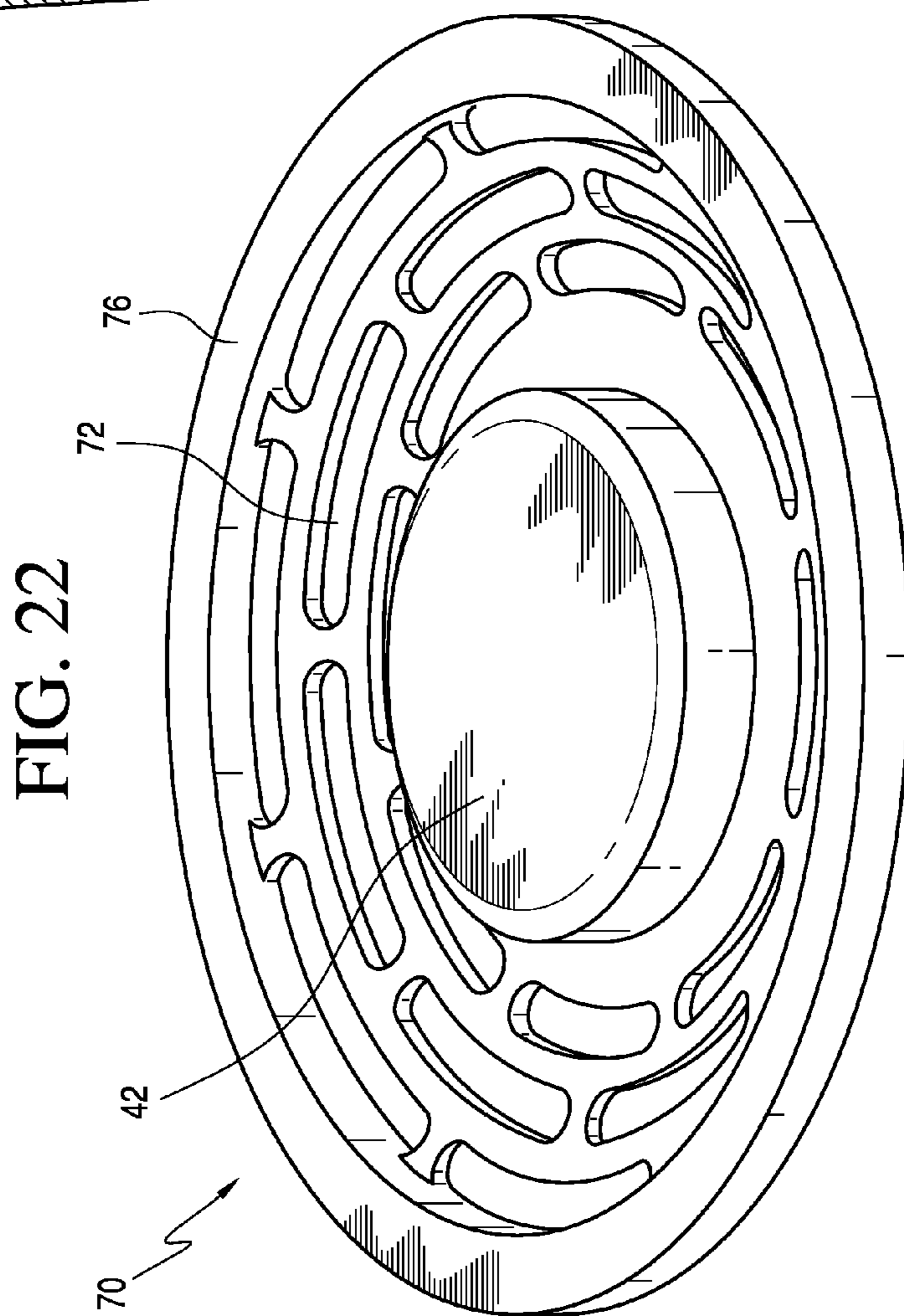
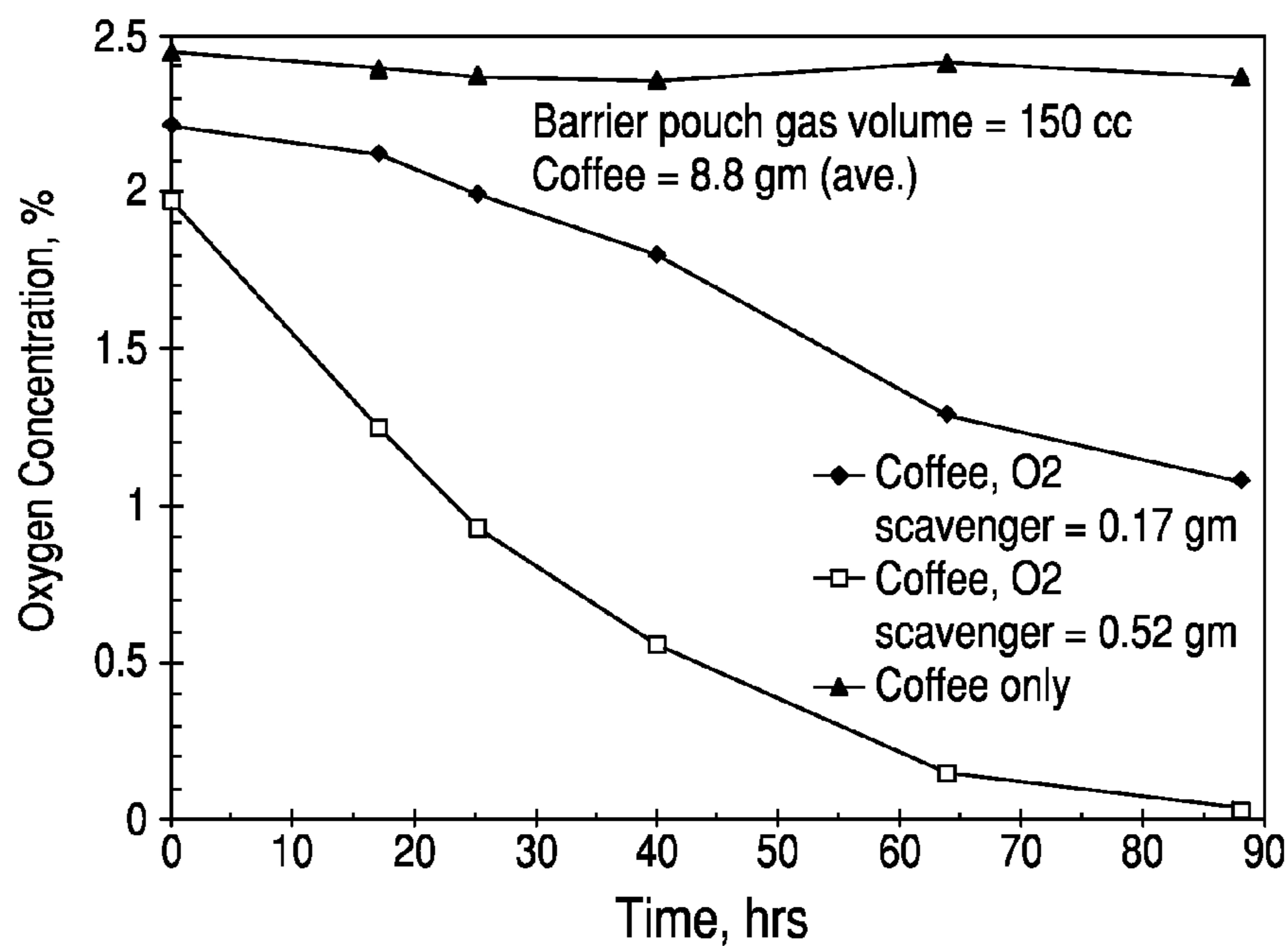
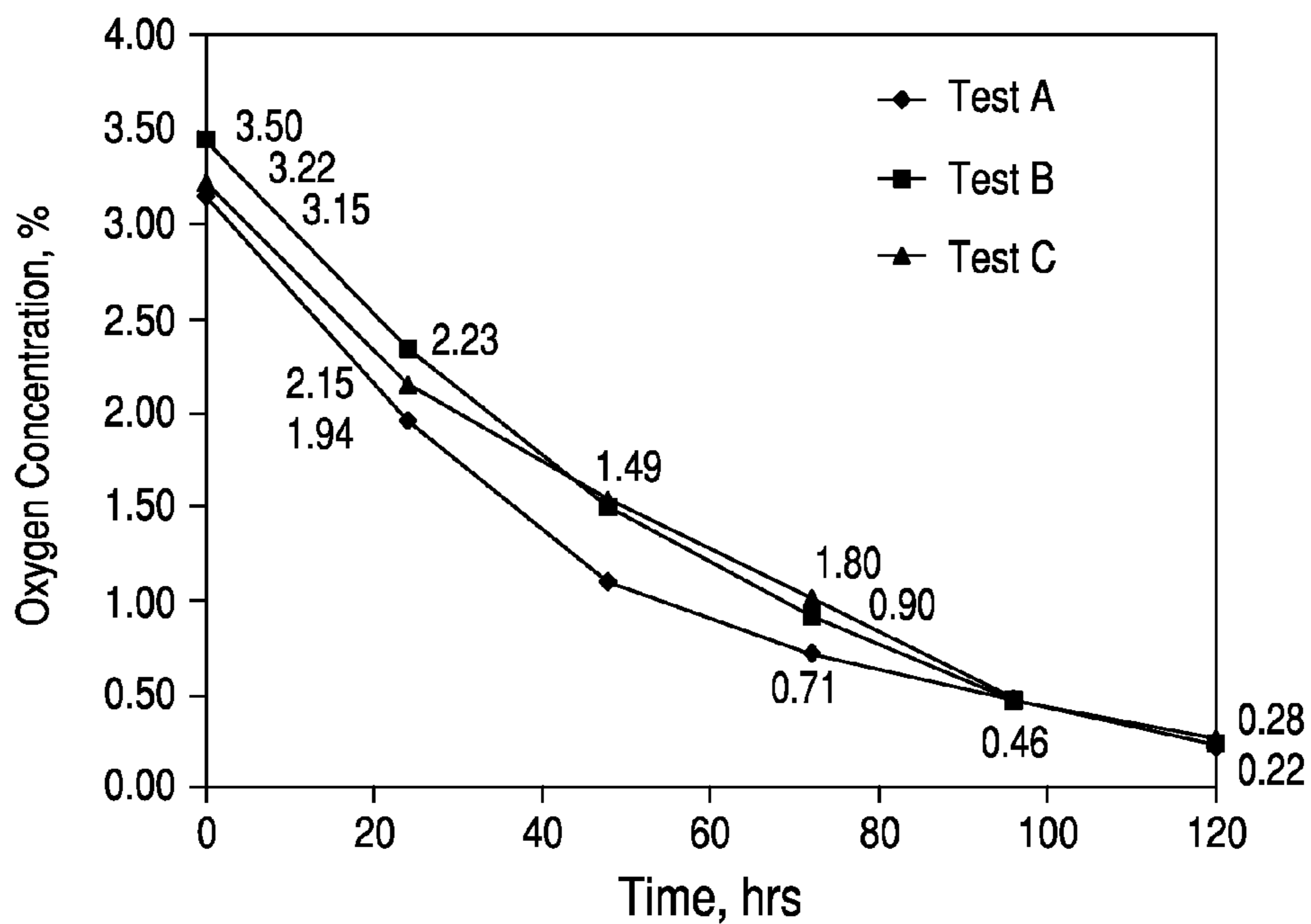

FIG. 22



**FIG. 24** Oxygen scavenging behavior of iron-based oxygen films in the presence of coffee



**FIG. 25** Oxygen scavenging behavior of iron-based oxygen scanning packet in the presence of coffee

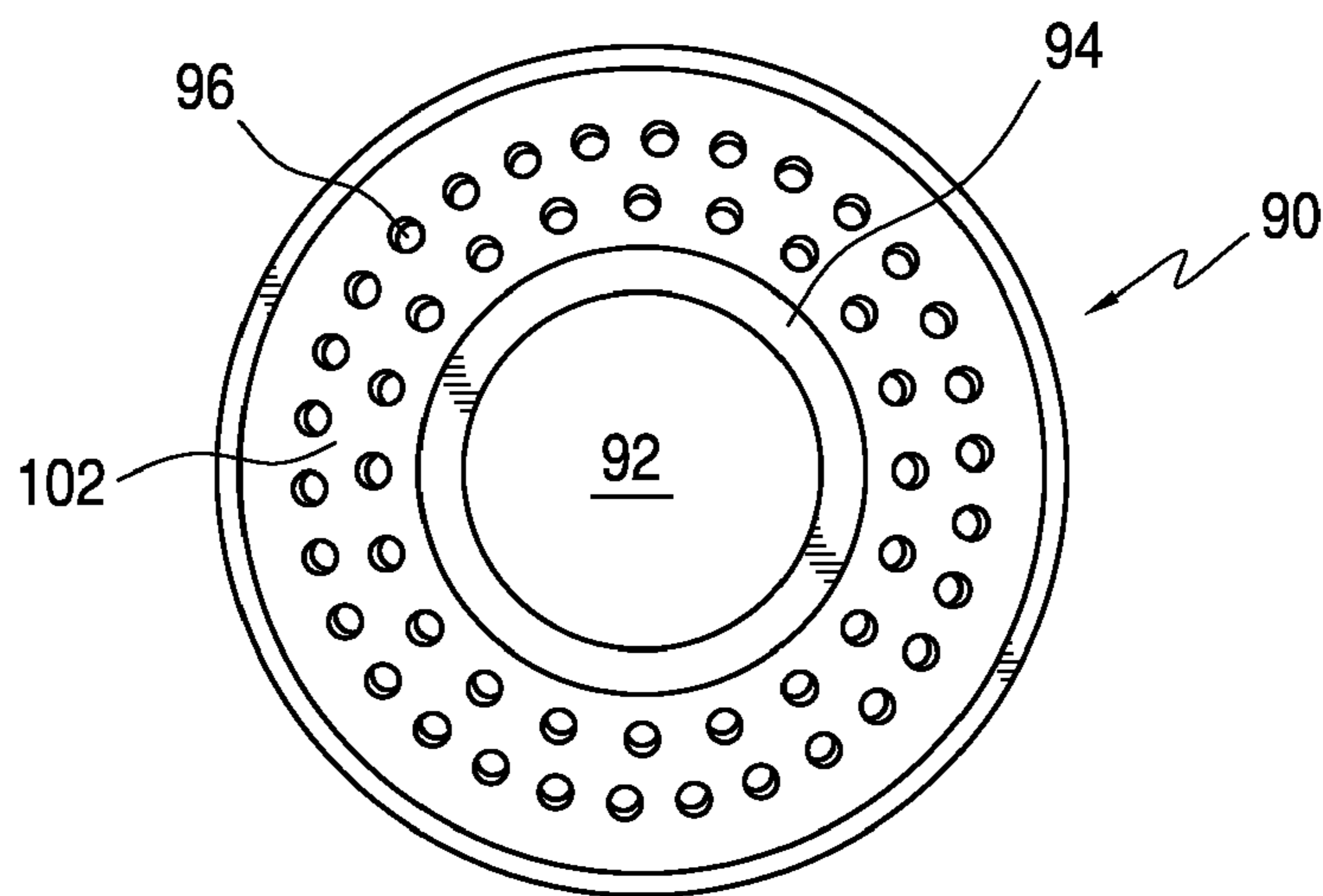

FIG. 26

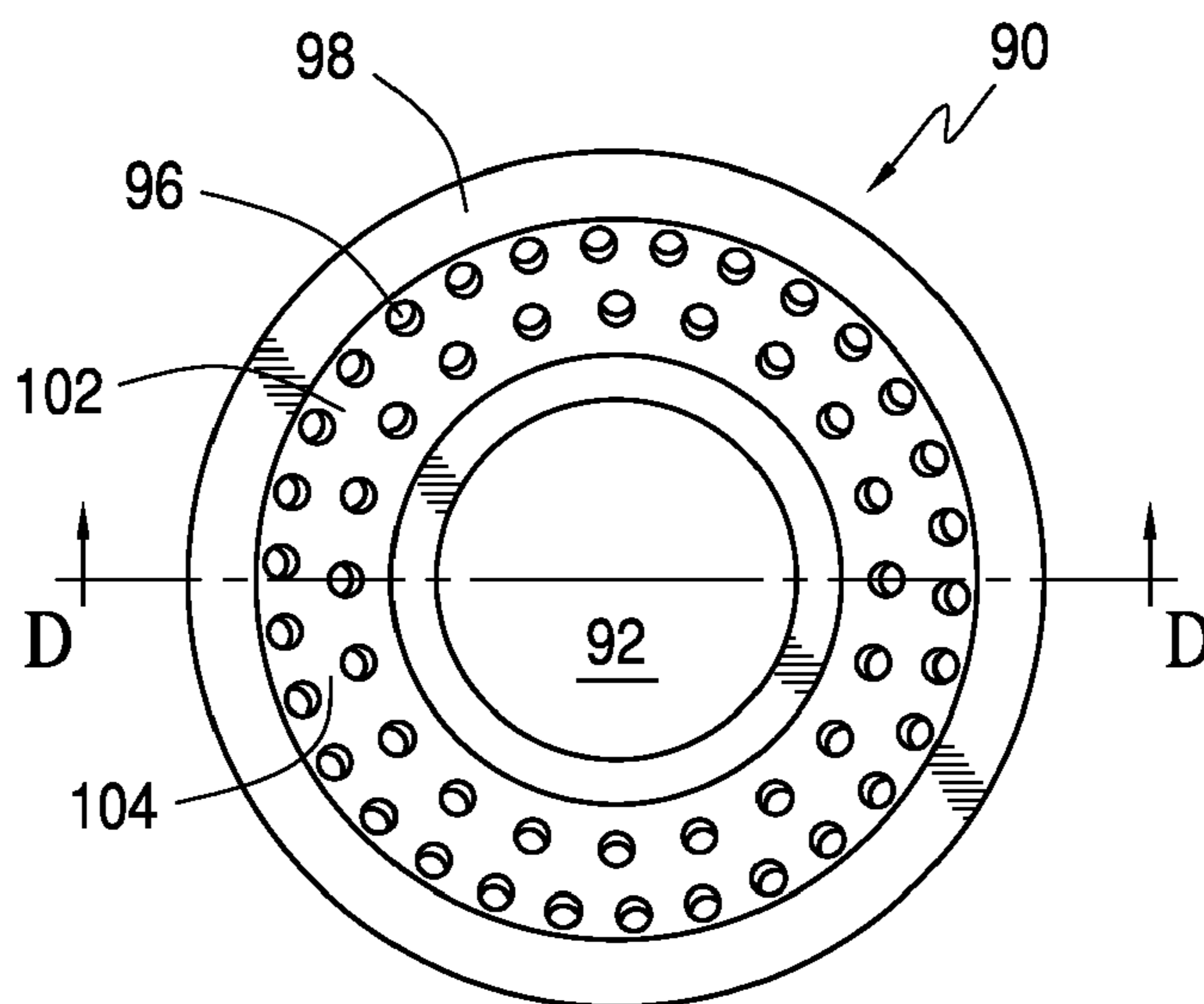

FIG. 27

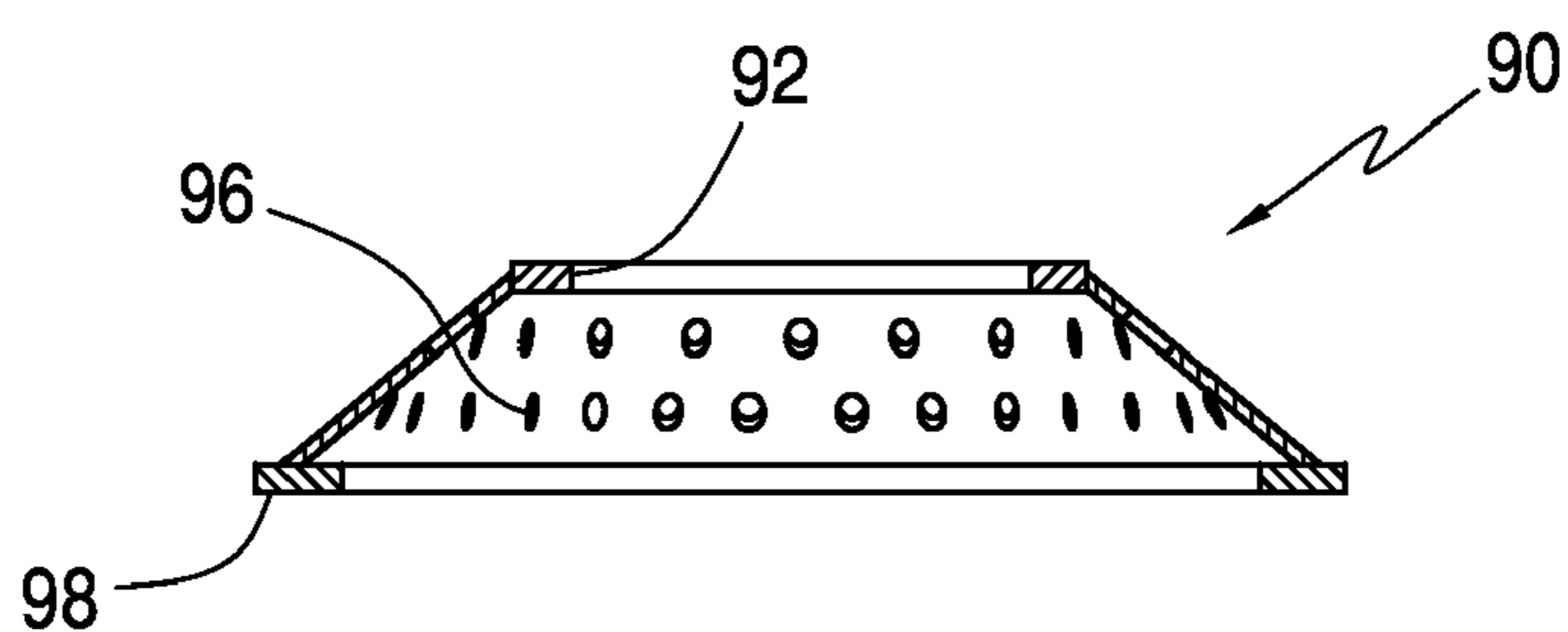

FIG. 28

**OXYGEN, WATER VAPOR, AND CARBON  
DIOXIDE ABSORPTION IN A SINGLE USE  
CONTAINER**

CROSS-REFERENCE TO RELATED  
APPLICATIONS

**[0001]** The present application is a continuation-in-part of U.S. patent application Ser. No. 12/984,230 filed Jan. 4, 2011, which is a continuation-in-part of U.S. patent application Ser. No. 12/751,583 filed Mar. 31, 2010, each of which is expressly incorporated by reference.

STATEMENT REGARDING FEDERALLY  
SPONSORED RESEARCH OR DEVELOPMENT

**[0002]** None.

REFERENCE TO A "SEQUENCE LISTING"

**[0003]** Not applicable.

BACKGROUND OF THE INVENTION

**[0004]** 1. Field of the Invention

**[0005]** The invention primarily relates to the absorption of oxygen and/or carbon dioxide as well as regulation of relative humidity/water activity control in a food product in a storage container or package. In particular, it relates to the absorption of water vapor during storage of single use food containers. The invention also relates to absorbers for carbon dioxide or a combination of oxygen and carbon dioxide scavenging.

**[0006]** 2. Description of Related Art

**[0007]** In the packaging of foods, it is known that some food deteriorates by reacting with oxygen during the time it is stored. This has been treated by evacuation of packages to reduce and/or remove oxygen before sealing, providing wax coatings on food, and by lowering the temperature of storage. It is also known to utilize oxygen scavengers in the packaging of vegetable and animal based food material. There has been a particular interest in the preventing of oxidation of ground coffee as oxidation decreases the aroma and taste of the product. Coffee has been vacuum-packed or packed in nitrogen to remove as much oxygen as possible.

**[0008]** Certain foods also may emit CO<sub>2</sub> or other volatiles either through respiration or baking or roasting. Coffee in particular and roasted nuts produce a significant amount of carbon dioxide when roasted. Coffee producers must then let coffee off-gas carbon dioxide prior to packaging or include a vent so that the package will not swell and/or burst. The time that is necessary to off-gas carbon dioxide also potentially allows volatile flavor compounds to escape. Employing a carbon dioxide scavenger will allow coffee to be packaged soon after roasting without accumulation of carbon dioxide gas. This lack of staging/exposure for off-gassing will not only eliminate this economically negative processing time but will also consequently result in retaining co-offgassing compounds/volatiles that by their nature impart desirable characteristics of the organoleptic profile of the coffee product.

**[0009]** Additionally, instant coffee and instant tea are quite aromatic and pleasantly so. Because these desirable flavor aromatics are volatile, any time lost between formation and packaging diminishes flavor and consumer acceptance. A method of adsorbing CO<sub>2</sub> would allow instant coffee, instant tea, and other foods to be packaged and preserve aroma and flavor.

**[0010]** In addition to ground coffee and leaf tea where residue of used coffee grounds and tea leaves are present, there are substantially soluble materials to make hot and cold drinks that present storage difficulties. Instant tea, instant juices, and instant coffee may lose flavor and aroma as well as be subject to water absorption which will cause clumping or solidification of the material. Other hot drinks such as cocoa, grain beverages, and hot cold remedy beverages also suffer from storage difficulties. It would be desirable if these materials could be stored in such a way as to prevent their caking or agglomeration. Further, it would be desirable if such materials could be stored in single use containers with protection from clumping and maintaining flavor and aroma while being ready for instant conversion to a beverage.

**[0011]** There is a need to provide oxygen removal, carbon dioxide removal system, and desiccant system which is relatively inexpensive and which is sufficiently potent to remove oxygen, carbon, and water vapor from instant and soluble beverage components.

**[0012]** In particular, there is a need for improvement in storage techniques for single use instant beverage containers. The single use containers are not always subject to good inventory control and therefore may sit on shelves for a long period of time. Further, it is not economical to package a single use containers in sophisticated, very low oxygen, water vapor, or nitrogen atmosphere. Typically, single use containers have about 3-5% oxygen by weight in the atmosphere of the container and a varying content of water vapor during packaging and shipping.

BRIEF SUMMARY OF THE INVENTION

**[0013]** The invention provides for an extended shelf life single portion package including a container having therein a material for mammal ingestion that degrades by exposure to oxygen, water vapor, or carbon dioxide, an absorber selected from at least one of a carbon dioxide absorber, water vapor absorber, and oxygen scavenger wherein the container is substantially impervious to oxygen, carbon dioxide, and water vapor.

BRIEF DESCRIPTION OF THE SEVERAL  
VIEWS OF THE DRAWINGS

**[0014]** FIG. 1 and FIG. 2 are top and side views of a container for use in the invention.

**[0015]** FIG. 3 is a cross-section on line A-A of FIG. 2 of a prior art ready-to-brew coffee container.

**[0016]** FIG. 4 is a cross-section of a single use container with a washer shape absorber.

**[0017]** FIG. 5 is an illustration of the invention utilizing a sachet containing oxygen scavenger or carbon dioxide scavenger, humidity regulator or a combination of scavengers and humidity regulators.

**[0018]** FIG. 6 is an illustration of the invention wherein a film having absorber properties attached to the lid of a single use container.

**[0019]** FIG. 7 is an illustration of the invention where a ring, strip, or bead of oxygen scavenger (or carbon dioxide scavenger, humidity regulator or a combination thereof) is placed at the bottom of the container.

**[0020]** FIG. 8 is a view of a carrier containing oxygen scavenger or carbon dioxide scavenger, humidity regulator or a combination of scavengers and humidity regulators in grooves.

[0021] FIG. 9 is a cross-sectional view of the invention carrier of FIG. 8.

[0022] FIG. 10 is a cross-sectional view of the carrier of FIG. 8 with absorber in the grooves.

[0023] FIG. 11 is a cross-section view of a carrier of FIG. 9 in a container.

[0024] FIG. 12 and FIG. 13 are top and cross-section views of a carrier with a cup for containing absorber.

[0025] FIG. 14 is a cross-sectional view of a carrier with a sachet containing at least one of an oxygen scavenger, carbon dioxide absorber, or water vapor absorber.

[0026] FIG. 15 is a cross-sectional view of a ready to brew container with the carrier of FIG. 14.

[0027] In FIG. 16 and FIG. 17 it is illustrated that the edges of the carrier could be irregular.

[0028] FIG. 18 and FIG. 19 illustrates another embodiment with a concave support having an integrally molded cup.

[0029] FIGS. 20, 21, and 22 are views of alternative bottom resting carrier of the invention.

[0030] FIG. 23 is a cross-sectional view of a container with the bottom-resting carrier.

[0031] FIGS. 24 and 25 are graphs showing oxygen absorption in the Examples.

[0032] FIGS. 26 and 27 are top and bottom views of a carrier of the invention.

[0033] FIG. 28 is a cross-sectional view of the carrier of FIG. 27 on cross-section line D-D.

#### DETAILED DESCRIPTION OF THE INVENTION

[0034] The invention has numerous advantages over prior practices in the art. The invention allows the formation of packaging systems where the active component effectively maintains the freshness of the food or medical product. The invention allows the formation of single serving containers with an extended shelf life, while not changing the function or design of the containers. Further, the containers of the invention are low in cost, and the containers of the invention further may utilize biodegradable materials for the absorber and the container. The absorber may be provided in a form that is particularly desirable for different food containers depending on their need for oxygen scavenging, carbon dioxide scavenging, and/or moisture absorbing. These and other embodiments of the invention will be apparent from the detailed description and drawings below.

[0035] The phrase “mammal ingestible” is intended to include humans, pets such as dogs and cats, and farm animals. The container of the invention could contain snack drinks, medicine, and food products for non-human mammals. The non-human mammals could ingest the same or different materials as the humans.

[0036] The phrase “human ingestible material” is intended to include food, such as instant soup, instant coffee, instant fruit and vegetable juices, and instant tea; and medical products that may be drunk or ingested after being withdrawn from the container of the invention. While water is the liquid normally used to dissolve or suspend the human ingestible materials, other liquids compatible with humans, such as juice or plasma, also could be used. Further, a flavored water or water enhanced with mineral or vitamins could be used. The term “sorbent” or “absorber” is used to indicate a material that scavenges (absorbs) carbon dioxide, oxygen, or water vapor.

[0037] The formation of single serving ready-to-brew coffee that is stored in cups with lidding films is very successful. The containers used in single serve ready to brew coffee are

quite a complicated container containing a filter that holds the tea or coffee which is brewed by water passing through the top of the container and out of the bottom of the container. It is desirable to form containers that fit the thousands of ready to brew single use coffee machines for formation of other hot drinks. Costs could be lowered if the filter was not utilized. Many other hot drinks could be formed from the containers at low cost if the filter was not utilized in the container. However, as the injection of water and extraction of water in these machines is relatively rapid the materials stored in the single use containers must be capable of being rapidly dissolved or dispersed in the brief time the water is in the cup. Therefore, the materials need to maintain their particulate character and not form agglomerates, clumps, or cakes that will not be readily dispersed or dissolved. The invention provides for container with an absorber for materials that would have a deleterious effect on the particular nature of materials in the cup without a filter. Generally, many mammal indigestible materials and human digestible materials will clump, cake, or agglomerate by the action of water vapor. The absorption of these gases in the container would also generally help preserve the flavor and aroma of human indigestible materials dispensed utilizing the container. The taste is more consistent and the shelf life is longer.

[0038] The invention provides a cost-effective solution that does not require redesign of the ready-to-brew containers. Coffee machines are designed to accept cups of known design and it is not practical to change the design of the cup. Further, it is desirable that biodegradable materials be utilized as the cups are discarded after one use. The human ingestible materials that do not need to be steeped in a filter, include material such as instant coffee, instant tea, fruit and vegetable juices, cold remedies, bullion, chicken broth, some narcotics, and cocoa. These materials may leave the container either as a solution or a dispersion in the hot water.

[0039] FIGS. 1 and 2 show a top and side view of a prior art ready-to-brew coffee container 10. The container 10 has a lid 12 and exterior sides 14. During use, the lid 12 is pierced as is the bottom 16. Water is injected through the lid 12 and coffee is removed from the bottom 16. Cross-sectional line A-A is generally through the center of the container 10.

[0040] FIG. 3 is a cross-sectional view of a prior art ready-to-brew container 10. The container 10 has a filter 18 that is sealed at 22 to the sidewall of the container 14. The ingestible material level in the containers is represented by M, and in use the lid 12 of the container is pierced by means not shown and hot water is injected into the container. The bottom of the container 16 is also pierced, by means not shown, and ingestible material in water is withdrawn from the bottom. The filter divides the cup into two spaces A and B. This invention relates to improvements in the ready-to-brew coffee containers as well as other food and medicine containers in which no filter is present. In the invention structures like portions as in the prior art cup are identically numbered as in FIG. 3.

[0041] FIG. 4 illustrates an embodiment of the invention where a washer-shaped absorbent 72 is placed in a single use container. The washer-shaped absorbent has a hole 74. The container will be pierced in the portion of bottom 16 where the hole is located and the mammal ingestible fluid will drain from the container 10. The absorbent washer is a polymer that has the absorbents for at least one of water vapor, oxygen, and carbon dioxide mixed into the polymer prior to formation of the washer-shaped absorbent 72.

[0042] The washer-shaped absorbent may be made with the techniques described below. The washer and other shaped composite polymer and absorber articles below also may be formed by the technique of U.S. Pat. No. 7,595,278 to Powers, hereby incorporated by reference. Note, Examples 3 and 4 of U.S. Pat. No. 7,595,278 disclose a moisture absorbing composite material containing propylene and molecular sieve material.

[0043] FIG. 5 illustrates the cross-section of an embodiment in the invention wherein a sachet 24 has been inserted into the container 10. This sachet 24, which when oxygen absorption is desired, contains an oxygen absorber 28 such as iron in combination with salt and electrolyte. The materials in the sachet 24 will rapidly absorb oxygen during storage. The rapid absorbing of oxygen is beneficial as instant coffee and cocoa also will absorb oxygen, but the oxygen scavenger in the sachet is many times greater in rate of oxygen absorption than the instant coffee. The surface of the packet 26 is formed material that is vapor permeable but not water permeable. It maintains its integrity above the temperature of boiling water. The sachet 24 could be placed either on top of or below the material M in the container.

[0044] Alternatively or additionally, the sachet may contain a CO<sub>2</sub> absorber capable of absorbing the CO<sub>2</sub> emitted from the instant coffee or instant tea thereby minimizing loss of flavor through volatilization. It is also possible that a carbon dioxide absorbing sachet could be used in addition to the oxygen absorbing sachet. Water absorbing material could be in a sachet either alone or in addition to the other absorbers.

[0045] Alternatively or additionally, the sachet may contain a moisture regulating formulation capable of maintaining the water activity of the instant coffee, cocoa, or other food product such as instant tea, at an optimum level so that it is not too dry or too moist which can affect the extractability of the flavor elements.

[0046] In the embodiment of FIG. 6, the container has been provided with an absorber film 29 that is adhered to lid 12. The absorbent film would be adhered to the lid material 12 prior to the lid being placed on to the container. The film may be cast, laminated or extrusion coated onto the lid or preformed and attached to the lid by adhesives, ultrasonic sealing, or heat sealing. This embodiment has the advantage that absorber film is added to the lid prior to the packaging the mammal ingestible material. The absorbent film 29 may consist of multilayer structure in which the absorber is in the inner layers of the structure. The film may be provided with an abrasion resistant layer or a slippery layer, not shown, that will provide abrasion resistance or slippage so that the mammal ingestible material will not be able to remove the oxygen, carbon dioxide, and/or oxygen absorbent (scavenger) materials from the film. The resistance or slippage layer may be formed of polyethylene, polypropylene, polyamide and their copolymers. Conventional slip additives may be added into the layer that contacts the mammal ingestible material to result in a coefficient of friction of 0.5 or below, preferably 0.3 or below. The film may be an oxygen absorbing film, it is also possible that the film only contain CO<sub>2</sub> absorbing materials or only water vapor absorbing materials. It is further possible that it contain any combination of carbon dioxide, water vapor, and oxygen absorbing materials.

[0047] In the embodiment of FIG. 7, the oxygen scavenger or other absorber is placed on the bottom 16 and the bottom edge 34 of cup 10. The scavenger 32 may be placed there by a variety of techniques, but an extrusion technique, such is

utilized for hot melt adhesive would be quick and could be done during manufacturing prior to filling the container 10. A preformed scavenger ring of sorbent film also could be attached to the bottom interior edge 34 of the cup. Placement of the sorbent also could be performed by other extrusion coating methods. The extrusion materials include hot melt polymers as well as plastisol materials that would cure in place.

[0048] FIGS. 8 and 9 are a top view and a cross-sectional view of a carrier for absorber 23 for use in the container of the invention. The support has grooves 29 and 33. The support further is provided with a hole 41. In the cross-sectional view of FIG. 8, carrier 23 has been provided with a gas permeable, water impermeable cover sheet 35. Further, the grooves 29 and 33 are then filled with at least one of particulate oxygen scavenger material, carbon dioxide absorbent material, and water absorbent material. In FIG. 10 is illustrated the carrier 23 with grooves 33 and 29 filled with particulate absorber 29. The absorber 29 and carrier 23 are then covered with a sheet of material that is impervious to water but will pass gases such as oxygen and carbon dioxide. After placement on the carrier, the sheet is cut away to open the hole 41 if the sheet has not been previously cut to size. This embodiment allows the use of particulate absorber.

[0049] FIG. 11 illustrates the cross-section of an embodiment in the invention wherein a carrier 23 has been inserted in container 10. This carrier 23 contains an oxygen absorber 45 such as iron in combination with salt and electrolyte in grooves 29 and 33. The grooves 29 and 33 are covered by gas permeable and liquid water impermeable film or cloth 35. The center hole drain 36 provides for draining of the human ingestible material. Drain hole 41 is not covered by the permeable film. The materials in the grooves 29 and 33 will rapidly absorb oxygen, carbon dioxide, or water vapor during storage. The rapid absorbing of oxygen is beneficial as cocoa and instant coffee also will absorb oxygen, but the oxygen scavenger in the carrier 23 is many times greater in rate of oxygen absorption than the instant coffee. The surface film 35 is formed material that is vapor permeable but not water permeable. It maintains its integrity above the temperature of boiling water.

[0050] FIGS. 12 and 13 illustrate a carrier 40 that contains a cup 42 in the hole 41 of the carrier. The carrier 40 is provided with a multiplicity of small drain holes 44. The carrier 44 is provided with a cup 42 that fits into the hole 41. As shown in FIG. 13, the carrier has a cup 42 which is covered with a gas permeable cover 48. The cup contains at least one of a particulate oxygen scavenger, carbon dioxide scavenger, and water vapor absorber 46. The gas permeable film or cover may be formed of a gas permeable film or bonded fiber material such as Tyvek or Gore-Tex. In FIG. 14, there is illustrated a carrier containing a cup 42. A sachet 54 that contains particulate absorbent is in cup 42. The sachet is formed of a permeable film or fabric. In FIG. 15, there is illustrated the support 40 utilized in a single use container of the invention.

[0051] The carrier 40 is designed to be held by gravity in the single use coffee container 10 which narrows towards the bottom 16. It is also possible that a stop could be molded into the side of the container on which the carrier would rest. It is also possible that the carrier 40 could be held in place by adhesive. Further, it is possible that the carrier could be provided with a jagged edge or wavy edge to aid in draining of the coffee from a single use container. FIG. 16 is an illustration of

a wavy edge of a carrier **58**. FIG. **17** is an illustration of a jagged edge of a carrier **62**. It is also desirable that the grooved carrier **23** be perforated to aid in drainage. The perforation would normally need to be accomplished after the grooves have been filled and covered.

[0052] In FIG. **18** is illustrated a concave carrier **64** that has the cup **42** integrally molded with the carrier **64**. The concave carrier **64** is suspended in the package so as to be concave when viewed from the top of the package. A concave carrier may aid in centering of the carrier in the container. In the top view of a carrier such as **64** in FIG. **19** shows multiple large drain holes **66** for the liquid human ingestible material to pass through. The cup **42** may be covered with fabric after filling the particulate matter. Alternatively, the cup could contain a sachet, capsule, or polymer member comprising scavengers and/or absorbents. The cup further could have a snap fit gas permeable and liquid impermeable lid.

[0053] In FIGS. **20-22** is shown in the embodiment of carrier **70** of the invention with slots **72** for drainage. FIG. **21** is a top perspective view of the carrier and FIG. **22** is a bottom perspective view. The carrier **70** is designed to sit on the bottom of the container with the bottom **76** of the outer ring **78** on the bottom **16** of the container. The upper surface of ring **78** is surface **77**. The cup **42** may have a gas permeable film attached to surface **82** to seal in an absorber or scavenger that has placed in cup **42**. A snap cap of vapor with permeable material is a preferred embodiment. Cup **42** is provided to contain at least one of the oxygen scavenger, carbon dioxide absorber, water absorber or other treatment material for human ingestible material. A cap **82** for cup **42** alternatively may be welded to cup **42**, snapped in place, or adhesively connected. The carrier **70** further could be made with an opening and have a preformed can of treatment material bonded in place, preferably by spin welding. A gas permeable snap on cap **82** for the cup **42** is preferred for ease of formation of the carrier.

[0054] FIG. **23** is a cross-section of a container using the carrier **70**. As shown, the carrier **70** rests on the container bottom **16** with surface **76** of the carrier. The cup **42** has permeable cap **82**. The cup **42** contains absorbent members **84**. The carrier **70** does not interfere with piercing the middle of the bottom of the container **10** for drainage.

[0055] While the above illustrations have shown particulate absorbents it is also possible that the absorbents could be incorporated into a plastic film, placed in a permeable capsule or pressure formed into a tablet. The tablet then may be covered with a gas permeable film or coating. The tablets, pieces of film, extruded polymer, or sachet as illustrated could be it in the cup of the carrier.

[0056] The cup **42** is shown as a separate member that is inserted into the carrier **40**. The cup may be held in the carrier by spin welding, ultrasonic welding or pressure fitting. However, the cup in another preferred embodiment could be integrally molded with the absorber carrier. Further, it is possible that the carrier itself could be formed of a polymer that contains at least one of oxygen scavenger, carbon dioxide absorber, and dehumidifier material. If the support itself was formed of a material that absorbs oxygen and/or carbon dioxide it would only be necessary to form holes in the support for drainage and/or have irregular edge on the carrier. No cup would be necessary. Further, while the cup is illustrated in substantially the same height as the thickness of the support in several embodiments, it can be made deeper in order to hold more absorbents. Further the cup could be closed by a plug or

a fitted cover. The cup also could be a preformed gas permeable can that is bonded to the carrier.

[0057] FIGS. **26, 27**, and **28** illustrate carrier **90** as the most preferred embodiment of the invention. Carrier **90** in FIG. **26**, which is a top view, has a reinforcing ring around hole **92**. The carrier **90** has a foraminous area **102** that has holes **96** separated by pieces of polymer **104**. The holes that are in the foraminous portion **102** are numerous leaving just enough polymer **104** to support the conical shape. In use, carrier **90** sits on the bottom of the cup on the lower ring **98**. The carrier is convex as seen from the top of the container. When forming a preferred carrier for water vapor absorption, the preferred polymer is propylene blended with calcium oxide and/or molecular sieve material. The carrier **90** also could be utilized for oxygen or carbon dioxide absorption with absorbers of these gases in the polymer.

[0058] It is possible to utilize material containers for ingestible drinks that are quite permeable to gases such as oxygen, water vapor, and/or carbon dioxide. The containers are then sealed inside a bag that is impermeable to oxygen and carbon dioxide and water vapor. The bag has oxygen absorbers and/or carbon dioxide absorbers and/or water absorbers placed into the bag before it is sealed. The bag is opened immediately before use so that the ingestible drink such as cocoa does not lose freshness before use. Absorbers in the cup would prevent deterioration after the bag is opened and the individual containers are stored until use. The permeable container may be formed of a biodegradable material, such as poly lactic acid (PLA) or a copolymer of PLA and another polymer such as polyethylene or an acrylic. Alternatively, the cups could be formed of a thin, low cost or very thin polymer, permeable to oxygen, carbon dioxide, and water vapor. The bag may be foil, polyvinyl alcohol, or high-density polyethylene, preferably in layers that allow the best barrier property to be achieved in the bag.

[0059] Any suitable resin may be utilized in the invention for the polymer that holds the oxygen scavenger or other sorbent. The polymer holds the sorbent so that it will not be carried into the coffee or other food product when the container is used, but allows gas to reach the absorbent. Polymers useful for making the oxygen scavenging and absorbent articles can include common polyolefins such as low-density polyethylene (LDPE), high-density polyethylene (HDPE), polypropylene (PP), polystyrene (PS), high impact polystyrene (HIPS), polycarbonates (PC), poly(methyl methacrylate) (PMMA) and their derivatives or copolymers.

[0060] Polymers suitable for the invention and biodegradable include common polymers generated from renewable resources and biodegradable polymers such as polylactic acid copolymers, starch based polymers such as thermoplastics starch, polyhydroxyalkanoate (PHA), polyhydroxybutyrate (PHB). Biodegradable polymers that are petroleum based such as polyethylene oxide and polyvinyl alcohol (PVOH) are also included.

[0061] The invention uses common plastic article fabrication processes that include extrusion, injection molding, extrusion coating, lamination, tableting and compounding to form the sorbent structures including oxygen scavengers, CO<sub>2</sub> absorbers, and moisture regulators.

[0062] While the invention is discussed with respect to the utilization of a food container for instant coffee, instant tea, and cocoa. The concepts and container of the invention are also suitable for other uses. The containers disclosed would be suitable for use in other food products where water or other



liquids are added to the material contained in the container and wherein a changed liquid is withdrawn after dissolving or dispersing the food product. Typical of such materials would be tea, soup, milk components, and soup broth. The containers also could be used for medical products that are shipped as solid particles or are concentrated and then a carrier liquid is passed through the cup and through the concentrated liquid or solid particles to result in a medicinal liquid. An example of this would be drugs, such as powdered narcotics, such as morphine and methadone hydrochloride, and materials utilized as radiology tracers. They could also be used for alcoholic mixers.

**[0063]** The invention method of placing scavenger materials in a container, as stated above, could be used for packaging of products that are sensitive to moisture. Such products include many medicines and food products. Such food products as flour, drink mixes, gelatin desserts, and salt or other seasonings are subject to deterioration if moisture is present in the container. Moisture absorbent materials such as disclosed in U.S. Pat. No. 5,322,701-Cullen, herein incorporated by reference, could be placed into containers to enable longer storage of such materials. Suitable moisture absorbent materials include calcium oxide, silica gel, molecular sieve, and cellulose fibers.

**[0064]** The following are methods for making a solid oxygen absorbing composition or coating for use in the invention.

**[0065]** The oxygen scavenger may be in the form of a powder blend in a sachet or a pressed solid formed from compressed particles and binder. A method of making a compressed or pressed oxygen absorbing disc, tablet, wafer, washer, or capsule is as follows. Forming a blend of powdered absorbent based on iron powder with sodium chloride as an electrolyte, silica gel, and a binder that does not need to be heated very high in temperature. The binder can be a fine powdered polyethylene that will soften when under a pressure of between 3,000-50,000 pounds per square inch. The composition can also be heated to set or cure the binder but it

allowed to set or harden. This composition would be by weight about 40% thermoplastic resin, 30% iron powder, 20% silica gel, 9% water and 1% sodium chloride. An additive, such as  $\text{CaCO}_3$ , clay, or talc, could be used to increase the porosity of the resin and to increase the rate of oxygen absorption. This absorbent composition could be deposited into a container or made into a tape that could be put onto the inner sides of the container. The thermoplastic resin can be a vinyl acetate, ethyl vinyl acetate, polyurethane or combinations thereof.

**[0067]** Another method for making an oxygen absorbing composition is dispersing the oxygen absorbing composition into a polyvinylchloride plastisol. These plastisols are used as cap liners and as gaskets in caps and jar lids. This oxygen absorbing plastisol composition may then be put into the cup as a liner, a ring or coating along the sides or bottom edge of the cup. This composition would be semi liquid and could be placed into the cup and allowed to set. The plastisol may be selected from high-density polyethylene, high density polypropylene, acrylic vinyl acetate ethylene copolymer, ethylene vinyl acetate, vinyl acetate homopolymer, acetate ethylene copolymer, plasticized vinyl chloride, oxidized polyethylene homopolymer and polyurethane. The preferred plastisol is polyvinyl chloride as it does not react with foods and is resistant to the temperature of boiling water. The oxygen absorption composition can be up to 75% by weight with the other 25% being the polymer. One composition was 10.35 grams of polyvinylchloride plastisol, 12.51 grams of iron powder containing 2% by weight sodium chloride.

**[0068]** Illustrative of a plastisol material is polyvinyl plastisol in an amount of 10.35 grams was blended with 12.51 grams of 200 mesh iron powder containing 2% by weight sodium chloride. The blending was done with an electric high-speed mixer. A sample of the resulting composition was coated onto a container cap. The rate of oxygen absorption was measured over time.

	Sample 1	Sample 2	Sample 3	Sample 4
Composition weight	1.47 grams	1.71 grams	1.51 grams	1.56 grams
CC of oxygen absorbed after 22 hours	10.	10.	10.	10.
CC of oxygen absorbed after 46 hours	15.	14.	15.	15.
CC of oxygen absorbed after 96 hours	24.	22.	24.	23.
CC of oxygen absorbed after 184 hours	37.	32.	37.	35.
CC of oxygen absorbed after 234 hours	37.	32.	37.	35.
CC of oxygen absorbed after 330 hours	51.	41.	48.	47.

cannot be heated above the boiling point of water to keep the moisture in the carrier. A suitable composition by weight would be about 18% polyethylene, 40% iron powder, 30% silica gel, 8% water and 2% sodium chloride. It is best to use a resin binder with a softening point above the boiling temperature of water.

**[0066]** A method for making an oxygen absorbing compound would be to put the oxygen absorbing composition in a thermoplastic material so that the oxygen absorbing compound could be filled into a container as a liquid ring and

**[0069]** The test vessel contained 500 cc of air or 100 cc of oxygen. The test was conducted at room temperature with a moisture source in the test vessel.

**[0070]** Another invention composition would be to disperse the sorbent composition in a multiple component carrier such as an emulsion, dispersion, suspension or other mixtures. By dispersing the sorbent in such a multi component system the resulting composition can be more easily applied to a cup as an oxygen scavenger or sorbent coating. These types of coatings can contain more of the oxygen absorbing composition

and have greater permeability for oxygen. By not fully drying the water based systems we can have a self activation and self reacting oxygen absorbing coating. Glucose oxidase can be used in place of the iron. A xanthan gum emulsion, alginate emulsion or microcrystalline cellulose system can also be used. This system can also contain water in the iron based oxygen absorbing system. Adhesive based emulsion can also be used such as acrylic polymer emulsions in water, a polyvinyl acetate in water emulsion, and a vinyl acetate ethylene copolymer in water emulsion can be used. The oxygen absorbing composition would be an iron powder with sodium chloride as an electrolyte and a moisture carrier. The moisture carrier can be silica gel, hydrogel or any other moisture carrier that can hold moisture. In oxygen absorbers, it is also possible to not fully dry the moisture out of the emulsion thereby leaving some moisture in the coating. An alginate gel would be by weight percent 2.25% sodium alginate, 1.0% polysorbate 80, 0.2% sodium propionate and 96.55% distilled water. A xanthan gum emulsion would be by weight 2.0% xanthan gum, 43% isopropyl alcohol and 55% water. These two emulsions could be combined 1 part emulsion with 1 part oxygen absorbing composition composed of 99% iron powder and 1% sodium chloride as the electrolyte. The oxygen absorbing composition can be a fine iron as fine as 2-5 microns in particle size to improve the clarity of the oxygen absorbing coating or oxygen absorbing compound. A thin film layer or coating can be put over the final coating to insure that no oxygen absorbing ingredients or sorbents migrate out over time. This thin film cover can be a cellulose acetate polymer, vinyl acetate ethylene copolymer, vinyl acetate homopolymer, acetate ethylene copolymer, plasticized vinyl chloride polymer, acrylic polymer or an oxidized polyethylene homopolymer.

**[0071]** The water absorbers and carbon dioxide absorbers may be placed into the polymer by a substitute for the oxygen absorbers. The preferred water vapor absorbers are silica gel and molecular sieve materials.

**[0072]** Any suitable transition metal, typically including zinc, copper, iron, cobalt and zirconia, may be utilized in the oxygen scavenger of the invention. The preferred oxygen scavenger of reduced iron powder preferably has 1-200 um mean particle size, more preferably 5-50 um mean and most preferably 10-40 um mean. The iron can be mixed with salt or a combination of different electrolytic and acidifying components. The iron particles can, in a preferred embodiment, also be coated with electrolyte salt. The combination and relative fraction of activating electrolytic and acidifying components coated onto the iron particles can be selected according to the teachings of U.S. Pat. No. 6,899,822 and co-assigned published U.S. Patent Applications 2005/0205841 and 2007/020456, incorporated herein by reference. The coating technique is preferably a dry coating process as described in the references above.

**[0073]** The salt can be any salt such as sodium, potassium or calcium based ionic compounds that are soluble in water. Typical examples include NaCl, KCl, Na<sub>2</sub>HPO<sub>4</sub> and others. A mixture of separate electrolytic and acidifying salt components can be advantageously used in the formulation as described in prior art. Sodium chloride is preferred because it is effective and low in cost.

**[0074]** The oxygen scavenging fabricated article may contain moisture regulators based upon silica gel, molecular sieve, activated carbon, clay or other minerals. The com-

pounds may contain various levels of water to achieve water activities ranging from 0.01 to 0.85.

**[0075]** The film/tape/ribbons/wafers/washers used in the invention may be a single or multilayer films that are porous or solid, and consisting of iron-based oxygen scavengers and electrolytes, such as disclosed in co-assigned U.S. patent application Ser. No. 12/416,685, filed Apr. 1, 2009, hereby incorporated by reference and U.S. Patent Publication No. 2010-0255231, published Oct. 7, 2010, also hereby incorporated herein by reference. The film optionally consists of moisture regulators with a chosen water activity. The film may be in circular or strips that can be fitted into a container as a bent strip. Multilayer film is preferred with oxygen scavenger or other absorber embedded inside the film and not exposed on film surface. Films with some porosity or voids are preferred to facilitate the rate of oxygen, carbon dioxide, or water vapor absorption. Moisture regulator can be incorporated into the film during extrusion or from post-extrusion processing. The films can be laminated to the lids or container sides.

**[0076]** The insert may be a ring shaped oxygen scavenging article as in FIG. 4 with a ring diameter smaller than the bottom of the container such that the insert can be laid flat inside the container. The insert can be fabricated by die-cut from the films above or by other fabrication means such as injection molding and compression molding

**[0077]** In the embodiment using strands/paste, such as in FIG. 7 or in cup 42, a section of elongated or shaped oxygen scavenging material that consists of oxygen scavenger, salt and moisture regulators may be utilized. A method of making such a strand is by melt extrusion. The polymer may be polyethylene, wax, polyethylene glycol, cellulosic polymers, polylactic acid, and starch-based copolymers. The moisture regulator may be salts, silica gel, clay, molecular sieve or like that contains certain levels of moisture.

**[0078]** A method to remove CO<sub>2</sub> in the package is described as follows: using a scavenger specifically designed for CO<sub>2</sub> absorption. A packet made of a gas permeable polyolefin film containing carbon dioxide absorbing particulates is packaged in a single use container to absorb the off-gasses. The preferred packet will have high gas permeation and low water vapor permeation properties. The absorber will be capable of absorbing a high concentration of CO<sub>2</sub> and not interfere with the aromatics components of the human ingestible material. The CO<sub>2</sub> absorber can contain certain amount of calcium hydroxide, silica gel and water, with other ingredients. Optionally calcium hydroxide may be replaced with other hydroxides such as sodium hydroxide and potassium hydroxide or mixtures of these and other hydroxides. Optionally, alkaline, alkaline earth or metal oxides may be used in conjunction with or replacing hydroxides. The oxides include but not limited to calcium oxide, aluminum oxide and magnesium oxide. These oxides may be used in mixture format. For reference, the range and formulations useful as CO<sub>2</sub> absorber are described in U.S. Pat. No. 5,322,701 assigned to Multi-form Desiccants, Inc., hereby incorporated by reference.

**[0079]** As described for the oxygen absorbing materials above the oxygen and carbon dioxide scavenging formulations may be packaged in a format other than a packet. The carbon dioxide scavenging formulations may be enclosed in oxygen or carbon dioxide permeable capsule or a tablet that may be coated with a permeable or semi-permeable polymer material. Any resin or polymer permeable to oxygen and/or carbon dioxide may be used to coat the tablets. Water base

polymer coating of the tablets is preferred. Preferred coating polymers are hydroxyl propylmethyl-cellulose or acrylic water base coatings. They may also be fabricated in a compact form, such as a washer, wafer, disc or platelet, wrapped with a coating or polymer film that is gas permeable or semi-permeable. The coating method of making the disc, platelet or tablet can include dip coating, spray coating, flash coating, spin coating or any other known methods that are applicable to forming the product. The film method can include over-coating, lamination, multilayer lay up followed by die-cutting, and any other known methods that can make film composite layered articles. The methods of forming oxygen absorbents above may be used for forming sorbent materials for CO<sub>2</sub> absorbents and water vapor absorbents.

**[0080]** Alternatively or additionally, the sachet, grooves, film, or cup may contain a CO<sub>2</sub> absorber capable of absorbing the CO<sub>2</sub> emitted from the coffee permitting it to be packaged a short time after roasting thereby minimizing loss of flavor through volatilization. It is also possible that a carbon dioxide absorbing sachet could be used in addition to the oxygen absorbing sachet.

**[0081]** Alternatively or additionally, sachet, the grooves, film or cup may contain a moisture regulating formulation capable of maintaining the water activity of the instant coffee or other food product such as instant tea, at an optimum level so that it is not too dry or too moist which can affect the extractability of the flavor elements.

**[0082]** The container may be provided with an oxygen absorbent film or other sorbent film that is in cup 42. The film may be cast, laminated or extrusion coated into the cup or preformed and attached to the cup by adhesives, ultrasonic sealing, or heat sealing. The oxygen absorbent film may consist of multilayer structure in which the oxygen absorbent is in the inner layers of the structure. The film may be provided with an abrasion resistant layer or a slippery layer, not shown, that will provide abrasion resistance or slippage so that the filter's movement will not be able to remove the oxygen absorbent (scavenger) materials from the film. The resistance or slippage layer may be formed of polyethylene, polypropylene, polyamide and their copolymers. Conventional slip additives may be added into the layer that contacts the coffee to result in a coefficient of friction of 0.5 or below, preferably 0.3 or below. While described with reference to an oxygen absorbing film, it is possible that the film only contain CO<sub>2</sub> absorbing materials, or water absorbing materials. It is further possible that it contain a combination of carbon dioxide, oxygen absorbing, and water absorbing materials.

**[0083]** The oxygen scavenger or other gas absorber may be placed in cup 42 by a variety of techniques, but an extrusion technique, such is utilized for hot melt adhesive is quick and may be done during manufacturing prior to the support 40 being put in the cup. The extrusion materials include hot melt polymers as well as plastisol materials discussed above that would cure in place.

**[0084]** Any suitable resin may be utilized in the invention for the carrier and the absorbent film polymer that holds the oxygen scavenger, carbon dioxide absorbent, water vapor absorber, or other sorbent. The polymer holds the sorbent so that it will not be carried into the instant coffee, cocoa, or other food product when the container is used. Polymers useful for making the oxygen scavenging and absorbent articles can include common polyolefins such as low-density polyethylene (LDPE), high-density polyethylene (HDPE), polypropylene (PP), polystyrene (PS), high impact polysty-

rene (HIPS), polycarbonates (PC), poly(methyl methacrylate) (PMMA) and their derivatives or copolymers.

**[0085]** Polymers suitable for the invention container and carriers and biodegradable include common polymers generated from renewable resources and biodegradable polymers such as polylactic acid copolymers, starch based polymers such as thermoplastics starch, polyhydroxyalkanoate (PHA), polyhydroxybutyrate (PHB). Biodegradable polymers that are petroleum based such as polyethylene oxide, polyvinyl alcohol (PVOH) are also included.

**[0086]** The invention uses common plastic article fabrication processes that include extrusion, injection molding, extrusion coating, lamination, tableting and compounding to form the sorbent structures including oxygen scavengers, CO<sub>2</sub> absorbers, and moisture regulators.

**[0087]** The oxygen scavenging fabricated article may contain moisture regulators based upon silica gel, molecular sieve, activated carbon, clay or other minerals. The compounds may contain various levels of water to achieve water activities ranging from 0.01 to 0.85. In the event that only protection from deterioration of the mammal ingestible material by action of water vapor is desired the n the absorber and moisture regulator silica gel, molecular sieve, activated carbon, clay, or other minerals may be used without the oxygen scavenger or carbon dioxide absorber. Silica gel is preferred as it is low in cost, effective, and safe. Moisture absorbent materials such as disclosed in U.S. Pat. No. 5,322,701—Cullen, herein incorporated by reference, could be placed into containers to enable longer storage of moisture sensitive materials.

**[0088]** The film/tape/ribbons for use in cup 42 of the invention may be a single or multilayer films that are porous or solid, and consisting of iron-based oxygen scavengers and electrolytes, such as disclosed in co-assigned U.S. patent application Ser. No. 12/416,685, filed Apr. 1, 2009, hereby incorporated by reference. The film optionally consists of moisture regulators with a chosen water activity. Multilayer film is preferred with at least one of water vapor absorber, carbon dioxide absorber, or oxygen scavenger embedded inside the film and not exposed on film surface. Films with some porosity or voids are preferred to facilitate the rate of absorption. Moisture regulator can be incorporated into the film during extrusion or from post-extrusion processing.

**[0089]** The following examples are used to illustrate some parts of the invention. The Examples are illustrative and not exhaustive of the embodiments of the invention. Parts and percentages are by weight unless otherwise indicated. The examples use ground coffee as the test material to show the oxygen scavenging effectiveness. As they are effective with ground coffee, they will also be effective in the container of the instant invention.

#### Example 1

##### Oxygen Scavenging Films Packaged with Coffee

**[0090]** An extruded film that contained oxygen scavenger formulations was prepared by following a method described in co-assigned U.S. patent application Ser. No. 12/416,685, filed Apr. 1, 2009, hereby incorporated by reference, to test the oxygen scavenging behavior with the presence of coffee. The film was extruded from a mixture of 17/3/80 weight ratio of iron, sodium chloride and low density polyethylene from a film extrusion process. The materials were pre-mixed in a container and fed into a twin screw extruder with the extruder

and die temperatures set at 220° C. Films, approximately 9 mil thick, were extruded from a 6" die and collected on a spool. The 9 mil film samples, cut in approximately 1" square pieces, were moisturized by placing drops of water on the surface of the film and blotted to remove dripping water. The films were placed in 7"×7" plastic barrier bags with a package of approximately 8.8 gm ground coffee sealed in Tyvek breathable film bag. The barrier bag was hot sealed and injected with 150 cc O<sub>2</sub>/N<sub>2</sub> mixture to reach an initial oxygen concentration of 3% or lower. The oxygen scavenging rate was measured by using MOCON PacCheck Model 450 Head Space Analyzer.

#### Example 1A

##### Coffee without Oxygen Scavenger

**[0091]** As a control, a separate barrier bag that consists of approximately 8.8 gm ground coffee removed from a container, conditioned in ambient temperature and environment for more than one hour, was sealed in Tyvek breathable film bag without scavenger, and was tested for oxygen concentration change over the same time period.

**[0092]** FIG. 24 shows the results of oxygen concentration change with time for two different scavenger loadings. The oxygen scavenging rate increases with the net amount of the scavengers used. In 88 hrs, a sample with a starting O<sub>2</sub> of 1.98% dropped to 0.04% with 0.52 gm of the scavenger in the film. A sample of 2.21% O<sub>2</sub> dropped to 1.08% with 0.17 gm of the scavenger in the film. The O<sub>2</sub> concentration of a sample with coffee packet only without scavenger dropped from 2.45% to 2.37% with some variation over the same time period. This example demonstrated that the scavenger gives much higher oxygen absorption rate than the combination of coffee and the background materials. The oxygen scavenging capability can be adjusted by the amount of the scavenger used and the preparation method adopted.

#### Example 2

##### Oxygen Scavenging Film Laminated on Coffee Lidding

**[0093]** Oxygen scavenging film was extruded with a mixture of 5.1/0.9/94 weight ratio of iron/NaCl/PLA in which PLA was NatureWorks PLA 2002D resin. The iron is the same as in Example 1. The composition of poly (lactic acid) resin (PLA) was pre-dried in a desiccant oven at 60° C. for at least 4 hrs before extrusion. The mixture was extruded in a twin screw extruder to make 4" wide and 4 mil thick films. A coffee lidding foil film peeled from a Green Mountain 55 cc cup coffee was used for lamination test. Dow Chemical Integral™ 801 adhesive film was used as an adhesive for lamination test. The extruded Fe/PLA film was stacked with the Integral film and the lidding film to form Fe/PLA-adhesive-lidding sandwich structure. The structure was heat pressed in a heat sealer to form an oxygen-scavenging lidding structure.

#### Example 3

##### Oxygen Scavenging Sachet Packaged with Coffee

**[0094]** Packets with an approximate size of 1"×0.5" made of a polyolefin film containing iron-based oxygen scavenging formulation and moisture regulator were used for the test. The packets contained iron-based scavenger and a moisture retaining material patented by Multisorb Technologies. The

packet consists by weight of approximately 40% iron, 10% NaCl, 50% silica gel and some moisture. The packets had a water activity in the range of 0.4-0.8. The packets were stored with coffee in 150 cc barrier bag and tested as described in Example 1. The oxygen absorption property was measured by using MOCON PacCheck Model 450 Head Space Analyzer. FIG. 25 shows the oxygen scavenging result that demonstrated that the oxygen concentration decreased rapidly with time. The scavenging rate is much faster than the oxygen absorption rate of the coffee and the background material as shown in Example 1.

#### Example 4

##### Oxygen Scavenging Acrylic Coating Preparation

**[0095]** An acrylic emulsion was made using Neocryl A-5117 from Zeneca Resins. A formulation comprising 50 weight percent of this acrylic emulsion and 50 weight percent of a 200 mesh electrolytic iron reduced iron containing 2 weight percent sodium chloride was coated on eight square inches of a polypropylene substrate and dried with heat. The coat weight was 0.0135 grams per square inch. This oxygen absorbing coating was then placed inside of a test vessel with 500 cc of air or 100 cc of oxygen along with 2 square inches of a moisture saturated blotter paper. Three samples were tested.

	Sample 1	Sample 2	Sample 3
Composition weight	1.47 grams	1.71 grams	1.51 grams
CC of oxygen absorbed after 48 hours	13.	16.	15.
CC of oxygen absorbed after 114 hours	13.	18.	15.

#### Example 5

##### Oxygen Scavenging Polyvinyl Acetate Coating Preparation

**[0096]** A polyvinyl acetate in water emulsion was made using Vinac XX-210 from Air Products. Forty three weight percent of this polyvinyl emulsion was combined with 57 weight percent iron blend containing 200 mesh electrolytic reduced iron powder containing 2 weight percent of sodium chloride. This formulation was then coated on to eight square inches of a polypropylene substrate with a coat weight of 0.026 grams per square inch. The resulting coating was then placed inside of a test vessel with 500 cc of air or 100 cc of oxygen. A moisture source was also placed inside of the test vessel along with the sample. Three samples were tested.

	Sample 1	Sample 2	Sample 3
Composition weight	1.47 grams	1.71 grams	1.51 grams
CC of oxygen absorbed after 48 hours	22.	22.	22.
CC of oxygen absorbed after 114 hours	25.	25.	25.

## Example 6

## Extruded Carbon Dioxide Scavenging Sheets

[0097] VitaCal-H calcium hydroxide ( $\text{Ca}(\text{OH})_2$ ) powder was obtained from Mississippi Lime Company. The as received powder was mixed with ground silica gel (SG) powder that had a mean particle size of approximately 6 micron with a by weight mixture ratio of VitaCal-H/SG=75/25. The mixture was then blended with Petrothene GA502024 low density polyethylene resin obtained from LynodellBasell Industries to achieve the following blend weight ratios:  $\text{Ca}(\text{OH})_2/\text{SG}/\text{LDPE}=30/10/60$  and  $40/10/50$

[0098] The blends were extruded in a single screw extruder with a flat sheet die attached to the extruder to make sheet materials. SAFOAM FPN3-40 obtained from Reedy International Co. was added in some runs to make samples that contained some voids or porosity. The extruder was set at 160-220° C. temperature range and the die was at 220° C. The extruded sheets, approximately 30-40 mil thick, were air cooled and wound on a roll.

[0099] Samples, approximately 0.4-0.7 grams were cut from the extruded sheets and used for carbon dioxide scavenging test. The samples were pre-hydrated with water to obtain approximately 1 to 5% water content determined by weight gain. The samples were then sealed in foil pouches filled with 600 cc gas that contained approximately 25-20% carbon dioxide balanced with nitrogen. The concentration of carbon dioxide was measured using a MOCON model 333 Pac-Check analyzer for various periods of time. The scavenging test data in terms of cc of  $\text{CO}_2$  absorbed is shown in Table-1. The formulations listed are weight ratios of  $\text{Ca}(\text{OH})_2/\text{SG}/\text{LDPE}$ . Safoam was added as additional percentage. The data showed that carbon dioxide was absorbed effectively with the increase of time from 24-72 hrs.

TABLE 1

CO <sub>2</sub> absorption of extruded sheets							
ID	Formulation*	Safoam+, %**	Weight, gm	0 hrs	24 hrs	48 hrs	72 hrs
				CO <sub>2</sub> absorbed, cc			
1	30/10/60	5	0.69	0	6.82	12.7	17.2
2	30/10/60	2	0.66	0	6.94	12.8	20.1
3	40/10/50	0	0.57	0	7.7	12.9	20.6
4	40/10/50	5	0.48	0	9.96	11.2	17.8

\*Formulation ratio =  $\text{Ca}(\text{OH})_2/\text{SG}/\text{LDPE}$  by weight

\*\*Percent by weight of formulation

+safoam FPN 3-40 at hydrofluocarbon

## Example 7

## Injection Molded Carbon Dioxide Scavenging Discs

[0100]  $\text{Ca}(\text{OH})_2$  and silica gel used were the same as that of Example 7. Solka-floc wood fiber was obtained from International Fiber Company. Polypropylene was Sunoco CP360H resin, an elastomer Kraton G1657 was obtained from Kraton Polymers. These materials were blended to form the following material weight ratios:  $\text{Ca}(\text{OH})_2/\text{SG}/\text{Solka-floc}/\text{PP}/\text{Kraton 1657}=48/6/6/36/4$

[0101] The materials were compounded in a twin screw compounding machine at 200-250 C temperature and extruded into strands, cooled in water and pelletized. The compounded pellets were injection molded in a single shot injection molding machine to form 1.3" diameter discs. The

discs were tested for carbon dioxide scavenging performance following the procedure described above. The test data showed that the discs gradually absorbed carbon dioxide with the test time. The absorbing rate was found increased when the disc surfaces were roughened with a sand paper prior to hydration. Table-2 shows the data of an injection molded disc, sanded and hydrated with 1% water prior to test.

TABLE 2

CO <sub>2</sub> absorption of injection molded discs						
ID	Disc weight, gm	% hydration	0 hrs	96 hrs	120 hrs	144 hrs
			CO <sub>2</sub> absorbed, cc			
Sanded disc	1.2	1.0	0	25.7	27.5	29.9

## Example 8

## Coated Carbon Dioxide Scavenging Paperboard

[0102] Coating formulations were prepared by using the same sorbent ingredients as described above. Luvitec K30 (BASF) polyvinylpyrrolidone (PVP) and polyethylene glycol 6000 (Aldrich Chemical) were used to make the coating solutions. PVP was dissolved in water to form a 17 wt % solution. PEG was dissolved in water to form a 48 wt % solution. Both solutions were clear and without residues. A mixture of the PEG and PVP solutions was made with 90/10 ratio to achieve a resin content of approximately 45% in water. The solutions were used to mix with  $\text{Ca}(\text{OH})_2$  and SG to form a coating solution that has the following coating formulation:  $\text{Ca}(\text{OH})_2/\text{SG}/(\text{PEG}/\text{PVP})=40/10/50$

[0103] The solutions were coated on an 20 mil paperboard substrate and dried in oven at 115 C for more than 2 hours to remove the water. The coated samples were cut and hydrated with wet sponge to be used for carbon dioxide scavenging test by using the same test method described above. The test data is shown in Table-3. It is seen that carbon dioxide was absorbed rapidly over the test time period.

TABLE 3

CO <sub>2</sub> absorption of $\text{Ca}(\text{OH})_2$ -coated paperboard coupons					
ID	Coating weight, gm	% hydration	0 hrs	24 hrs	96 hrs
			CO <sub>2</sub> absorbed, cc		
100710-1	1.21	1.2	0	4.8	27.1
100710-2	1.44	4.0	0	15.8	50.5

[0104] Another coating solution was prepared by dissolving hydroxypropylcellulose resin (Hercules Klucel EF) in water to form a uniform solution.  $\text{Ca}(\text{OH})_2$  and SG were mixed with the solution to form a paste formulation approximately  $\text{Ca}(\text{OH})_2/\text{SG}/\text{Klucel}=70/10/20$  weight ratios. Klucel served as a binder for the solid formulation. The paste formulation was pressed on the same paperboard and dried to form a porous coating. The pressed-coating, although brittle, maintained integrity for test. It was hydrated with wet sponge and the weight gain was recorded. This high solid loading sample was tested for  $\text{CO}_2$  scavenging performance. The data in Table-4 showed that  $\text{CO}_2$  was absorbed rapidly over the test time period with high absorption capacity.

TABLE 4

CO <sub>2</sub> absorption of Ca(OH) <sub>2</sub> -coated paperboard with high solid loading					
ID	Coating weight, gm	% hydration	0 hrs CO <sub>2</sub> absorbed, cc	24 hrs	336 hrs
093010-1	0.52	5	0	67.3	86.8

## Example 9

## Capsule Filled with Carbon Dioxide Absorber Blend

[0105] Plastic capsules were hand filled with Multisorb Technologies  $\text{CO}_2$  absorbing formula (semi-dry flow able granules) to achieve a  $\text{CO}_2$  free environment. The capsules are breathable, semi-rigid, and are partially resistant to hot water. The device (capsule) provides for a timed absorption of  $\text{CO}_2$  from coffee filled pods stored at various temperatures. The  $\text{CO}_2$  capsule limits the expansion of a non-breathable cup (from  $\text{CO}_2$  emissions from coffee) and also enhances or maintains the aromas and oils of the freshly roasted coffee powders and granules. The formulation enclosed in the capsules were  $\text{Ca}(\text{OH})_2/\text{SG}=67/33$  ratio with the silica gel containing water. The net formulation was  $\text{Ca}(\text{OH})_2/\text{SG}/\text{H}_2\text{O}=67/20/13$  weight ratio. The blend was in loose powder format contained in the capsule. The  $\text{CO}_2$  scavenging data is shown in Table-5.

TABLE 5

CO <sub>2</sub> absorption of Ca(OH) <sub>2</sub> filled capsule					
ID	Coating weight, gm	% hydration	0 hrs CO <sub>2</sub> absorbed, cc	72 hrs	240 hrs
Caplug	0.65	30	0	32.6	36.4

## Example 10

Tablets made of CO<sub>2</sub> Scavengers

[0106] The formulation used in Example 10 was compressed into tablets in a mold on a conventional cold or hot pressing machine. The tablets were then coated with polyethylene powders on the surface. The coated tablets were heated in a heating chamber at a temperature below the melting point of polyethylene but hot enough to fuse the coated powder particles. The coated tablets were conditioned at room temperature in 80% relative humidity environment for 16 hrs. The tablets showed  $\text{CO}_2$  scavenging properties as listed in Table-6.

TABLE 6

CO <sub>2</sub> absorption of Ca(OH) <sub>2</sub> filled tablets						
ID	Coating weight, gm	% hydration	0 hrs	24 hrs	48 hrs	72 hrs
5%-S2	0.85	5	0	11.3	14.9	17.3

## Example 11

Sintered Structure Carbon Dioxide Scavenging Disc/  
Component

[0107]  $\text{Ca}(\text{OH})_2$  and silica gel used were the same as that of Example 7. Solka-floc wood fiber was obtained from International Fiber Company. Polypropylene was Sunoco CP360H resin, an elastomer Kraton G1657 was obtained from Kraton Polymers. These materials were blended to form the following material weight ratios:  $\text{Ca}(\text{OH})_2/\text{SG}/\text{Solka-floc}/\text{PP}/\text{Kraton 1657}=48/6/6/36/4$

[0108] The materials were compounded in a twin screw compounding machine at 200-250 C temperature, cooled in water and pelletized. The pellets will then be ground to relatively small particle size which will then expose portions of the active ingredients. This exposure will increase the adsorption rate. The ground active material is then fused together under heat and pressure which is applied to the material in a mold. The results are a porous sintered structure that increased active surface area.

[0109] The materials of the above Examples 1-11 may be utilized in the invention as scavengers or absorbents. Water vapor absorbers could be made by similar techniques using silica gel and molecular sieve materials.

[0110] The invention has been described in detail with particular reference to a presently preferred embodiment, but it will be understood that variations and modifications can be effected within the spirit and scope of the invention. The presently disclosed embodiments are therefore considered in all respects to be illustrative and not restrictive. The scope of the invention is indicated by the appended claims, and all changes that come within the meaning and range of equivalents thereof are intended to be embraced therein.

1. An extended shelf life single portion package comprising a container having therein a material for mammal ingestion that degrades by exposure to oxygen, water vapor, or carbon dioxide, an absorber selected from at least one of a carbon dioxide absorber, water vapor absorber, and oxygen scavenger wherein the container is substantially impervious to oxygen, carbon dioxide, and water vapor.

2. The package of claim 1, wherein the container holds a carbon dioxide absorbent.

3. The package of claim 2, wherein carbon dioxide absorbent produces water when absorbing carbon dioxide.

4. The package of claim 1, wherein the oxygen scavenger is present in the container and comprises a transition metal that is elemental iron and the oxygen scavenger is water activated.

5. The package of claim 1, wherein the material for mammal ingestion comprises a food product selected from the group consisting of instant coffee, instant tea, cocoa, and dry milk products.

6. The package of claim 4, wherein the rate of absorption of oxygen by the scavenger is many times that of the food product.

7. The package of claim 1, wherein oxygen scavenger is present in the container.

8. The package of claim 7, wherein the mammal is human.

9. The package of claim 8, wherein the oxygen scavenger comprises sodium chloride.

10. The package of claim 1, wherein the container holds instant coffee, instant tea, or cocoa.

11. The package of claim 1, wherein the container comprises an oxygen impermeable lid.

12. The package of claim 2, wherein the container has therein a carbon dioxide absorbent comprising calcium hydroxide or magnesium hydroxide.

13. The package of claim 12, wherein the container has therein an oxygen scavenger that contains calcium oxide or magnesium oxide powder and water in silica gel that react to produce calcium hydroxide.

14. The package of claim 1, wherein the container has a lid and an oxygen scavenger is attached to the lid of the container.

15. The package of claim 1, wherein an oxygen scavenger is attached to the walls of the container.

16. The package of claim 1, wherein an oxygen scavenger is contained in a polymer film or strip.

17. The package of claim 1, wherein the absorber is formulated with polymer as a disc, tablet or capsule.

18. The package of claim 1, wherein the container has an absorber in a sachet that is permeable to oxygen and impervious to liquid water.

19. The package of claim 17, wherein the absorber is in the shape of a washer on the bottom of the container.

20. The package of claim 1, wherein the container holds a water vapor absorber.

21. The package of claim 20, wherein the absorber is a carbon dioxide absorber.

22. The package of claim 1, wherein the mammal ingestible product is selected from the group consisting of instant coffee, instant tea, cocoa, and milk products.

23. The package of claim 1, wherein the container does not have a filter.

24. The package of claim 1, wherein the container has a carrier for the absorber that is concave in shape when viewed from the top of the package.

25. The package of claim 24, wherein the carrier for the absorber comprises a polymer containing oxygen scavenger particles.

26. The package of claim 1, wherein the absorber is in a carrier that is convex as viewed from the top of the container and rests on the bottom of the container.

27. The package of claim 2, wherein the carbon dioxide absorbent comprises calcium hydroxide or magnesium hydroxide.

28. The package of claim 1, wherein the absorber is an oxygen scavenger comprising calcium oxide or magnesium oxide powder and water in silica gel that react to produce calcium hydroxide.

29. The package of claim 1, wherein the absorber is in a carrier that comprises a cup and has an oxygen scavenger in the cup.

30. The package of claim 29, wherein the oxygen scavenger comprises absorbent particles and the cup has an oxygen permeable cover.

31. The package of claim 1, wherein the absorber is an oxygen scavenger in a sachet that is permeable to oxygen and impervious to liquid water.

32. The package of claim 21, wherein the water absorber is silica gel or molecular sieve.

33. The package of claim 26, wherein the carrier comprises a blend of polymer and water absorber.

34. The package of claim 33, wherein the water absorber is selected from the group of calcium oxide, silica gel, and molecular sieve.

35. The package of claim 34, wherein the convex carrier has an opening in the center and foraminous sides.

\* \* \* \* \*