



(19) **United States**

(12) **Patent Application Publication**
Higa et al.

(10) **Pub. No.: US 2011/0240185 A1**

(43) **Pub. Date: Oct. 6, 2011**

(54) **LEAD-FREE NANOSCALE
METAL/OXIDIZER COMPOSITE FOR
ELECTRIC PRIMERS**

Publication Classification

(51) Int. Cl.	
<i>C06B 45/30</i>	(2006.01)
<i>C06B 45/34</i>	(2006.01)
<i>C06B 33/08</i>	(2006.01)
(52) U.S. Cl.	149/7; 149/5; 149/38

(76) **Inventors:** **Kelvin T. Higa**, Ridgecrest, CA (US); **Steve Son**, Los Alamos, NM (US); **Tom Doris**, Sparta, NJ (US); **Stephen Fallis**, Ridgecrest, CA (US)

(57) **ABSTRACT**

A lead-free electric primer composition including a mixture of at least one metal having nanometer-sized particles with at least one oxidizer having nanometer-sized particles producing a metal(s)-oxidizer(s) nanocomposite, wherein the oxidizer(s) is present in an effective amount to substantially oxidize the metal(s), at least one gas generating material mixed with the metal(s)-oxidizer(s) nanocomposite producing a metal(s)-oxidizer(s)-gas generator(s) composition, at least one binder, the metal(s)-oxidizer(s)-gas generating composition is coated with the binder, and at least one conductive material.

(21) **Appl. No.: 12/122,918**

(22) **Filed: May 19, 2008**

Related U.S. Application Data

(63) Continuation of application No. 10/956,530, filed on Sep. 22, 2004, now abandoned.

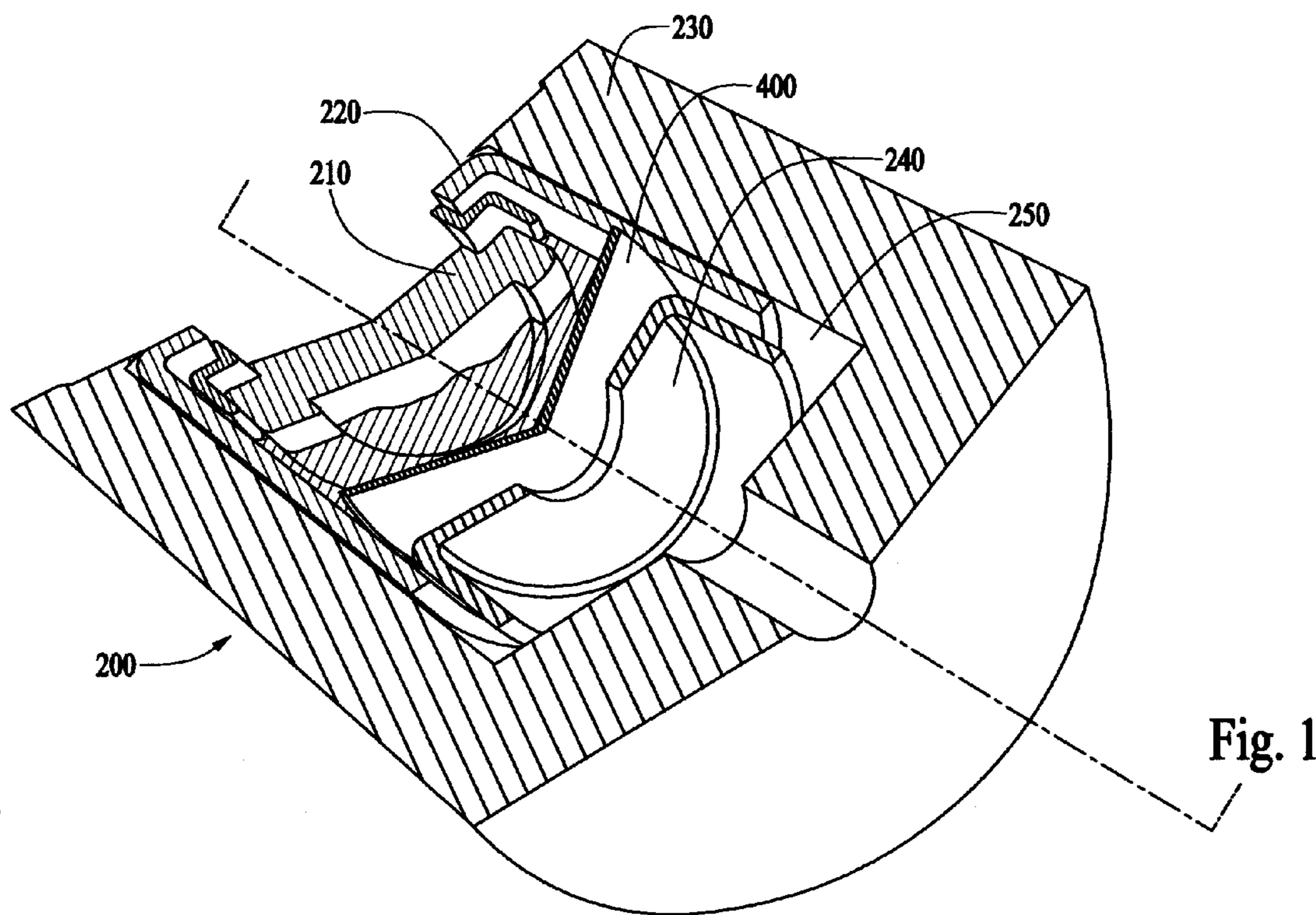
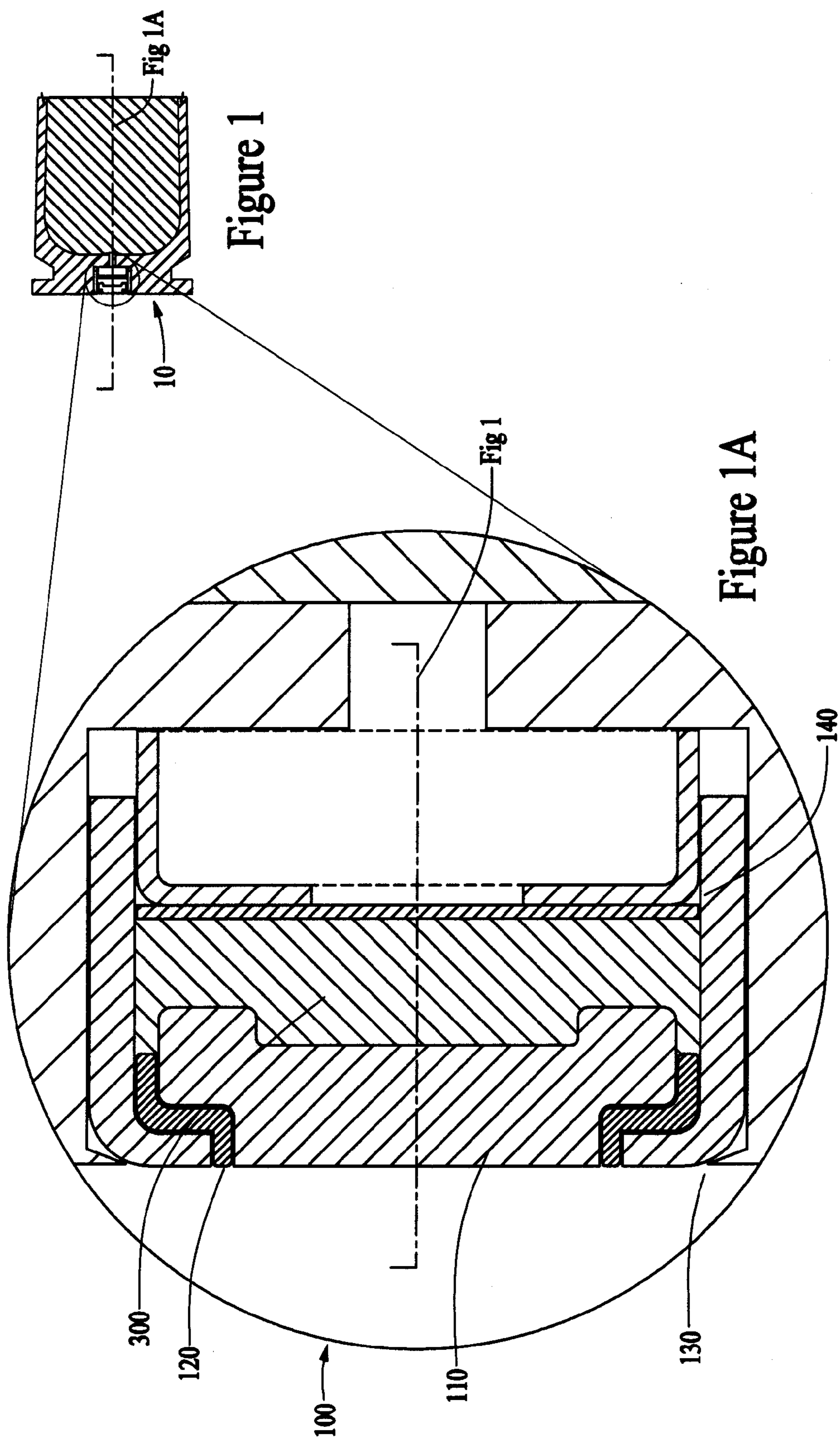

Fig. 1



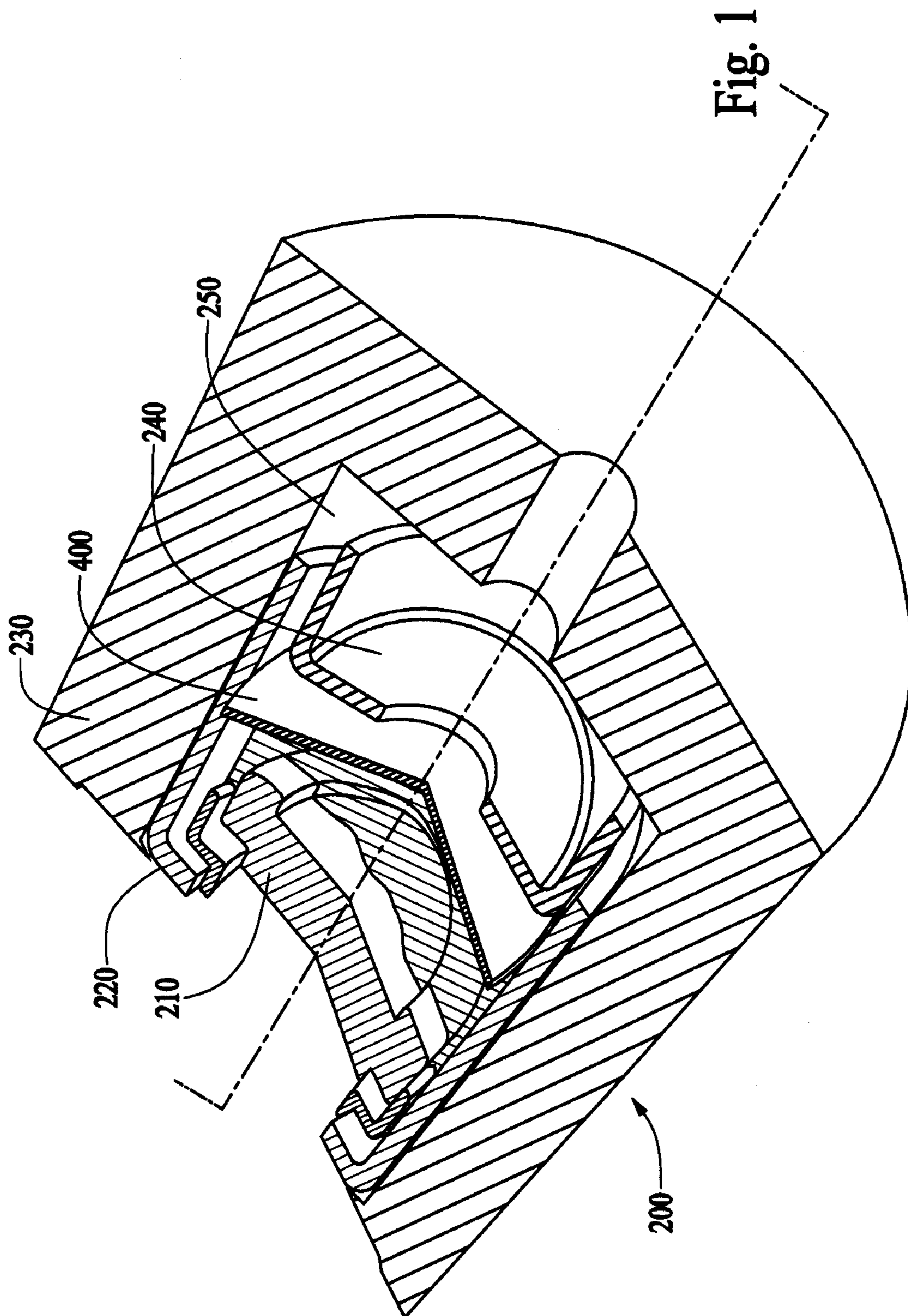

Fig. 1

Figure 2

**LEAD-FREE NANOSCALE
METAL/OXIDIZER COMPOSITE FOR
ELECTRIC PRIMERS**

[0001] The invention described herein may be manufactured and used by or for the government of the United States of America for governmental purposes without the payment of any royalties thereon or therefor.

FIELD OF THE INVENTION

[0002] The present invention relates to lead-free percussion and electric primer compositions, and more particularly, nanoscale primer composition exhibiting reduced ignition delay in applications requiring high firing rates.

BACKGROUND OF THE INVENTION

[0003] Conventional primers for small and medium caliber ammunition historically have been based on lead azide, lead styphnate, mercury fulminate, and barium nitrate. These primer compositions also require expensive handling procedures during both production and disposal. Several tons of these toxic materials and heavy metals are used annually by U.S. commercial suppliers in the production of percussion primer compositions. The detrimental health effects of lead exposure in humans have been extensively documented. The effects include gastrointestinal, cardiovascular, renal, immunological and hematological disorders, and death.

[0004] Environmental concerns about the hazards of lead exposure in the manufacturing process and during firing of small caliber ammunition in closed firing ranges have prompted ammunition manufacturers to develop lead-free primer composition alternatives primarily based on diazodinitrophenol (DINOL) (3). While the DINOL based lead-free primers are sold for commercial applications, they do not meet more stringent military requirements. Primer compositions used in military applications must function reliably between -65° F. to 165° F. The functional reliability of DINOL based primers degrade with decreasing temperature. The fact that externally mounted aircraft weapons are routinely subjected to severe cold conditions, makes the low temperature requirement extremely important. Weapon misfire can have dire consequences. While DINOL primer compositions meet the requirements for commercial applications, it currently does not meet military requirements. In military applications the primer compositions are utilized primarily in primer cup assemblies.

[0005] U.S. Pat. No. 5,266,132 issued on Nov. 30, 1993 to Danen, et al., which is assigned to the U.S. Government, teaches energetic nanoscale compositions, which consist of layers of two reactive substances which are aluminum and cupric oxide, wherein the layers are formed by thin fill deposition. In this composition each layer of aluminum is separated from at least one layer of cupric oxide by a buffer layer. The all-up round action times for the nanoscale metal-metal oxide formulations are much too long (50-500 milliseconds), military requirements for DOD application is less than 4 milliseconds.

[0006] U.S. Pat. No. 5,717,159 issued on Feb. 10, 1998 to Dixon, et al., also assigned to the U.S. Government, teaches the use of nanoscale composites for percussion primer application. The U.S. Department of the Army developed and tested these MIC primers but found that the ignition delay was

greater than 50 milliseconds in comparison to less than 4 milliseconds for conventional lead-based primers. These MIC primer ignition delay times were not suitable for many military applications requiring high firing rates.

[0007] There exists a need in the art for lead-free based nanoscale primer compositions having reduced ignition delays in applications requiring high firing rates.

SUMMARY OF THE INVENTION

[0008] The present invention relates to a lead-free percussion primer composition comprising a mixture of at least one metal having nanometer-sized particles with at least one oxidizer having nanometer-sized particles producing a metal(s)-oxidizer(s) nanocomposite, wherein the oxidizer(s) is present in an effective amount to substantially oxidize the metal(s), at least one gas generating material (gas generator) mixed with the metal(s)-oxidizer(s) nanocomposite producing a metal (s)-oxidizer(s)-gas generator(s) composition, wherein the gas generating material comprises Bis-aminotetrazolyl-tetrazine (BTATz), and at least one binder, wherein the metal(s)-oxidizer(s)-gas generating composition is coated with said binder.

[0009] In another embodiment, the lead-free electric primer composition comprises a mixture of at least one metal having nanometer-sized particles with at least one oxidizer having nanometer-sized particles producing a metal(s)-oxidizer(s) nanocomposite, wherein the oxidizer(s) is present in an effective amount to substantially oxidize the metal(s), at least one gas generating material (gas generator) mixed with the metal(s)-oxidizer(s) nanocomposite producing a metal (s)-oxidizer(s)-gas generator(s) composition, wherein the gas generating material comprises Bis-aminotetrazolyl-tetrazine (BTATz), at least one binder, said metal(s)-oxidizer(s)-gas generating composition is coated with the binder, and at least one conductive material. The conductive material must be added after the binder coating for electric primers.

[0010] It is to be understood that the foregoing general description and the following detailed description are exemplary and explanatory only and are not to be viewed as being restrictive of the present invention, as claimed. Further advantages of this invention will be apparent after a review of the following detailed description of the disclosed embodiments which are illustrated schematically in the accompanying drawings and in the appended claims.

BRIEF DESCRIPTION OF THE DRAWINGS

[0011] FIG. 1 is a cross sectional view of a cartridge case showing the position of the primer composition according to the present invention.

[0012] FIG. 1A is an exploded view of the electric primer cup assembly of the cartridge case shown in FIG. 1, wherein the exploded view illustrates the position of the primer composition according to the present invention.

[0013] FIG. 2 is an alternative perspective view showing a cross section of the electric primer cup assembly shown in FIG. 1, illustrating the position of the primer cup assembly according to the present invention.

DETAILED DESCRIPTION OF THE INVENTION

[0014] The present invention relates to a lead-free percussion primer composition comprising a mixture of at least one metal having nanometer-sized particles with at least one oxidizer having nanometer-sized particles producing a metal(s)-

oxidizer(s) nanocomposite, wherein the oxidizer(s) is present in an effective amount to substantially oxidize the metal(s), at least one gas generating material (gas generator) mixed with the metal(s)-oxidizer(s) nanocomposite producing a metal (s)-oxidizer(s)-gas generator(s) composition, wherein the gas generating material comprises bis-aminotetrazolyl-tetrazine (BTATz), and at least one binder, wherein the metal(s)-oxidizer(s)-gas generating composition is coated with the binder. In another embodiment of the lead-free percussion primer composition, the composition further comprises at least one conductive material.

[0015] In another embodiment, the lead-free electric primer composition **300** comprises, a mixture of at least one metal having nanometer-sized particles with at least one oxidizer having nanometer-sized particles producing a metal(s)-oxidizer(s) nanocomposite, wherein the oxidizer(s) is present in an effective amount to substantially oxidize the metal(s), at least one gas generating material (gas generator) mixed with the metal(s)-oxidizer(s) nanocomposite producing a metal (s)-oxidizer(s)-gas generator(s) composition, wherein the gas generating material comprises bis-aminotetrazolyl-tetrazine (BTATz), at least one binder, the metal(s)-oxidizer(s)-gas generating composition is coated with the binder, and at least one conductive material. The conductive material must be added after the binder coating for electric primers. In another embodiment, the conductive material(s) are uniformly coating the metal(s)-oxidizer(s)-gas generating composition.

[0016] The following description includes both lead-free percussion and electric primer compositions of the present invention. The metal(s) in embodiments of the present invention are in the form of a powder, which includes at least one of aluminum, boron, titanium, zirconium, magnesium, hafnium, and any combination thereof. The metals include particle sizes of up to about 100 nanometers. In other embodiments, the metal(s) in the form of a powder the particle size are in the range of about 20 nm to about 80 nm or about 20 nm to about 60 nm.

[0017] The oxidizer(s) includes metal oxidizer(s) includes at least one of Molybdenum Trioxides (MoO_3), Copper Oxides (CuO), Tungsten Oxides (WO_3), MoO_2 , Molybdenum Oxides (MoO_2), and any combination thereof. When the oxidizer(s) are metal molybdate(s), the oxidizer(s) include M-MoO_4 ($\text{M}=\text{Ag}_2, \text{Sr}, \text{Ca}, (\text{NH}_4)_2$). When the oxidizer(s) are metal nitrate(s), the oxidizer(s) include $\text{M}-(\text{NO}_3)_x$ ($\text{M}=\text{Li}, \text{Na}, \text{K}, \text{Sr}, \text{Ca}$). When the oxidizer(s) are metal perchlorate(s), the oxidizers include $\text{M}-(\text{ClO}_4)_x$ ($\text{M}=\text{Li}, \text{Na}, \text{K}, \text{Ca}, \text{Sr}$). In other embodiments, the oxidizer(s) are in the form of a powder including molybdenum trioxide. The oxidizer(s) are in the form of a powder having a particle size of up to about 100 nanometers. Other particles sizes of oxidizer(s) in the form of a powder include about 20 nm to about 80 nm or about 20 nm to about 60 nm.

[0018] The gas generating material(s) includes at least one of Bis-aminotetrazolyl-tetrazine (BTATz) salts. In other embodiments, the gas generating material(s) includes at least one of Guanidinium Bitetrazole (GBT), Bisguanidinium Azotetrazole (GAZT), Bis-tetrazole (BT), Triamino-guanidinium Nitrate (TAGN), 5-Aminotetrazole (5-AT), and any combination thereof. In other embodiments, the gas generating materials is nanosized but it is not necessary. In embodiments, the gas generating materials including BTATZ formulations prepared utilized micron sized particles. The primer composition includes about 5 weight % to about 50 weight % of the gas generating material(s). In other embodiments, the

primer compositions include about 20 to about 30 weight % of the gas generating material(s). The gas generating material (s) includes BTATZ being about 25 to about 35 wt % of the primer composition. The gas generating material(s) being high nitrogen compounds with rapid decomposition rates. In embodiments of the present invention, gas generating materials would have a peak pressurization time of less than 100 microseconds and a pressurization rate of at least 200,000 psi/s. The problem is that the pressurization rate is system dependent. Sample size, apparatus volume and sample configuration (loose powder, pellet, pellet densification, . . .) affect the rate and overall pressures observed.

[0019] The binder(s) includes at least one of Kel-F®, Teflon®, Polyethylene Oxide (PEO), Polyethylene Glycol (PEG), Glycidyl Azide Polymer (GAP), Hydroxyl-Terminated Polybutadiene (HTPB), and any combination thereof. The fluoropolymer chemical “polychlorotrifluoroethylene” (PCTFE) is sold under the trademark “Kel-F.” The registrant is M. W. Kellogg Company, a Delaware Corporation, 225 Broadway Jersey City, N.J.. The fluoropolymer resins, films, and fibers “polytetrafluoroethylene (PTFE), perfluoroalkoxy (PFA), and fluorinated ethylene polymer (FEP) is sold under the trademark “Teflon.” The registrant is E. L Du Pont De Nemours, a Delaware Corporation, 1007 Market St. Wilmington, Del. In other embodiments, the binder(s) includes at least one of Kel-F® and Teflon®. The binder(s) in other embodiments include a range of about 2 to about 25 weight % of or about 4 weight % of the primer composition. The binder (s) include a particle size of up to about 100 nanometers. The binder(s) is coated onto the metal/oxidizer/gas generating composition in varying thicknesses or uniformly.

[0020] In other embodiments further comprise conductive additive(s) having a particle size of up to about 100 nanometers. Some of the conductive additive(s) includes at least one of carbon black, conductive polymers, conductive submicron metals including (gold, platinum, palladium, and nickel), calcium silicide, and any combination thereof.

[0021] In the lead-free electric primer composition embodiments, at least one conductive material is included. Conductive material is added after the binder coating. The conductive material(s) includes at least one of having a particle size of up to about 100 nanometers.

[0022] The electric and percussion primers of the present invention are unlike conventional primers that contain primary explosives. The nanoscale metal fuel and oxidizer are ignited either by impact (percussion primer) or by electrical ohmic heating (electric primer). The rapid exothermic reaction between the metal fuel and oxidizer initiates rapid decomposition of the gas generator compound that pushes the hot combustion products into the propellant, igniting the propellant bed. The gas generating material is extremely important for reducing ignition delay times from 50 to less than 4 milliseconds.

[0023] In embodiments of the percussion and electric primer compositions, the Bis-aminotetrazolyl-tetrazine (BTATZ) and Kel-F® are mixed with the nanoscale aluminum and molybdenum trioxide. In embodiments of the percussion primer compositions, the composition comprises of about 31 weight % metal (aluminum), about 37 weight % oxidizer (molybdenum trioxide), about 30 weight % gas generating material (BTATZ), and about 2 weight % binder (Kel-F®). In other embodiments of the electric primer compositions, the composition comprises of about 30 weight % metal (aluminum), about 36 weight % oxidizer (molybdenum tri-

oxide), about 30 weight % gas generating material (BTATZ), about 2 weight % binder (Kel-F®), and about 2 weight % additive (carbon black). It was found that about 2 weight % of binder showed improved pressed pellet integrity and improved ignition reliability. In addition, about 2 weight % of carbon showed reliable electric ignition and about 30 weight % of BTATZ showed reduced all-up round action times.

[0024] Carbon black is added for the electric primer application. Where the primer composition according to the present invention is comprised of a nanoscale metal powder, a nanoscale metal oxidizer, a gas generator material, a binder for percussion primer, and conductive material is added for electric primer.

Experimental Results

[0025] The following preparation was performed in processing the primer compositions of the present invention. Others have found that heat-treated MoO₃ and ultrasonic mixing of the primer composition causes minimal aging. A nanoscale Al/MoO₃ composite composed of 45 weight % Al (52.8 nm, 73.8% Active Al) and 55 weight % MoO₃ was purchased from Technanogy, NSWCIH. The MoO₃ in the Al/MoO₃ composite was acquired from Climax® and was lightly ground using a mortar and pestle and sieved through a 270 mesh sieve. Bis-aminotetrazolyl-tetrazine (BTATZ) prepared and purified at China Lake was lightly ground with a mortar and pestle and sieved through a 270-mesh sieve. Kel-F® also known as polychlorotrifluoroethylene (PCTFE) is a fluorochemical product and was used and received from the Kellogg® Company. Carbon was obtained from Chevron-Phillip® and sieved through a 270 mesh sieve prior to use.

[0026] Nanoscale material performance degrades with time. AlO passivation thickness dramatically affects aging in air. Al with 1.7 nm oxide layer exhibits a dramatic loss in active Al over time and Al with 2.7 nm oxide layer loses some active Al initially but stabilizes after 2 weeks. Some MoO₃ changes color, loses surface area, absorbs water and undergoes a phase change over time. The MoO₃ hydrate catalyzes the hydrolysis of nanoscale aluminum powders. It was found that heat treatment to the a phase reduces aging effects. This data showed that mixing conditions affect material performance and aging. The mixing techniques utilized for Al/MoO₃ composites in the present invention showed no aging after >6 months.

[0027] In the first example, 0.712 g of the Al/MoO₃ composite and 0.320 g of BTATZ were transferred into a vial and mixed with a shaker for about 2 minutes. Approximately 0.012 g of Kel-F® was added and dissolved in 10 ml of CH₂Cl₂ to the mixture. The solvent (CH₂Cl₂) was evaporated off the slurry mixture by blowing nitrogen gas over its surface for about 2 hours. The product was dried under vacuum for about 2 hours. Carbon (0.021 g) was added to the Al/MoO₃/Kel-F® solid and mixed with a shaker (Electric Primer).

[0028] In the second example, 0.846 g of the Al/MoO₃ composite and 0.220 g of BTATZ was transferred into a vial and mixed with a shaker for about 2 minutes. Approximately 0.027 g of Kel-F® was added and dissolved in 10 ml of CH₂Cl₂ to the mixture. The solvent was evaporated off the slurry mixture by blowing nitrogen gas over its surface for about 2 hours. The product was dried under vacuum for 2 hours. Carbon (0.024 g) was added to the Al/MoO₃/Kel-F® solid and mixed with a shaker (Electric Primer).

[0029] In the third example, 1.038 g of the Al/MoO₃ composite and 0.125 g of BTATZ was transferred into a vial and

mixed with a shaker for about 2 minutes. Approximately, 0.026 g of Kel-F® was added and dissolved in 11 ml of CH₂Cl₂ to the mixture. The solvent was evaporated off the slurry mixture by blowing nitrogen gas over its surface for about 2 hours. The product was dried under vacuum for 12 hours. Carbon (0.021 g) was added to the Al/MoO₃/Kel-F® solid and mixed with a shaker (Electric Primer).

[0030] In the fourth example, 0.733 g of the Al/MoO₃ composite and 0.314 g were mixed in a vial using a shaker for about 2 minutes. Approximately 0.021 g of Kel-F® was added and dissolved in 5 ml of CH₂Cl₂ to the mixture. The solvent was evaporated off the slurry mixture by blowing nitrogen gas over its surface for about 2 hours. The product was dried under vacuum for 12 hours (Percussion Primer).

[0031] In the fifth example, 0.082 g of Kel-F® was dissolved in 35 ml of CH₂Cl₂. Approximately, 2.644 g of the Al/MoO₃ composite was added to the Kel-F®/CH₂Cl₂ solution and stirred for 1 minute using a magnetic stirbar and magnetic stirrer. Approximately 1.202 g of BTATZ was added to the mixtures and mixing continued for 2 minutes. The solvent was evaporated off the slurry mixture by blowing nitrogen gas over its surface for about 2 hours. The product was dried under vacuum for about 12 hours. Approximately 0.081 g of carbon was added to the dried solid and mixed with a shaker for 2 minutes (Electric Primer).

[0032] In the sixth example, 0.020 g of Polyethylene Glycol (PEG) was added and dissolved in 25 ml of hexane. Approximately 12.5 ml of the PEG solution was added to the 0.712 g of the Al/MoO₃ composite and 12.5 ml to 0.305 g of BTATZ in 2 separate vials. The 2 mixtures were combined and mixed for 2 minutes using a magnetic stir-bar and magnetic stirrer. The solvent was evaporated off the slurry mixture by blowing nitrogen gas over its surface for about 2 hours. The product was dried under vacuum for 12 hours. (Percussion Primer).

[0033] FIGS. 1, 1A and 2 illustrate cross sectional views of an electric primer cup assembly showing the placement of the primer compositions of the present invention. One embodiment of an electric primer cup assembly 100 includes an insulator 120/210, button 110, cup 130/220, paper 140/240, support cup 250, cartridge case 230 and energetic material 300/400. In an embodiment of the present invention, the brass button 110 and the brass primer cup 130 serve as electrodes with an insulator layer 120 between them. Energetic material 300 is consolidated into the primer cup using a paper separator 140 and a press. The paper is used to prevent energetic material sticking to the rod used consolidate the energetic material. A support cup is inserted to hold the energetic material and paper in the desired configuration. The primer cup assembly 100 is then inserted into the loaded cartridge case 230. To initiate firing of a round, a potential is applied through the electrodes (button and cup) that rapidly heat the energetic material via ohmic heating. The rapid rise in temperature ignites the primer energetic material. The hot reaction products are transported into and ignite the propellant bed. The hot gases formed from the propellant propel the projectile out of the casing.

[0034] Major advantages of the present invention include, but are not limited to, use in lead-free percussion and electric primers, meets military required action time of 4 ms, and has application for small, medium, and large caliber ammunition, flash bang grenades (stun-grenades), indoor/outdoor pyrotechnics, flares, mini-thrusters for missile guidance, anti-tamper devices, and additives for explosives and propellants.

[0035] While the invention has been described, disclosed, illustrated and shown in various terms of certain embodiments or modifications which it has presumed in practice, the scope of the invention is not intended to be, nor should it be deemed to be, limited thereby and such other modifications or embodiments as may be suggested by the teachings herein are particularly reserved especially as they fall within the breadth and scope of the claims here appended.

1. A lead-free electric primer composition comprising:
 - a mixture of at least one metal having nanometer-sized particles with at least one oxidizer having nanometer-sized particles producing a metal(s)-oxidizer(s) nanocomposite, wherein said oxidizer(s) is present in an effective amount to substantially oxidize said metal(s);
 - at least one gas generating material (gas generator) mixed with said metal(s)-oxidizer(s) nanocomposite producing a metal(s)-oxidizer(s)-gas generator(s) composition, wherein said gas generating material comprises bis-aminotetrazolytetrazine (BTATz);
 - at least one binder, said metal(s)-oxidizer(s)-gas generating material composition is coated with said binder; and
 - at least one conductive material.
2. The composition according to claim 1, wherein said metal(s) being in the form of a powder which comprises at least one of aluminum, boron, titanium, zirconium, magnesium, hafnium, and any combination thereof.
3. The composition according to claim 1, wherein said metal is a powder having a particle size of up to about 100 nanometers.
4. The composition according to claim 1, wherein said metal is a powder having a particle size of about 20 nm to about 80 nm.
5. The composition according to claim 4, wherein said metal is a powder having a particle size of about 20 nm to about 60 nm.
6. The composition according to claim 1, wherein said oxidizer(s) includes metal oxidizer(s) comprising at least one of Molybdenum Trioxide (MoO_3), Copper Oxide (CuO), Tungsten Oxide (WO_3), Molybdenum Dioxide (MoO_2), and any combination thereof.
- 7-9. (canceled)
10. The composition according to claim 1, wherein said oxidizer(s) being in the form of a powder is molybdenum trioxide.
11. The composition according to claim 1, wherein said oxidizer is a powder having a particle size of up to about 100 nanometers.
12. The composition according to claim 1, wherein said oxidizer is a powder having a particle size of about 20 nm to about 80 nm.
13. The composition according to claim 12, wherein said oxidizer is a powder having a particle size of about 20 nm to about 60 nm.

14. The composition according to claim 1, wherein said gas generating material(s) comprises at least one of bis-aminotetrazolytetrazine (BTATz) salts.

15. (canceled)

16. The composition according to claim 1, wherein said gas generating material comprises about 5 to about 50 weight % of said primer composition.

17. The composition according to claim 16, wherein said gas generating material comprises about 25 to about 35 weight % of said primer composition.

18. The composition according to claim 1, wherein said gas generating material comprises about 20 to about 30 weight % of said primer composition.

19. The composition according to claim 1, wherein said binder(s) comprises at least one of polychlorotrifluoroethylene (PCTFE), Polyethylene Oxide (PEO), Polyethylene Glycol (PEG), Glycidyl Azide Polymer (GAP), Hydroxyl-Terminated Polybutadiene (HTPB), and any combination thereof.

20. The composition according to claim 1, wherein said binder comprises at least one of polychlorotrifluoroethylene (PCTFE).

21. The composition according to claim 1, wherein said primer composition includes about 2 to about 25 weight % of said binder.

22. The composition according to claim 21, wherein said primer composition includes about 4 weight % of said binder.

23. The composition according to claim 1, wherein said binder is a powder having a particle size of up to about 100 nanometers.

24. The composition according to claim 1, wherein said conductive material is a powder having a particle size of up to about 100 nanometers.

25. The composition according to claim 1, further comprising conductive additive having a particle size of up to about 100 nanometers.

26. The composition according to claim 1, wherein said conductive material comprises at least one of carbon black.

27. The composition of claim 1, wherein said at least one metal is a powder, having nanometer-sized particles, including Aluminum.

28. A lead-free electric primer composition comprising: a metal powder, having nanometer-sized particles, including Aluminum;

an oxidizer powder, having nanometer-sized particles, including molybdenum trioxide (MoO_3) in sufficient amount to substantially oxidize said Aluminum;

a gas generating material including bis-aminotetrazolytetrazine (BTATz);

a binder including polychlorotrifluoroethylene (PCTFE); and

a conductive material including carbon black in sufficient amount to render the composition electrically conducting.

* * * * *