

(19) **United States**

(12) **Patent Application Publication**

**Ray et al.**

(10) **Pub. No.: US 2011/0205688 A1**

(43) **Pub. Date: Aug. 25, 2011**

(54) **MULTILAYER CARBON NANOTUBE CAPACITOR**

**Publication Classification**

(75) Inventors: **William Johnstone Ray**, Fountain Hills, AZ (US); **Mark David Lowenthal**, Gilbert, AZ (US); **Neil O. Shotton**, Tempe, AZ (US); **Thomas William Clinton**, Danville, CA (US); **Theodore I. Kamins**, Palo Alto, CA (US); **Vera Nicholaevna Lockett**, Phoenix, AZ (US)

(51) **Int. Cl.**  
*H01G 9/155* (2006.01)  
*B82Y 99/00* (2011.01)

(52) **U.S. Cl.** ..... **361/502; 977/750; 977/752; 977/948**

(73) Assignee: **NTHDEGREE TECHNOLOGIES WORLDWIDE INC.**, Tempe, AZ (US)

(57) **ABSTRACT**

Multilayer carbon nanotube capacitors, and methods and printable compositions for manufacturing multilayer carbon nanotubes (CNTs) are disclosed. A first capacitor embodiment comprises: a first conductor; a plurality of fixed CNTs in an ionic liquid, each fixed CNT comprising a magnetic catalyst nanoparticle coupled to a carbon nanotube and further coupled to the first conductor; and a first plurality of free CNTs dispersed and moveable in the ionic liquid. Another capacitor embodiment comprises: a first conductor; a conductive nanomesh coupled to the first conductor; a first plurality of fixed CNTs in an ionic liquid and further coupled to the conductive nanomesh; and a plurality of free CNTs dispersed and moveable in the ionic liquid. Various methods of printing the CNTs and other structures, and methods of aligning and moving the CNTs using applied electric and magnetic fields, are also disclosed.

(21) Appl. No.: **13/025,137**

(22) Filed: **Feb. 10, 2011**

**Related U.S. Application Data**

(60) Provisional application No. 61/306,162, filed on Feb. 19, 2010.

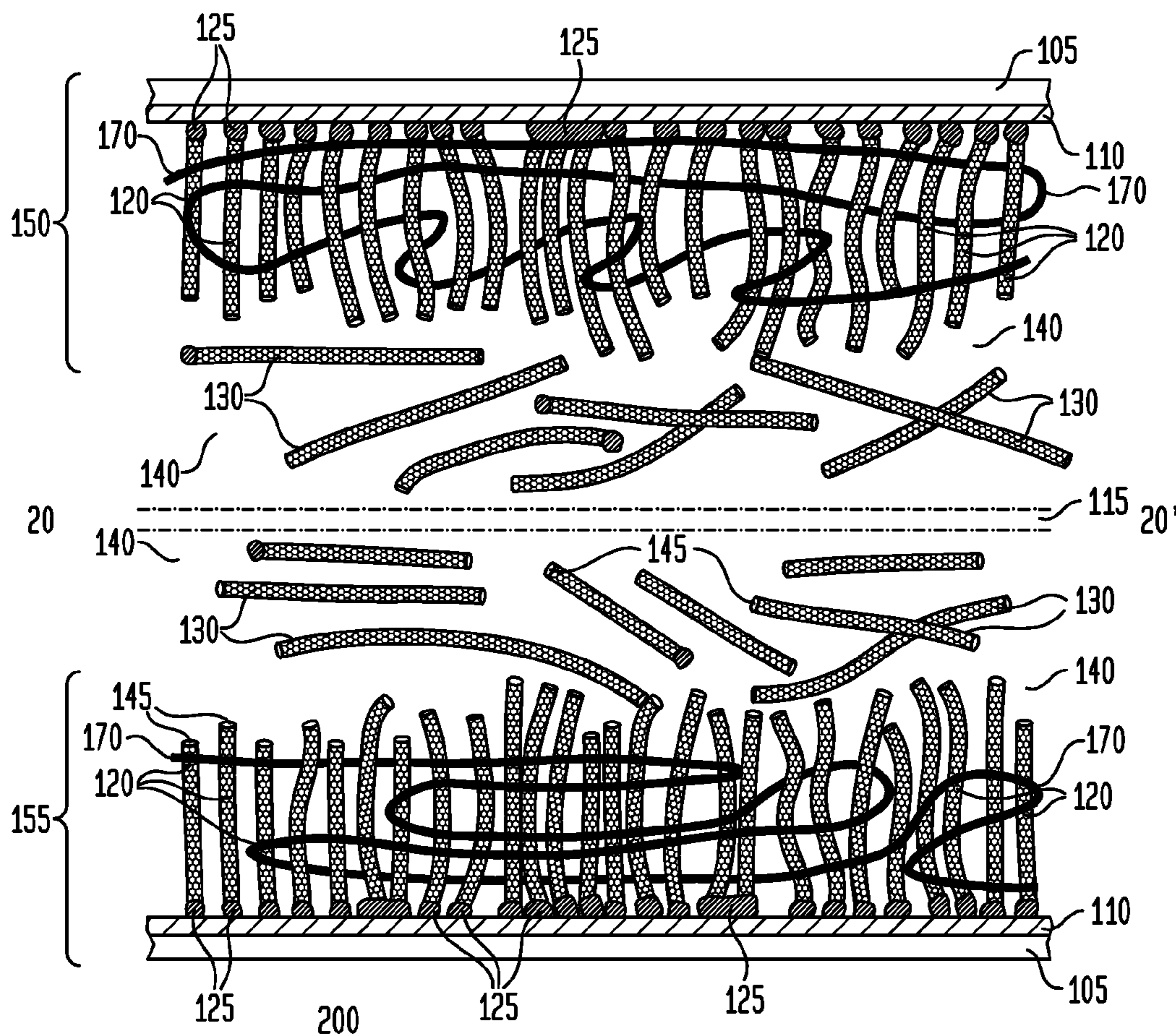

**FIG. 1**

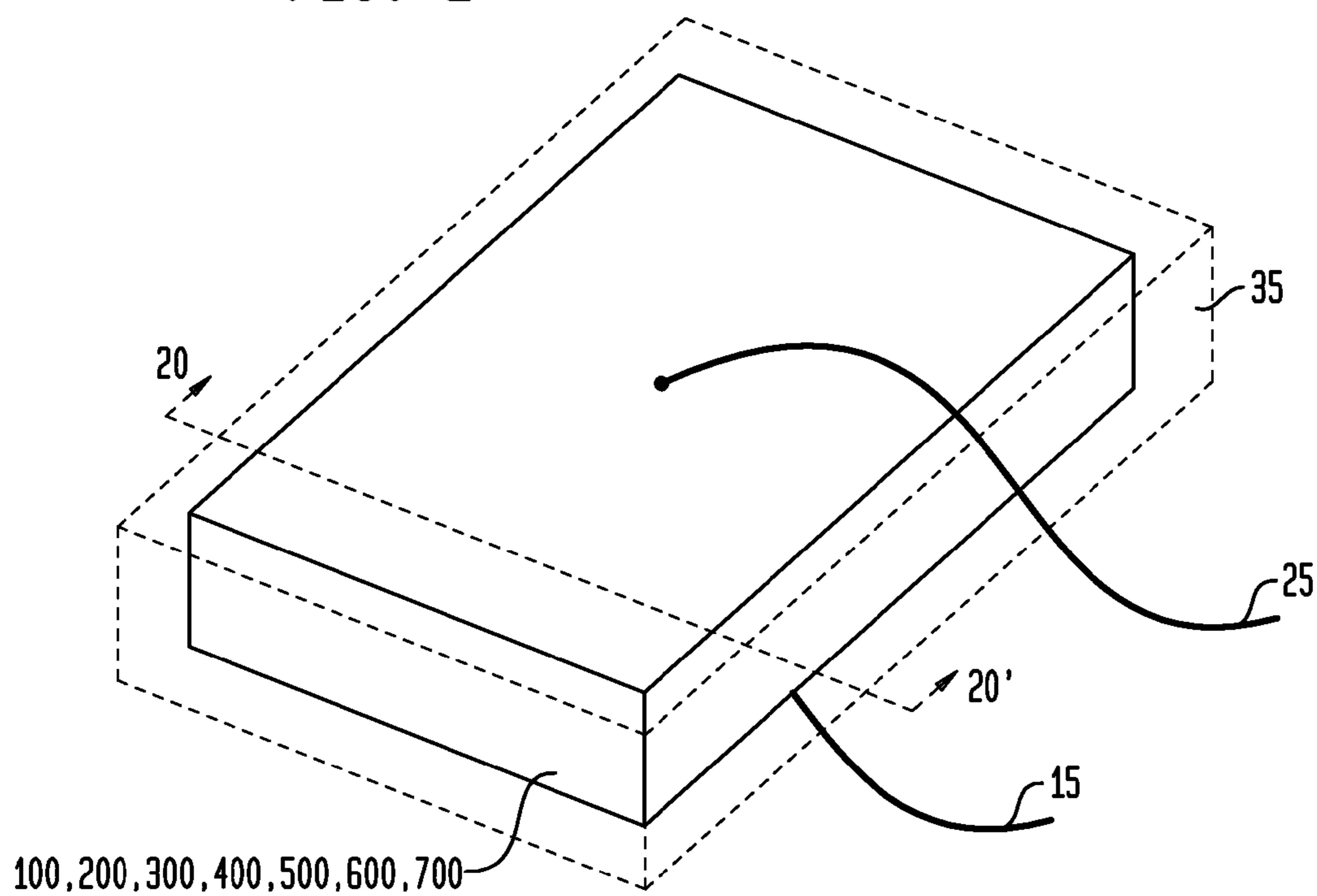
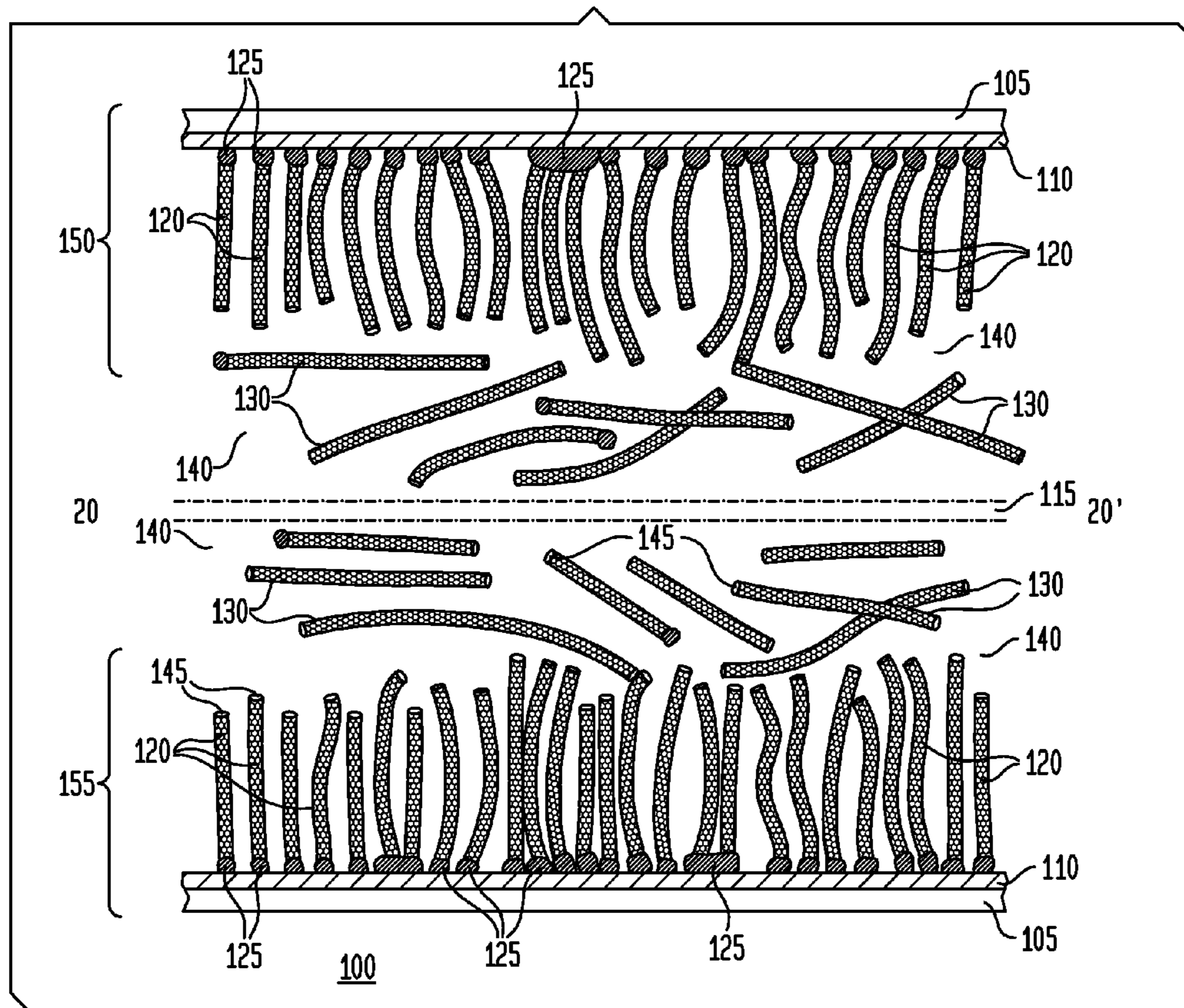

FIG. 2



**FIG. 3**

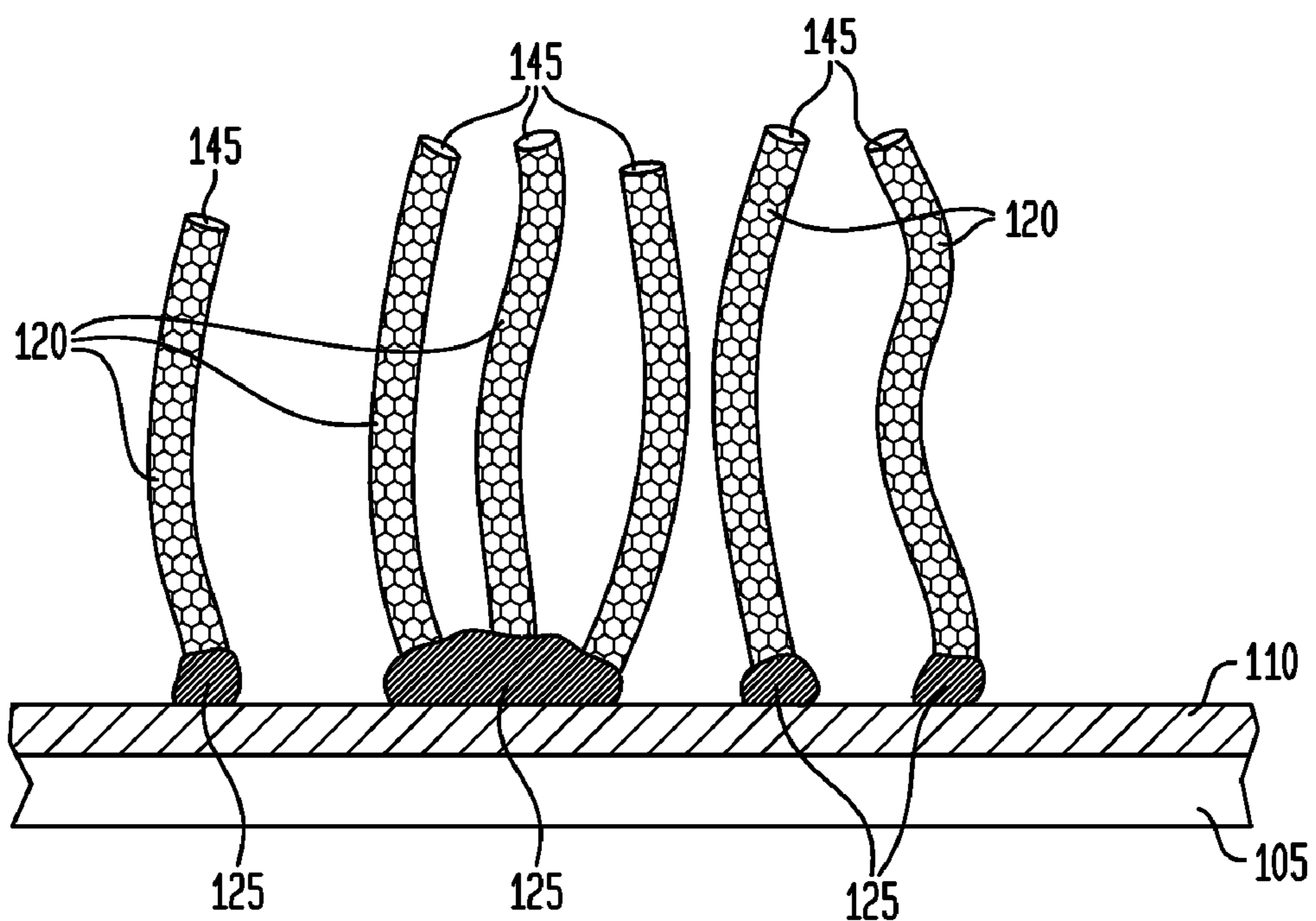

FIG. 4

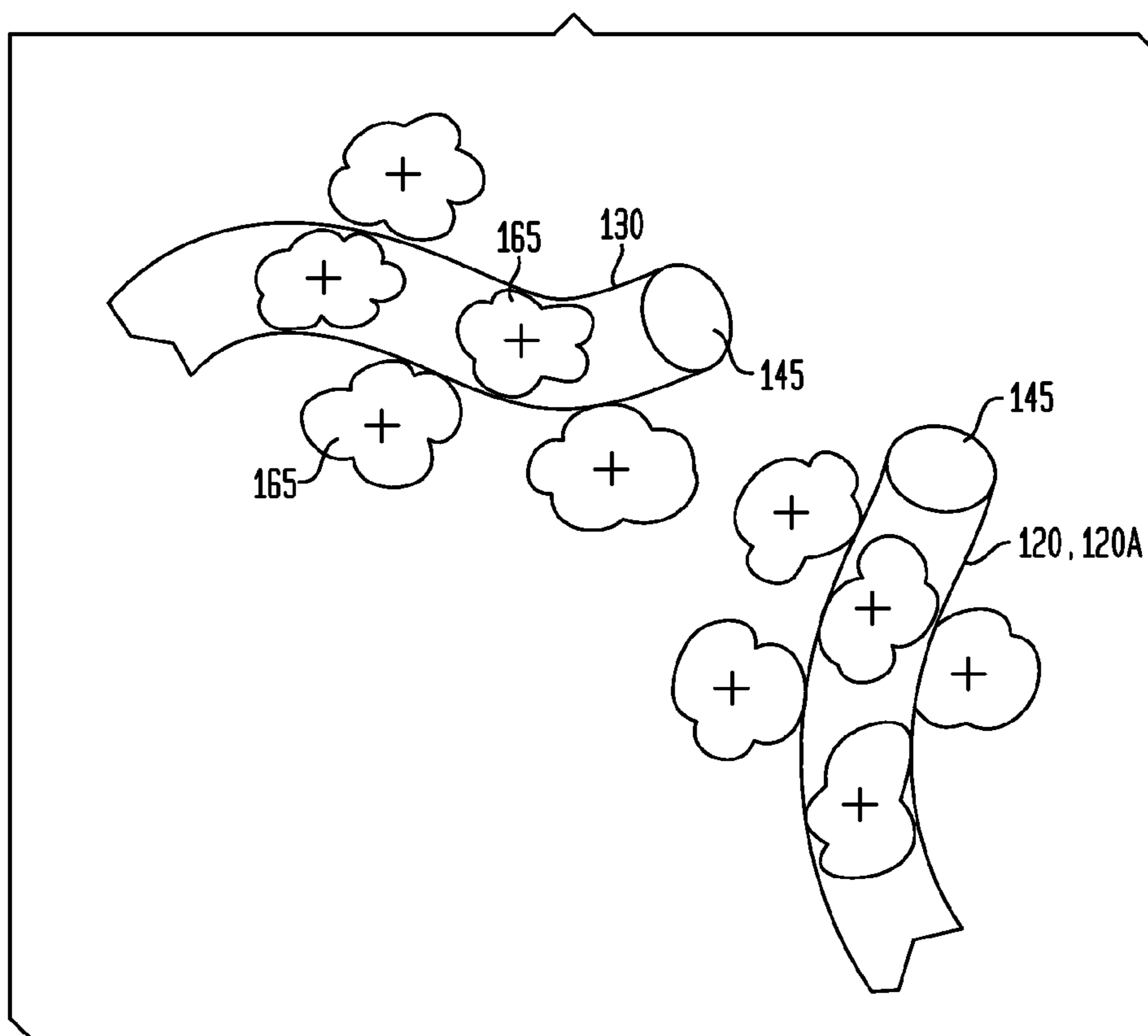

FIG. 5

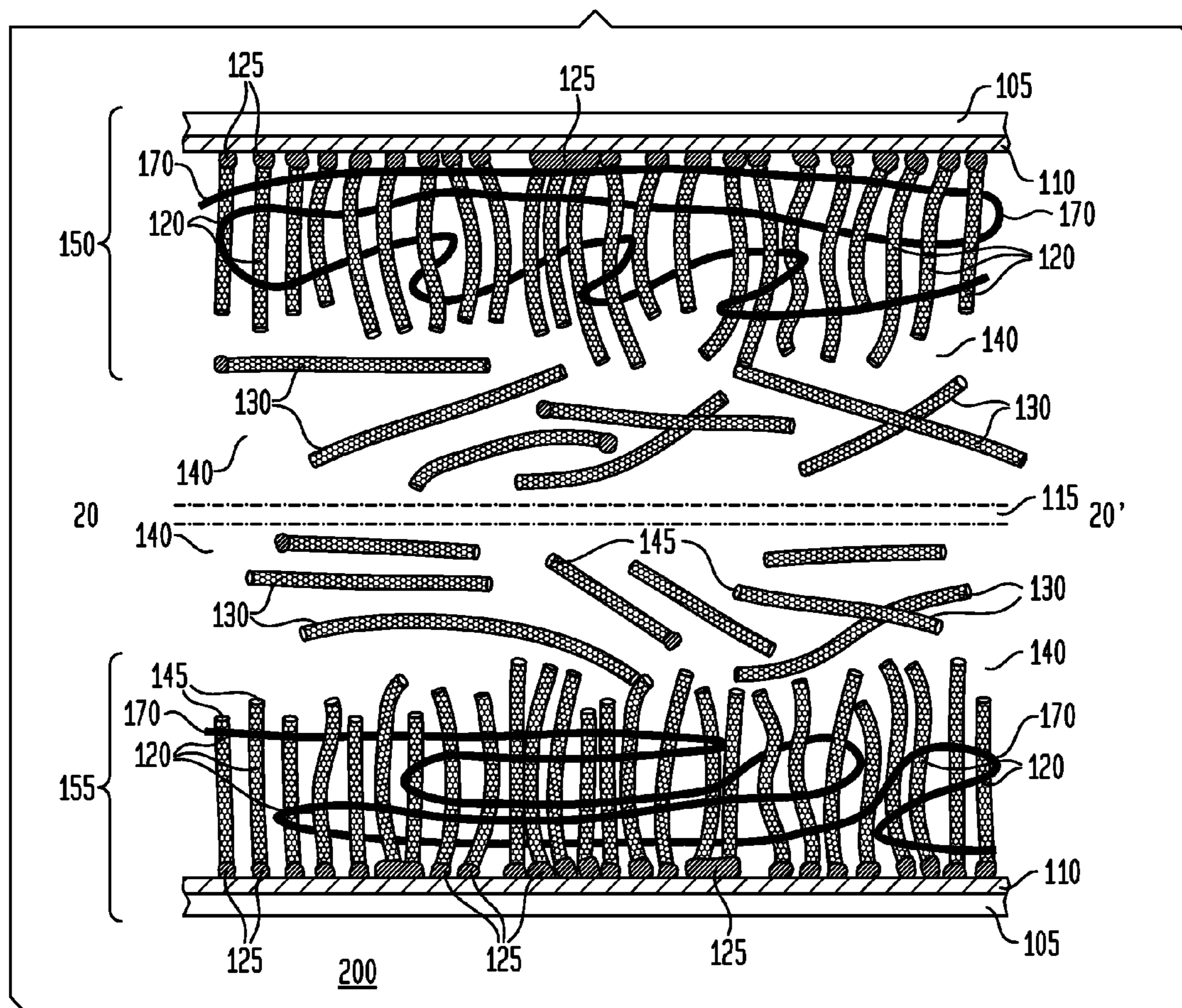

FIG. 6

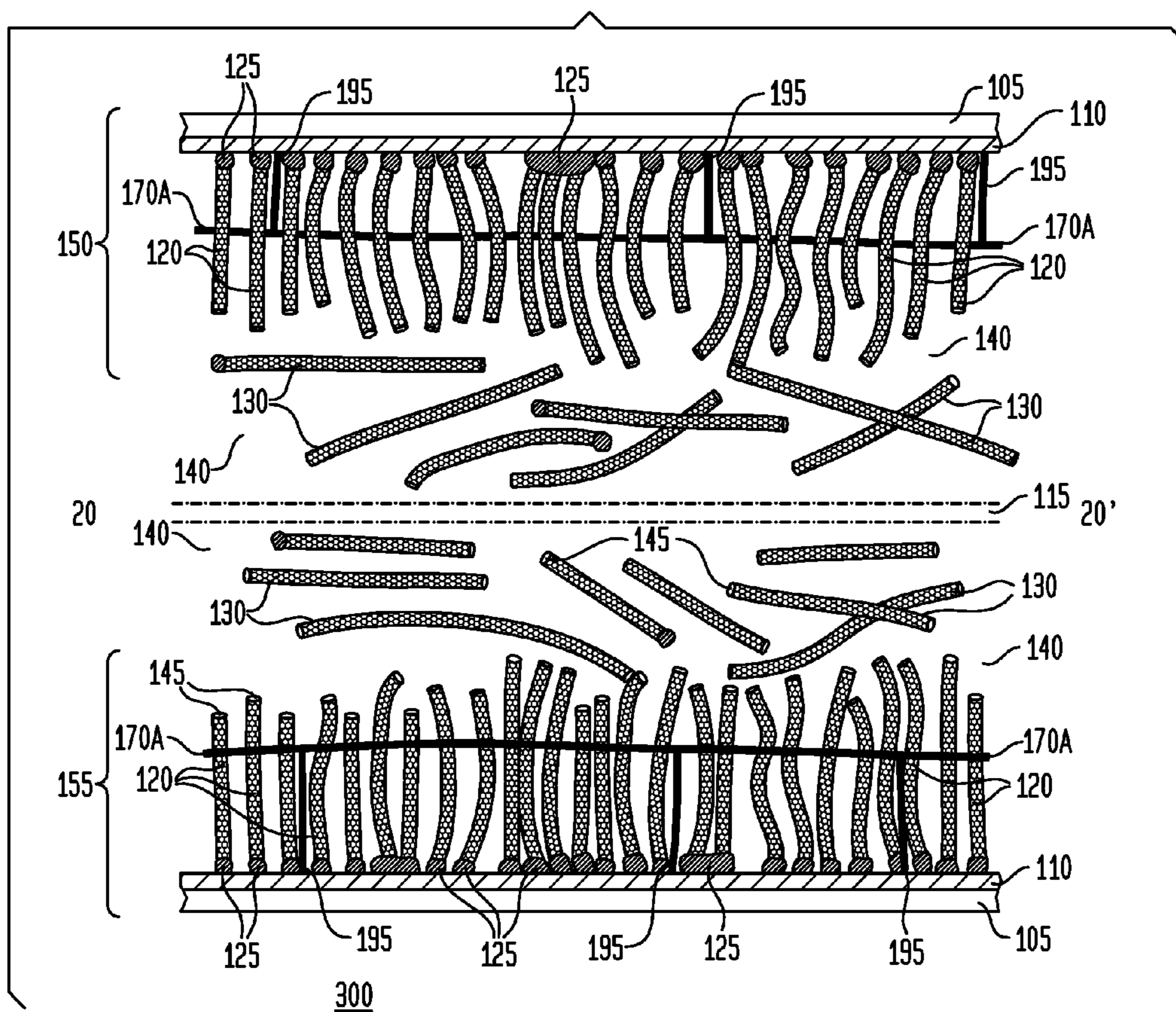

FIG. 7

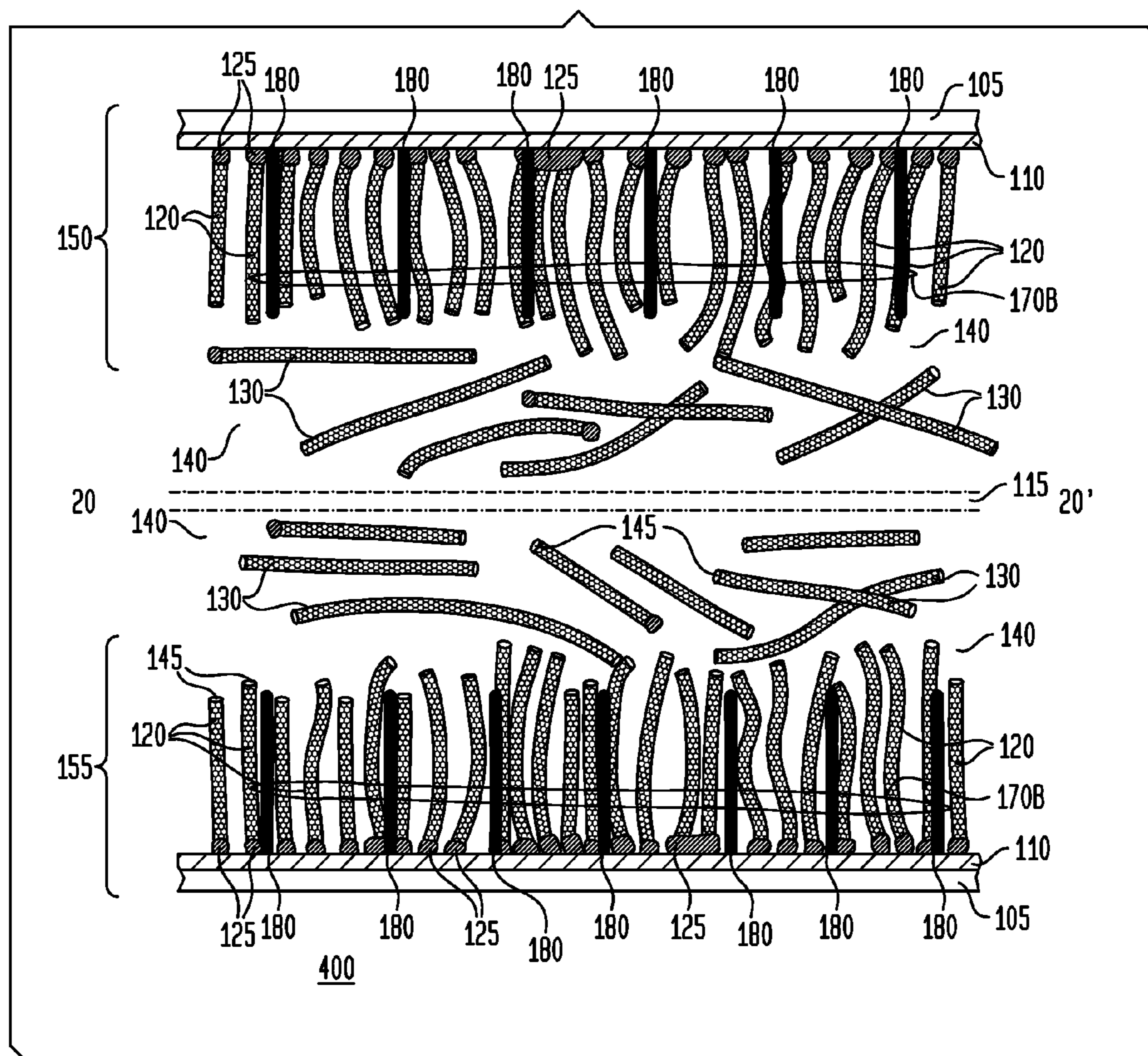



FIG. 8

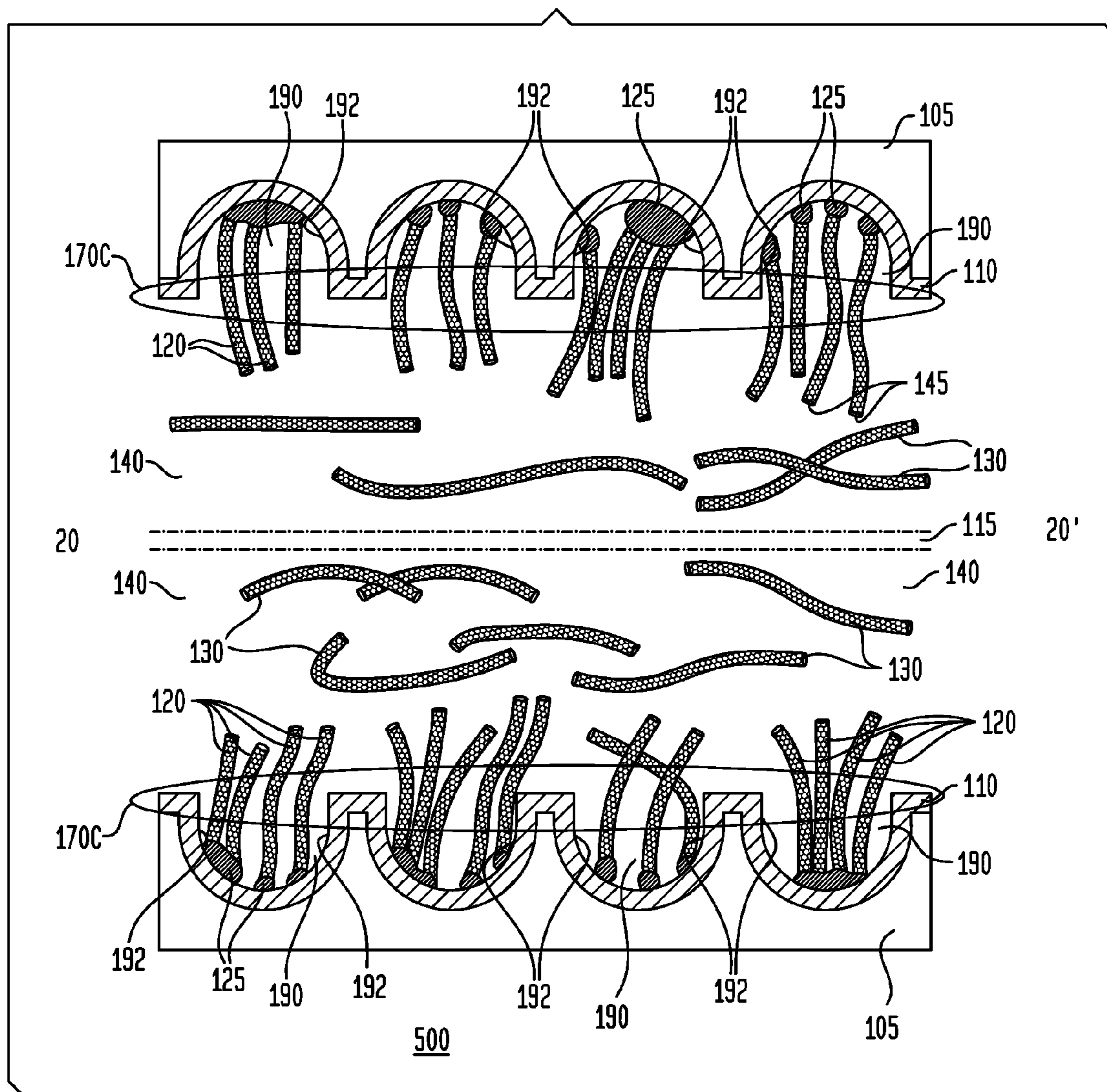

FIG. 9

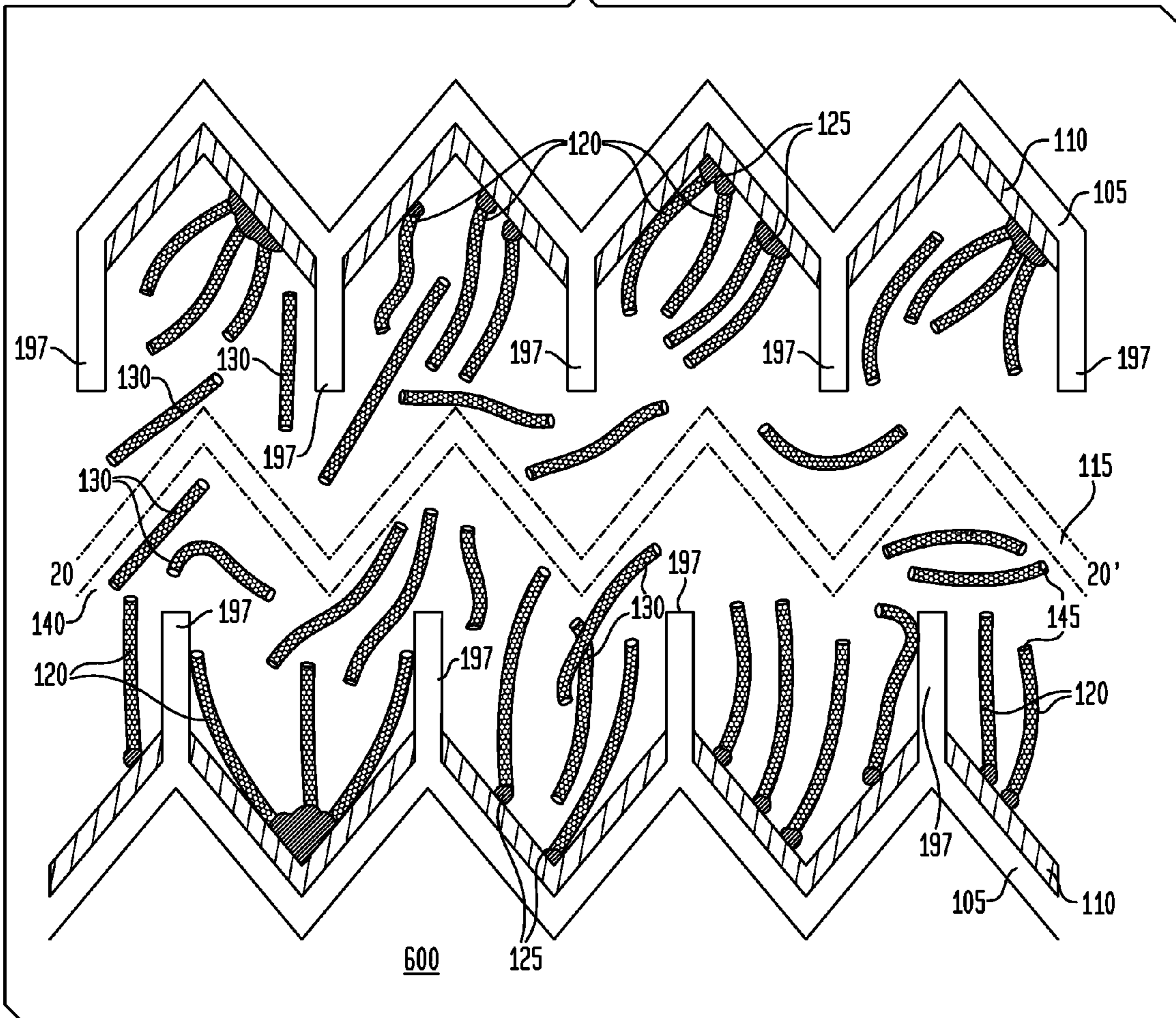
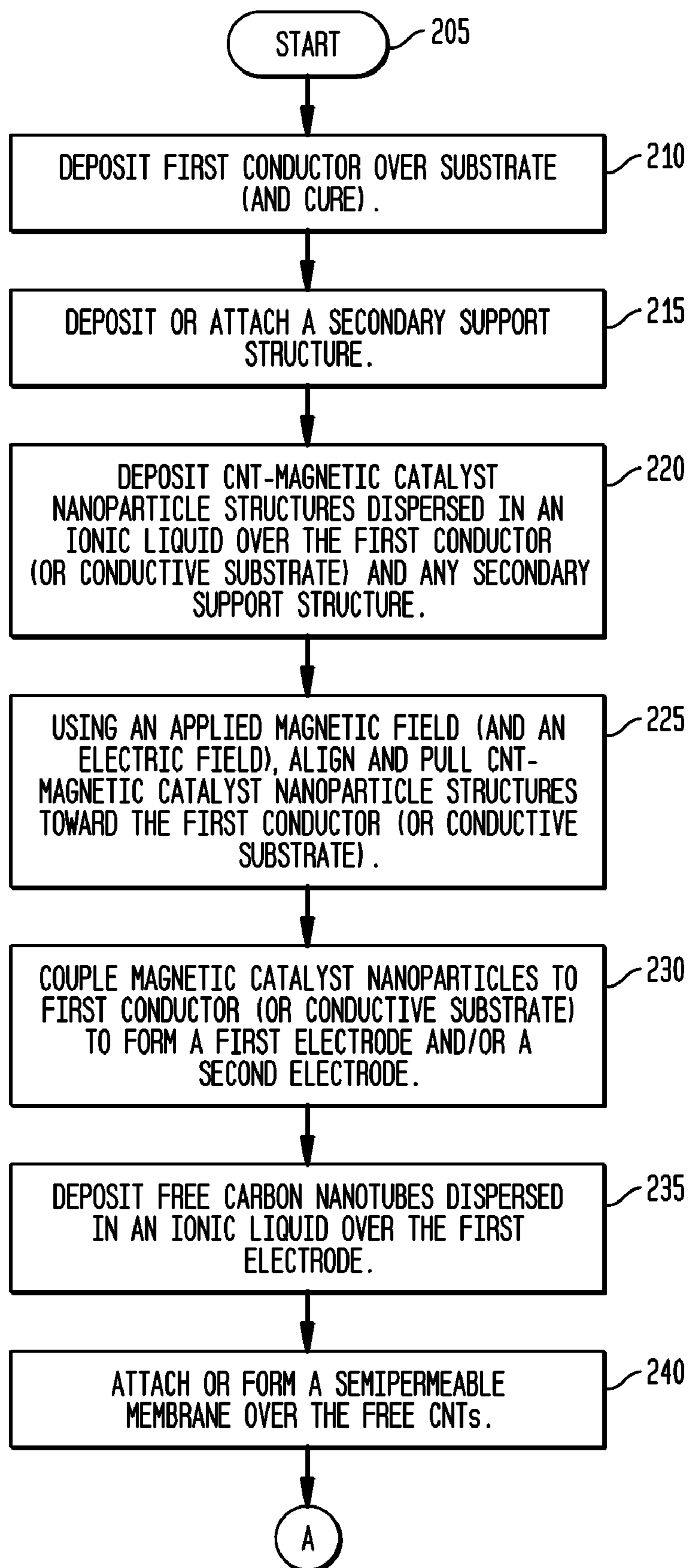

FIG. 10A



**FIG. 10B**

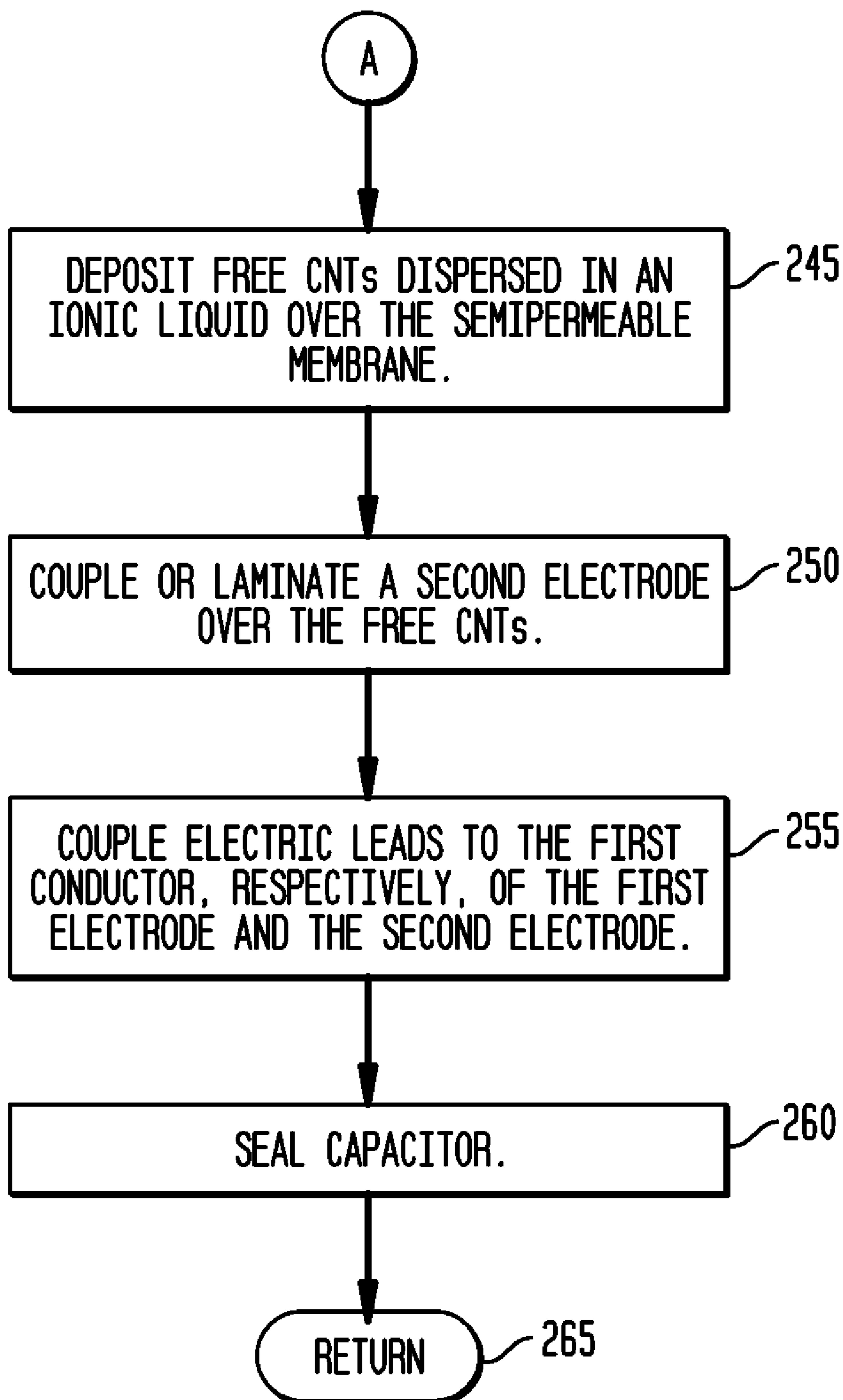

FIG. 11

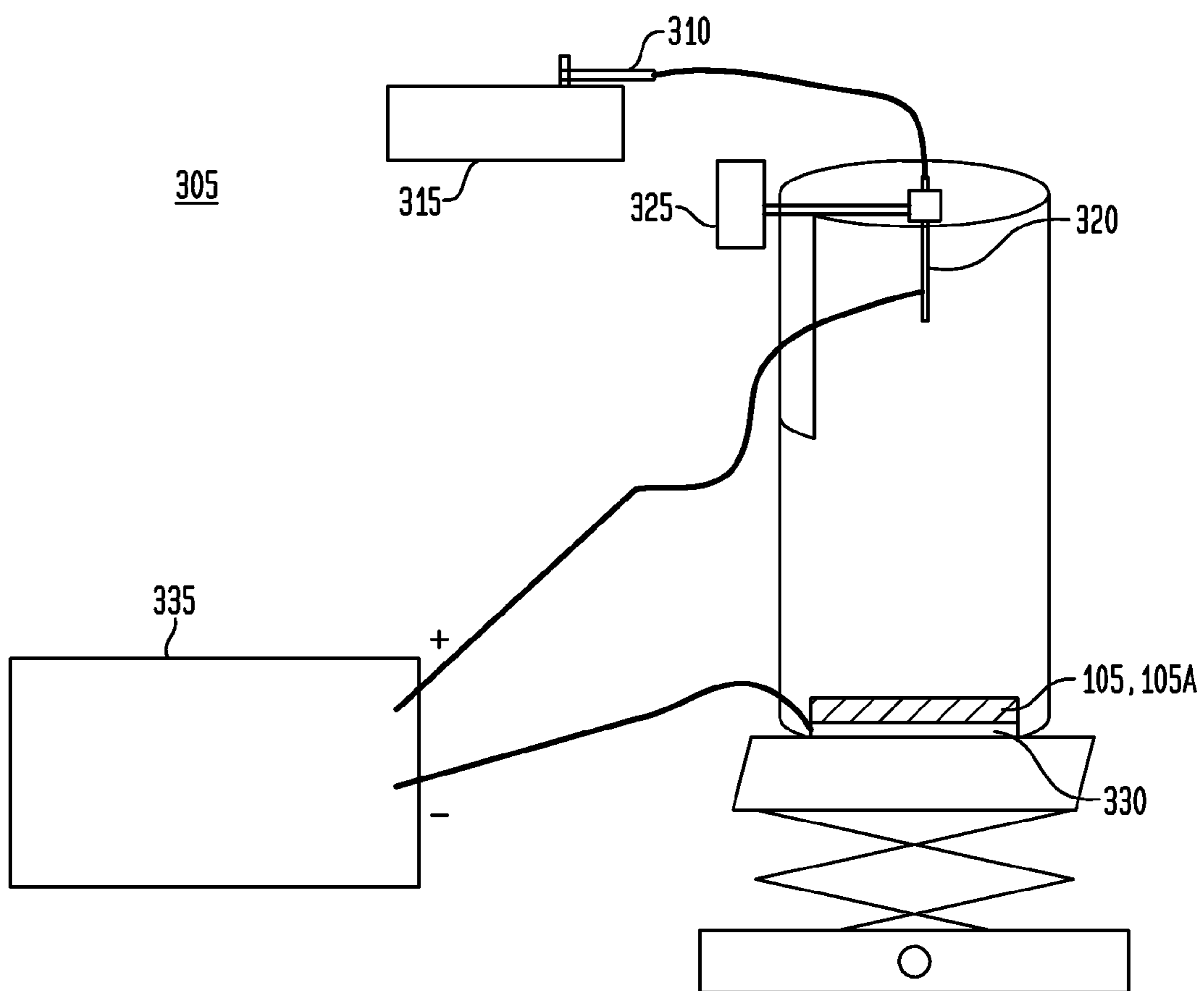

FIG. 12

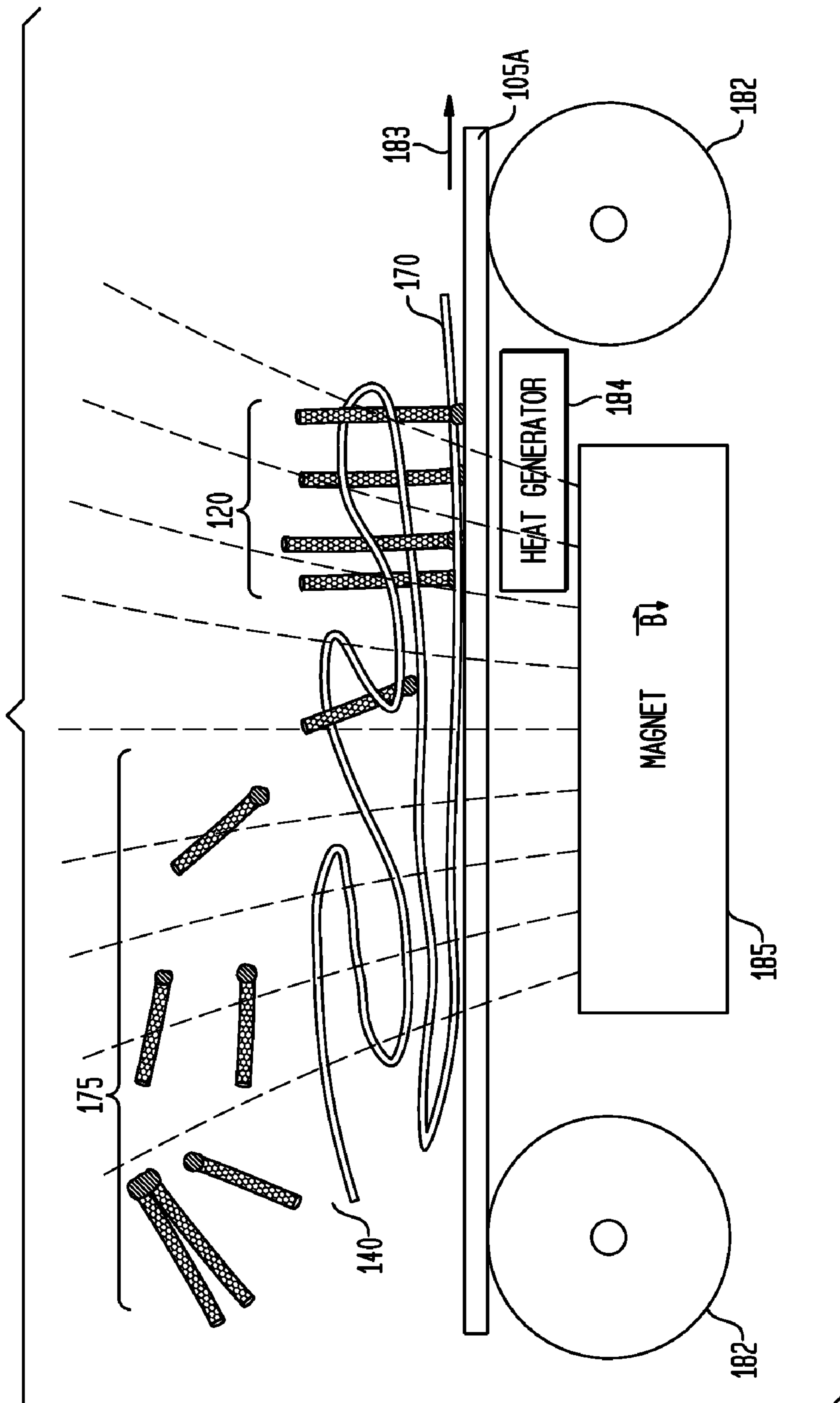

FIG. 13

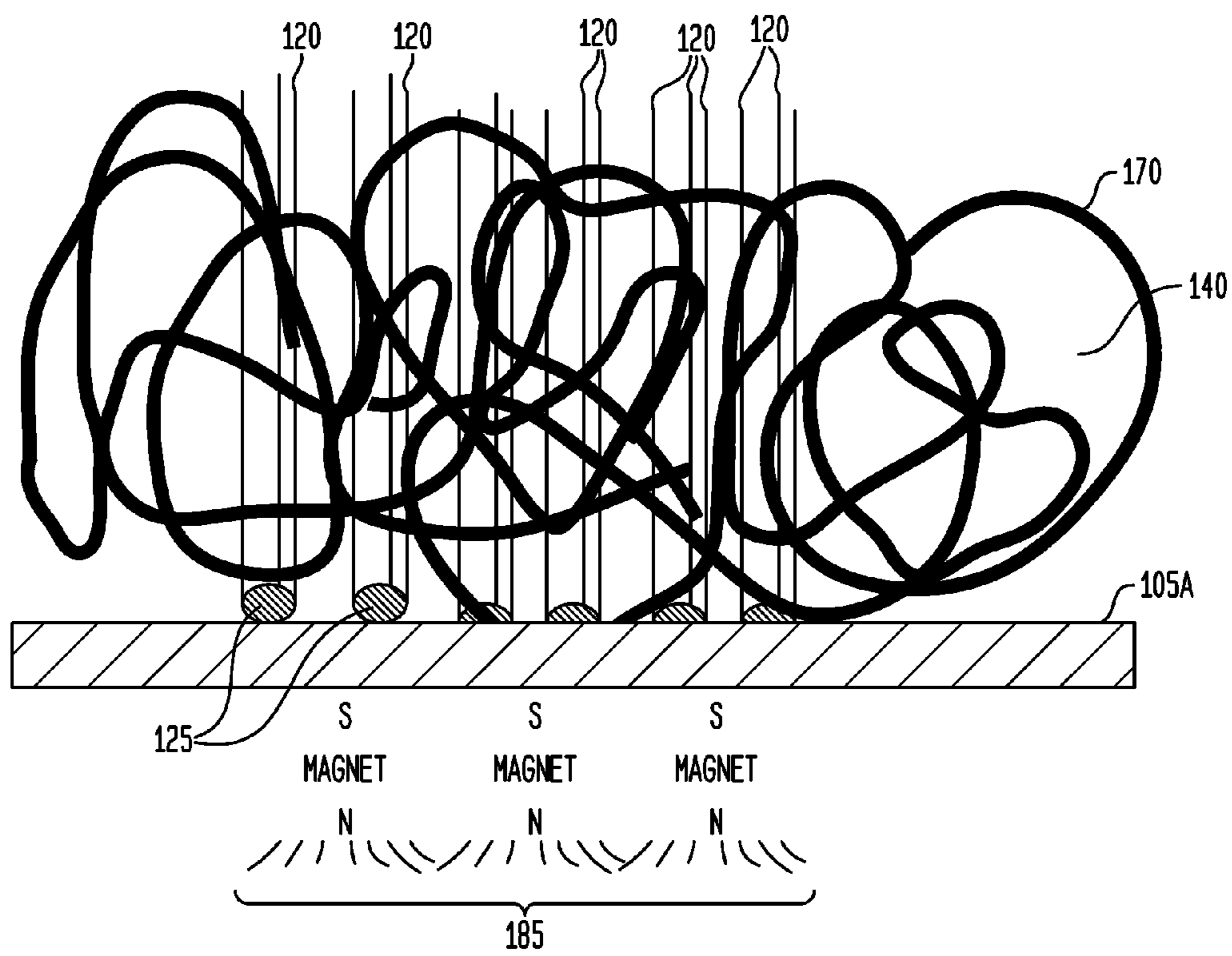

FIG. 14

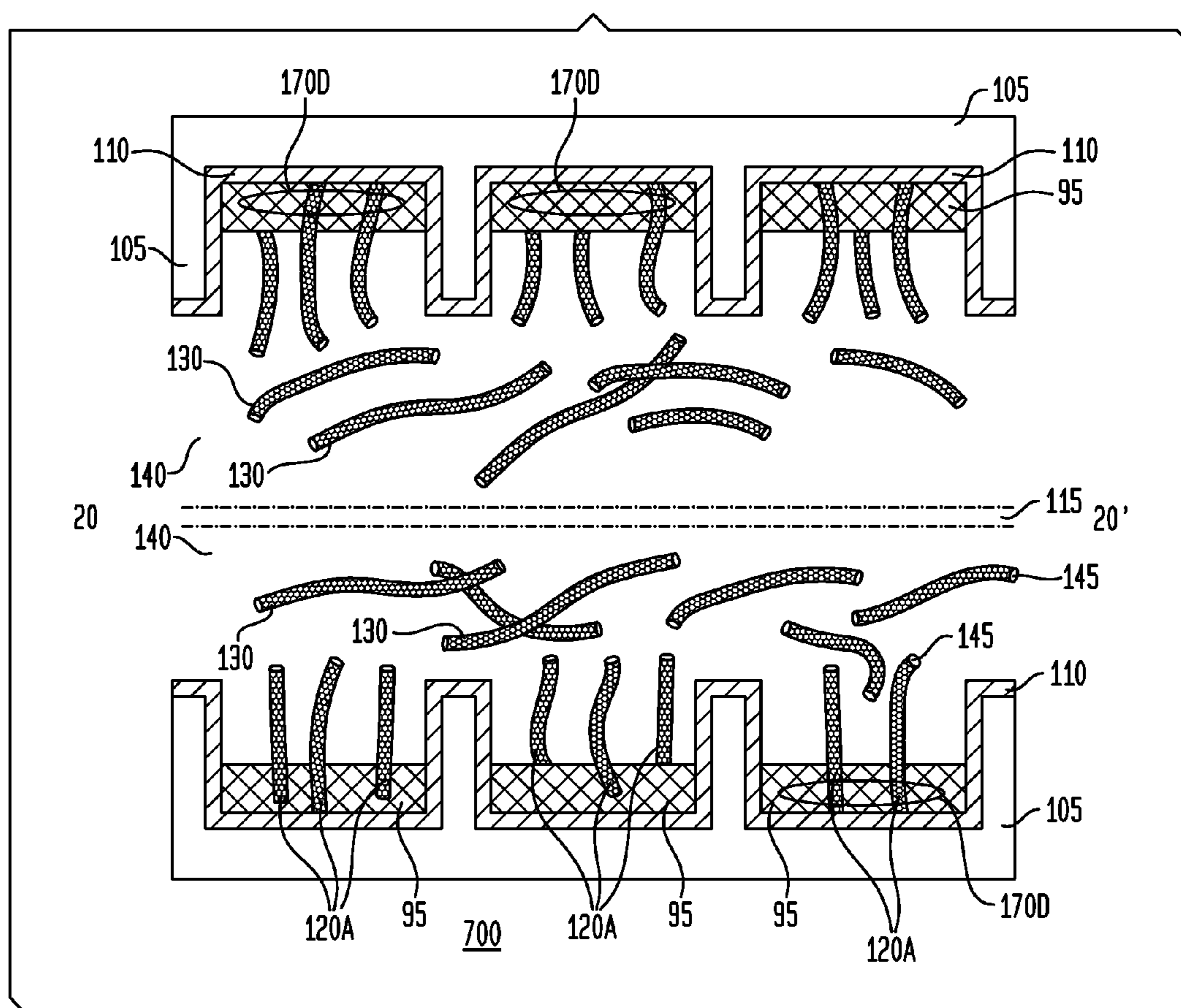
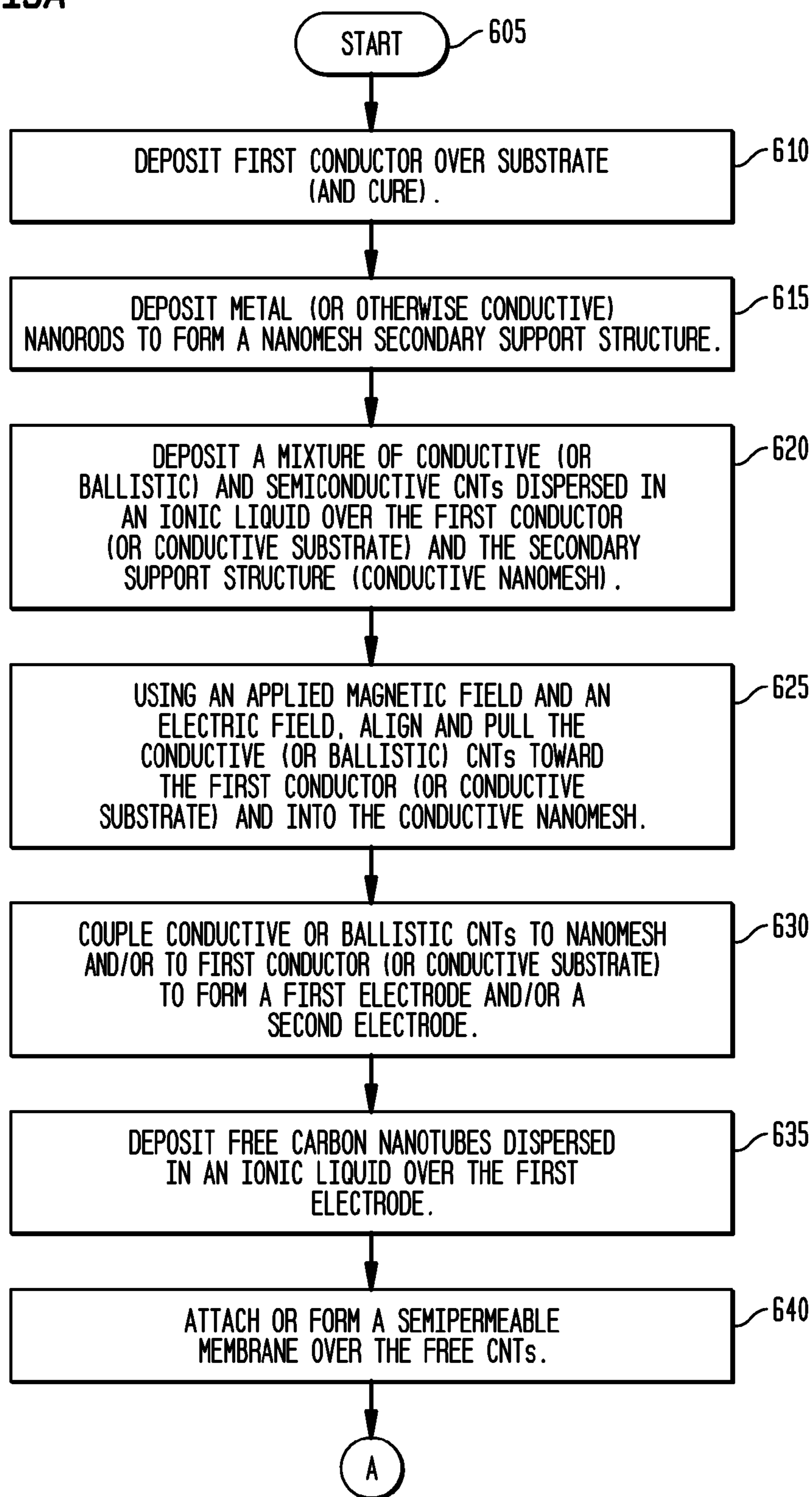



FIG. 15A



**FIG. 15B**

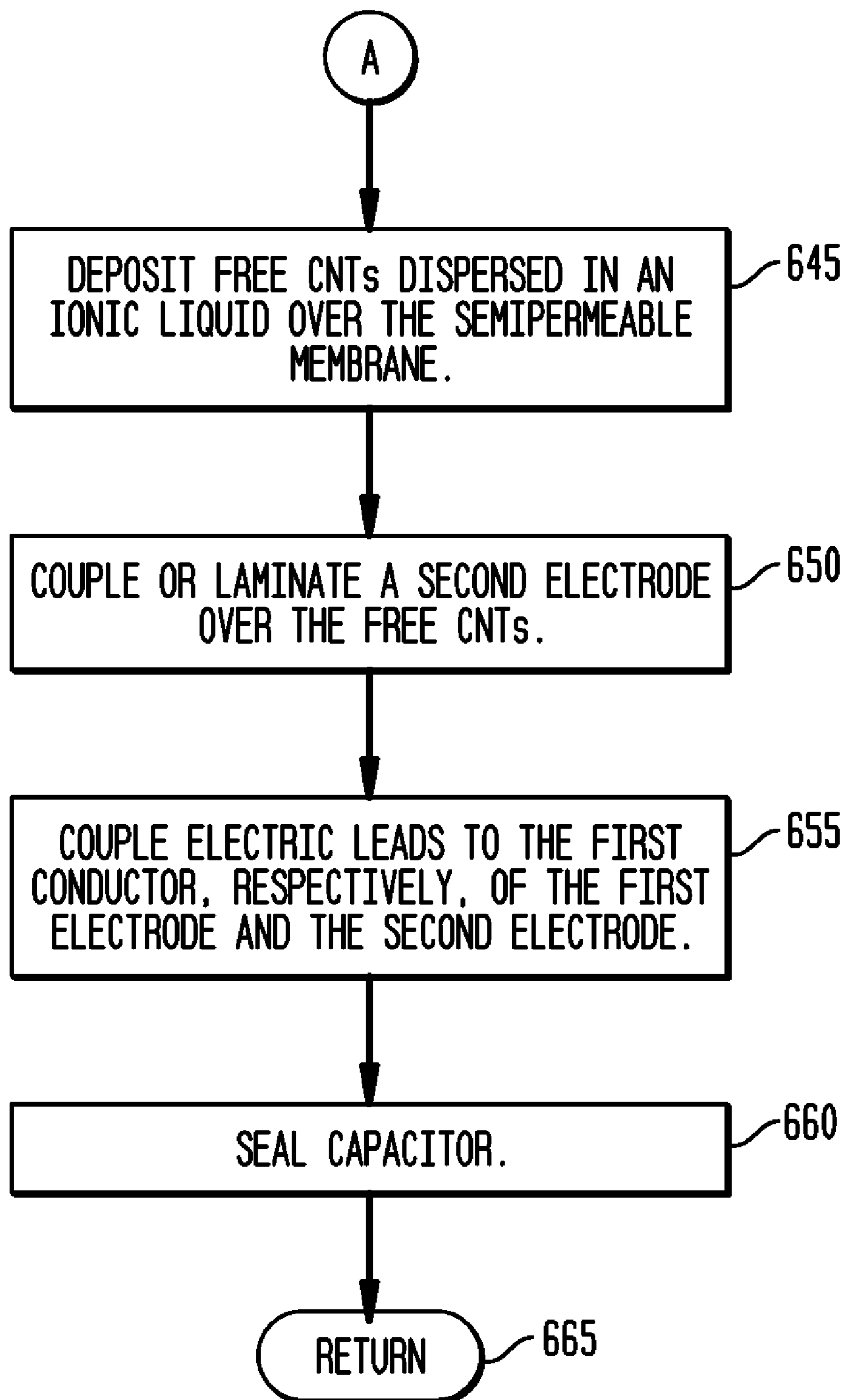

FIG. 16

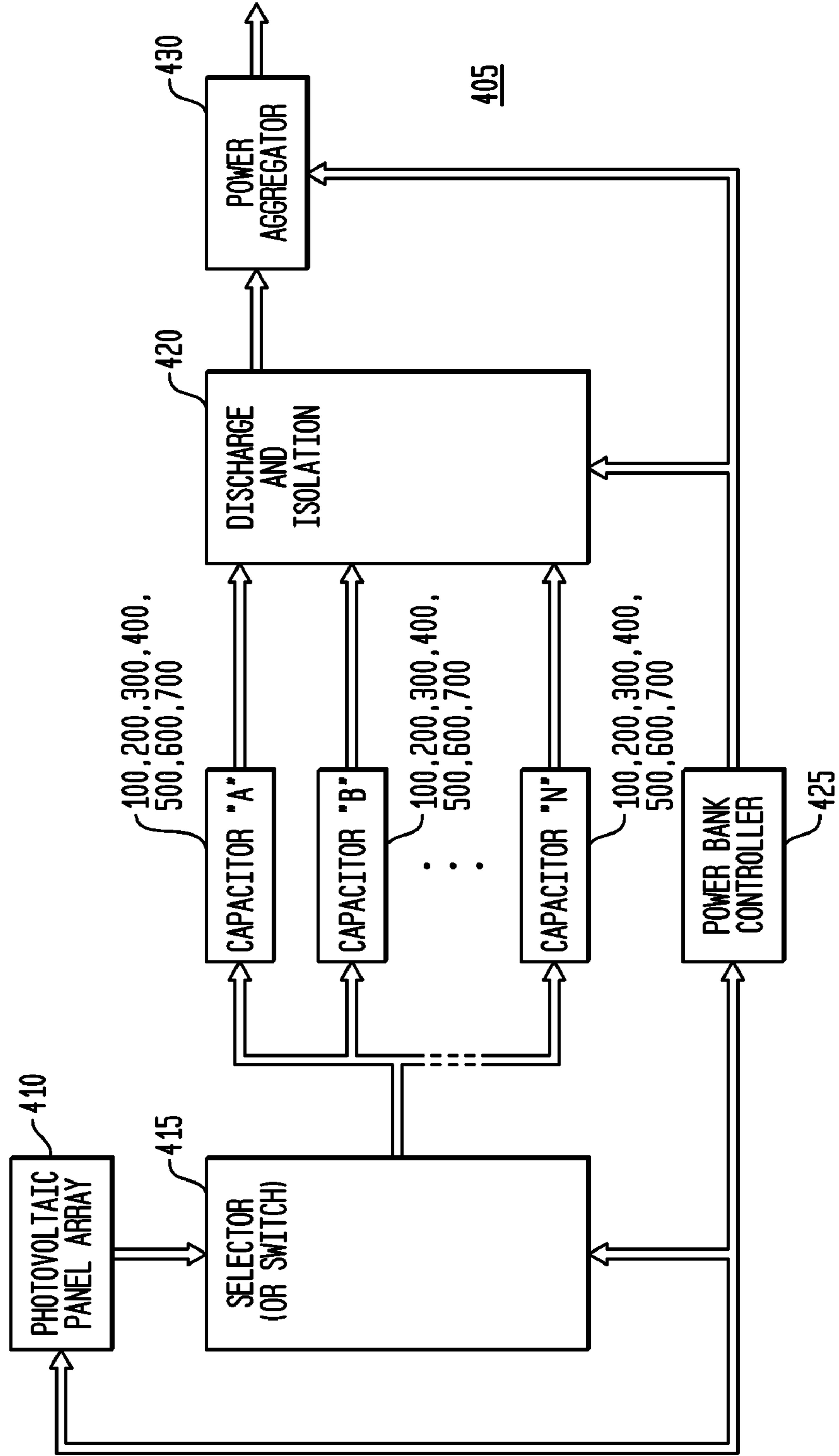
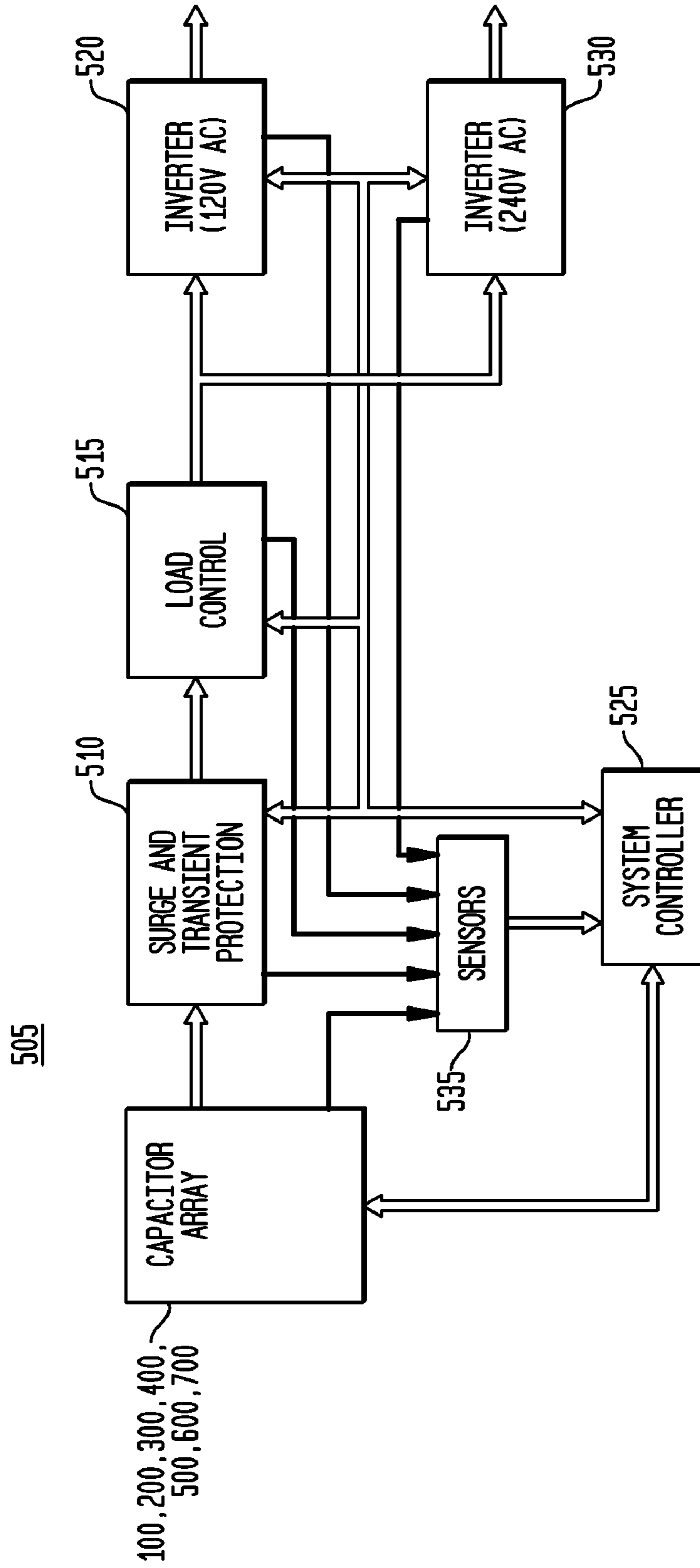

FIG. 17



## MULTILAYER CARBON NANOTUBE CAPACITOR

### CROSS-REFERENCE TO A RELATED APPLICATION

**[0001]** This application claims priority to and is a conversion of U.S. Provisional Patent Application Ser. No. 61/306,162, inventors William Johnstone Ray et al., entitled "System, Method and Apparatus for Printable Capacitors", which is commonly assigned herewith, the entire contents of which are incorporated herein by reference with the same full force and effect as if set forth in their entirety herein, and with priority claimed for all commonly disclosed subject matter.

### FIELD OF THE INVENTION

**[0002]** The present invention in general is related to energy storage technology and, in particular, is related to a multilayer carbon nanotube-based capacitor and methods of and printable compositions for manufacturing a multilayer carbon nanotube-based capacitor.

### BACKGROUND OF THE INVENTION

**[0003]** Current research into electrochemical supercapacitors (also referred to as ultracapacitors or electric double layer capacitors ("EDLCs")), has revealed that these devices may be promising local energy storage devices. Other available energy storage technologies such as the Faradaic battery and conventional dielectric capacitors have drawbacks. Batteries are characterized by high energy density, low power density, and short cycle life, while dielectric capacitors are low energy density, high power density and have a long cycle life. In contrast, supercapacitors potentially may be characterized by mid-range energy storage capability, high power density and long cycle life.

**[0004]** Three general types of supercapacitors may be identified, such as: (1) carbon-based active materials that store charge via high surface area; (2) oxidation-reduction ("redox" or pseudo-capacitors) which use fast and reversible surface or near surface reactions for charge storage (such as via transition metal oxides or conducting organic polymers); and (3) hybrid capacitors that combine capacitive or pseudo-capacitive electrodes with battery electrodes.

**[0005]** Carbon-based high surface area supercapacitors store electricity by physical charge separation. Supercapacitor charge is stored through reversible ion adsorption on high surface area electrodes. Carbon nanotubes ("CNTs") (such as single-walled carbon nanotubes ("SWCNTs") and multi-walled carbon nanotubes ("MWCNTs")) and carbon fibers have been explored for use in the electrodes of such carbon-based, high surface area supercapacitors, typically forming an intertwined, matted or entangled mesh layer limiting the available surface area for ion adsorption on the exterior of the fibers or nanotubes, and further having a very large variation in pore size.

**[0006]** Other attempts to use carbon nanotubes have included use of aligned CNTs having either a closed (capped) or an open (or uncapped) end, but have proved extraordinarily difficult to manufacture and scale up to commercial quantities. For example, capped CNTs have been grown directly on electrode plates to achieve some alignment; in another instance, carbon nanotubes have been aligned by growth of the CNTs through vacuum chemical vapor deposition on a silicon wafer substrate, then metallized and transferred by

hand to an electrode using a double-sided conducting tape, followed by plasma etching to uncap and open the ends and etch mesopores in the CNTs. While theoretically feasible, such alignment methods based on the growth of the CNTs are not practical beyond a laboratory environment. Further, such complicated CNT and capacitor fabrication processes are prohibitively expensive, are not scalable and have not been able to achieve commercial production. Such capacitor structures have not fully exploited the interior surfaces of the CNTs and the potential pore sizes of CNTs, have not addressed other methods of producing CNTs and the post-growth alignment of CNTs, and have not addressed specific energy density limitations of the resulting capacitors.

**[0007]** Accordingly, a need remains for methods of manufacturing a CNT-based capacitor using readily available commercial methods for fabricating CNTs and using post-growth alignment of the CNTs. Such a CNT-based capacitor should exploit the interior surfaces of the CNTs and the potential pore sizes of CNTs. Such a CNT-based capacitor should be capable of being manufactured at a commercial scale and comparatively low cost, while simultaneously providing comparatively high power density, high energy density, and long cycle life.

### SUMMARY

**[0008]** The exemplary capacitor embodiments have a structure different from the structures of prior art capacitors, a different fabrication method, and different compositions of matter. Various exemplary capacitor embodiments have an additional layer, namely, free CNTs which are translationally and/or rotationally moveable in an ionic liquid **140**. Many of the exemplary capacitor embodiments have a secondary support structure for the fixed CNTs, which provides a second support to the fixed CNTs at a second location which is separate and spaced apart from a first support location, such as the substrate. The fixed CNTs and the free CNTs are uncapped at least at one end, and have an interior diameter matched to be slightly greater than the ion size of a selected ionic liquid. The fixed CNTs have not been grown on an electrode or transferred directly from a growth plate, but have been dispersed in an ionic liquid and deposited with an irregular spacing over a first conductor, a conductive substrate, or a conductive nanomesh. In many embodiments, CNT-magnetic catalyst nanoparticle structures are aligned and moved by a magnetic field to couple the magnetic catalyst nanoparticles to the first conductor or conductive substrate. The CNT-magnetic catalyst nanoparticle structures in an ionic liquid also comprise a new and novel composition of matter. A novel conductive nanomesh comprised of deposited nanorods is utilized in exemplary embodiments for coupling CNTs to form fixed CNTs. Various exemplary capacitors provide greater energy density (or specific energy) than a traditional capacitor, and include a superposition of energy contributions from multiple sources, yielding a device which also exhibits characteristics of a traditional battery while still having the comparatively higher specific power (or power density) and longer cycle life of a traditional capacitor.

**[0009]** An exemplary capacitor comprises: a first conductor; a first plurality of fixed carbon nanotubes in an ionic liquid, each fixed carbon nanotube comprising a magnetic catalyst nanoparticle coupled to a carbon nanotube and further coupled to the first conductor; and a first plurality of free carbon nanotubes dispersed and moveable in the ionic liquid.

**[0010]** In an exemplary embodiment, for each fixed carbon nanotube of the first plurality of fixed carbon nanotubes, the magnetic catalyst nanoparticle coupled to the first conductor supports the carbon nanotube at a first location, and the capacitor further comprises: a support structure coupled to the first conductor and supporting one or more fixed carbon nanotubes of the first plurality of fixed carbon nanotubes at least at one or more second locations separate from and spaced apart from the first location. The support structure may be separate and distinct from the first plurality of fixed carbon nanotubes.

**[0011]** An exemplary support structure is a nanofiber support structure, which may be formed by electrospinning a polymer. In various exemplary embodiments, the polymer is at least one polymer selected from the group consisting of: polypyrrolle; polyaniline; polythiophene; polyterthiophene; derivatives of polythiophene and polyterthiophene; poly(3,4-ethylenedioxythiophene) (PEDOT); poly(3-(4-fluorophenyl)thiophene) (MPFT); poly(3-(3,4-difluorophenyl)thiophene) (MPFT); poly(3-(4-trifluoromethylphenyl)-thiophene) (PT-FMPT); poly(1-cyano-2-(2-(3,4-ethylenedioxythienyl))-1-(2-thienyl)vinylene (ThCNVEDT); poly(3-methylthiophene)(PMeT); and mixtures thereof. Another exemplary support structure is a screen and is spaced apart from the first conductor. In exemplary embodiments, the first conductor is coupled to a substrate or the first conductor is a conductive substrate. Another exemplary support structure is a plurality of elongated extensions or pillars extending from the substrate, or the first conductor, or the conductive substrate. Another exemplary support structure is a plurality of walls or sides of a plurality of cavities of the substrate, or the first conductor, or the conductive substrate.

**[0012]** In exemplary embodiments, for each fixed carbon nanotube, the magnetic catalyst nanoparticle is coupled to the carbon nanotube at a first end of the carbon nanotube, and each fixed carbon nanotube is open or uncapped at a second end opposite the first end coupled to the magnetic catalyst nanoparticle. In exemplary embodiments, each carbon nanotube of the first plurality of free carbon nanotubes is open or uncapped at least at one end. In exemplary embodiments, each fixed carbon nanotube of the first plurality of fixed carbon nanotubes is single-walled and each carbon nanotube of the first plurality of free carbon nanotubes is multi-walled or single-walled.

**[0013]** In various exemplary embodiments, each fixed carbon nanotube of the first plurality of fixed carbon nanotubes is substantially perpendicular to the plane of the first conductor.

**[0014]** In exemplary embodiments, each carbon nanotube of the first plurality of fixed carbon nanotubes and each carbon nanotube of the first plurality of free carbon nanotubes has an interior diameter greater than a Helmholtz diameter of an ion of the ionic liquid. In other exemplary embodiments, each carbon nanotube of the first plurality of fixed carbon nanotubes and each carbon nanotube of the first plurality of free carbon nanotubes has an interior diameter between about 0.5 nm and 1.5 nm.

**[0015]** In various exemplary embodiments, the ionic liquid is at least one ionic liquid selected from the group consisting of: butyltrimethylammonium bis(trifluoromethylsulfonyl)imide, 1-ethyl-3-methylimidazolium bis(trifluoromethylsulfonyl)imide, 1-methyl-3-propylimidazolium bis(trifluoromethylsulfonyl)imide, 1-hexyl-3-methylimidazolium bis(trifluoromethylsulfonyl)imide, 1-methyl-3-

propylimidazolium iodide, 1-ethyl-3-methylimidazolium thiocyanate, 1-methyl-1-propylpiperidinium bis(trifluoromethylsulfonyl)imide, 1-butyl-2-methylpyridinium bis(trifluoromethylsulfonyl)imide, 1-butyl-4-methylpyridinium bis(trifluoromethylsulfonyl)imide, 1-butyl-1-methylpyrrolidinium bis(trifluoromethylsulfonyl)imide, diethylmethylsulfonium bis(trifluoromethylsulfonyl)imide, lithium bis(trifluoromethylsulfonyl)imide, and mixtures thereof.

**[0016]** In exemplary embodiments, the magnetic catalyst nanoparticle is at least one catalyst selected from the group consisting of: cobalt, molybdenum, nickel, iron, ruthenium, mixtures thereof alloys thereof and their compounds. In various exemplary embodiments, at least some of the carbon nanotubes of the first plurality of fixed carbon nanotubes and at least some of the carbon nanotubes of the first plurality of free carbon nanotubes has a chirality of (n, m) where  $n=m$  or where the quotient of m minus n is divided by three ( $(m-n)/3$ ) is an integer.

**[0017]** In various exemplary embodiments, the capacitor further comprises a semipermeable membrane, such as polytetrafluoroethylene (PTFE).

**[0018]** In exemplary embodiments, the first plurality of free carbon nanotubes are not coupled to the first conductor, are not coupled to the first plurality of fixed carbon nanotubes, and are not coupled to the semipermeable membrane. Instead, the first plurality of free carbon nanotubes are translationally and rotationally moveable in the ionic liquid.

**[0019]** In various exemplary embodiments, the first plurality of fixed carbon nanotubes and the first conductor form a first electrode, and the capacitor further comprises: a semipermeable membrane between the first electrode and a second electrode, the second electrode comprising: a second conductor; a second plurality of fixed carbon nanotubes in the ionic liquid, each fixed carbon nanotube comprising a magnetic catalyst nanoparticle coupled to a carbon nanotube and further coupled to the second conductor; and a second plurality of free carbon nanotubes moveable in the ionic liquid.

**[0020]** Various methods of fabricating a capacitor are also disclosed. An exemplary method comprises: depositing a plurality of carbon nanotube-magnetic catalyst nanoparticle structures dispersed in an ionic liquid over a first conductor, each carbon nanotube-magnetic catalyst nanoparticle structure comprising a carbon nanotube coupled to a magnetic catalyst nanoparticle; using an applied magnetic field, aligning and moving the plurality of CNT-magnetic catalyst nanoparticle structures toward the first conductor; coupling the magnetic catalyst nanoparticles to the first conductor to form a first plurality of fixed carbon nanotubes; and depositing a first plurality of carbon nanotubes dispersed and moveable in an ionic liquid over the first plurality of fixed carbon nanotubes to form a first plurality of free carbon nanotubes.

**[0021]** In exemplary embodiments, prior to the step of depositing a plurality of carbon nanotube-magnetic catalyst nanoparticle structures, the method further comprises: providing a support structure coupled to the first conductor. In various exemplary embodiments, the step of providing a support structure further comprises: electrospinning a polymer over the first conductor to form the support structure. In other exemplary embodiments, the step of providing a support structure further comprises: attaching a screen or a mesh structure over and spaced apart from the first conductor. In various exemplary embodiments, the step of aligning and moving the plurality of CNT-magnetic catalyst nanoparticle structures toward the first conductor further comprises: using

the applied magnetic field, aligning and moving the plurality of CNT-magnetic catalyst nanoparticle structures through the support structure and toward the first conductor, or rotating and translating the plurality of CNT-magnetic catalyst nanoparticle structures toward the first conductor.

**[0022]** The exemplary method may further comprise: applying solder over the first conductor. The step of coupling the magnetic catalyst nanoparticles to the first conductor to form a first plurality of fixed carbon nanotubes may further comprise: heating the magnetic catalyst nanoparticles, the solder and the first conductor to bond the magnetic catalyst nanoparticles to the first conductor. The exemplary method may further comprise etching the first conductor.

**[0023]** The exemplary method may further comprise: coupling a semipermeable membrane over the first plurality of free carbon nanotubes; depositing a second plurality of carbon nanotubes dispersed and moveable in an ionic liquid over the semipermeable membrane to form a second plurality of free carbon nanotubes; and attaching a second electrode over the second plurality of free carbon nanotubes, the second electrode comprising a second plurality of fixed carbon nanotubes coupled to a second conductor.

**[0024]** In various exemplary embodiments, the step of depositing the plurality of carbon nanotube-magnetic catalyst nanoparticle structures may further comprise printing the plurality of carbon nanotube-magnetic catalyst nanoparticle structures dispersed in an ionic liquid over the first conductor. Also in various exemplary embodiments, the step of depositing the plurality of carbon nanotube-magnetic catalyst nanoparticle structures may further comprise printing the first plurality of carbon nanotubes dispersed and moveable in an ionic liquid over the first plurality of fixed carbon nanotubes.

**[0025]** In exemplary embodiments, a printable carbon nanotube composition comprises: an ionic liquid; and a plurality of carbon nanotube-magnetic catalyst nanoparticle structures dispersed in the ionic liquid, each carbon nanotube-magnetic catalyst nanoparticle structure comprising a carbon nanotube coupled to a magnetic catalyst nanoparticle.

**[0026]** In another exemplary embodiment, a capacitor comprises: a first conductor; a first conductive nanomesh coupled to the first conductor; a first plurality of fixed carbon nanotubes in an ionic liquid and further coupled to the first conductive nanomesh; and a first plurality of free carbon nanotubes dispersed and moveable in the ionic liquid.

**[0027]** In an exemplary embodiment, the first conductive nanomesh is metallic. In another exemplary embodiment, the first conductive nanomesh comprises gold or palladium nanorods. In another exemplary embodiment, the first conductive nanomesh comprises metallic nanorods having a diameter of less than about 100 nm and a length between about 200 nm and about 1.0 microns.

**[0028]** In various exemplary embodiments, each fixed carbon nanotube of the first plurality of fixed carbon nanotubes is substantially perpendicular to the plane of the first conductor. In various exemplary embodiments, at least some of the carbon nanotubes of the first plurality of fixed carbon nanotubes are metallic, conductive or ballistic.

**[0029]** In an exemplary embodiment, the first plurality of fixed carbon nanotubes, the first conductive nanomesh and the first conductor form a first electrode, and wherein the capacitor further comprises: a semipermeable membrane between the first electrode and a second electrode, the second electrode comprising: a second conductor; a second conductive nanomesh coupled to the second conductor; a second

plurality of fixed carbon nanotubes in an ionic liquid and further coupled to the second conductive nanomesh; and a second plurality of free carbon nanotubes dispersed and moveable in the ionic liquid.

**[0030]** Another exemplary method of fabricating a capacitor is disclosed. The exemplary method comprises: depositing a plurality of conductive nanorods over a first conductor to form a first conductive nanomesh; depositing a first plurality of carbon nanotubes dispersed in an ionic liquid over the first conductive nanomesh and the first conductor; using an applied electric field and an applied magnetic field, aligning and moving at least some of the carbon nanotubes of the first plurality of carbon nanotubes into the nanomesh and toward the first conductor; coupling at least some of the carbon nanotubes to the conductive nanomesh or to the first conductor to form a first plurality of fixed carbon nanotubes; and depositing a second plurality of carbon nanotubes dispersed and moveable in an ionic liquid over the first plurality of fixed carbon nanotubes to form a first plurality of free carbon nanotubes.

**[0031]** In various exemplary embodiments, the coupling step may further comprise applying heat to at least some of the carbon nanotubes, to the conductive nanomesh, and to the first conductor to form the first plurality of fixed carbon nanotubes.

**[0032]** In another exemplary embodiment, the coupling step may further comprise sintering at least some of the carbon nanotubes to the conductive nanomesh or to the first conductor to form the first plurality of fixed carbon nanotubes.

**[0033]** In various exemplary embodiments, the step of aligning and moving may further comprise rotating and translating at least some of the carbon nanotubes of the first plurality of carbon nanotubes into the nanomesh and toward the first conductor.

**[0034]** The exemplary method may further comprise etching the first conductor; coupling a semipermeable membrane over the first plurality of free carbon nanotubes; and depositing a third plurality of carbon nanotubes dispersed and moveable in an ionic liquid over the semipermeable membrane to form a second plurality of free carbon nanotubes.

**[0035]** In various exemplary embodiments, the first plurality of fixed carbon nanotubes coupled to the conductive nanomesh or the first conductor comprises a first electrode, and the exemplary method may further comprise attaching a second electrode over the second plurality of free carbon nanotubes, the second electrode comprising a second plurality of fixed carbon nanotubes coupled to a second conductive nanomesh or to a second conductor.

**[0036]** In various exemplary embodiments, the step of depositing the first plurality of carbon nanotubes may further comprise printing the plurality of carbon nanotubes dispersed in an ionic liquid over the first conductive nanomesh and the first conductor.

**[0037]** Numerous other advantages and features of the present invention will become readily apparent from the following detailed description of the invention and the embodiments thereof, from the claims and from the accompanying drawings.

#### BRIEF DESCRIPTION OF THE DRAWINGS

**[0038]** The objects, features and advantages of the present invention will be more readily appreciated upon reference to the following disclosure when considered in conjunction with

the accompanying drawings, wherein like reference numerals are used to identify identical components in the various views, and wherein reference numerals with alphabetic characters are utilized to identify additional types, instantiations or variations of a selected component embodiment in the various views, in which:

[0039] FIG. 1 is a perspective view illustrating an exemplary capacitor embodiment.

[0040] FIG. 2 is a cross-sectional view illustrating an exemplary first capacitor embodiment.

[0041] FIG. 3 is a cross-sectional view illustrating in greater detail fixed CNTs coupled through a magnetic catalyst nanoparticle to a first conductor to form an electrode.

[0042] FIG. 4 is a cross-sectional view illustrating in greater detail ion adsorption and packing in the interior of a carbon nanotube and ion adsorption on the exterior of a carbon nanotube.

[0043] FIG. 5 is a cross-sectional view illustrating an exemplary second capacitor embodiment.

[0044] FIG. 6 is a cross-sectional view illustrating an exemplary third capacitor embodiment.

[0045] FIG. 7 is a cross-sectional view illustrating an exemplary fourth capacitor embodiment.

[0046] FIG. 8 is a cross-sectional view illustrating an exemplary fifth capacitor embodiment.

[0047] FIG. 9 is a cross-sectional view illustrating an exemplary sixth capacitor embodiment.

[0048] FIG. 10, divided into FIGS. 10A and 10B, is a flow chart illustrating a first method of fabricating an exemplary multilayer carbon nanotube-based capacitor.

[0049] FIG. 11 is a block diagram illustrating an exemplary system for nanofiber electrospinning for formation of a secondary support structure.

[0050] FIG. 12 is a diagram illustrating in cross section the use of a magnetic field to orient the CNT-magnetic catalyst nanoparticle structures and couple the magnetic catalyst nanoparticles to the first conductor (or conductive substrate) to form fixed CNTs.

[0051] FIG. 13 is a diagram illustrating in cross section a plurality of fixed CNTs within a nanofiber support structure.

[0052] FIG. 14 is a cross-sectional view illustrating an exemplary seventh capacitor embodiment.

[0053] FIG. 15, divided into FIGS. 15A and 15B, is a flow chart illustrating a second method of fabricating an exemplary multilayer carbon nanotube-based capacitor.

[0054] FIG. 16 is a block diagram illustrating an exemplary first supercapacitor system embodiment.

[0055] FIG. 17 is a block diagram illustrating an exemplary second supercapacitor system embodiment.

#### DETAILED DESCRIPTION OF EXEMPLARY EMBODIMENTS

[0056] While the present invention is susceptible of embodiment in many different forms, there are shown in the drawings and will be described herein in detail specific exemplary embodiments thereof, with the understanding that the present disclosure is to be considered as an exemplification of the principles of the invention and is not intended to limit the invention to the specific embodiments illustrated. In this respect, before explaining at least one embodiment consistent with the present invention in detail, it is to be understood that the invention is not limited in its application to the details of construction and to the arrangements of components set forth above and below, illustrated in the drawings, or as described

in the examples. Methods and apparatuses consistent with the present invention are capable of other embodiments and of being practiced and carried out in various ways. Also, it is to be understood that the phraseology and terminology employed herein, as well as the abstract included below, are for the purposes of description and should not be regarded as limiting.

[0057] FIG. 1 is a perspective view illustrating an exemplary capacitor 100, 200, 300, 400, 500, 600, 700 embodiment. As illustrated, such an exemplary capacitor 100, 200, 300, 400, 500, 600, 700 is sealed or encapsulated with a sealant 35, to both provide electrical insulation and to prevent leakage of internal contents or components, such as CNTs and liquids. Also as illustrated, external leads (or wires) 15, 25 are provided for electrical contact with the corresponding capacitor electrodes (discussed in greater detail below). The sealant 35 and leads 15, 25 may be provided as known or becomes known in the electronic arts. The exemplary capacitor 100, 200, 300, 400, 500, 600, 700 may be stacked and wired in parallel or in series, and may perform as a capacitor, or a battery replacement, or as a fixed electrical “buffer” storage for distributed power systems. The exemplary capacitor 100, 200, 300, 400, 500, 600, 700 is illustrated as having a substantially flat form factor for ease of explanation, and those having skill in the electronic arts will understand that the exemplary capacitor 100, 200, 300, 400, 500, 600, 700 may have any of various forms, such as rolled, folded, etc., and any and all such shapes and sizes are considered equivalent and within the scope of the disclosure. For example and as discussed in greater detail below, an exemplary capacitor 100, 200, 300, 400, 500, 600, 700 may be formed through a printing process on comparatively large, flexible sheets of a substrate 105, such that the exemplary capacitor 100, 200, 300, 400, 500, 600, 700 may also be flexible and formed into a wide variety of shapes for any intended purpose.

[0058] Also as discussed in greater detail below, the various exemplary capacitors 100, 200, 300, 400, 500, 600, 700 differ from each other based upon various internal structures and compositions, which may be selected or combined in any combination, with all such combinations also considered equivalent and within the scope of the disclosure. It should be noted that the various cross-sectional views of FIGS. 2 and 5-9 do not illustrate the sealant (or sealing layer) 35 or the leads 15, 25, and those having skill in the art will recognize that those features are readily added to any of the exemplary capacitors 100, 200, 300, 400, 500, 600, 700. It also should be noted that the various cross-sectional views of FIGS. 2 and 5-9 are exploded views for purposes of illustration and are not drawn to scale, with any physical capacitors 100, 200, 300, 400, 500, 600, 700 being considerably more compact and typically formed into any of a plurality of shapes and sizes.

[0059] FIG. 2 is a cross-sectional view (through the 20-20' plane of FIG. 1) illustrating an exemplary first capacitor 100 embodiment. Exemplary first capacitor 100 comprises two different types of carbon nanotube (“CNT”) structures, fixed CNTs 120, 120A (which are fixed, coupled or attached to a first conductor 110) and free (unattached, uncoupled or free floating) CNTs 130, both in an ionic liquid 140. The fixed CNTs 120, 120A and the free CNTs 130 may be single-walled (SWCNTs) or multi-walled (MWCNTs). In an exemplary embodiment, the fixed CNTs 120, 120A are typically single-walled and the free CNTs 130 are typically MWCNTs or a mixture of MWCNTs and SWCNTs. The fixed CNTs 120 and free CNTs 130 may have any chirality; in an exemplary



embodiment, a reasonably high percentage (e.g., 30-40%) of both the fixed CNTs **120** and the free CNTs **130** have a chirality which exhibits “metallic” or ballistic conductivity (e.g., a conductor or conductive chirality, such as “arm-chair” chirality (chiral vector of (n, m) where n=m or where m minus n is divisible by 3 to produce an integer quotient or is zero), such as (1,1) chirality)), with the balance exhibiting a semiconductor or other chirality, and either or both conductive and semiconductive CNTs may be utilized. In another variation described below (with reference to FIGS. **14** and **15**), the fixed CNTs **120A** are primarily or predominantly conductive (metallic or ballistic), and the free CNTs **130** are typically or predominantly semiconductive.

[0060] As discussed in greater detail below, both the fixed CNTs **120**, **120A** and the free CNTs **130** are uncapped or open at least one end **145**, to allow ion adsorption or penetration into the interior of the fixed CNTs **120**, **120A** and the free CNTs **130**, in addition to ion adsorption on the exterior of the fixed CNTs **120**, **120A** and the free CNTs **130**, as illustrated in greater detail in FIG. **4** with a positively charged ion **165**. The fixed CNTs **120**, **120A** are aligned to be substantially perpendicular or orthogonal to the plane of the substrate **105**, **105A** and/or the first conductor **110** (and immersed in the ionic liquid **140**) (to form a reasonably densely packed “forest” of fixed CNTs **120**, **120A**, but with sufficient spacing to allow ion adsorption on the exterior walls of the fixed CNTs **120**), while the free CNTs **130** generally are randomly dispersed and substantially or at least somewhat free to move in the ionic liquid **140**. The open (uncapped) ends **145** of the fixed CNTs **120**, **120A** on the opposing first and second electrodes **150**, **155** generally face each other to facilitate ion transport during charge and discharge cycles and perform significantly better than merely chaotically or randomly positioned nanocavities of the prior art.

[0061] In exemplary embodiments, the interior diameters of the fixed CNTs **120**, **120A** and the free CNTs **130** will have some variation, generally with a known or approximate statistical variance, but are generally matched or selected to be slightly larger than the ion sizes (Helmholtz diameter) of the anions and cations of the selected ionic liquid **140**, allowing ions to enter into and pack the interior of the fixed CNTs **120**, **120A** and the free CNTs **130**, similarly to the packing of a “Roman candle”. In an exemplary embodiment, the interior diameter of the fixed CNTs **120**, **120A** and the free CNTs **130** is less than about 5 nm, or more preferably less than about 4 nm, or more preferably less than about 3 nm, or more preferably less than about 2 nm, or more preferably less than about 1 nm. In an exemplary embodiment, the interior diameter of the fixed CNTs **120** and the free CNTs **130** is between about 0.5 nm and 1.5 nm. In another exemplary embodiment, the interior diameter of the fixed CNTs **120**, **120A** and the free CNTs **130** is about 0.7 nm. In another exemplary embodiment, there are multiple interior diameters of the fixed CNTs **120**, **120A** and the free CNTs **130**, generally within a predetermined variance, and may be utilized to accommodate more than one ionic liquid having different ion sizes. In an exemplary embodiment, the fixed CNTs **120**, **120A** and the free CNTs **130** have lengths on the order of about 20  $\mu\text{m}$ , or more preferably less than about 10  $\mu\text{m}$ , or more preferably less than about 5  $\mu\text{m}$ , or more preferably less than about 2  $\mu\text{m}$ , or more preferably between about 0.5  $\mu\text{m}$  to 1.5  $\mu\text{m}$ .

[0062] FIG. **3** is a cross-sectional view illustrating in greater detail fixed CNTs **120** coupled through a magnetic catalyst nanoparticle **125** to a first conductor **110** to form a

first electrode **150** and a second electrode **155**, which may be either an anode or a cathode. In exemplary embodiments, the fixed CNTs **120**, **120A** (and also free CNTs **130**) have been grown in a fluid-bed reactor using any of various catalysts, such as “seed” or catalyst nanoparticles of cobalt, molybdenum, or a combination of cobalt and molybdenum, with the CNTs growing epitaxially from the catalyst nanoparticles. In exemplary embodiments, and a significant departure from prior art, the CNTs used to form the fixed CNTs **120** have not been cleaved from the catalyst nanoparticles during fabrication and remain attached, specifically at one, non-open end, to the catalyst nanoparticles post-fabrication. The catalyst nanoparticles are magnetic, such as comprising cobalt or cobalt-molybdenum, forming magnetic catalyst nanoparticles **125** which are utilized to align, couple and attach the fixed CNTs **120** to the first conductor **110**, as discussed in greater detail below, forming a densely packed “forest” of aligned, fixed CNTs **120**. The magnetic catalyst nanoparticle **125** is specifically at one, non-open end of a fixed CNT **120** (or free CNT **130**), and is not in the middle or otherwise embedded further into the interior of the CNT. In exemplary embodiments, one or a plurality of CNTs may be coupled to a magnetic catalyst nanoparticle **125**, also as illustrated. The free CNTs **130** may or may not be attached to the catalyst particles used in their fabrication, and are illustrated in both forms in FIG. **2**. A CNT coupled to the magnetic catalyst nanoparticle **125**, which may be utilized to form either or both fixed CNTs **120** and free CNTs **130** (when the free CNTs **130** which are utilized have the magnetic catalyst nanoparticle **125**), is also referred to herein as a “CNT-magnetic catalyst nanoparticle structure” **175**, depending upon the context, to differentiate it during fabrication, as a CNT-magnetic catalyst nanoparticle structure **175** during deposition and alignment, prior to becoming coupled to the first conductor **110** or conductive substrate **105A** and thereby becoming a fixed CNT **120**. In exemplary embodiments, the fixed CNTs **120**, **120A** and the free CNTs **130** are open or uncapped at least at one end **145**, and the free CNTs **130** and fixed CNTs **120A** may be uncapped and open at one or both ends **145** (depending upon whether they are coupled to a magnetic catalyst nanoparticle **125**). The CNTs utilized to form the fixed CNTs **120** having the magnetic catalyst nanoparticles **125**, the fixed CNTs **120A**, and the free CNTs **130** (with or without the magnetic catalyst nanoparticles **125**) and being uncapped or open at least at one end **145** may be obtained, for example and without limitation, from SouthWest NanoTechnologies, Inc., at 2501 Technology Place, Norman, Okla. 73071, USA.

[0063] In another, seventh exemplary embodiment (**700**) described below, the fixed CNTs **120A** may or may not have the magnetic catalyst nanoparticle **125**, and are illustrated without the magnetic catalyst nanoparticle **125**. For that embodiment, magnetic and electric fields are utilized to align and move (rotationally and translationally) the CNTs into contact with a conductive (e.g., metallic) nanomesh, as discussed in greater detail below.

[0064] Referring to FIGS. **2** and **3**, the first conductor **110** is illustrated as coupled to a substrate **105**. In any of various exemplary embodiments, the first conductor **110** and the substrate **105** are not separate components, and instead may be formed as a combined or integrated conductive substrate **105A** (illustrated in FIG. **7**). The fixed CNTs **120** are coupled to the first conductor **110** or to a conductive substrate **105A**, such as through a soldered, sintered, alloyed, or conductive adhesive connection, and respectively form first electrode

**150** and second electrode **155**. The first electrode **150** (with free CNTs **130** in an ionic liquid **140**) and the second electrode **155** (with free CNTs **130** in an ionic liquid **140**) are separated from each other by a semipermeable membrane **115** having a pore size sufficiently large to allow comparatively unimpeded ion flow while preventing touching or other physical contact (and shorting) between the first electrode **150** and the second electrode **155**. In various exemplary embodiments, the first electrode **150** and the second electrode **155** may be configured as parallel plates or sheets (prior to further configuration, such as folding or rolling), each having a substantially flat form factor, and may be flexible or non-flexible. In other exemplary embodiments, such as the capacitor **600** embodiment illustrated in FIG. 9, the first electrode **150** and the second electrode **155** are each fan-folded and may be flexible or nonflexible. The capacitors **100, 200, 300, 400, 500, 600, 700** also may have any of various overall, resulting shapes, sizes, and form factors, such as by further folding or rolling of the opposing electrodes (with their sandwiched contents, the ionic liquid **140** and the free CNTs **130** on each side of the semipermeable membrane **115**).

[0065] It should be noted that the exemplary capacitors **100, 200, 300, 400, 500, 600, 700** are effectively comprised of two, mirror image halves, with one half having the first electrode **150** and the other half having the second electrode **155**. The second electrode **155** may be fabricated identically to the first electrode **150**, and then placed (upside down or face down, effectively as a mirror image) over the first electrode **150** and additional components (free CNTs **130**, semipermeable membrane **115**, and free CNTs **130**), such as by lamination. (As a consequence, it should be noted that in various contexts, the first conductor **110** in the second electrode **155** may need to be differentiated from the first conductor **110** in the first electrode **150**. Therefore, the first conductor **110** in the second electrode **155** may also be referred to herein as a “second conductor” as the context may require, in the claims for example, simply to differentiate it from the first conductor **110** in the first electrode **150**; it should be understood that such a reference to a “second conductor” is referring to a first conductor **110** in the second electrode **155** to differentiate it in a context which also refers to the first conductor **110** in the first electrode **150**.)

[0066] The free CNTs **130** are not coupled to other structures within the capacitor **100 (200, 300, 400, 500, 600, 700)**, but to some degree, some of the free CNTs **130** may form or have formed attachments to each other, also as illustrated in FIG. 2. In addition, it is possible that some of the free CNTs **130** could conceivably form some type of attachments to the fixed CNTs **120** or the semipermeable membrane **115** or the sealant **35**, such as due to frictional forces, Van Der Waals forces or manufacturing process variation, for example and without limitation. Nonetheless, in exemplary embodiments, at least most or the majority of the free CNTs **130** are uncoupled to the fixed structures within a capacitor **100, 200, 300, 400, 500, 600, 700**, such as uncoupled to the fixed CNTs **120, 120A**, the first electrode **150**, and the semipermeable membrane **115**, and are effectively floating or otherwise free to move in the ionic liquid **140**, such that the free CNTs **130** are generally movable in their entireties and will move translationally and/or rotationally in response to an electric field, for both charging and discharging the capacitor **100**. This type of movement is to be contrasted to the potential movement of fixed CNTs **120, 120A** or CNTs utilized in prior art capacitors, in which one end may be free to move and undulate to

some degree, analogously to the movement of blades of grass in the wind, but are not free to rotate or translate in their entireties.

[0067] To preserve exterior surface area, the free CNTs **130** generally are dispersed within the ionic liquid **140** with minimal or comparatively slight formation of any matting or entanglement. The free CNTs **130** are utilized not only to provide additional interior and exterior surface area for ion adsorption, but also to physically impede or otherwise slow the rate of ion movement during charge and discharge through their physical translational and/or rotational movement within the ionic liquid **140**, in direct opposition to prior art. The packing (and queuing) of ions with the interior of the fixed CNTs **120, 120A** and the free CNTs **130** will also serve to impede or delay ion movement, with charge and discharge occurring more sequentially as ions individually enter or exit the opening of the fixed CNTs **120** and the free CNTs **130**. This effect serves to extend the time period over which charge and discharge may occur and provide comparatively higher energy density (or specific energy), yielding a device which may also exhibit characteristics of a traditional battery.

[0068] As mentioned above, the exemplary capacitor **100, 200, 300, 400, 500, 600, 700** embodiments may be formed through a printing or other deposition processes, such as through screen, flexographic or Gravure printing. A first conductor **110** is deposited on the substrate **105**, such as using a conductive ink. Alternatively, a conductive substrate **105A** may be utilized, such as a metal foil or sheet. As discussed in greater detail below, a scaffolding or other support structure is also formed or attached, such as a nanofiber support structure **170** formed through electrospinning of a polymer and illustrated in FIGS. 5 and 13. CNT-magnetic catalyst nanoparticle structures **175** (i.e., the CNTs having the magnetic catalyst nanoparticles **125** that will form the fixed CNTs **120**) are dispersed in an ionic liquid **140** and deposited over the first conductor **110** (or conductive substrate **105A**) and any support structure **170**, with a magnetic field applied to pull the magnetic catalyst nanoparticle **125** (with attached CNT) down to the first conductor **110** (or conductive substrate **105A**) or to pull the magnetic catalyst nanoparticle **125** (with attached CNT) through the support structure **170** and down to the first conductor **110** (or conductive substrate **105A**), such that the magnetic catalyst nanoparticles **125** may be electrically coupled to the first conductor **110** (or conductive substrate **105A**) to thereby form the fixed CNTs **120** which are aligned about or substantially perpendicular to the first conductor **110** (or conductive substrate **105A**), forming a first (or second) electrode **150 (155)**. Heat or electromagnetic radiation (e.g., uv light) may be applied to couple (bond or cure) the magnetic catalyst nanoparticles **125** to the first conductor **110** (or conductive substrate **105A**), and with the corresponding attached CNTs, form the fixed CNTs **120**. An additional electric field may also be applied to align or orient the CNT portion of the fixed CNTs **120**, particularly as additional CNTs are coupled to the first conductor **110** (or conductive substrate **105A**). The free CNTs **130** (also dispersed in an ionic liquid **140**, and which may or may not have magnetic catalyst nanoparticles **125**) are deposited over the fixed CNTs **120**, forming a first half of a capacitor **100, 200, 300, 400, 500, 600, 700**, followed by deposition or other attachment of the semipermeable membrane **115**. Additional free CNTs **130** (also immersed in an ionic liquid **140**) are deposited over the semipermeable membrane **115**, followed by deposition of a second (or first) electrode **155 (or 150)**, formed as described

above for a first (or second) electrode **150** (**155**), such as by folding, lamination or other placement, as described in greater detail below. Electric leads **15**, **25** are attached to the first conductor **110** (or conductive substrate **105A**) of each electrode **150**, **155**, and the device may be sealed (sealant **35**), forming a capacitor **100**, **200**, **300**, **400**, **500**, **600**, **700**.

**[0069]** Ionic liquids are molten-salts that at room temperature have immeasurably low vapor pressure, are non-flammable, have high ionic conductivity, have a wide range of thermal and electrochemical stabilities, and are capable of dispersing various forms of CNTs. An ionic liquid **140** may be selected based upon stability over time and temperature, a comparatively wide electrochemical window or decomposition voltage, comparatively high conductivity, capability to disperse CNTs, a lack of corrosiveness (for other components, such as the CNTs and conductors), purity (e.g., hydrophobic, with water being the most typical impurity), and aprotic characteristics (to avoid hydrogen ion discharge at the cathodes). The ionic liquid **140** utilized herein may be comprised of any one or more ionic liquids and mixtures of combinations thereof, including for example and without limitation: butyltrimethylammonium bis(trifluoromethylsulfonyl)imide, 1-ethyl-3-methylimidazolium bis(trifluoromethylsulfonyl)imide, 1-methyl-3-propylimidazolium bis(trifluoromethylsulfonyl)imide, 1-hexyl-3-methylimidazolium bis(trifluoromethylsulfonyl)imide, 1-methyl-3-propylimidazolium iodide, 1-ethyl-3-methylimidazolium thiocyanate, 1-methyl-1-propylpiperidinium bis(trifluoromethylsulfonyl)imide, 1-butyl-2-methylpyridinium bis(trifluoromethylsulfonyl)imide, 1-butyl-4-methylpyridinium bis(trifluoromethylsulfonyl)imide, 1-butyl-1-methylpyrrolidinium bis(trifluoromethylsulfonyl)imide, diethylmethylsulfonium bis(trifluoromethylsulfonyl)imide, lithium bis(trifluoromethylsulfonyl)imide, and mixtures thereof. Other ionic liquids as utilized in the electronic and electrochemical arts may also be suitable, and are considered equivalent and within the scope of the disclosure.

**[0070]** The magnetic catalyst nanoparticles **125** may be comprised of any of various magnetic materials, including without limitation cobalt, molybdenum, nickel, iron, ruthenium, combinations and alloys thereof such as or cobalt-molybdenum, and their compounds.

**[0071]** The semipermeable membrane **115** may be comprised of any suitable material, including without limitation a polytetrafluoroethylene (PTFE or Teflon) membrane, such as a 23  $\mu\text{m}$  thick PTFE membrane having a pore size of about 0.05  $\mu\text{m}$  and a porosity of 50-70%, available from WL Gore & Associates. Another suitable semipermeable membrane **115** may be Celgard™ thin film available from Celgard LLP, also for example and without limitation. The types and compositions of other components of the exemplary capacitor **100**, **200**, **300**, **400**, **500**, **600**, **700** embodiments, such as substrates **105**, **105A** and first conductors **110** are described in greater detail below.

**[0072]** The substrate (or base) **105** may be comprised of any suitable material, such as plastic, paper, cardboard, or coated paper or cardboard, for example and without limitation. The substrate **105** may comprise any flexible or nonflexible material having the strength and degree of electrical insulation to withstand the intended use conditions. In an exemplary embodiment, a substrate **105** comprises a polyester or plastic sheet, such as a CT-7 seven mil polyester sheet treated for print receptiveness commercially available from MacDermid Autotype, Inc. of MacDermid, Inc. of Denver, Colo., USA,

for example. In another exemplary embodiment, a substrate **105** comprises a polyimide film such as Kapton commercially available from DuPont, Inc. of Wilmington Del., USA, also for example. Also in an exemplary embodiment, substrate **105** comprises a material having a dielectric constant capable of or suitable for providing sufficient electrical insulation for the excitation and discharge voltages which may be selected. A substrate **105** may comprise, also for example, any one or more of the following: paper, coated paper, plastic coated paper, fiber paper, cardboard, poster paper, poster board, books, magazines, newspapers, wooden boards, plywood, and other paper or wood-based products in any selected form; plastic or polymer materials in any selected form (sheets, film, boards, and so on); natural and synthetic rubber materials and products in any selected form; natural and synthetic fabrics in any selected form; glass, ceramic, and other silicon or silica-derived materials and products, in any selected form; building materials and products; or any other product, currently existing or created in the future. In a first exemplary embodiment, a substrate **105** may be selected which provides a degree of electrical insulation (i.e., has a dielectric constant or insulating properties sufficient to provide electrical insulation of the one or more first conductors **110** deposited or applied on a first (front) side of the substrate **105**), either electrical insulation from each other or from other apparatus or system components. For example, while comparatively expensive choices, a glass sheet or a silicon wafer also could be utilized as a substrate **105**. In other exemplary embodiments, however, a plastic sheet or a plastic-coated paper product is utilized to form the substrate **105** such as the polyester mentioned above or patent stock and 100 lb. cover stock available from Sappi, Ltd., or similar coated papers from other paper manufacturers such as Mitsubishi Paper Mills, Mead, and other paper products. In another exemplary embodiment, an embossed plastic sheet or a plastic-coated paper product having a plurality of grooves, also available from Sappi, Ltd. is utilized, with the grooves utilized for forming the conductors **110**. Suitable substrates **105** also potentially include extruded polyolefinic films, including LDPE films; polymeric nonwovens, including carded, melt-blown and spunbond nonwovens, and cellulosic paper. The substrate **105** may also comprise laminates of any of the foregoing materials. Two or more laminae may be adhesively joined, thermally bonded, or autogenously bonded together to form the laminate comprising the substrate. If desired, the laminae may be embossed.

**[0073]** The exemplary substrate **105**, **105A** as illustrated in the various Figures have a form factor which is substantially flat in an overall sense, such as comprising a sheet of a selected material (e.g., paper or plastic) which may be fed through a printing press, for example and without limitation, and which may have a topology on a first surface (or side) which includes surface roughness, cavities, channels or grooves or having a first surface which is substantially smooth within a predetermined tolerance (and does not include cavities, channels or grooves). Those having skill in the art will recognize that innumerable, additional shapes and surface topologies are available, are considered equivalent and within the scope of the disclosure.

**[0074]** The first conductor **110** may be comprised of any suitable material, applied or deposited (on a first side or surface of the substrate **105**), such as through a printing process, to a thickness depending upon the type of conductive ink or polymer, such as to about 0.1 to 6 microns (e.g., about

3 microns for a typical silver ink, gold ink, aluminum ink, and to less than one micron for a nanosilver ink). In an exemplary method of manufacturing the exemplary capacitor **100**, **200**, **300**, **400**, **500**, **600**, **700** embodiments, a conductive ink, polymer, or other conductive liquid or gel (such as a silver (Ag) ink or polymer, a nano silver ink composition, a carbon nanotube ink or polymer, or silver/carbon mixture such as amorphous nanocarbon (having particle sizes between about 75-100 nm) dispersed in a silver ink) is deposited on a substrate **105**, **105A**, such as through a printing or other deposition process, and may be subsequently cured or partially cured (such as through an ultraviolet (uv) curing process), to form the one or more first conductors **110**. In another exemplary embodiment, the one or more first conductors **110** may be formed by sputtering, spin casting (or spin coating), vapor deposition, or electroplating of a conductive compound or element, such as a metal (e.g., aluminum, copper, silver, gold, nickel, palladium). Combinations of different types of conductors and/or conductive compounds or materials (e.g., ink, polymer, elemental metal, etc.) may also be utilized to generate one or more composite first conductors **110**. Multiple layers and/or types of metal or other conductive materials may be combined to form the one or more first conductors **110**. In various exemplary embodiments, a plurality of first conductors **110** are deposited, and in other embodiments, a first conductor **110** may be deposited as a single conductive sheet or otherwise attached (e.g., a sheet of aluminum coupled to a substrate **105**) (not separately illustrated).

[0075] In an exemplary embodiment, depending upon the applied thickness, the first conductor **110** also may be etched to create nano-sized cavities or pores, on the order of 5-10 nm, which may also be filled with a solder, to facilitate attachment of the magnetic catalyst nanoparticles **125**. In another exemplary embodiment, depending upon the applied thickness, the first conductor **110** also may be sanded to smooth the surface and also may be calendarized to compress the conductive particles, such as silver.

[0076] Other conductive inks or materials may also be utilized to form the one or more first conductors **110**, such as copper, tin, aluminum, gold, noble metals, carbon, carbon black, single or double or multi-walled CNTs, graphene, graphene platelets, nanographene platelets, nanocarbon and nanocarbon and silver compositions, nano silver compositions (including nanosilver fiber and nanosilver particle inks), or other organic or inorganic conductive polymers, inks, gels or other liquid or semi-solid materials. In an exemplary embodiment, carbon black (having a particle diameter of about 100 nm) is added to a silver ink to have a resulting carbon concentration in the range of about 0.025% to 0.1%. In addition, any other printable or coatable conductive substances may be utilized equivalently to form the first conductor(s) **110**, and exemplary conductive compounds include: (1) from Conductive Compounds (Londonberry, NH, USA), AG-500, AG-800 and AG-510 Silver conductive inks, which may also include an additional coating UV-1006S ultraviolet curable dielectric (such as part of a first dielectric layer **125**); (2) from DuPont, 7102 Carbon Conductor (if overprinting 5000 Ag), 7105 Carbon Conductor, 5000 Silver Conductor, 7144 Carbon Conductor (with UV Encapsulants), 7152 Carbon Conductor (with **7165** Encapsulant), and 9145 Silver Conductor; (3) from SunPoly, Inc., 128A Silver conductive ink, 129A Silver and Carbon Conductive Ink, 140A Conductive Ink, and 150A Silver Conductive Ink; (4) from Dow Corning, Inc., PI-2000 Series Highly Conductive Silver Ink;

(5) from Henkel/Emerson & Cumings, Electrodag 725A; and (6) Monarch M120 available from Cabot Corporation of Boston, Mass., USA, for use as a carbon black additive, such as to a silver ink to form a mixture of carbon and silver ink. In addition, conductive inks and compounds may be available from a wide variety of other sources.

[0077] A conductive substrate **105A** may be any type of prefabricated substrate **105** discussed above which has been coated or otherwise has deposited a conductor or conductive layer (e.g., a first conductor as described above). A conductive substrate **105A** may be any type of conductor, mixture of conductors, alloys of conductors, etc., including those discussed above, which has or have a form factor suitable for deposition of the CNTs such as, for example and without limitation, a conductive foil or sheet, such as an aluminum foil, a nickel foil, a carbon foil, a CNT foil, a graphene foil, a silver foil, a gold foil, an iron sheet, a steel sheet, other types of sheet metal, etc.

[0078] Conductive polymers which are substantially optically transmissive may also be utilized to form the one or more first conductors **110**. For example, polyethylene-dioxithiophene may be utilized, such as the polyethylene-dioxithiophene commercially available under the trade name "Orgacon" from AGFA Corp. of Ridgefield Park, N.J., USA, in addition to any of the other transmissive conductors discussed below and their equivalents. Other conductive polymers, without limitation, which may be utilized equivalently include polyaniline and polypyrrole polymers, for example. In another exemplary embodiment, carbon nanotubes which have been suspended or dispersed in a polymerizable ionic liquid or other fluids are utilized to form various conductors which are substantially optically transmissive or transparent.

[0079] Organic semiconductors, variously called  $\pi$ -conjugated polymers, conducting polymers, or synthetic metals, are inherently semiconductive due to  $\pi$ -conjugation between carbon atoms along the polymer backbone. Their structure contains a one-dimensional organic backbone which enables electrical conduction following n- or p+ type doping. Well-studied classes of organic conductive polymers include poly(acetylene)s, poly(pyrrole)s, poly(thiophene)s, polyanilines, polythiophenes, poly(p-phenylene sulfide), poly(para-phenylene vinylene)s (PPV) and PPV derivatives, poly(3-alkylthiophenes), polyindole, polypyrene, polycarbazole, polyazulene, polyazepine, poly(fluorene)s, and polynaphthalene. Other examples include polyaniline, polyaniline derivatives, polythiophene, polythiophene derivatives, polypyrrole, polypyrrole derivatives, polythianaphthene, polythianaphthene derivatives, polyparaphenylene, polyparaphenylene derivatives, polyacetylene, polyacetylene derivatives, polydiacetylene, polydiacetylene derivatives, polyparaphenylenevinylene, polyparaphenylenevinylene derivatives, polynaphthalene, and polynaphthalene derivatives, polyisothianaphthene (PITN), polyheteroarylenvinylene (ParV), in which the heteroarylene group can be, e.g., thiophene, furan or pyrrol, polyphenylene-sulphide (PPS), polyperinaphthalene (PPN), polyphthalocyanine (PPhc) etc., and their derivatives, copolymers thereof and mixtures thereof. As used herein, the term derivatives means the polymer is made from monomers substituted with side chains or groups.

[0080] The method for polymerizing the conductive polymers is not particularly limited, and the usable methods include uv or other electromagnetic polymerization, heat polymerization, electrolytic oxidation polymerization, chemical oxidation polymerization, and catalytic polymer-

ization, for example and without limitation. The polymer obtained by the polymerizing method is often neutral and not conductive until doped. Therefore, the polymer is subjected to p-doping or n-doping to be transformed into a conductive polymer. The semiconductor polymer may be doped chemically, or electrochemically. The substance used for the doping is not particularly limited; generally, a substance capable of accepting an electron pair, such as a Lewis acid, is used. Examples include hydrochloric acid, sulfuric acid, organic sulfonic acid derivatives such as parasulfonic acid, polystyrenesulfonic acid, alkylbenzenesulfonic acid, camphorsulfonic acid, alkylsulfonic acid, sulfosalicylic acid, etc., ferric chloride, copper chloride, and iron sulfate.

[0081] Those having skill in the electronic or printing arts will recognize innumerable variations in the ways in which the one or more first conductors 110 may be formed, with all such variations considered equivalent and within the scope of the disclosure. For example, the one or more first conductors 110 may also be deposited through sputtering or vapor deposition, without limitation. In addition, for other various embodiments, the one or more first conductors 110 may be deposited as a single or continuous layer, such as through coating, printing, sputtering, or vapor deposition. Those having skill in the electronic or printing arts also will recognize innumerable variations in the ways in which the CNTs 120, 130 dispersed in an ionic liquid may be deposited, such as through printing, with all such variations considered equivalent and within the scope of the disclosure.

[0082] As a consequence, as used herein, “deposition” includes any and all printing, coating, rolling, spraying, layering, sputtering, plating, spin casting (or spin coating), vapor deposition, lamination, affixing and/or other deposition processes, whether impact or non-impact, known in the art. “Printing” includes any and all printing, coating, rolling, spraying, layering, spin coating, lamination and/or affixing processes, whether impact or non-impact, known in the art, and specifically includes, for example and without limitation, screen printing, inkjet printing, electro-optical printing, electroink printing, photoresist and other resist printing, thermal printing, laser jet printing, magnetic printing, pad printing, flexographic printing, hybrid offset lithography, Gravure and other intaglio printing, for example. All such processes are considered deposition processes herein and may be utilized. The exemplary deposition or printing processes do not require significant manufacturing controls or restrictions. No specific temperatures or pressures are required. Some clean room or filtered air may be useful, but potentially at a level consistent with the standards of known printing or other deposition processes. For consistency, however, such as for proper alignment (registration) of the various successively deposited layers forming the various embodiments, relatively constant temperature (with possible exceptions, discussed below, such as for applied heat for bonding magnetic catalyst nanoparticles 125 to a first conductor 110 or conductive substrate 105A) and humidity may be desirable. In addition, the various compounds utilized may be contained within various polymers, binders or other dispersion agents which may be heat-cured or dried, air dried under ambient conditions, or IR or UV cured.

[0083] It should also be noted, generally for any of the applications of various compounds herein, such as through printing or other deposition, the surface properties or surface energies may also be controlled, such as through the use of resist coatings or by otherwise modifying the “wettability” of

such a surface, for example, by modifying the hydrophilic, hydrophobic, or electrical (positive or negative charge) characteristics, for example, of surfaces such as the surface of the substrate 105, 105A, the surfaces of the various first conductors 110, and/or other surfaces formed during fabrication. In conjunction with the characteristics of the compound, suspension, polymer or ink being deposited, such as the surface tension, the deposited compounds may be made to adhere to desired or selected locations, and effectively repelled from other areas or regions.

[0084] FIG. 5 is a cross-sectional view (through the 20-20' plane of FIG. 1) illustrating an exemplary second capacitor 200 embodiment. The exemplary second capacitor 200 embodiment further includes a support structure 170 mentioned above, and is otherwise substantially similar or identical to the exemplary first capacitor 100 embodiment. For this embodiment, the support structure 170 is a nanofiber support structure 170 formed through an electrospinning process, as discussed in greater detail below, and is generally formed separately from a substrate 105, 105A. An exemplary nanofiber support structure 170 is also illustrated in FIG. 13. The support structure 170 provides a secondary (or second) support for the fixed CNTs 120 at a second location separate, distinct and spaced apart from a first or primary location of support for the fixed CNTs 120 provided by the first conductor 110 (or conductive substrate 105A) at the point or area of attachment of the magnetic catalyst nanoparticle 125. The support structure 170 generally will provide this additional support to some or many (but generally not all) of the fixed CNTs 120, serving to maintain alignment of the fixed CNTs 120 generally or mostly perpendicular to the first conductor 110 (or conductive substrate 105A), thereby preventing excessive curvature and/or excessive entanglement of the fixed CNTs 120, allowing a higher density of fixed CNTs 120 on the first conductor 110 (or conductive substrate 105A) and increasing available surface area for ion adsorption. The fixed CNTs 120 which are in contact with the support structure 170 generally will serve to provide support for adjacent fixed CNTs 120 which are not in direct contact with the support structure 170, which in turn may also support other adjacent, fixed CNTs 120, and so on. As mentioned above, an exemplary support structure 170 may be formed by electrospinning of a polymer, typically prior to deposition of the CNTs which will form the fixed CNTs 120 in an ionic liquid 140. As part of the electrospinning process, the nanofiber support structure 170 is fabricated to have pores, voids or opening sizes sufficient to allow passage and pulling of the CNT-magnetic catalyst nanoparticle structures for coupling of the magnetic catalyst nanoparticle 125 to the first conductor 110 (or conductive substrate 105A) to form the fixed CNTs 120.

[0085] FIG. 6 is a cross-sectional view (through the 20-20' plane of FIG. 1) illustrating an exemplary third capacitor 300 embodiment. The exemplary third capacitor 300 embodiment also includes a support structure 170A, and is otherwise also substantially similar or identical to the exemplary first capacitor 100 embodiment. The support structure 170A is provided as a screen or mesh configuration, spaced apart from the first conductor 110 (or conductive substrate 105A) (such as by using posts (or spacers) 195 integrated with or formed as part of the substrate 105, 105A or the support structure 170A), and also provides a support for the fixed CNTs 120 at a second location separate, distinct and spaced apart from a first or primary location of support for the fixed CNTs 120 provided by the first conductor 110 (or conductive substrate 105A) at

the point or area of attachment of the magnetic catalyst nanoparticle **125**. The support structure **170A** generally also will provide this additional support to some or many (but generally not all) of the fixed CNTs **120**, serving to maintain alignment of the fixed CNTs **120** generally perpendicular to the first conductor **110** (or conductive substrate **105A**), thereby also preventing excessive curvature and/or excessive entanglement of the fixed CNTs **120**, also allowing a higher density of fixed CNTs **120** and increasing available surface area for ion adsorption. The fixed CNTs **120** which are in contact with the support structure **170** generally will also serve to provide support for adjacent fixed CNTs **120** which are not in direct contact with the support structure **170**, which in turn may also support other adjacent, fixed CNTs **120**, and so on. As mentioned above, an exemplary support structure **170A** may be prefabricated as a screen or mesh structure and attached over and spaced apart from the first conductor **110** (or conductive substrate **105A**), with the support structure **170A** having a pore or opening size sufficient to allow passage and pulling of the CNT-magnetic catalyst nanoparticle structures for coupling of the magnetic catalyst nanoparticle **125** to the first conductor **110** (or conductive substrate **105A**) to form the fixed CNTs **120**. The openings or pores in the screen or mesh support structure **170A** are visible in FIG. 6 in the upper half of the cross section of exemplary capacitor **300**. In an exemplary embodiment, the support structure **170A** comprises a polymer screen; in another exemplary embodiment, the support structure **170A** comprises a comparatively sparse mesh of CNTs (separate from the fixed CNTs **120** and the free CNTs **130**).

[0086] FIG. 7 is a cross-sectional view (through the 20-20' plane of FIG. 1) illustrating an exemplary fourth capacitor **400** embodiment. The exemplary fourth capacitor **400** embodiment also includes an integrated support structure **170B** and illustrates a conductive substrate **105A**, and is otherwise also substantially similar or identical to the exemplary first capacitor **100** embodiment. The support structure **170B** is provided as a series of elongated pillars or columns **180**, extending from the conductive substrate **105A** (or first conductor **110**), and also provides a support for the fixed CNTs **120** at a second location separate, distinct and spaced apart from a first or primary location of support for the fixed CNTs **120** provided by the conductive substrate **105A** (or first conductor **110**) at the point or area of attachment of the magnetic catalyst nanoparticle **125**. The support structure **170B** generally also will provide this additional support to some or many (but generally not all) of the fixed CNTs **120**, serving to maintain alignment of the fixed CNTs **120** generally perpendicular to the plane of the conductive substrate **105A** (or first conductor **110**), thereby also preventing excessive curvature and/or excessive entanglement of the fixed CNTs **120**, also allowing a higher density of fixed CNTs **120** and increasing available surface area for ion adsorption. The fixed CNTs **120** which are in contact with the support structure **170B** generally will also serve to provide support for adjacent fixed CNTs **120** which are not in direct contact with the support structure **170B**, which in turn may also support other adjacent, fixed CNTs **120**, and so on. In this exemplary embodiment, the support structure **170B** may be formed integrally with the substrate **105** or conductive substrate **105A**, e.g., as a textured or embossed surface, with the support structure **170B** having voids or openings between the pillars or columns **180** with a size sufficient to allow passage and pulling of the CNT-magnetic catalyst nanoparticle structures

for coupling of the magnetic catalyst nanoparticle **125** to the conductive substrate **105A** (or first conductor **110**) to form the fixed CNTs **120**.

[0087] FIG. 8 is a cross-sectional view (through the 20-20' plane of FIG. 1) illustrating an exemplary fifth capacitor **500** embodiment. The exemplary fifth capacitor **500** embodiment also includes a plurality of cavities, wells, grooves, channels or cavities **190**, the walls or sides **192** of which form an integrated support structure **170C**, and is otherwise also substantially similar or identical to the exemplary first capacitor **100** embodiment. The support structure **170C** is provided as a series of walls or sides of the cavities **190**, extending from the first conductor **110** (or conductive substrate **105A**), and also provides a support for the fixed CNTs **120** at a second location separate, distinct and spaced apart from a first or primary location of support for the fixed CNTs **120** provided by the first conductor **110** (or conductive substrate **105A**) at the point or area of attachment of the magnetic catalyst nanoparticle **125**. The support structure **170C** generally also will provide this additional support to some or many (but generally not all) of the fixed CNTs **120**, serving to maintain alignment of the fixed CNTs **120** generally perpendicular to the first conductor **110** (or conductive substrate **105A**), thereby also preventing excessive curvature and/or excessive entanglement of the fixed CNTs **120**, also allowing a higher density of fixed CNTs **120** and increasing available surface area for ion adsorption. The fixed CNTs **120** which are in contact with the support structure **170C** generally will also serve to provide support for adjacent fixed CNTs **120** which are not in direct contact with the support structure **170C**, which in turn may also support other adjacent, fixed CNTs **120**, and so on. In this exemplary embodiment, the support structure **170C** may be formed integrally with the substrate **105** or conductive substrate **105A**, e.g., as a textured or embossed surface, or may be formed as part of the first conductor **110**, with the cavities **190** having a size sufficient to allow passage and pulling of the CNT-magnetic catalyst nanoparticle structures for coupling of the magnetic catalyst nanoparticle **125** to the first conductor **110** (or conductive substrate **105A**) to form the fixed CNTs **120**.

[0088] For example, the substrate **105** may include a plurality of cavities (or voids) **190**, which for the selected embodiment, may be formed as elongated cavities, effectively forming channels, grooves or slots (or, equivalently, depressions, valleys, bores, openings, gaps, orifices, hollows, slits, or passages), or may be shaped to be substantially circular or elliptical depressions or bores, for example and without limitation. Accordingly, any reference herein to cavities **190** shall be understood to mean and include the other, or any other cavity of any shape or size. The plurality of cavities **190** are spaced-apart, and may also be utilized to define a "holding well" for the fixed CNTs **120**. While the cavities or channels **190** are illustrated in FIG. 9 as substantially parallel and oriented in the same direction, those having skill in the art will recognize that innumerable variations are available, including depth and width of the channels, channel orientation (e.g., circular, elliptical, curvilinear, wavy, sinusoidal, triangular, fanciful, artistic, etc.), spacing variations, type of void or cavity (e.g., channel, depression or bore), etc., and all such variations are considered equivalent and within the scope of the present invention.

[0089] FIG. 9 is a cross-sectional view (through the 20-20' plane of FIG. 1) illustrating an exemplary sixth capacitor **600** embodiment. The exemplary sixth capacitor **600** embodiment

is initially fabricated as a substantially flat structure and then provided with a “fan fold”. The folding may occur during fabrication of the first electrode **150** and the second electrode **155**, or may occur after the capacitor **600** is assembled but prior to sealing. For example, the substrate **105**, **105A** may be provided with scoring or other demarcation to facilitate such folding. The exemplary sixth capacitor **600** embodiment includes posts (or spacers) **197** to offset the first and second electrodes **150**, **155** from each other, and has the fixed CNTs **120** in any of a plurality of orientations or alignments, not merely generally perpendicular, and is otherwise also substantially similar to the exemplary first capacitor **100** embodiment, including the use of the free CNTs **130**. In this exemplary embodiment, the fixed CNTs **120** are coupled to the first conductor **110** or conductive substrate **105A** through the magnetic catalyst nanoparticle **125**, but otherwise may have or assume any orientation, as illustrated. Also in this exemplary embodiment, the fixed CNTs **120** may or may not be aligned and pulled magnetically to the first conductor **110** or conductive substrate **105A**, but may simply be deposited over and coupled to the first conductor **110** or conductive substrate **105A**.

[0090] As mentioned above, it is believed that the exemplary capacitor **100**, **200**, **300**, **400**, **500**, **600**, **700** embodiments do not have a simple exponential drop in voltage over time of the classical capacitor (e.g.,  $e^{-t/\tau}$ , where  $\tau$  is an RC time constant). Instead, the voltage drop is delayed due to the separate contributions of the different charge storing components (e.g., a superposition of the contributions of the different components) and the movement of the free CNTs **130** in the ionic liquid. For example, discharge may occur due to the ion movement away from the exterior of the fixed CNTs **120** and the free CNTs **130** ( $\tau_1$ ), with additional discharge from ion movement out of the interior of the fixed CNTs **120** and/or the free CNTs **130** ( $\tau_2$ ), and with additional delayed ion movement due to the movement of the free CNTs **130** ( $\tau_3$ ), each of which may occur at different rates, resulting in a superposition of these separate contributions, resulting in a higher energy density (or specific energy), yielding a device also exhibits characteristics of a traditional battery while still having the comparatively higher specific power (or power density) and longer cycle life of a traditional capacitor.

[0091] FIG. 10 (divided into FIGS. 10A and 10B) is a flow chart illustrating a first method of fabricating the exemplary multilayer carbon nanotube-based capacitor, such as the exemplary capacitor **100**, **200**, **300**, **400**, **500**, **600** embodiments. FIG. 11 is a block diagram illustrating an exemplary system for nanofiber electrospinning for formation of a nanofiber secondary support structure **170**. FIG. 12 is a diagram illustrating in cross section the use of a magnetic field to orient the CNT-magnetic catalyst nanoparticle structures **175** and couple the magnetic catalyst nanoparticles **125** to the first conductor **110** (or conductive substrate **105A**) to form fixed CNTs **120**. FIG. 13 is a diagram illustrating in cross section a plurality of fixed CNTs **120** within a nanofiber support structure **170**. As mentioned above, the exemplary capacitor **100**, **200**, **300**, **400**, **500**, **600**, **700** embodiments may be formed through a printing or other deposition processes, such as through screen, flexographic or Gravure printing.

[0092] Referring to FIG. 10, beginning with start step **205**, a first conductor **110** is deposited on the substrate **105**, such as by printing a conductive ink or a conductive ink followed by a conductive adhesive, step **210**. Alternatively, step **210** may be omitted when a conductive substrate **105A** is utilized, such

as a metal foil. A secondary support structure **170** is also deposited or attached, step **215**, such as through electrospinning of a polymer over the first conductor **110** (or conductive substrate **105A**) or attachment or lamination of a screen-type secondary support structure **170A**. The CNT-magnetic catalyst nanoparticle structures **175** which have been dispersed in an ionic liquid **140** (and which will form the fixed CNTs **120**) are deposited over the first conductor **110** (or conductive substrate **105A**) and any secondary support structure **170**, step **220**. As illustrated in FIG. 12, a magnetic field is applied, step **225**, to pull the magnetic catalyst nanoparticle **125** (with attached CNT) toward or down to the first conductor **110** (or conductive substrate **105A**) or to pull the magnetic catalyst nanoparticle **125** (with attached CNT) through the support structure **170** and toward or down to the first conductor **110** (or conductive substrate **105A**) (as illustrated in FIG. 13), such that the magnetic catalyst nanoparticles **125** may be electrically coupled to the first conductor **110** (or conductive substrate **105A**), step **230**, with the fixed CNTs **120** also aligned about or substantially perpendicular to the first conductor **110** (or conductive substrate **105A**) in selected embodiments, forming a first (or second) electrode **150** (**155**). In step **230**, heat or electromagnetic radiation (e.g., uv light) may be applied to couple (bond or cure) the magnetic catalyst nanoparticles **125** to the first conductor **110** (or conductive substrate **105A**), to thereby form the fixed CNTs **120**. Such bonding may include soldering, sintering, alloying, or forming a conductive adhesive bond. An additional electric field may also be applied in step **230** to align or orient the CNT portion of the fixed CNTs **120**, particularly as additional CNTs are coupled to the first conductor **110** (or conductive substrate **105A**). A first plurality of the free CNTs **130** (also dispersed in an ionic liquid **140**) are deposited over the fixed CNTs **120**, step **235**, followed by deposition or other attachment of the semipermeable membrane **115**, step **240**. An additional, second plurality of free CNTs **130** (also dispersed in an ionic liquid **140**) are deposited over the semipermeable membrane **115**, step **245**, followed by deposition of a second (or first) electrode **155** (or **150**), formed as described above for a first (or second) electrode **150** (**155**), such as by folding, lamination, or other placement step **250**. It should be noted that step **245** may be omitted when the second electrode is formed using the same substrate and is folded over to form the capacitor, in which case the free CNTs **130** have been deposited in step **235**, the semipermeable membrane **115** coupled over the first electrode in step **240**, with the second electrode (with free CNTs **130** from step **235**) folded over on top of the first electrode. Electric leads **15**, **25** are attached to the first conductor **110** (or conductive substrate **105A**) of each electrode **150**, **155**, step **255**, and the device is sealed (sealant **35**), step **260**, forming a capacitor **100**, **200**, **300**, **400**, **500**, **600**, and the method may end, step **265**. Not separately illustrated, there may be additional curing steps prior to deposition of additional layers, such as curing of an electrospun nanofiber secondary support structure **170** prior to deposition of the CNT-magnetic catalyst nanoparticle structures.

[0093] For example, first conductors **110** may be formed as two separate areas on a substrate **105**, step **210**, with steps **215** through **230** performed for each separate area, forming first and second electrodes **150**, **155**. Step **245** (deposition of the free CNTs **130**), step **250** (attachment of a semipermeable membrane **115**), and step **255** (deposition of the free CNTs **130** over the semipermeable membrane **115**) are performed for a first electrode **150**. The second electrode **155**, having

been fabricated one the second area of the same substrate **105**, may then be attached or coupled by folding the substrate **105**, **105A**, placing the second electrode **155** over the free CNTs **130**, semipermeable membrane **115**, free CNTs **130**, and first electrode **150**.

[0094] Referring to FIG. **11**, an exemplary system **305** for nanofiber electrospinning for formation of a secondary support structure **170** comprises a syringe **310** coupled to a syringe pump **315**, with a polymer held in the syringe **310** and ejected through a needle **320** (which functions as an electrode and is subjected to a voltage, such as a positive voltage), with the needle **320** held by a needle holder (having a fine movement controller) **325**. The polymer which will form the nanofiber is ejected through the needle **320** toward the negative (or grounded negative) electrode **330** which, in conjunction with the movement of the needle **320** and variations in the electric field location, allows the ejected polymer to be shaped (as it is spun onto the substrate **105**, **105A** held above the electrode **330**) to create the nanofiber support structure **170**, such as the nanofiber support structure **170** illustrated in FIG. **13**. Fiber density and thickness may also be controlled by varying the distance between the electrodes, polymer concentration, time and rate of the polymer supply, etc. Also as illustrated, power supply **335** provides the corresponding voltages to the needle **320** and negative electrode **330**. Any other system and method of electrospinning which is known or becomes known in the art may also be utilized equivalently and is considered within the scope of the disclosure.

[0095] The nanofiber support structure **170** may be comprised of a conductive polymer and further contribute to increasing the capacitance of the capacitor **200**, **300**, **400** embodiments. There are three basic groups of conductive polymers (conjugated polymers) which are considered useful for conductive-polymer-based supercapacitors, including without limitation: (1) polypyrrole; (2) polyaniline; and (3) derivatives of polythiophene and polyterthiophene, such as: poly(3,4-ethylenedioxythiophene) (PEDOT), poly(3-(4-fluorophenyl)thiophene) (MPFT), poly(3-(3,4-difluorophenyl)thiophene) (MPFT), poly(3-(4-trifluoromethylphenyl)thiophene) (PTFMPT), poly(1-cyano-2-(2-(3,4-ethylenedioxythienyl))-1-(2-thienyl)vinylene (ThCNVEDT), poly(3-methyl thiophene)(PMeT); and mixtures thereof. Additives such as other polymers and CNTs (single or multiwall) may be included in the polymer mixture to improve properties of the nanofibers such as mechanical strength, surface area, average thickness of fibers, and conductivity.

[0096] The nanofiber support structure **170** also may be comprised of a nonconductive polymer, which may have greater solubilities and require less aggressive or corrosive solvents. Such nonconductive polymers may also be doped or mixed with carbon nanotubes, amorphous carbon or metals to become conductive to some extent and also contribute to the overall capacitance of the devices. Water-soluble polymers (e.g., polyethylene oxide, polyvinyl alcohol) may be advantageous as enabling use of non-toxic solvents.

[0097] An exemplary nanofiber support structure **170** is on the order of about 0.5  $\mu\text{m}$  to 1.5  $\mu\text{m}$  in height. In an exemplary embodiment, the diameter of a fiber of the nanofiber support structure **170** is on the order of about 20-30 nm, although smaller diameters may also be utilized and are within the scope of the disclosure. Also in an exemplary embodiment, the spaces between fibers of the nanofiber support structure **170** is on the order of about 5-7 nm, although smaller or larger

spaces may also be utilized and are within the scope of the disclosure. The nanofiber support structure **170** may also be etched to create additional surface area for ion adsorption.

[0098] FIG. **12** is a diagram illustrating in cross section the use of a magnetic field to orient the CNT-magnetic catalyst nanoparticle structures **175** and couple the magnetic catalyst nanoparticles **125** to the first conductor **110** (or conductive substrate **105A**) to form fixed CNTs **120**. As illustrated, a substrate **105A** (or a substrate **105** with a first conductor **110**) having a support structure **170**, in this case a nanofiber support structure **170**, is moving laterally (direction **183**) over support rollers **182** and a magnet **185** (which may be a permanent magnet or an electromagnet), as CNT-magnetic catalyst nanoparticle structures **175** dispersed in an ionic liquid **140** are deposited over the nanofiber support structure **170**, such as part of a printing or other deposition process. Not separately illustrated, the conductive substrate **105A** or the first conductor **110** may further have or comprise layer of solder or other bonding agent, such as a solder comprising nickel beads coated with bismuth, for example and without limitation. As the CNT-magnetic catalyst nanoparticle structures **175** enter the magnetic field, they are rotated and translated within the ionic liquid **140**, being pulled and aligned (or oriented) by the force on the magnetic catalyst nanoparticles **125** from the magnetic field and toward the substrate **105A** or first conductor **110**, analogously to the movement of a shuttlecock through the air. As the magnetic catalyst nanoparticles **125** contact or are within a predetermined distance from the conductive substrate **105A** (or first conductor **110**), heat (or other infrared or electromagnetic radiation) is applied, such as through a heat generator **184**, to bond the magnetic catalyst nanoparticles **125** to the conductive substrate **105A** or first conductor **110** to form fixed CNTs **120**, such as by melting any applied solder or sintering the magnetic catalyst nanoparticles **125** with the conductive substrate **105A** or first conductor **110**, for example and without limitation. In addition, not separately illustrated, an electric field may also be applied to create an additional force to align (orient) and maintain the CNT portion of the CNT-magnetic seed nanoparticle structure **175** generally perpendicular to the plane of the conductive substrate **105A** or first conductor **110** (with substrate **105**).

[0099] For the sake of completeness, it should be noted that the conductive substrate **105A** or first conductor **110** may be magnetic or nonmagnetic, and generally will be nonmagnetic in many embodiments (e.g., comprised of aluminum, or silver, or carbon), as discussed in greater detail below.

[0100] Exemplary aligned, fixed CNTs **120**, having magnetic catalyst nanoparticles **125** bonded to the substrate **105A** and/or first conductor **110**, and with the CNT portion of the CNT-magnetic seed nanoparticle structure **175** generally perpendicular to the plane of the conductive substrate **105A** or first conductor **110** (with substrate **105**) and supported by a nanofiber support structure **170**, is illustrated in FIG. **13**. It should be noted, however, that while the CNT portions of the fixed CNTs **120** are illustrated as substantially straight and perpendicular for ease of illustration, those having skill in the art will recognize that the fixed CNTs **120**, **120A** will generally have some degree of curvature, bending, spiraling, and potential undulation within the ionic liquid **140**.

[0101] FIG. **14** is a cross-sectional view (through the **20-20'** plane of FIG. **1**) illustrating an exemplary seventh capacitor **700** embodiment. The exemplary seventh capacitor **700** embodiment also includes a support structure **170D** com-



prised of a conductive (or metallic) nanomesh **95**, and utilizes fixed CNTs **120A**, which may or may not include magnetic catalyst nanoparticles **125** (and are illustrated without magnetic catalyst nanoparticles **125**), utilizes a plurality of cavities (as previously discussed), and is otherwise also substantially similar or identical to the exemplary first capacitor **100** embodiment. In addition, the exemplary seventh capacitor **700** embodiment may also be fabricated slightly differently, as illustrated and discussed below with reference to FIG. **15**. The support structure **170D** is provided as a mesh configuration. Conductive (or metallic) nanorods (or, equivalently, nano rods), such as gold or palladium nanorods, having a diameter less than about 100 nm and having a wide range of lengths (e.g., 200 nm to 1.5  $\mu\text{m}$ , or more preferably 200 nm to 1.0  $\mu\text{m}$ , or more preferably 300 nm to 1.0  $\mu\text{m}$ , for example and without limitation) are deposited above or on top of the first conductor **110** (or conductive substrate **105A**), and form a mesh **95**, into which the (conductive or ballistic) CNTs will become entangled and coupled (e.g., by sintering), to form the fixed CNTs **120A**. In addition to providing support, the nanomesh **95** also makes one or more electrical connections to the CNTs and to the first conductor **110**, so that the fixed CNTs **120A** are electrically coupled to the first conductor **110** through the nanomesh **95**, in addition to any direct electrical couplings between the fixed CNTs **120A** and the first conductor **110**. The support structure **170D** (nanomesh **95**) also provides a support for the fixed CNTs **120A** at one or more second locations separate, distinct and spaced apart from a first or primary location of support for the fixed CNTs **120A** provided by the first conductor **110** (or conductive substrate **105A**) or another (first) location on the support structure **170D**. The support structure **170D** generally also will provide this additional support or electrical coupling to some or many (but generally not all) of the deposited CNTs, with those CNTs which are coupled thereby forming the fixed CNTs **120A**, serving to maintain alignment of the fixed CNTs **120A** generally perpendicular to the first conductor **110** (or conductive substrate **105A**), and thereby also preventing excessive curvature and/or excessive entanglement of the fixed CNTs **120A**, also allowing a higher density of fixed CNTs **120A** and increasing available surface area for ion adsorption. An exemplary support structure **170D**, formed as a metallic or conductive nanomesh **95**, will typically have a pore or opening size sufficient to allow passage and pulling of the (conductive or ballistic) CNTs for coupling of the (conductive or ballistic) CNTs to the first conductor **110** (or conductive substrate **105A**) or to the nanomesh **95** to form the fixed CNTs **120A**.

[0102] FIG. **15**, divided into FIGS. **15A** and **15B**, is a flow chart illustrating a second method of fabricating an exemplary multilayer carbon nanotube-based capacitor, such as exemplary seventh capacitor **700** embodiment. Referring to FIG. **15**, beginning with start step **605**, a first conductor **110** is deposited on the substrate **105**, such as by printing a conductive ink or a conductive ink followed by a conductive adhesive, step **610**. Alternatively, step **610** may be omitted when a conductive substrate **105A** is utilized, such as a metal foil. Conductive (or metallic) nanorods, having a diameter less than about 100 nm and having a wide range of lengths (e.g., 200 nm to 1.5  $\mu\text{m}$ , or more preferably 200 nm to 1.0  $\mu\text{m}$ , or more preferably 300 nm to 1.0  $\mu\text{m}$ , for example and without limitation) are deposited above or on top of the first conductor **110** (or conductive substrate **105A**), and form a nanomesh **95**, step **615**. A mixture of a plurality of conductive or ballistic CNTs and semiconductive CNTs (with or more likely without

magnetic catalyst nanoparticles **125**) which have been dispersed in an ionic liquid **140** (and some of which will form the fixed CNTs **120A**) are deposited over the nanomesh **95** and first conductor **110** (or conductive substrate **105A**), step **620**. Alternatively, as a variation of step **620**, a plurality of conductive or ballistic CNTs (without semiconductive CNTs, and also generally without magnetic catalyst nanoparticles **125**) which have been dispersed in an ionic liquid **140** (and some of which will form the fixed CNTs **120A**) may be deposited over the nanomesh **95** and first conductor **110** (or conductive substrate **105A**).

[0103] Similarly to the illustration of FIG. **12**, an electric field and a magnetic field are applied, step **625**, using the electric field to align the conductive or ballistic CNTs and using the magnetic field to pull the conductive or ballistic CNTs toward and down into the nanomesh **95**, and to some extent through the nanomesh **95** and toward or down to the first conductor **110** (or conductive substrate **105A**) (similar to the illustration in FIG. **13**). It should be noted that the conductive or ballistic CNTs will respond much more strongly to the electric and magnetic fields compared to the semiconductive CNTs. In this way, the conductive or ballistic CNTs differentially may be electrically coupled to the nanomesh **95** and/or first conductor **110** (or conductive substrate **105A**) to form fixed CNTs **120A**, step **630**, with the fixed CNTs **120A** also aligned about or substantially perpendicular to the first conductor **110** (or conductive substrate **105A**) in selected embodiments, forming a first (or second) electrode **150** (**155**). In step **630**, heat (e.g., sintering at 130 degrees C.) or electromagnetic radiation (e.g., uv light) may be applied to couple (bond or cure) the conductive or ballistic CNTs to the nanomesh **95** and/or first conductor **110** (or conductive substrate **105A**), to thereby form the fixed CNTs **120A**, and also to bond the nanomesh **95** to the first conductor **110**. More generally, such bonding also could include soldering, sintering, alloying, or forming a conductive adhesive bond. As the semiconductive CNTs are much less likely to respond (align and move) to the applied fields, generally most (or all) of the semiconductive CNTs will remain dispersed and free in the ionic liquid, thereby forming free CNTs **130**. In the event additional free CNTs **130** are necessary or desirable, a plurality of the free CNTs **130** (also dispersed in an ionic liquid **140**) may be deposited over the fixed CNTs **120A**, step **635**, followed by deposition or other attachment of the semipermeable membrane **115**, step **640**. An additional, second plurality of free CNTs **130** (also dispersed in an ionic liquid **140**) may be deposited over the semipermeable membrane **115** (depending on whether the capacitor **700** will be formed by folding the substrate **105**, **105A** as discussed above), step **645**, followed by deposition of a second (or first) electrode **155** (or **150**), formed as described above for a first (or second) electrode **150** (**155**), such as by folding, lamination, or other placement step **650**. Electric leads **15**, **25** are attached to the first conductor **110** (or conductive substrate **105A**) of each electrode **150**, **155**, step **655**, and the device is sealed (sealant **35**), step **660**, forming a capacitor **700**, and the method may end, step **665**. Not separately illustrated, there may be additional curing or sintering steps prior to deposition of additional layers, such as curing or sintering of the nanomesh **95** prior to deposition of the conductive or ballistic CNTs (and semiconductive CNTs).

[0104] In addition, while conductive or ballistic CNTs and semiconductive CNTs are typically produced together within a batch, there are additional ways to enrich or concentrate the

percentage of conductive or ballistic CNTs and/or preferentially separate out the conductive or ballistic CNTs, such as by using surfactants which differentially adsorb on CNTs with different chiralities. For example, metallic (conductive or ballistic) CNTs may be better dispersed with ionic surfactants, while semiconductive CNTs may be better dispersed with non-ionic surfactants such as polymers or DNA. The mixture of CNTs deposited over the nanomesh **95** will then have a higher percentage of conductive or ballistic CNTs, which will tend to increase the capacitance of the capacitor **700**.

[0105] A first way to enrich the mixture of CNTs with metallic (conductive or ballistic) CNTs is to disperse CNTs with polymers such as poly(N-decyl-2,7-carbazole) [2] and poly[9,9-dioctylfluorenyl-2,7-diyl], such as with sonication, and use a centrifuge for separating dispersed and non-dispersed CNTs. The precipitate will be enriched with metallic CNTs. This action can be repeated several times. Then the precipitation will be dispersed with a surfactant suitable for an application. A second way is to consider two phase immiscible system (like water/oil). When an ionic surfactant is dissolved in one phase and non-ionic surfactant is dissolved in another phase, metallic and non-metallic CNTs will have tendency to accumulate in different phases, with this process being repeated several times to generate the metallic CNTs enriched phase.

[0106] It should also be noted that the fixed CNTs **120**, **120A** will generally be placed and secured with irregular, and to some degree random, spacing over the substrate **105A** or first conductor **110**. Such varied and irregular spacing between the fixed CNTs **120**, **120A** is illustrated in FIGS. **2**, **5-7**, and **14** for example. Various fabrication techniques, however, as they become more refined empirically, will tend to limit such spacing irregularity to within a predetermined variance. This is in sharp contrast to the alignment of CNTs in the prior art, which generally have a much more regular and predetermined spacing between and among the CNTs as they are fabricated directly on the electrodes or transferred directly from a silicon growth wafer.

[0107] In addition, while illustrated as coupled generally entirely across a first conductor **110** or conductive substrate **105A**, it should also be noted that the fixed CNTs **120**, **120A** may be coupled in any desired pattern, within such predetermined variance. For example, the fixed CNTs **120**, **120A** may be patterned into spaced apart hexagonal areas, with "streets" of conductor between them, for example and without limitation. Such patterning may be effective in adjusting the overall resistance of an exemplary capacitor **100**, **200**, **300**, **400**, **500**, **600**, **700**.

[0108] FIG. **16** is a block diagram illustrating an exemplary first supercapacitor system **405** embodiment. As illustrated, exemplary capacitors **100**, **200**, **300**, **400**, **500**, **600**, **700** may be utilized as one or more banks or arrays of capacitors to store energy from one or more photovoltaic panels **410**, with any given capacitor **100**, **200**, **300**, **400**, **500**, **600**, **700** selected using selector or switch **415** (which may also provide fault isolation, for example). Discharge and isolation control (**420**) may be provided, with power or energy from the capacitors **100**, **200**, **300**, **400**, **500**, **600**, **700** provided to a power aggregator (**430**) for providing current or voltage output, and under the control of a power bank controller **425**, as illustrated. Not separately illustrated, various sensors (illustrated in FIG. **17**) are typically provided for use in providing feedback of various voltage and current levels to the power bank controller

**425**. The controller **425** (and controller **525**, below) typically implement or control interfaces such as a user interface, a data interface, isolation control, dynamic demand control, instrumentation and sensing, various safety matters, etc.

[0109] FIG. **17** is a block diagram illustrating an exemplary second supercapacitor system **505** embodiment. As illustrated, exemplary capacitors **100**, **200**, **300**, **400**, **500**, **600**, **700** may be utilized as one or more banks or arrays of capacitors to store energy and provide power to a utility, home or business, for example. Current from one or more banks or arrays of capacitors **100**, **200**, **300**, **400**, **500**, **600**, **700**, subject to surge and transient protection (**510**) and load control (**515**) is provided to one or more inverters **520**, **530** to generate AC power, also under the control of a controller **525** (with feedback provided through one or more sensors **535**, such as a high impedance sampling network).

[0110] In summary, the resulting exemplary capacitor **100**, **200**, **300**, **400**, **500**, **600**, **700** embodiments have a structure different from the structures of prior art capacitors, a different fabrication method, and different compositions of matter, with the following nine new and novel features provided as summary highlights. First, the exemplary capacitor **100**, **200**, **300**, **400**, **500**, **600**, **700** embodiments have an additional layer, namely, the free CNTs **130** which are translationally and/or rotationally moveable in an ionic liquid **140**. Second, the exemplary capacitor **200**, **300**, **400**, **500** embodiments have a secondary support structure **170**, **170A**, **170B**, **170C** for the fixed CNTs **120**, which provides a second support to the fixed CNTs **120** at a second location which is separate and spaced apart from a first support location, such as the substrate, and which is not comprised of the fixed CNTs **120** themselves (i.e., the secondary support structure **170**, **170A**, **170B** is in addition to the fixed CNTs **120**). Third, the fixed CNTs **120** and the free CNTs **130** are uncapped at least at one end, and have an interior diameter matched to be slightly greater than the ion size of the selected ionic liquid **140**. Fourth, the fixed CNTs **120** have not been grown on an electrode or transferred directly from a growth plate, but have been dispersed as CNT-magnetic catalyst nanoparticle structures **175** in an ionic liquid **140** and fifth, deposited with an irregular spacing over a first conductor **110** or conductive substrate **105A**. Sixth, the CNT-magnetic catalyst nanoparticle structures **175** are aligned and moved by a magnetic field to couple the magnetic catalyst nanoparticles **125** to the first conductor **110** or conductive substrate **105A**. Seventh, the CNT-magnetic catalyst nanoparticle structures **175** in an ionic liquid **140** comprise a new and novel composition of matter. Eighth, a novel conductive nanomesh comprised of deposited nanorods is utilized in exemplary embodiments for coupling CNTs to form fixed CNTs **120A**. Ninth, an exemplary capacitor **100**, **200**, **300**, **400**, **500**, **600**, **700** provides greater energy density (or specific energy) than a traditional capacitor, and includes a superposition of energy contributions from multiple sources (e.g., ion movement to and from the exterior of the fixed CNTs **120** and the free CNTs **130** ( $\tau_1$ ), ion movement into and out of the interior of the fixed CNTs **120** and/or the free CNTs **130** ( $\tau_2$ ), and delayed ion movement due to the translational and/or rotational movement of the free CNTs **130** ( $\tau_3$ )), yielding a device which also exhibits characteristics of a traditional battery while still having the comparatively higher specific power (or power density) and longer cycle life of a traditional capacitor.

[0111] Although the invention has been described with respect to specific embodiments thereof, these embodiments

are merely illustrative and not restrictive of the invention. In the description herein, numerous specific details are provided, such as examples of electronic components, electronic and structural connections, materials, and structural variations, to provide a thorough understanding of embodiments of the present invention. One skilled in the relevant art will recognize, however, that an embodiment of the invention can be practiced without one or more of the specific details, or with other apparatus, systems, assemblies, components, materials, parts, etc. In other instances, well-known structures, materials, or operations are not specifically shown or described in detail to avoid obscuring aspects of embodiments of the present invention. One having skill in the art will further recognize that additional or equivalent method steps may be utilized, or may be combined with other steps, or may be performed in different orders, any and all of which are within the scope of the claimed invention. In addition, the various Figures are not drawn to scale and should not be regarded as limiting.

**[0112]** Reference throughout this specification to “one embodiment”, “an embodiment”, or a specific “embodiment” means that a particular feature, structure, or characteristic described in connection with the embodiment is included in at least one embodiment and not necessarily in all embodiments, and further, are not necessarily referring to the same embodiment. Furthermore, the particular features, structures, or characteristics of any specific embodiment may be combined in any suitable manner and in any suitable combination with one or more other embodiments, including the use of selected features without corresponding use of other features. In addition, many modifications may be made to adapt a particular application, situation or material to the essential scope and spirit of the present invention. It is to be understood that other variations and modifications of the embodiments of the present invention described and illustrated herein are possible in light of the teachings herein and are to be considered part of the spirit and scope of the present invention.

**[0113]** It will also be appreciated that one or more of the elements depicted in the Figures can also be implemented in a more separate or integrated manner, or even removed or rendered inoperable in certain cases, as may be useful in accordance with a particular application. Integrally formed combinations of components are also within the scope of the invention, particularly for embodiments in which a separation or combination of discrete components is unclear or indiscernible. In addition, use of the term “coupled” herein, including in its various forms such as “coupling” or “couplable”, means and includes any direct or indirect electrical, structural or magnetic coupling, connection or attachment, or adaptation or capability for such a direct or indirect electrical, structural or magnetic coupling, connection or attachment, including integrally formed components and components which are coupled via or through another component.

**[0114]** The dimensions and values disclosed herein are not to be understood as being strictly limited to the exact numerical values recited. Instead, unless otherwise specified, each such dimension is intended to mean both the recited value and a functionally equivalent range surrounding that value. For example, a dimension disclosed as “40 mm” is intended to mean “about 40 mm.”

**[0115]** All documents cited in the Detailed Description of the Invention are, in relevant part, incorporated herein by reference; the citation of any document is not to be construed as an admission that it is prior art with respect to the present

invention. To the extent that any meaning or definition of a term in this document conflicts with any meaning or definition of the same term in a document incorporated by reference, the meaning or definition assigned to that term in this document shall govern.

**[0116]** Furthermore, any signal arrows in the drawings/Figures should be considered only exemplary, and not limiting, unless otherwise specifically noted. Combinations of components of steps will also be considered within the scope of the present invention, particularly where the ability to separate or combine is unclear or foreseeable. The disjunctive term “or”, as used herein and throughout the claims that follow, is generally intended to mean “and/or”, having both conjunctive and disjunctive meanings (and is not confined to an “exclusive or” meaning), unless otherwise indicated. As used in the description herein and throughout the claims that follow, “a”, “an”, and “the” include plural references unless the context clearly dictates otherwise. Also as used in the description herein and throughout the claims that follow, the meaning of “in” includes “in” and “on” unless the context clearly dictates otherwise.

**[0117]** The foregoing description of illustrated embodiments of the present invention, including what is described in the summary or in the abstract, is not intended to be exhaustive or to limit the invention to the precise forms disclosed herein. From the foregoing, it will be observed that numerous variations, modifications and substitutions are intended and may be effected without departing from the spirit and scope of the novel concept of the invention. It is to be understood that no limitation with respect to the specific methods and apparatus illustrated herein is intended or should be inferred. It is, of course, intended to cover by the appended claims all such modifications as fall within the scope of the claims.

It is claimed:

1. A capacitor comprising:
  - a first conductor;
  - a first plurality of fixed carbon nanotubes in an ionic liquid, each fixed carbon nanotube comprising a magnetic catalyst nanoparticle coupled to a carbon nanotube and further coupled to the first conductor; and
  - a first plurality of free carbon nanotubes dispersed and moveable in the ionic liquid.
2. The capacitor of claim 1, wherein for each fixed carbon nanotube of the first plurality of fixed carbon nanotubes, the magnetic catalyst nanoparticle coupled to the first conductor supports the carbon nanotube at a first location, and wherein the capacitor further comprises:
  - a support structure coupled to the first conductor and supporting one or more fixed carbon nanotubes of the first plurality of fixed carbon nanotubes at least at one or more second locations separate from and spaced apart from the first location.
3. The capacitor of claim 2, wherein the support structure is separate and distinct from the first plurality of fixed carbon nanotubes.
4. The capacitor of claim 2, wherein the support structure is a nanofiber support structure.
5. The capacitor of claim 4, wherein the nanofiber support structure is formed by electrospinning a polymer, and wherein the polymer is at least one polymer selected from the group consisting of: polypyrrole; polyaniline; polythiophene; polyterthiophene; derivatives of polythiophene and polyterthiophene; poly(3,4-ethylenedioxythiophene) (PEDOT); poly(3-(4-fluorophenyl)thiophene) (MPFT);

poly(3-(3,4-difluorophenyl)thiophene) (MPFT); poly(3-(4-trifluoromethylphenyl)-thiophene) (PTFMPT); poly(1-cyano-2-(2-(3,4-ethylenedioxythienyl))-1-(2-thienyl)vinylene (ThCNVEDT); poly(3-methylthiophene)(PMeT); and mixtures thereof.

**6.** The capacitor of claim **2**, wherein the support structure is a screen and is spaced apart from the first conductor.

**7.** The capacitor of claim **2**, wherein the first conductor is coupled to a substrate or wherein the first conductor is a conductive substrate.

**8.** The capacitor of claim **7**, wherein the support structure is a plurality of elongated extensions or pillars extending from the substrate, or the first conductor, or the conductive substrate.

**9.** The capacitor of claim **7**, wherein the support structure is a plurality of walls or sides of a plurality of cavities of the substrate, or the first conductor, or the conductive substrate.

**10.** The capacitor of claim **1**, wherein for each fixed carbon nanotube of the first plurality of fixed carbon nanotubes, the magnetic catalyst nanoparticle is coupled to the carbon nanotube at a first end of the carbon nanotube.

**11.** The capacitor of claim **10**, wherein each fixed carbon nanotube of the first plurality of fixed carbon nanotubes is open or uncapped at a second end opposite the first end coupled to the magnetic catalyst nanoparticle.

**12.** The capacitor of claim **1**, wherein each carbon nanotube of the first plurality of free carbon nanotubes is open or uncapped at least at one end.

**13.** The capacitor of claim **1**, wherein each fixed carbon nanotube of the first plurality of fixed carbon nanotubes is single-walled and wherein each carbon nanotube of the first plurality of free carbon nanotubes is multi-walled or single-walled.

**14.** The capacitor of claim **1**, wherein each fixed carbon nanotube of the first plurality of fixed carbon nanotubes is substantially perpendicular to the plane of the first conductor.

**15.** The capacitor of claim **1**, wherein each carbon nanotube of the first plurality of fixed carbon nanotubes and each carbon nanotube of the first plurality of free carbon nanotubes has an interior diameter greater than a Helmholtz diameter of an ion of the ionic liquid.

**16.** The capacitor of claim **1**, wherein each carbon nanotube of the first plurality of fixed carbon nanotubes and each carbon nanotube of the first plurality of free carbon nanotubes has an interior diameter between about 0.5 nm and 1.5 nm.

**17.** The capacitor of claim **1**, wherein the ionic liquid is at least one ionic liquid selected from the group consisting of: butyltrimethylammonium bis(trifluoromethylsulfonyl)imide, 1-ethyl-3-methylimidazolium bis(trifluoromethylsulfonyl)imide, 1-methyl-3-propylimidazolium bis(trifluoromethylsulfonyl)imide, 1-hexyl-3-methylimidazolium bis(trifluoromethylsulfonyl)imide, 1-methyl-3-propylimidazolium iodide, 1-ethyl-3-methylimidazolium thiocyanate, 1-methyl-1-propylpiperidinium bis(trifluoromethylsulfonyl)imide, 1-butyl-2-methylpyridinium bis(trifluoromethylsulfonyl)imide, 1-butyl-4-methylpyridinium bis(trifluoromethylsulfonyl)imide, 1-butyl-1-methylpyrrolidinium bis(trifluoromethylsulfonyl)imide, diethylmethylsulfonium bis(trifluoromethylsulfonyl)imide, lithium bis(trifluoromethylsulfonyl)imide, and mixtures thereof.

**18.** The capacitor of claim **1**, wherein the magnetic catalyst nanoparticle is at least one catalyst selected from the group consisting of: cobalt, molybdenum, nickel, iron, ruthenium, mixtures thereof alloys thereof and their compounds.

**19.** The capacitor of claim **1**, wherein at least some of the carbon nanotubes of the first plurality of fixed carbon nanotubes and at least some of the carbon nanotubes of the first plurality of free carbon nanotubes has a chirality of (n, m) where  $n=m$  or where the quotient of m minus n is divided by three  $((m-n)/3)$  is an integer.

**20.** The capacitor of claim **1**, further comprising:  
a semipermeable membrane.

**21.** The capacitor of claim **20**, wherein the semipermeable membrane comprises polytetrafluoroethylene (PTFE).

**22.** The capacitor of claim **20**, wherein the first plurality of free carbon nanotubes are not coupled to the first conductor, are not coupled to the first plurality of fixed carbon nanotubes, and are not coupled to the semipermeable membrane.

**23.** The capacitor of claim **1**, wherein the first plurality of free carbon nanotubes are translationally and rotationally moveable in the ionic liquid.

**24.** The capacitor of claim **1**, wherein the first plurality of fixed carbon nanotubes and the first conductor form a first electrode, and wherein the capacitor further comprises:

a semipermeable membrane between the first electrode and a second electrode, the second electrode comprising:  
a second conductor;

a second plurality of fixed carbon nanotubes in the ionic liquid, each fixed carbon nanotube comprising a magnetic catalyst nanoparticle coupled to a carbon nanotube and further coupled to the second conductor; and  
a second plurality of free carbon nanotubes moveable in the ionic liquid.

**25.** A capacitor comprising:

a first conductor;  
a first conductive nanomesh coupled to the first conductor;  
a first plurality of fixed carbon nanotubes in an ionic liquid and further coupled to the first conductive nanomesh;  
and

a first plurality of free carbon nanotubes dispersed and moveable in the ionic liquid.

**26.** The capacitor of claim **25**, wherein the first conductive nanomesh is metallic.

**27.** The capacitor of claim **26**, wherein the first conductive nanomesh comprises gold or palladium nanorods.

**28.** The capacitor of claim **25**, wherein the first conductive nanomesh comprises metallic nanorods having a diameter of less than about 100 nm and a length between about 200 nm and about 1.0 microns.

**29.** The capacitor of claim **25**, wherein the first conductor is coupled to a substrate or wherein the first conductor is a conductive substrate.

**30.** The capacitor of claim **25**, wherein each fixed carbon nanotube of the first plurality of fixed carbon nanotubes is open or uncapped at least at one end and wherein each carbon nanotube of the first plurality of free carbon nanotubes is open or uncapped at least at one end.

**31.** The capacitor of claim **25**, wherein each fixed carbon nanotube of the first plurality of fixed carbon nanotubes is single-walled.

**32.** The capacitor of claim **25**, wherein each carbon nanotube of the first plurality of free carbon nanotubes is multi-walled or single-walled.

**33.** The capacitor of claim **25**, wherein each carbon nanotube of the first plurality of fixed carbon nanotubes and each carbon nanotube of the first plurality of free carbon nanotubes has an interior diameter greater than a Helmholtz diameter of an ion of the ionic liquid.

**34.** The capacitor of claim **25**, wherein each carbon nanotube of the first plurality of fixed carbon nanotubes and each carbon nanotube of the first plurality of free carbon nanotubes has an interior diameter between about 0.5 nm and 1.5 nm.

**35.** The capacitor of claim **25**, wherein the ionic liquid is at least one ionic liquid selected from the group consisting of: butyltrimethylammonium bis(trifluoromethylsulfonyl)imide, 1-ethyl-3-methylimidazolium bis(trifluoromethylsulfonyl)imide, 1-methyl-3-propylimidazolium bis(trifluoromethylsulfonyl)imide, 1-hexyl-3-methylimidazolium bis(trifluoromethylsulfonyl)imide, 1-methyl-3-propylimidazolium iodide, 1-ethyl-3-methylimidazolium thiocyanate, 1-methyl-1-propylpiperidinium bis(trifluoromethylsulfonyl)imide, 1-butyl-2-methylpyridinium bis(trifluoromethylsulfonyl)imide, 1-butyl-4-methylpyridinium bis(trifluoromethylsulfonyl)imide, 1-butyl-1-methylpyrrolidinium bis(trifluoromethylsulfonyl)imide, diethylmethylsulfonium bis(trifluoromethylsulfonyl)imide, lithium bis(trifluoromethylsulfonyl)imide, and mixtures thereof.

**36.** The capacitor of claim **25**, wherein each fixed carbon nanotube of the first plurality of fixed carbon nanotubes is substantially perpendicular to the plane of the first conductor.

**37.** The capacitor of claim **25**, wherein at least some of the carbon nanotubes of the first plurality of fixed carbon nanotubes are metallic, conductive or ballistic.

**38.** The capacitor of claim **25**, wherein at least some of the carbon nanotubes of the first plurality of fixed carbon nanotubes and at least some of the carbon nanotubes of the first plurality of free carbon nanotubes has a chirality of (n, m) where  $n=m$  or where the quotient of  $m$  minus  $n$  is divided by three  $((m-n)/3)$  is an integer.

**39.** The capacitor of claim **25**, further comprising:  
a semipermeable membrane.

**40.** The capacitor of claim **39**, wherein the semipermeable membrane comprises polytetrafluoroethylene (PTFE).

**41.** The capacitor of claim **40**, wherein the first plurality of free carbon nanotubes are not coupled to the first conductor, are not coupled to the first plurality of fixed carbon nanotubes, and are not coupled to the semipermeable membrane.

**42.** The capacitor of claim **25**, wherein the first plurality of free carbon nanotubes are translationally and rotationally moveable in the ionic liquid.

**43.** The capacitor of claim **25**, wherein the first plurality of fixed carbon nanotubes, the first conductive nanomesh and the first conductor form a first electrode, and wherein the capacitor further comprises:

a semipermeable membrane between the first electrode and a second electrode, the second electrode comprising:

a second conductor;

a second conductive nanomesh coupled to the second conductor;

a second plurality of fixed carbon nanotubes in an ionic liquid and further coupled to the second conductive nanomesh; and

a second plurality of free carbon nanotubes dispersed and moveable in the ionic liquid.

**44.** A capacitor comprising:

a first conductor;

a first plurality of fixed carbon nanotubes in an ionic liquid, each fixed carbon nanotube comprising a magnetic catalyst nanoparticle coupled to a carbon nanotube and further coupled at a first location to the first conductor;

a support structure coupled to the first conductor and supporting one or more fixed carbon nanotubes of the first plurality of fixed carbon nanotubes at least at one or more second locations separate from and spaced apart from the first location; and

a first plurality of free carbon nanotubes dispersed and moveable in the ionic liquid.

**45.** A capacitor comprising:

a first conductor;

a metallic nanomesh coupled to the first conductor, the metallic nanomesh comprising gold or palladium nanorods having a diameter of less than about 100 nm and a length between about 200 nm and about 1.0 microns;

a plurality of fixed carbon nanotubes in an ionic liquid and further coupled to the metallic nanomesh; and

a plurality of free carbon nanotubes dispersed and moveable in the ionic liquid.

\* \* \* \* \*