



(19) **United States**

(12) **Patent Application Publication**  
**Bridges et al.**

(10) **Pub. No.: US 2011/0025556 A1**

(43) **Pub. Date: Feb. 3, 2011**

(54) **CONNECTION LOCATOR IN A POWER AGGREGATION SYSTEM FOR DISTRIBUTED ELECTRIC RESOURCES**

filed on Dec. 11, 2006, provisional application No. 60/915,347, filed on May 1, 2007.

(75) Inventors: **Seth W. Bridges**, Seattle, WA (US);  
**Seth B. Pollack**, Seattle, WA (US);  
**David L. Kaplan**, Seattle, WA (US)

Correspondence Address:  
**Lee & Hayes, PLLC**  
**Suite 500**  
**421 West Riverside Avenue**  
**Spokane, WA 99201 (US)**

(73) Assignee: **GridPoint, Inc.**, Arlington, VA (US)

(21) Appl. No.: **12/826,282**

(22) Filed: **Jun. 29, 2010**

**Related U.S. Application Data**

(63) Continuation of application No. 11/836,747, filed on Aug. 9, 2007, now Pat. No. 7,747,739.

(60) Provisional application No. 60/822,047, filed on Aug. 10, 2006, provisional application No. 60/869,439,

**Publication Classification**

(51) **Int. Cl.**  
**G01S 19/42** (2010.01)  
**G06F 15/16** (2006.01)  
**G01S 3/02** (2006.01)

(52) **U.S. Cl.** ..... **342/357.25**; 709/224; 342/457

(57) **ABSTRACT**

Systems and methods are described for a power aggregation system. In one implementation, a service establishes individual Internet connections to numerous electric resources intermittently connected to the power grid, such as electric vehicles. The Internet connection may be made over the same wire that connects the resource to the power grid. The service optimizes power flows to suit the needs of each resource and each resource owner, while aggregating flows across numerous resources to suit the needs of the power grid. The service can bring vast numbers of electric vehicle batteries online as a new, dynamically aggregated power resource for the power grid. Electric vehicle owners can participate in an electricity trading economy regardless of where they plug into the power grid.

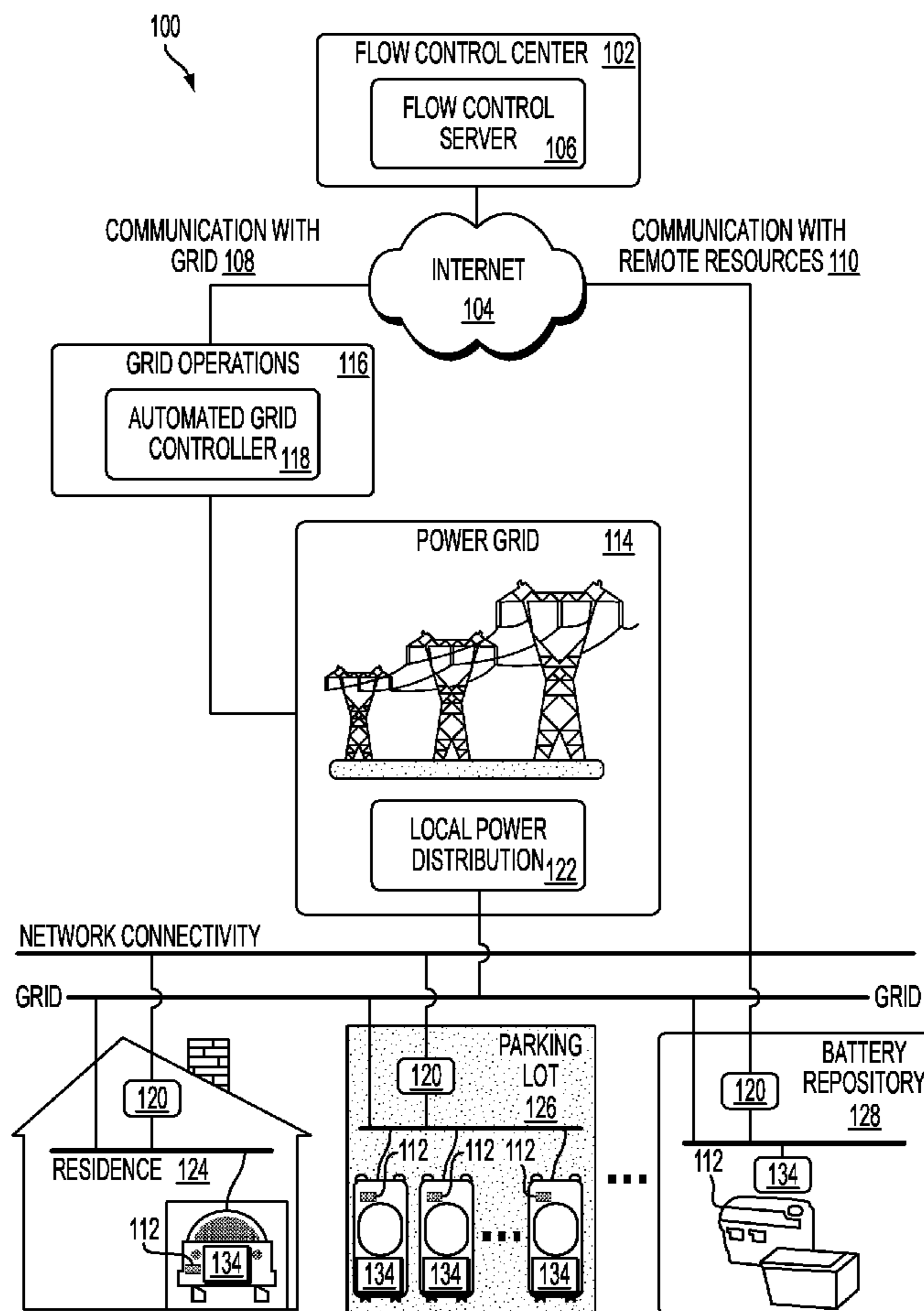

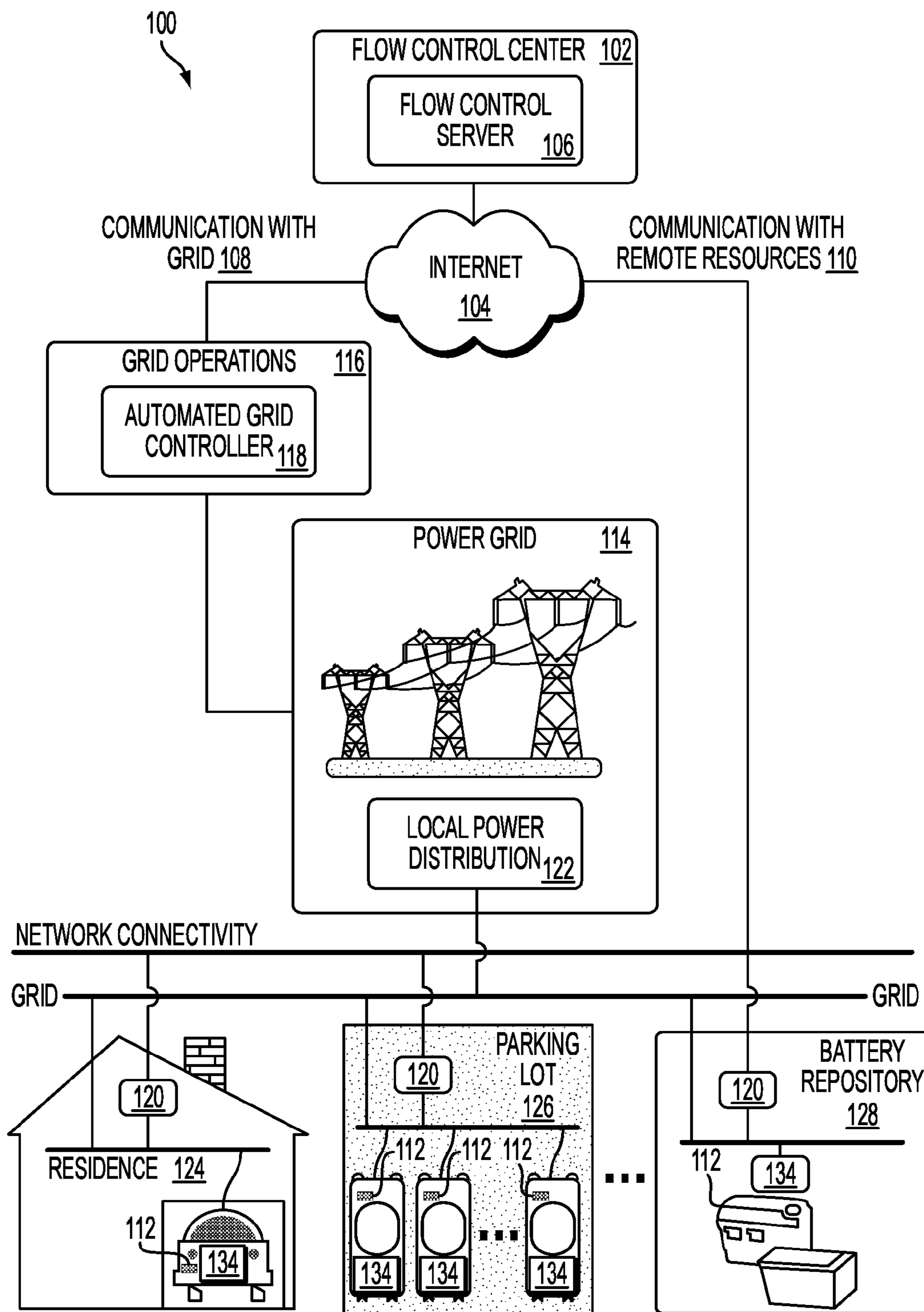

FIG. 1

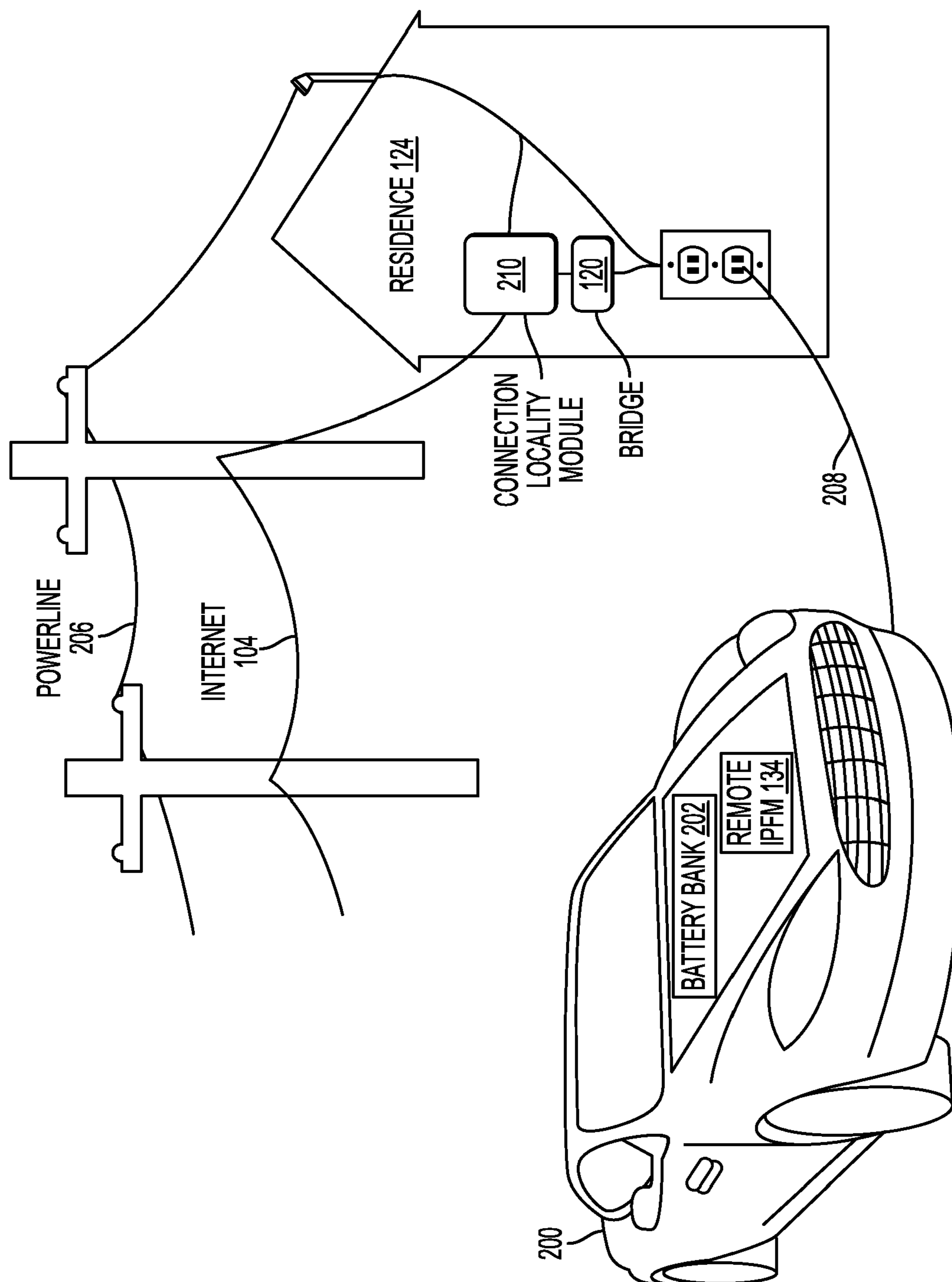

FIG. 2

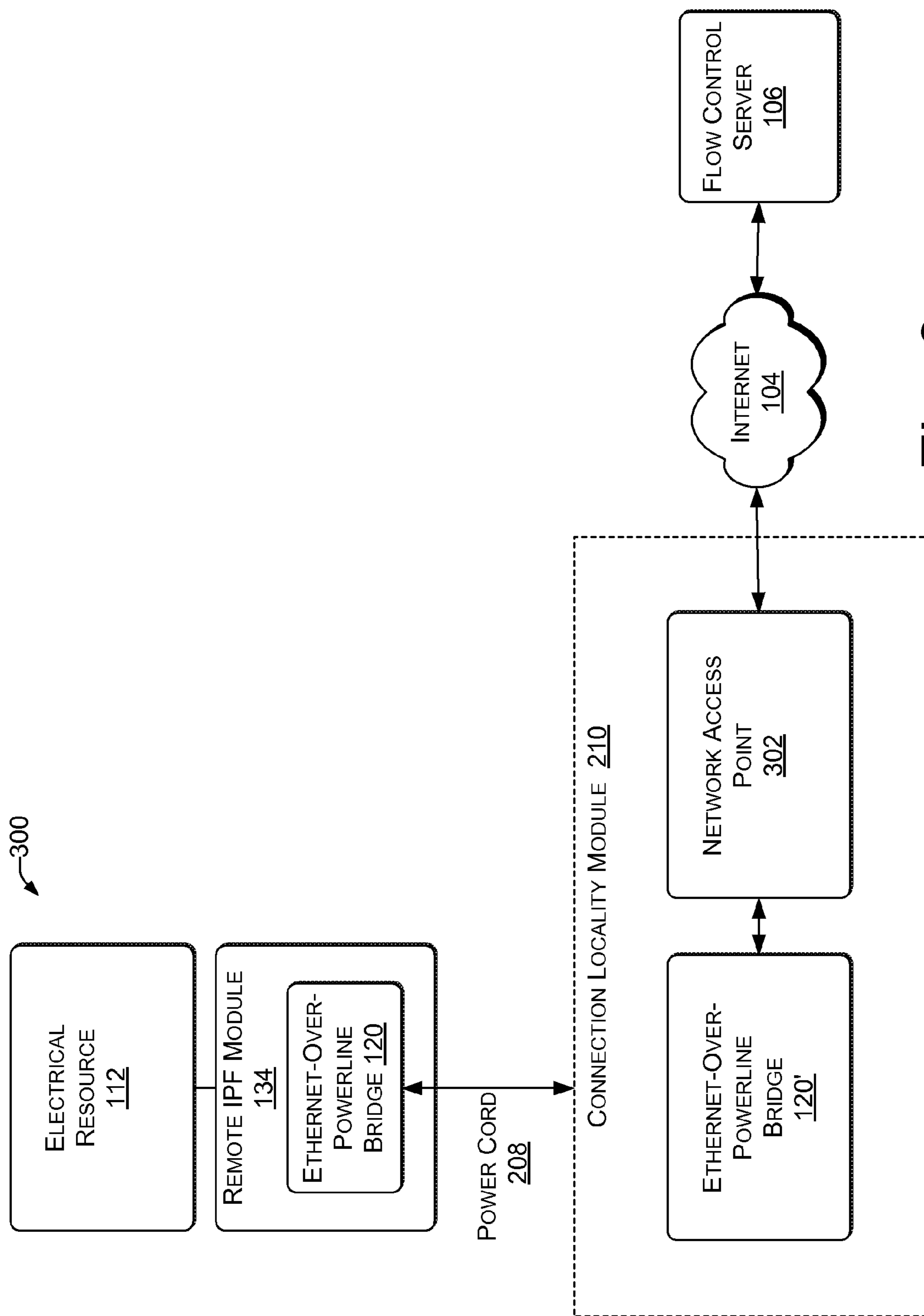

Fig. 3

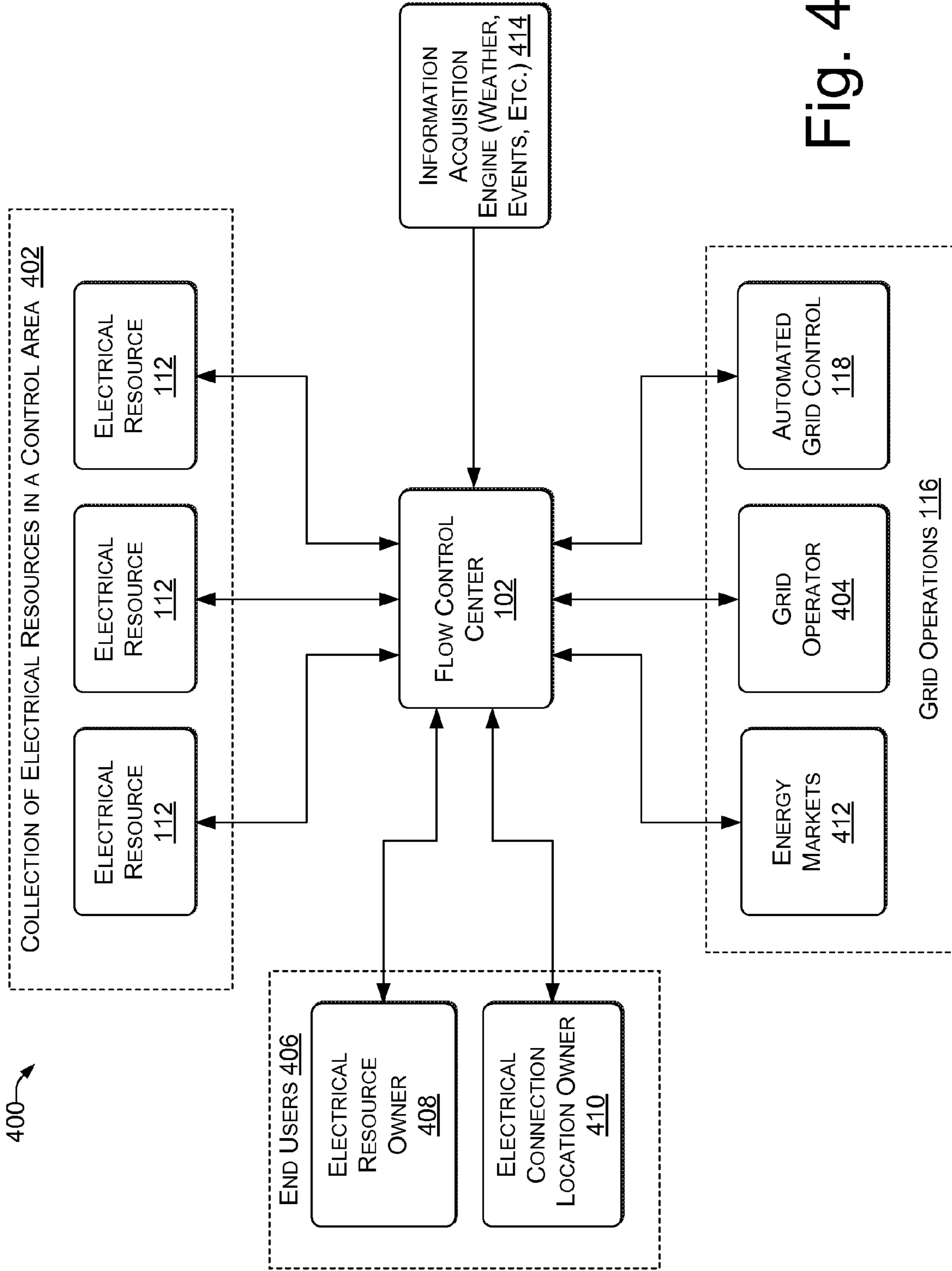

Fig. 4



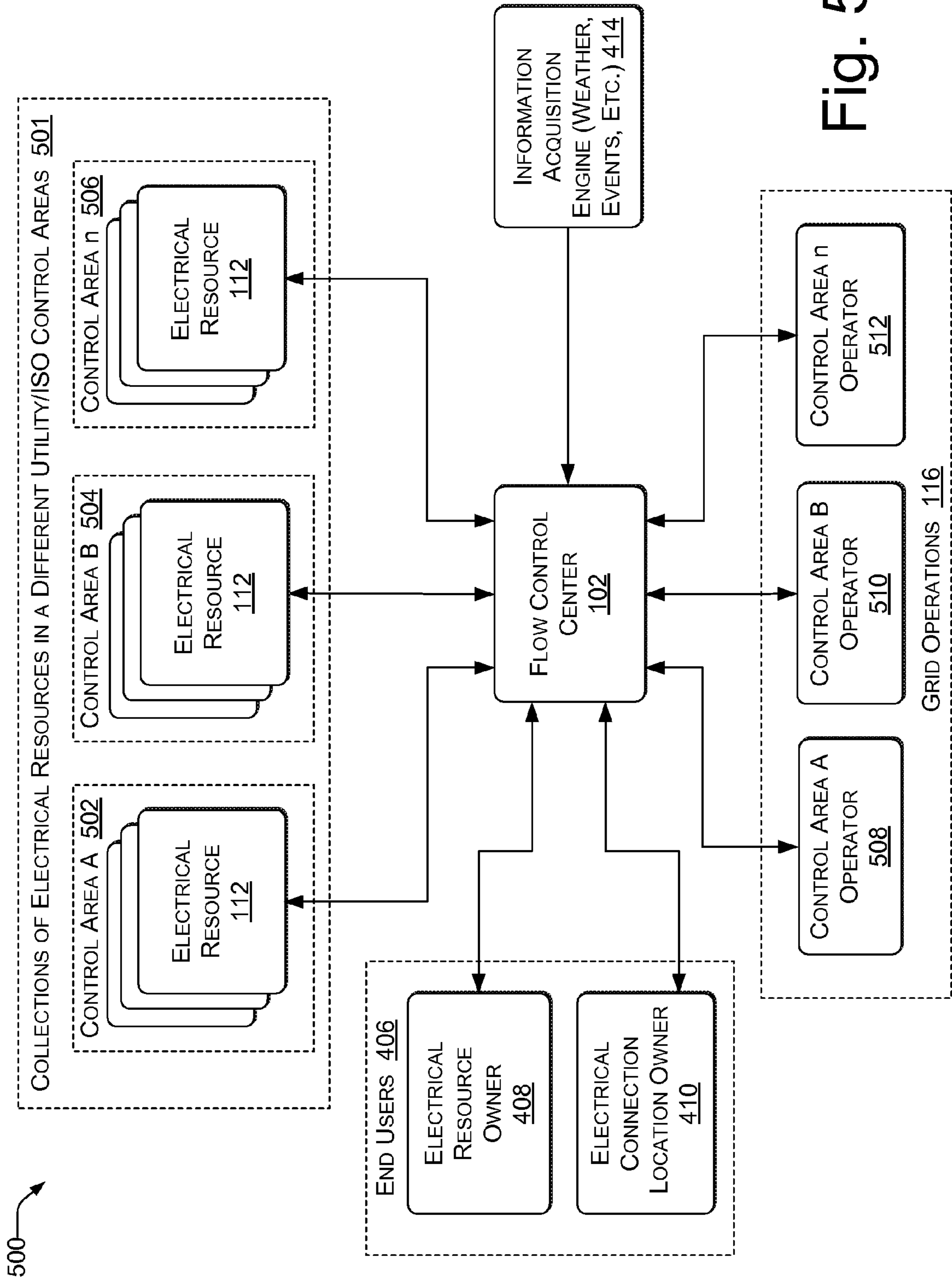

Fig. 5

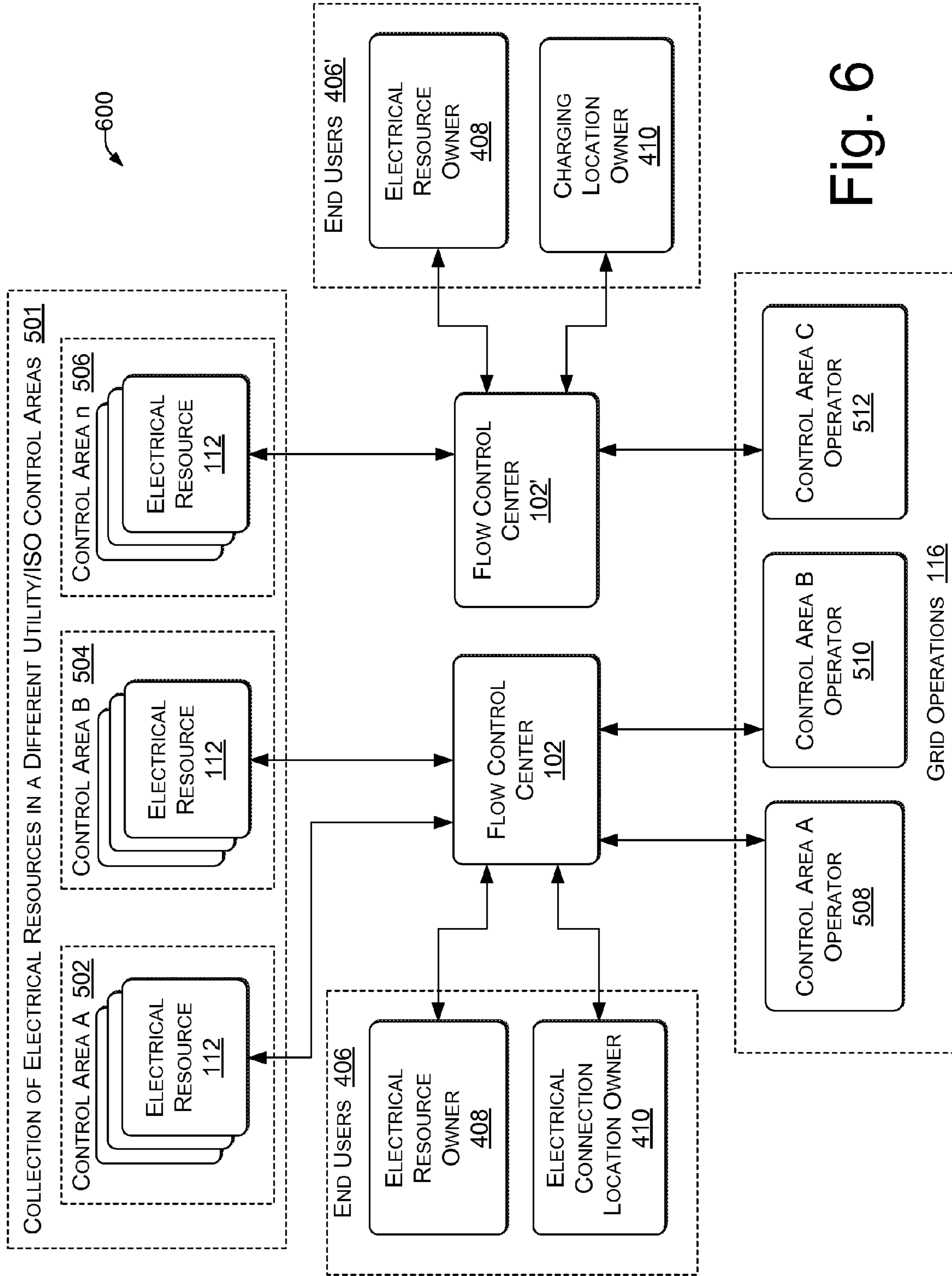

Fig. 6

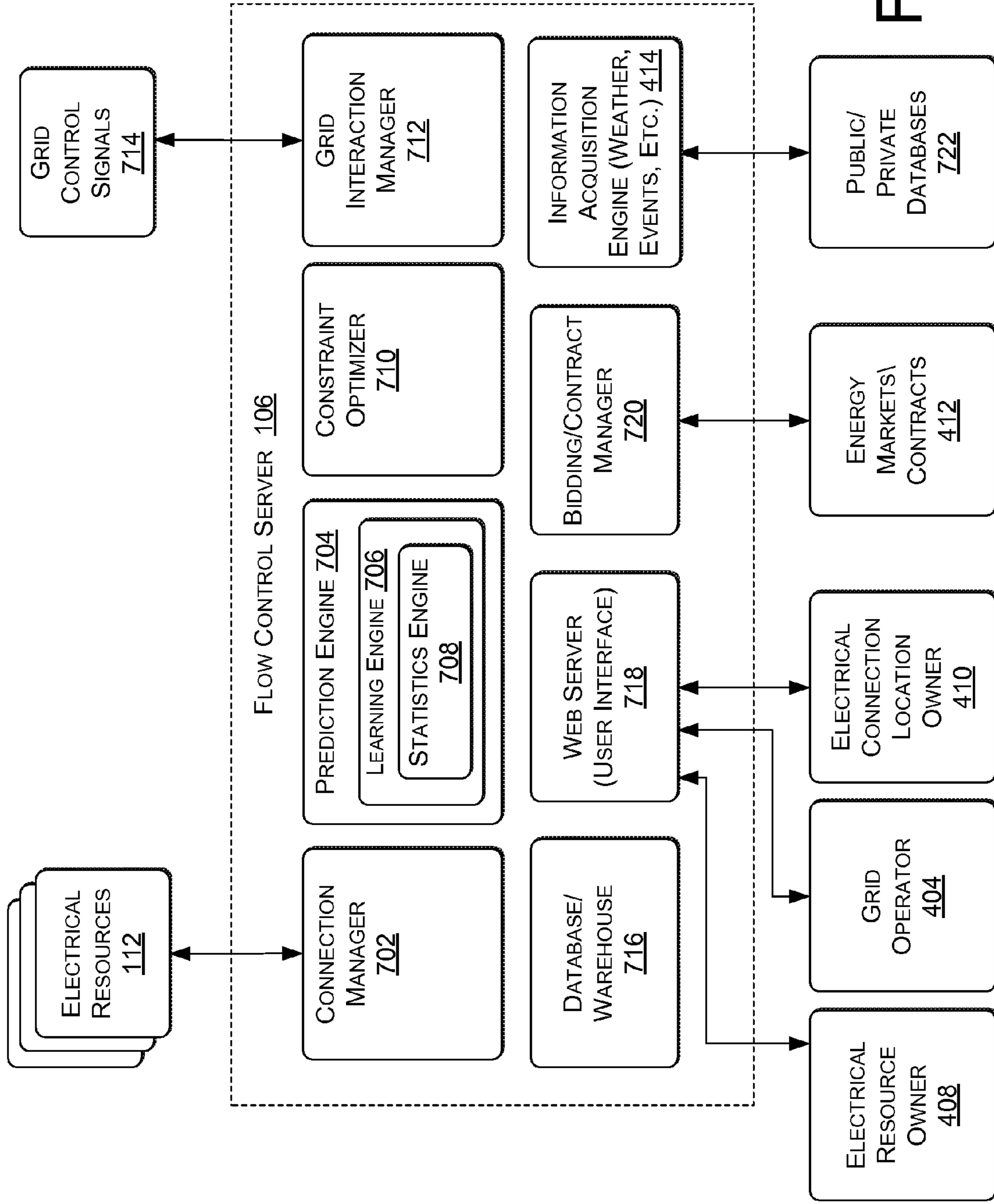

Fig. 7



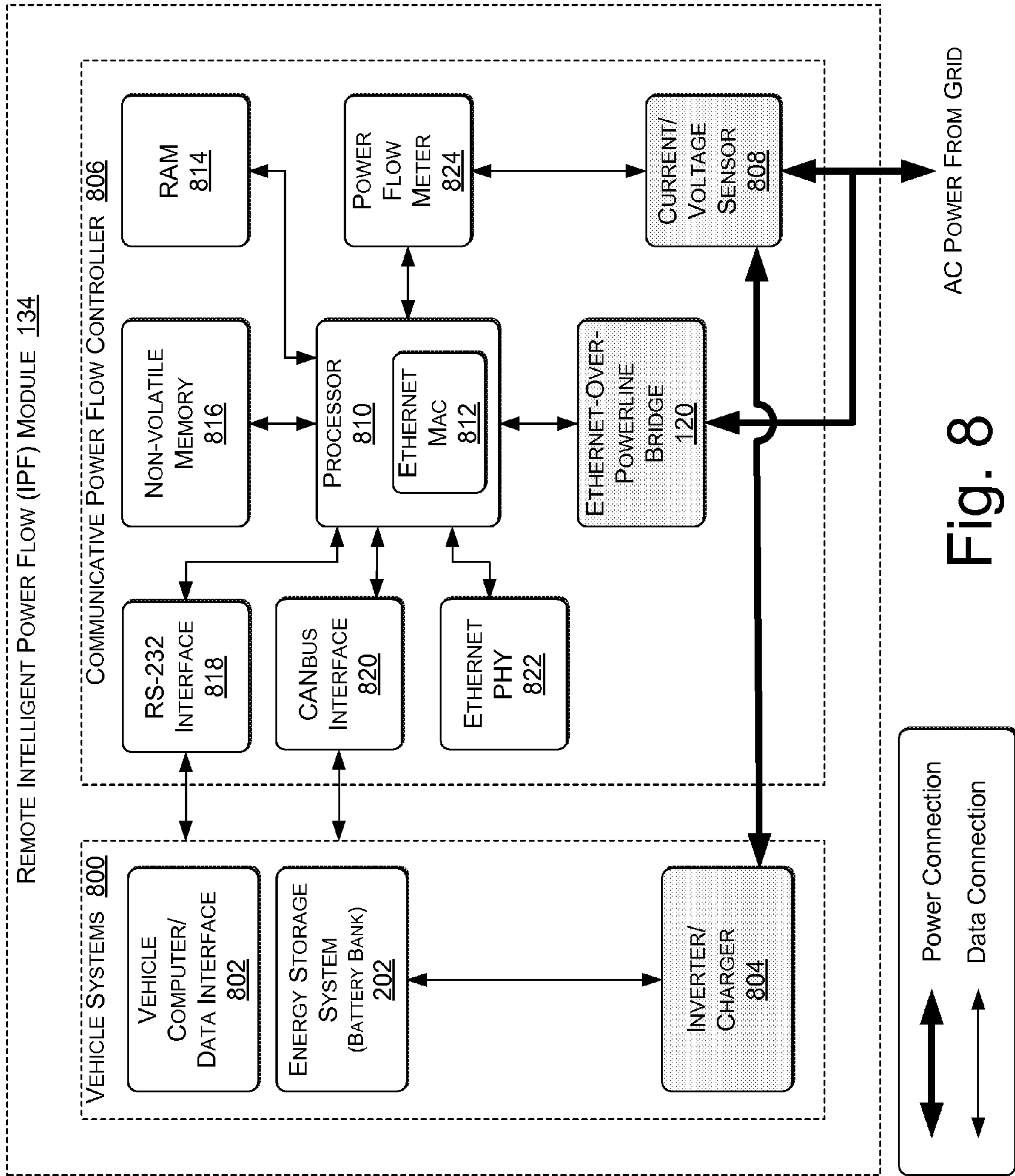

Fig. 8

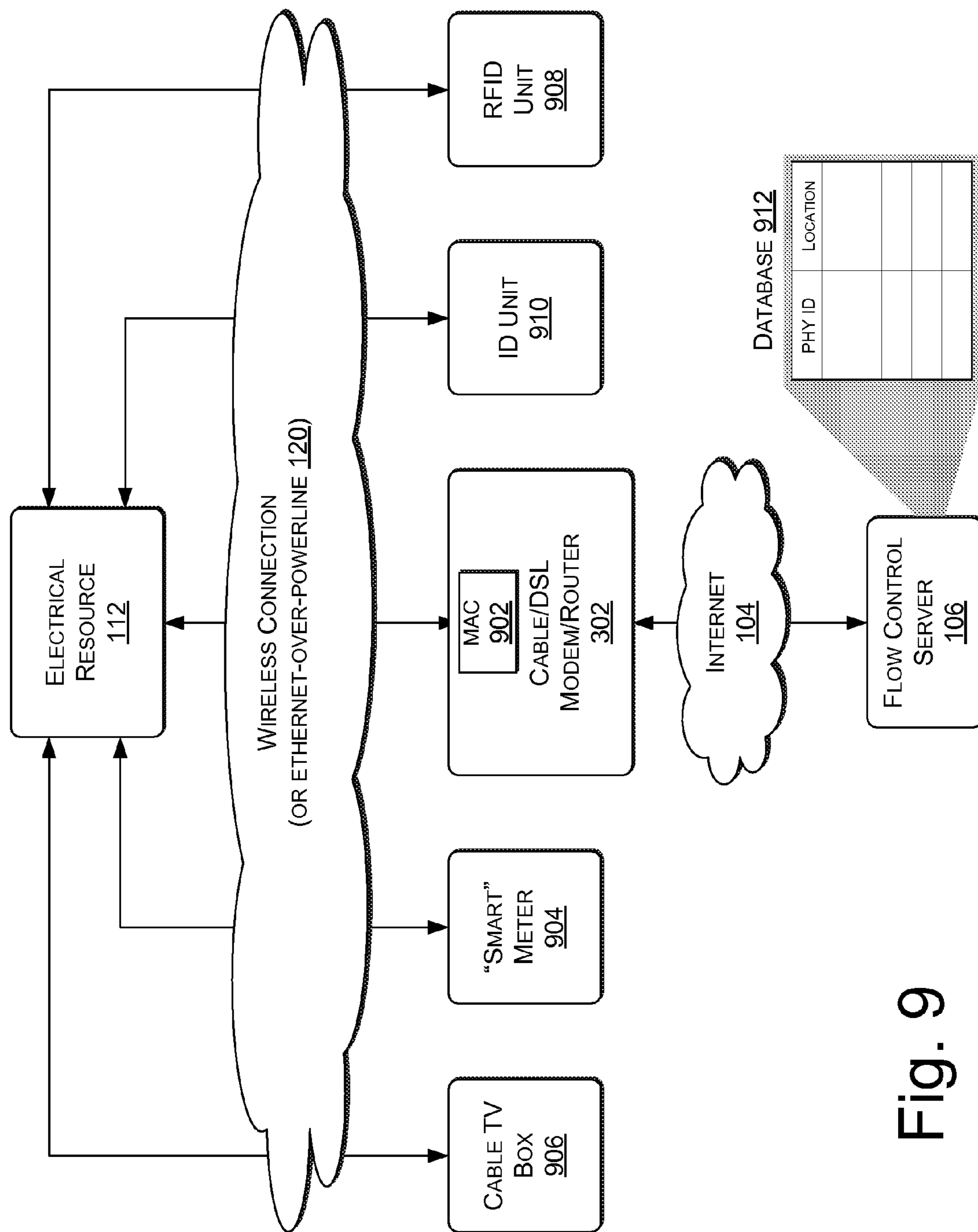

Fig. 9

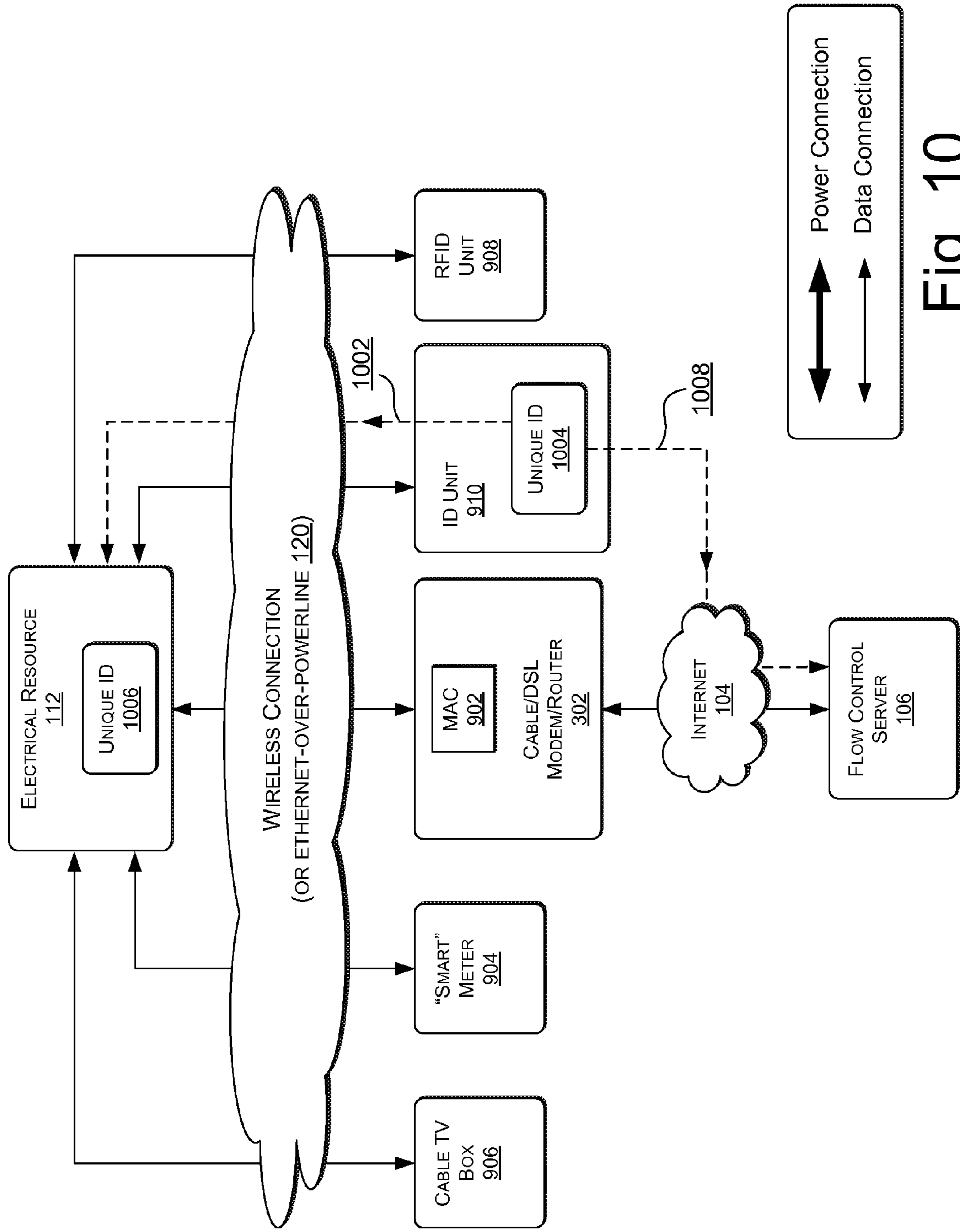

Fig. 10

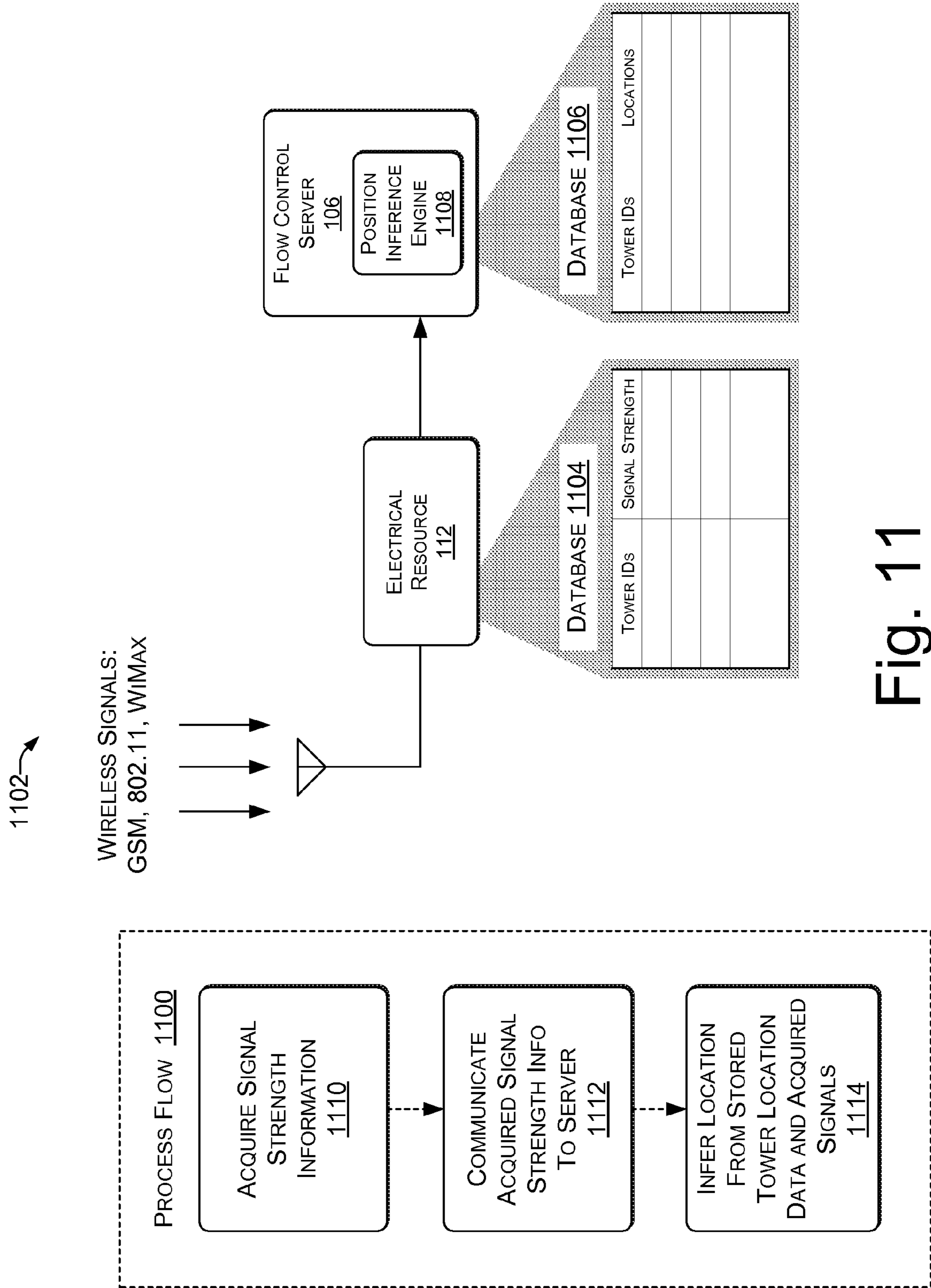

Fig. 11

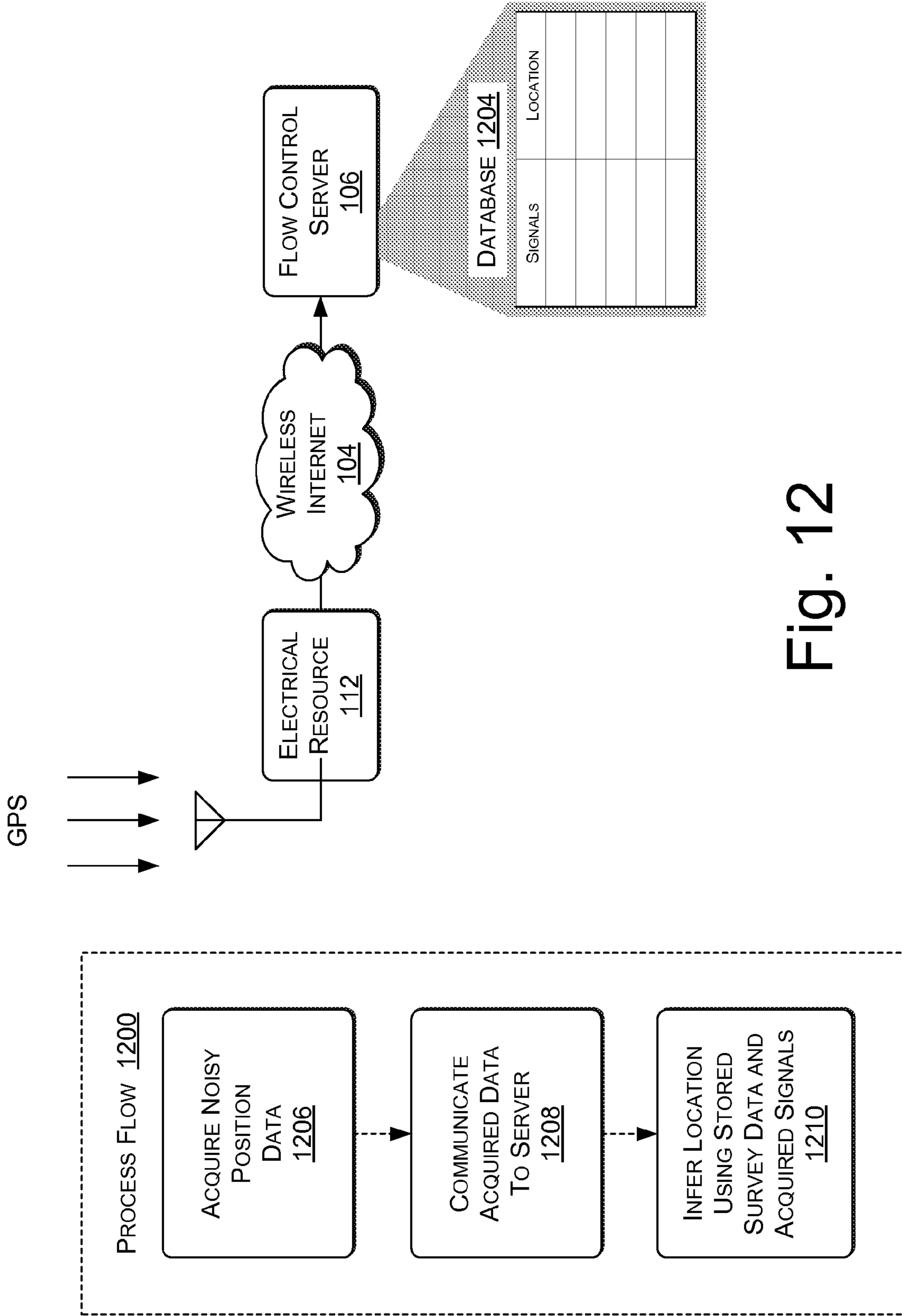

Fig. 12



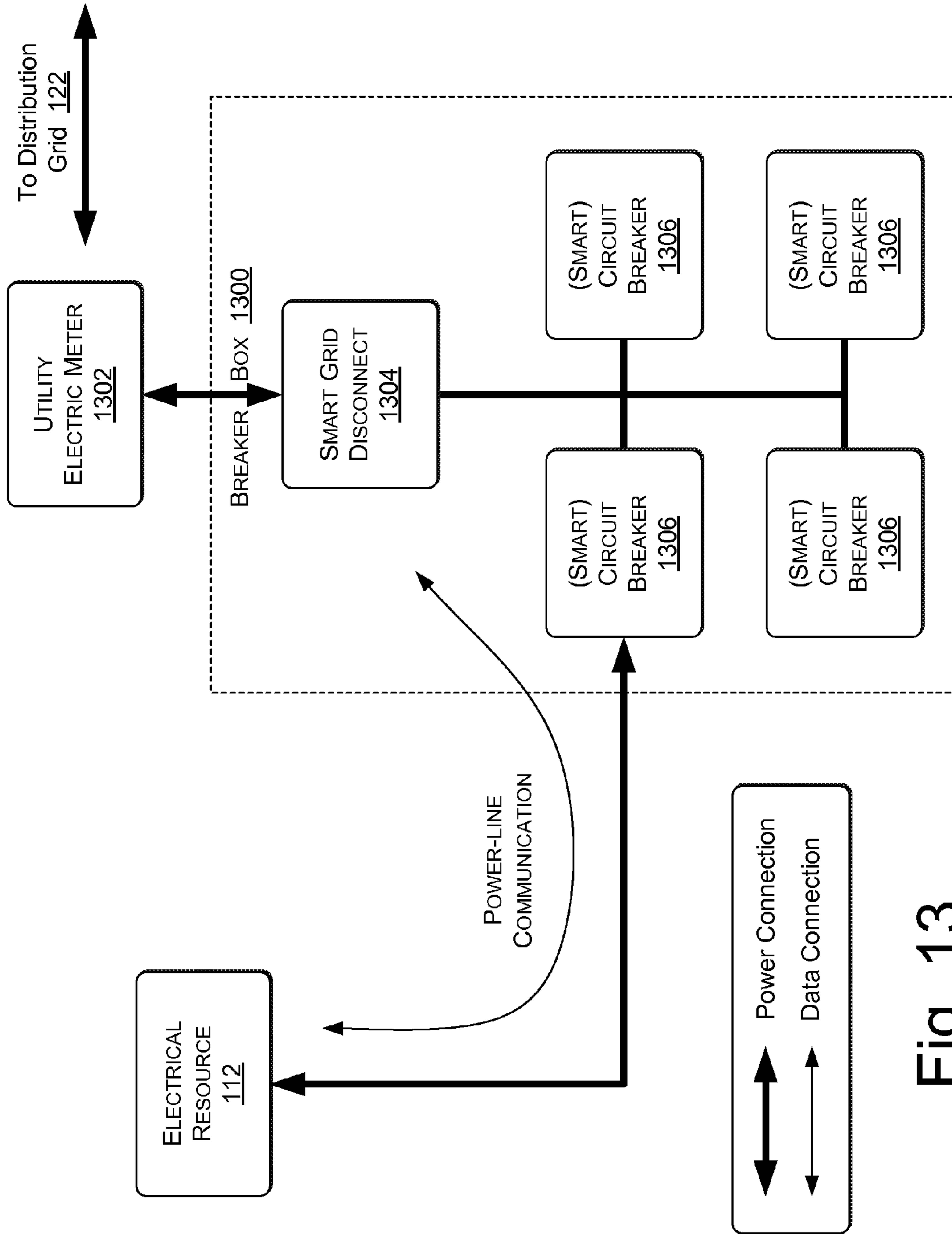

Fig. 13

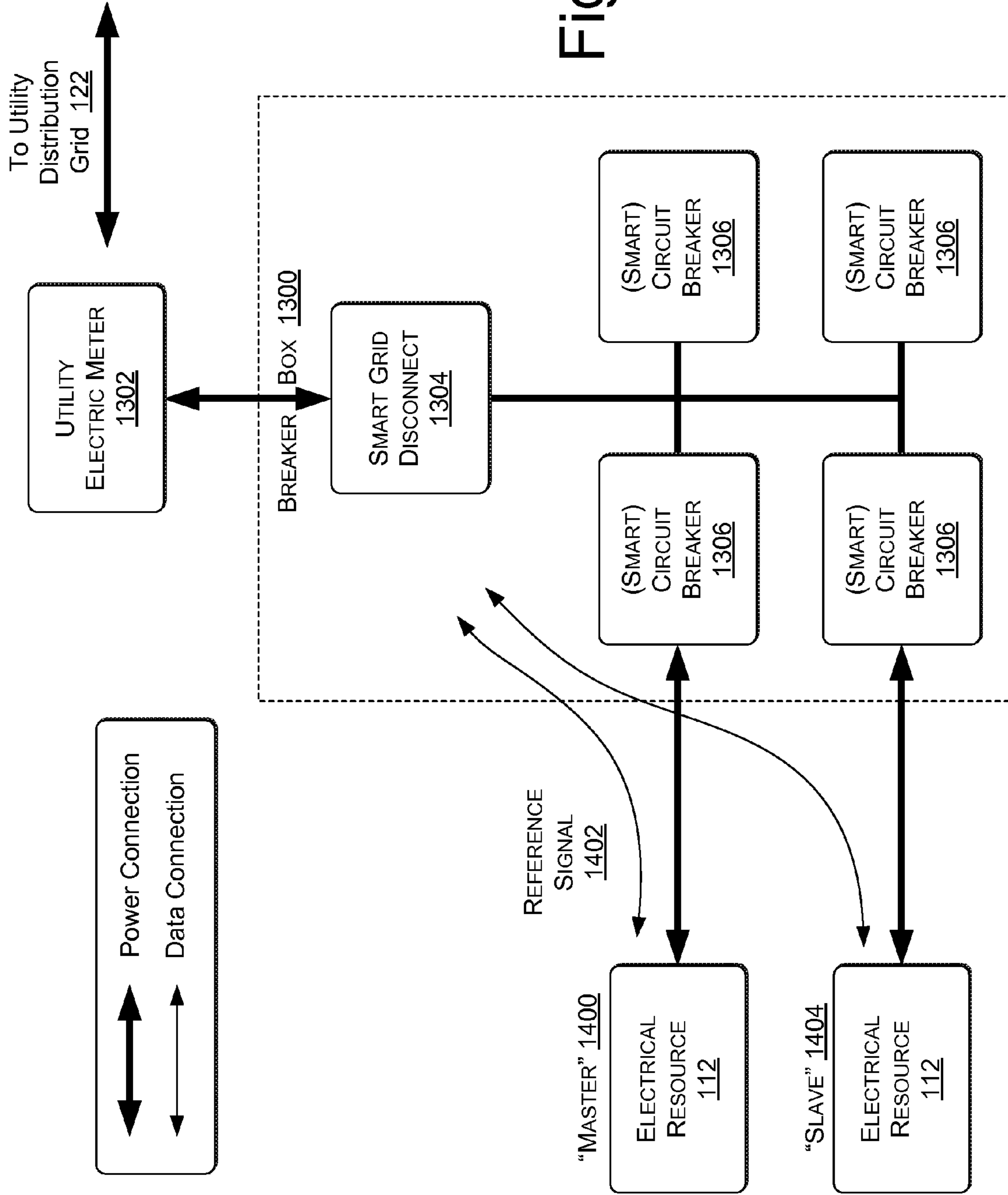

Fig. 14

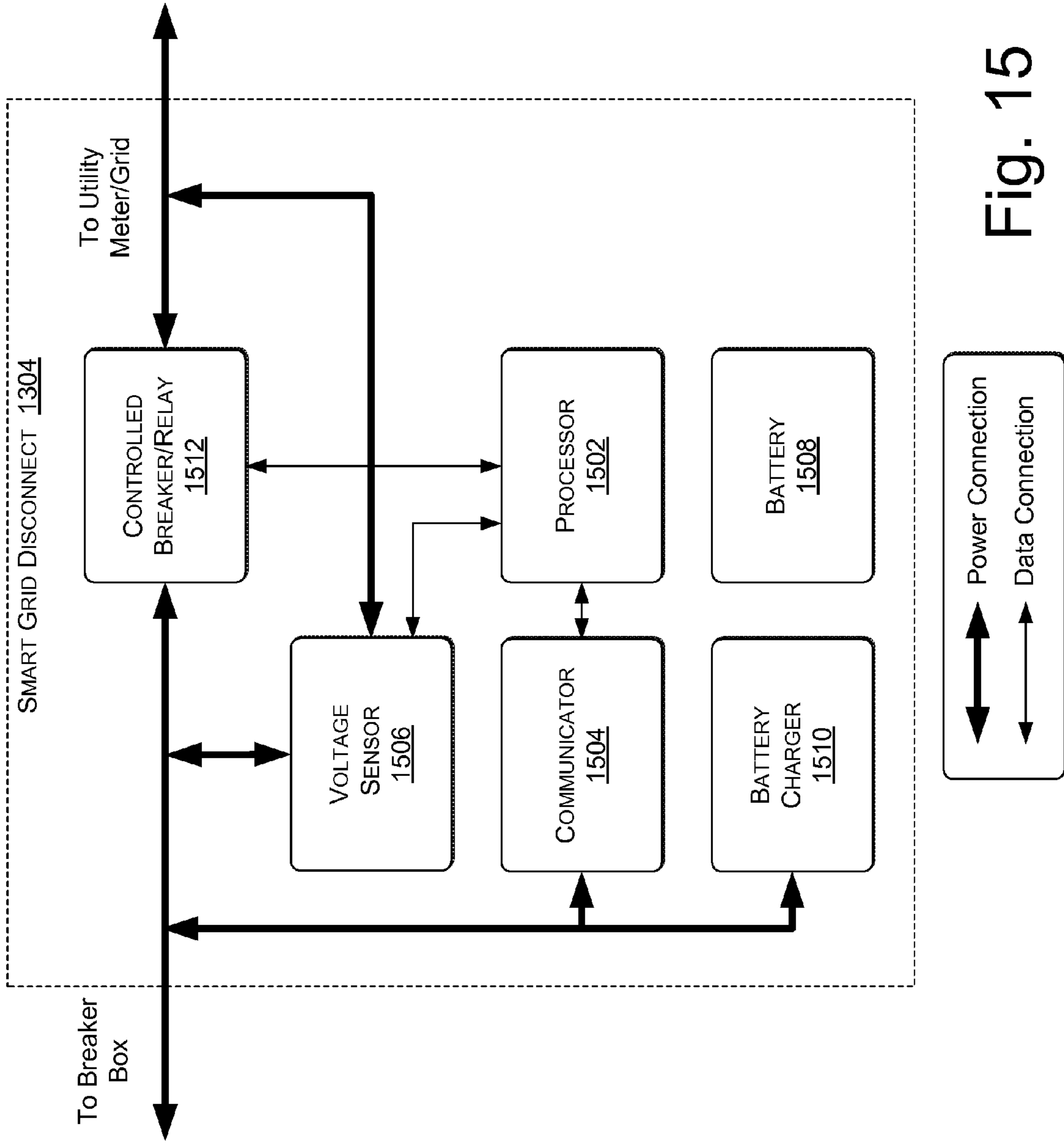

Fig. 15

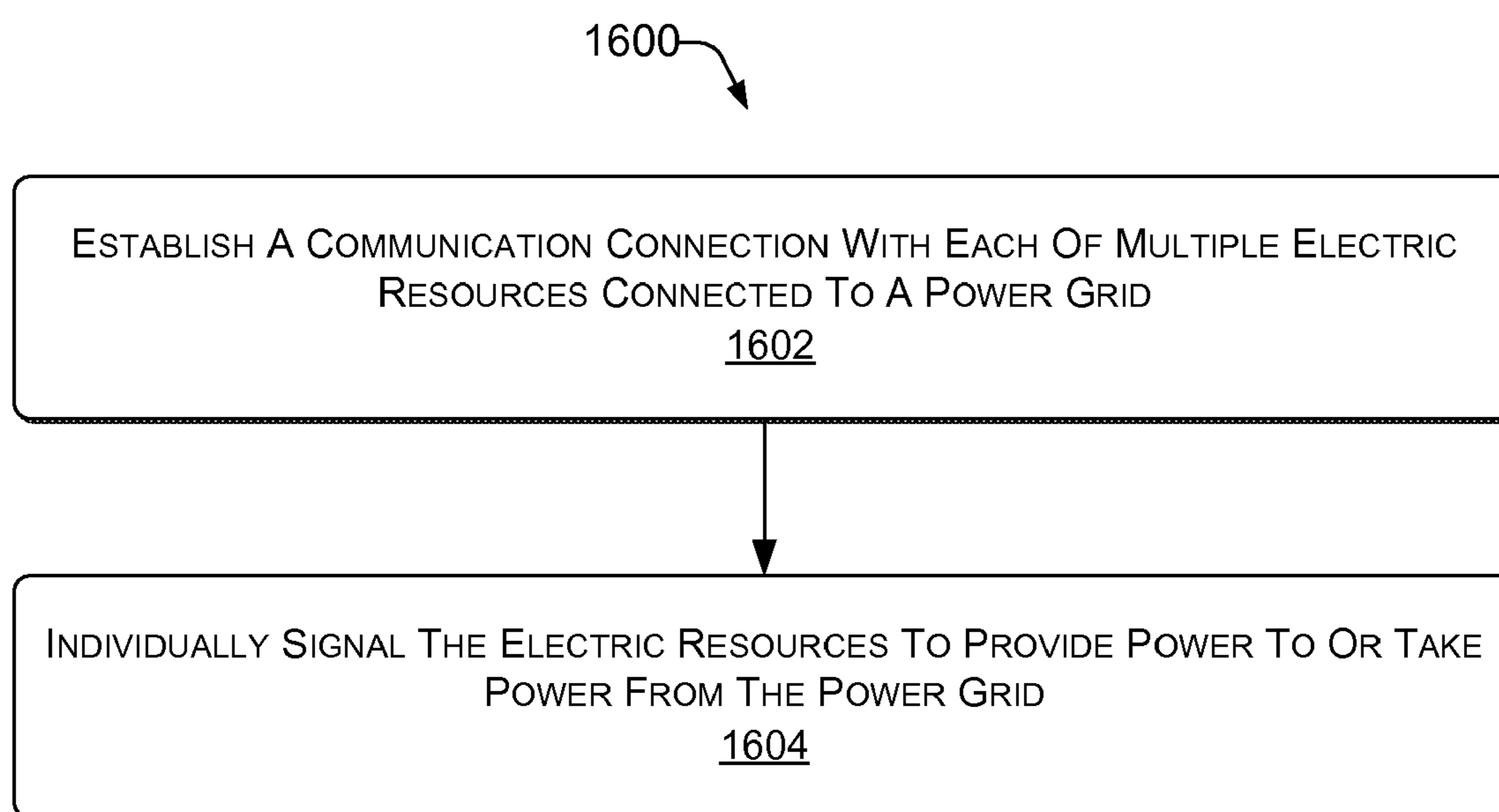

Fig. 16

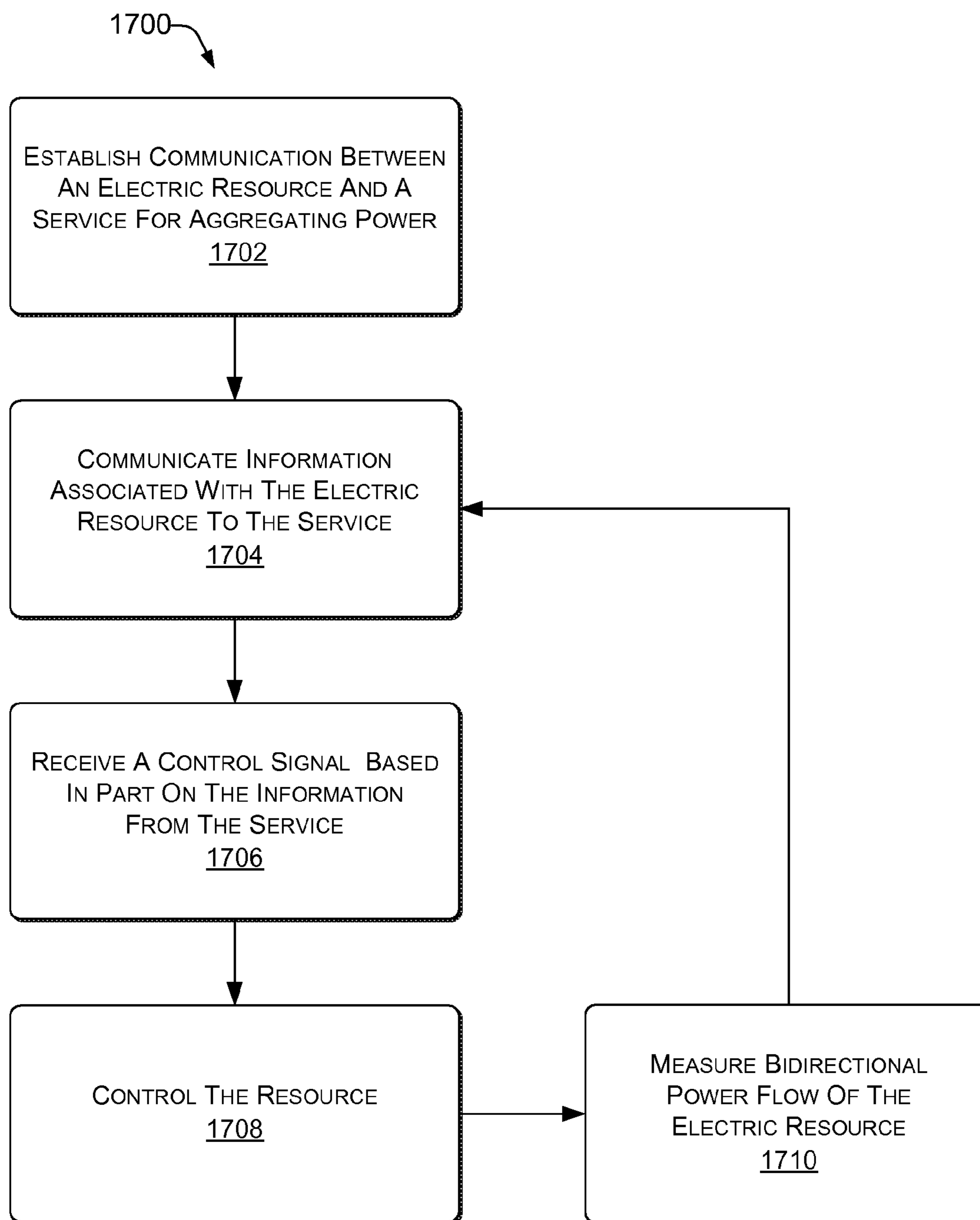

Fig. 17



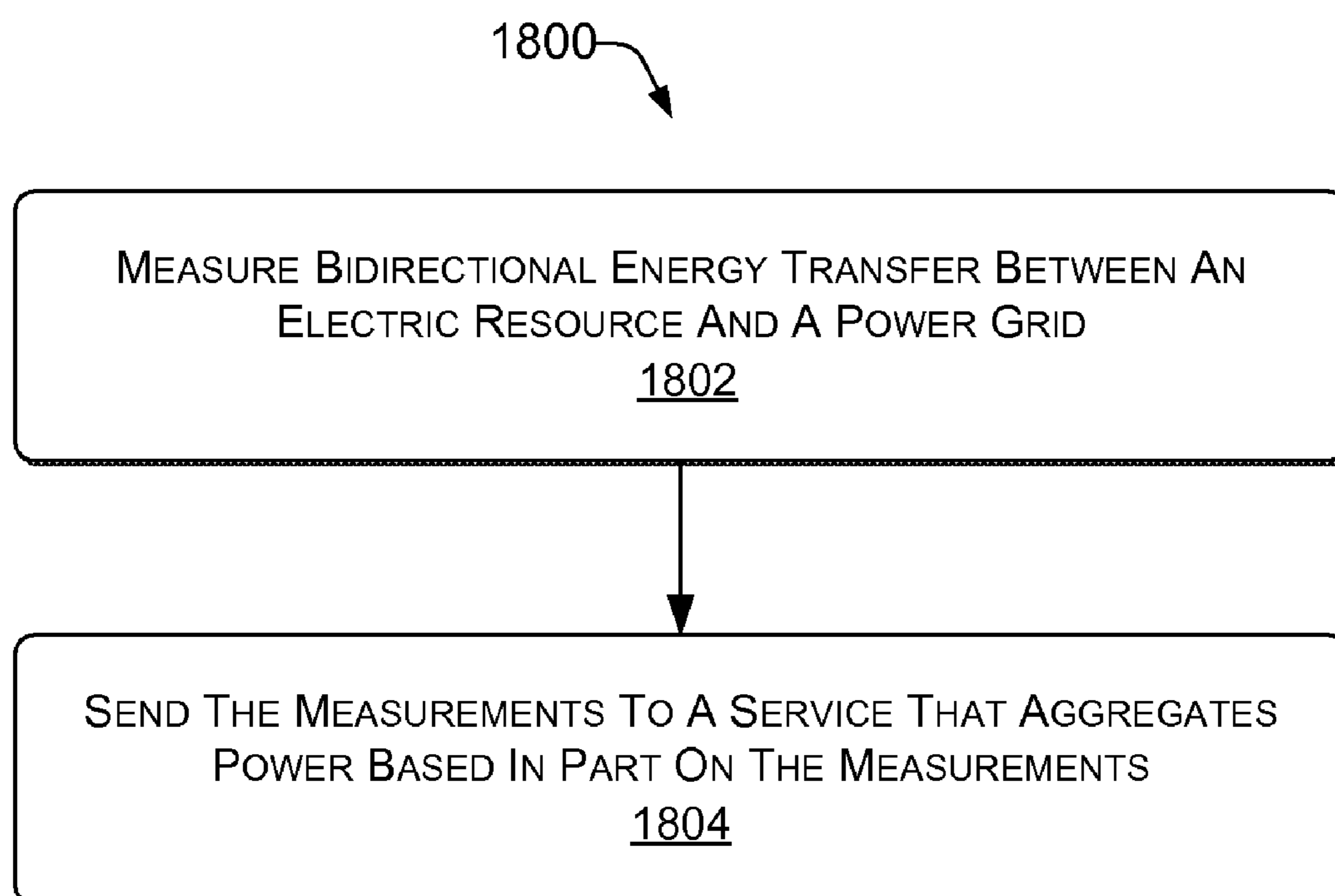

Fig. 18

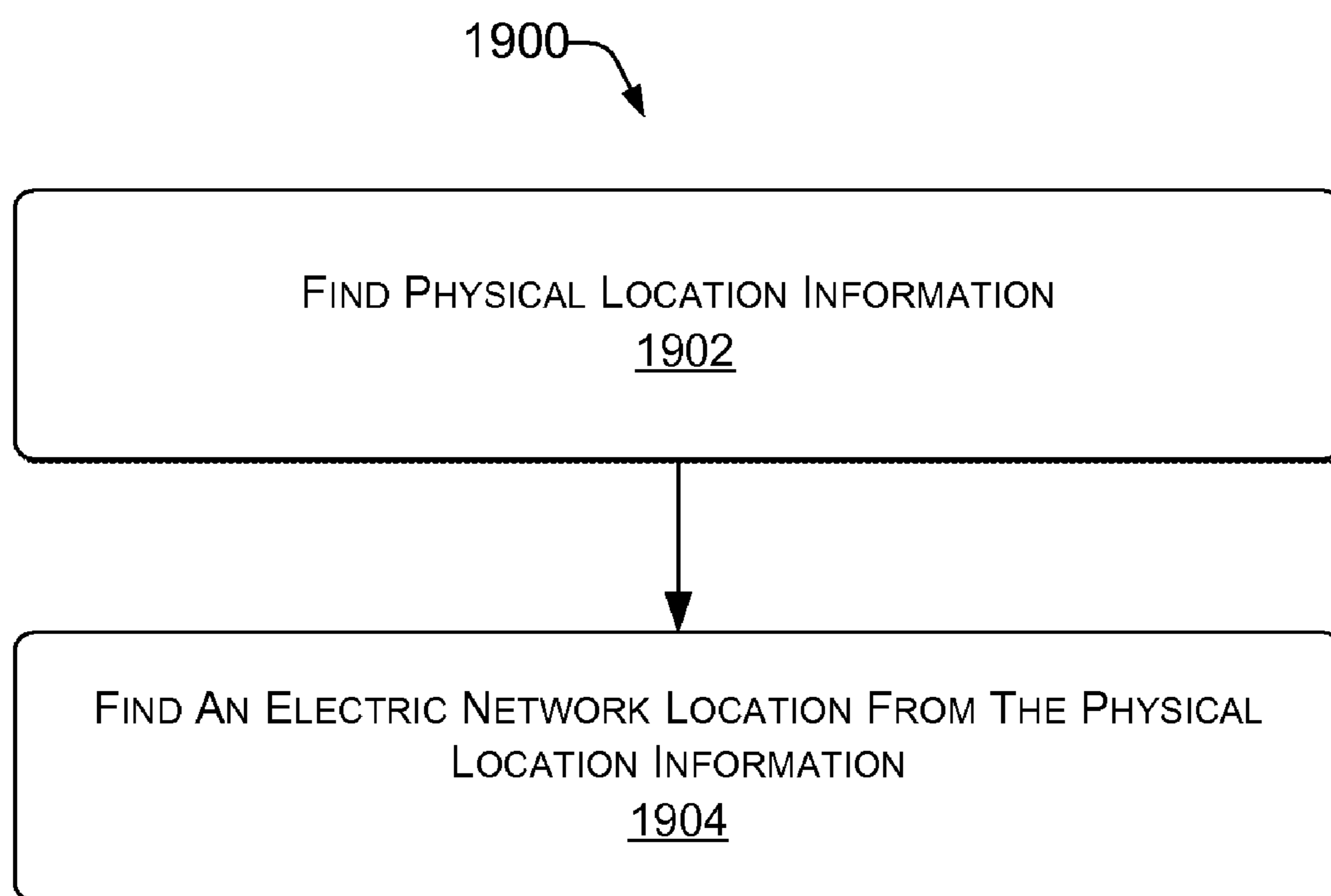

Fig. 19

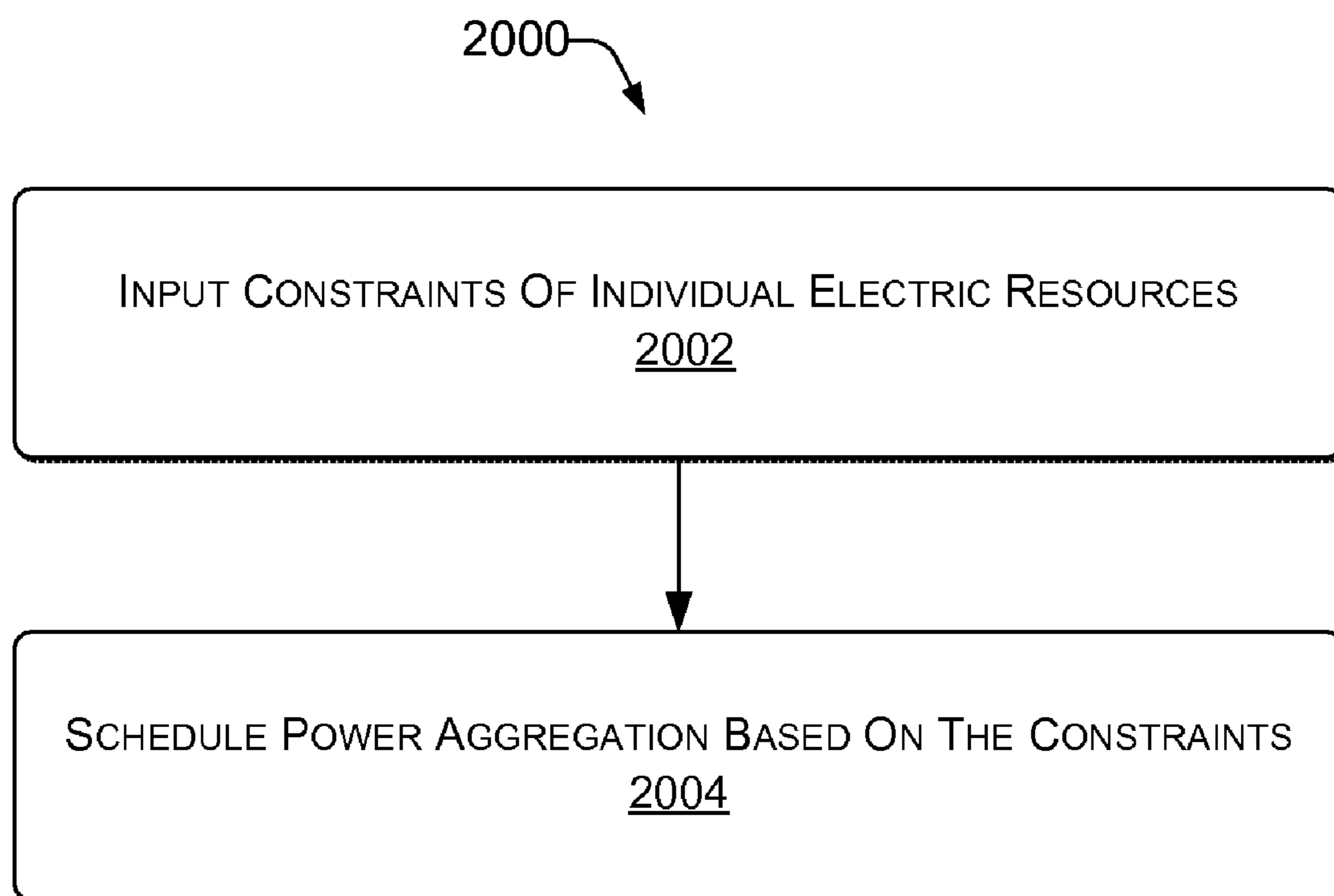

Fig. 20

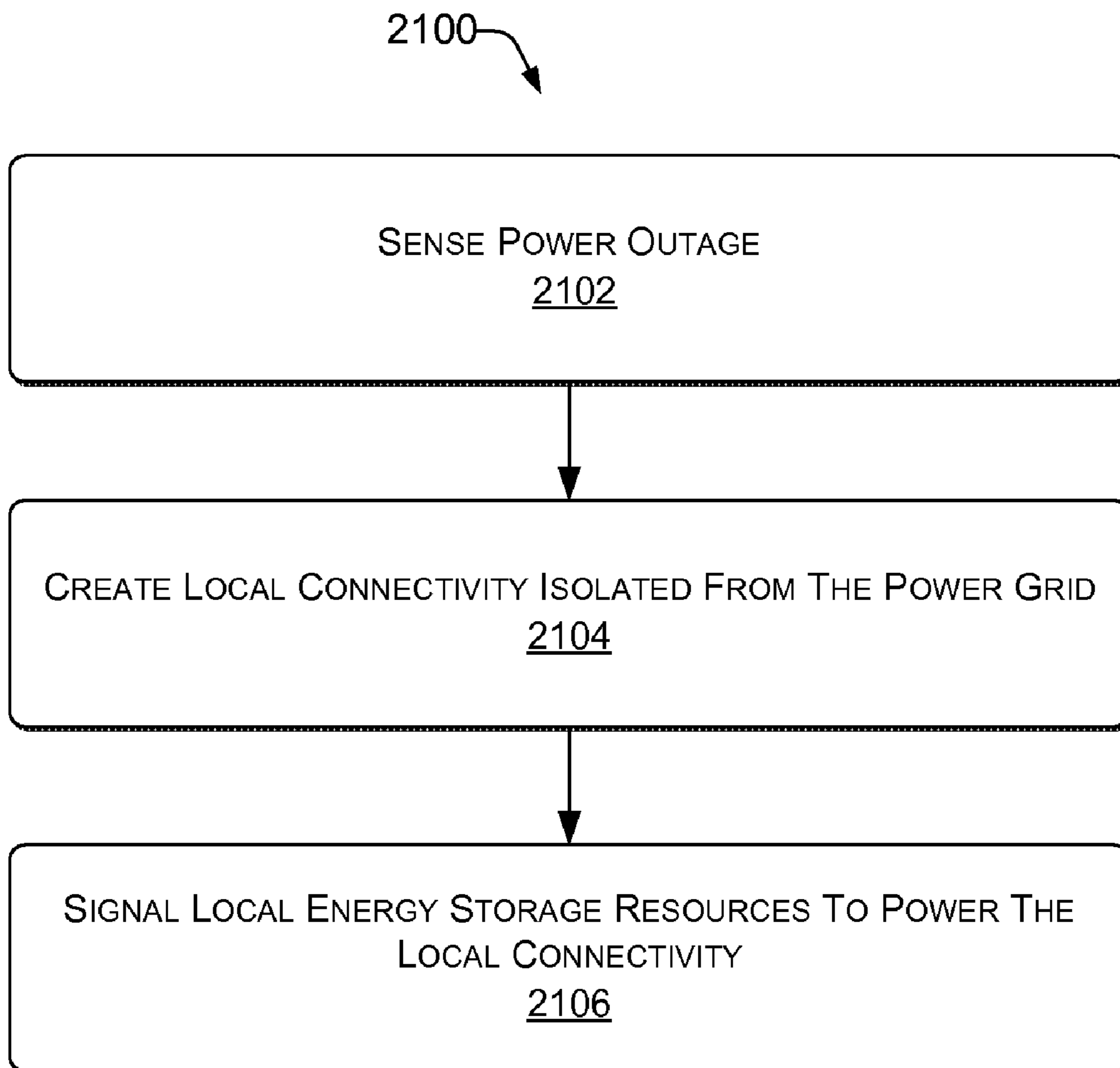

Fig. 21

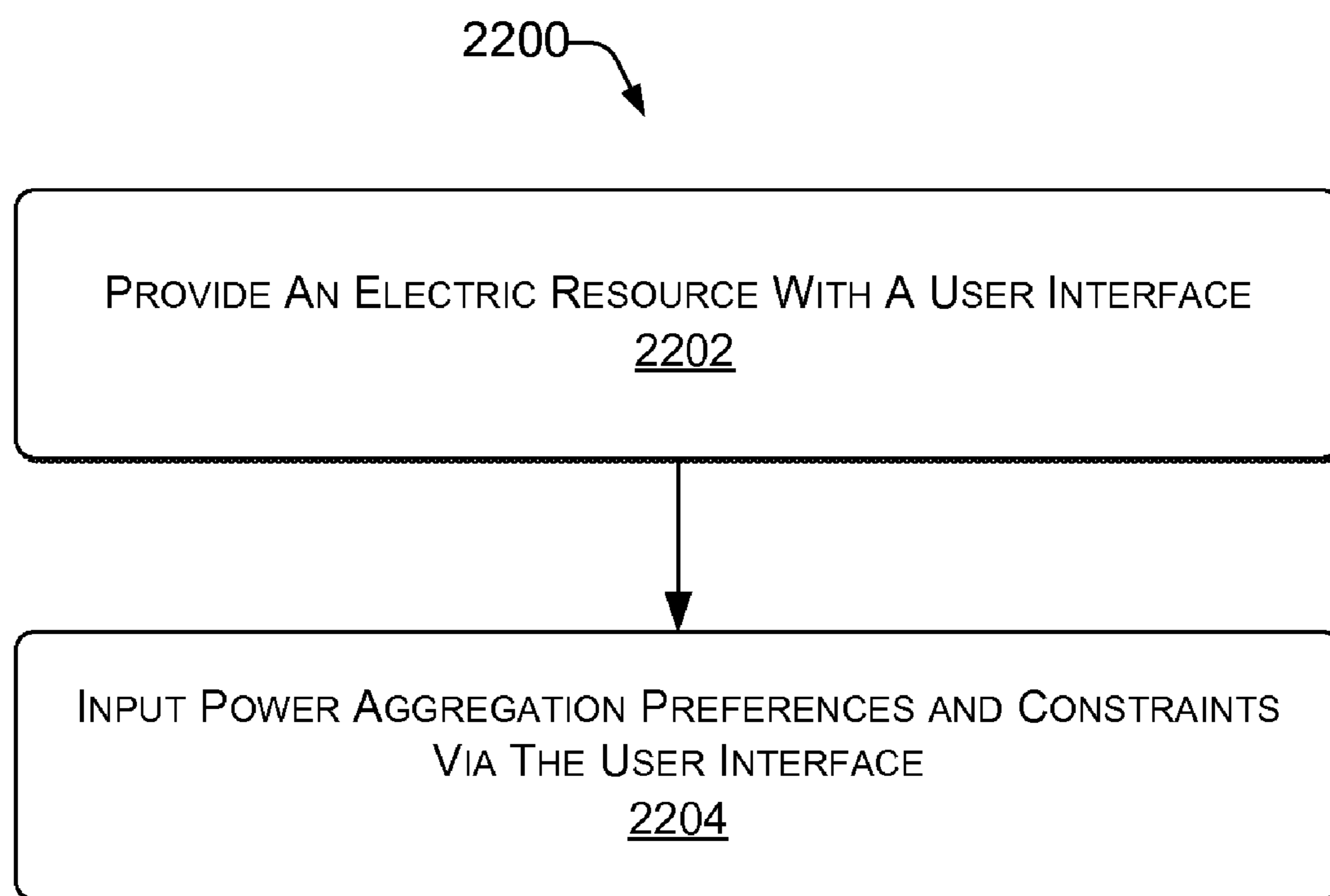

Fig. 22



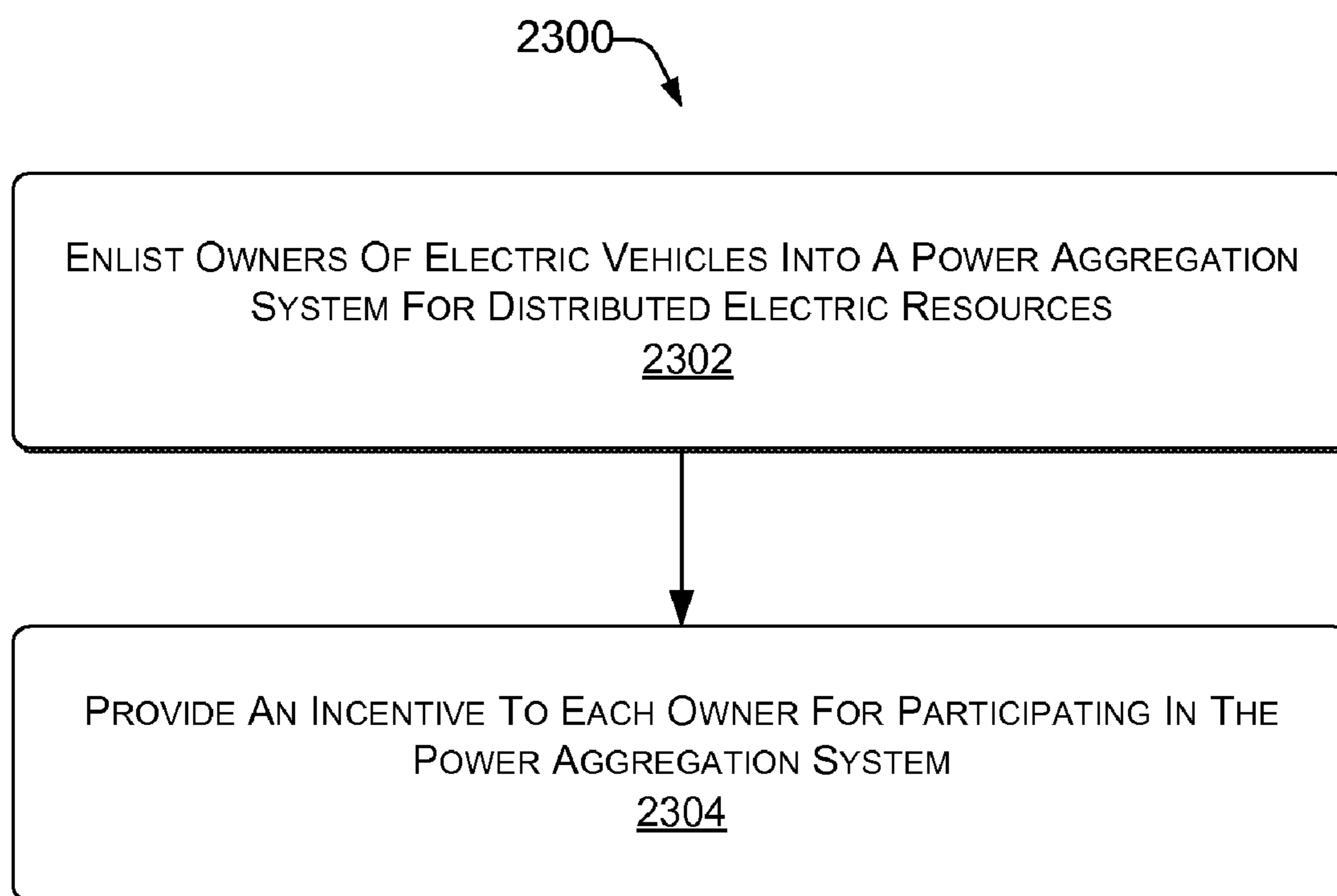

Fig. 23

**CONNECTION LOCATOR IN A POWER  
AGGREGATION SYSTEM FOR  
DISTRIBUTED ELECTRIC RESOURCES**

RELATED APPLICATIONS

**[0001]** This application is a continuation of U.S. patent application Ser. No. 11/836,747 filed Aug. 9, 2007, incorporated herein by reference, which claims priority to U.S. Provisional Patent Application No. 60/822,047 to David L. Kaplan, entitled, “Vehicle-to-Grid Power Flow Management System,” filed Aug. 10, 2006 and incorporated herein by reference; U.S. Provisional Patent Application No. 60/869,439 to Seth W. Bridges, David L. Kaplan, and Seth B. Pollack, entitled, “A Distributed Energy Storage Management System,” filed Dec. 11, 2006 and incorporated herein by reference; and U.S. Provisional Patent Application No. 60/915,347 to Seth Bridges, Seth Pollack, and David Kaplan, entitled, “Plug-In-Vehicle Management System,” filed May 1, 2007 and incorporated herein by reference.

**[0002]** This application is also related to U.S. patent application Ser. No. 11/836,741, entitled, “Power Aggregation System for Distributed Electric Resources” by Kaplan et al., filed on Aug. 9, 2007, and incorporated herein by reference; to U.S. patent application Ser. No. 11/836,743, entitled, “Electric Resource Module in a Power Aggregation System for Distributed Electric Resources” by Bridges et al., filed on Aug. 9, 2007, and incorporated herein by reference; to U.S. patent application Ser. No. 11/836,745, entitled, “Electric Resource Power Meter in a Power Aggregation System for Distributed Electric Resources” by Bridges et al., filed on Aug. 9, 2007, and incorporated herein by reference; to U.S. patent application Ser. No. 11/836,749, entitled, “Scheduling and Control in a Power Aggregation System for Distributed Electric Resources” by Pollack et al., filed on Aug. 9, 2007, and incorporated herein by reference; to U.S. patent application Ser. No. 11/836,752, entitled, “Smart Islanding and Power Backup in a Power Aggregation System for Distributed Electric Resources” by Bridges et al., filed on Aug. 9, 2007, and incorporated herein by reference; to U.S. patent application Ser. No. 11/836,756, entitled, “User Interface and User Control in a Power Aggregation System for Distributed Electric Resources” by Pollack et al., filed on Aug. 9, 2007, and incorporated herein by reference; and to U.S. patent application Ser. No. 11/836,760, entitled, “Business Methods in a Power Aggregation System for Distributed Electric Resources” by Pollack et al., filed concurrently on Aug. 9, 2007, and incorporated herein by reference.

BACKGROUND

**[0003]** Today’s electric power and transportation systems suffer from a number of drawbacks. Pollution, especially greenhouse gas emissions, is prevalent because approximately half of all electric power generated in the United States is produced by burning coal. Virtually all vehicles in the United States are powered by burning petroleum products, such as gasoline or petro-diesel. It is now widely recognized that human consumption of these fossil fuels is the major cause of elevated levels of atmospheric greenhouse gases, especially carbon dioxide (CO<sub>2</sub>), which in turn disrupts the global climate, often with destructive side effects. Besides producing greenhouse gases, burning fossil fuels also add substantial amounts of toxic pollutants to the atmosphere and environment. The transportation system, with its high

dependence on fossil fuels, is especially carbon-intensive. That is, physical units of work performed in the transportation system typically discharge a significantly larger amount of CO<sub>2</sub> into the atmosphere than the same units of work performed electrically.

**[0004]** With respect to the electric power grid, expensive peak power—electric power delivered during periods of peak demand—can cost substantially more than off-peak power. The electric power grid itself has become increasingly unreliable and antiquated, as evidenced by frequent large-scale power outages. Grid instability wastes energy, both directly and indirectly (for example, by encouraging power consumers to install inefficient forms of backup generation).

**[0005]** While clean forms of energy generation, such as wind and solar, can help to address the above problems, they suffer from intermittency. Hence, grid operators are reluctant to rely heavily on these sources, making it difficult to move away from standard, typically carbon-intensive forms of electricity.

**[0006]** The electric power grid contains limited inherent facility for storing electrical energy. Electricity must be generated constantly to meet uncertain demand, which often results in over-generation (and hence wasted energy) and sometimes results in under-generation (and hence power failures).

**[0007]** Distributed electric resources, en masse can, in principle, provide a significant resource for addressing the above problems. However, current power services infrastructure lacks provisioning and flexibility that are required for aggregating a large number of small-scale resources (e.g., electric vehicle batteries) to meet medium- and large-scale needs of power services.

**[0008]** Thus, significant opportunities for improvement exist in the electrical and transportation sectors, and in the way these sectors interact. Fuel-powered vehicles could be replaced with vehicles whose power comes entirely or substantially from electricity. Polluting forms of electric power generation could be replaced with clean ones. Real-time balancing of generation and load can be realized with reduced cost and environmental impact. More economical, reliable electrical power can be provided at times of peak demand. Power services, such as regulation and spinning reserves, can be provided to electricity markets to stabilize the grid and provide a significant economic opportunity. Technologies can be enabled to provide broader use of intermittent power sources, such as wind and solar.

**[0009]** Robust, grid-connected electrical storage could store electrical energy during periods of over-production for redelivery to the grid during periods of under-supply. Electric vehicle batteries in vast numbers could participate in this grid-connected storage. However, a single vehicle battery is insignificant when compared with the needs of the power grid. What is needed is a way to coordinate vast numbers of electric vehicle batteries, as electric vehicles become more popular and prevalent.

**[0010]** Low-level electrical and communication interfaces to enable charging and discharging of electric vehicles with respect to the grid is described in U.S. Pat. No. 5,642,270 to Green et al., entitled, “Battery powered electric vehicle and electrical supply system,” incorporated herein by reference. The Green reference describes a bi-directional charging and communication system for grid-connected electric vehicles, but does not address the information processing requirements of dealing with large, mobile populations of electric vehicles,



the complexities of billing (or compensating) vehicle owners, nor the complexities of assembling mobile pools of electric vehicles into aggregate power resources robust enough to support firm power service contracts with grid operators.

#### BRIEF DESCRIPTION OF THE DRAWINGS

[0011] FIG. 1 is a diagram of an exemplary power aggregation system.

[0012] FIG. 2 is a diagram of exemplary connections between an electric vehicle, the power grid, and the Internet.

[0013] FIG. 3 is a block diagram of exemplary connections between an electric resource and a flow control server of the power aggregation system.

[0014] FIG. 4 is a diagram of an exemplary layout of the power aggregation system.

[0015] FIG. 5 is a diagram of exemplary control areas in the power aggregation system.

[0016] FIG. 6 is a diagram of multiple flow control centers in the power aggregation system.

[0017] FIG. 7 is a block diagram of an exemplary flow control server.

[0018] FIG. 8 is block diagram of an exemplary remote intelligent power flow module.

[0019] FIG. 9 is a diagram of a first exemplary technique for locating a connection location of an electric resource on a power grid.

[0020] FIG. 10 is a diagram of a second exemplary technique for locating a connection location of an electric resource on the power grid.

[0021] FIG. 11 is a diagram of a third exemplary technique for locating a connection location of an electric resource on the power grid.

[0022] FIG. 12 is a diagram of a fourth exemplary technique for locating a connection location of an electric resource on the power grid network.

[0023] FIG. 13 is diagram of exemplary safety measures in a vehicle-to-home implementation of the power aggregation system.

[0024] FIG. 14 is a diagram of exemplary safety measures when multiple electric resources flow power to a home in the power aggregation system.

[0025] FIG. 15 is a block diagram of an exemplary smart disconnect of the power aggregation system.

[0026] FIG. 16 is a flow diagram of an exemplary method of power aggregation.

[0027] FIG. 17 is a flow diagram of an exemplary method of communicatively controlling an electric resource for power aggregation.

[0028] FIG. 18 is a flow diagram of an exemplary method of metering bidirectional power of an electric resource.

[0029] FIG. 19 is a flow diagram of an exemplary method of determining an electric network location of an electric resource.

[0030] FIG. 20 is a flow diagram of an exemplary method of scheduling power aggregation.

[0031] FIG. 21 is a flow diagram of an exemplary method of smart islanding.

[0032] FIG. 22 is a flow diagram of an exemplary method of extending a user interface for power aggregation.

[0033] FIG. 23 is a flow diagram of an exemplary method of gaining and maintaining electric vehicle owners in a power aggregation system.

#### DETAILED DESCRIPTION

##### Overview

[0034] Described herein is a power aggregation system for distributed electric resources, and associated methods. In one implementation, the exemplary system communicates over the Internet and/or some other public or private networks with numerous individual electric resources connected to a power grid (hereinafter, “grid”). By communicating, the exemplary system can dynamically aggregate these electric resources to provide power services to grid operators (e.g. utilities, Independent System Operators (ISO), etc). “Power services” as used herein, refers to energy delivery as well as other ancillary services including demand response, regulation, spinning reserves, non-spinning reserves, energy imbalance, and similar products. “Aggregation” as used herein refers to the ability to control power flows into and out of a set of spatially distributed electric resources with the purpose of providing a power service of larger magnitude. “Power grid operator” as used herein, refers to the entity that is responsible for maintaining the operation and stability of the power grid within or across an electric control area. The power grid operator may constitute some combination of manual/human action/intervention and automated processes controlling generation signals in response to system sensors. A “control area operator” is one example of a power grid operator. “Control area” as used herein, refers to a contained portion of the electrical grid with defined input and output ports. The net flow of power into this area must equal (within some error tolerance) the sum of the power consumption within the area and power outflow from the area.

[0035] “Power grid” as used herein means a power distribution system/network that connects producers of power with consumers of power. The network may include generators, transformers, interconnects, switching stations, and safety equipment as part of either/both the transmission system (i.e., bulk power) or the distribution system (i.e. retail power). The exemplary power aggregation system is vertically scalable for use with a neighborhood, a city, a sector, a control area, or (for example) one of the eight large-scale Interconnects in the North American Electric Reliability Council (NERC). Moreover, the exemplary system is horizontally scalable for use in providing power services to multiple grid areas simultaneously.

[0036] “Grid conditions” as used herein, means the need for more or less power flowing in or out of a section of the electric power grid, in a response to one of a number of conditions, for example supply changes, demand changes, contingencies and failures, ramping events, etc. These grid conditions typically manifest themselves as power quality events such as under- or over-voltage events and under- or over-frequency events.

[0037] “Power quality events” as used herein typically refers to manifestations of power grid instability including voltage deviations and frequency deviations; additionally, power quality events as used herein also includes other disturbances in the quality of the power delivered by the power grid such as sub-cycle voltage spikes and harmonics.

[0038] “Electric resource” as used herein typically refers to electrical entities that can be commanded to do some or all of these three things: take power (act as load), provide power



(act as power generation or source), and store energy. Examples may include battery/charger/inverter systems for electric or hybrid vehicles, repositories of used-but-serviceable electric vehicle batteries, fixed energy storage, fuel cell generators, emergency generators, controllable loads, etc.

[0039] “Electric vehicle” is used broadly herein to refer to pure electric and hybrid electric vehicles, such as plug-in hybrid electric vehicles (PHEVs), especially vehicles that have significant storage battery capacity and that connect to the power grid for recharging the battery. More specifically, electric vehicle means a vehicle that gets some or all of its energy for motion and other purposes from the power grid. Moreover, an electric vehicle has an energy storage system, which may consist of batteries, capacitors, etc., or some combination thereof. An electric vehicle may or may not have the capability to provide power back to the electric grid.

[0040] Electric vehicle “energy storage systems” (batteries, supercapacitors, and/or other energy storage devices) are used herein as a representative example of electric resources intermittently or permanently connected to the grid that can have dynamic input and output of power. Such batteries can function as a power source or a power load. A collection of aggregated electric vehicle batteries can become a statistically stable resource across numerous batteries, despite recognizable tidal connection trends (e.g., an increase in the total number of vehicles connected to the grid at night; a downswing in the collective number of connected batteries as the morning commute begins, etc.) Across vast numbers of electric vehicle batteries, connection trends are predictable and such batteries become a stable and reliable resource to call upon, should the grid or a part of the grid (such as a person’s home in a blackout) experience a need for increased or decreased power. Data collection and storage also enable the power aggregation system to predict connection behavior on a per-user basis.

#### Exemplary System

[0041] FIG. 1 shows an exemplary power aggregation system 100. A flow control center 102 is communicatively coupled with a network, such as a public/private mix that includes the Internet 104, and includes one or more servers 106 providing a centralized power aggregation service. “Internet” 104 will be used herein as representative of many different types of communicative networks and network mixtures. Via a network, such as the Internet 104, the flow control center 102 maintains communication 108 with operators of power grid(s), and communication 110 with remote resources, i.e., communication with peripheral electric resources 112 (“end” or “terminal” nodes/devices of a power network) that are connected to the power grid 114. In one implementation, powerline communicators (PLCs), such as those that include or consist of Ethernet-over-powerline bridges 120 are implemented at connection locations so that the “last mile” (in this case, last feet—e.g., in a residence 124) of Internet communication with remote resources is implemented over the same wire that connects each electric resource 112 to the power grid 114. Thus, each physical location of each electric resource 112 may be associated with a corresponding Ethernet-over-powerline bridge 120 (hereinafter, “bridge”) at or near the same location as the electric resource 112. Each bridge 120 is typically connected to an Internet access point of a location owner, as will be described in greater detail below. The communication medium from flow control center 102 to the connection location, such as

residence 124, can take many forms, such as cable modem, DSL, satellite, fiber, WiMax, etc. In a variation, electric resources 112 may connect with the Internet by a different medium than the same power wire that connects them to the power grid 114. For example, a given electric resource 112 may have its own wireless capability to connect directly with the Internet 104 and thereby with the flow control center 102.

[0042] Electric resources 112 of the exemplary power aggregation system 100 may include the batteries of electric vehicles connected to the power grid 114 at residences 124, parking lots 126 etc.; batteries in a repository 128, fuel cell generators, private dams, conventional power plants, and other resources that produce electricity and/or store electricity physically or electrically.

[0043] In one implementation, each participating electric resource 112 or group of local resources has a corresponding remote intelligent power flow (IPF) module 134 (hereinafter, “remote IPF module” 134). The centralized flow control center 102 administers the power aggregation system 100 by communicating with the remote IPF modules 134 distributed peripherally among the electric resources 112. The remote IPF modules 134 perform several different functions, including providing the flow control center 102 with the statuses of remote resources; controlling the amount, direction, and timing of power being transferred into or out of a remote electric resource 112; provide metering of power being transferred into or out of a remote electric resource 112; providing safety measures during power transfer and changes of conditions in the power grid 114; logging activities; and providing self-contained control of power transfer and safety measures when communication with the flow control center 102 is interrupted. The remote IPF modules 134 will be described in greater detail below.

[0044] FIG. 2 shows another view of exemplary electrical and communicative connections to an electric resource 112. In this example, an electric vehicle 200 includes a battery bank 202 and an exemplary remote IPF module 134. The electric vehicle 200 may connect to a conventional wall receptacle (wall outlet) 204 of a residence 124, the wall receptacle 204 representing the peripheral edge of the power grid 114 connected via a residential powerline 206.

[0045] In one implementation, the power cord 208 between the electric vehicle 200 and the wall outlet 204 can be composed of only conventional wire and insulation for conducting alternating current (AC) power to and from the electric vehicle 200. In FIG. 2, a location-specific connection locality module 210 performs the function of network access point—in this case, the Internet access point. A bridge 120 intervenes between the receptacle 204 and the network access point so that the power cord 208 can also carry network communications between the electric vehicle 200 and the receptacle 204. With such a bridge 120 and connection locality module 210 in place in a connection location, no other special wiring or physical medium is needed to communicate with the remote IPF module 134 of the electric vehicle 200 other than a conventional power cord 208 for providing residential line current at conventional voltage. Upstream of the connection locality module 210, power and communication with the electric vehicle 200 are resolved into the powerline 206 and an Internet cable 104.

[0046] Alternatively, the power cord 208 may include safety features not found in conventional power and extension cords. For example, an electrical plug 212 of the power cord 208 may include electrical and/or mechanical safeguard com-



ponents to prevent the remote IPF module **134** from electrifying or exposing the male conductors of the power cord **208** when the conductors are exposed to a human user.

[0047] FIG. 3 shows another implementation of the connection locality module **210** of FIG. 2, in greater detail. In FIG. 3, an electric resource **112** has an associated remote IPF module **134**, including a bridge **120**. The power cord **208** connects the electric resource **112** to the power grid **114** and also to the connection locality module **210** in order to communicate with the flow control server **106**.

[0048] The connection locality module **210** includes another instance of a bridge **120'**, connected to a network access point **302**, which may include such components as a router, switch, and/or modem, to establish a hardwired or wireless connection with, in this case, the Internet **104**. In one implementation, the power cord **208** between the two bridges **120** and **120'** is replaced by a wireless Internet link, such as a wireless transceiver in the remote IPF module **134** and a wireless router in the connection locality module **210**.

#### Exemplary System Layouts

[0049] FIG. 4 shows an exemplary layout **400** of the power aggregation system **100**. The flow control center **102** can be connected to many different entities, e.g., via the Internet **104**, for communicating and receiving information. The exemplary layout **400** includes electric resources **112**, such as plug-in electric vehicles **200**, physically connected to the grid within a single control area **402**. The electric resources **112** become an energy resource for grid operators **404** to utilize.

[0050] The exemplary layout **400** also includes end users **406** classified into electric resource owners **408** and electrical connection location owners **410**, who may or may not be one and the same. In fact, the stakeholders in an exemplary power aggregation system **100** include the system operator at the flow control center **102**, the grid operator **404**, the resource owner **408**, and the owner of the location **410** at which the electric resource **112** is connected to the power grid **114**.

[0051] Electrical connection location owners **410** can include:

[0052] Rental car lots—rental car companies often have a large portion of their fleet parked in the lot. They can purchase fleets of electric vehicles **200** and, participating in a power aggregation system **100**, generate revenue from idle fleet vehicles.

[0053] Public parking lots—parking lot owners can participate in the power aggregation system **100** to generate revenue from parked electric vehicles **200**. Vehicle owners can be offered free parking, or additional incentives, in exchange for providing power services.

[0054] Workplace parking—employers can participate in a power aggregation system **100** to generate revenue from parked employee electric vehicles **200**. Employees can be offered incentives in exchange for providing power services.

[0055] Residences—a home garage can merely be equipped with a connection locality module **210** to enable the homeowner to participate in the power aggregation system **100** and generate revenue from a parked car. Also, the vehicle battery **202** and associated power electronics within the vehicle can provide local power backup power during times of peak load or power outages.

[0056] Residential neighborhoods—neighborhoods can participate in a power aggregation system **100** and be equipped with power-delivery devices (deployed, for

example, by homeowner cooperative groups) that generate revenue from parked electric vehicles **200**.

[0057] The grid operations **116** of FIG. 4 collectively include interactions with energy markets **412**, the interactions of grid operators **404**, and the interactions of automated grid controllers **118** that perform automatic physical control of the power grid **114**.

[0058] The flow control center **102** may also be coupled with information sources **414** for input of weather reports, events, price feeds, etc. Other data sources **414** include the system stakeholders, public databases, and historical system data, which may be used to optimize system performance and to satisfy constraints on the exemplary power aggregation system **100**.

[0059] Thus, an exemplary power aggregation system **100** may consist of components that:

[0060] communicate with the electric resources **112** to gather data and actuate charging/discharging of the electric resources **112**;

[0061] gather real-time energy prices;

[0062] gather real-time resource statistics;

[0063] predict behavior of electric resources **112** (connect- edness, location, state (such as battery State-Of-Charge) at time of connect/disconnect);

[0064] predict behavior of the power grid **114**/load;

[0065] encrypt communications for privacy and data secu- rity;

[0066] actuate charging of electric vehicles **200** to optimize some figure(s) of merit;

[0067] offer guidelines or guarantees about load availabil- ity for various points in the future, etc.

[0068] These components can be running on a single com- puting resource (computer, etc.), or on a distributed set of resources (either physically co-located or not).

[0069] Exemplary IPF systems **100** in such a layout **400** can provide many benefits: for example, lower-cost ancillary ser- vices (i.e., power services), fine-grained (both temporally and spatially) control over resource scheduling, guaranteed reli- ability and service levels, increased service levels via intelli- gent resource scheduling, firming of intermittent generation sources such as wind and solar power generation.

[0070] The exemplary power aggregation system **100** enables a grid operator **404** to control the aggregated electric resources **112** connected to the power grid **114**. An electric resource **112** can act as a power source, load, or storage, and the resource **112** may exhibit combinations of these proper- ties. Control of an electric resource **112** is the ability to actuate power consumption, generation, or energy storage from an aggregate of these electric resources **112**.

[0071] FIG. 5 shows the role of multiple control areas **402** in the exemplary power aggregation system **100**. Each elec- tric resource **112** can be connected to the power aggregation system **100** within a specific electrical control area. A single instance of the flow control center **102** can administer electric resources **112** from multiple distinct control areas **501** (e.g., control areas **502**, **504**, and **506**). In one implementation, this functionality is achieved by logically partitioning resources within the power aggregation system **100**. For example, when the control areas **402** include an arbitrary number of control areas, control area “A” **502**, control area “B” **504**, . . . , control area “n” **506**, then grid operations **116** can include corre- sponding control area operators **508**, **510**, . . . , and **512**. Further division into a control hierarchy that includes control division groupings above and below the illustrated control



areas **402** allows the power aggregation system **100** to scale to power grids **114** of different magnitudes and/or to varying numbers of electric resources **112** connected with a power grid **114**.

[0072] FIG. 6 shows an exemplary layout **600** of an exemplary power aggregation system **100** that uses multiple centralized flow control centers **102** and **102'**. Each flow control center **102** and **102'** has its own respective end users **406** and **406'**. Control areas **402** to be administered by each specific instance of a flow control center **102** can be assigned dynamically. For example, a first flow control center **102** may administer control area A **502** and control area B **504**, while a second flow control center **102'** administers control area n **506**. Likewise, corresponding control area operators (**508**, **510**, and **512**) are served by the same flow control center **102** that serves their respective different control areas.

#### Exemplary Flow Control Server

[0073] FIG. 7 shows an exemplary server **106** of the flow control center **102**. The illustrated implementation in FIG. 7 is only one example configuration, for descriptive purposes. Many other arrangements of the illustrated components or even different components constituting an exemplary server **106** of the flow control center **102** are possible within the scope of the subject matter. Such an exemplary server **106** and flow control center **102** can be executed in hardware, software, or combinations of hardware, software, firmware, etc.

[0074] The exemplary flow control server **106** includes a connection manager **702** to communicate with electric resources **112**, a prediction engine **704** that may include a learning engine **706** and a statistics engine **708**, a constraint optimizer **710**, and a grid interaction manager **712** to receive grid control signals **714**. Grid control signals **714** are sometimes referred to as generation control signals, such as automated generation control (AGC) signals. The flow control server **106** may further include a database/information warehouse **716**, a web server **718** to present a user interface to electric resource owners **408**, grid operators **404**, and electrical connection location owners **410**; a contract manager **720** to negotiate contract terms with energy markets **412**, and an information acquisition engine **414** to track weather, relevant news events, etc., and download information from public and private databases **722** for predicting behavior of large groups of the electric resources **112**, monitoring energy prices, negotiating contracts, etc.

#### Operation of an Exemplary Flow Control Server

[0075] The connection manager **702** maintains a communications channel with each electric resource **112** that is connected to the power aggregation system **100**. That is, the connection manager **702** allows each electric resource **112** to log on and communicate, e.g., using Internet Protocol (IP) if the network is the Internet **104**. In other words, the electric resources **112** call home. That is, in one implementation they always initiate the connection with the server **106**. This facet enables the exemplary IPF modules **134** to work around problems with firewalls, IP addressing, reliability, etc.

[0076] For example, when an electric resource **112**, such as an electric vehicle **200** plugs in at home **124**, the IPF module **134** can connect to the home's router via the powerline connection. The router will assign the vehicle **200** an address (DHCP), and the vehicle **200** can connect to the server **106** (no holes in the firewall needed from this direction).

[0077] If the connection is terminated for any reason (including the server instance dies), then the IPF module **134** knows to call home again and connect to the next available server resource.

[0078] The grid interaction manager **712** receives and interprets signals from the interface of the automated grid controller **118** of a grid operator **404**. In one implementation, the grid interaction manager **712** also generates signals to send to automated grid controllers **118**. The scope of the signals to be sent depends on agreements or contracts between grid operators **404** and the exemplary power aggregation system **100**. In one scenario the grid interaction manager **712** sends information about the availability of aggregate electric resources **112** to receive power from the grid **114** or supply power to the grid **114**. In another variation, a contract may allow the grid interaction manager **712** to send control signals to the automated grid controller **118**—to control the grid **114**, subject to the built-in constraints of the automated grid controller **118** and subject to the scope of control allowed by the contract.

[0079] The database **716** can store all of the data relevant to the power aggregation system **100** including electric resource logs, e.g., for electric vehicles **200**, electrical connection information, per-vehicle energy metering data, resource owner preferences, account information, etc.

[0080] The web server **718** provides a user interface to the system stakeholders, as described above. Such a user interface serves primarily as a mechanism for conveying information to the users, but in some cases, the user interface serves to acquire data, such as preferences, from the users. In one implementation, the web server **718** can also initiate contact with participating electric resource owners **408** to advertise offers for exchanging electrical power.

[0081] The bidding/contract manager **720** interacts with the grid operators **404** and their associated energy markets **412** to determine system availability, pricing, service levels, etc.

[0082] The information acquisition engine **414** communicates with public and private databases **722**, as mentioned above, to gather data that is relevant to the operation of the power aggregation system **100**.

[0083] The prediction engine **704** may use data from the data warehouse **716** to make predictions about electric resource behavior, such as when electric resources **112** will connect and disconnect, global electric resource availability, electrical system load, real-time energy prices, etc. The predictions enable the power aggregation system **100** to utilize more fully the electric resources **112** connected to the power grid **114**. The learning engine **706** may track, record, and process actual electric resource behavior, e.g., by learning behavior of a sample or cross-section of a large population of electric resources **112**. The statistics engine **708** may apply various probabilistic techniques to the resource behavior to note trends and make predictions.

[0084] In one implementation, the prediction engine **704** performs predictions via collaborative filtering. The prediction engine **704** can also perform per-user predictions of one or more parameters, including, for example, connect-time, connect duration, state-of-charge at connect time, and connection location. In order to perform per-user prediction, the prediction engine **704** may draw upon information, such as historical data, connect time (day of week, week of month, month of year, holidays, etc.), state-of-charge at connect, connection location, etc. In one implementation, a time series



prediction can be computed via a recurrent neural network, a dynamic Bayesian network, or other directed graphical model.

[0085] In one scenario, for one user disconnected from the grid **114**, the prediction engine **704** can predict the time of the next connection, the state-of-charge at connection time, the location of the connection (and may assign it a probability/likelihood). Once the resource **112** has connected, the time-of-connection, state-of-charge at-connection, and connection location become further inputs to refinements of the predictions of the connection duration. These predictions help to guide predictions of total system availability as well as to determine a more accurate cost function for resource allocation.

[0086] Building a parameterized prediction model for each unique user is not always scalable in time or space. Therefore, in one implementation, rather than use one model for each user in the system **100**, the prediction engine **704** builds a reduced set of models where each model in the reduced set is used to predict the behavior of many users. To decide how to group similar users for model creation and assignment, the system **100** can identify features of each user, such as number of unique connections/disconnections per day, typical connection time(s), average connection duration, average state-of-charge at connection time, etc., and can create clusters of users in either a full feature space or in some reduced feature space that is computed via a dimensionality reduction algorithm such as Principal Components Analysis, Random Projection, etc. Once the prediction engine **704** has assigned users to a cluster, the collective data from all of the users in that cluster is used to create a predictive model that will be used for the predictions of each user in the cluster. In one implementation, the cluster assignment procedure is varied to optimize the system **100** for speed (less clusters), for accuracy (more clusters), or some combination of the two.

[0087] This exemplary clustering technique has multiple benefits. First, it enables a reduced set of models, and therefore reduced model parameters, which reduces the computation time for making predictions. It also reduces the storage space of the model parameters. Second, by identifying traits (or features) of new users to the system **100**, these new users can be assigned to an existing cluster of users with similar traits, and the cluster model, built from the extensive data of the existing users, can make more accurate predictions about the new user more quickly because it is leveraging the historical performance of similar users. Of course, over time, individual users may change their behaviors and may be reassigned to new clusters that fit their behavior better.

[0088] The constraint optimizer **710** combines information from the prediction engine **704**, the data warehouse **716**, and the contract manager **720** to generate resource control signals that will satisfy the system constraints. For example, the constraint optimizer **710** can signal an electric vehicle **200** to charge its battery bank **202** at a certain charging rate and later to discharge the battery bank **202** for uploading power to the power grid **114** at a certain upload rate: the power transfer rates and the timing schedules of the power transfers optimized to fit the tracked individual connect and disconnect behavior of the particular electric vehicle **200** and also optimized to fit a daily power supply and demand “breathing cycle” of the power grid **114**.

[0089] In one implementation, the constraint optimizer **710** plays a key role in converting generation control signals **714** into vehicle control signals, mediated by the connection man-

ager **702**. Mapping generation control signals **714** from a grid operator **404** into control signals that are sent to each unique electrical resource **112** in the system **100** is an example of a specific constraint optimization problem.

[0090] Each resource **112** has associated constraints, either hard or soft. Examples of resource constraints may include: price sensitivity of the owner, vehicle state-of-charge (e.g., if the vehicle **200** is fully charged, it cannot participate in loading the grid **114**), predicted amount of time until the resource **112** disconnects from the system **100**, owner sensitivity to revenue versus state-of-charge, electrical limits of the resource **114**, manual charging overrides by resource owners **408**, etc. The constraints on a particular resource **112** can be used to assign a cost for activating each of the resource’s particular actions. For example, a resource whose storage system **202** has little energy stored in it will have a low cost associated with the charging operation, but a very high cost for the generation operation. A fully charged resource **112** that is predicted to be available for ten hours will have a lower cost generation operation than a fully charged resource **112** that is predicted to be disconnected within the next 15 minutes, representing the negative consequence of delivering a less-than-full resource to its owner.

[0091] The following is one example scenario of converting one generating signal **714** that comprises a system operating level (e.g.  $-10$  megawatts to  $+10$  megawatts, where  $+$  represents load,  $-$  represents generation) to a vehicle control signal. It is worth noting that because the system **100** can meter the actual power flows in each resource **112**, the actual system operating level is known at all times.

[0092] In this example, assume the initial system operating level is  $0$  megawatts, no resources are active (taking or delivering power from the grid), and the negotiated aggregation service contract level for the next hour is  $+/-5$  megawatts.

[0093] In this implementation, the exemplary power aggregation system **100** maintains three lists of available resources **112**. The first list contains resources **112** that can be activated for charging (load) in priority order. There is a second list of the resources **112** ordered by priority for discharging (generation). Each of the resources **112** in these lists (e.g., all resources **112** can have a position in both lists) have an associated cost. The priority order of the lists is directly related to the cost (i.e., the lists are sorted from lowest cost to highest cost). Assigning cost values to each resource **112** is important because it enables the comparison of two operations that achieve similar results with respect to system operation. For example, adding one unit of charging (load, taking power from the grid) to the system is equivalent to removing one unit of generation. To perform any operation that increases or decreases the system output, there may be multiple action choices and in one implementation the system **100** selects the lowest cost operation. The third list of resources **112** contains resources with hard constraints. For example, resources whose owner’s **408** have overridden the system **100** to force charging will be placed on the third list of static resources.

[0094] At time “1,” the grid-operator-requested operating level changes to  $+2$  megawatts. The system activates charging the first ‘n’ resources from the list, where ‘n’ is the number of resources whose additive load is predicted to equal  $2$  megawatts. After the resources are activated, the result of the activations are monitored to determine the actual result of the action. If more than  $2$  megawatts of load is active, the system



will disable charging in reverse priority order to maintain system operation within the error tolerance specified by the contract.

**[0095]** From time “1” until time “2,” the requested operating level remains constant at 2 megawatts. However, the behavior of some of the electrical resources may not be static. For example, some vehicles **200** that are part of the 2 megawatts system operation may become full (state-of-charge=100%) or may disconnect from the system **100**. Other vehicles **200** may connect to the system **100** and demand immediate charging. All of these actions will cause a change in the operating level of the power aggregation system **100**. Therefore, the system **100** continuously monitors the system operating level and activates or deactivates resources **112** to maintain the operating level within the error tolerance specified by the contract.

**[0096]** At time “2,” the grid-operator-requested operating level decreases to –1 megawatts. The system consults the lists of available resources and chooses the lowest cost set of resources to achieve a system operating level of –1 megawatts. Specifically, the system moves sequentially through the priority lists, comparing the cost of enabling generation versus disabling charging, and activating the lowest cost resource at each time step. Once the operating level reaches –1 megawatts, the system **100** continues to monitor the actual operating level, looking for deviations that would require the activation of an additional resource **112** to maintain the operating level within the error tolerance specified by the contract.

**[0097]** In one implementation, an exemplary costing mechanism is fed information on the real-time grid generation mix to determine the marginal consequences of charging or generation (vehicle **200** to grid **114**) on a “carbon footprint,” the impact on fossil fuel resources and the environment in general. The exemplary system **100** also enables optimizing for any cost metric, or a weighted combination of several. The system **100** can optimize figures of merit that may include, for example, a combination of maximizing economic value and minimizing environmental impact, etc.

**[0098]** In one implementation, the system **100** also uses cost as a temporal variable. For example, if the system **100** schedules a discharged pack to charge during an upcoming time window, the system **100** can predict its look-ahead cost profile as it charges, allowing the system **100** to further optimize, adaptively. That is, in some circumstances the system **100** knows that it will have a high-capacity generation resource by a certain future time.

**[0099]** Multiple components of the flow control server **106** constitute a scheduling system that has multiple functions and components:

**[0100]** data collection (gathers real-time data and stores historical data);

**[0101]** projections via the prediction engine **704**, which inputs real-time data, historical data, etc.; and outputs resource availability forecasts;

**[0102]** optimizations built on resource availability forecasts, constraints, such as command signals from grid operators **404**, user preferences, weather conditions, etc. The optimizations can take the form of resource control plans that optimize a desired metric.

**[0103]** The scheduling function can enable a number of useful energy services, including:

**[0104]** ancillary services, such as rapid response services and fast regulation;

**[0105]** energy to compensate for sudden, foreseeable, or unexpected grid imbalances;

**[0106]** response to routine and unstable demands;

**[0107]** firming of renewable energy sources (e.g. complementing wind-generated power).

**[0108]** An exemplary power aggregation system **100** aggregates and controls the load presented by many charging/uploading electric vehicles **200** to provide power services (ancillary energy services) such as regulation and spinning reserves. Thus, it is possible to meet call time requirements of grid operators **404** by summing multiple electric resources **112**. For example, twelve operating loads of 5 kW each can be disabled to provide 60 kW of spinning reserves for one hour. However, if each load can be disabled for at most 30 minutes and the minimum call time is two hours, the loads can be disabled in series (three at a time) to provide 15 kW of reserves for two hours. Of course, more complex interleavings of individual electric resources by the power aggregation system **100** are possible.

**[0109]** For a utility (or electrical power distribution entity) to maximize distribution efficiency, the utility needs to minimize reactive power flows. Typically, there are a number of methods used to minimize reactive power flows including switching inductor or capacitor banks into the distribution system to modify the power factor in different parts of the system. To manage and control this dynamic Volt-Amperes Reactive (VAR) support effectively, it must be done in a location-aware manner. In one implementation, the power aggregation system **100** includes power-factor correction circuitry placed in electric vehicles **200** with the exemplary remote IPF module **134**, thus enabling such a service. Specifically, the electric vehicles **200** can have capacitors (or inductors) that can be dynamically connected to the grid, independent of whether the electric vehicle **200** is charging, delivering power, or doing nothing. This service can then be sold to utilities for distribution level dynamic VAR support. The power aggregation system **100** can both sense the need for VAR support in a distributed manner and use the distributed remote IPF modules **134** to take actions that provide VAR support without grid operator **404** intervention.

#### Exemplary Remote IPF Module

**[0110]** FIG. 8 shows the remote IPF module **134** of FIGS. 1 and 2 in greater detail. The illustrated remote IPF module **134** is only one example configuration, for descriptive purposes. Many other arrangements of the illustrated components or even different components constituting an exemplary remote IPF module **134** are possible within the scope of the subject matter. Such an exemplary remote IPF module **134** has some hardware components and some components that can be executed in hardware, software, or combinations of hardware, software, firmware, etc.

**[0111]** The illustrated example of a remote IPF module **134** is represented by an implementation suited for an electric vehicle **200**. Thus, some vehicle systems **800** are included as part of the exemplary remote IPF module **134** for the sake of description. However, in other implementations, the remote IPF module **134** may exclude some or all of the vehicle systems **800** from being counted as components of the remote IPF module **134**.

**[0112]** The depicted vehicle systems **800** include a vehicle computer and data interface **802**, an energy storage system, such as a battery bank **202**, and an inverter/charger **804**. Besides vehicle systems **800**, the remote IPF module **134** also



includes a communicative power flow controller **806**. The communicative power flow controller **806** in turn includes some components that interface with AC power from the grid **114**, such as a powerline communicator, for example an Ethernet-over-powerline bridge **120**, and a current or current/voltage (power) sensor **808**, such as a current sensing transformer.

[0113] The communicative power flow controller **806** also includes Ethernet and information processing components, such as a processor **810** or microcontroller and an associated Ethernet media access control (MAC) address **812**; volatile random access memory **814**, nonvolatile memory **816** or data storage, an interface such as an RS-232 interface **818** or a CANbus interface **820**; an Ethernet physical layer interface **822**, which enables wiring and signaling according to Ethernet standards for the physical layer through means of network access at the MAC/Data Link Layer and a common addressing format. The Ethernet physical layer interface **822** provides electrical, mechanical, and procedural interface to the transmission medium—i.e., in one implementation, using the Ethernet-over-powerline bridge **120**. In a variation, wireless or other communication channels with the Internet **104** are used in place of the Ethernet-over-powerline bridge **120**.

[0114] The communicative power flow controller **806** also includes a bidirectional power flow meter **824** that tracks power transfer to and from each electric resource **112**, in this case the battery bank **202** of an electric vehicle **200**.

[0115] The communicative power flow controller **806** operates either within, or connected to an electric vehicle **200** or other electric resource **112** to enable the aggregation of electric resources **112** introduced above (e.g., via a wired or wireless communication interface). These above-listed components may vary among different implementations of the communicative power flow controller **806**, but implementations typically include:

[0116] an intra-vehicle communications mechanism that enables communication with other vehicle components;

[0117] a mechanism to communicate with the flow control center **102**;

[0118] a processing element;

[0119] a data storage element;

[0120] a power meter; and

[0121] optionally, a user interface.

[0122] Implementations of the communicative power flow controller **806** can enable functionality including:

[0123] executing pre-programmed or learned behaviors when the electric resource **112** is offline (not connected to Internet **104**, or service is unavailable);

[0124] storing locally-cached behavior profiles for “roaming” connectivity (what to do when charging on a foreign system or in disconnected operation, i.e., when there is no network connectivity);

[0125] allowing the user to override current system behavior; and

[0126] metering power-flow information and caching meter data during offline operation for later transaction.

[0127] Thus, the communicative power flow controller **806** includes a central processor **810**, interfaces **818** and **820** for communication within the electric vehicle **200**, a powerline communicator, such as an Ethernet-over-powerline bridge **120** for communication external to the electric vehicle **200**,

and a power flow meter **824** for measuring energy flow to and from the electric vehicle **200** via a connected AC powerline **208**.

#### Operation of the Exemplary Remote IPF Module

[0128] Continuing with electric vehicles **200** as representative of electric resources **112**, during periods when such an electric vehicle **200** is parked and connected to the grid **114**, the remote IPF module **134** initiates a connection to the flow control server **106**, registers itself, and waits for signals from the flow control server **106** that direct the remote IPF module **134** to adjust the flow of power into or out of the electric vehicle **200**. These signals are communicated to the vehicle computer **802** via the data interface, which may be any suitable interface including the RS-232 interface **818** or the CANbus interface **820**. The vehicle computer **802**, following the signals received from the flow control server **106**, controls the inverter/charger **804** to charge the vehicle’s battery bank **202** or to discharge the battery bank **202** in upload to the grid **114**.

[0129] Periodically, the remote IPF module **134** transmits information regarding energy flows to the flow control server **106**. If, when the electric vehicle **200** is connected to the grid **114**, there is no communications path to the flow control server **106** (i.e., the location is not equipped properly, or there is a network failure), the electric vehicle **200** can follow a preprogrammed or learned behavior of off-line operation, e.g., stored as a set of instructions in the nonvolatile memory **816**. In such a case, energy transactions can also be cached in nonvolatile memory **816** for later transmission to the flow control server **106**.

[0130] During periods when the electric vehicle **200** is in operation as transportation, the remote IPF module **134** listens passively, logging select vehicle operation data for later analysis and consumption. The remote IPF module **134** can transmit this data to the flow control server **106** when a communications channel becomes available.

#### Exemplary Power Flow Meter

[0131] Power is the rate of energy consumption per interval of time. Power indicates the quantity of energy transferred during a certain period of time, thus the units of power are quantities of energy per unit of time. The exemplary power flow meter **824** measures power for a given electric resource **112** across a bidirectional flow—e.g., power from grid **114** to electric vehicle **200** or from electric vehicle **200** to the grid **114**. In one implementation, the remote IPF module **134** can locally cache readings from the power flow meter **824** to ensure accurate transactions with the central flow control server **106**, even if the connection to the server is down temporarily, or if the server itself is unavailable.

[0132] The exemplary power flow meter **824**, in conjunction with the other components of the remote IPF module **134** enables system-wide features in the exemplary power aggregation system **100** that include:

[0133] tracking energy usage on an electric resource-specific basis;

[0134] power-quality monitoring (checking if voltage, frequency, etc. deviate from their nominal operating points, and if so, notifying grid operators, and potentially modifying resource power flows to help correct the problem);

[0135] vehicle-specific billing and transactions for energy usage;



[0136] mobile billing (support for accurate billing when the electric resource owner **408** is not the electrical connection location owner **410** (i.e., not the meter account owner). Data from the power flow meter **824** can be captured at the electric vehicle **200** for billing;

[0137] integration with a smart meter at the charging location (bidirectional information exchange); and

[0138] tamper resistance (e.g., when the power flow meter **824** is protected within an electric resource **112** such as an electric vehicle **200**).

#### Mobile Resource Locator

[0139] The exemplary power aggregation system **100** also includes various techniques for determining the electrical network location of a mobile electric resource **112**, such as a plug-in electric vehicle **200**. Electric vehicles **200** can connect to the grid **114** in numerous locations and accurate control and transaction of energy exchange can be enabled by specific knowledge of the charging location.

[0140] Some of the exemplary techniques for determining electric vehicle charging locations include:

[0141] querying a unique identifier for the location (via wired, wireless, etc.), which can be:

[0142] the unique ID of the network hardware at the charging site;

[0143] the unique ID of the locally installed smart meter, by communicating with the meter;

[0144] a unique ID installed specifically for this purpose at a site; and

[0145] using GPS or other signal sources (cell, WiMAX, etc.) to establish a “soft” (estimated geographic) location, which is then refined based on user preferences and historical data (e.g., vehicles tend to be plugged-in at the owner’s residence **124**, not a neighbor’s residence).

[0146] FIG. 9 shows an exemplary technique for resolving the physical location on the grid **114** of an electric resource **112** that is connected to the exemplary power aggregation system **100**. In one implementation, the remote IPF module **134** obtains the Media Access Control (MAC) address **902** of the locally installed network modem or router (Internet access point) **302**. The remote IPF module **134** then transmits this unique MAC identifier to the flow control server **106**, which uses the identifier to resolve the location of the electric vehicle **200**.

[0147] To discern its physical location, the remote IPF module **134** can also sometimes use the MAC addresses or other unique identifiers of other physically installed nearby equipment that can communicate with the remote IPF module **134**, including a “smart” utility meter **904**, a cable TV box **906**, an RFID-based unit **908**, or an exemplary ID unit **910** that is able to communicate with the remote IPF module **134**. The ID unit **910** is described in more detail in FIG. 10. MAC addresses **902** do not always give information about the physical location of the associated piece of hardware, but in one implementation the flow control server **106** includes a tracking database **912** that relates MAC addresses or other identifiers with an associated physical location of the hardware. In this manner, a remote IPF module **134** and the flow control server **106** can find a mobile electric resource **112** wherever it connects to the power grid **114**.

[0148] FIG. 10 shows another exemplary technique for determining a physical location of a mobile electric resource **112** on the power grid **114**. An exemplary ID unit **910** can be plugged into the grid **114** at or near a charging location. The

operation of the ID unit **910** is as follows. A newly-connected electric resource **112** searches for locally connected resources by broadcasting a ping or message in the wireless reception area. In one implementation, the ID unit **910** responds **1002** to the ping and conveys a unique identifier **1004** of the ID unit **910** back to the electric resource **112**. The remote IPF module **134** of the electric resource **112** then transmits the unique identifier **1004** to the flow control server **106**, which determines the location of the ID unit **910** and by proxy, the exact or the approximate network location of the electric resource **112**, depending on the size of the catchment area of the ID unit **910**.

[0149] In another implementation, the newly-connected electric resource **112** searches for locally connected resources by broadcasting a ping or message that includes the unique identifier **1006** of the electric resource **112**. In this implementation, the ID unit **910** does not need to trust or reuse the wireless connection, and does not respond back to the remote IPF module **134** of the mobile electric resource **112**, but responds **1008** directly to the flow control server **106** with a message that contains its own unique identifier **1004** and the unique identifier **1006** of the electric resource **112** that was received in the ping message. The central flow control server **106** then associates the unique identifier **1006** of the mobile electric resource **112** with a “connected” status and uses the other unique identifier **1004** of the ID unit **910** to determine or approximate the physical location of the electric resource **112**. The physical location does not have to be approximate, if a particular ID unit **910** is associated with only one exact network location. The remote IPF module **134** learns that the ping is successful when it hears back from the flow control center **106** with confirmation.

[0150] Such an exemplary ID unit **910** is particularly useful in situations in which the communications path between the electric resource **112** and the flow control server **106** is via a wireless connection that does not itself enable exact determination of network location.

[0151] FIG. 11 shows another exemplary method **1100** and system **1102** for determining the location of a mobile electric resource **112** on the power grid **114**. In a scenario in which the electric resource **112** and the flow control server **106** conduct communications via a wireless signaling scheme, it is still desirable to determine the physical connection location during periods of connectedness with the grid **114**.

[0152] Wireless networks (e.g., GSM, 802.11, WiMax) comprise many cells or towers that each transmit unique identifiers. Additionally, the strength of the connection between a tower and mobile clients connecting to the tower is a function of the client’s proximity to the tower. When an electric vehicle **200** is connected to the grid **114**, the remote IPF module **134** can acquire the unique identifiers of the available towers and relate these to the signal strength of each connection, as shown in database **1104**. The remote IPF module **134** of the electric resource **112** transmits this information to the flow control server **106**, where the information is combined with survey data, such as database **1106** so that a position inference engine **1108** can triangulate or otherwise infer the physical location of the connected electric vehicle **200**. In another enablement, the IPF module **134** can use the signal strength readings to resolve the resource location directly, in which case the IPF module **134** transmits the location information instead of the signal strength information.

[0153] Thus, the exemplary method **1100** includes acquiring (**1110**) the signal strength information; communicating



(1112) the acquired signal strength information to the flow control server 106; and inferring (1114) the physical location using stored tower location information and the acquired signals from the electric resource 112.

[0154] FIG. 12 shows a method 1200 and system 1202 for using signals from a global positioning satellite (GPS) system to determine a physical location of a mobile electric resource 112 on the power grid 114. Using GPS enables a remote IPF module 134 to resolve its physical location on the power network in a non-exact manner. This noisy location information from GPS is transmitted to the flow control server 106, which uses it with a survey information database 1204 to infer the location of the electric resource 112.

[0155] The exemplary method 1200 includes acquiring (1206) the noisy position data; communicating (1208) the acquired noisy position data to the flow control server 106; and inferring (1210) the location using the stored survey information and the acquired data.

#### Exemplary Transaction Methods and Business Methods

[0156] The exemplary power aggregation system 100 supports the following functions and interactions:

[0157] 1. Setup—The power aggregation system 100 creates contracts outside the system and/or bids into open markets to procure contracts for power services contracts via the web server 718 and contract manager 720. The system 100 then resolves these requests into specific power requirements upon dispatch from the grid operator 404, and communicates these requirements to vehicle owners 408 by one of several communication techniques.

[0158] 2. Delivery—The grid interaction manager 712 accepts real-time grid control signals 714 from grid operators 404 through a power-delivery device, and responds to these signals 714 by delivering power services from connected electric vehicles 200 to the grid 114.

[0159] 3. Reporting—After a power delivery event is complete, a transaction manager can report power services transactions stored in the database 716. A billing manager resolves these requests into specific credit or debit billing transactions. These transactions may be communicated to a grid operator's or utility's billing system for account reconciliation. The transactions may also be used to make payments directly to resource owners 408.

[0160] In one implementation, the vehicle-resident remote IPF module 134 may include a communications manager to receive offers to provide power services, display them to the user and allow the user to respond to offers. Sometimes this type of advertising or contracting interaction can be carried out by the electric resource owner 408 conventionally connecting with the web server 718 of the flow control server 106.

[0161] In an exemplary business model of managing vehicle-based load or storage, the exemplary power aggregation system 100 serves as an intermediary between vehicle owners 408 (individuals, fleets, etc.) and grid operators 404 (Independent System Operators (ISOs), Regional Transmission Operators (RTOs), utilities, etc.).

[0162] The load and storage electric resource 112 presented by a single plug-in electric vehicle 200 is not a substantial enough resource for an ISO or utility to consider controlling directly. However, by aggregating many electric vehicles 200 together, managing their load behavior, and exporting a

simple control interface, the power aggregation system 100 provides services that are valuable to grid operators 404.

[0163] Likewise, vehicle owners 408 may not be interested in participating without participation being made easy, and without there being incentive to do so. By creating value through aggregated management, the power aggregation system 100 can provide incentives to owners in the form of payments, reduced charging costs, etc. The power aggregation system 100 can also make the control of vehicle charging and uploading power to the grid 114 automatic and nearly seamless to the vehicle owner 408, thereby making participation palatable.

[0164] By placing remote IPF modules 134 in electric vehicles 200 that can measure attributes of power quality, the power aggregation system 100 enables a massively distributed sensor network for the power distribution grid 114. Attributes of power quality that the power aggregation system 100 can measure include frequency, voltage, power factor, harmonics, etc. Then, leveraging the communication infrastructure of the power aggregation system 100, including remote IPF modules 134, this sensed data can be reported in real time to the flow control server 106, where information is aggregated. Also, the information can be presented to the utility, or the power aggregation system 100 can directly correct undesirable grid conditions by controlling vehicle charge/power upload behavior of numerous electric vehicles 200, changing the load power factor, etc.

[0165] The exemplary power aggregation system 100 can also provide Uninterruptible Power Supply (UPS) or backup power for a home/business, including interconnecting islanding circuitry. In one implementation, the power aggregation system 100 allows electric resources 112 to flow power out of their batteries to the home (or business) to power some or all of the home's loads. Certain loads may be configured as key loads to keep "on" during a grid power-loss event. In such a scenario, it is important to manage islanding of the residence 124 from the grid 114. Such a system may include anti-islanding circuitry that has the ability to communicate with the electric vehicle 200, described further below as a smart breaker box. The ability of the remote IPF module 134 to communicate allows the electric vehicle 200 to know if providing power is safe, "safe" being defined as "safe for utility line workers as a result of the main breaker of the home being in a disconnected state." If grid power drops, the smart breaker box disconnects from the grid and then contacts any electric vehicles 200 or other electric resources 112 participating locally, and requests them to start providing power. When grid power returns, the smart breaker box turns off the local power sources, and then reconnects.

[0166] For mobile billing (for when the vehicle owner 408 is different than the meter account owner 410), there are two important aspects for the billing manager to reckon with during electric vehicle recharging: who owns the vehicle, and who owns the meter account of the facility where recharge is happening. When the vehicle owner 408 is different than the meter account owner 410, there are several options:

[0167] 1. The meter owner 410 may give free charging.

[0168] 2. The vehicle owner 408 may pay at the time of charging (via credit card, account, etc.)

[0169] 3. A pre-established account may be settled automatically.

[0170] Without oversight of the power aggregation system 100, theft of services may occur. With automatic account settling, the power aggregation system 100 records when



electric vehicles **200** charge at locations that require payment, via vehicle IDs and location IDs, and via exemplary metering of time-annotated energy flow in/out of the vehicle. In these cases, the vehicle owner **408** is billed for energy used, and that energy is not charged to the facility's meter account owner **410** (so double-billing is avoided). A billing manager that performs automatic account settling can be integrated with the power utility, or can be implemented as a separate debit/credit system.

[0171] An electrical charging station, whether free or for pay, can be installed with a user interface that presents useful information to the user. Specifically, by collecting information about the grid **114**, the vehicle state, and the preferences of the user, the station can present information such as the current electricity price, the estimated recharge cost, the estimated time until recharge, the estimated payment for uploading power to the grid **114** (either total or per hour), etc. The information acquisition engine **414** communicates with the electric vehicle **20** and with public and/or private data networks **722** to acquire the data used in calculating this information.

[0172] The exemplary power aggregation system **100** also offers other features for the benefit of electric resource owners **408** (such as vehicle owners):

[0173] vehicle owners can earn free electricity for vehicle charging in return for participating in the system;

[0174] vehicle owners can experience reduced charging cost by avoiding peak time rates;

[0175] vehicle owners can receive payments based on the actual energy service their vehicle provides;

[0176] vehicle owners can receive a preferential tariff for participating in the system.

[0177] There are also features between the exemplary power aggregation system **100** and grid operators **404**:

[0178] the power aggregation system **100** as electric resource aggregator can earn a management fee (which may be some function of services provided), paid by the grid operator **404**.

[0179] the power aggregation system **100** as electric resource aggregator can sell into power markets **412**;

[0180] grid operators **404** may pay for the power aggregation system **100**, but operate the power aggregation system **100** themselves.

#### Exemplary Safety and Remote Smart-Islanding

[0181] The exemplary power aggregation system **100** can include methods and components for implementing safety standards and safely actuating energy discharge operations. For example, the exemplary power aggregation system **100** may use in-vehicle line sensors as well as smart-islanding equipment installed at particular locations. Thus, the power aggregation system **100** enables safe vehicle-to-grid operations. Additionally, the power aggregation system **100** enables automatic coordination of resources for backup power scenarios.

[0182] In one implementation, an electric vehicle **200** containing a remote IPF module **134** stops vehicle-to-grid upload of power if the remote IPF module **134** senses no line power originating from the grid **114**. This halting of power upload prevents electrifying a cord that may be unplugged, or electrifying a powerline **206** that is being repaired, etc. However, this does not preclude using the electric vehicle **200** to provide

backup power if grid power is down because the safety measures described below ensure that an island condition is not created.

[0183] Additional smart-islanding equipment installed at a charging location can communicate with the remote IPF module **134** of an electric vehicle **200** to coordinate activation of power upload to the grid **114** if grid power drops. One particular implementation of this technology is a vehicle-to-home backup power capability.

[0184] FIG. 13 shows exemplary safety measures in a vehicle-to-home scenario, in which an electric resource **112** is used to provide power to a load or set of loads (as in a home). A breaker box **1300** is connected to the utility electric meter **1302**. When an electric resource **112** is flowing power into the grid (or local loads), an islanding condition should be avoided for safety reasons. The electric resource **112** should not energize a line that would conventionally be considered de-energized in a power outage by line workers.

[0185] A locally installed smart grid disconnect (switch) **1304** senses the utility line in order to detect a power outage condition and coordinates with the electric resource **112** to enable vehicle-to-home power transfer. In the case of a power outage, the smart grid disconnect **1304** disconnects the circuit breakers **1306** from the utility grid **114** and communicates with the electric resource **112** to begin power backup services. When the utility services return to operation, the smart grid disconnect **1304** communicates with the electric resource **112** to disable the backup services and reconnect the breakers to the utility grid **114**.

[0186] FIG. 14 shows exemplary safety measures when multiple electric resources **112** power a home. In this case, the smart grid disconnect **1304** coordinates with all connected electric resources **112**. One electric resource **112** is deemed the "master" **1400** for purposes of generating a reference signal **1402** and the other resources are deemed "slaves" **1404** and follow the reference of the master **1400**. In a case in which the master **1400** disappears from the network, the smart grid disconnect **1304** assigns another slave **1404** to be the reference/master **1400**.

[0187] FIG. 15 shows the smart grid disconnect **1304** of FIGS. 13 and 14, in greater detail. In one implementation, the smart grid disconnect **1304** includes a processor **1502**, a communicator **1504** coupled with connected electric resources **112**, a voltages sensor **1506** capable of sensing both the internal and utility-side AC lines, a battery **1508** for operation during power outage conditions, and a battery charger **1510** for maintaining the charge level of the battery **1508**. A controlled breaker or relay **1512** switches between grid power and electric resource-provided power when signaled by the processor **1502**.

#### Exemplary User Experience Options

[0188] The exemplary power aggregation system **100** can enable a number of desirable user features:

[0189] data collection can include distance driven and both electrical and non-electrical fuel usage, to allow derivation and analysis of overall vehicle efficiency (in terms of energy, expense, environmental impact, etc.). This data is exported to the flow control server **106** for storage **716**, as well as for display on an in-vehicle user interface, charging station user interface, and web/cell phone user interface.



[0190] intelligent charging learns the vehicle behavior and adapts the charging timing automatically. The vehicle owner 408 can override and request immediate charging if desired.

#### Exemplary Methods

[0191] FIG. 16 shows an exemplary method 1600 of power aggregation. In the flow diagram, the operations are summarized in individual blocks. The exemplary method 1600 may be performed by hardware, software, or combinations of hardware, software, firmware, etc., for example, by components of the exemplary power aggregation system 100.

[0192] At block 1602, communication is established with each of multiple electric resources connected to a power grid. For example, a central flow control service can manage numerous intermittent connections with mobile electric vehicles, each of which may connect to the power grid at various locations. An in-vehicle remote agent connects each vehicle to the Internet when the vehicle connects to the power grid.

[0193] At block 1604, the electric resources are individually signaled to provide power to or take power from the power grid.

[0194] FIG. 17 is a flow diagram of an exemplary method of communicatively controlling an electric resource for power aggregation. In the flow diagram, the operations are summarized in individual blocks. The exemplary method 1700 may be performed by hardware, software, or combinations of hardware, software, firmware, etc., for example, by components of the exemplary intelligent power flow (IPF) module 134.

[0195] At block 1702, communication is established between an electric resource and a service for aggregating power.

[0196] At block 1704, information associated with the electric resource is communicated to the service.

[0197] At block 1706, a control signal based in part upon the information is received from the service.

[0198] At block 1708, the resource is controlled, e.g., to provide power to the power grid or to take power from the grid, i.e., for storage.

[0199] At block 1710, bidirectional power flow of the electric device is measured, and used as part of the information associated with the electric resource that is communicated to the service at block 1704.

[0200] FIG. 18 is a flow diagram of an exemplary method of metering bidirectional power of an electric resource. In the flow diagram, the operations are summarized in individual blocks. The exemplary method 1800 may be performed by hardware, software, or combinations of hardware, software, firmware, etc., for example, by components of the exemplary power flow meter 824.

[0201] At block 1802, energy transfer between an electric resource and a power grid is measured bidirectionally.

[0202] At block 1804, the measurements are sent to a service that aggregates power based in part on the measurements.

[0203] FIG. 19 is a flow diagram of an exemplary method of determining an electric network location of an electric resource. In the flow diagram, the operations are summarized in individual blocks. The exemplary method 1900 may be performed by hardware, software, or combinations of hardware, software, firmware, etc., for example, by components of the exemplary power aggregation system 100.

[0204] At block 1902, physical location information is determined. The physical location information may be derived from such sources as GPS signals or from the relative strength of cell tower signals as an indicator of their location. Or, the physical location information may be derived by receiving a unique identifier associated with a nearby device, and finding the location associated with that unique identifier.

[0205] At block 1904, an electric network location, e.g., of an electric resource or its connection with the power grid, is determined from the physical location information.

[0206] FIG. 20 is a flow diagram of an exemplary method of scheduling power aggregation. In the flow diagram, the operations are summarized in individual blocks. The exemplary method 2000 may be performed by hardware, software, or combinations of hardware, software, firmware, etc., for example, by components of the exemplary flow control server 106.

[0207] At block 2002, constraints associated with individual electric resources are input.

[0208] At block 2004, power aggregation is scheduled, based on the input constraints.

[0209] FIG. 21 is a flow diagram of an exemplary method of smart islanding. In the flow diagram, the operations are summarized in individual blocks. The exemplary method 2100 may be performed by hardware, software, or combinations of hardware, software, firmware, etc., for example, by components of the exemplary power aggregation system 100.

[0210] At block 2102, a power outage is sensed.

[0211] At block 2104, a local connectivity—a network isolated from the power grid—is created.

[0212] At block 2106, local energy storage resources are signaled to power the local connectivity.

[0213] FIG. 22 is a flow diagram of an exemplary method of extending a user interface for power aggregation. In the flow diagram, the operations are summarized in individual blocks. The exemplary method 2200 may be performed by hardware, software, or combinations of hardware, software, firmware, etc., for example, by components of the exemplary power aggregation system 100.

[0214] At block 2202, a user interface is associated with an electric resource. The user interface may be displayed in, on, or near an electric resource, such as an electric vehicle that includes an energy storage system, or the user interface may be displayed on a device associated with the owner of the electric resource, such as a cell phone or portable computer.

[0215] At block 2204, power aggregation preferences and constraints are input via the user interface. In other words, a user may control a degree of participation of the electric resource in a power aggregation scenario via the user interface. Or, the user may control the characteristics of such participation.

[0216] FIG. 23 is a flow diagram of an exemplary method of gaining and maintaining electric vehicle owners in a power aggregation system. In the flow diagram, the operations are summarized in individual blocks. The exemplary method 2300 may be performed by hardware, software, or combinations of hardware, software, firmware, etc., for example, by components of the exemplary power aggregation system 100.

[0217] At block 2302, electric vehicle owners are enlisted into a power aggregation system for distributed electric resources.

[0218] At block 2304, an incentive is provided to each owner for participation in the power aggregation system.



[0219] At block 2306, recurring continued service to the power aggregation system is repeatedly compensated.

#### CONCLUSION

[0220] Although exemplary systems and methods have been described in language specific to structural features and/or methodological acts, it is to be understood that the subject matter defined in the appended claims is not necessarily limited to the specific features or acts described. Rather, the specific features and acts are disclosed as exemplary forms of implementing the claimed methods, devices, systems, etc.

The embodiments of the invention in which an exclusive property or privilege is claimed are defined as follows:

1. A method of determining an electric network location associated with a connection location of an electric vehicle, comprising:

obtaining physical location information, wherein the physical location information is associated with a physical charging location on a power grid; and

determining an electric network location of an electric resource from the physical location information, wherein the electric resource is an electric vehicle, wherein the electric network location of the electric resource is associated with a connection location for the electric resource on the power grid.

2. The method as recited in claim 1, wherein obtaining physical location information comprises receiving a unique identifier of a device and associating the unique identifier with a location of the device.

3. The method as recited in claim 2, wherein determining the electric network location includes associating the electric network location with the location of the device.

4. The method as recited in claim 1, wherein obtaining physical location information includes receiving a unique identifier associated with a device in a physical location in order to determine an electric network location of the electric resource connected to the electric network.

5. The method as recited in claim 4, further comprising sending the unique identifier to a service, wherein the service matches an electrical network location with the unique identifier.

6. The method as recited in claim 5, further comprising using the determined electrical network location for accurate control of aggregating power of multiple electric resources.

7. The method as recited in claim 5, wherein the service uses the determined electrical network location for a transaction associated with using or providing energy.

8. The method as recited in claim 2, wherein the device is selected from the group of devices consisting of a smart meter, a modem, a router, a network switch, a cable television set-top box, a TV remote, a garage door opener, an alarm system, an automotive satellite radio, a radio frequency identifier (RFID)-based unit, a cell phone tower, a cell phone, and a location identification beacon placed in the location with an associated location unique identifier.

9. The method as recited in claim 2, wherein the unique identifier comprises a media access control (MAC) address.

10. The method as recited in claim 9, wherein a service maps the MAC address to a location on the electrical network.

11. The method as recited in claim 5, wherein the device sends the unique ID back to a newly connected electric resource and the electric resource sends the unique identifier to the service.

12. The method as recited in claim 5, wherein the device sends the unique identifier and an identity of a newly connected electric resource to the service and the service determines the location of the newly connected electric resource.

13. The method as recited in claim 4, wherein the electric resource obtains the unique identifier via a wireless transmission or via a powerline carrier.

14. A method for approximating the location of an electric vehicle connected to an electric power grid, comprising:

acquiring a unique identifier and a signal strength from at least one wireless transceiver in proximity to an electric resource; wherein the electric resource is an electric vehicle; and

approximating a location of the electric resource by relating the signal strength to a distance between the electric resource and the corresponding wireless transceiver, wherein the location of the electric resource is associated with a connection location for the electric resource on an electric power grid.

15. The method as recited in claim 14, wherein the wireless transceivers comprise base stations of a GSM/UMTS wireless network, CDMA/CDMA2000 wireless network, a 802.16/WiMax wireless network, or an 802.11/WiFi wireless network.

16. The method as recited in claim 14, wherein the approximate location comprises an electricity account, an address, or a power grid control area.

17. The method as recited in claim 14, wherein the approximating uses one or more of past history of resource connection location, resource owner information such as home or work location, or querying the resource owner to confirm the resource location.

18. A method for determining an approximate location of an electric vehicle on an electric power grid, comprising:

acquiring global positioning satellite (GPS) signals at an electric resource; wherein the electric resource is an electric vehicle; and

inferring an approximate location of the electric resource on an electrical network by matching a GPS location with a map of the electrical network, wherein the approximate location of the electric resource is associated with a connection location of the electric resource on an electric power grid.

19. The method as recited in claim 18, wherein the approximate location comprises an electricity account, an address, or a power grid control area.

20. The method as recited in claim 18, wherein the inference uses one or more of past history of resource connection location, resource owner information such as home or work location, or querying the resource owner to confirm the resource location.

\* \* \* \* \*