



US 20110020701A1

(19) **United States**

(12) **Patent Application Publication**
Park et al.

(10) **Pub. No.: US 2011/0020701 A1**

(43) **Pub. Date: Jan. 27, 2011**

(54) **CARBON ELECTRODE STRUCTURES FOR BATTERIES**

(75) Inventors: **Benjamin Park**, Irvine, CA (US);
Alexander Gorkovenko, Mission Viejo, CA (US); **Rabih Zaouk**, Costa Mesa, CA (US); **William Schank**, Howell, MI (US)

Correspondence Address:
KNOBBE MARTENS OLSON & BEAR LLP
2040 MAIN STREET, FOURTEENTH FLOOR
IRVINE, CA 92614 (US)

(73) Assignee: **CARBON MICRO BATTERY CORPORATION**, Irvine, CA (US)

(21) Appl. No.: **12/838,368**

(22) Filed: **Jul. 16, 2010**

Related U.S. Application Data

(60) Provisional application No. 61/226,217, filed on Jul. 16, 2009, provisional application No. 61/295,993, filed on Jan. 18, 2010, provisional application No. 61/315,845, filed on Mar. 19, 2010.

Publication Classification

(51) **Int. Cl.**
H01M 10/0563 (2010.01)
H01M 4/583 (2010.01)

(52) **U.S. Cl.** **429/206; 429/231.8**

(57) **ABSTRACT**

In certain embodiments, an electrode includes a body of material formed in substantial part of carbon, the body having an exterior surface and an interior located within the exterior surface, and a plurality of cavities located in the interior of the body. Each of the cavities is in communication with the exterior of the body and has an interior surface. The cavities can each be sized to accommodate a battery separator located therein and substantially covering the interior surface of the cavity.

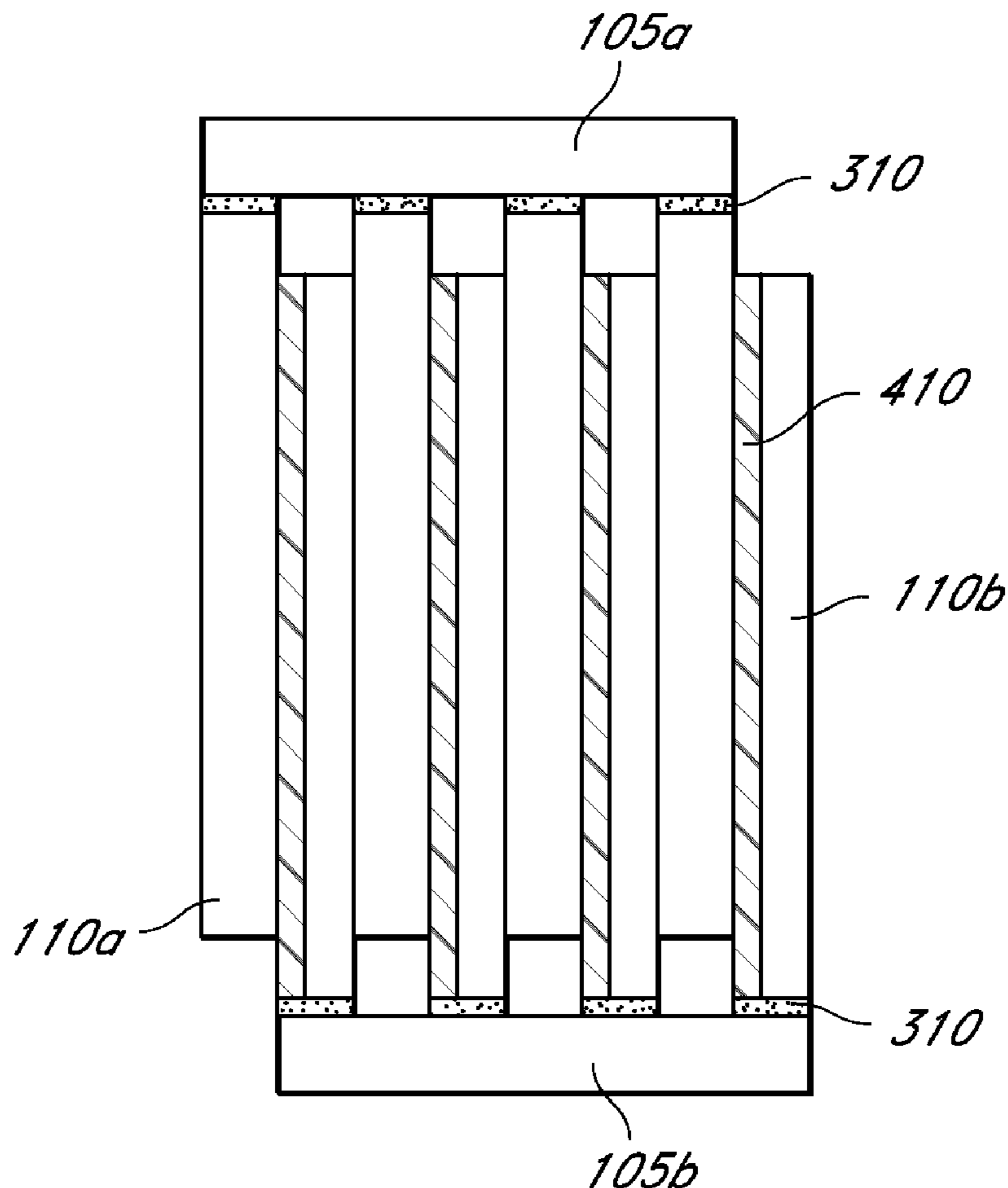

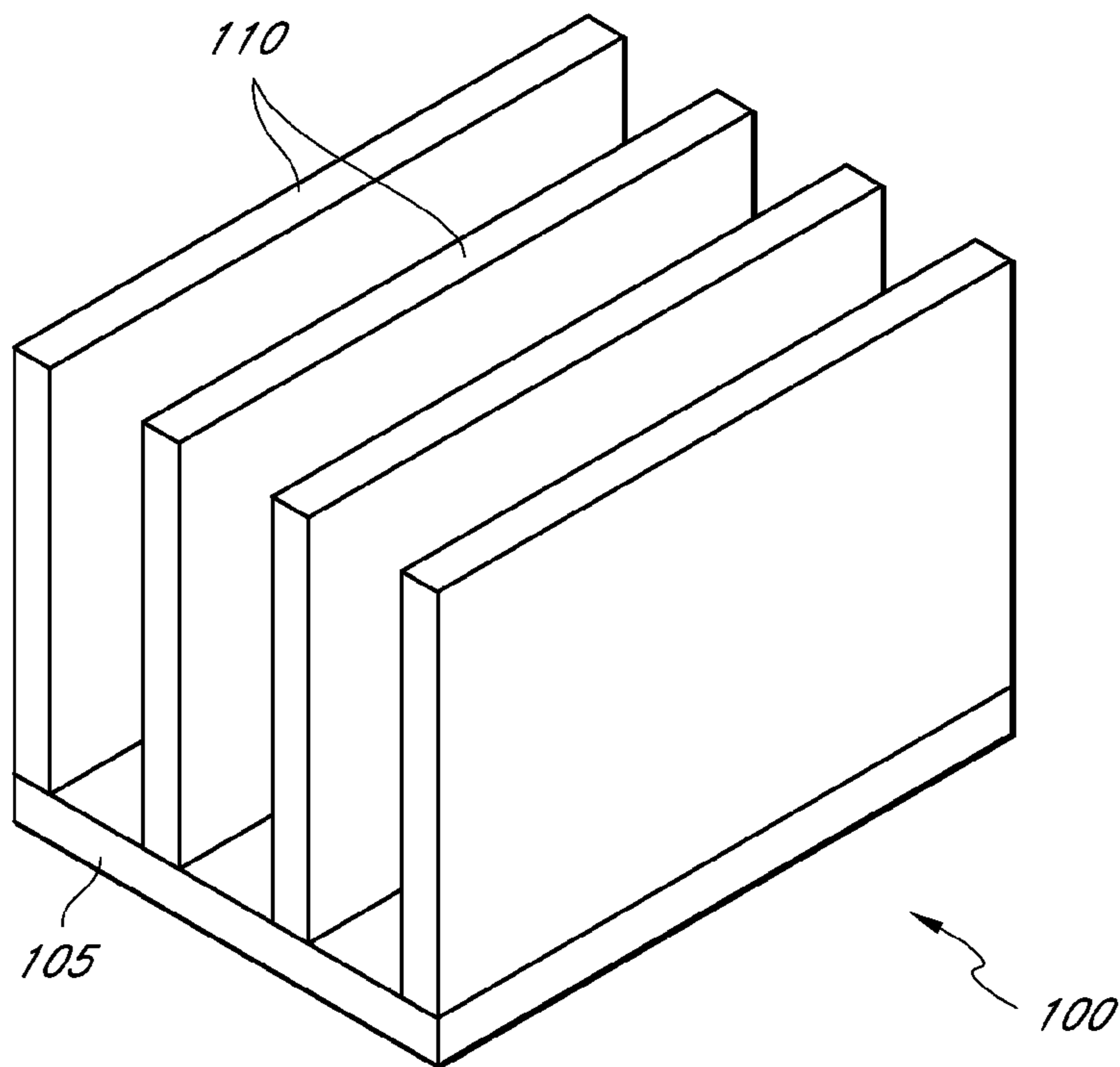

FIG. 1

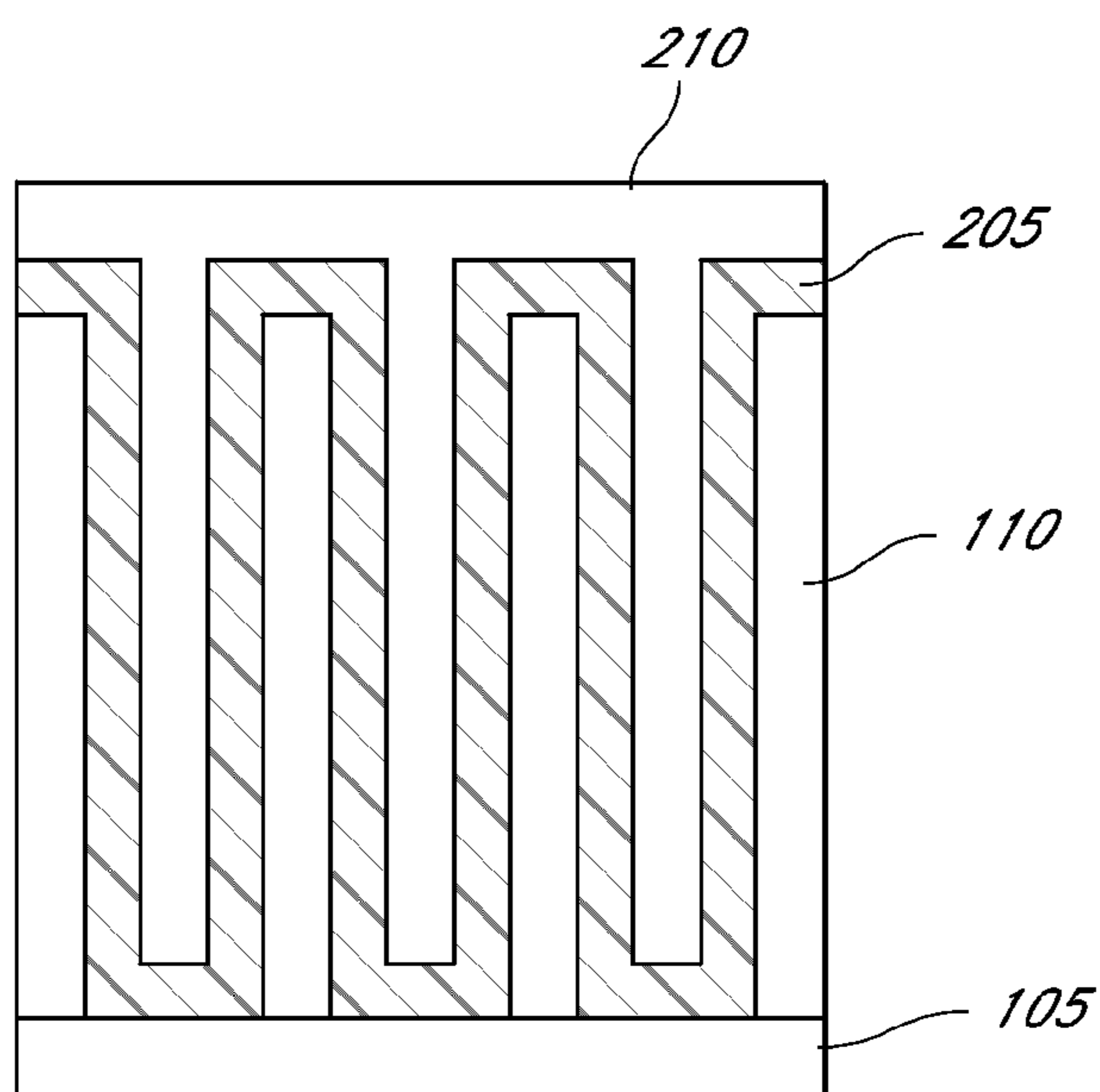

FIG. 2

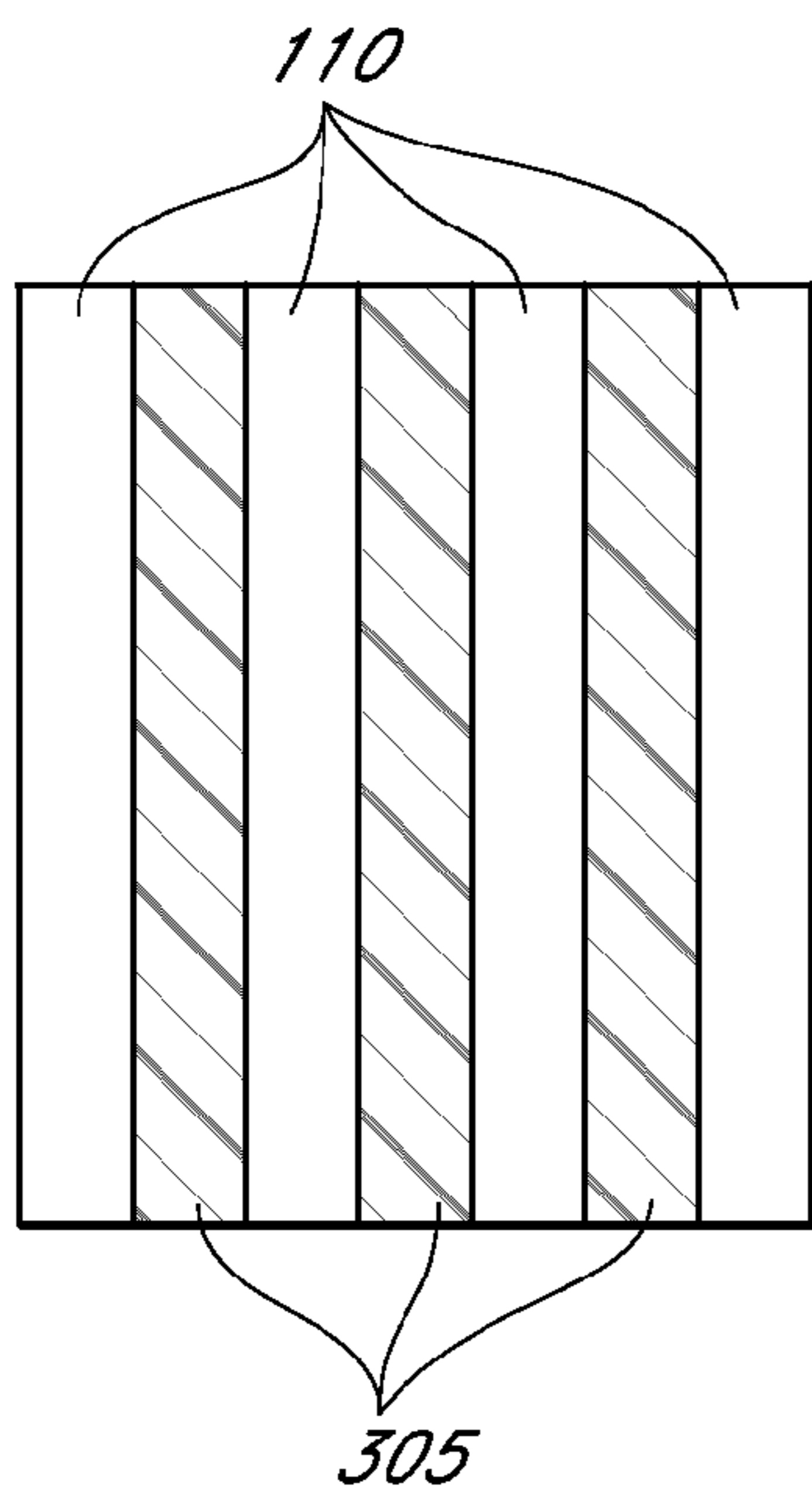

FIG. 3A

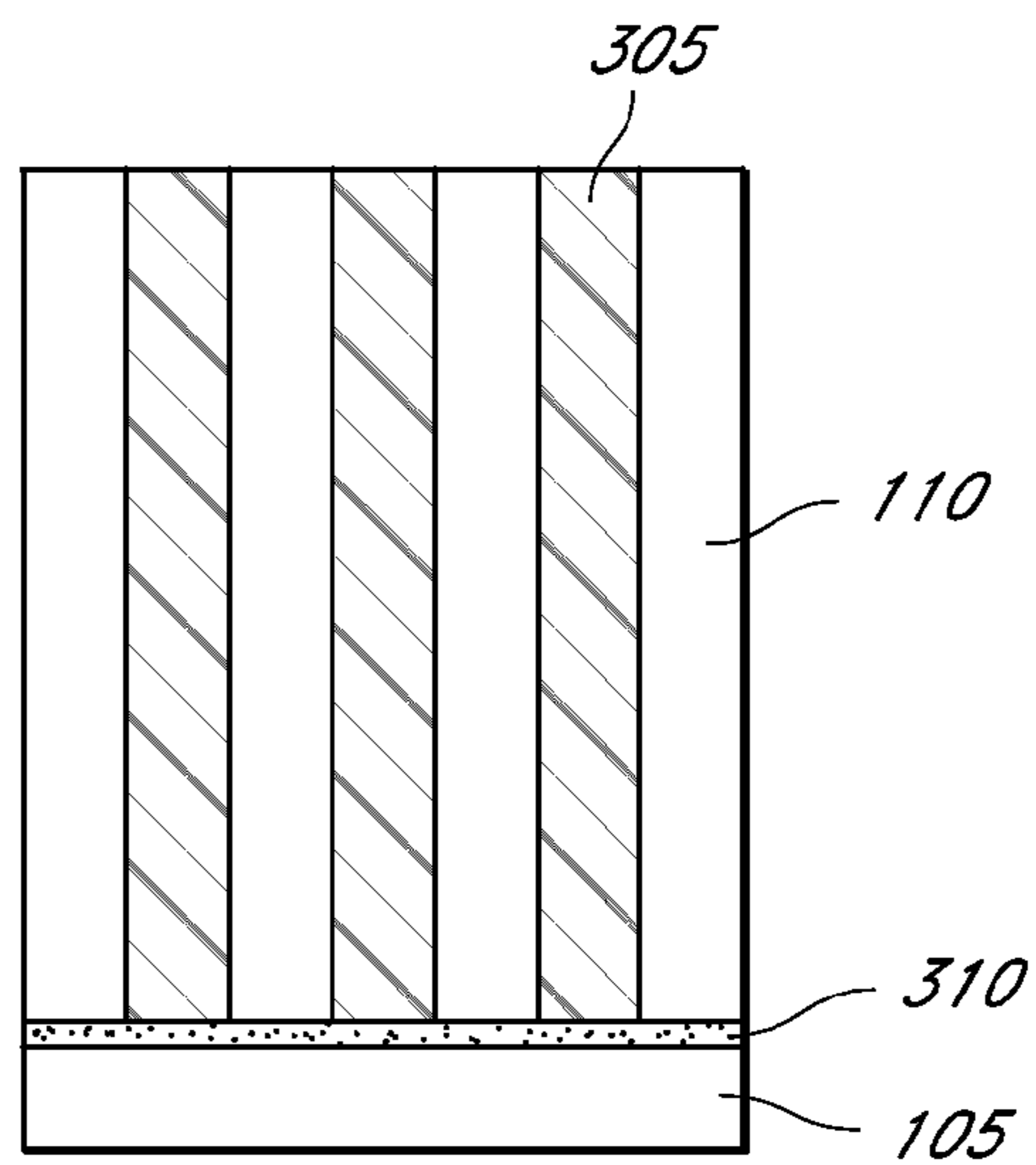

FIG. 3B

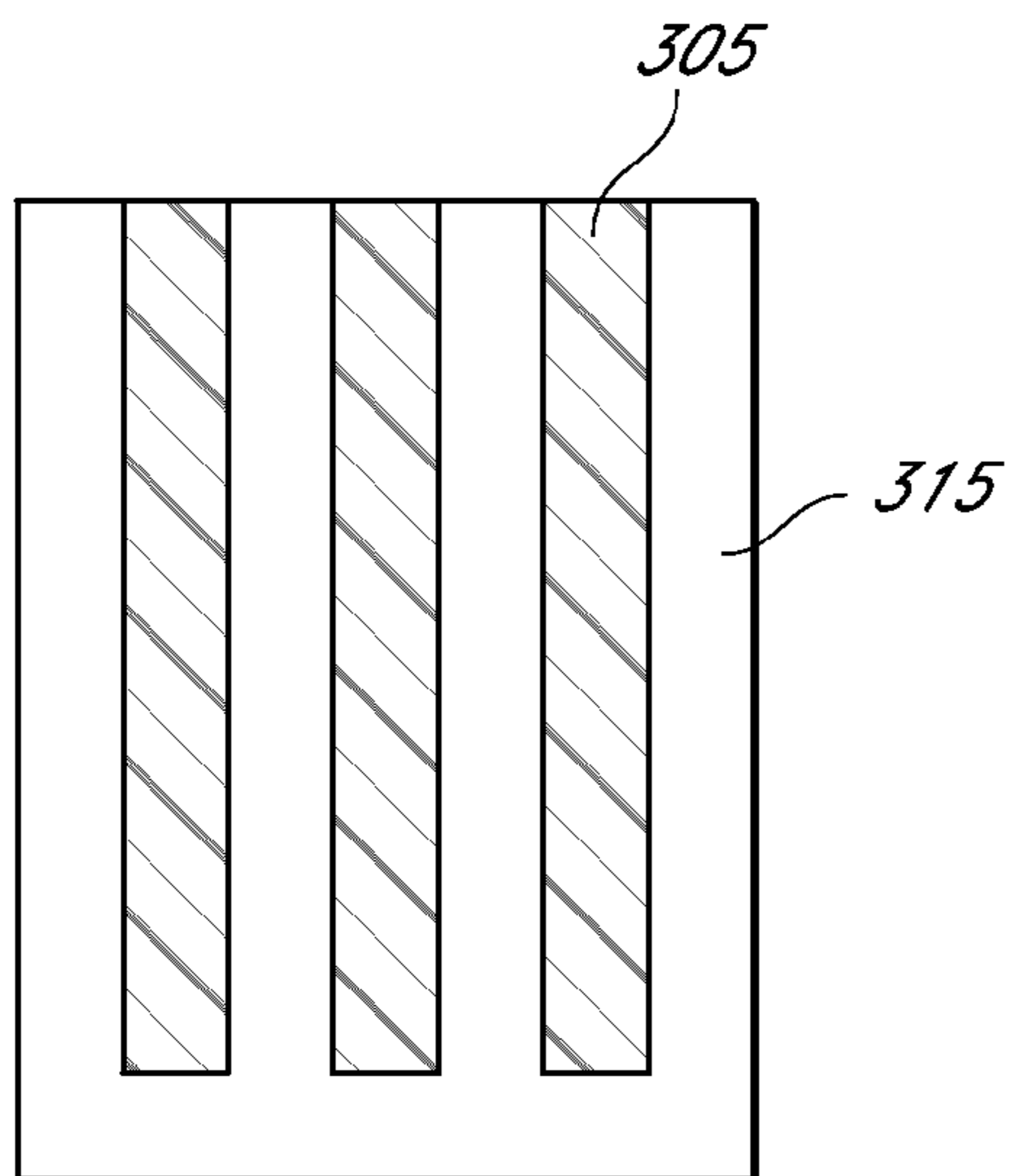

FIG. 3C

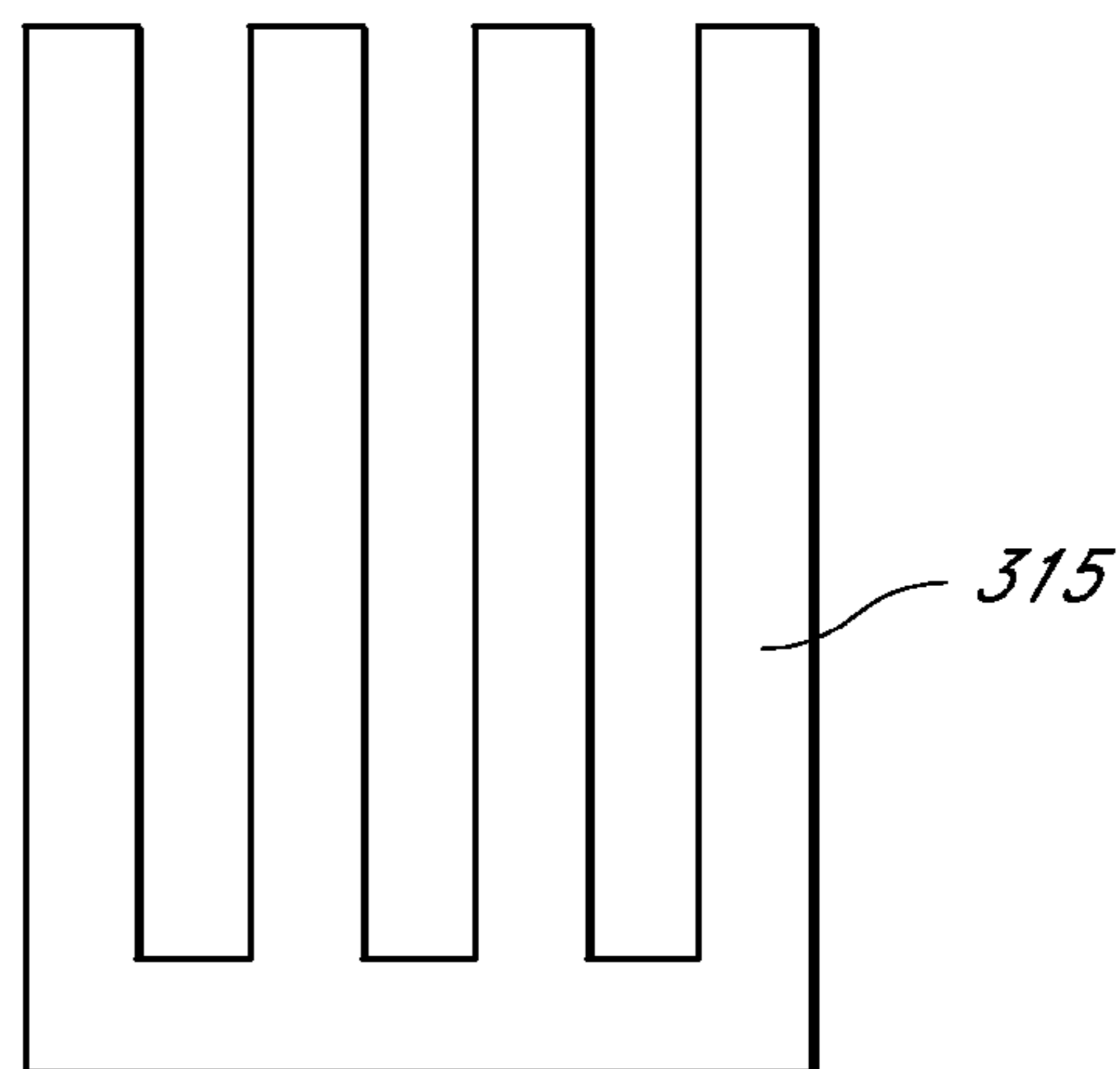

FIG. 3D

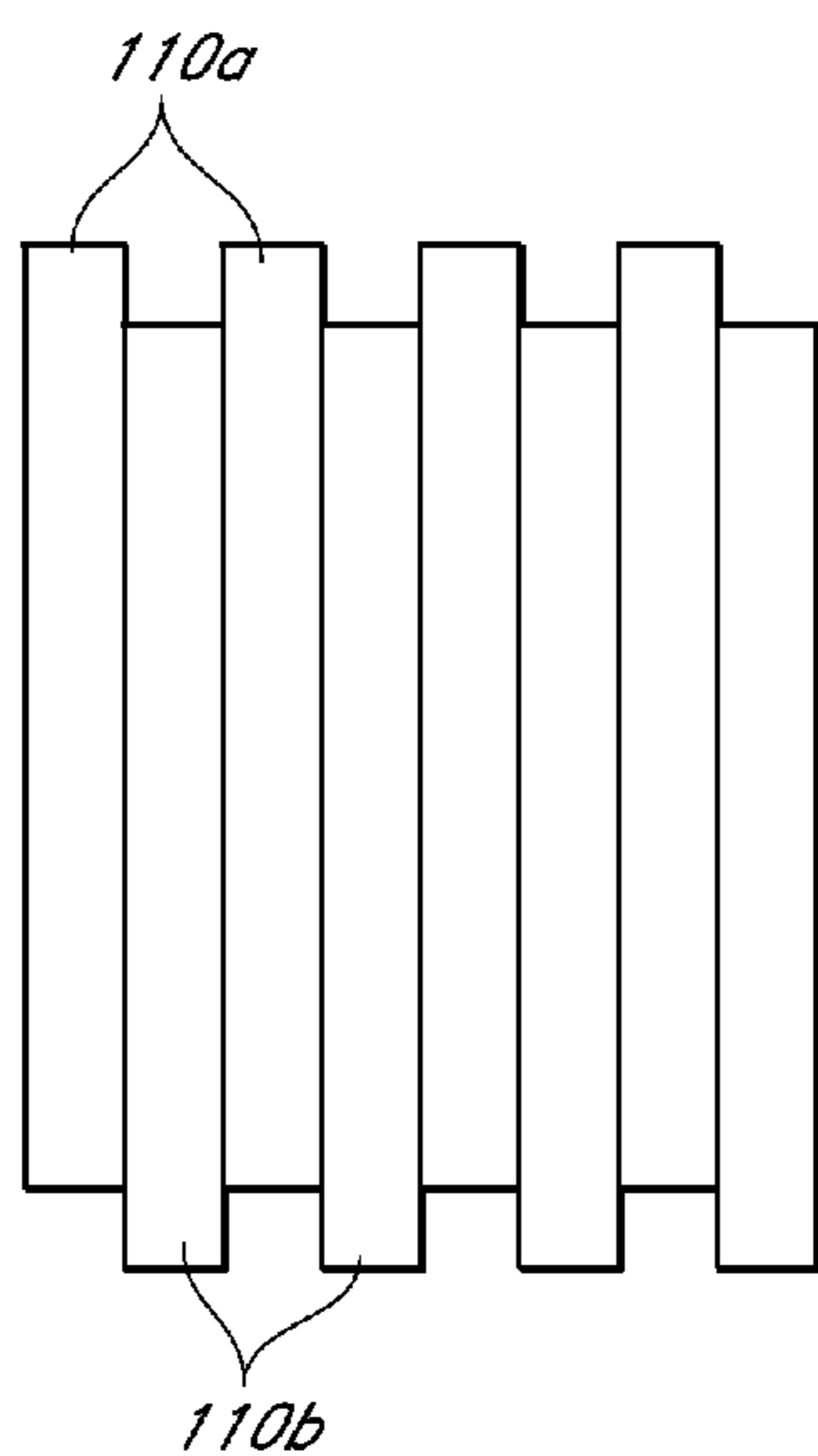

FIG. 4A

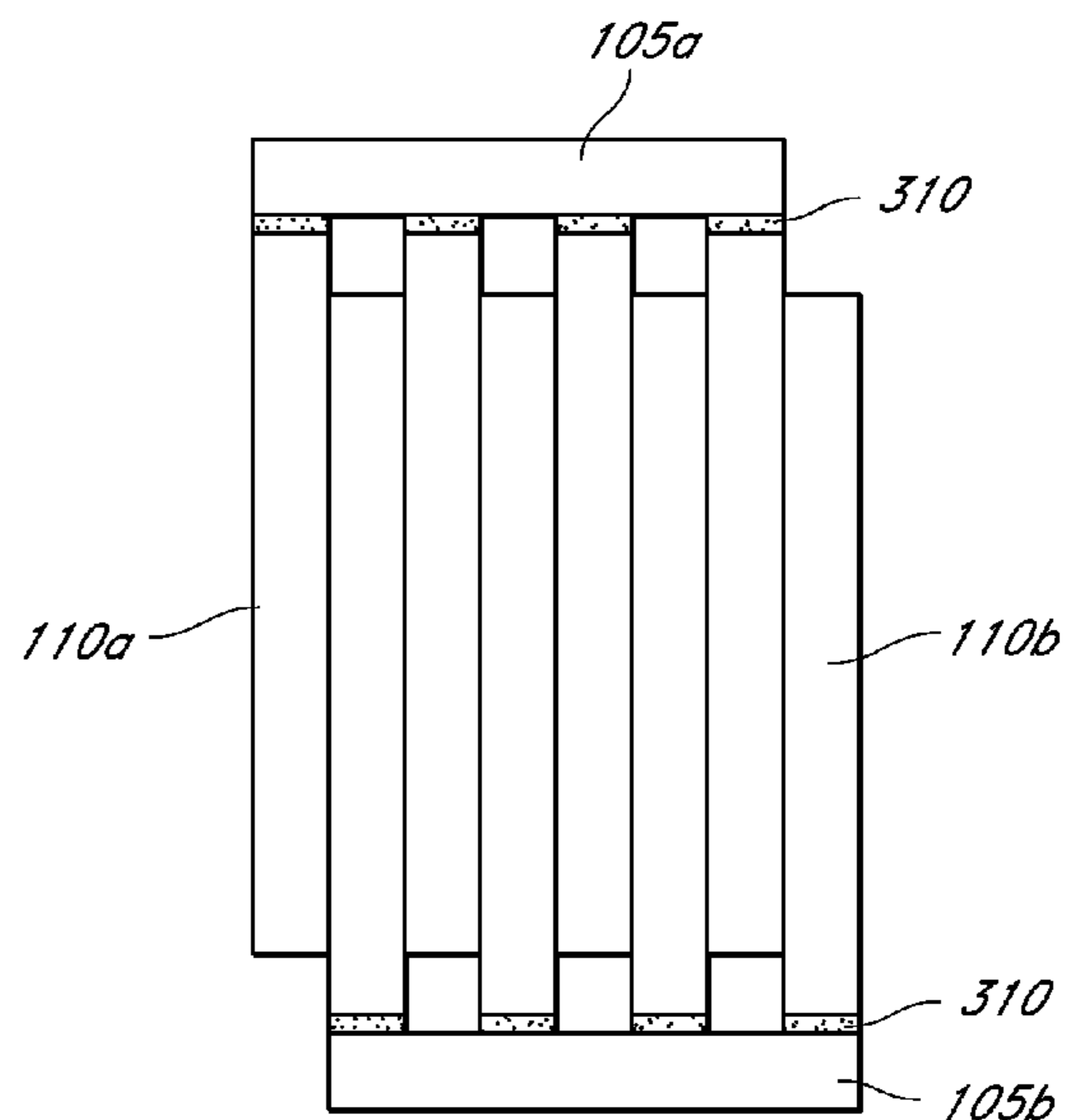

FIG. 4B

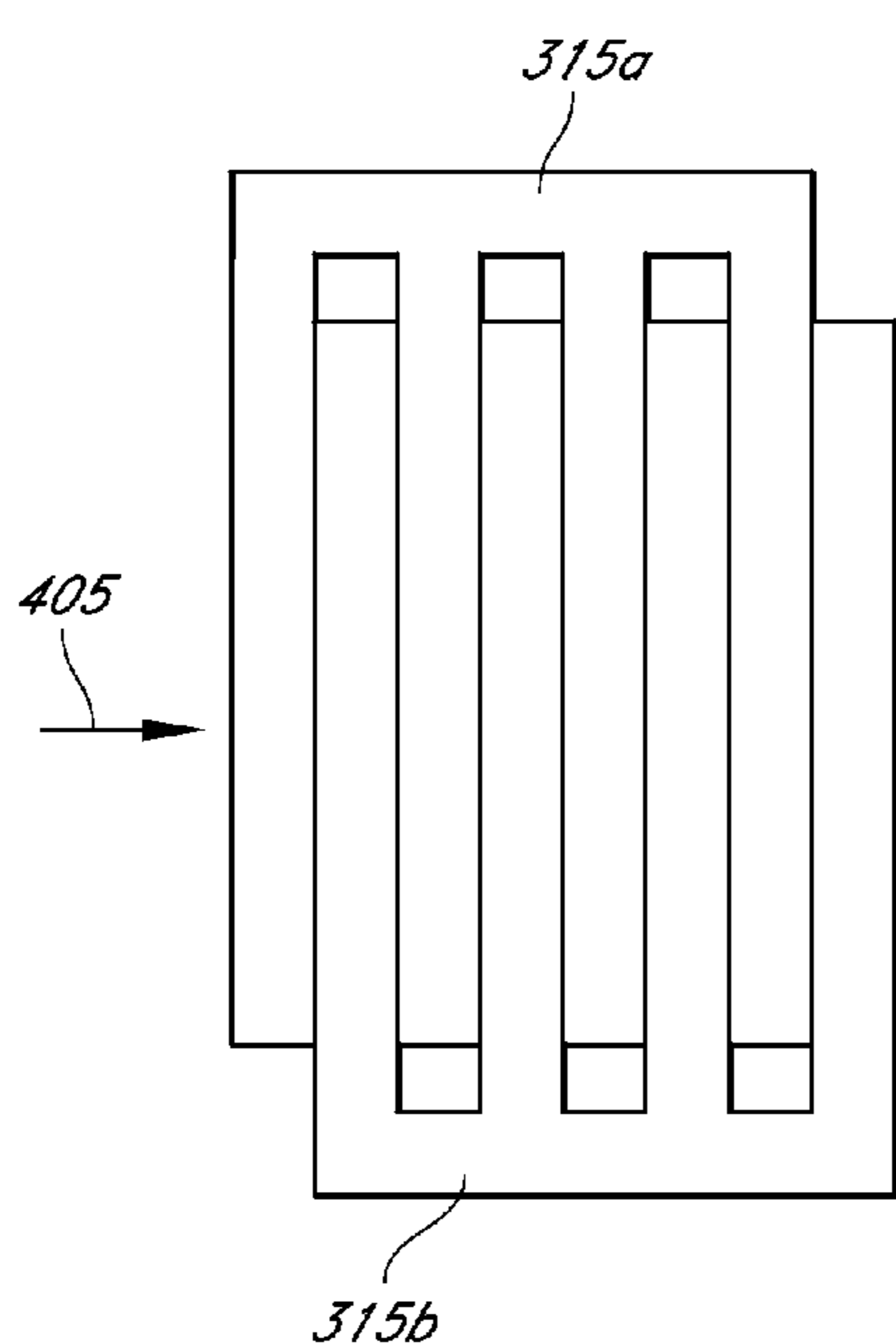

FIG. 4C

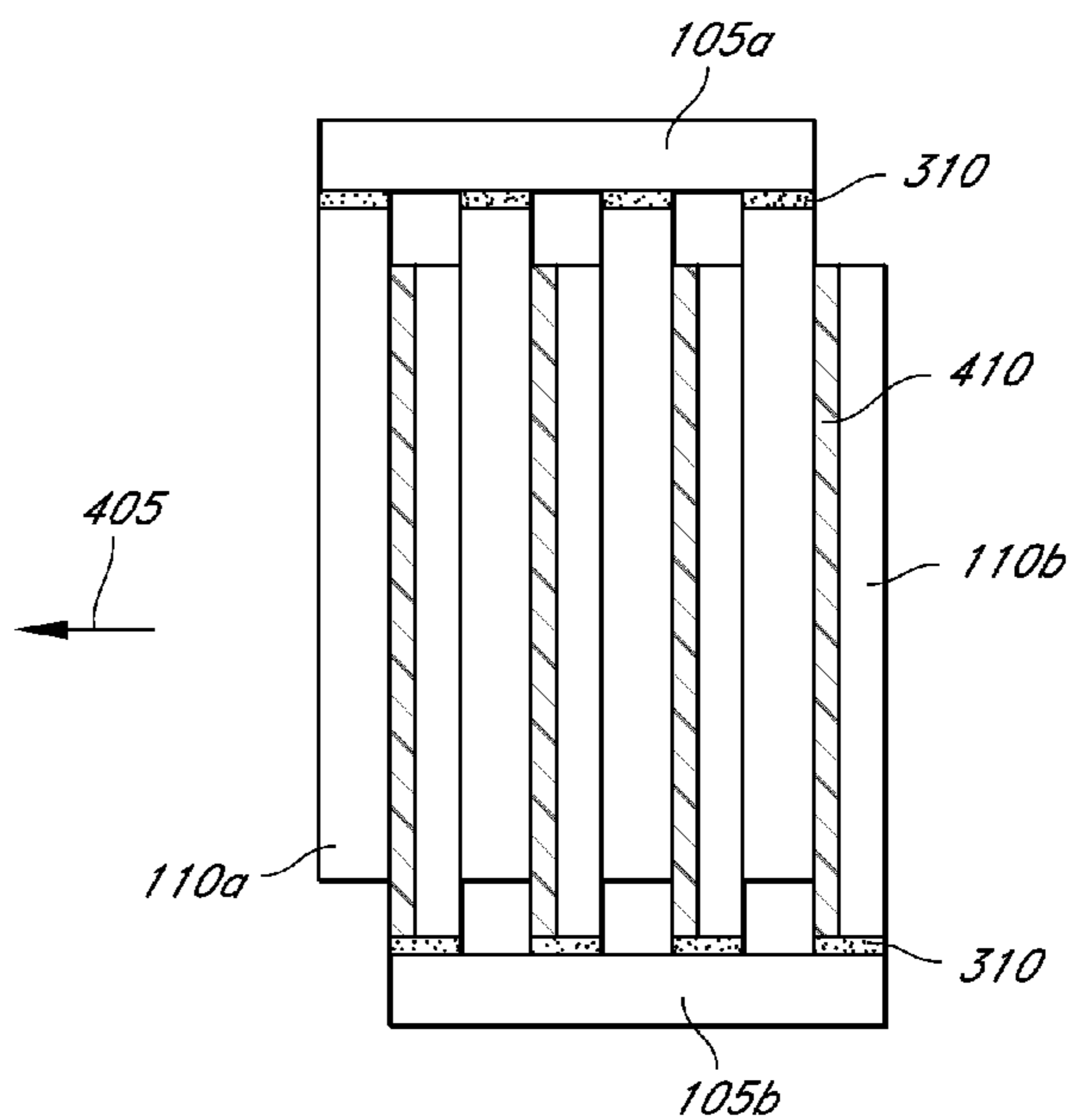
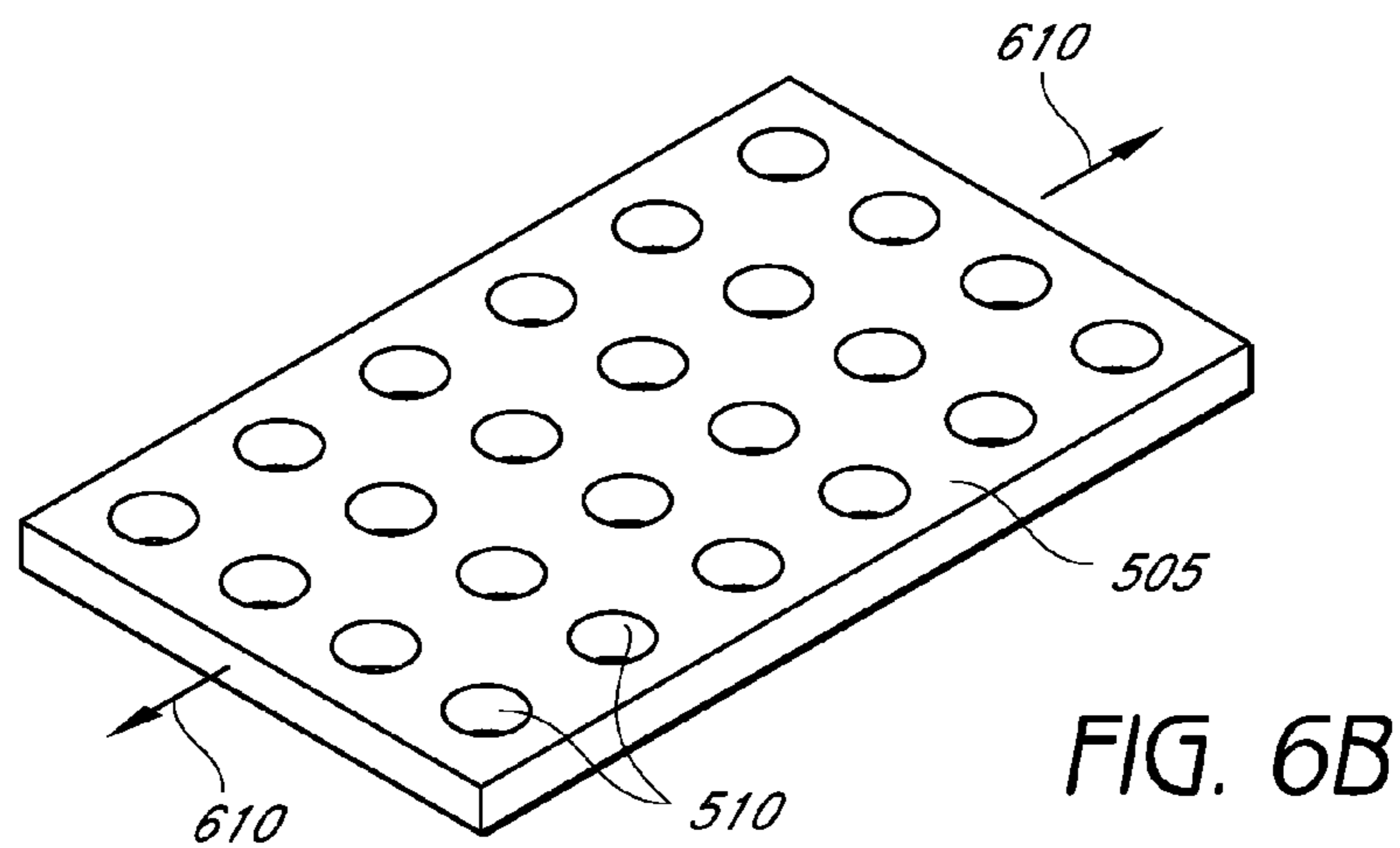
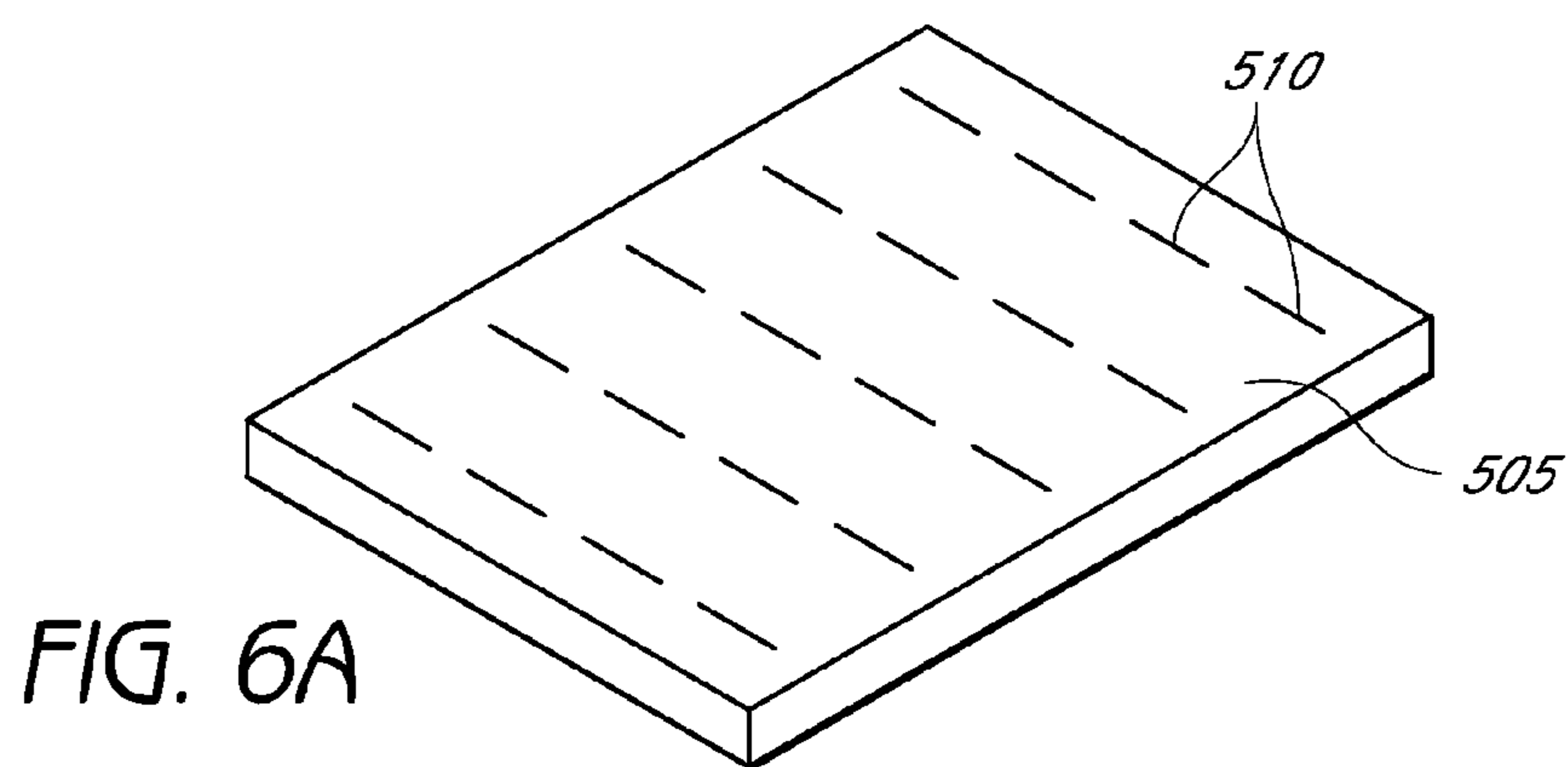
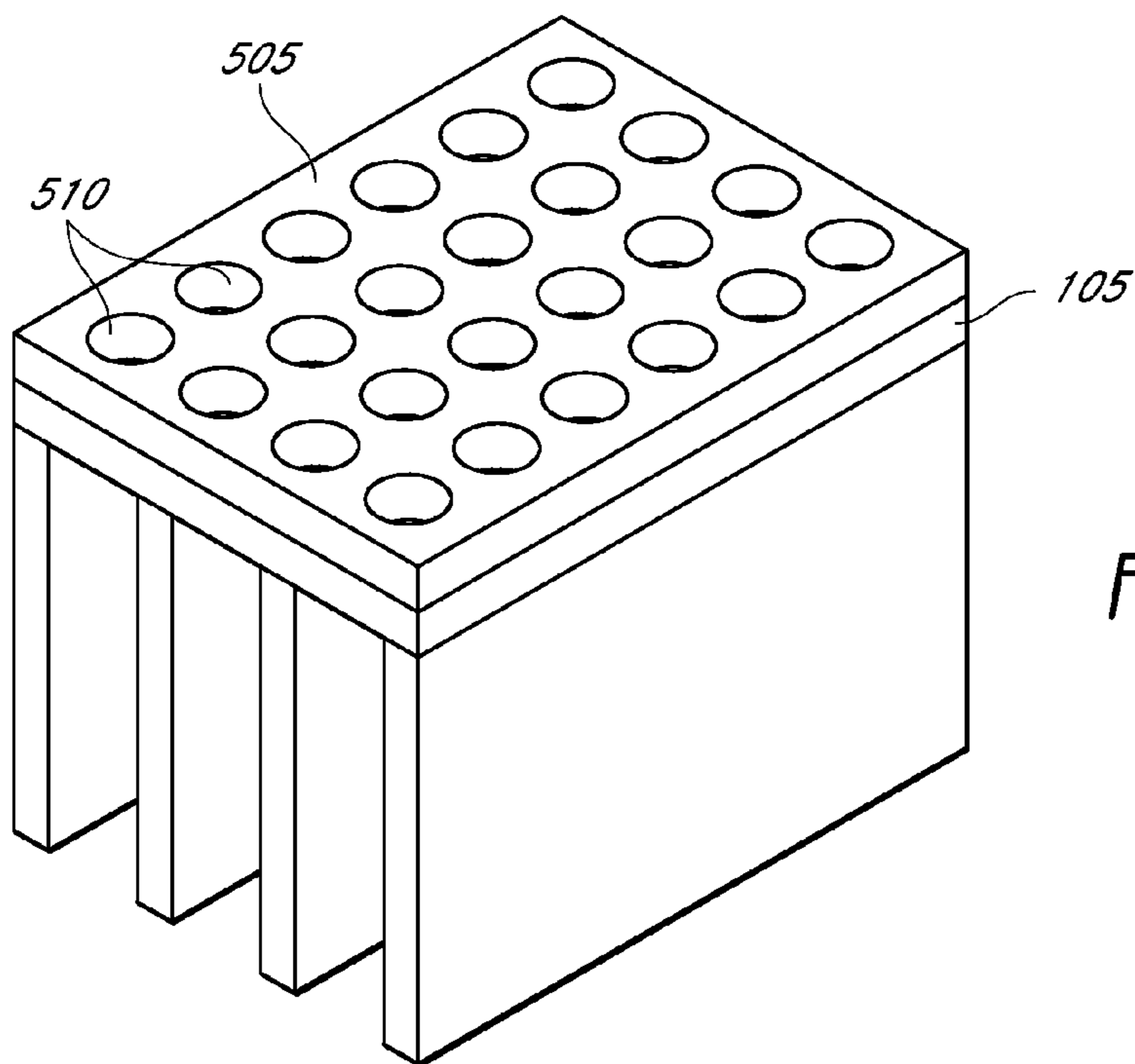

FIG. 4D



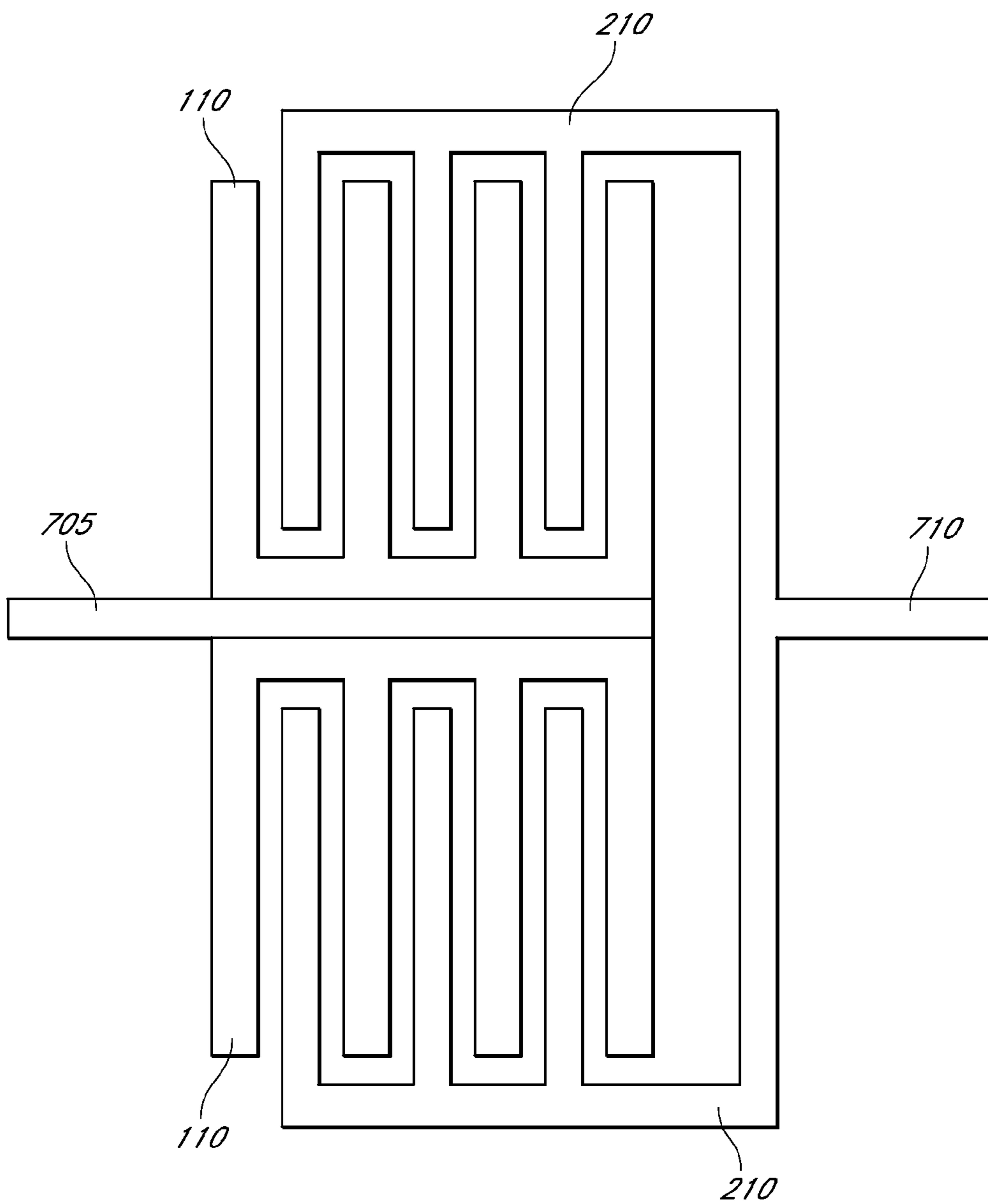

FIG. 7

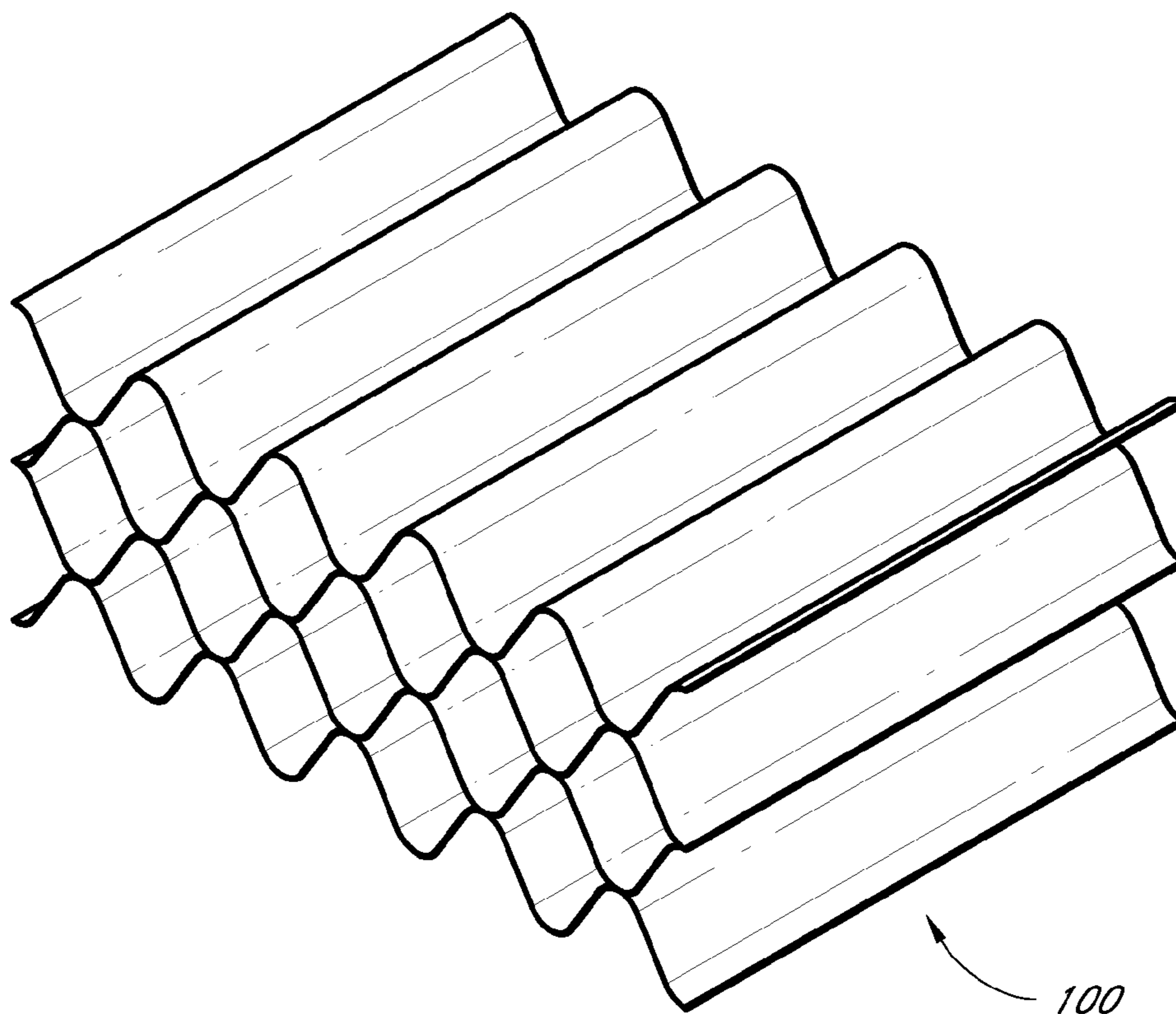

FIG. 8A

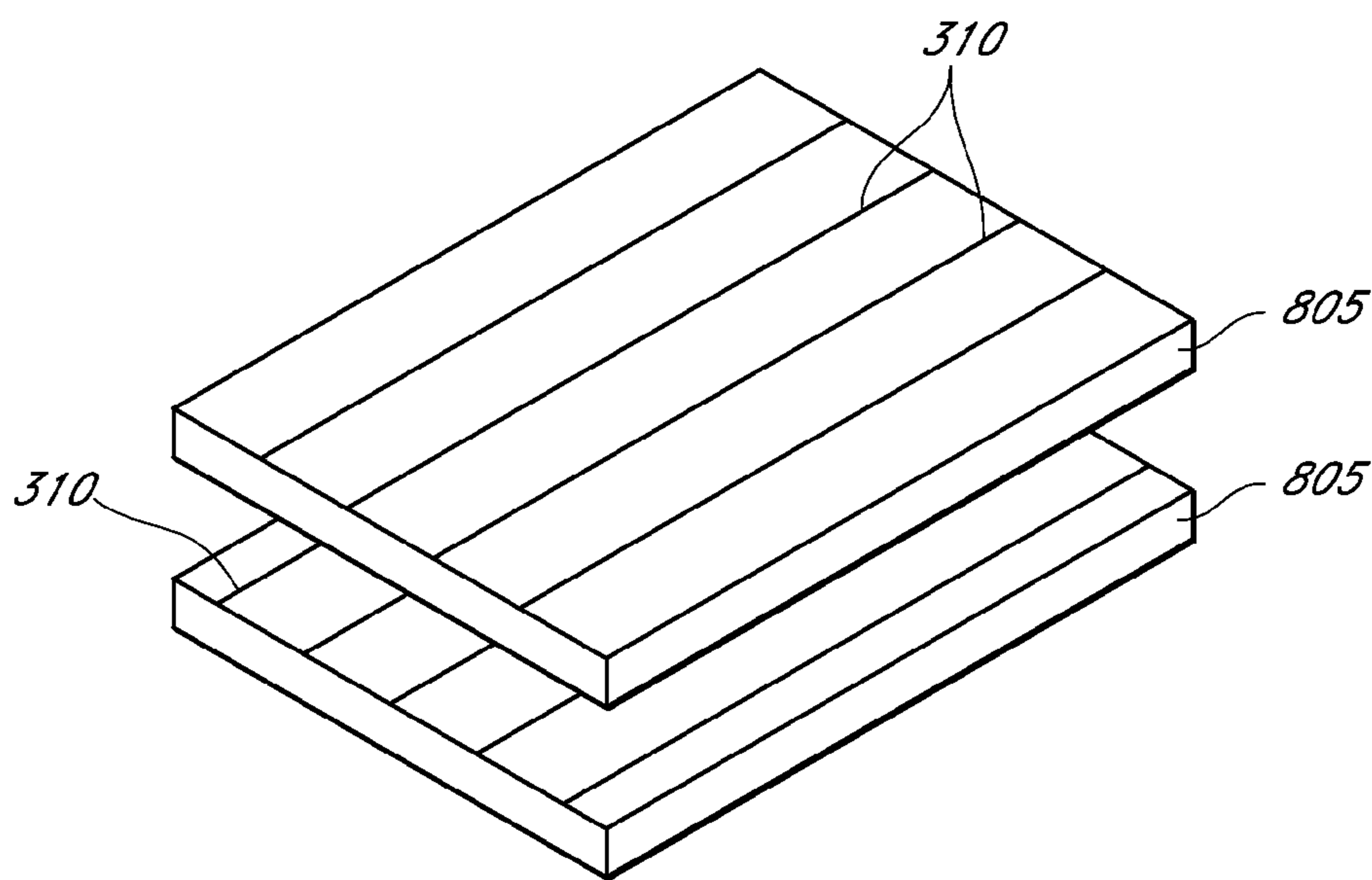

FIG. 8B

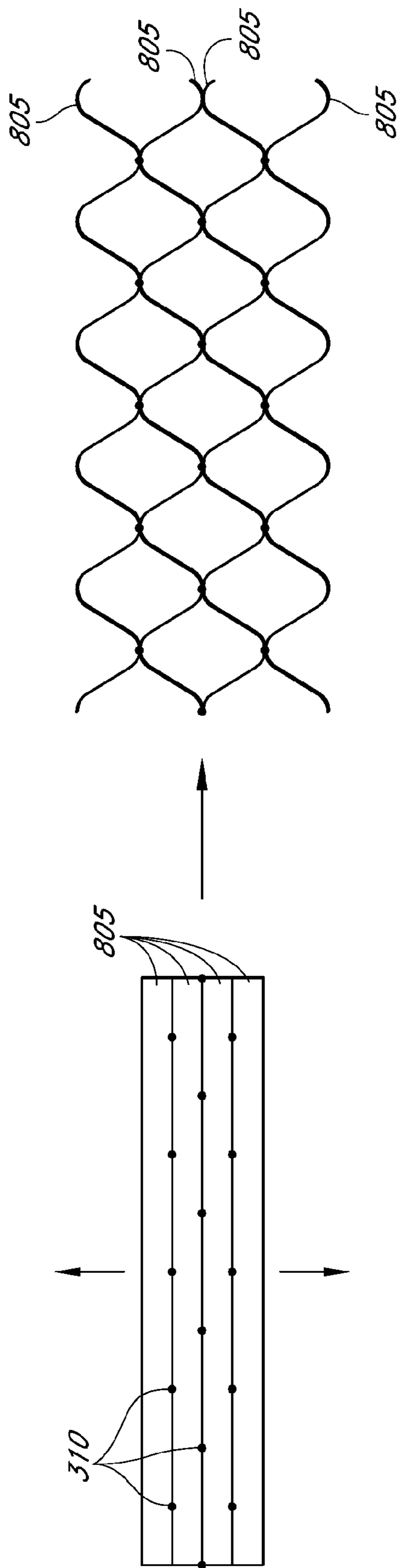

FIG. 8C

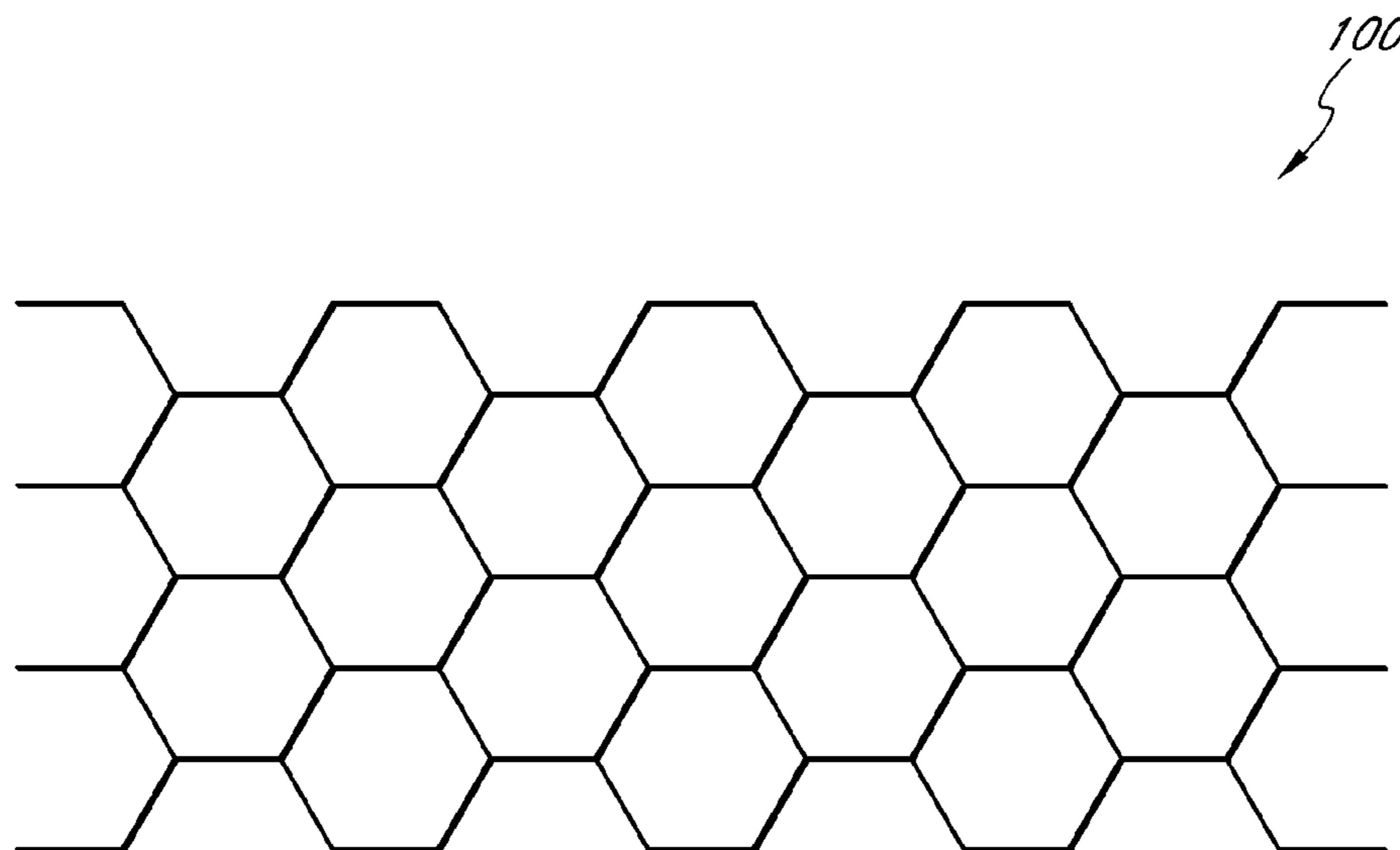

FIG. 9A

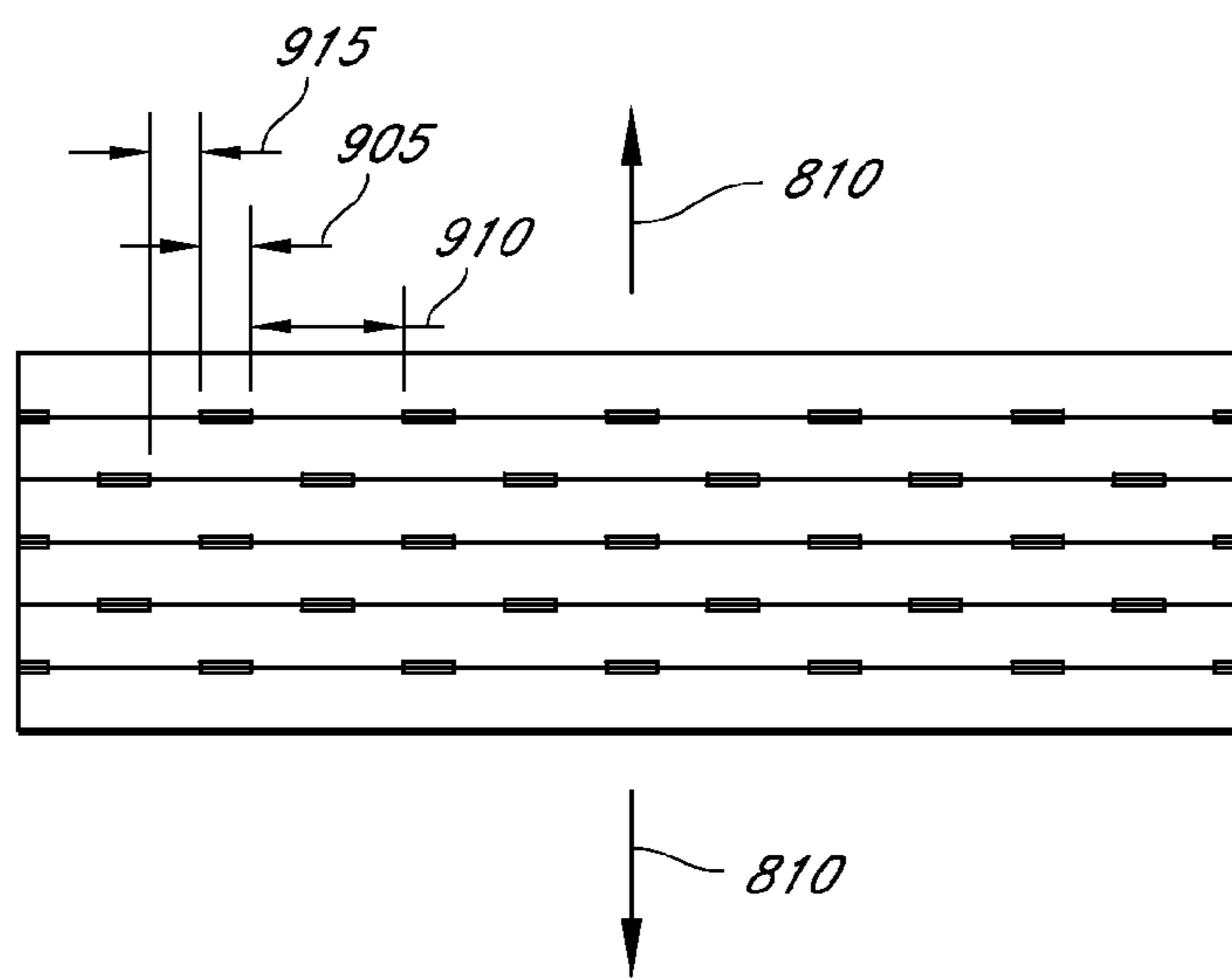

FIG. 9B

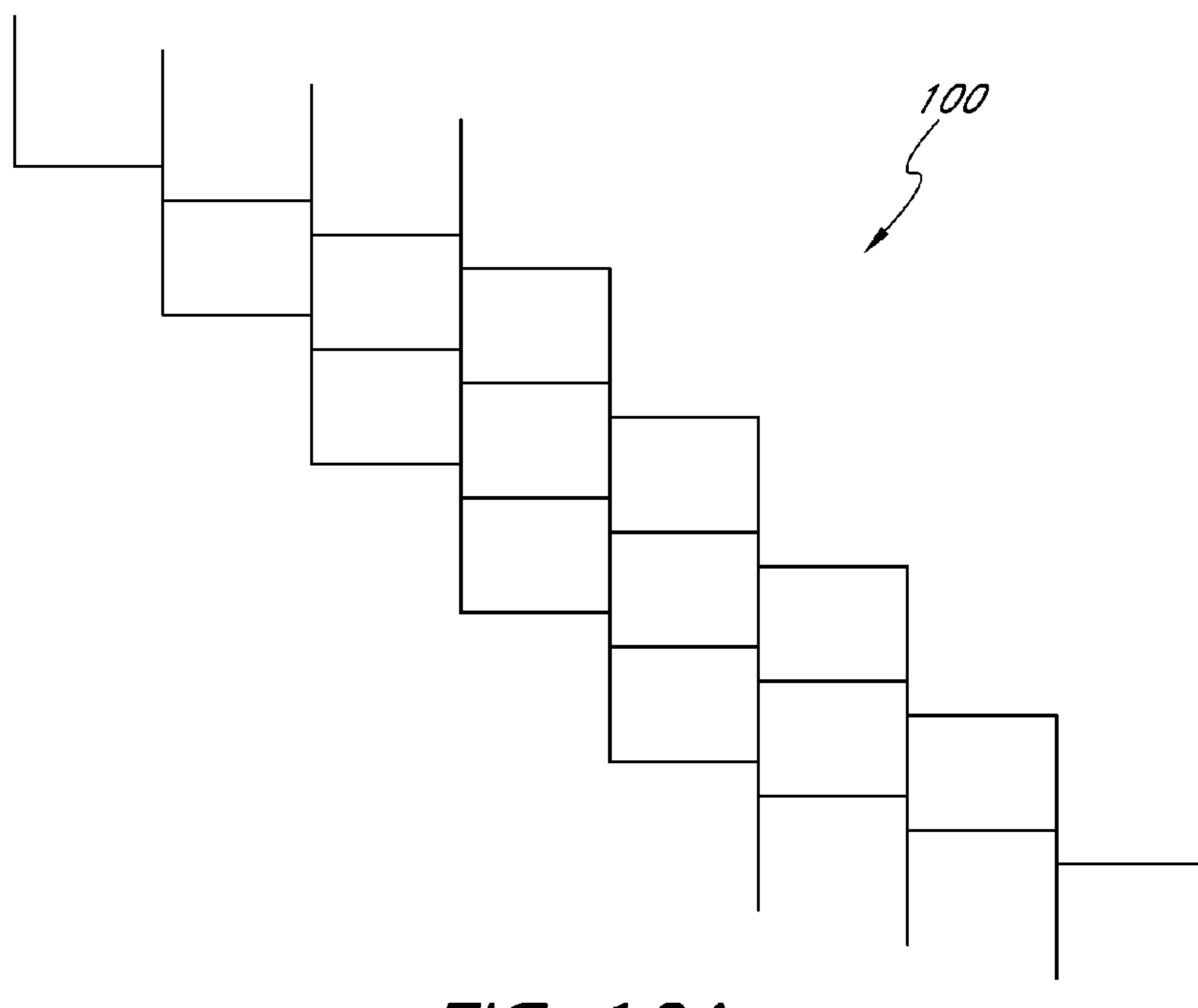

FIG. 10A

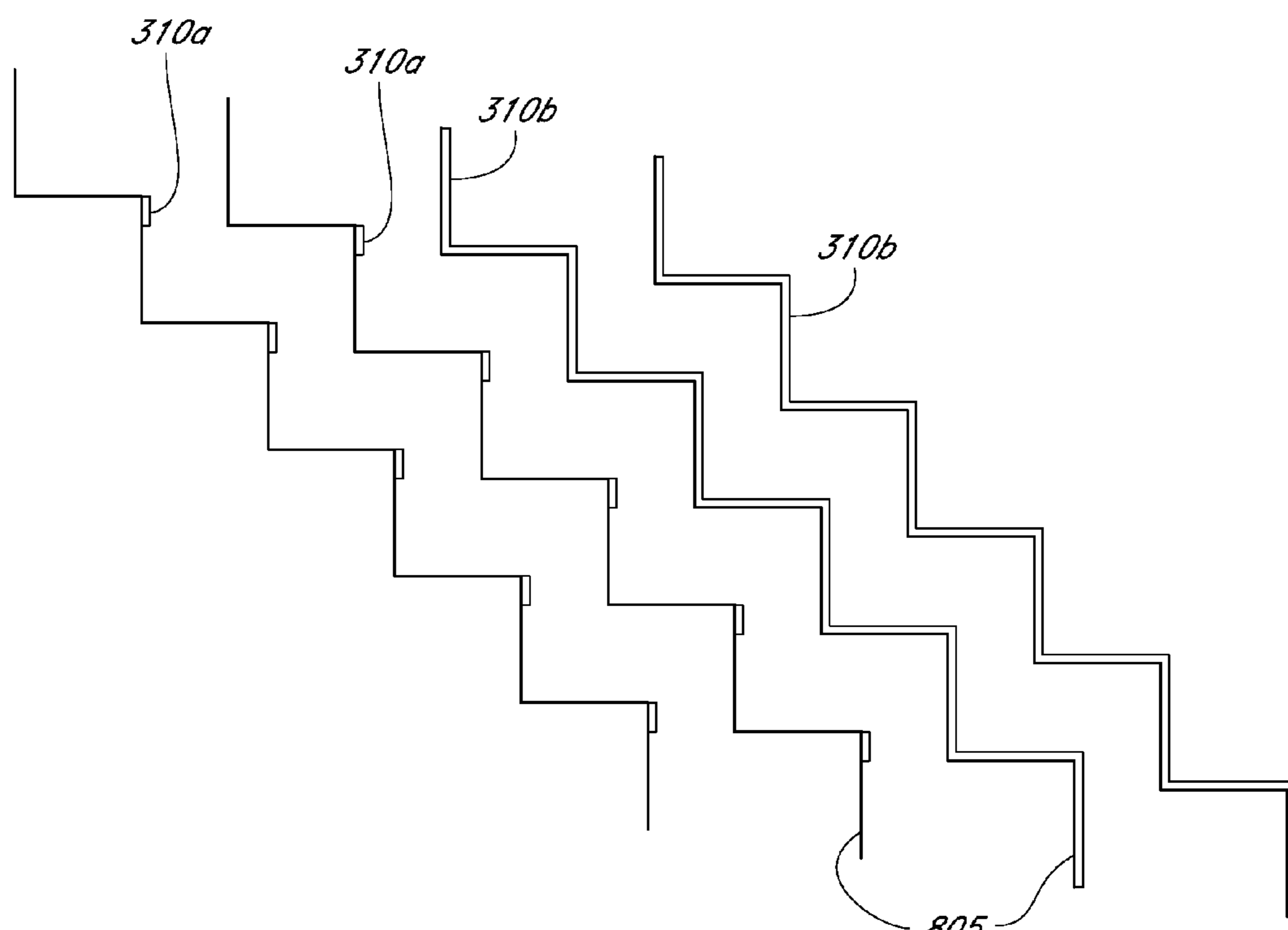

FIG. 10B

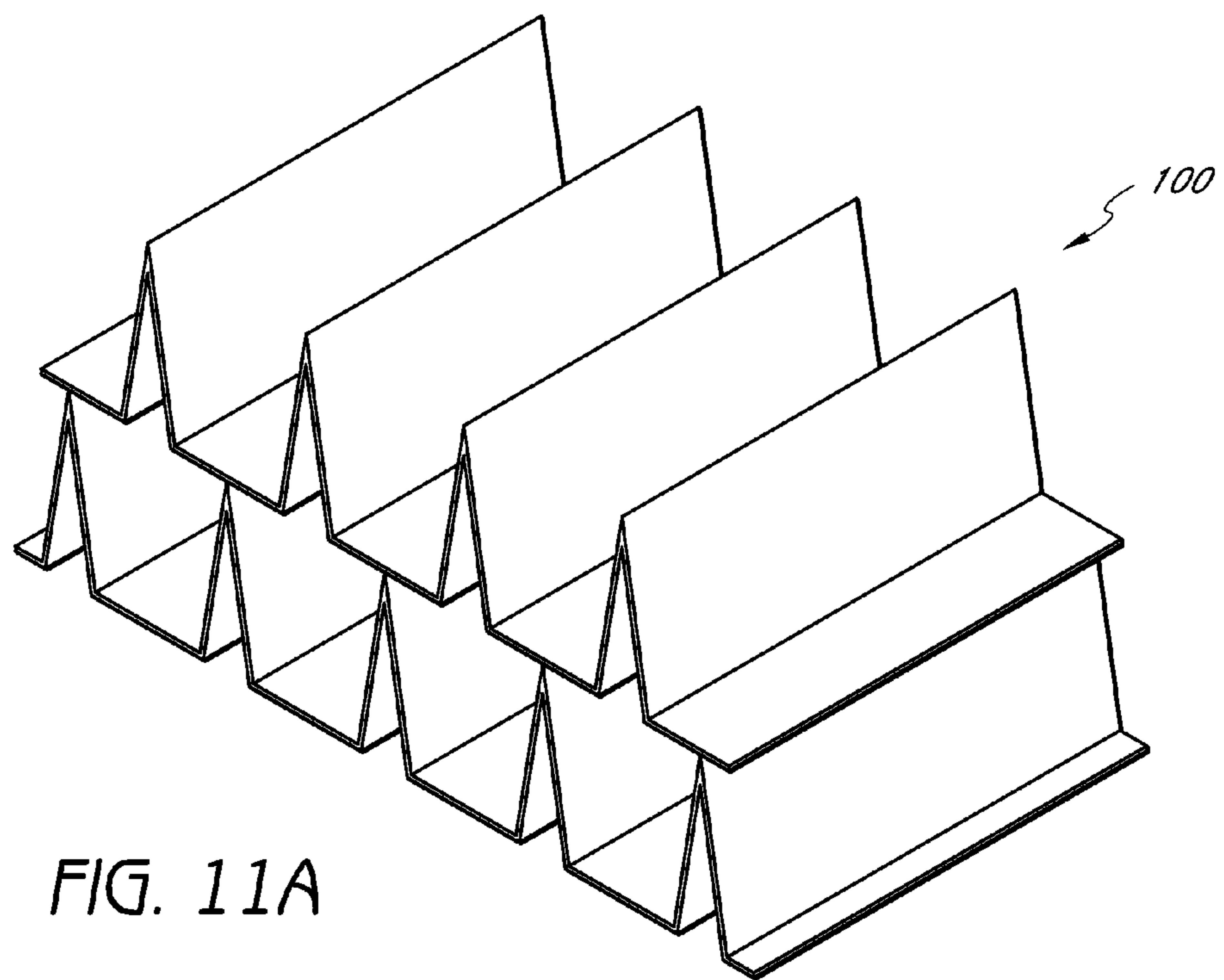

FIG. 11A

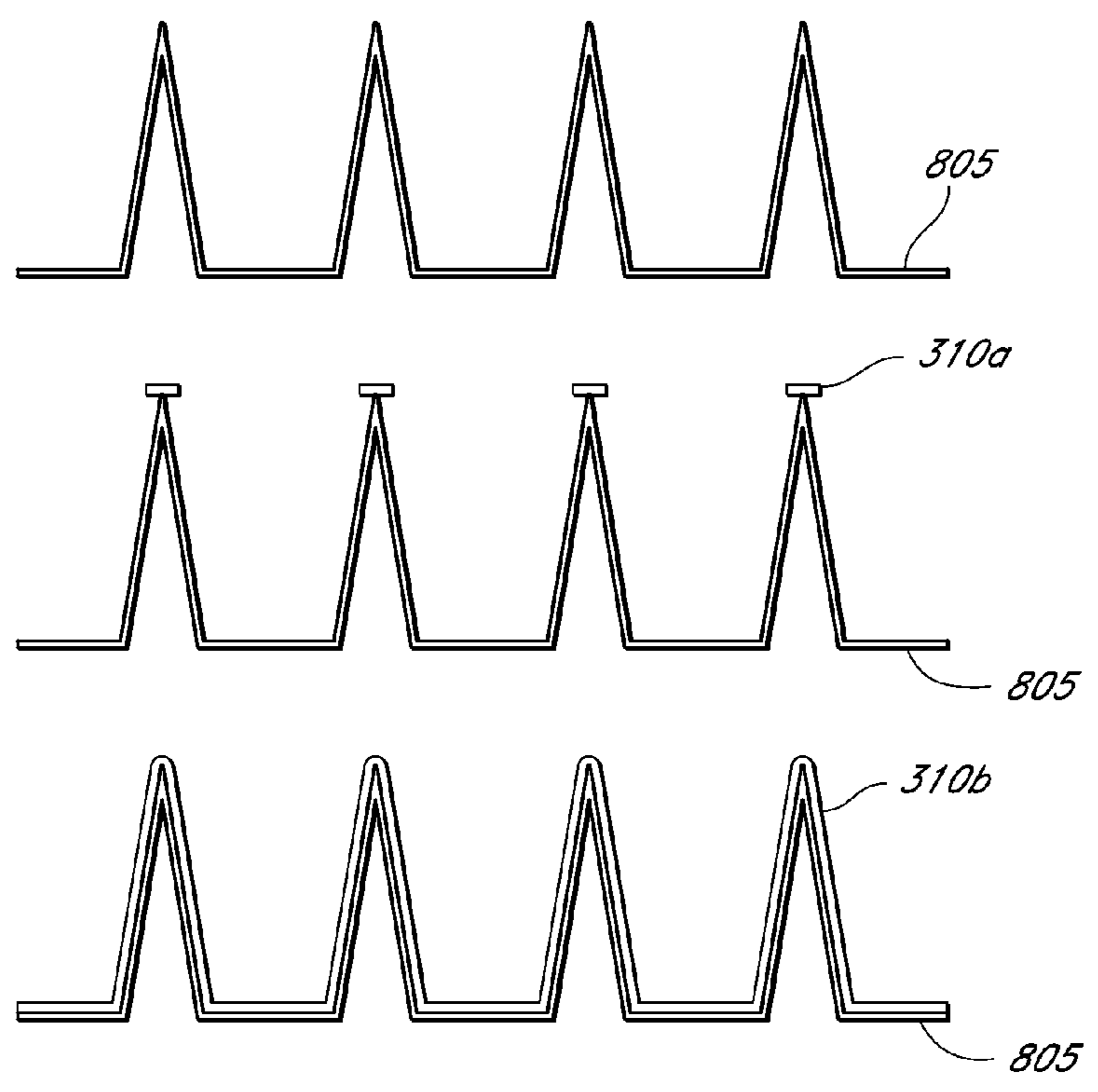

FIG. 11B

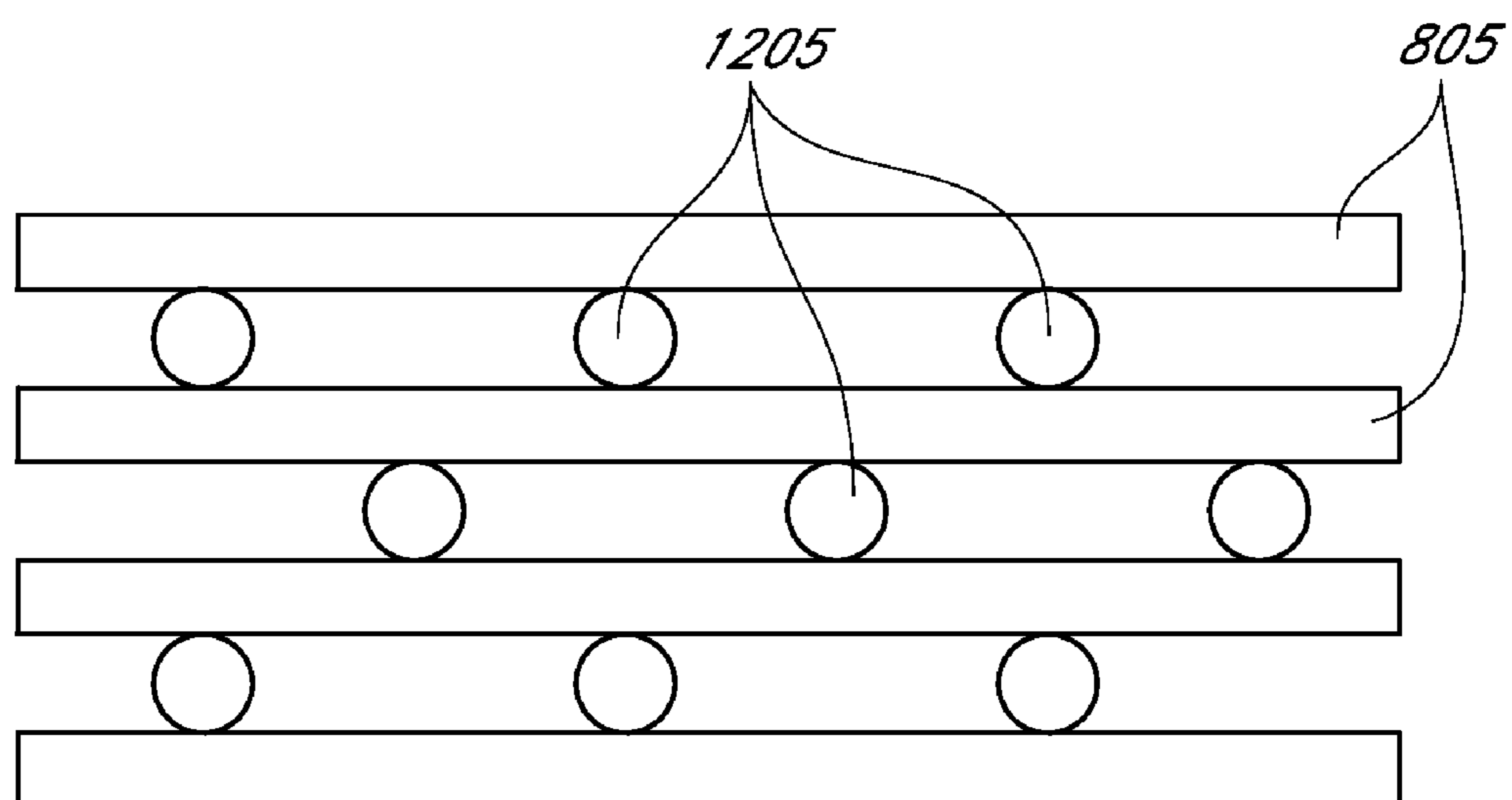

FIG. 12

FIG. 13A

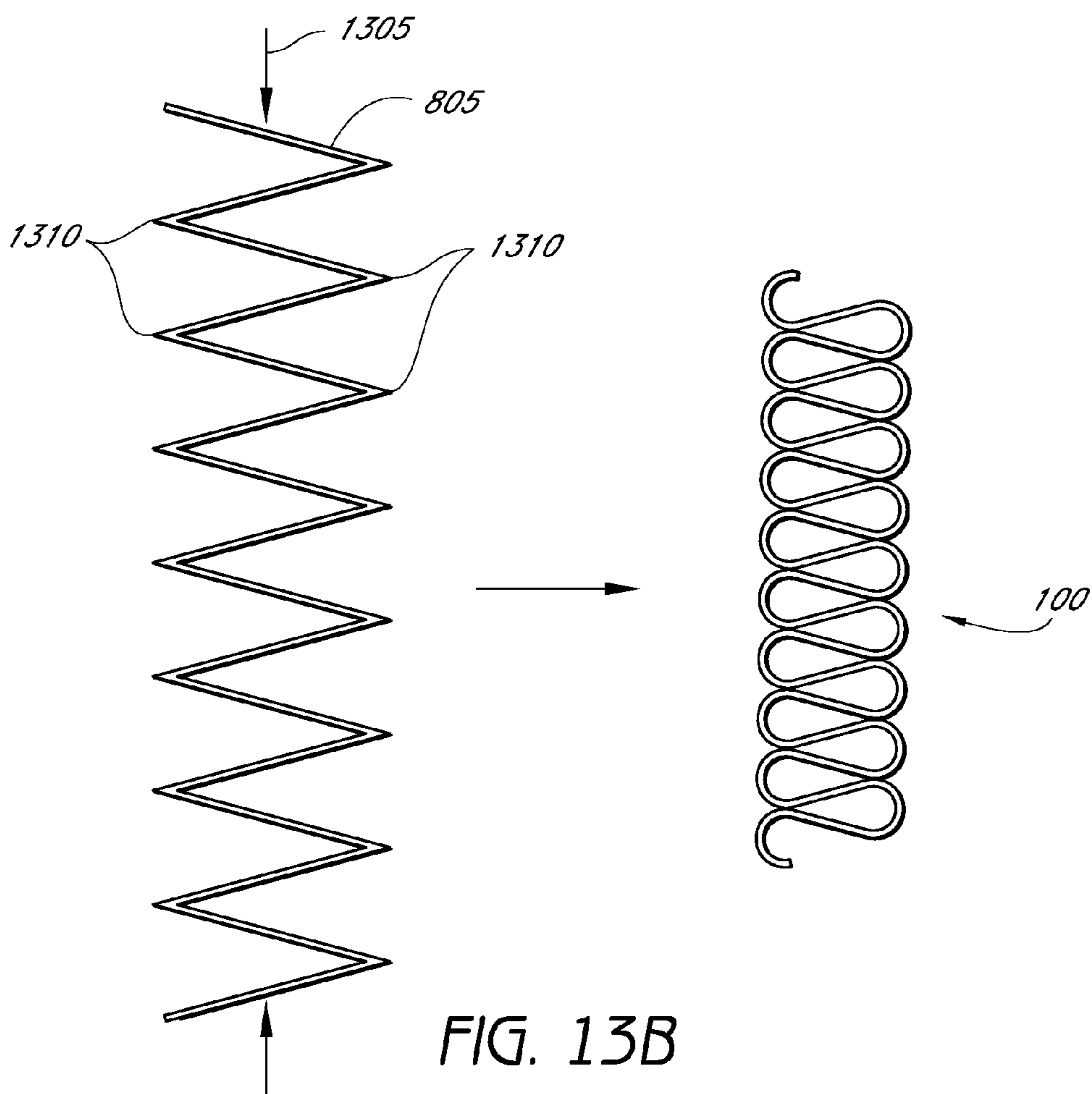
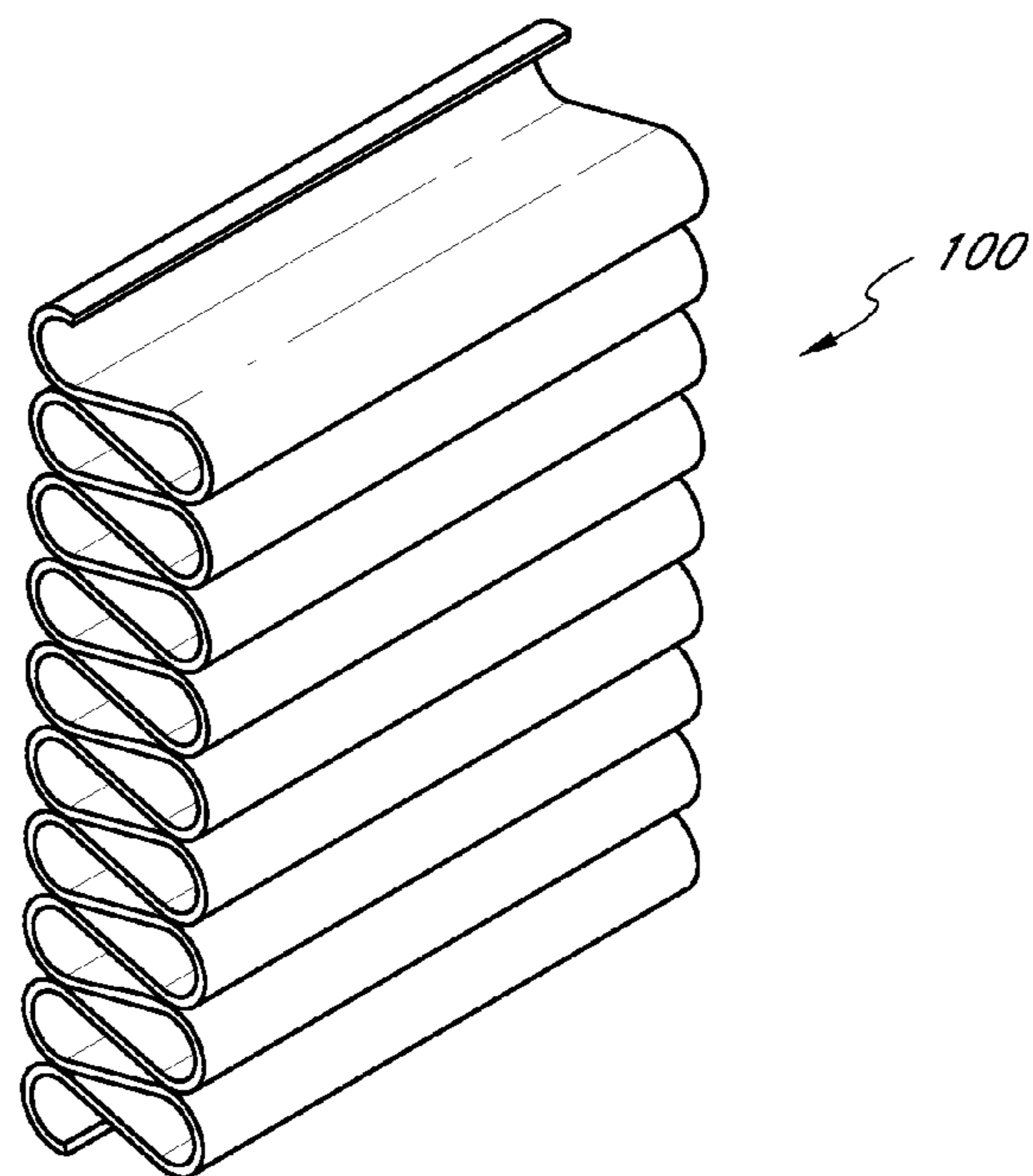

FIG. 13B

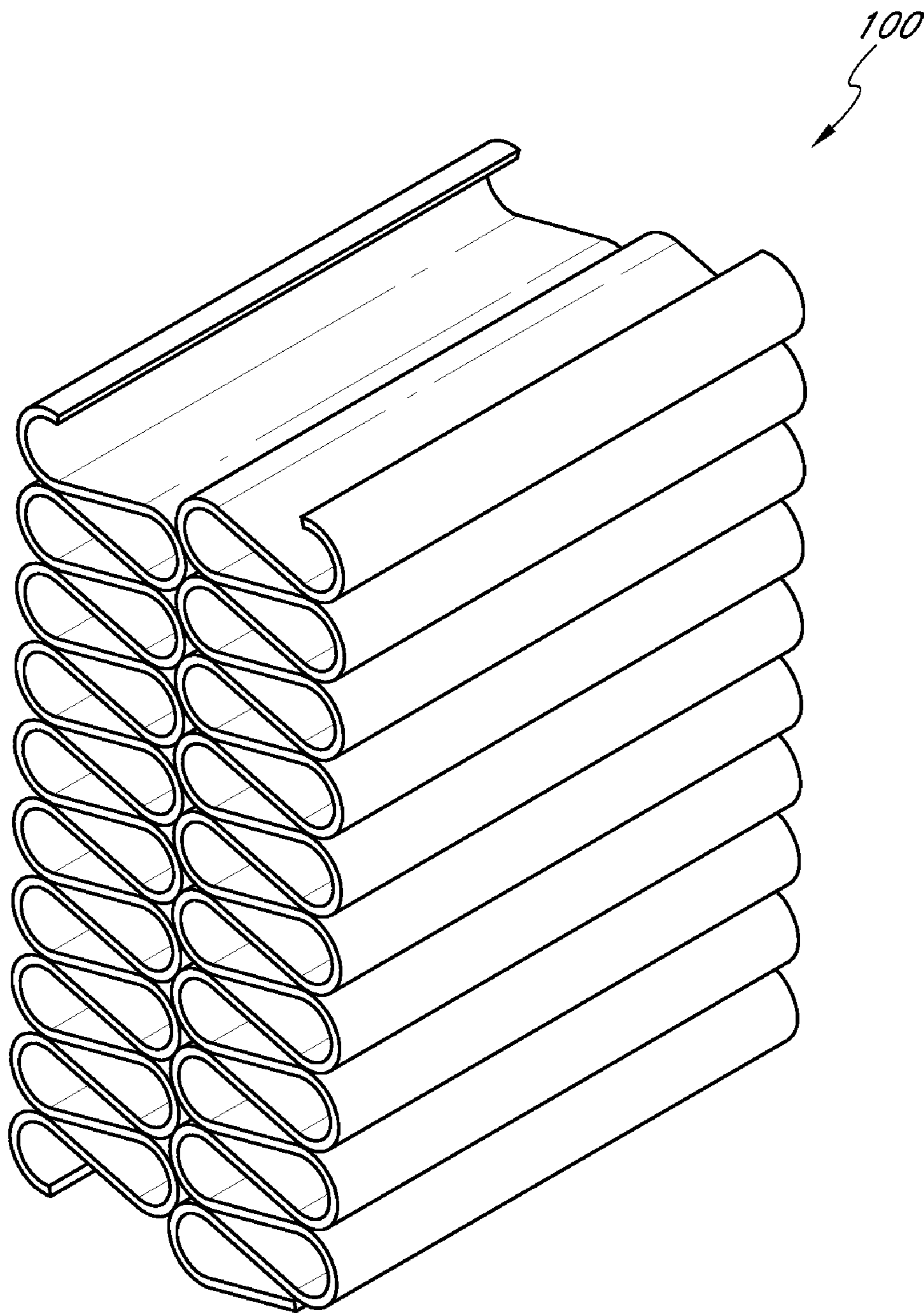

FIG. 13C

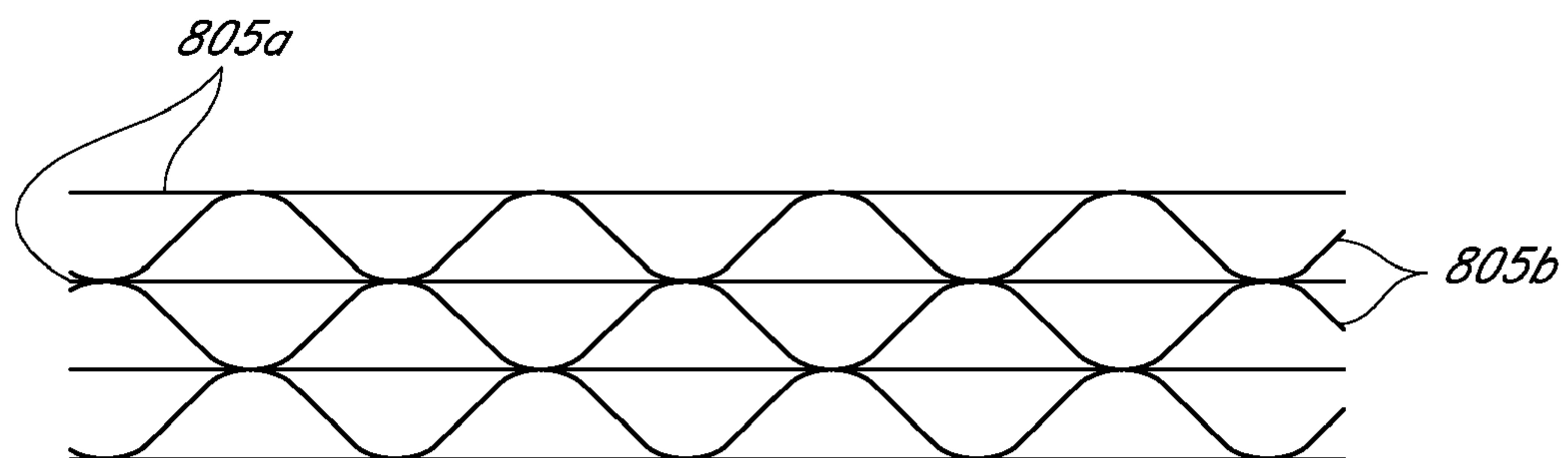

FIG. 14

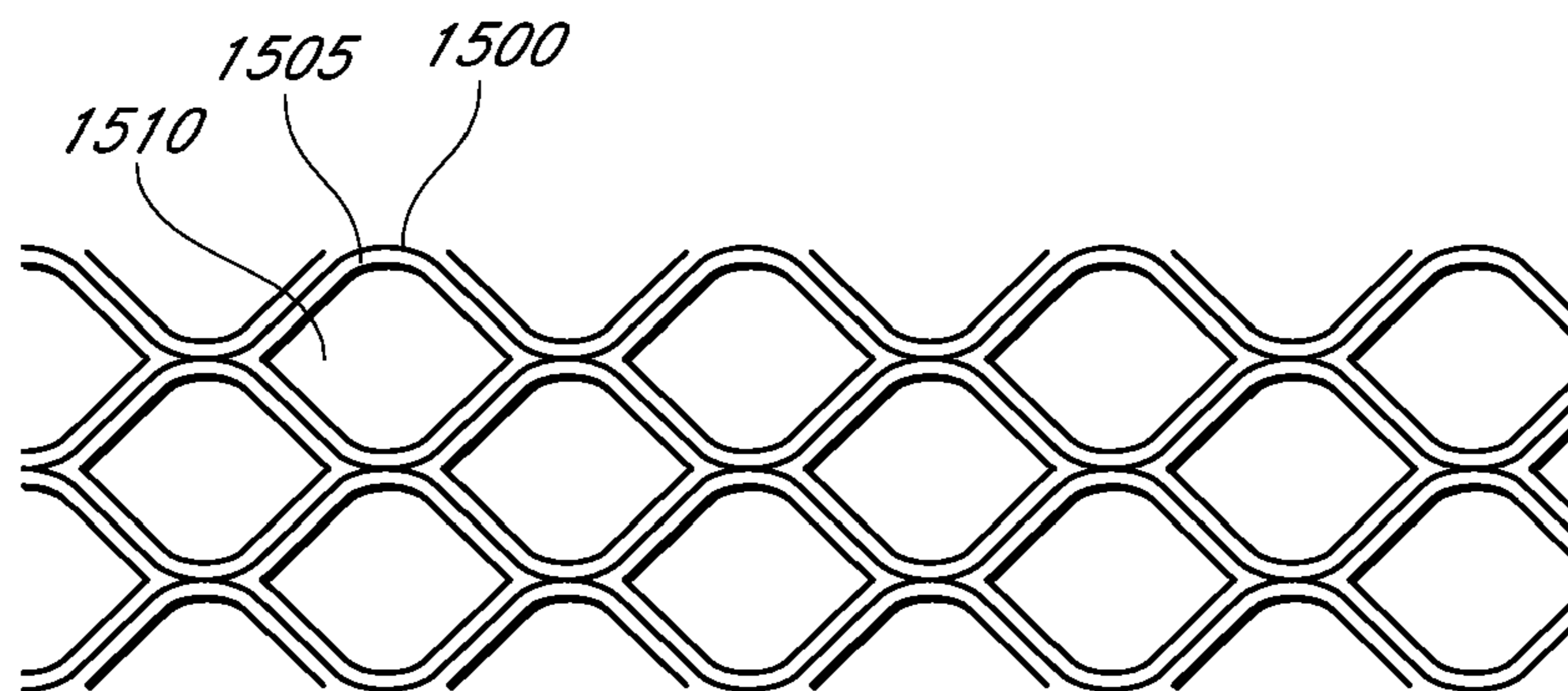

FIG. 15

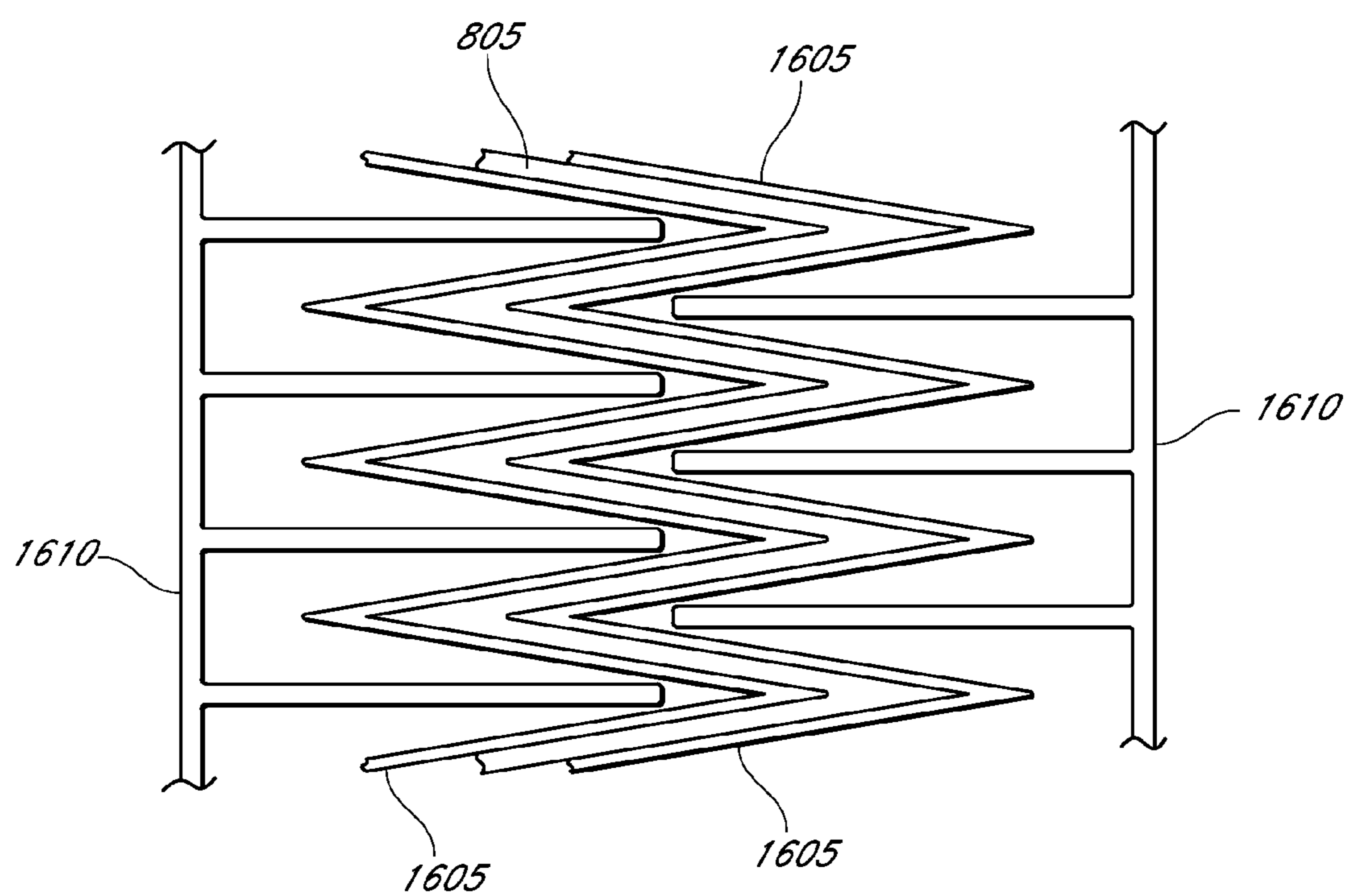

FIG. 16

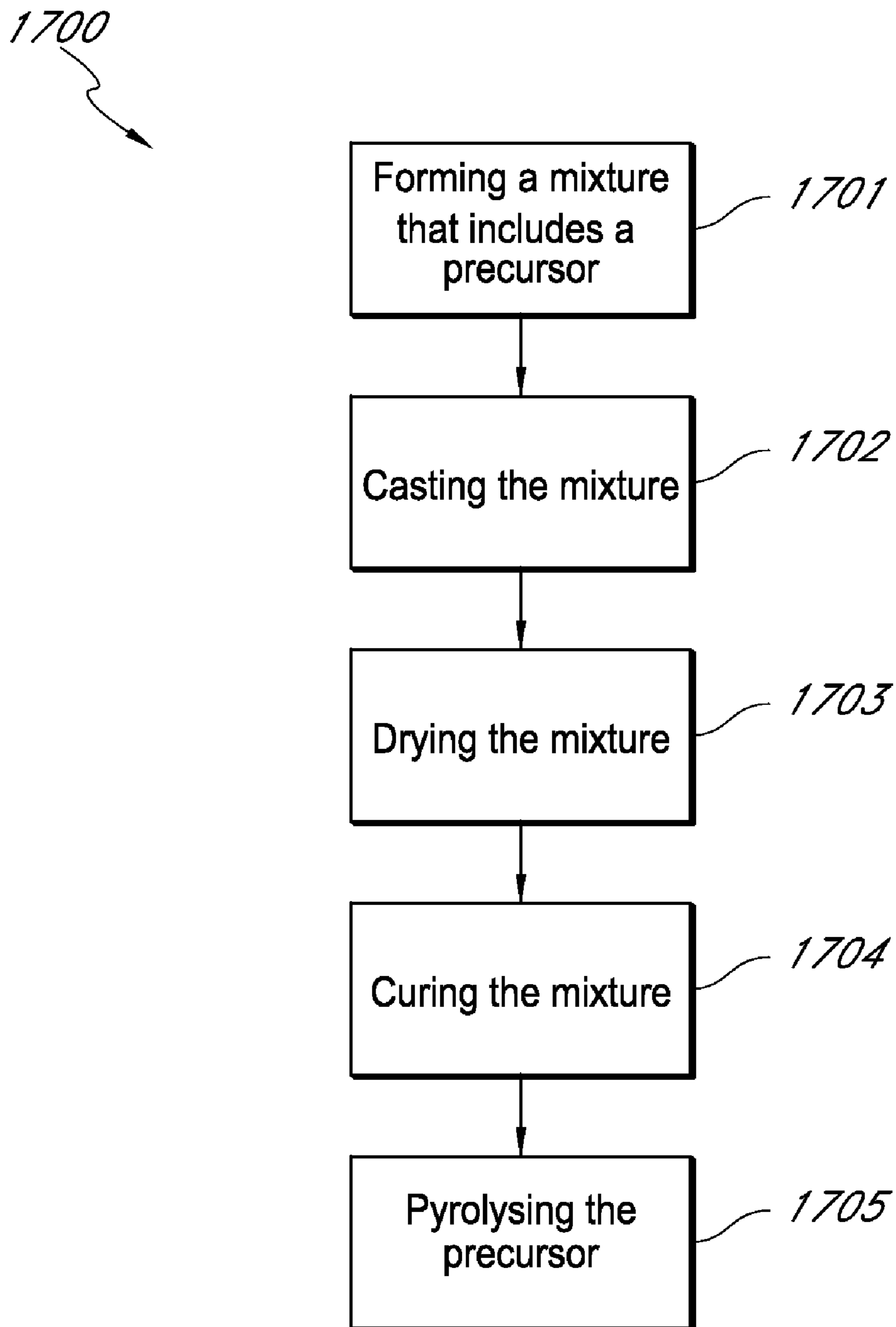

FIG. 17

CARBON ELECTRODE STRUCTURES FOR BATTERIES

CROSS-REFERENCE TO RELATED APPLICATIONS

[0001] This application claims the benefit of U.S. Provisional Application No. 61/226,217, filed Jul. 16, 2009, U.S. Provisional Application No. 61/295,993, filed Jan. 18, 2010, and U.S. Provisional Patent Application No. 61/315,845, filed Mar. 19, 2010, the entirety of each of which is hereby incorporated by reference.

BACKGROUND OF THE INVENTION

[0002] 1. Field of the Invention

[0003] Embodiments of the present disclosure relate to batteries and electrode structures, and in particular, porous electrodes comprising carbon. Further embodiments relate to methods of preparing electrodes for batteries.

[0004] 2. Description of the Related Art

[0005] A lithium ion battery typically includes a separator and/or electrolyte between an anode and a cathode. In one class of batteries, the separator, cathode and anode materials are individually formed into sheets or films. Sheets of the cathode, separator and anode are subsequently stacked or rolled with the separator separating the cathode and anode (e.g., electrodes) to form the battery. For the cathode, separator and anode to be rolled, each sheet must be sufficiently deformable or flexible to be rolled without failures, such as cracks, brakes, mechanical failures, etc. Typical electrodes include electro-chemically active material layers on electrically conductive metals (e.g., aluminum and copper). Films can be rolled or cut into pieces which are then layered into stacks. The stacks are of alternating electro-chemically active materials with the separator between them.

SUMMARY OF THE INVENTION

[0006] In certain embodiments, an electrode includes a body of material formed in substantial part of carbon, the body having an exterior surface and an interior located within the exterior surface, and a plurality of cavities located in the interior of the body. Each of the cavities is in communication with the exterior of the body and has an interior surface. The cavities can each be sized to accommodate a battery separator located therein and substantially covering the interior surface of the cavity while still permitting sufficient room for a second electrode material to be located within the cavity spaced from the interior surface of the cavity by the separator. The cavities may be substantially regularly spaced. The cavities can be at least 50 percent of the volume of the body.

[0007] In certain embodiments, an electrode for a battery includes a structure having a plurality of engineered cavities and having a composition comprising carbon that is electrochemically active. The electrode may be an anode for a battery. The structure can be configured to be an electrochemically active component and a current collector. The structure may be a monolithic structure and/or be self-supported. The structure may consist essentially of electrochemically active material. The carbon may be formed from a precursor and be electrically conductive. The carbon may also be substantially homogeneous throughout the structure and/or be a substantially continuous phase in the structure. The structure may not include an inactive binder. The composition can include sili-

con. The plurality of engineered cavities can have an average pore dimension of at least 100 nm or at least 1 μm .

[0008] In certain embodiments, a battery is provided. The battery can include a first electrode comprising electrochemically active carbon and having a plurality of pores, a separator located within the plurality of pores, and a second electrode located within the plurality of pores, wherein the separator electrically isolates the first electrode from the second electrode. The battery may be a lithium ion battery and/or the second electrode may be a lithiated intercalation compound. The first electrode may be an electrode as described herein.

[0009] In certain embodiments, an electrode formed of a composition comprising carbon is provided. The electrode includes a first body of the composition, at least a portion of the first body having a first surface, a second surface and an interior between the first surface and the second surface, and a second body of the composition, at least a portion of the second body having a first surface, a second surface and an interior between the first surface and the second surface. The first and second bodies are coupled to form a portion of the electrode such that the first surfaces of the first and second bodies form a plurality of cavities between the first surfaces. An average pore size of the interior between the two surfaces can be at least an order of magnitude smaller than an average engineered cavity size outside of the interior.

[0010] In certain embodiments, a method of forming a battery electrode includes providing a plurality of members, applying an attachment substance to a first portion of at least some of the plurality of members, contacting a second portion of at least some of the plurality of members with the attachment substance, and pyrolysing the attachment substance to form a porous structure comprising electrochemically activated carbon. The method can also include stacking layers of the plurality of members with a space between each neighboring member, applying the attachment substance on at least one edge of the members, contacting a base with the attachment substance on at least one edge of the members, and pyrolysing the attachment substance.

[0011] The method, in one embodiment, includes stacking a first member, a second member, a third member and a fourth member of the plurality of members, at least one edge of the first member and at least one edge of the third member extend beyond at least one edge of the second member and at least one edge of the fourth member, at least one edge of the second member and at least one edge of the fourth member extend beyond at least one edge of the first member and at least one edge of the third member. The method can include applying the attachment substance on the at least one edge of the first member and the at least one edge of the third member that extend beyond the at least one edge of the second member and the at least one edge of the fourth member, and applying the attachment substance on the at least one edge of the second member and the at least one edge of the fourth member that extend beyond the at least one edge of the first member and the at least one edge of the third member. Furthermore, the method may include contacting a first base with the attachment substance on the at least one edge of the first member and the at least one edge of the third member that extend beyond the at least one edge of the second member and the at least one edge of the fourth member, and contacting a second base with the attachment substance on the at least one edge of the second member and the at least one edge of the fourth member that extend beyond the at least one edge of the first member and the at least one edge of the third member. In some

embodiments, the method includes stacking an insert layer between the first member and the second member to create a spacing between the first member and the second member, and removing the insert layer after pyrolysing the attachment substance.

[0012] In another embodiment, the method further includes providing a first member of the plurality of members, applying more than one line of the attachment substance on at least one side of the first member, stacking a second member on the more than one line of the attachment substance on at least one side of the first member, applying more than one line of the attachment substance on the second member, stacking a third member on the more than one line of the attachment substance on the second member, wherein the first member, the second member and the third member comprise a precursor that can be converted to electro-chemically active carbon, separating the first member, the second member and the third member in areas between the attachment substance, and pyrolysing the first member, the second member and the third member. Each of the lines of the attachment substance can be about midway between the lines of neighboring layers. A thickness of the lines can be about one-third a distance between adjacent lines or about the same as a distance from lines of neighboring layers.

[0013] The method may further include applying the attachment substance to at least one side of at least one of a plurality of members, at least one of the members comprises contours, and stacking the plurality of members. The contours may include folds, creases or pleats in the sheets.

[0014] In certain embodiments, the method includes providing a spacer, stacking the spacer between two members to physically separate the two members, and attaching the spacer to the two members with an attachment substance.

[0015] In other embodiments, the method includes providing a first member of the plurality of members, the first member is pleated and comprises a precursor, applying an attachment substance comprising a precursor to both sides of the first member, compressing the first member so that at least a portion of the first member contacts at least another portion of the first member, and pyrolysing the first member. The method may also include providing a second member of the plurality of members, the second member is pleated and comprises a precursor, compressing the second member so that at least a portion of the second member contacts at least another portion of the second member, and attaching the second member to the first member.

[0016] In certain embodiments, a method of forming a battery electrode includes molding or extruding a precursor into a structure that comprises a plurality of elongated pores, and pyrolysing the structure to form at least some electrochemically activated carbon.

[0017] Any of the methods may include applying a separator at least partially on at least one of the plurality of members. The attachment substance can include a precursor. The precursor can be, for example, a polyimide precursor. The attachment substance can include silicon. The plurality of members can include a precursor.

BRIEF DESCRIPTION OF THE DRAWINGS

[0018] FIG. 1 illustrates an embodiment of a carbon electrode.

[0019] FIG. 2 illustrates an embodiment of the carbon electrode of FIG. 1 with a separator and a second electrode.

[0020] FIGS. 3A-D illustrate an embodiment of a method of making the carbon electrode of FIG. 1.

[0021] FIGS. 4A-D illustrate another embodiment of a method of making the carbon electrode of FIG. 1.

[0022] FIG. 5 illustrates an embodiment of an electrically conductive porous foil on the carbon electrode.

[0023] FIGS. 6A-B illustrate an embodiment of a method of making the electrically conductive porous foil of FIG. 5.

[0024] FIG. 7 illustrates an embodiment of two carbon electrode of FIG. 1 stacked to form a battery.

[0025] FIGS. 8A-C illustrate an embodiment of a carbon electrode accordion structure and a method of making the carbon electrode accordion structure.

[0026] FIGS. 9A-B illustrate an embodiment of a carbon electrode honeycomb structure and a method of making the carbon electrode honeycomb structure.

[0027] FIGS. 10A-B illustrate an embodiment of a carbon electrode square or rectangular structure and a method of making the carbon electrode square or rectangular structure.

[0028] FIGS. 11A-B illustrate an embodiment of a carbon electrode folded-sheet structure and a method of making the carbon electrode folded-sheet structure.

[0029] FIG. 12 illustrates an embodiment of a carbon electrode structure with spacers between sheets.

[0030] FIGS. 13A-C illustrate an embodiment of a carbon electrode ribbon candy structure and a method of making the carbon electrode ribbon candy structure.

[0031] FIG. 14 illustrates an embodiment of a carbon electrode structure formed from alternating layers of contoured sheets and flat sheets.

[0032] FIG. 15 illustrates an embodiment of a battery with a carbon electrode structure with porosity with a separator deposited within the porosity of the carbon electrode structure and a second electrode electrically separated from the electrode by the separator.

[0033] FIG. 16 illustrates an embodiment of a battery with a pleated carbon electrode structure with a separator deposited on the pleated carbon electrode structure along with a second electrode between the pleats of the carbon electrode structure.

[0034] FIG. 17 illustrates an embodiment of a method of forming a material comprising carbon that includes forming a mixture that includes a precursor, casting the mixture, drying the mixture, curing the mixture, and pyrolysing the precursor.

DETAILED DESCRIPTION

[0035] To be able to utilize electrode materials that may not be able to be rolled, other structures and methods are described herein. In particular, carbon can advantageously be used both as an electro-chemically active electrode material and as an electrically conductive material. The active materials in a battery are those that participate in the electrochemical charge/discharge reaction. Generally, carbon in a solid form (e.g., not carbon powder with a binder) has insufficient deformability to be able to be rolled as in a conventional wound battery; therefore, other carbon structures described herein can be used as carbon electrodes. Carbon structures and carbon electrodes include structures and electrodes that comprise carbon. Furthermore, carbon structures and carbon electrodes may or may not include one or more additional components such as silicon.

[0036] Typical carbon anode electrodes include a current collector such as a copper sheet which is an inactive material. Carbon is deposited onto the collector along with an inactive

binder material. Carbon is often used because it has excellent electrochemical properties and is also electrically conductive. If the current collector layer (e.g., copper layer) was removed, the carbon along with the polymer binder material would be unable to mechanically support itself. Therefore, conventional electrodes require a support structure such as the collector to be able to function as an electrode.

[0037] The electrodes and electrode compositions described in this application can be or be used to produce electrodes that are self-supported. The need for a metal foil current collector is eliminated or minimized because conductive carbonized precursor or polymer is used for current collection in the electrode structure. The carbonized polymer can form a substantially continuous conductive carbon phase in the entire electrode as opposed to particulate carbon suspended in a non-conductive binder in a conventional lithium-ion battery electrode (e.g., the electrode does not include a binder such as an organic binder). Advantages of a carbon composite blend that utilizes a carbonized polymer include, but are not limited to, 1) higher capacity, 2) enhanced overcharge/discharge protection, 3) lower irreversible capacity due to the elimination (or minimization) of metal foil current collectors, and 4) potential cost savings due to simpler manufacturing.

[0038] This application also describes new methods of creating monolithic, self-supported electrodes using a carbonized polymer. Because the polymer is converted into a conductive matrix, the resulting electrode is conductive enough that a metal foil or mesh current collector can be omitted or minimized. In certain embodiments, the resulting electrode is an electrode that is comprised substantially of active material. In further embodiments, the resulting electrode consists essentially of or consists of active material. In some embodiments, the electrode consists essentially of or consists of active material and conductive material such as metal.

[0039] The electrode structures described herein can be used as an anode in most conventional lithium ion batteries; they can also be used as the cathode in some electrochemical couples with additional additives. The electrode structures can also be used in either secondary batteries (e.g., rechargeable) or primary batteries (e.g., non-rechargeable). In certain embodiments, the electrode structures are self-supported structures. In further embodiments, the electrode structures are self-supported monolithic structures. For example, the electrode may not include a collector (e.g., metal foil).

[0040] Described herein are also three-dimensional electrode structures and methods of making that have increased surface area per unit volume compared to a sheet. The three-dimensional electrode structures can have porous or cellular structure which can include, for example, pores, pits, grooves, cavities, and/or holes. In certain embodiments, the electrode structure is an open-cellular electrode structure. Advantageously, these electrode structures comprise electrochemically activated carbon that can act as both an active material and also as a current collector. These electrode structures can also be self-supporting electrode structures. In particular, the self-supporting electrode structure can include a self-supported composition that comprises electrochemically activated carbon. Self-supporting allows the structure or composition to retain a desired shape with out additional support members such as a metal foil current collector. In certain embodiments, the self-supported structure is a monolithic structure.

[0041] The self-supported composition and/or electrode can be substantially homogenous. For example, the electrochemically activated carbon can be substantially homogeneous throughout the self-supported composition and/or electrode. The composition and/or electrode can include a matrix of activated carbon and/or a continuous phase of activated carbon. In certain embodiments, the composition and/or electrode do not include an inactive binder (e.g., organic binder).

[0042] The electrodes described herein can be used in a battery such as a lithium-ion battery. In certain embodiments, a battery includes a first electrode comprising electrochemically active carbon and a porous or cellular structure. A separator film can be deposited (e.g., coated) within the porous or cellular structure, and a second electrode can then be positioned within the porous or cellular structure so that the separator electrically isolates the first electrode from the second electrode. Furthermore, an electrolyte may or may not be used in the battery; for example, a nonaqueous electrolyte may be used. Described below are further examples of electrodes and batteries along with methods of making the electrodes and batteries.

[0043] As described above, the carbon structures can be used as an anode and/or cathode in a battery. In certain embodiments, the carbon structure is chemically treated to be used as a cathode. For example, the carbon structure can go through a fluorination process or is treated with fluorine. In certain embodiments, the carbon structure does not necessarily need a chemical treatment to be used as an anode. In batteries described herein, the batteries have a carbon electrode and a second electrode. The second electrode can be any type of electrode that is compatible with the carbon electrode. For example, if the carbon electrode is the anode, the second electrode can be a suitable cathode electrode. Alternatively, if the carbon electrode is the cathode, the second electrode can be a suitable anode electrode. In certain embodiments, the second electrode is a second carbon electrode. In further embodiments, the second electrode comprises a lithiated intercalation compound.

[0044] The carbon structures can have a variety of compositions. For example, the carbon structure can be formed by first forming a structure of precursor (e.g., polymer precursor) and then pyrolysing the precursor to form the carbon structure. Precursor compositions, electrode compositions, and separator compositions are further described in U.S. patent application Ser. No. 12/728,157, U.S. Provisional Patent Application No. 61/161,740, U.S. Provisional Patent Application No. 61/295,993, and U.S. Provisional Patent Application No. 61/315,845, the entirety of each of which is hereby incorporated by reference.

[0045] FIG. 17 illustrates one embodiment of a method **1700** of forming a composition comprising carbon such as a carbon material. In certain embodiments, the method of forming a carbon material includes forming a mixture including a precursor, block **1701**. The method can further include pyrolysing the precursor to convert the precursor to a carbon phase. The precursor mixture can include carbon additives such as graphite active material, chopped or milled carbon fiber, carbon nanofibers, carbon nanotubes, and/or other carbons. After the precursor is pyrolysed, the resulting carbon material can be a self-supporting monolithic structure. In certain embodiments, one or more materials are added to the mixture to form a carbon composite material. For example, silicon particles can be added to the mixture. The carbonized precursor

sor results in an electrochemically active structure that holds the carbon composite material together. For example, the silicon particles can be distributed throughout the carbon composite material. Advantageously, the carbonized precursor will be a structural material as well as an electro-chemically active and electrically conductive material. In certain embodiments, material particles added to the mixture are homogeneously distributed throughout the carbon composite material to form a homogeneous composite.

[0046] The mixture can include a variety of different components. The mixture can include one or more precursors. In certain embodiments, the precursor is a polyimide. For example, the precursor can be polyamic acid. Other precursors include phenolic resins, epoxy resins, and other polymers. The mixture can further include a solvent. For example, the solvent can be N-methyl-pyrrolidone (NMP). Other possible solvents include acetone, diethyl ether, gamma butyrolactone, isopropanol, dimethyl carbonate, ethyl carbonate, dimethoxyethane, etc. Examples of precursor and solvent solutions include PI-2611 (HD Microsystems), PI-5878G (HD Microsystems) and VTEC PI-1388 (RBI, Inc.). PI-2611 is comprised of >60% n-methyl-2-pyrrolidone and 10-30% s-biphenyldianhydride/p-phenylenediamine. PI-5878G is comprised of >60% n-methylpyrrolidone, 10-30% polyamic acid of pyromellitic dianhydride/oxydianiline, 10-30% aromatic hydrocarbon (petroleum distillate) including 5-10% 1,2,4-trimethylbenzene. Other examples of precursor polymers include phenolic resins that may be dissolved in solvents including n-methyl-2-pyrrolidone or isopropyl alcohol. In certain embodiments, the amount of precursor in the solvent is about 10 to 30 wt. %. Additional materials can also be included in the mixture. For example, as previously discussed, silicon particles or carbon particles including graphite active material, chopped or milled carbon fiber, carbon nanofibers, carbon nanotubes, and other conductive carbons can be added to the mixture. In addition, the mixture can be mixed to homogenize the mixture.

[0047] In certain embodiments, the mixture is cast on a substrate, block 1702 in FIG. 17. In some embodiments, casting includes using a gap extrusion or a blade casting technique. The blade casting technique can include applying a coating to the substrate by using a flat surface (e.g., blade) which is controlled to be a certain distance above the substrate. A liquid or slurry can be applied to the substrate, and the blade can be passed over the liquid to spread the liquid over the substrate. The thickness of the coating can be controlled by the gap between the blade and the substrate since the liquid passes through the gap. As the liquid passes through the gap, excess liquid can also be scraped off. For example, the mixture can be cast on a polymer sheet, a polymer roll, or foils or rolls made of glass or metal.

[0048] The mixture can then be dried to remove the solvent, block 1703, to form a precursor member, sheet, film, etc. For example, a polyamic acid and NMP solution can be dried at about 110° C. for about 2 hours to remove the NMP solution. The dried mixture can then be removed from the substrate. For example, an aluminum substrate can be etched away with HCl. Alternatively, the dried mixture can be removed from the substrate by peeling or otherwise mechanically removing the dried mixture from the substrate. In certain embodiments, the dried mixture is a film or sheet.

[0049] In some embodiments, the dried mixture or precursor member is cured, block 104. A hot press can be used to cure and to keep the dried mixture flat. For example, the dried

mixture from a polyamic acid and NMP solution can be hot pressed at about 200° C. for about 8 to 16 hours. Alternatively, the entire process including casting and drying can be done as a roll-to-roll process using standard film-handling equipment. The dried mixture can be rinsed to remove any solvents or etchants that may remain. For example, de-ionized (DI) water can be used to rinse the dried mixture. In certain embodiments, the dried mixture is cut or mechanically sectioned into smaller pieces.

[0050] The mixture or precursor member can further go through pyrolysis to convert the precursor to carbon, block 1705. In certain embodiments, the mixture is pyrolysed in a reducing atmosphere. For example, an inert atmosphere, a vacuum and/or flowing argon, nitrogen, or helium gas can be used. In certain embodiments, the mixture is heated to about 900 to 1350° C. For example, polyimide formed from polyamic acid can be carbonized at about 1175° C. for about one hour. In certain embodiments, the heat up rate and/or cool down rate of the mixture is about 10° C./min. In certain embodiments, a holder can be used to keep the mixture in a particular geometry. The holder can be graphite, metal, etc. In certain embodiments, the mixture is held flat. After the mixture is pyrolysed, tabs can be attached to the pyrolysed material to form electrical contacts. For example, nickel, copper or alloys thereof can be used for the tabs.

[0051] In certain embodiments, one or more of the methods described herein is a continuous process. For example, casting, drying, curing and pyrolysis can be performed in a continuous process (e.g., the mixture can be coated onto a glass or metal cylinder). The mixture can be dried while rotating on the cylinder creating a film. The film can be transferred as a roll or peeled and fed into another machine for further processing. Extrusion and other film manufacturing techniques known in industry could also be utilized prior to the pyrolysis step.

[0052] Pyrolysis of the precursor results in a carbon material. In certain embodiments, the carbon material is a hard carbon. When the mixture includes one or more additional materials, a carbon composite material can be created. In particular, the mixture can include silicon particles creating a silicon-carbon or silicon-carbon-carbon composite material.

[0053] A battery with the carbon structures described herein can be any size. For example, the size can include the width, length and height of the battery. Embodiments of batteries include sizes on the order of 10^{-6} meters, 10^{-5} meters, 10^{-4} meters, 10^{-3} meters, 10^{-2} meters, 10^{-1} meters, 10^0 meters, and 10^1 meters. Other sizes are also possible.

[0054] In certain embodiments, an electrode includes a body (e.g., structure) of material formed in substantial part of carbon, the body having an exterior surface and an interior located within the exterior surface, and a plurality of cavities located in the interior of the body. Each of the cavities can be in communication with the exterior of the body and having an interior surface. The cavities can each be sized to accommodate a battery separator located therein and substantially covering the interior surface of the cavity while still permitting sufficient room for a second electrode material to be located within the cavity spaced from the interior surface of the cavity by the separator.

[0055] The porous or cellular structure (e.g., porosity) can also have various dimensions. The porosity can be engineered wherein the pores or cavities are selectively designed. For example, the pores can have a regular or ordered pattern or arrangement, and/or the pores can be regu-

larly or evenly spaced from one another. The porous structure can include open porosity or be substantially open porosity (e.g., pores are open to an external surface of the porous structure). The pores (e.g., openings, pits, grooves, cavities, and/or holes) can have a sufficient size in order to include a separator and/or second electrode within the porosity (e.g., the pores have dimensions or are sized so that a separator can be inserted or deposited into the pores).

[0056] For example, the pore or cavity dimensions (e.g., width, length, depth, diameter) of the pores can be greater than about 100 nm and/or less than about 5 mm. The pores can include a largest dimension and a smallest dimension such as elongated pores. In certain embodiments, the average smallest dimension is between about 1 μm and about 100 μm . In a further embodiments, the average smallest dimension is between about 100 μm and about 1 mm or is between about 100 nm and 1 μm . The average largest dimension can be, for example, between about 100 μm and about 1 mm, or between about 1 mm and about 5 mm. In certain embodiments, the largest dimension is the pore length and the smallest dimension is a cross-sectional dimension. In further embodiments, the average smallest cross-sectional area of the pores is between about 1 μm^2 and about 0.01 mm^2 and/or between about 0.01 mm^2 and about 1 mm^2 . The average volume of the pores can be, for example, 1 μm^3 to 0.001 mm^3 and/or between about 0.001 mm^3 and about 1 mm^3 . An average engineered pore size (e.g., width, length, depth, diameter, cross-sectional area, volume) can be at least an order of magnitude larger than material porosity (e.g., porosity that may be formed when the structure is pyrolysed or converted into carbon) that is between neighboring engineered pores. For example, the material porosity may substantially be closed porosity (e.g., pores that are not open to an external surface of porous structure).

[0057] In certain embodiments, the porous structure includes a plurality of pores or cavities that have an average pore size and that have substantially the same pore size. For example, a substantially portion, substantially all, or all of the plurality of pores can have a pore size that is less than ten times the average pore size and that is greater than one-tenth the average pore size. In other examples, a substantially portion, substantially all, or all of the plurality of pores can have a pore size that is less than twice the average pore size and that is greater than one-half the average pore size or a pore size that is less than 110 percent of the average pore size and that is greater than 90 percent of the average pore size.

[0058] In further embodiments, the pores or cavities comprise a substantial portion of the volume of the porous structure or body. For example, the pores can comprise at least about 20 percent of the volume of the body, at least about 50 percent of the volume of the body, at least about 80 percent of the volume of the body, or at least about 90 percent of the volume of the body.

[0059] In certain embodiments, a carbon electrode 100 is formed with a base 105 and one or more sheets 110 attached to the base 105 as illustrated in FIG. 1. The sheets 110 can be substantially parallel to one another, and the base 105 can be substantially perpendicular to the sheets 110. FIG. 2 illustrates the carbon electrode 100 of FIG. 1 with a separator 205 and a second electrode 210. The separator 205 can be deposited or mechanically placed on the carbon electrode 100 surface. The second electrode 210 is located on or near the surface of the separator 205. For example, the second electrode 210 can be deposited onto the separator 205. Alterna-

tively, the second electrode 210 can be mechanically located on the separator 205. In certain embodiments, the second electrode 210 can include a base and one more sheets similar to the carbon electrode 100. For example, the second electrode 210 can be a second carbon electrode. The second electrode sheets can be inserted in between the sheets 110 of the carbon electrode 100. An electrolyte can be used in addition to the separator 205 or instead of the separator 205. In addition, the carbon electrode and second electrode can be interchanged. In certain embodiments, the carbon electrode 100 is formed from a precursor. The precursor can be any polymer precursor that can be converted to electro-chemically active carbon. For example, polyimide can be used as the precursor. The polyimide precursor can be any commercially available polyimide precursor (e.g., Kapton H N from Dupont, Upilex S from UBE). In certain embodiments, the precursor includes additional additives such as silicon, silica, titanium oxide, etc. The additional additives can change electronic characteristics such as storage capacity, range of voltage span, etc. In certain embodiments, the sheets 110 are about 0.5 to 3 mils (about 12.7 to 76.2 μm) thick. In further embodiments, the sheets 110 are about 1 to 2 mils (about 25.4 to 50.8 μm) thick.

[0060] FIGS. 3A-D illustrate an embodiment of a method of forming a carbon electrode 100. The carbon electrode 100 is formed by stacking two or more sheets 110 with a removable layer 305 between the sheets 110, as illustrated in FIG. 3A. As illustrated in FIG. 3B, a base 105 is then attached to one side of the stacked sheets 110 and removable layers 305. In certain embodiments, the stacked sheets 110 and removable layers 305 are substantially perpendicular to the base 105. The base 105 can be attached to the stacked sheets 110 and removable layers 305 with an attachment substance 310. The attachment substance 310 can be placed on either the base 105 or the stacked sheets 110 and removable layers 305 prior to attaching them. The attachment substance 305 can be a precursor. The precursor can be any polymer precursor that can be converted to electro-chemically active carbon. For example, polyimide, epoxy, etc. can be used as the precursor. In certain embodiments, the attachment substance 310 is a liquid precursor such as a liquid polyimide precursor. The attachment substance 305 can be a similar precursor as the other components (e.g., sheets 110, base 105) of the carbon electrode 100. The liquid polyimide precursor can be any commercially available polyimide precursor (e.g. PI-5878G from HD MircoSystems, etc.).

[0061] In certain embodiments, the stacked sheets 110, removable layers 305, base 105 and attachment substance 310 are exposed to elevated temperatures. Exposing the sheets 110, base 105 and attachment substance 310 to elevated temperatures can pyrolyse the precursors. For example, pyrolysis can be performed at a temperature near the decomposition temperature of the precursor. In certain embodiments, after pyrolysis, the sheets 110, base 105 and attachment substance 310 becomes a monolithic structure or material 315 as illustrated in FIG. 3C. In certain embodiments, the sheets 110 and base 105 were pyrolysed prior to assembly, and the attachment substance 310 is pyrolysed after assembly. In certain embodiments, the sheets 110, base 105 and attachment substance 310 are pyrolysed after assembly. In certain embodiments, the attachment substance 305 is a bonding substance. For example, the attachment substance 305 bonds (e.g. chemically bonds, etc.) with carbon and/or precursor components to form a monolithic carbon electrode.

In certain embodiments, the attachment substance **305** has a substantially similar pyrolysis rate and dimensional change as the other components of the carbon electrode **100**.

[0062] The removable layer **305** can be any material that is removable from the monolithic structure **315**. For example, the removable layer **305** can be dissolved, reacted, melted, etc. In certain embodiments, the removable layer **305** is removed after pyrolysis of the sheets **110**, base **105** and attachment substance **310**. As illustrated in FIG. 3D, after the removable layer **305** is removed, a carbon monolithic structure **315** remains that resembles the carbon electrode **100** in FIG. 1.

[0063] FIGS. 4A-E illustrate another embodiments of a methods of forming a carbon electrode **100**. In certain embodiments, a monolithic structure **315** is formed without using removable layers **305** by stacking sheets **110**. The sheets **110** are staggered relative to adjacent neighboring sheets **110**, as illustrated in FIG. 4A. As illustrated in FIG. 4B, a base **105** is attached to each set of offset sheets **110**. Each base **105** that is attached to each set of offset sheets **110** can be attached with an attachment substance **310** as described above. The entire assembly can then be heated to pyrolyse the precursors. In certain embodiments, pressure **405** can be applied perpendicular to the sheets **110** during pyrolysis, as illustrated in FIG. 4C. Pressure **405** can help to keep the sheets **110** straight and flat. After pyrolysis of the precursors, two monolithic structures **315a**, **315b** are formed, and the monolithic structures **315a**, **315b** can be subsequently separated. In certain embodiments, inserts **410** are placed between one or more sheets **110**, as illustrated in FIG. 4E. The thickness of the inserts **410** can be adjusted to so that the desired thickness of the sheets **101** and the spacing between the sheets **101** can be achieved. In certain embodiments, the inserts **410** can be removed during or after pyrolysis. In certain embodiments, the inserts **410** can be any material and be removed in a similar way that of a removable layer **305** described above.

[0064] Typically, an electrically conductive tab is connected to each electrode. A metal sheet (e.g., metal foil) can be attached to the bottom of the base **105** to make a good electrical contact with the electrically conductive tab. The metal sheet thickness can be selected for appropriate power of the battery and to adequately conduct electrons to and from the electrode. The metal sheet typically has a coefficient of thermal expansion greater than carbon and precursors. If the metal sheet is deposited on the base **105** prior to pyrolysis, during pyrolysis, the expansion of the metal sheet can place a force on the precursors and cause failure (e.g., fracture) of the carbon. In addition, the expansion of the metal sheet and failure of the carbon can occur during any type of elevated temperature and not just during pyrolysis. One way to reduce the force the metal sheets place on the precursors is to have the metal sheet include a porous structure. For example, the metal sheet **505** can have a mesh structure with holes or voids **510** in the metal film (e.g., expanded metal foil), as illustrated in FIG. 5. The porosity in the metal sheet allows the metal sheet to expand locally, thereby reducing the force placed on the carbon and precursors during expansion. In one embodiment, a metal sheet **505** with a mesh structure is formed by first forming slits **605** in a metal sheet **505**, as illustrated in FIG. 6A. A force **610** is then used to pull and deform the metal sheet **505**, as illustrated in FIG. 6B. In certain embodiments, the slits are substantially parallel to one another, and the force that is used to pull the metal sheet is substantially perpendicular to the slits. The force deforms the metal sheet **505** and pulls

the slits **605** open to form holes or voids **510** in the metal sheet **505**. The metal sheet **505** can then be attached to the bottom of the base **105**. For example, the metal sheet **505** can be attached with an attachment substance **310** (e.g. liquid precursor, etc.) as discussed above. After pyrolysis, the metal film will typically make a good electrical contact with the base **105**. An electrically conductive material can be attached to the metal sheet **505** to form the electrically conductive tab.

[0065] In certain embodiments, the carbon electrodes **100** can be stacked. For example, two carbon electrodes **100** can be stacked, as illustrated in FIG. 7. The bottom of the base **105** of each carbon electrode **100** is placed in electrical contact with the other one. An electrically conductive tab **705** can be placed between each carbon electrode **100**. A second electrode **210** can then be placed around each of the carbon electrodes **100**. The second electrodes can also be attached to an electrically conductive tab **710**.

[0066] Carbon electrodes **100** can be made into many different types of structures. For example, a carbon electrode can be porous (e.g., pores, holes, voids). In certain embodiments, the pores have shapes like columns, quasi-columns, cylinders or quasi-cylinders. In certain embodiments, the pores are substantially uniform in shape and/or size. In certain embodiments, the pores are not uniform in shape and/or size. In certain embodiments, a carbon electrode includes a first surface and a second surface on an opposite side as the first surface. The carbon electrode can include a cellular structure. The cellular structure can include a plurality of elongated pores. The plurality of elongated pores can be substantially perpendicular to the first surface and the second surface, and the plurality of elongated pores can be open on the first surface and/or the second surface. In certain embodiments, the plurality of elongated pores are substantially closed other than being open on the first surface and/or the second surface. In certain embodiments, a substantial number of the plurality of elongated pores are open on the first surface and the second surface.

[0067] In certain embodiments, an accordion structure can be used as the carbon electrode **100**, as illustrated in FIG. 8A. The accordion structured carbon electrode **100** can be formed by laying down substantially parallel lines of an attachment substance **310** (e.g., liquid precursor) on a sheet **805**, as illustrated in FIG. 8B. In certain embodiments, the sheet **805** is a precursor sheet. As described above, the precursor can be any polymer precursor that can be converted to electro-chemically active carbon. In alternative embodiments, the sheet **805** is a carbon sheet. Another sheet **805** is placed on the attachment substance **310**. Alternating sheets **805** and attachment substance **310** can be stacked. In certain embodiments, two or more sheets **805** are stacked with one or more lines of the attachment substance **310** between. In certain embodiments, the lines of the attachment substance **310** are staggered for each alternating sheet **805**. For example, the lines of the attachment substance **310** can be about midway between the lines of the attachment substance **310** on neighboring layers. In certain embodiments, the sheets **805** are precursor or carbon sheets that can be deformed to some extent before they fail. As illustrated in FIG. 8C, a force **810** can be used to pull the sheets **805** apart. The force **810** can include a force substantially perpendicular to the sheets **805**. The locations or areas of the sheets that are not attached to one another by the attachment substance **310** are pulled apart resulting in a porous structure. For example, the porous structure illustrated in FIG. 8C is an accordion structure. The porous structure is

pyrolysed to form a carbon electrode **100**. In certain embodiments, the force **810** applied to the sheets **805** is applied during pyrolysis. For example, pins can be placed in the spaces between the sheets and between the attachment substance **310** to prevent the sheets **805** from elastically coming together before the sheets **805** and attachment substance **310** are pyrolysed. In certain embodiments, pyrolysis converts the sheets **805** of precursor into carbon sheets, and the carbon sheets can retain the porous structure without the force **810** applied.

[0068] In certain embodiments, the carbon electrode **100** has a honeycomb structure, as illustrated in FIG. 9A. The honeycomb structure can be formed similar to the accordion structure. For the honeycomb structure, the lines of the attachment substance **310** are thicker. In certain embodiments, the line thickness **905** of the attachment substance **310** is about one-third the distance **910** between the adjacent attachment substance **310** lines. Furthermore, similar to the construction of the accordion structure, the lines of the attachment substance **310** can be about midway between the lines of neighboring layers. For example, the line thickness **905** and the distance **915** from lines of neighboring layers can be about the same. Similar to the construction of the accordion structure, a force **810** can be applied to the sheets **805** to form the porous honeycomb structure. Additional porous structures can be formed by changing the line thickness **905**, distance **910** between adjacent attachment substance **310** lines, and distance **915** between attachment substance **310** lines of neighboring layers. For example, the distance **910** between adjacent attachment substance **310** lines can be increased or decreased to increase or decrease the size of the pores, respectively.

[0069] In certain embodiments, the carbon electrode **100** has a square or rectangular structure, as illustrated in FIG. 10A. In certain embodiments, each sheet **805** is formed into a step formation as illustrated in FIG. 10B. Lines of the attachment substance **310a** can be placed at the edge of each step so that the adjacent sheet **805** can be attached to form a square or rectangular structure. Alternatively, the entire sheet **805** can be coated with the attachment substance **310b** and an adjacent sheet **805** can be attached to make the square or rectangular structure. If the sheet **805** is coated with the attachment substance **310b**, only locations or areas of a sheet **805** that are contacted to the attachment substance **310b** are attached. If only the edge of each step is contacted with an adjacent sheet **805**, the square or rectangular structure can be formed. In certain embodiments, after the sheets **805** are attached, the square or rectangular structure can be pyrolysed to form a monolithic material.

[0070] In certain embodiments, the carbon electrode **100** has a folded-sheet (e.g., folded-film) structure as illustrated in FIG. 11A. Each sheet **805** can be folded to form peaks, as illustrated in FIG. 11B. Similar to the square structure, attachment substance **310a** can be placed at contact areas between the sheets **805** or the entire sheet can be coated with the attachment substance **310b**. For example, the attachment substance **310a** can be placed at each peak or on either side of a sheet **805**. If the peaks of one sheet **805** are contacted to another sheet **805**, the sheets will be attached to one another by those points of contact. In certain embodiments, the peak of each fold contacts about in the middle of or midway between each fold of the neighboring sheet **805**.

[0071] In certain embodiments, the carbon electrode **100** is formed of sheets **805** and spacers **1205**, as illustrated in FIG.

12. Spacers **1205** can be placed between each sheet **805**. In certain embodiments, the spacers **1205** are substantially parallel to each other. The spacers **1205** can be of different shapes and sizes. For example, the spacers **1205** can be wires or tubes. The spacers **1205** can be any material that the sheet **805** can be made of such as polyimide. The spacers **1205** can be attached to the sheets with an attachment substance **310**. In certain embodiments, the spacers **1205** can be an attachment substance **310**. For example, the attachment substance **310** can be applied sufficiently thick so as to create spaces or voids between the sheets **805**. In certain embodiments, each spacer **1205** is placed about midway between spacers **1205** on neighboring sheets **805**.

[0072] In certain embodiments, the carbon electrode **100** is formed into a ribbon candy structure, as illustrated in FIG. 13. The ribbon candy structure can be formed by compressing with a force **1305** on a pleated sheet **805**. In certain embodiments, the force **1305** is applied substantially perpendicular to the pleats of the sheet **805** and substantially parallel to the length of the pleated sheet **805**. When the pleated sheet **805** is compressed, the sharp angles of the pleats **1310** tend to round out and at least a portion of the pleated sheet **805** contacts at least another portion of the pleated sheet **805** to form a ribbon candy structure. The distance between pleats **1310** and the thickness of the sheet **805** can be adjusted to form a desired ribbon candy structure. In certain embodiments, a 1 mil sheet **805** can have a distance of about 3 to 7 mils between pleats **1310**. The combination of the thickness of the sheet **805** and the distance between pleats **1310** can be optimized. For example, if they are not optimized, the contact areas of the sheet **805** on itself can become too large. In certain embodiments, an attachment substance **310** can be used to re-enforce the contact areas of the sheet **805** on itself. For example, the sheet **805** can be coated with the attachment substance **310**. In certain embodiments, an attachment substance **310** is not used. The sheet **805** contact areas or locations advantageously decrease electron travel distance. In certain embodiments, two or more ribbon candy structures can be attached to form a larger carbon electrode **100**. For example, as illustrated in FIG. 13C, two ribbon candy structures can be attached side-by-side. In certain embodiments, two or more ribbon candy structures can be stacked on top one another. An attachment substance **310** can also be used to attach the two or more ribbon candy structures together. For example, a liquid polyimide precursor can be used as an attachment substance **310**. A conductive sheet (e.g., metal) can be electrically attached to any exposed surface of the carbon electrode **100**. For example, a conductive sheet can be electrically attached to the top or the sides of a structure. A conductive film can be electrically attached to any of the structures illustrated in FIGS. 8-14.

[0073] In certain embodiments, the carbon electrode **100** is formed of alternating flat sheets **805a** and contoured sheets (e.g., wavy sheets) **805b**, as illustrated in FIG. 14. An attachment substance **310** can be used to attach alternating flat sheets **805a** and wavy sheets **805b** by coating the flat sheets **805a** and/or the wavy sheets **805b**. The wavy sheets **805b** can be any shaped contoured sheet. For example, the wavy sheet **805b** can be corrugated or folded. In certain embodiments, the sheets **805** described herein (e.g., FIGS. 8-14) can be any material that forms carbon during pyrolysis. For example, the sheets **805** can be a polyimide such as Upilex, Kapton, Apical, Northon TH, Kaptrex, etc. The pleating and/or folding of sheets **805**, as described above, can be done with typical

commercial pleating equipment. For example, typical pleating equipment can include pleating equipment used to make paper fans, window coverings, etc.

[0074] In certain embodiments, a carbon electrode can be molded into a three dimensional structure. In certain embodiments, the carbon electrode is molded into a structure described herein. The carbon electrode can be molded from and then converted to any electrically conductive electro-active carbon material. In certain embodiments, the carbon electrode is molded from polymer, epoxy, resin, etc. For example, the carbon electrode can be molded from a polymer such as Meldin, Vespel, Plavis, etc. In certain embodiments, a polymer is injected molded. In certain embodiments, two or more chemistries are mixed prior to or subsequently to entering the mold to form a polymer piece. In certain embodiments, the carbon electrode can also be formed from polyimide. The polymer piece can be subsequently pyrolysed to form a carbon electrode **100**. In certain embodiments, the carbon electrode is formed by extruding. The carbon electrode can be extruded into structures such as a tubular structure or honeycomb structure. A tubular structure can include an array of tubes. In certain embodiments, the tubes are at least partially compressed to form an elliptical tubular structure.

[0075] The carbon electrode structures described herein can be used to form an electrode of a battery. In certain embodiments, the carbon electrode structure **1500** can have a separator **1505** deposited on the carbon electrode structure **1500** and a second electrode **1510** deposited on the separator **1505**. FIG. **15** illustrates an example of possible configuration of a carbon electrode **1500**, separator **1505** and second electrode **1510**. The separator **1505** can be a porous material or be deposited as described in U.S. patent application Ser. No. 12/728,157, the entirety of which is hereby incorporated by reference. The separator **1505** can also include an electrolyte.

[0076] In certain embodiments, the second electrode **1510** can be mechanically pushed or deposited into the spaces of the carbon electrode structure **1500**. The second electrode **1510** can fill the entire space of the carbon electrode structure or can be a film (e.g., preformed film, deposited film). In certain embodiments, a second electrode slurry or powder is pushed into the spaces of the carbon electrode structure **1500**. The second electrode slurry or powder can include a mixture of an electrode powder, electrically conductive powder (e.g., carbon black) and binder. In certain embodiments, the mixture includes a solvent such as NMP (e.g., N-Methylpyrrolidone). The second electrode slurry or powder can be pushed into the spaces of the carbon electrode structure **1500**. If the second electrode is a slurry, it can be dried, cured and/or set. If the second electrode is a powder, it can be cured and/or set. In certain embodiments, the separator electrically separates the carbon electrode structure **1500** and the second electrode **1510**. As discussed above, the second electrode can be any can be any type of electrode that is compatible with the carbon electrode.

[0077] In certain embodiments, the carbon electrode describe herein can be used with commercially available materials. For example, a commercially available separator **1605** and second electrode **1610** can be used with a corrugated carbon electrode sheet **805**, as illustrated in FIG. **16**. In certain embodiments, a commercially available separator and second electrode can be used with the carbon electrode **100** illustrated in FIG. **1**. An electrolyte can also be used with the separator **1605**. Commercially available separators can include porous polyethylene and polypropylene films, and

commercially available second electrodes can include electro-chemically active material layers on metal films (e.g., copper, aluminum).

[0078] Various embodiments have been described above. Although the invention has been described with reference to these specific embodiments, the descriptions are intended to be illustrative and are not intended to be limiting. Various modifications and applications may occur to those skilled in the art without departing from the true spirit and scope of the invention as defined in the appended claims.

What is claimed is:

1. An electrode comprising:
 - a body of material formed in substantial part of carbon, the body having an exterior surface and an interior located within the exterior surface;
 - a plurality of cavities located in the interior of the body, each of the cavities in communication with the exterior of the body, each of the cavities having an interior surface; and
 - wherein the cavities each being sized to accommodate a battery separator located therein and substantially covering the interior surface of the cavity while still permitting sufficient room for a second electrode material to be located within the cavity spaced from the interior surface of the cavity by the separator.
2. The electrode of claim 1, wherein the cavities are substantially regularly spaced.
3. The electrode of claim 1, wherein the body comprises a volume and the cavities comprise at least 50 percent of the volume.
4. An electrode for a battery comprising a structure having a plurality of engineered cavities and having a composition comprising carbon that is electrochemically active.
5. The electrode of claim 4, wherein the structure consists essentially of electrochemically active material.
6. The electrode of claim 4, wherein the structure is a monolithic structure.
7. The electrode of claim 4, wherein the carbon is formed from a precursor.
8. The electrode of claim 4, wherein the structure is configured to be an electrochemically active component and a current collector.
9. The electrode of claim 4, wherein the carbon is substantially homogeneous throughout the structure.
10. The electrode of claim 4, wherein the carbon is a substantially continuous phase in the structure.
11. The electrode of claim 4, wherein the structure substantially does not include an inactive binder.
12. The electrode of claim 4, wherein the structure is self-supported.
13. The electrode of claim 4, wherein the electrode is an anode.
14. The electrode of claim 4, wherein the composition comprises silicon.
15. A battery comprising:
 - a first electrode comprising electrochemically active carbon and having a plurality of pores;
 - a separator located within the plurality of pores; and
 - a second electrode located within the plurality of pores, wherein the separator electrically isolates the first electrode from the second electrode.
16. The battery of claim 15, wherein the battery is a lithium ion battery.
17. The battery of claim 15, wherein the first electrode consists essentially of electrochemically active material.

18. The battery of claim **15**, wherein the first electrode is a monolithic structure.

19. The battery of claim **15**, wherein the second electrode comprises a lithiated intercalation compound.

20. The battery of claim **15**, wherein the separator is a deposited layer.

* * * * *