



US 20100237074A1

(19) **United States**

(12) **Patent Application Publication**
Yang et al.

(10) **Pub. No.: US 2010/0237074 A1**

(43) **Pub. Date: Sep. 23, 2010**

(54) **RECEPTACLE WITH MOTION DAMPER**

Related U.S. Application Data

(75) Inventors: **Frank Yang**, Rancho Palos Verdes, CA (US); **Joseph Sandor**, Santa Ana Heights, CA (US); **Chun-Hsien Chen**, Guanmiao Township (TW)

(60) Provisional application No. 61/162,224, filed on Mar. 20, 2009.

Publication Classification

(51) **Int. Cl.**
B65D 43/26 (2006.01)
(52) **U.S. Cl.** **220/262**
(57) **ABSTRACT**

Correspondence Address:
KNOBBE MARTENS OLSON & BEAR LLP
2040 MAIN STREET, FOURTEENTH FLOOR
IRVINE, CA 92614 (US)

A receptacle having one or more lids can be provided one or more dampers configured to slow the movement of the lids from their open position toward its closed position. The lids of the receptacle can have a shape which facilitates dampening of the movement of the lids from an open position to a closed position. The lids and lid portion can have walls which are juxtaposed relative one another in a close relationship such that air briefly retained within the body when the lids are moved from an open position to a closed position.

(73) Assignee: **SIMPLEHUMAN, LLC**, Torrance, CA (US)

(21) Appl. No.: **12/727,954**

(22) Filed: **Mar. 19, 2010**

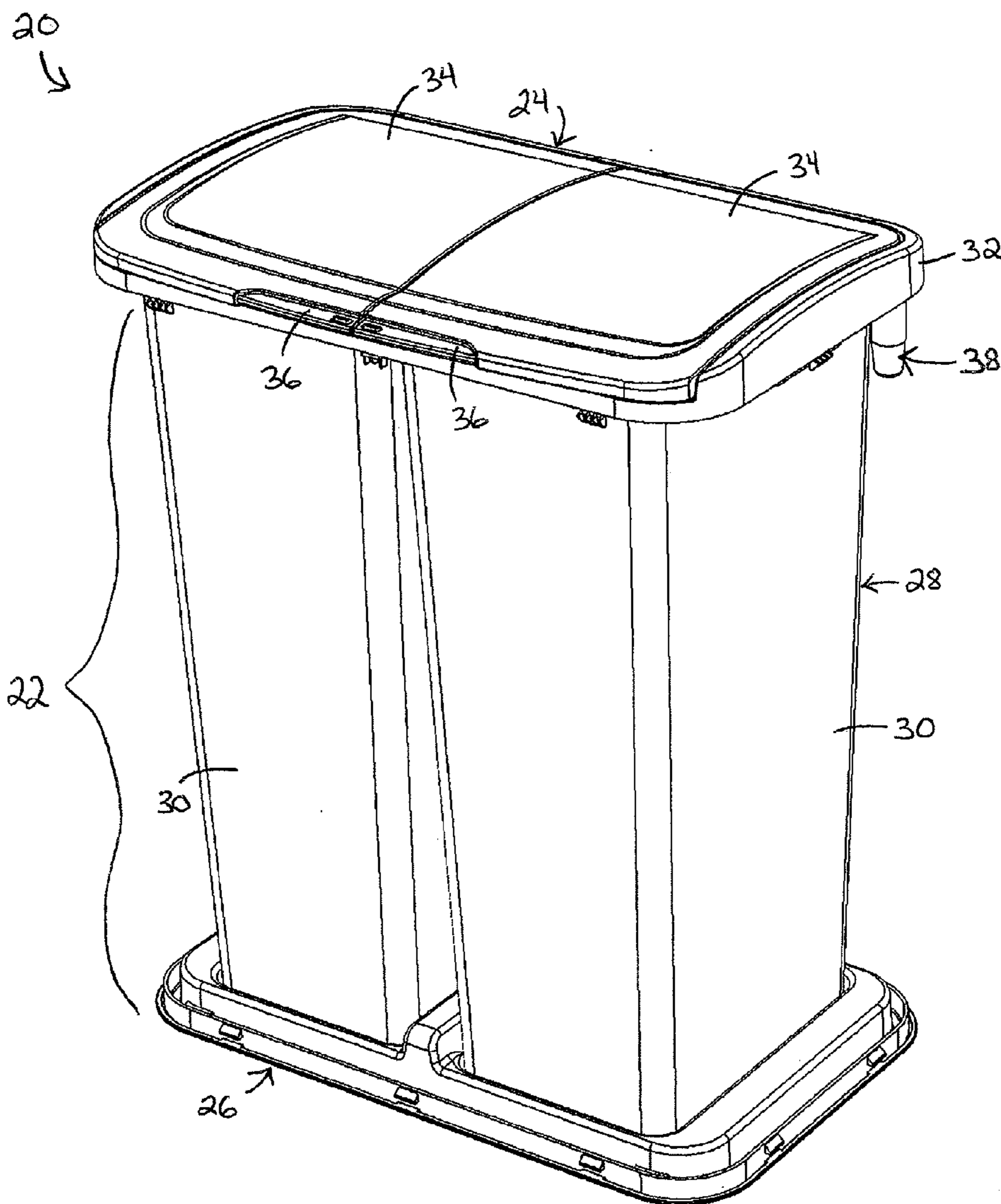

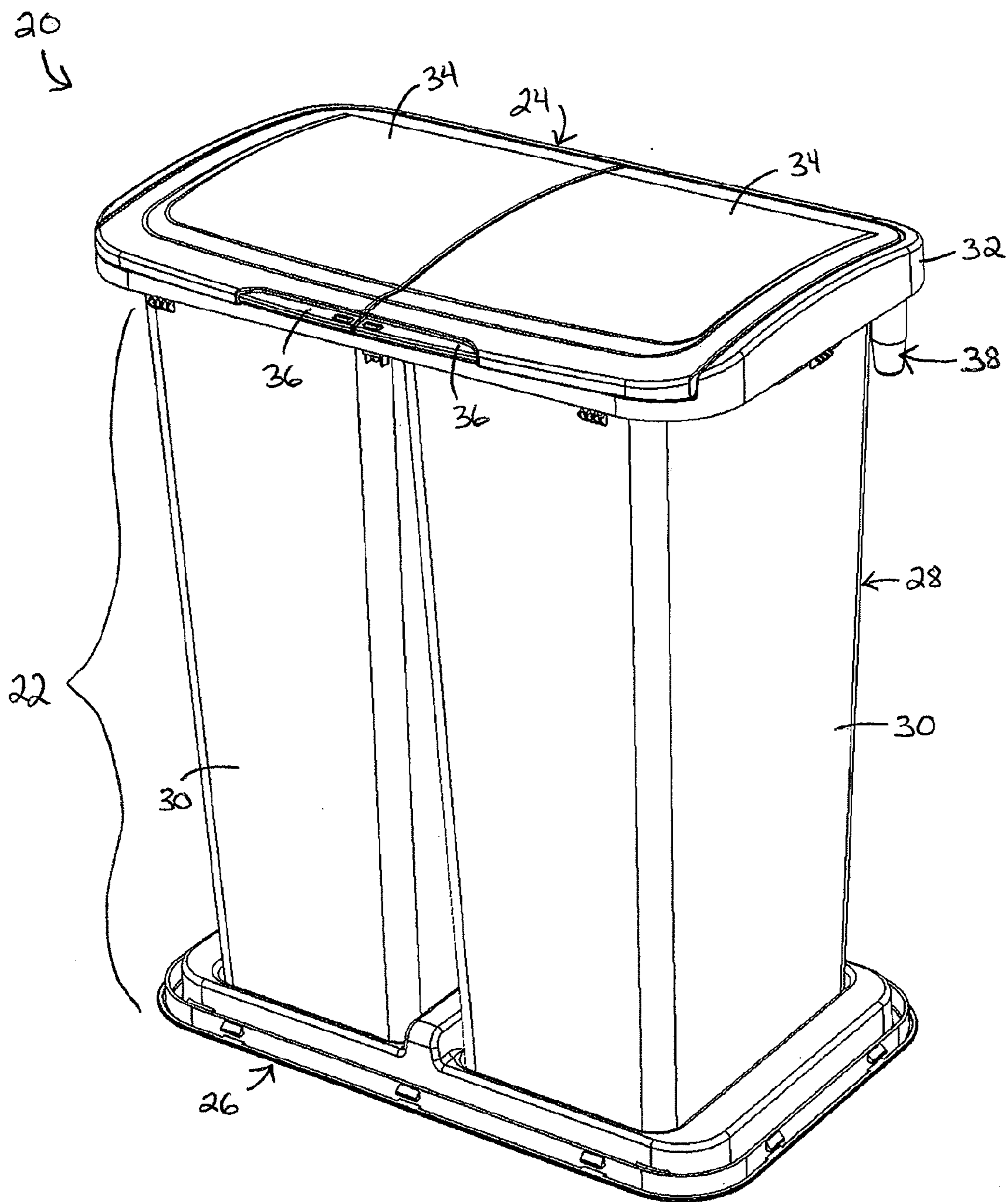

FIG. 1

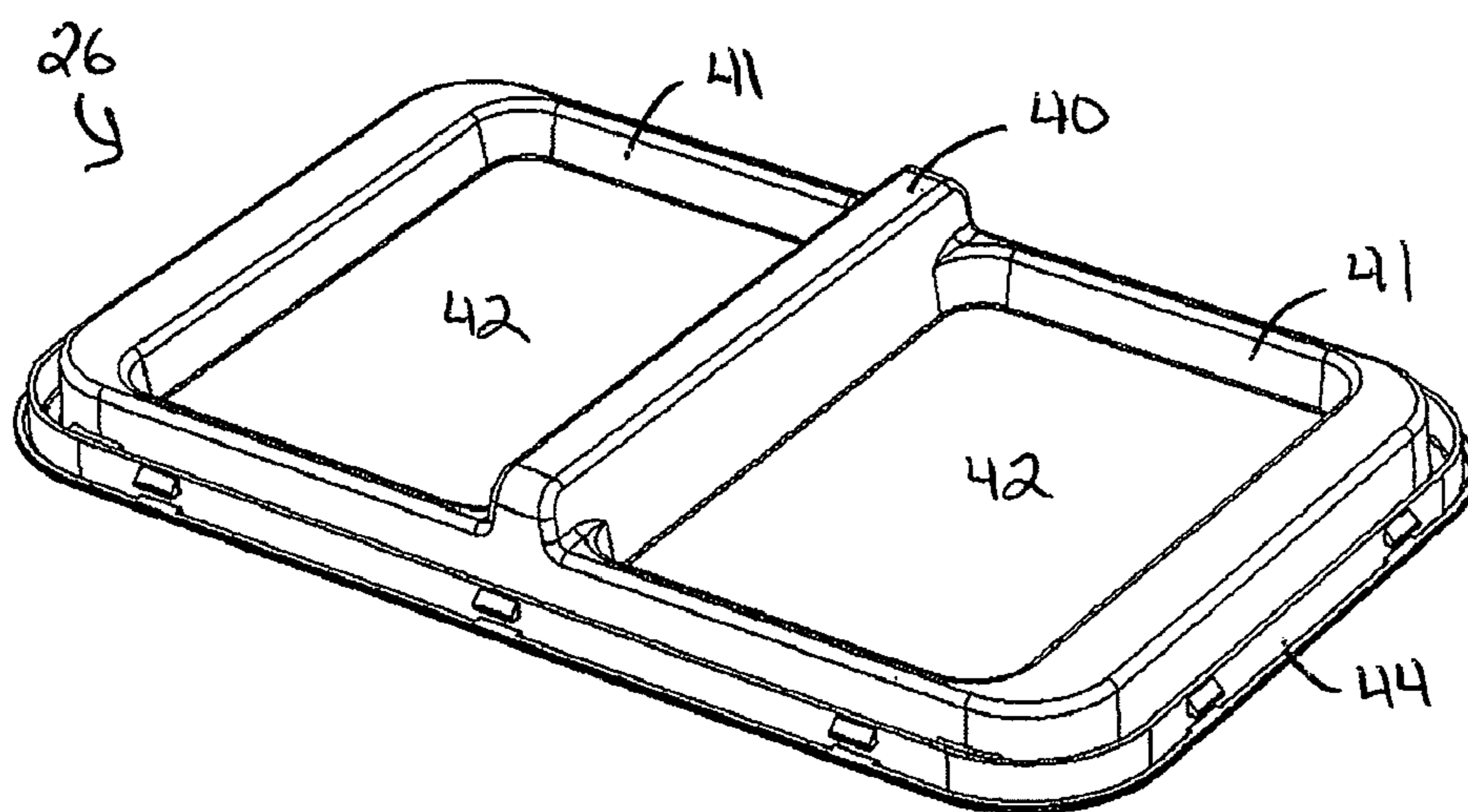
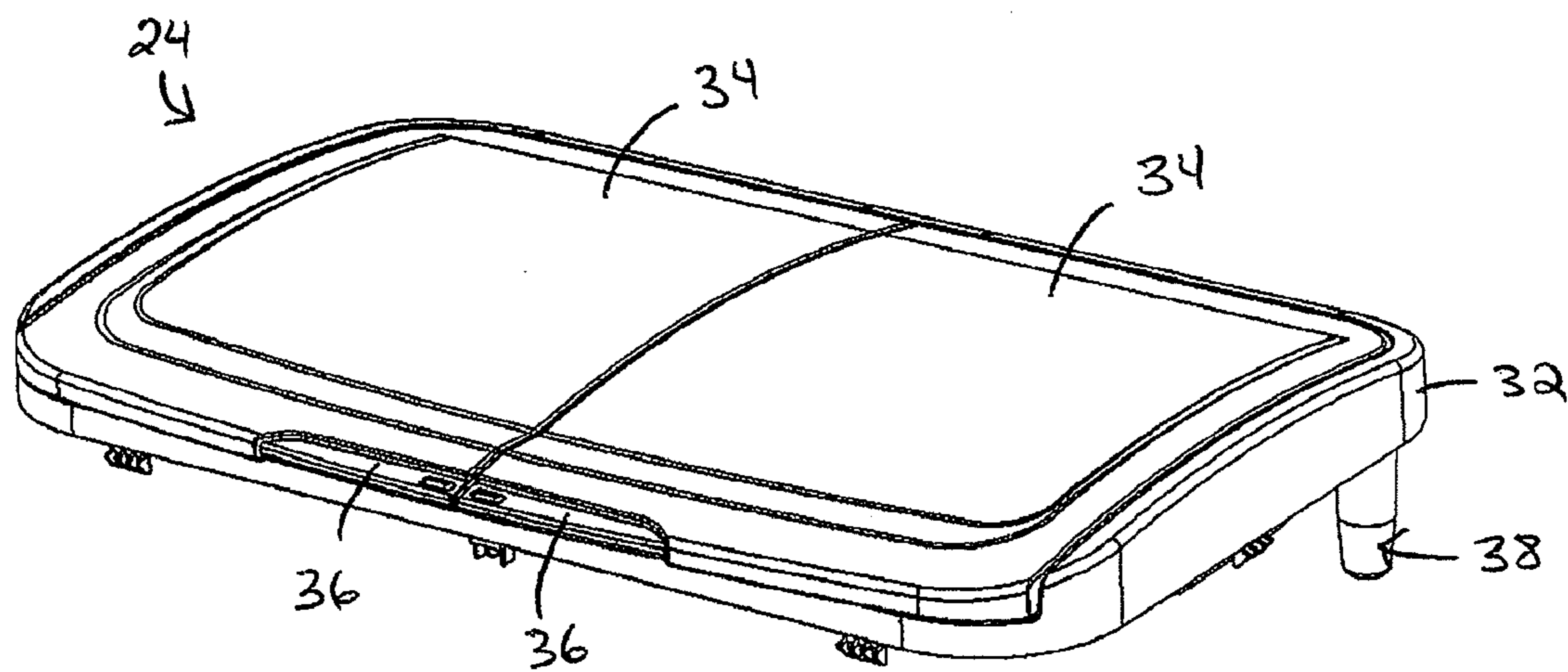

FIG. 2

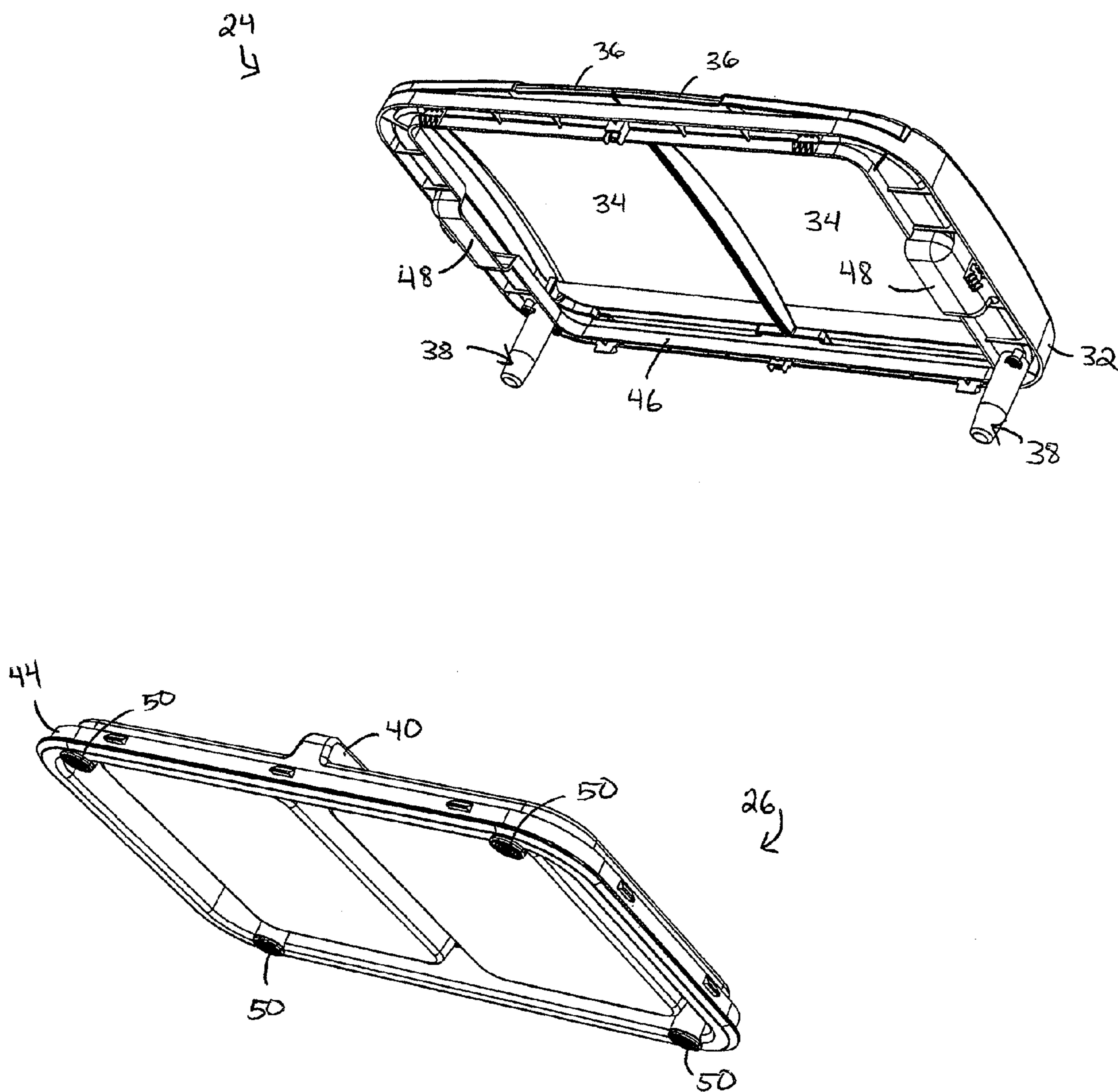

FIG. 3

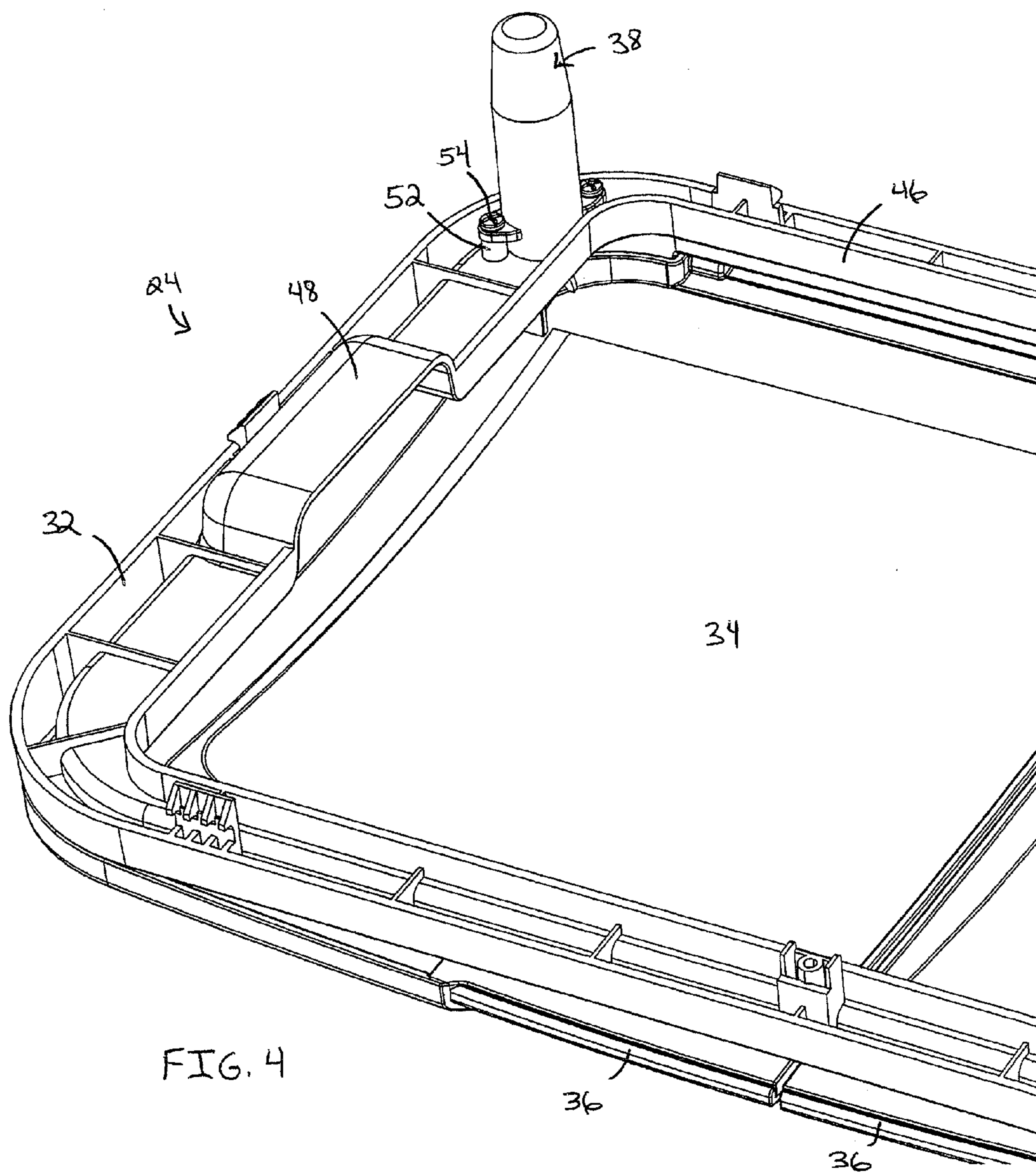

FIG. 4

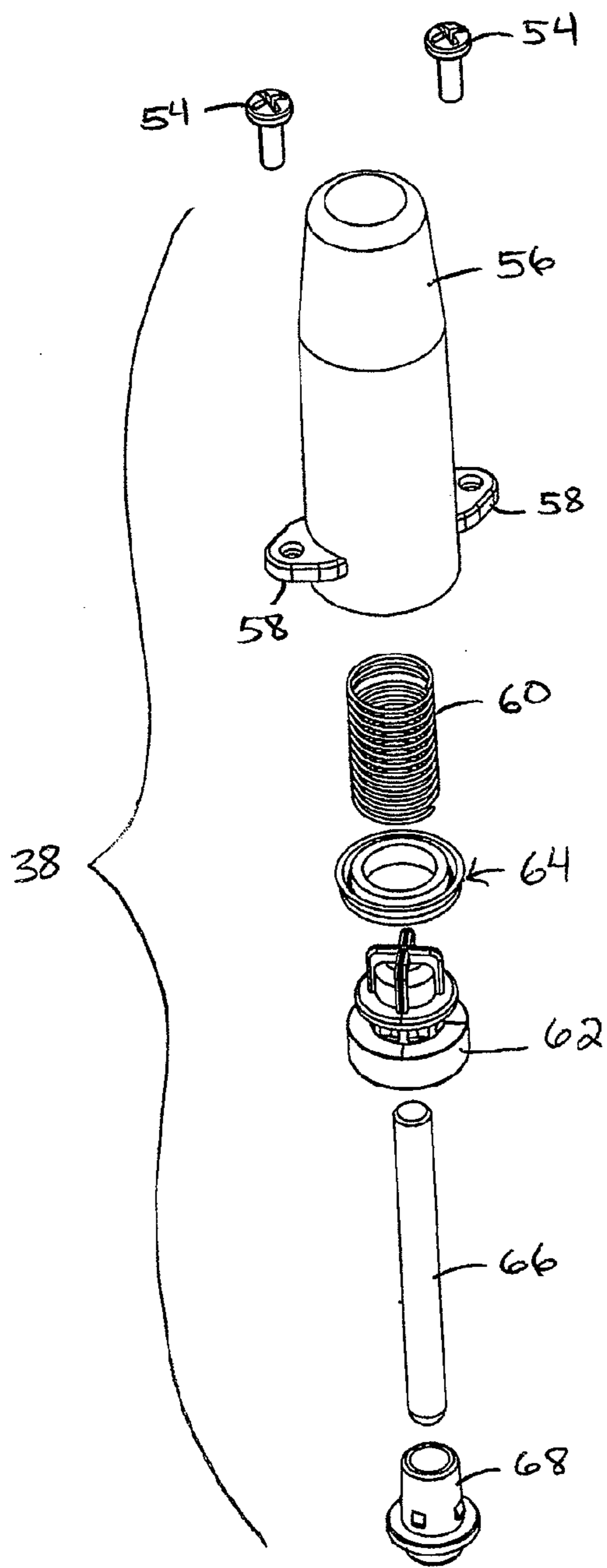
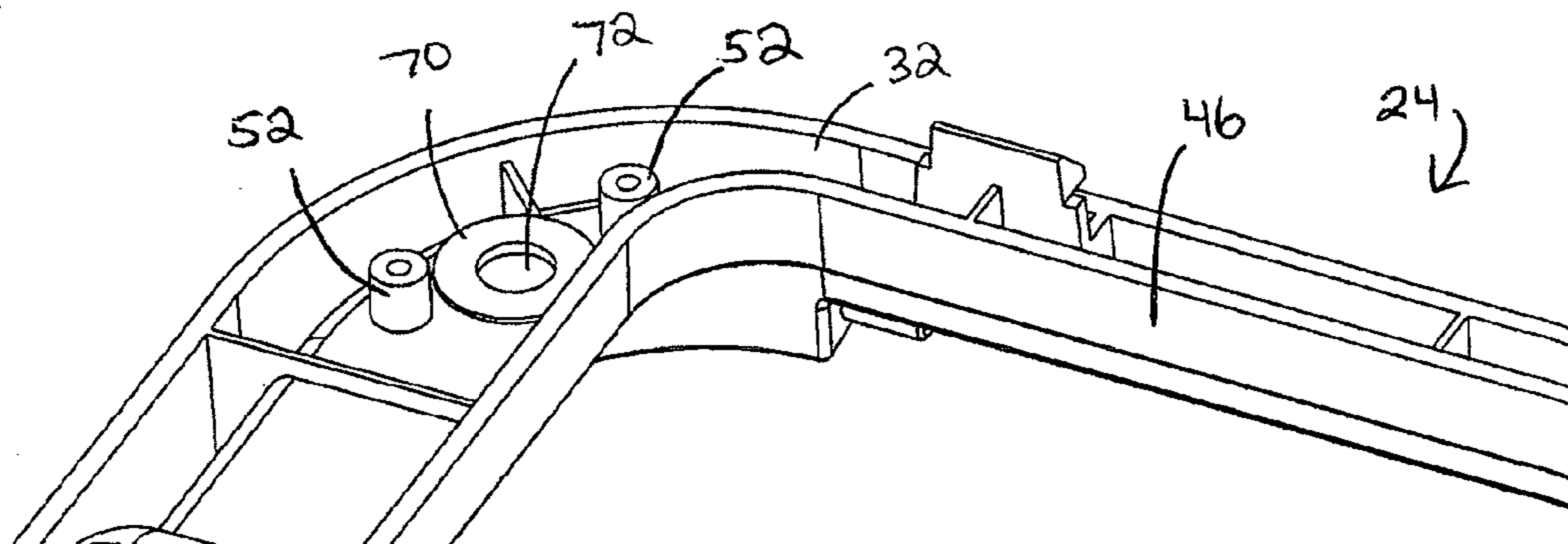

FIG. 5



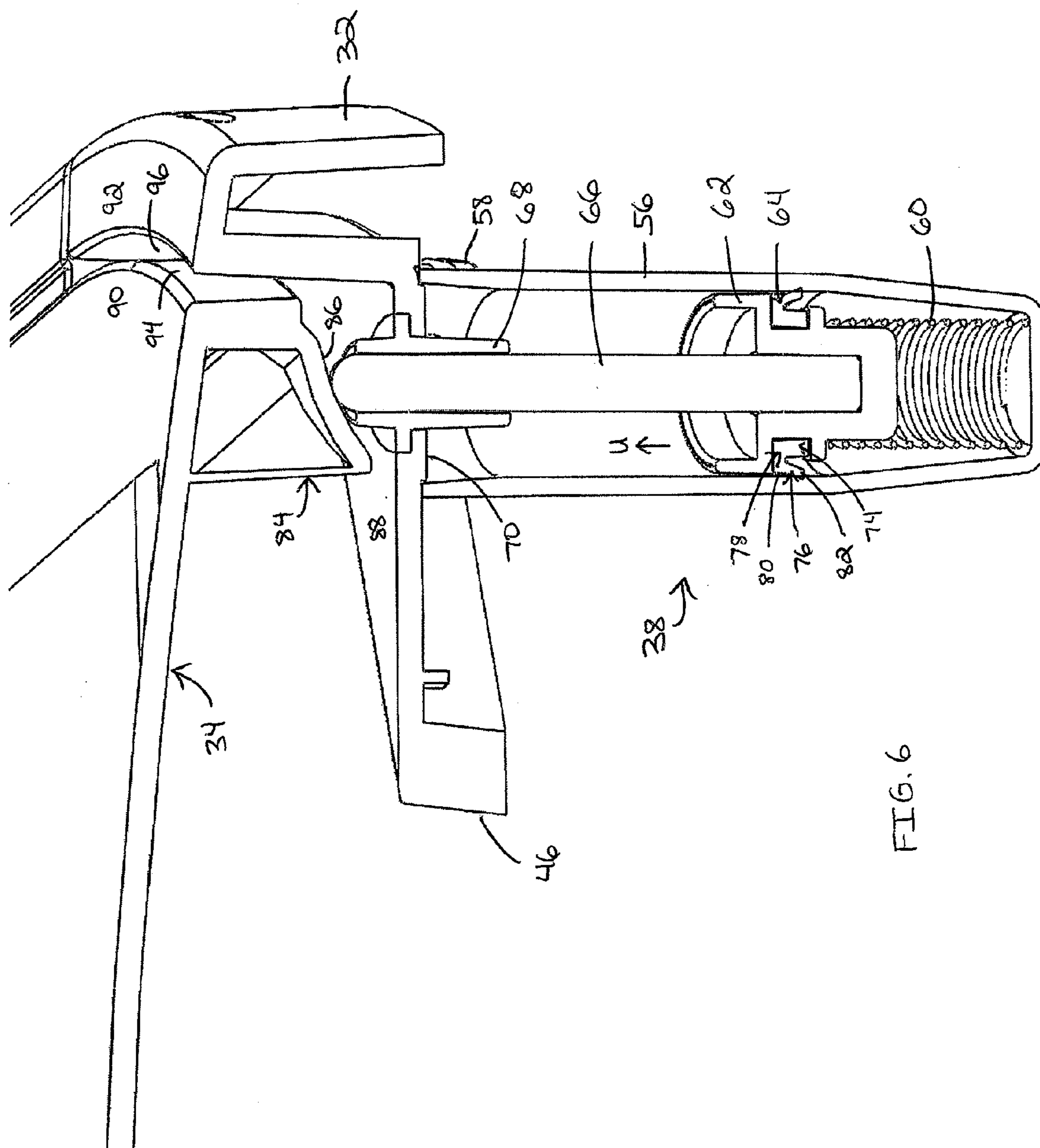

FIG. 6

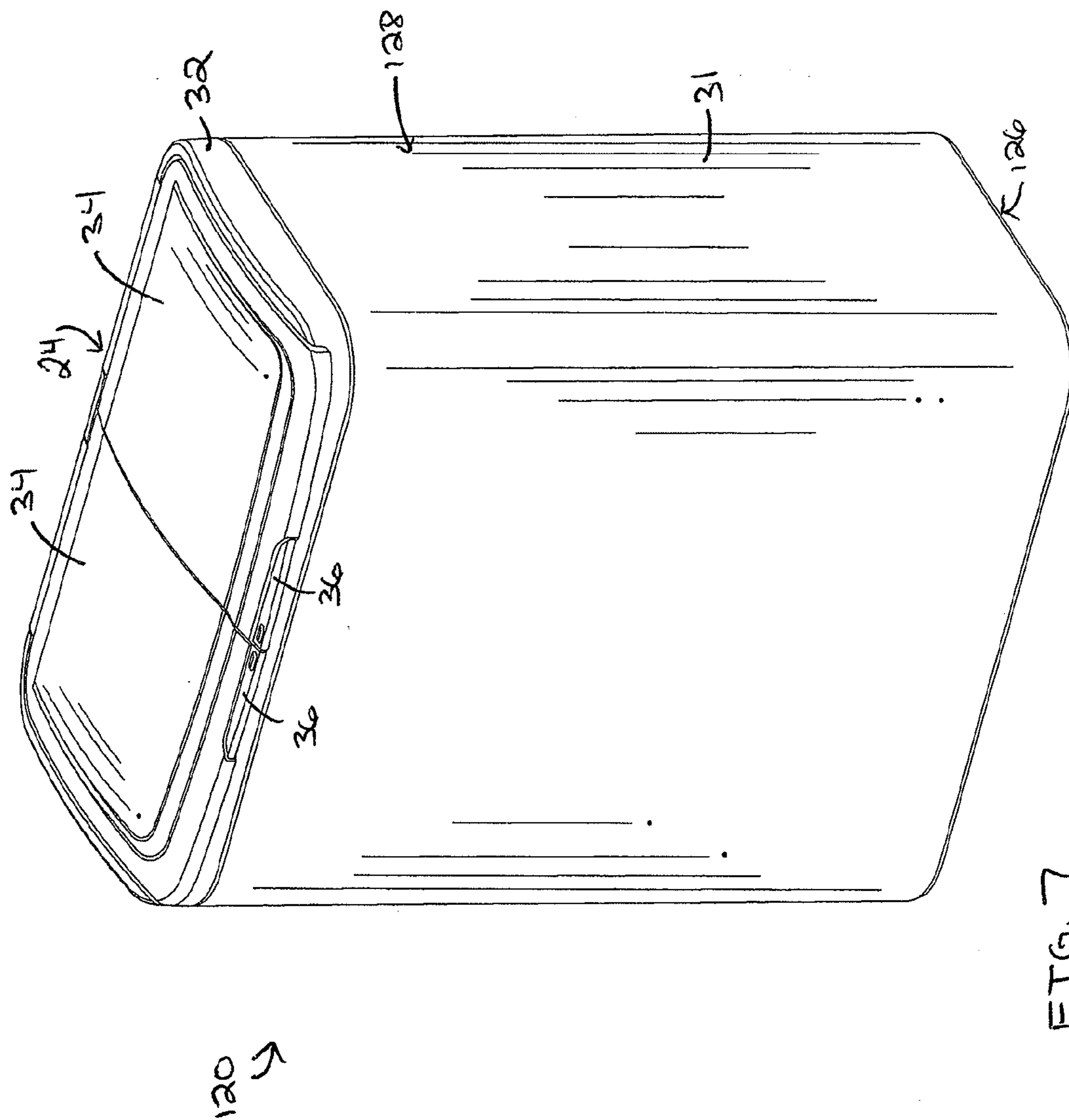
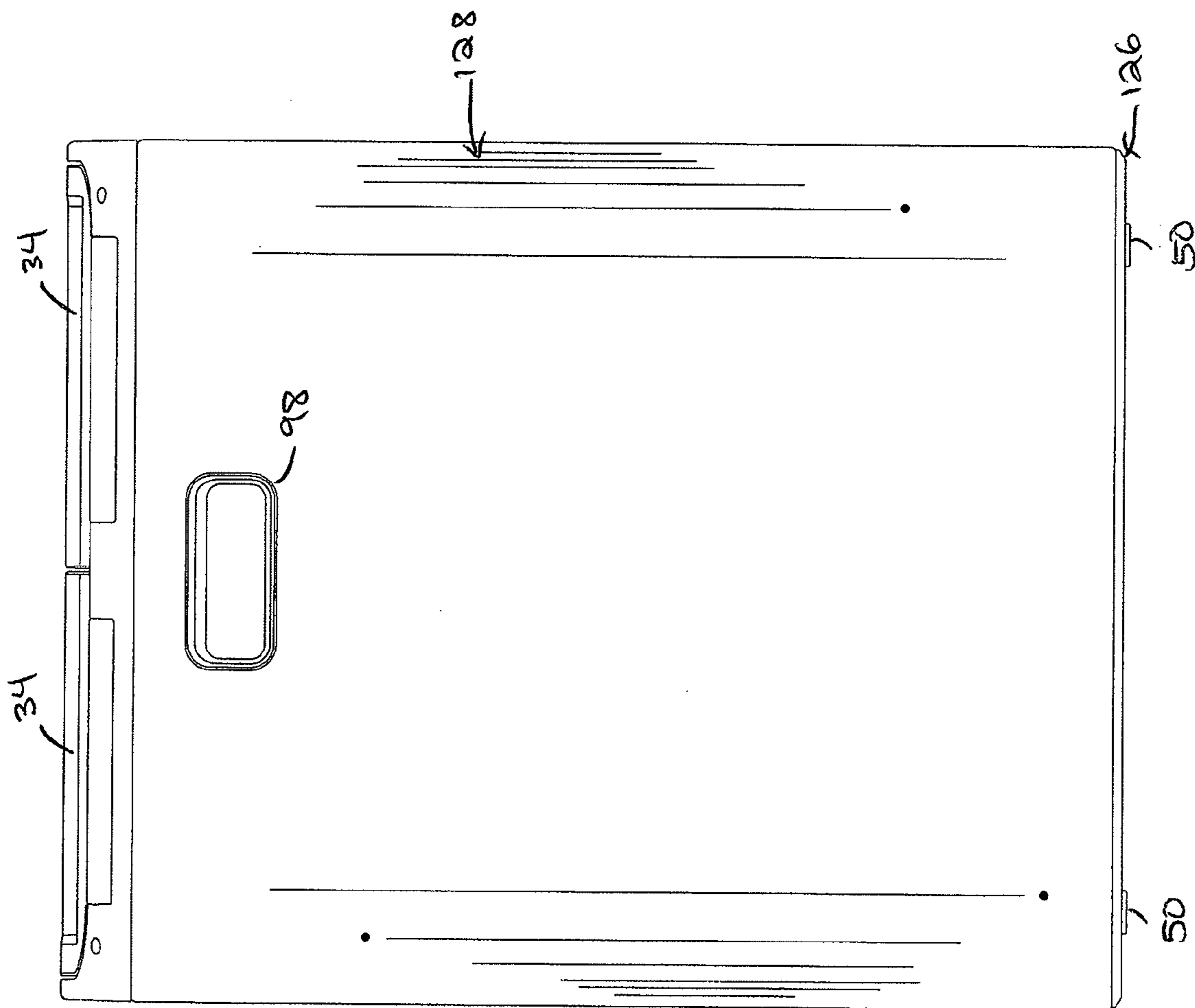

FIG. 7



180 ↗

FIG. 8

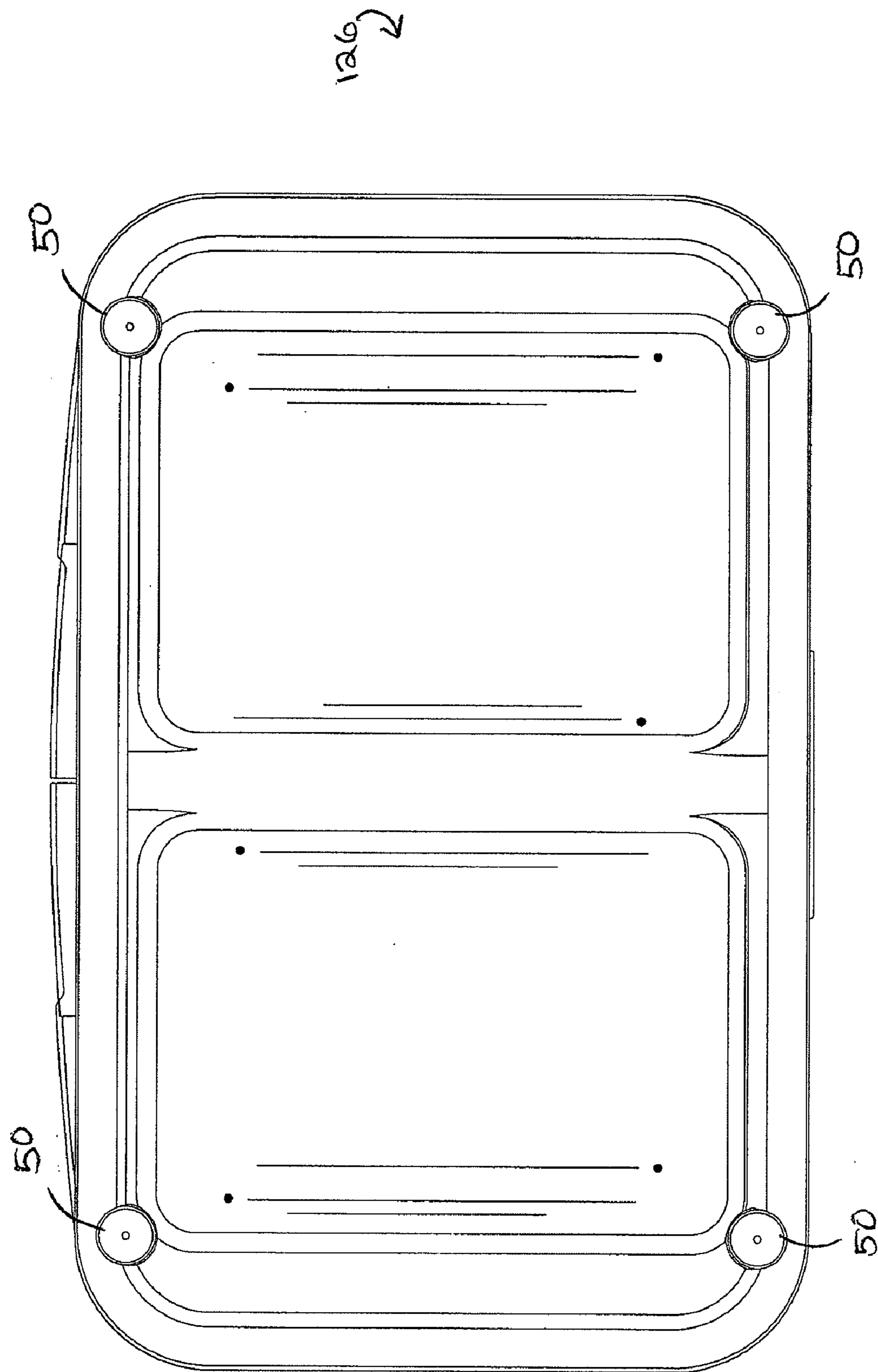
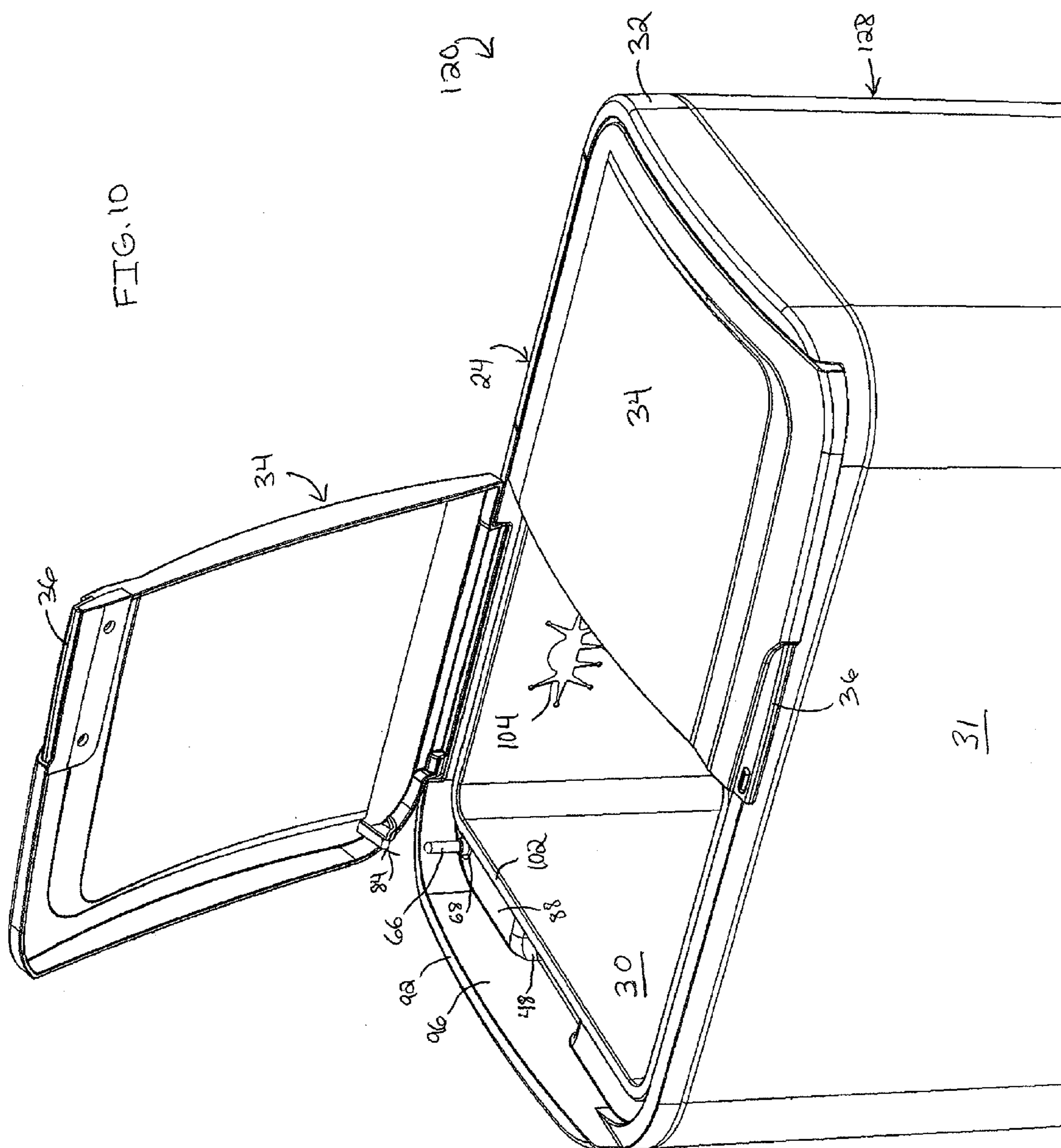

FIG. 9



RECEPTACLE WITH MOTION DAMPER

CLAIM OF PRIORITY

[0001] This application claims benefit under 35 U.S.C. §119(e) to U.S. Provisional Patent Application No. 61/162,224, filed Mar. 20, 2009, which is incorporated in its entirety by reference herein.

BACKGROUND OF THE INVENTIONS

[0002] 1. Field of the Inventions

[0003] The present inventions relate to receptacles having doors or lids, some of the inventions relating to mechanisms configured to slow at least the closing movement of the lids.

[0004] 2. Description of the Related Art

[0005] Receptacles and other devices having lids or doors are used in a variety of different settings. For example, in both residential and commercial settings, trashcans and other devices often have lids or doors for preventing the escape of the contents from the receptacle. In the context of trashcans, some trashcans include lids or doors to hide the trash within the receptacle from view. Additionally, the lid of a trashcan helps prevent contamination from escaping from the receptacle.

[0006] Recently, trashcans with rotary-type motion dampers for slowing the motion of the lids have become commercially available. More specifically, these rotary dampening mechanisms are connected to the lids of the trashcans so as to slow the closing movement of the lids. As such, the trashcan is more aesthetically pleasing because the lid closes slowly, thereby preventing a loud slamming noise when the lid is moved to a closing position.

[0007] These types of trashcans often are pedal-actuated, i.e., they include a foot pedal which is connected to the lid for moving the lid toward the open position. The rotary mechanisms are connected to the internal linkage connecting the foot pedal to the lid so as to slow the closing movement of the lid.

SUMMARY OF THE INVENTIONS

[0008] An aspect of at least one of the embodiments disclosed herein includes the realization that trash receptacles can be configured to use multiple techniques for dampening one or more movements of a lid.

[0009] Thus, in accordance with an embodiment, a trashcan can comprise a body defining an interior space, the body comprising a base portion and an upper body portion. The trashcan can further comprise a lid portion supported by the upper body portion, the lid portion comprising a lid support having an interior peripheral wall and two lids moveably mounted to the lid support so as to be independently moveable between open and closed positions, at least one of the lids having a generally concave profile. The trashcan can further comprise a first motion damper connected to the lid portion, and a second motion damper connected to the lid portion, wherein the first and second motion dampers are configured to dampen a movement of at least one of the two lids from the open position to the closed position. At least one of the two lids can comprise an exterior peripheral wall, the interior peripheral wall of the lid portion and the exterior peripheral wall of the lid being juxtaposed relative one another when the at least one lid is in the closed position so as to trap air within

the lid portion and dampen lid movement when the at least one lid is moving from the open position to the closed position.

[0010] In accordance with another embodiment, a trashcan can comprise a body defining an interior space, the body comprising a base portion and an upper body portion. The trashcan can further comprise a lid portion supported by the upper body portion, the lid portion comprising at least one pivotable lid having a generally concave profile, each lid being independently moveable between open and closed positions such that the generally concave profile of the lid traps air within the interior space when the at least one lid moves from the open position to the closed position.

[0011] In accordance with another embodiment, a trashcan can comprise a body defining an interior space, the body comprising a base portion and an upper body portion. The trashcan can further comprise a lid portion supported by the upper body portion, the lid portion comprising at least one lid moveably mounted to the lid portion so as to be independently moveable between open and closed positions, the lid portion comprising an interior peripheral wall, and at least one of the lids comprising an exterior peripheral wall. The interior and exterior peripheral walls can be positioned adjacent one another when the at least one lid is in the closed position so as to trap air within the lid portion and dampen lid movement when the at least one lid is moving from the open position to the closed position.

[0012] In accordance with another embodiment, a trashcan can comprise a body defining an interior space, the body comprising a base portion and an upper body portion. The trashcan can further comprise a lid portion supported by the upper body portion, the lid portion comprising at least one lid moveably mounted to the lid portion so as to be independently moveable between open and closed positions, the lid portion further comprising an air guide configured to guide air downwardly into the interior space as the at least one lid moves from the open position towards the closed position.

BRIEF DESCRIPTION OF THE DRAWINGS

[0013] The above mentioned and other features of the inventions disclosed herein are described below with reference to the drawings of preferred embodiments. The illustrated embodiments are intended to illustrate, but not to limit the inventions. The drawings contain the following figures:

[0014] FIG. 1 is a top, front, and left side perspective view of a trashcan in accordance with an embodiment, having dual lids with the lids in their closed position, with an exterior shell removed.

[0015] FIG. 2 is a partial exploded and perspective view of the lid portion and base portion of the trashcan illustrated in FIG. 1.

[0016] FIG. 3 is another partial exploded and perspective view of the lid portion and base portion of the trashcan illustrated in FIG. 1.

[0017] FIG. 4 is a partial, enlarged, inverted, and perspective view of a lower side of the lid portion of the trashcan illustrated in FIG. 1.

[0018] FIG. 5 is an enlarged, inverted, exploded, and perspective view of a damping mechanism attached to the lid portion of the trashcan illustrated in FIG. 1.

[0019] FIG. 6 is an enlarged, perspective, and cross-sectional view of the damping mechanism and lid portion illustrated in FIG. 5.

[0020] FIG. 7 is a top, front, and left side perspective view of the trashcan with an optional shell.

[0021] FIG. 8 is a rear elevational view of the trashcan illustrated in FIG. 7.

[0022] FIG. 9 is a bottom plan view of the trashcan illustrated in FIG. 7.

[0023] FIG. 10 is a top, front, and left side perspective view of the trashcan illustrated in FIG. 7, with one of the lids in an open position.

DETAILED DESCRIPTION OF THE PREFERRED EMBODIMENT

[0024] The embodiments of a receptacle with at least one lid are all disclosed in the context of a trashcan. The inventions disclosed herein are described in the context of a trashcan because they have particular utility in this context. However, the inventions disclosed herein can be used in other contexts as well, including, for example, but without limitation, large commercial trashcans, doors, windows, security gates, and other larger doors or lids, as well as doors or lids for smaller devices, such as high precision scales, computer drives, etc.

[0025] FIG. 1 illustrates an embodiment of a receptacle assembly 20. The assembly 20 can include a body portion 22 and a lid portion 24. The body portion 22 can include a base portion 26 and an upper body portion 28. The base portion 26 and the upper body portion 28 can be made from a single monolithic piece or from separate pieces connected together.

[0026] In the illustrated embodiment, the base portion 26 can be configured to support the assembly 20 in a stable resting position when the assembly 20 rests on a surface such as a floor, which may be smooth, or uneven. The base portion 26 can be configured to support the upper body portion 28 such that the upper body portion 28 can extend upwardly from the base portion 26.

[0027] The upper body portion 28 can include at least one container 30 which can be also be referred to as a "bin" or "liner". The at least one container 30 can be configured to define an interior cavity or cavities. In some embodiments, such as illustrated in FIG. 1, the upper body portion 28 comprises two separate containers 30, each defining one cavity. Each of the interior cavities can be configured, for example, to receive and/or support additional rigid trash liners (not shown). In other embodiments, described below with reference to 7-10, an outer shell can enclose the containers 30 between the base portion 26 and the lid portion 24.

[0028] In some embodiments, the containers 30 can be formed from sheet metals, such as sheet stainless steel, or other metals, or other materials including plastics, etc. In some embodiments, when sheet metal is used, such as sheet stainless steel, the containers 30 can be made from any of 23-26 gauge stainless sheet steel. Of course, the thinner the gauge sheet steel, the lighter and less expensive the containers 30 will be.

[0029] The lid portion 24 can comprise a lid support member 32 extending generally around the periphery of the lid portion 24. The lid support member 32 can provide support for and be attached to at least one moveable lid 34.

[0030] The lid portion 24 illustrated in FIG. 1 includes two moveable lids 34 pivotably attached to the lid support member 32. In other embodiments, a single moveable lid 34 can be attached, or more than two moveable lids 34 can be attached. While the moveable lids 34 in FIG. 1 are attached such that they both open in the same direction, in other embodiments

the moveable lids 34 can be attached such that they open in opposite directions from one another. Additionally, while the moveable lids 34 are attached such that they pivot generally about a back edge of the assembly 20, in other embodiments the moveable lids 34 can be attached and/or pivoted about different areas of the assembly 20.

[0031] The moveable lids 34 can be moveably mounted to the lid portion 24 with any known device, such as a hinge which can allow pivoting motion of the moveable lid 34, or other devices providing different movements. The connection between the lid or moveable lids 34 and the lid portion 24 can be constructed, for example, so as to connect the moveable lids 34 to the lid support member 32 or, in some embodiments, directly to the shell or shells 30.

[0032] The lid portion 24 can further comprise a handle or handles 36. The handles 36 can be located generally along a front portion of the receptacle assembly 20, such as illustrated in FIG. 1, or can be placed elsewhere. The handles 36 can comprise recessed areas of the moveable lids 34, and/or protruding portions of the moveable lids 34, such that an operator is able to grab hold of and/or contact the handles 36 to move the moveable lids 34 from a closed position to an open position, the closed position being illustrated in FIG. 1. In some embodiments, the handles 36 can extend from the moveable lids 34 such that a user is able to reach underneath the moveable lids 34 and lift up on the handles 36 to open the moveable lids 34.

[0033] With continued reference to FIG. 1, the assembly 20 can further comprise at least one damper 38. The damper 38 can be attached to the lid portion 24, such that as a moveable lid 34 is moved from an open position to a closed position, the damper 38 is activated and dampens the downward movement of the moveable lid 34, described in greater detail below.

[0034] With reference to FIG. 2, the base portion 26 can be made from a single monolithic piece and/or from separate components connected together. In some embodiments, the base portion 26 includes a divider portion 40. The divider portion 40 can extend from a central area of the base 26. On either side of the divider 40, an internal peripheral wall 41 can extend around a flat, recessed area 42. Each flat, recessed area 42 can be configured to receive a container 30, such that a bottom portion of each container 30 rests flat against the recessed area 42 and is supported by the recessed area 42. In some embodiments a peripheral wall 44 can extend around the divider 40, internal peripheral wall 41, and recessed areas 42.

[0035] With reference to FIG. 3, the lid portion 24 can comprise an interior peripheral wall 46. The interior peripheral wall 46 can extend around a portion of, or the entire, lid portion 24. In some embodiments the interior peripheral wall 46 can also extend along a finger-grip region or regions 48, defined along a side or sides of the lid portion 24. As described further herein, the finger-grip regions 48 can comprise recessed, open areas along the lid portion 24 which provide room for an operator to insert a finger or hand when moveable lid 34 is in an open position, and lift a container 30 upwardly through the lid portion 24, or in other embodiments, lift a liner from within a container 30.

[0036] With continued reference to FIG. 3, in some embodiments, the base portion 26 can comprise at least one anti-sliding mechanism 50 (e.g. legs) sized to stably support the trash can assembly 20 on a flooring surface. In some embodiments, as illustrated in FIG. 3, the anti-sliding mechanism 50 can comprise a contact member made of any rubber,

or other material. The contact member can be made of a material or can include a surface texture that generates appropriate coefficients of friction with the typical flooring materials.

[0037] With reference to FIGS. 4-6, the assembly 20 can include one or more dampers 38. The dampers 38 can be any type of dampening device including, for example, but without limitation, rotary dampening devices, friction dampening devices, or fluid damping devices operating with liquid or gaseous working fluids. Other types of dampening mechanisms can also be used.

[0038] In some embodiments, the assembly 20 can include at least two dampers 38 arranged on opposing sides of the lid support 24 so as to provide independent dampening against the movement of each of the moveable lids 34. The description of the damper 38 set forth below applies to both of the dampers 38, although only one damper 38 and its components are specifically identified below.

[0039] With reference to FIG. 4, the damper 38 can be attached to the lid portion 24 in any known manner. In some embodiments, the damper 38 can be connected to a member or members 52 which extend from a face of the lid portion 24. The damper 38 can be connected to the members 52 with fasteners 54, such as for example small screws. Alternatively, in some embodiments the damper 38 can be integrally formed with the lid portion 24.

[0040] In some embodiments, the damper 38 can be configured to dampen the downward movement of a moveable lid 34. As used herein, the “downward movement” of the moveable lid 34 corresponds generally to the movement from a position of the moveable lid 34 as viewed in FIG. 10 to a position of the moveable lid 34 as viewed in FIG. 1.

[0041] With reference to FIG. 5, the damper 38 can be a fluid type damper operating with air as the working fluid. In the illustrated embodiment, the damper 38 can include a housing 56. The housing 56 can be mounted anywhere on the assembly 20. Further advantages can be provided where, as illustrated in FIGS. 4-6, the housing 56 of the damper 38 can be mounted to the lid portion 24. In some embodiments, the housing 56 can define a cylinder, and can be positioned in an inverted orientation, with the closed end of the cylinder being at the bottom of the damper 38 and the open end facing upwardly.

[0042] The dampening function of the damper 38 can be achieved by way of the resistance of the flow of a fluid, such as air, into and out of the housing 56. Additionally, or alternatively, the dampening function of the damper 38 can be achieved by way of the resistance of a biasing element inside the housing 56. This resistance of flow and/or biasing can generate sufficient damping forces for slowing the closing of the moveable lid 34. Such forces can be large.

[0043] With continued reference to FIGS. 5 and 6, the housing 56 can enclose internal components of the damper 38, and can include a flange or flanges 58. The flanges 58 can be used to connect the damper 38 to the lid support 24. For example, the flanges 58 can include apertures which can align with apertures on the members 52, such that fasteners 54 are able to be placed through the apertures on both the flanges 58 and members 52, and secure the damper 38 to the lid support 24. This type of mounting arrangement can provide further benefits stemming from the symmetry. For example, as noted above, the forces created during dampening can be large. Thus, a symmetric arrangement of flanges, and/or other mounts, can help maintain desired alignment of components.

[0044] The damper 38 can optionally further comprise a biasing element 60. The biasing element 60 can comprise a spring, elastic membrane, or other type of biasing device. As illustrated in FIG. 6, the biasing element 60 can be nested within a lower portion of the damper 38, and can be connected with and/or in contact with an end of the housing 56.

[0045] The biasing element 60 can also be connected with and/or in contact with a piston support 62. The piston support 62 can comprise an element configured to slide within the housing 56, and can include a groove, recess, or other area for receiving a seal 64.

[0046] With continued reference to FIGS. 5 and 6, the damper 38 can comprise a piston 66, which can extend along a length of the interior of the housing 56. One end of the piston 66 can be nested inside of or connected to a portion of the piston support 62, such that as the piston 66 is moved towards one end of the housing 56, the piston support 62 is also moved towards the same end of the housing 56. A portion of the piston 66 can extend outside of the housing 56, as illustrated in FIG. 6, through a piston guide 68.

[0047] The piston guide 68 can extend through a receiving area 70 on the lid support 24. The receiving area 70 can include an aperture 72. One end of the piston 66 can thus extend through both the piston guide 68 and aperture 72.

[0048] With continued reference to FIG. 6, in some embodiments the seal 64 can comprise a lip seal. The seal 64 can be comprised at least in part of flexible, resilient material, and can be configured to operate similarly to a check valve. Thus, the seal 64 can have any configuration that can provide a similar function.

[0049] The seal 64 can be generally annular in shape, having an inner wall 74 and an outer wall 76 connected by a top wall 78. The outer wall 76 can include an upper portion 80 that extends generally parallel to an inner wall of the housing 56, and a projecting portion 82 that is biased to extend radially outwardly relative to the upper portion 80. As such, the outer diameter of the seal 64 defined by the upper portion 80 is slightly smaller than the outer diameter of the seal 64 defined by the projecting portion 82. Additionally, the ramped configuration of the projecting portion 82 (when in a relaxed state) relative to the upper portion 80 helps to achieve the check valve type functionality of the seal 64.

[0050] With continued reference to FIG. 6, in some embodiments the piston 66 can be positioned such that its uppermost surface and tip is in a position in which a piston engaging mechanism 84 of the moveable lid 34 contacts the piston 66 prior to the moveable lid 34 reaching its fully closed position. For example, the piston engaging mechanism 84 can comprise a shoulder or extension off of a portion of the moveable lid 34, and can further comprise a surface 86 configured to contact the end of the piston 66. When the piston 66 is contacted by the piston engaging mechanism 84, the piston engaging mechanism 84 can force the piston 66 down into the housing 56. An air resistance and/or biasing resistance of the damper 38 can slow the closing movement of the moveable lid 34 and prevent the moveable lid 34 from impacting the body portion 22 in an undesired manner as the moveable lid 34 moves toward its closed position. In some embodiments the portion of the piston in contact with the piston engaging mechanism 84, and/or the piston engaging mechanism 84 itself, can further comprise a sound-deadening material.

[0051] In some embodiments, as the piston engaging mechanism 84 pushes the piston 66 down into the housing 56, the relative pressure between the atmosphere acting on the

bottom of the piston support 62, and the air trapped between the top of the piston support 62 and the top of the housing 56 can oppose the immediate downward motion of the piston 66 as the piston 66 begins to move downwardly, and thus oppose the downward motion of the moveable lid 34.

[0052] In some embodiments, the damper 38 can be configured to provide less resistance to the upward movement of the piston 66 within the housing 56 but provide greater resistance against the downward movement of the piston 66 within the housing 56. This can be accomplished in any known manner.

[0053] For example, with continued reference to FIG. 6, as the piston 66 and piston support 62 move upwardly within the housing 56 in the direction of arrow U, air can flow downwardly along the inner walls of the housing 56, past the projecting portion 82 of the seal 64. Due to the ramped shape of the projecting portion 82, the pressure generated within the upper portion of the housing 56 above the piston support 62 helps deflect the projecting portion 82 radially inwardly, thereby allowing the air to pass thereby without generating a larger resistance.

[0054] However, when the piston 66 and piston support 62 move downwardly within the housing 56, the air pressure in the space above the piston support 62 drops relative to the pressure of the atmosphere, thereby causing the projecting portion 82 to further expand against the inner walls of the housing 56. This generates additional resistance to the flow of air into the space above the piston support 62. As such, the seal 64 generates more resistance to the downward movement of the piston 66 than against the upward movement of the piston 66.

[0055] In some embodiments, the seal 64 can be lubricated with graphite powder. Such lubrication with graphite powder and the construction of dampers, which can be applied to the present dampers 38, are disclosed in U.S. Pat. Nos. 6,513,811 and 6,726,219, the entire contents of both of which, including the specific portions including the descriptions of damper design and lubrication with graphite powder, are hereby incorporated by reference. Additionally, the size of the damper 38 can be chosen by the designer to provide the desired functionality and performance.

[0056] For example, the height of the housing 56, which can determine the length of the maximum vertical movement of the piston 66 within the housing 56, can be chosen to accommodate the maximum desired vertical displacement of the piston support 62 within the housing 56. Additionally, the diameter of the housing 56 and the type of seal 64 used can affect the resistance generated during the downward movement of the piston 66. Thus, these dimensions can be chosen to provide the desired dampening characteristics.

[0057] Further advantages can also be achieved where the size of the housing 56 and the position at which the housing 56 is mounted within the assembly 20 can be adjusted to provide desired characteristics of the motion of the moveable lid 34 during its closing movement. For example, if the housing 56 is mounted in a position where the piston support 62 is spaced excessively far from the top of the housing 56 when the piston 66 is at its maximum vertical position, the moveable lid 34 can initially move too quickly from its fully opened position toward its closed position. Such an initial quick movement can cause the moveable lid 34 to bounce during its downward movement.

[0058] However, if the mounting position of the housing 56 is adjusted, or the damper 38 in general is adjusted, so that the

piston support 62 is closely spaced relative to the top of the housing 56 when the piston 66 is at its maximum upper position, the damper 38 can provide additional dampening, at least initially, thereby providing a slower, more aesthetically pleasing motion.

[0059] For example, by adjusting the position of the housing 56 and/or configuration of the damper 38 to space the piston support 62 near the top of the housing 56 when the piston 66 is at its maximum position, the moveable lid 34 can begin to move very slowly initially, and slowly accelerate to an acceptably slow closing speed, such that the moveable lid 34 does not make an excessive loud noise when it finally comes to rest. In some embodiments, the spacing can be equal to or less than about 10% of the total movement of the piston 66. The initial movement of the piston 66 can be further slowed at a spacing of about 5% or less of the total movement of the piston 66. Finally, mounting the housing 56 and/or adjusting the damper 38 such that the spacing is about 4% or less of the total movement of the piston 66 can provide further slowing, and thus achieve a more aesthetically pleasing movement.

[0060] A designer can choose the appropriate housing, piston, and seal combination to achieve the desired closing speed. Thus, in some embodiments, at least one of the moveable lid 34, housing 56, piston 66, piston support 62, and seal 64 can be configured to achieve the desired closing speed. In some embodiments, for example, but without limitation, the above parameters can be chosen to achieve a closing speed of the lid of about 5 seconds from the moment the center of gravity of a moveable lid 34 passes over a pivot point and gravity begins to pull the moveable lid 34 closed.

[0061] With continued reference to FIGS. 5 and 6, the biasing element 60 can additionally, or alternatively, provide dampening support in the damper 38. For example, as the piston 66 and piston support 62 are moved in a downward direction by the force of the piston engagement mechanism 84 pressing on the piston 66, the biasing element 60 can apply pressure to the piston support 62. This pressure can act to resist quick downward movements of the piston support 62 and piston 66 within the housing 56, and dampen the movement of the moveable lid 34 as the moveable lid 34 moves toward a closed position. In some embodiments, the damper 38 does not include a biasing element 60, and only includes the seal 64. In some embodiments the damper does not include the seal 64, and only includes the biasing element 60. In some embodiments both elements are included to provide damping effect. In some embodiments, the biasing element 60 only acts to push the piston 66 towards a pre-determined position, and/or highest vertical position, and the seal 64 acts to dampen the moveable lid 34 movement.

[0062] With continued reference to FIGS. 5 and 6, the biasing element 60 can be a coiled spring. The spring can be pre-tensioned, such that when the moveable lid 34 is in a fully opened position, the biasing element 60 is pushing upwardly against the piston support 62, and pushing the top of the piston 66 through the piston guide 68 so that the top of the piston 66 extends well past the wall 88 of the lid support member 32. In some embodiments, the fully opened position comprises the moveable lid 34 being at about a 90 degree angle relative to the base portion 26. In some embodiments, the fully opened position comprises any position in which the moveable lid 34 does not contact the piston engaging mechanism 84.

[0063] When the moveable lid 34 is moved down towards a closed position (e.g. when gravity is pulling the moveable lid 34 down), the surface 86 of the piston engaging mechanism 84 can contact the top of the piston 66 and drive the piston 66 down through the piston guide 68 and further into the housing 56. As the piston 66, and piston support 62, are moved further into the housing 56, the biasing element 60 can resist the motion of the piston support 62, such that the speed of the moveable lid 34 as it is closing is reduced prior to the moveable lid 34 reaching a fully closed position. In some embodiments, the fully closed position can be considered the position achieved when the moveable lid 34 contacts a portion of the lid support member 32. In some embodiments, the fully closed position can correspond to when the moveable lid 34 is substantially closed, but not contacting the lid support member 32.

[0064] With continued reference to FIGS. 5 and 6, the housing 56 described above can be made from a material commercially available under the trade name Acetal Delrin with 10% Teflon added. The piston 66 can also be made from the material known as Acetal Delrin. Further, the seal 62 can be made from graphite impregnated nitrile. Other materials can also be used.

[0065] The assembly 20 can comprise additional or alternative damping mechanisms apart from the damper 38 described above. For example, the lid portion 24 can be configured to utilize the air flow generated during a closing movement of a lid 34 to further dampen the closing movement.

[0066] For example, in some embodiments, at least one of the moveable lids 34 can have a concave configuration and profile, as illustrated for example in FIGS. 1 and 2. This concave profile can generate or enhance a scooping action of the lid which can help, at least temporarily, confine within the assembly 20 when the lid 34 is moved from an open position to a closed position. For example, a moveable lid 34 formed in a curved, concave profile can act like a cup, trapping air underneath the moveable lid 34 as the moveable lid 34 moved downward. This trapping of air underneath the moveable lid 34 and/or inside the body portion 22 can create air resistance to downward movement of the moveable lid 34 from the open position to the closed position. Thus, the concave nature of the moveable lid 34 can act to dampen movement of the moveable lid 34 in at least one direction.

[0067] Additionally or alternatively, and with reference to FIGS. 5 and 6, the moveable lid 34 can comprise a top edge 90, and the lid support member 32 can comprise a top edge 92. An external peripheral wall 94 adjacent the top edge 90 can extend down towards the damper 38. The external peripheral wall 94 can extend around at least a portion of the entire periphery of the moveable lid 34. In some embodiments, the wall 94 can include cutouts, notches, or gaps if desired.

[0068] The lid support member 32 can include an internal peripheral wall 96 adjacent the top edge 92, the internal peripheral wall 96 extending around at least a portion of the periphery of the lid support member 32. The internal peripheral wall 96 can have a shape or configuration complementary to that of the peripheral wall 94. In some embodiments, the peripheral wall 96 can include cutouts, notches, or gaps if desired. As described above, the lid support member 32 can further include a lower wall 88. The lower wall 88 and peripheral wall 96 together can form a shoulder, with the peripheral wall 94 sitting or nesting within the shoulder when the moveable lid 34 is in a closed position.

[0069] In some embodiments, the fit and/or tight spacing between the peripheral wall 94 and the shoulder defined by walls 88 and 96 can form a generally air resistant seal between the lid support member 32 and moveable lid 34. However, it is not necessary for the above-described fit to form an air resistant seal. The contact and or close spacing between the peripheral walls 94 and 96 can be sufficiently continuous to resist the flow of air therebetween to achieve the desired dampening effect.

[0070] For example, as the moveable lid 34 moves from an open position to a closed position, the peripheral wall 94 of the moveable lid 34 can move into close proximity to the wall 96 of the lid support member 32, and a slight compression of the air within the containers 30 and/or body portion 22 can be generated. When the moveable lid 34 is in its open position, the air within the body portion 22, existing within and above any trash that may be contained in the containers 30 or liners inside the containers 30, is at atmospheric pressure.

[0071] As the moveable lid 34 closes, a positive pressure can be created in the assembly 20, and air underneath the moveable lid 34, including but not limited to air near the wall 88 and air within the body portion 22, is urged out of the assembly 20 in order for the moveable lid 34 to close completely. However, because of the tight fit between the peripheral wall 94 and the peripheral wall 96, some or all of the air can be retained, briefly retained, or temporarily trapped, thus providing at least some air resistance to downward movement of the moveable lid 34. As gravity, or any other force, continues to push the moveable lid 34 toward a closed position, this “trapped” air can leak out through the small space between the peripheral wall 94 and peripheral wall 96, or through other apertures or openings in the assembly 20. The configuration of the peripheral walls 94 and 96 can thus act as an air guide, guiding the trapped air slowly out of the assembly while dampening the movement of the moveable lid 34.

[0072] The clearance between the walls 94 and 96 can be altered. For example, the configuration and/or size of the walls 94 and 96 can vary, such that the amount of time the walls spend moving past one another, or in close proximity to one another, can change. In some embodiments, an increased height of one or both walls can increase the time the moveable lid 34 is dampened, thus slowing down the movement of the moveable lid 34 to an even greater degree, or for a greater amount of time. Changing the shape of the walls 94 and 96, or introducing other components or elements along the periphery of the moveable lid 34 and/or lid support member 32, can further alter the dampening effect.

[0073] By providing additional dampening, in addition to the dampening provided by the damper 38, can provide further advantages. For example, because the air “trapping” technique noted above, begins to act just as the lid nears the fully closed position. This is also the point at which the torque created by the weight of the lids 34, pivoting the lids 34 toward their closed position, is the greatest. This is because as the lids 34 move from their fully opened position toward their open position, the centers of gravity of the lids 34 move from points nearly directly above the associated hinges, outwardly. As the lids 34 reach a horizontal position, their respective centers of gravity are at their maximum horizontal spacing from the axes of the hinges. As such, the greatest torques generated by the weights of the lids 34 are generated as the lids 34 reach their fully closed positions. Thus, by providing additional dampening as the lid nears its fully closed position

helps compensate for this additional torque. Further, modifying the dampers 38 to provide quickly increasing damping forces can be difficult.

[0074] With reference to FIGS. 7-10, another embodiment of a receptacle assembly 120 is illustrated. The assembly 120 can be similar to the assembly 20. Therefore, similar components of the assembly 120 are referenced by the same reference numeral as the corresponding components in the assembly 20.

[0075] The assembly 120 can comprise a lid portion 24, an upper body portion 128, and a base portion 126. The lid portion 24 can comprise a lid support member 32, moveable lids 34, and handles 36, as described above. In some embodiments, the lid portion 24 can rest on or be supported by the upper body portion 128.

[0076] The upper body portion 128 can comprise a single outer shell 31, which can receive the containers 30 as illustrated in FIG. 10. In some embodiments, outer surfaces of outer shell 31 can be substantially flush with outer surfaces of the lid support member 32 of the lid portion 24.

[0077] With reference to FIG. 8, the body 128 can further comprise at least one gripping feature 98. For example, the gripping feature 98 can comprise a recessed surface or surfaces along the outer shell 31. The gripping feature 98 can create an area large enough to accommodate an operator's hand, such that the operator can grip the body 128 along the gripping feature 98 and lift the entire assembly 120 off of the ground to be transported from one location to another.

[0078] With reference to FIGS. 8 and 9, the base portion 126 can comprise at least one anti-sliding mechanism 50 along a bottom surface. As described above, the anti-sliding mechanisms 50 can inhibit unwanted movement of the assembly 120.

[0079] With reference to FIGS. 1 and 10, in some embodiments the upper body portion 28, 128 or lid portion 24 can include an upper support member or members. For example, and with reference to FIG. 10, in some embodiments the upper support member can comprise at least a portion of the lid support member 32. The upper support member or members can be made monolithically with the shell or shells 30 or lid portion 24, or can be made from separate components attached to the shell or shells 30 or lid portion 24.

[0080] The upper support member, such as for example lid support member 32, can be configured to support a container 30 within the interior cavity or cavities defined by the shell or shells 31. In some embodiments, the upper support member can include a shoulder configured to support an outwardly extending lip 102 of the container 30. As such, the liner or containers 30 can hang within the shell or shells 31 from the upper support member. However, in other configurations, the liner or containers 30 can rest upon an interior surface of the upper body portion 28, 128, lid portion 24, or the base 26, 126. In such a configuration, the upper support member, while it does not support the weight of the liner or containers 30, can provide for alignment of the liner or containers 30 within the body of the assembly 20. In some embodiments, the container or containers 30 can further comprise a bag retainer 104. The bag retainer 104 can be used to securely hold a plastic, or other type material, bag within the container 30. In some embodiments, the bag retainer 104 can comprise an elongate slot with a plurality of fingers nested together in a side-by-side relationship. In other embodiments, the bag retainer 104 can comprise openings, such as a circle or oval.

[0081] With reference to FIG. 10, when a container 30 is resting within the shell or shells 31, the outwardly extending lip 102 can extend adjacent the finger-grip regions 48 such that the finger-grip regions 48 provide an opening for an operator to insert a finger or hand, and lift the container 30 out of the shell 31.

[0082] As with the embodiment illustrated in FIGS. 1-6, the assembly 120 can comprise at least one damper. For example, the damper can comprise a damper 38 such as illustrated in FIGS. 4-6. The damper can comprise a piston 66, shown in FIG. 10, extending through a piston guide 68. The moveable lid 34 can comprise a piston engaging mechanism 84, which can move towards and contact the piston 66 when the moveable lid 34 is moved toward a closed position.

[0083] Additionally, the lid support member 32 can comprise a top edge 92. The lid support member 32 can include an internal peripheral wall 96 adjacent the top edge 92, the internal peripheral wall 96 extending around at least a portion of the entire periphery of the lid support member 32. The internal peripheral wall 96 can have a shape or configuration complementary to that of a peripheral wall 94 (not shown) on the moveable lid 34. The lid support member 32 can further include a lower wall 88. As described above, the lower wall 88 and peripheral wall 96 can together form a shoulder, with the peripheral wall 94 of the moveable lid 34 sitting or resting tightly within the shoulder when the moveable lid 34 is in a closed position.

[0084] As described above, the fit and/or tight spacing between the peripheral wall 94 of the moveable lid 34 and the shoulder defined by walls 88 and 96 can form a generally air resistant seal between the lid support member 32 and moveable lid 34. However, it is not necessary for the above-described fit to form an air resistant seal. The contact and or close spacing between the peripheral walls 94 and 96 can be sufficiently continuous to sufficiently resist the flow of air therebetween to achieve the desired dampening effect.

[0085] With reference to FIGS. 1 and 10, in some embodiments the moveable lid or lids 34 can be biased toward the closed and resting positions, respectively, by way of any known device or configuration. For example, the moveable lid 34 can open less than 90 degrees with respect to the base portion 26 and, thus, the weight of the moveable lid 34 can be sufficient to move the moveable lid 34 toward the closed position when no force other than gravity is acting on the moveable lid 34. Optionally, springs can be added to the assembly 20, in any known configuration, to bias the moveable lid 34 toward the closed position. In some embodiments, once the moveable lids 34 are in an open position, they can remain in an open position until an external force, such as for example an operator's hand, moves the moveable lids 34 toward a closed position. Initial movement of the moveable lids 34 toward the closed position can cause the centers of gravity of the moveable lids 34 to pass over a pivot point, thus allowing gravity alone to move the moveable lids 34 the rest of the way toward a final closed position.

[0086] In some embodiments, the moveable lid or lids 34 can be moved by use of a pedal actuating mechanism or mechanisms. For example, the receptacle assembly 20 or 120 can include one or more pedal actuating mechanisms as described in U.S. Patent Publication No. 2006/0196874, U.S. Pat. No. 7,656,109, U.S. Patent Publication No. 2007/0182551, U.S. patent application Ser. No. 12/399,828, U.S. Patent Publication No. 2006/0226149, and U.S. Patent Pub-

lication No. 2008/0237234, the entirety of each of which is hereby incorporated by reference.

[0087] Although these inventions have been disclosed in the context of certain preferred embodiments and examples, it will be understood by those skilled in the art that the present inventions extend beyond the specifically disclosed embodiments to other alternative embodiments and/or uses of the inventions and obvious modifications and equivalents thereof. In addition, while several variations of the inventions have been shown and described in detail, other modifications, which are within the scope of these inventions, will be readily apparent to those of skill in the art based upon this disclosure. It is also contemplated that various combinations or sub-combinations of the specific features and aspects of the embodiments can be made and still fall within the scope of the inventions. It should be understood that various features and aspects of the disclosed embodiments can be combined with or substituted for one another in order to form varying modes of the disclosed inventions. Thus, it is intended that the scope of at least some of the present inventions herein disclosed should not be limited by the particular disclosed embodiments described above.

What is claimed is:

1. A trashcan comprising:
 - a body defining an interior space, the body comprising a base portion and an upper body portion;
 - a lid portion supported by the upper body portion, the lid portion comprising a lid support having an interior peripheral wall and two lids moveably mounted to the lid support so as to be independently moveable between open and closed positions, at least one of the lids having a generally concave profile;
 - a first motion damper connected to the lid portion, and a second motion damper connected to the lid portion, wherein the first and second motion dampers are configured to dampen a movement of at least one of the two lids from the open position to the closed position;
 wherein at least one of the two lids comprises an exterior peripheral wall, the interior peripheral wall of the lid support and the exterior peripheral wall of the at least one lid being juxtaposed relative one another when the at least one lid is in the closed position so as to trap air within the lid portion and dampen lid movement when the at least one lid is moving from the open position to the closed position.
2. A trashcan comprising:
 - a body defining an interior space, the body comprising a base portion and an upper body portion;
 - a lid portion supported by the upper body portion, the lid portion comprising a lid support and at least one lid mounted to the lid support, the at least one lid being independently moveable between open and closed positions;
 - at least one motion damper comprising a housing secured to the lid support and further comprising a moveable piston at least partially housed within the housing;
 - wherein the at least one lid comprises a surface for contacting and driving the moveable piston as the lid is moved towards the closed position.
3. The trashcan of claim 2, wherein the housing is rigidly fastened to a lower wall of the lid support.
4. The trashcan of claim 2, wherein the at least one motion damper comprises first and second motion dampers, and wherein the at least one lid comprises first and second lids.

5. The trashcan of claim 2, wherein the at least one motion damper is configured to provide less resistance to an upward movement of the piston within the housing but provide greater resistance against a downward movement of the piston within the housing.

6. The trashcan of claim 2, wherein the at least one lid is configured to move towards the closed position for a first predetermined distance before engaging the moveable piston.

7. The trashcan of claim 2, wherein the at least one motion damper comprises a piston support configured to support one end of the piston inside the housing, a biasing element engaged with the piston support, and a seal engaged with the piston support, the seal having a flexible body configured to facilitate movement of the piston support in one direction within the housing, but inhibit movement of the piston support in an opposite direction.

8. The trashcan of claim 7, wherein the seal comprises an upper portion and a flexible projecting portion that is biased to extend radially outwardly relative to the upper portion.

9. The trashcan of claim 7, wherein the piston has a predetermined range of linear movement within the housing, and wherein the piston support is closely spaced relative to a top of the housing when the piston is at a maximum upper position.

10. The trashcan of claim 9, wherein the distance between the piston support and the top of the housing is approximately less than 10% of the predetermined range of movement of the piston.

11. The trashcan of claim 7, wherein the housing comprises a piston guide surrounding the piston.

12. The trashcan of claim 2, wherein the at least one lid is a pedal-actuated lid.

13. A trashcan comprising:

- a body defining an interior space, the body comprising a base portion and an upper body portion;

- a lid portion supported by the upper body portion, the lid portion comprising at least one pivotable lid having a generally concave profile, the pivotable lid being independently moveable between open and closed positions such that the generally concave profile of the lid traps air within the interior space when the at least one lid moves from the open position to the closed position.

14. The trashcan of claim 13, wherein the generally concave profile gives the lid a curved surface configured to act like a cup, trapping air underneath the lid as the lid moves towards the closed position.

15. A trashcan comprising:

- a body defining an interior space, the body comprising a base portion and an upper body portion;

- a lid portion supported by the upper body portion, the lid portion comprising at least one lid moveably mounted to the lid portion so as to be independently moveable between open and closed positions, the lid portion comprising an interior peripheral wall, and the at least one lid comprising an exterior peripheral wall;

- wherein the interior and exterior peripheral walls are positioned adjacent one another when the at least one lid is in the closed position so as to trap air within the lid portion and dampen lid movement when the at least one lid is moving from the open position to the closed position.

16. The trashcan of claim 15, wherein the interior peripheral wall has a shape or configuration complementary to that

of the exterior peripheral wall, such that the interior peripheral wall is generally parallel to the exterior peripheral wall at any point along the lid portion.

17. The trashcan of claim **15**, wherein the interior peripheral wall comprises notches configured to allow air inside the trashcan container to escape as a lid moves towards a closed position.

18. The trashcan of claim **15**, wherein the lid portion further comprises a lower wall, the lower wall and interior peripheral wall forming a shoulder for receiving the exterior peripheral wall of the lid.

19. The trashcan of claim **15**, wherein the spacing between the exterior peripheral wall and the shoulder is configured to form a generally air-resistant seal between the lid and remainder of the lid portion.

20. A trashcan comprising:

a body defining an interior space, the body comprising a base portion and an upper body portion;

a lid portion supported by the upper body portion, the lid portion comprising at least one lid moveably mounted to the lid portion so as to be independently moveable between open and closed positions, the lid portion further comprising an air guide configured to guide air downwardly into the interior space as the at least one lid moves from the open position towards the closed position.

21. The trashcan of claim **20**, wherein the air guide comprises a curved surface on the lid.

* * * * *