



(19) **United States**

(12) **Patent Application Publication**  
**Gilliam et al.**

(10) **Pub. No.: US 2010/0200419 A1**

(43) **Pub. Date: Aug. 12, 2010**

(54) **LOW-VOLTAGE ALKALINE PRODUCTION FROM BRINES**

(22) Filed: **Feb. 10, 2010**

**Related U.S. Application Data**

(60) Provisional application No. 61/151,470, filed on Feb. 10, 2009.

(76) Inventors: **Ryan J. Gilliam**, Campbell, CA (US); **Valentin Decker**, Menlo Park, CA (US); **William Randall Seeker**, San Clemente, CA (US); **Bryan Boggs**, Campbell, CA (US); **Nikhil Jalani**, Campbell, CA (US); **Thomas A. Albrecht**, Mountain View, CA (US); **Matt Smith**, San Jose, CA (US)

**Publication Classification**

(51) **Int. Cl.**  
**C25B 1/02** (2006.01)  
**C25B 11/00** (2006.01)  
**C25B 15/00** (2006.01)  
(52) **U.S. Cl.** ..... **205/351; 204/280; 205/464**

(57) **ABSTRACT**

An alkaline production system comprising an electrochemistry unit comprising a hydrogen-oxidizing anode in communication with a cathode electrolyte; wherein the electrochemistry unit is operably connected to a carbon sequestration system configured to sequester carbon dioxide with the cathode electrolyte. In another embodiment, an electrochemistry unit comprising a hydrogen-oxidizing anode in communication with a cathode electrolyte; and a carbon sequestration system configured to sequester carbon dioxide with the cathode electrolyte; and methods thereof.

Correspondence Address:  
**Calera Corporation**  
**Eric Witt**  
**14600 Winchester Blvd.**  
**Los Gatos, CA 95032 (US)**

(21) Appl. No.: **12/703,605**

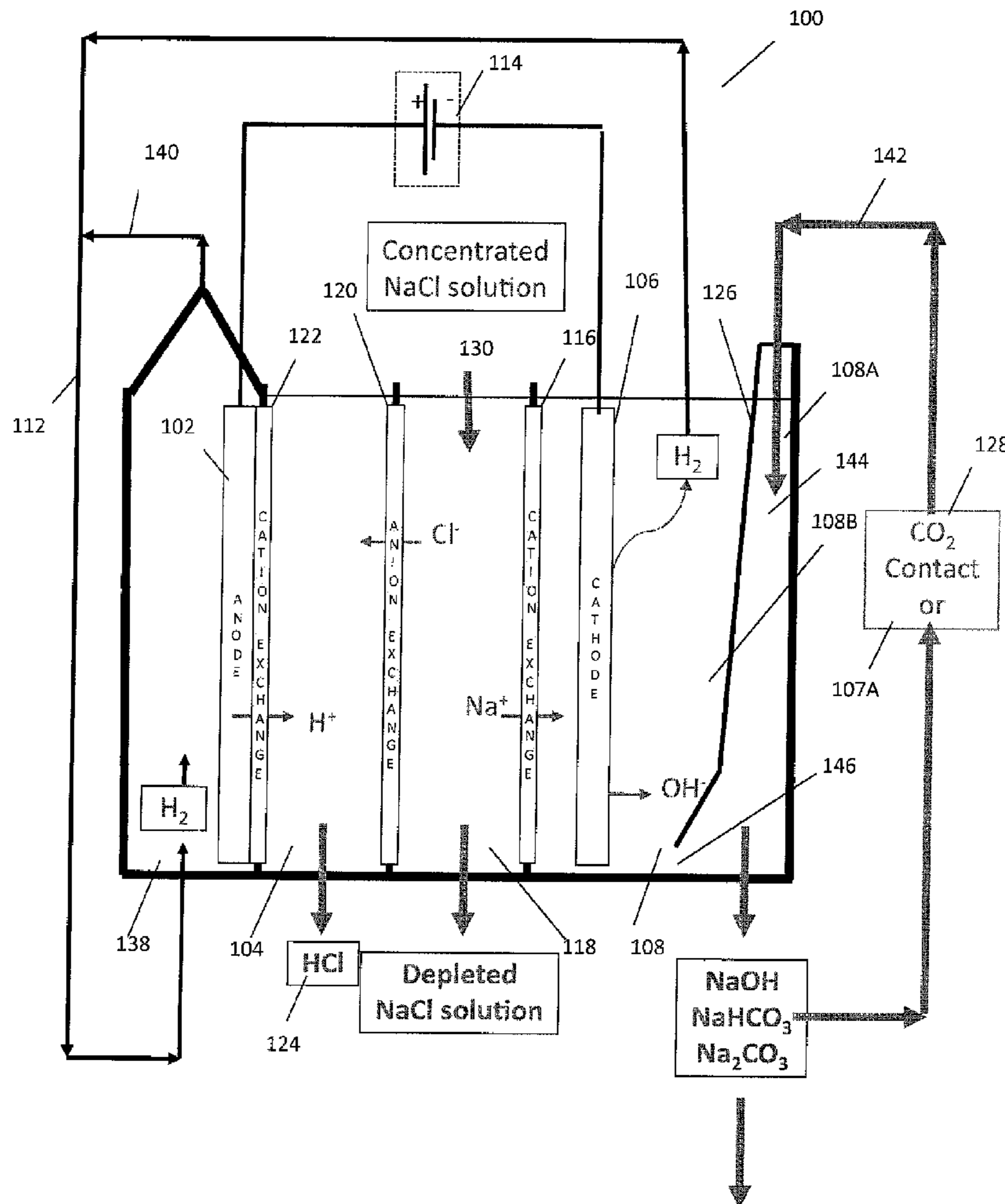

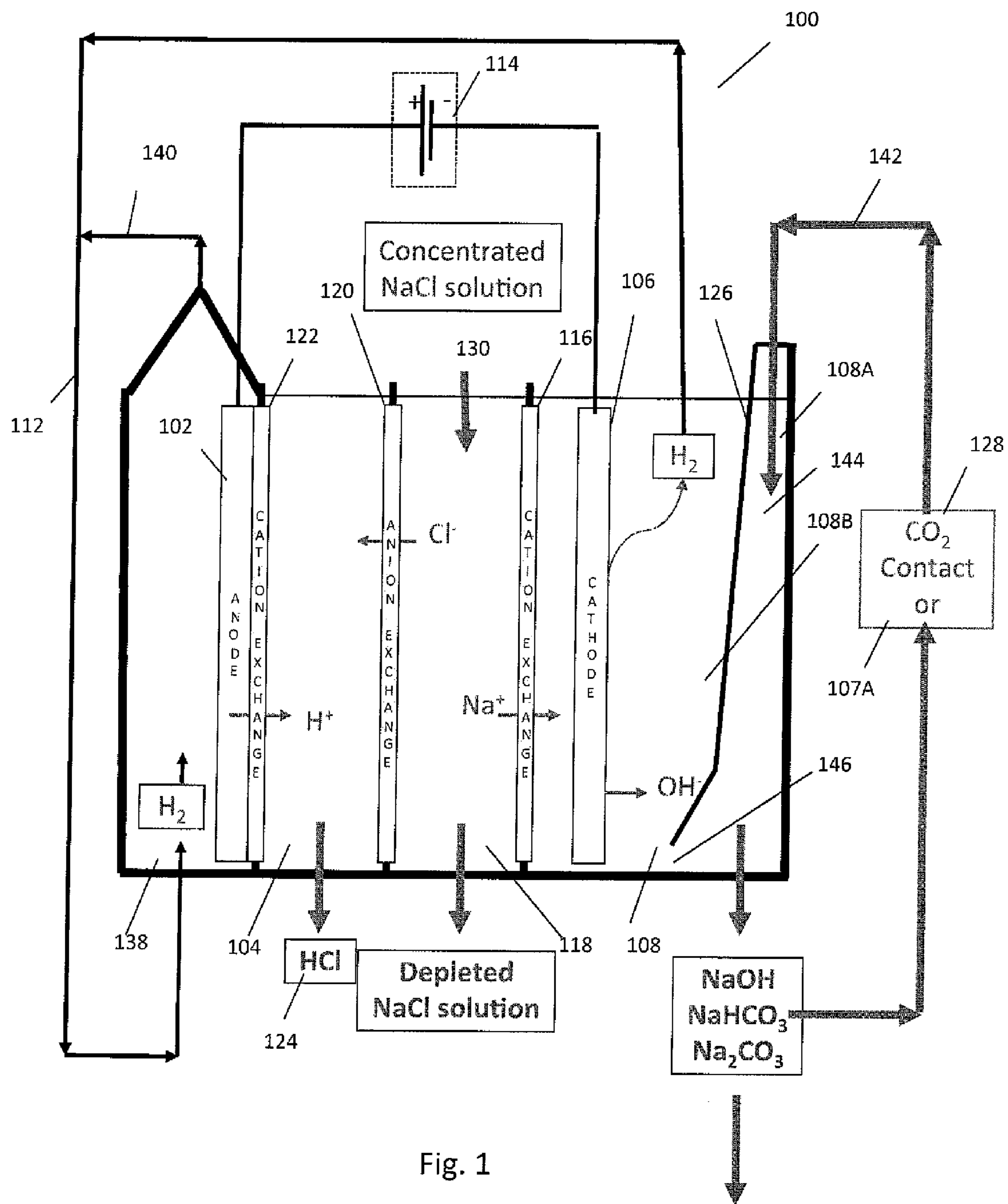

Fig. 1

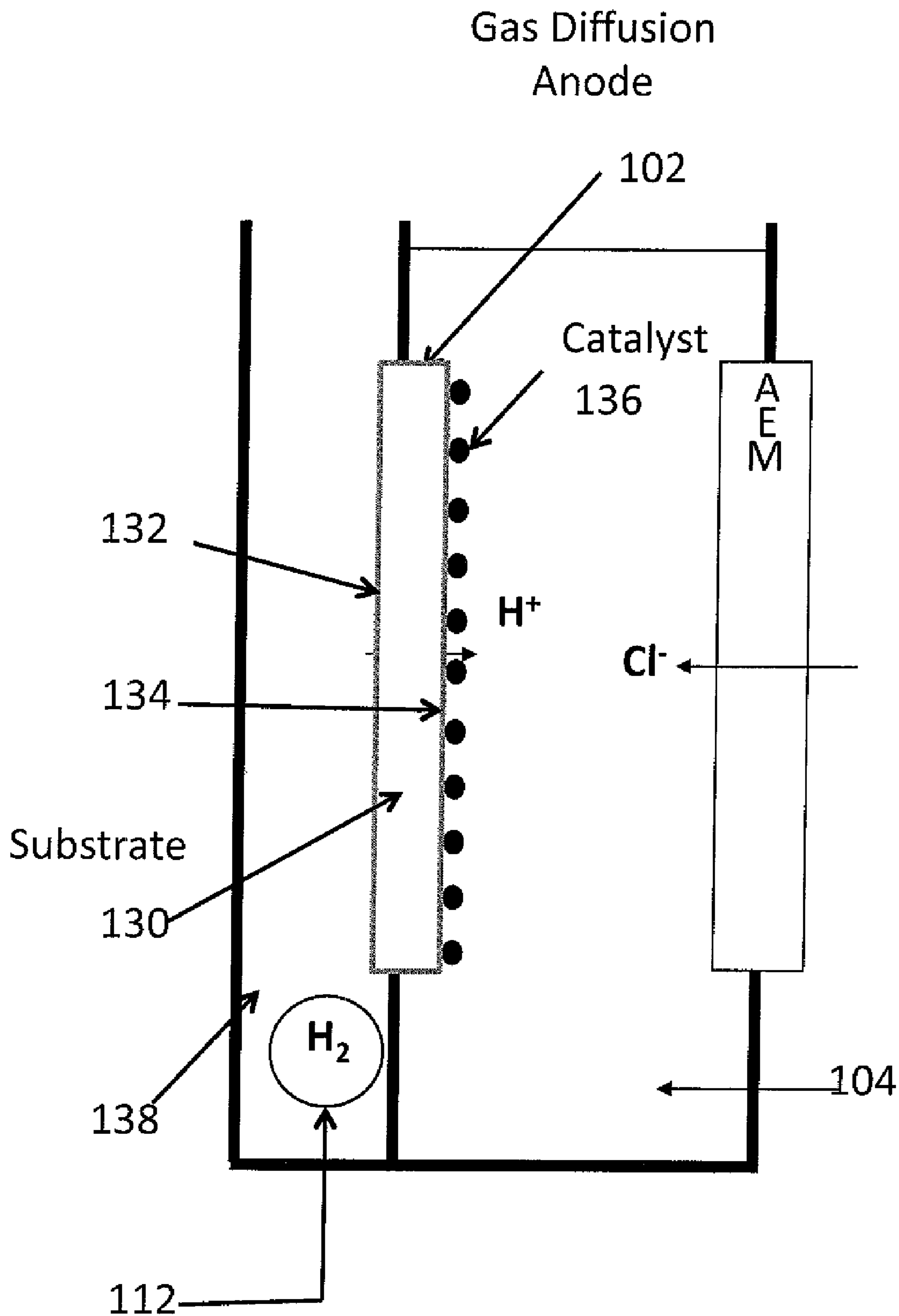

Fig. 2

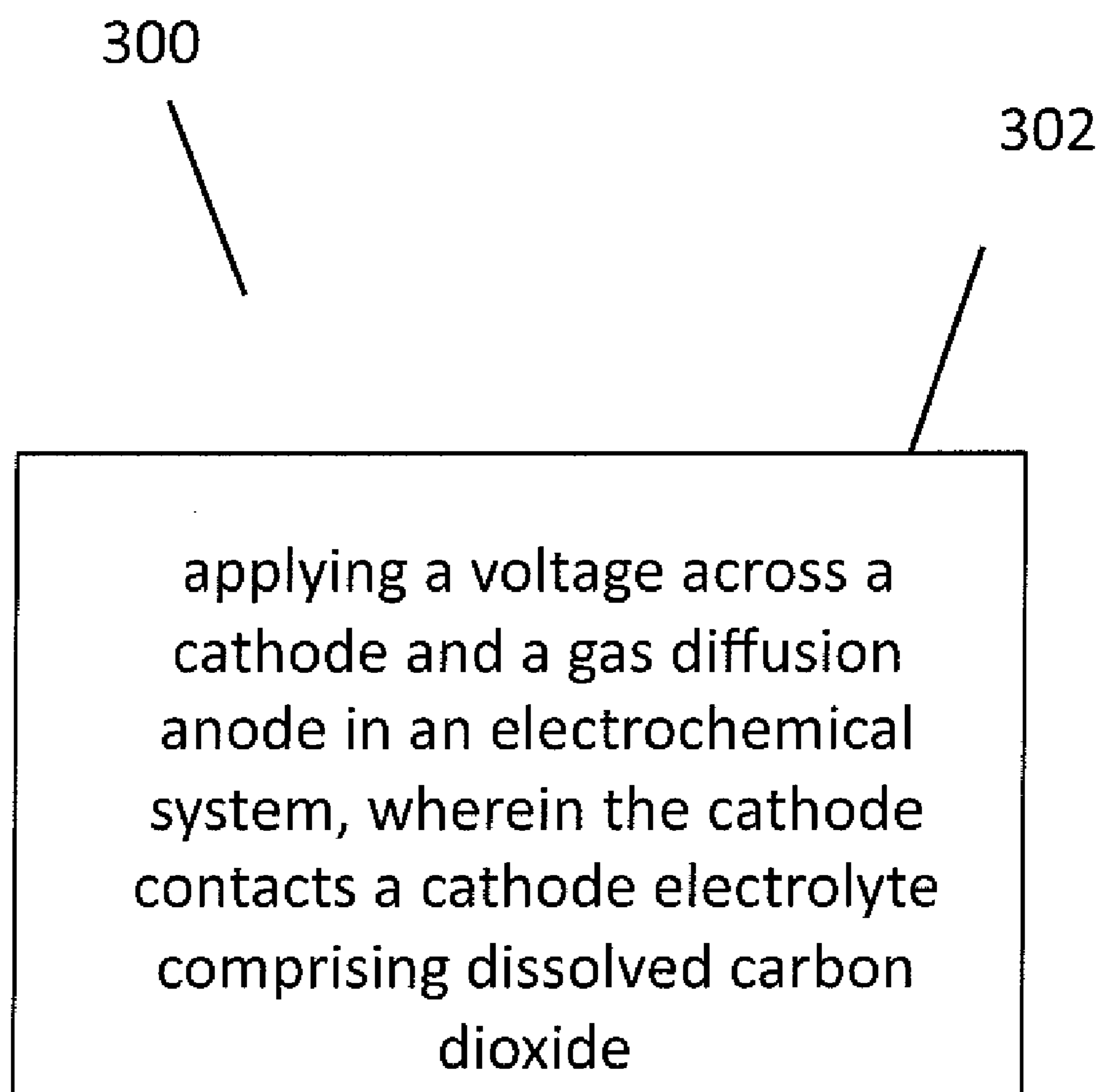

Fig. 3

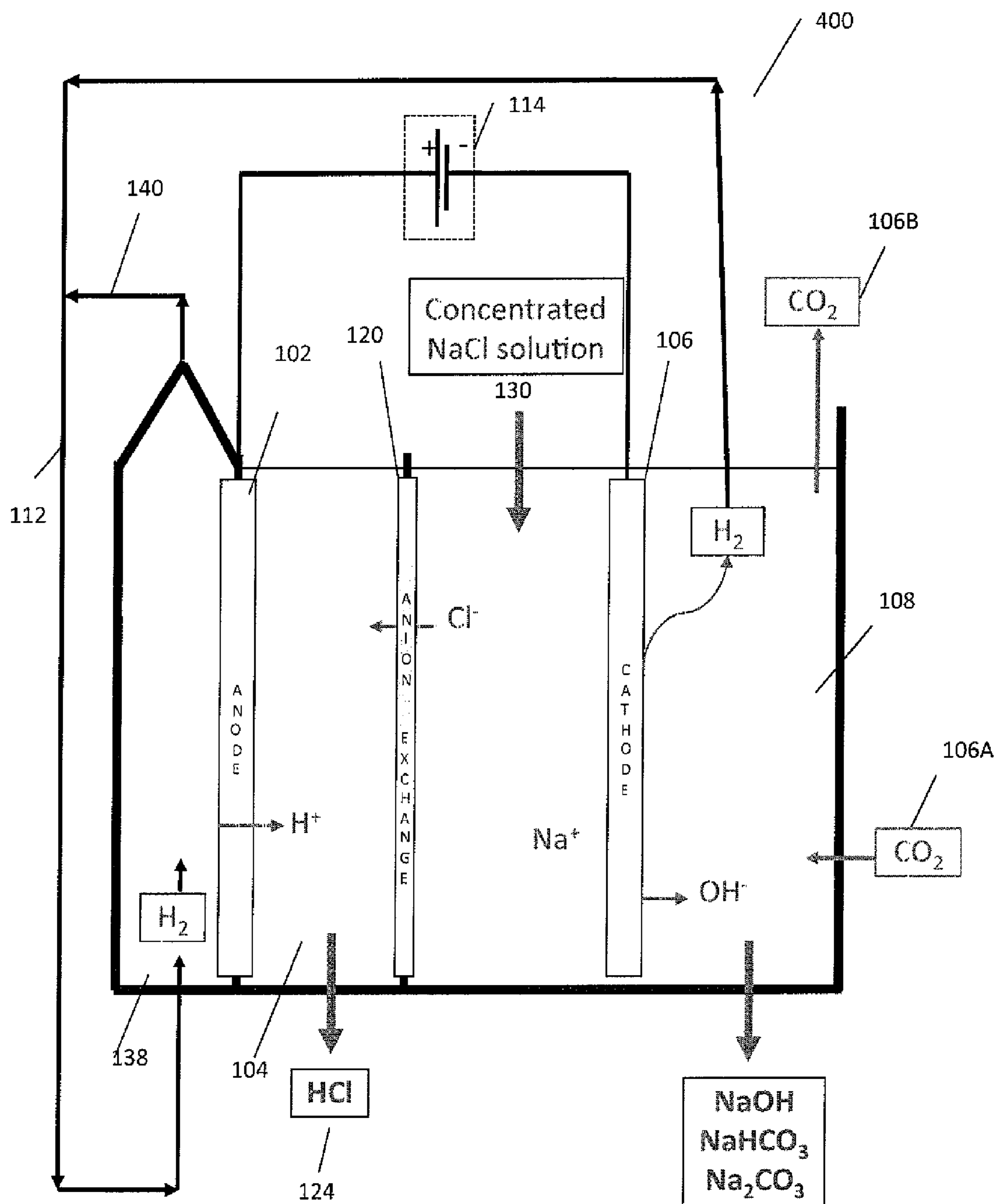
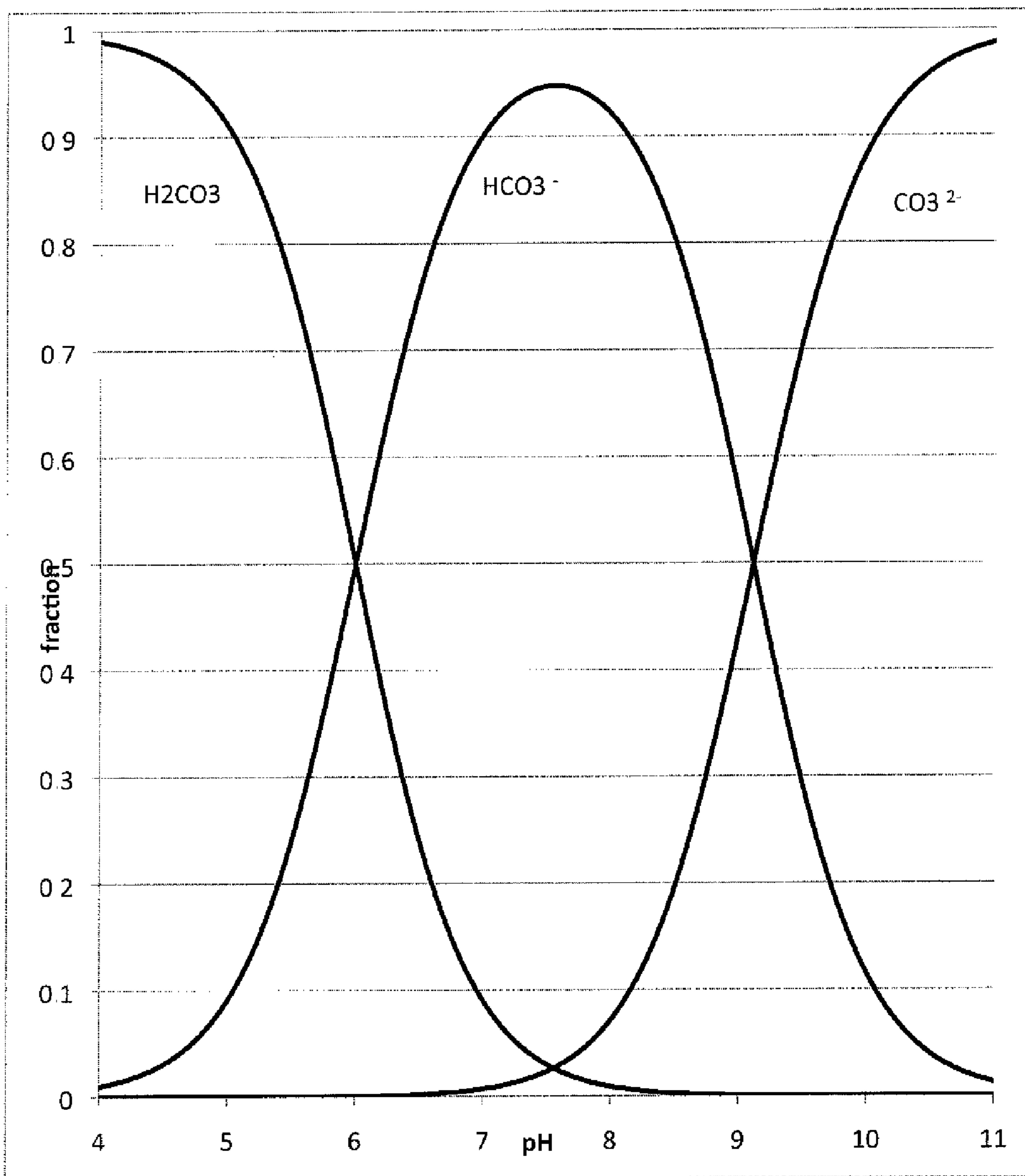

Fig. 4

Carbonate Composition w/pH and Temperature



Carbonate/Bicarbonate Speciation in H<sub>2</sub>O v. pH at 25 °C

Fig. 5

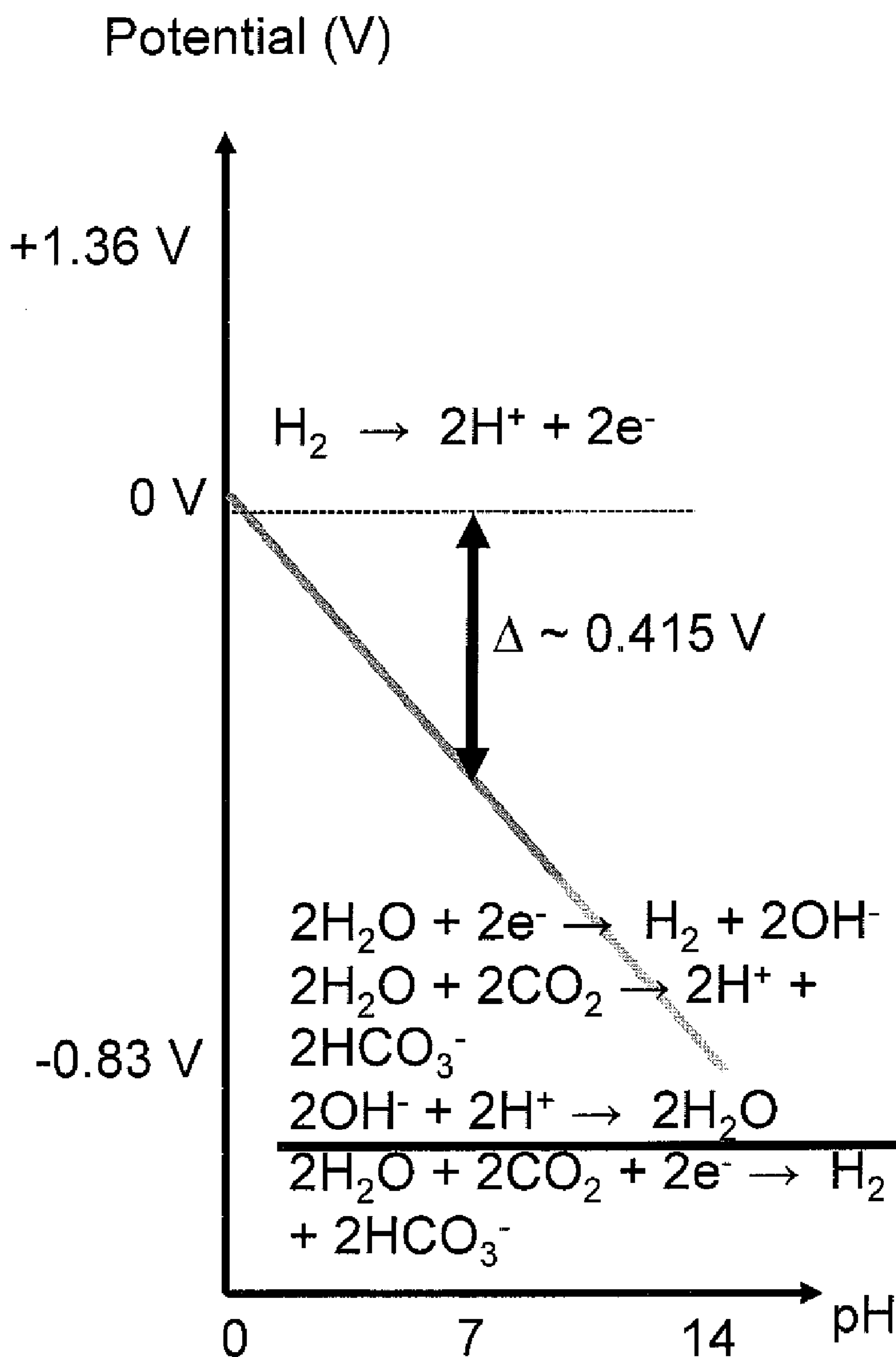

Fig. 6

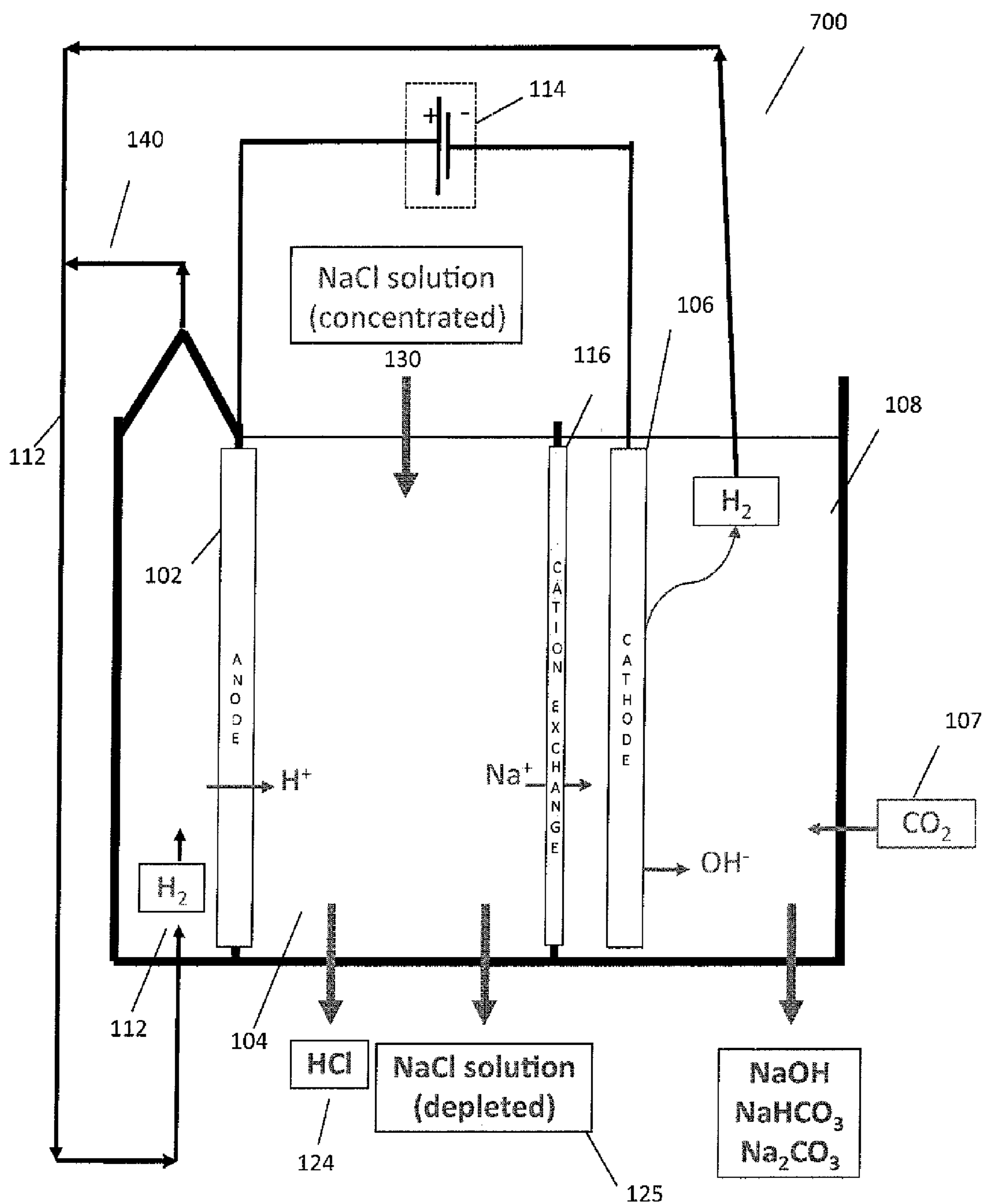

Fig. 7



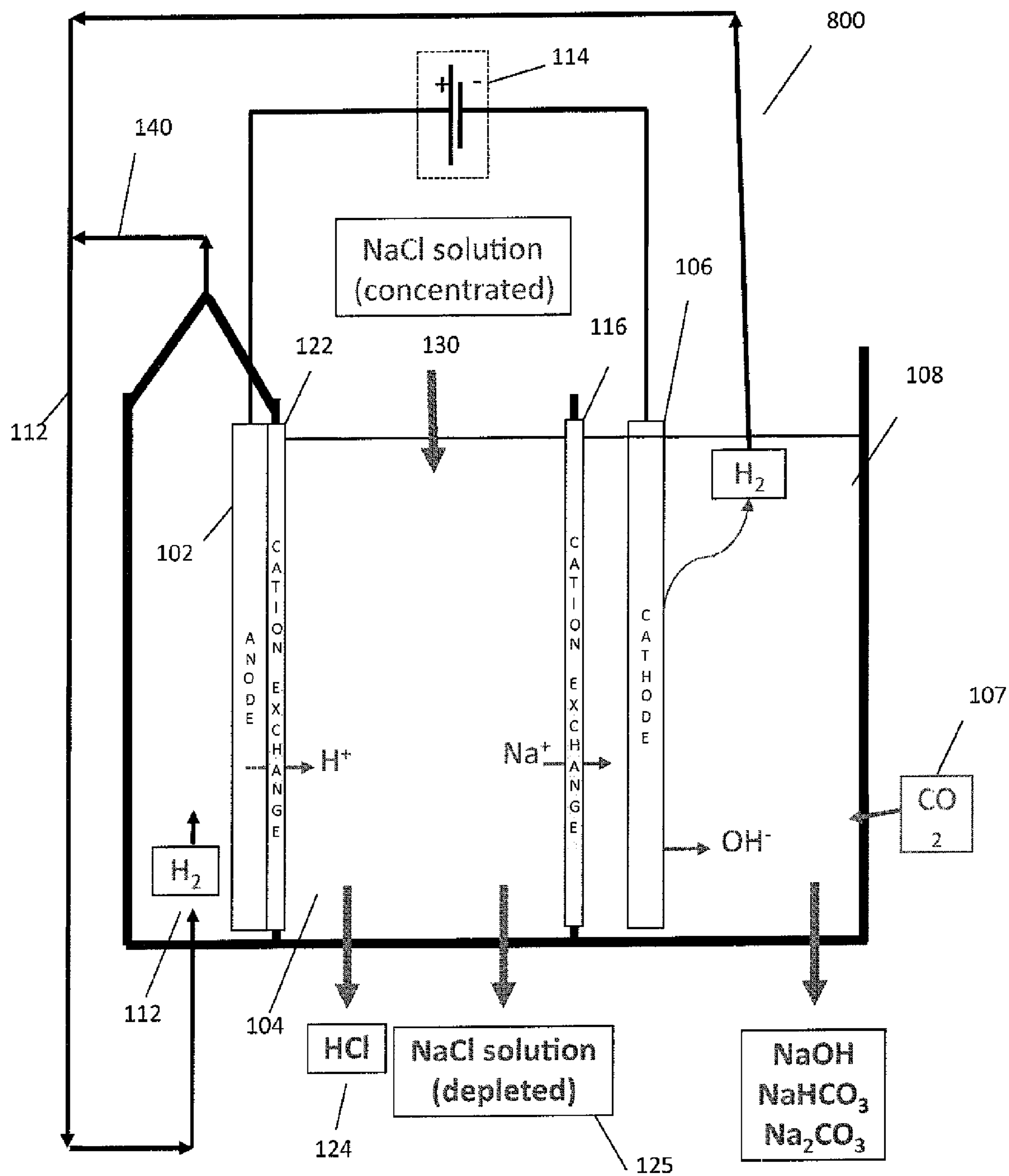

Fig. 8

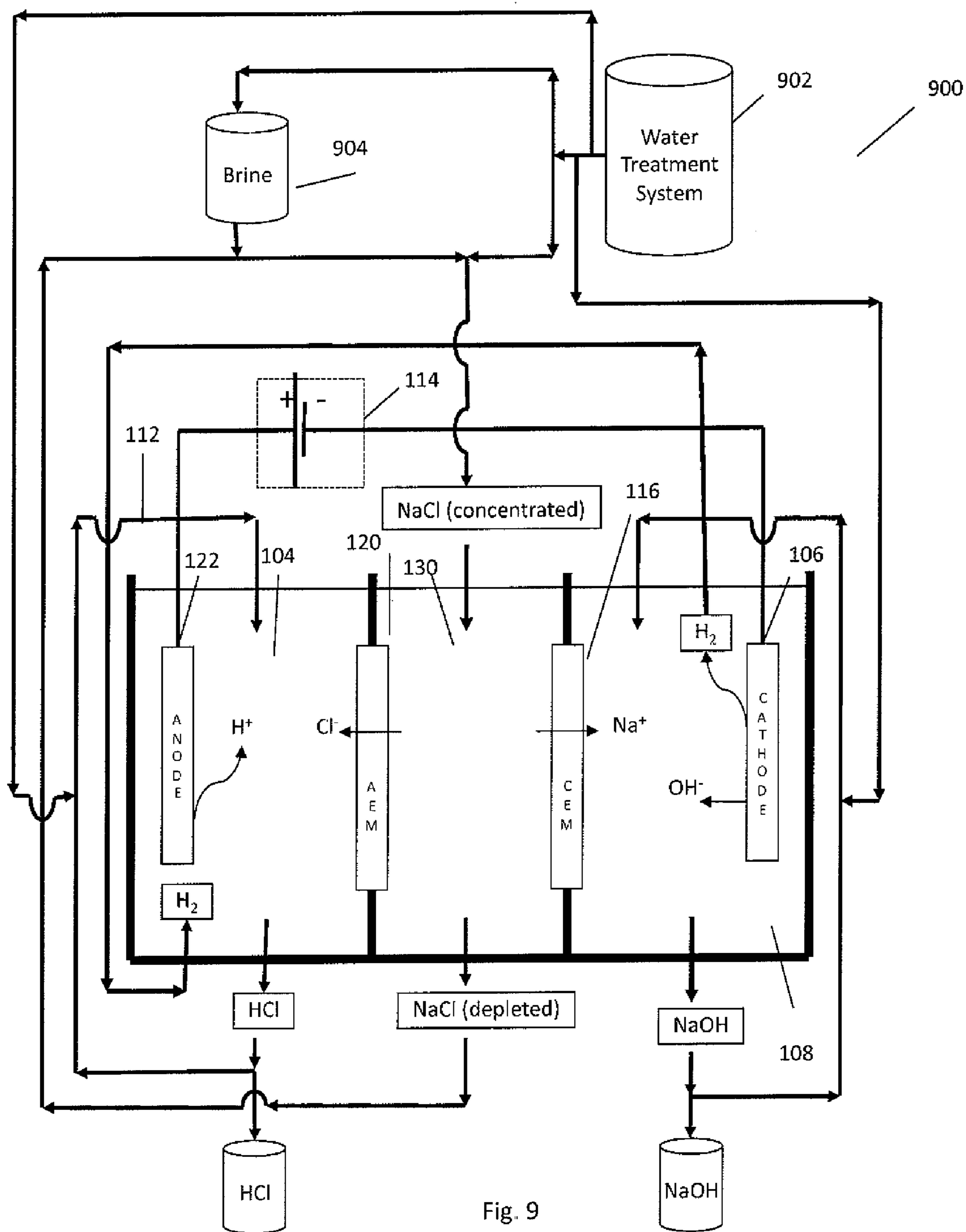

Fig. 9

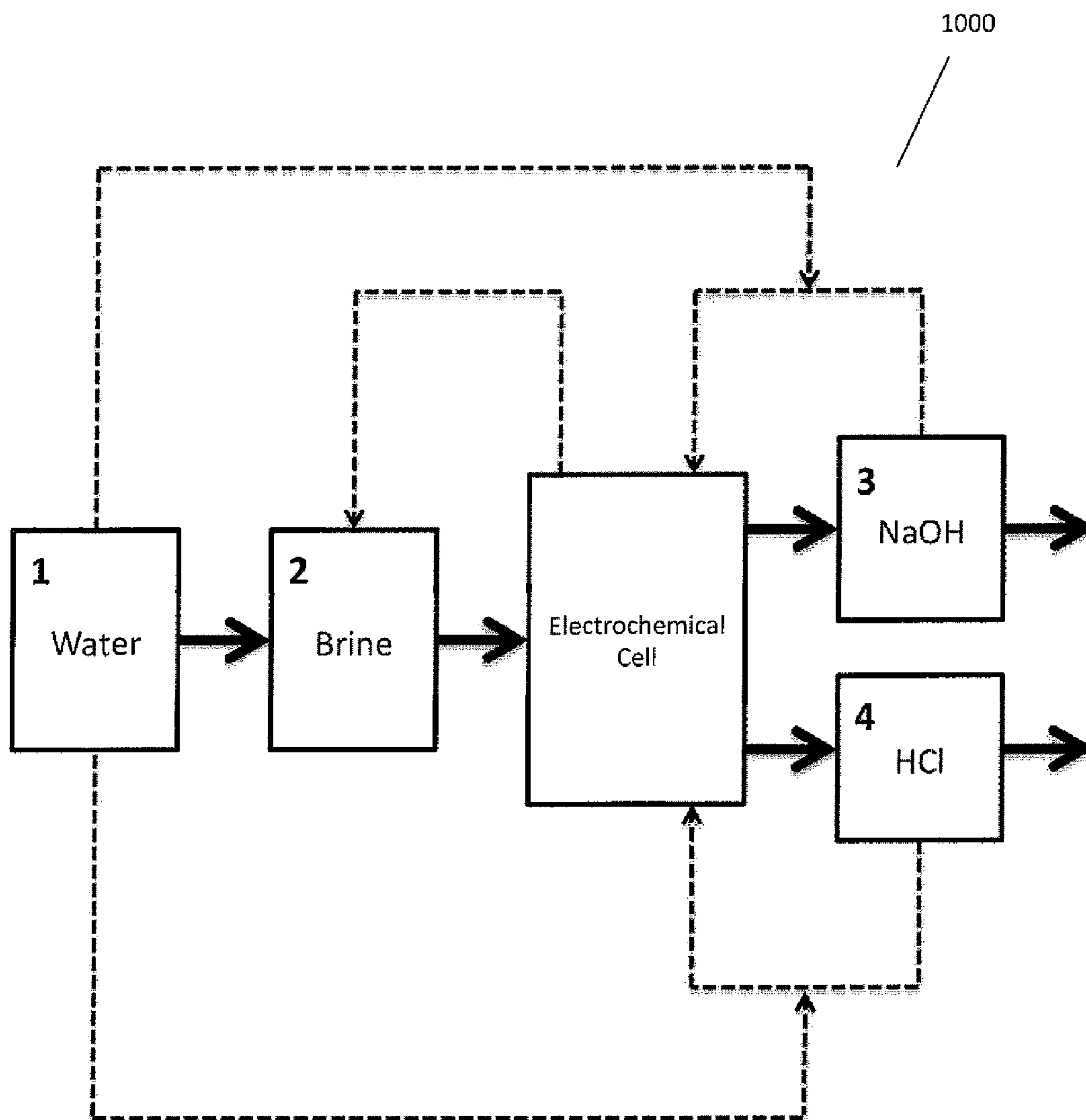

Fig. 10

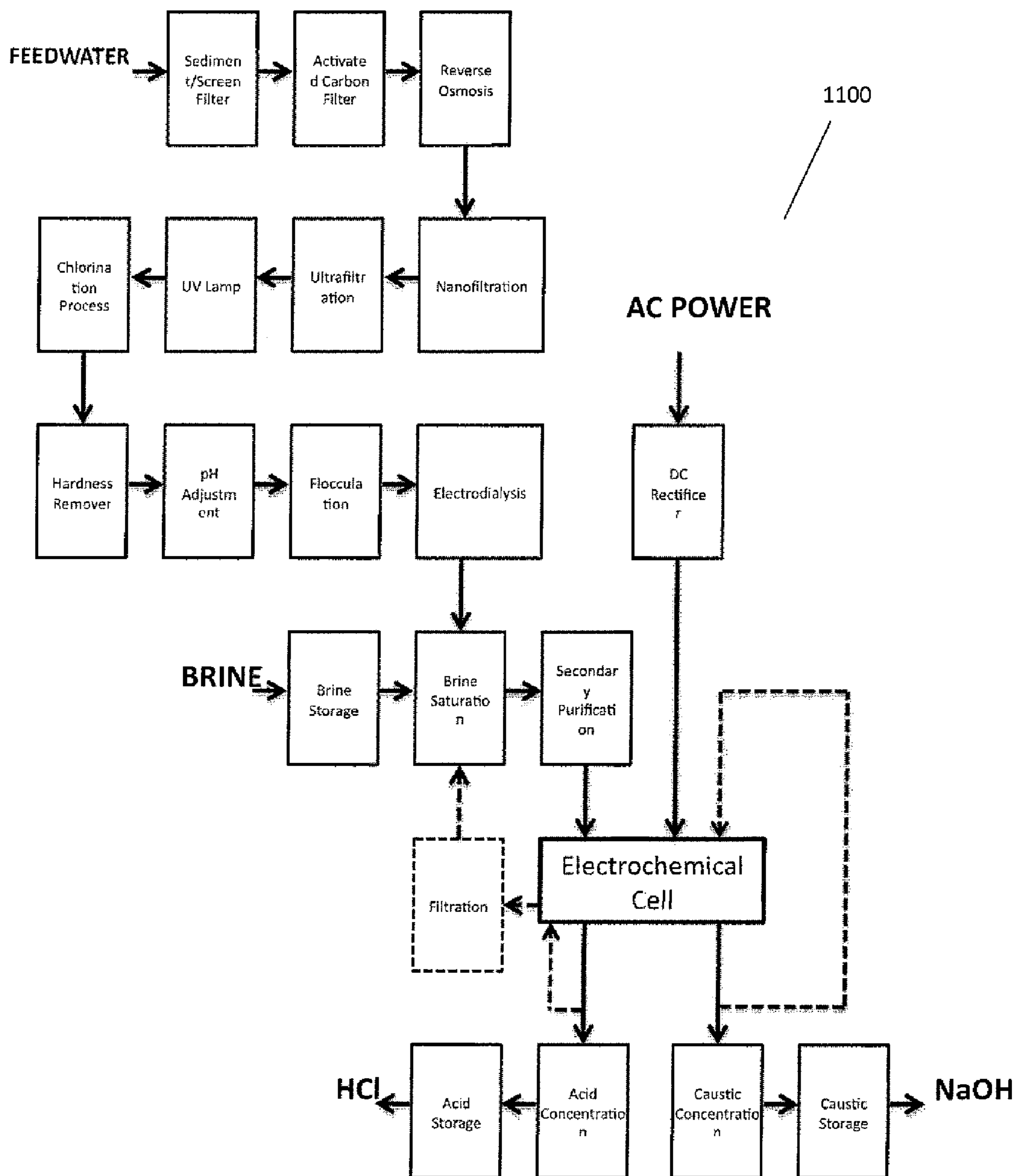

Fig. 11

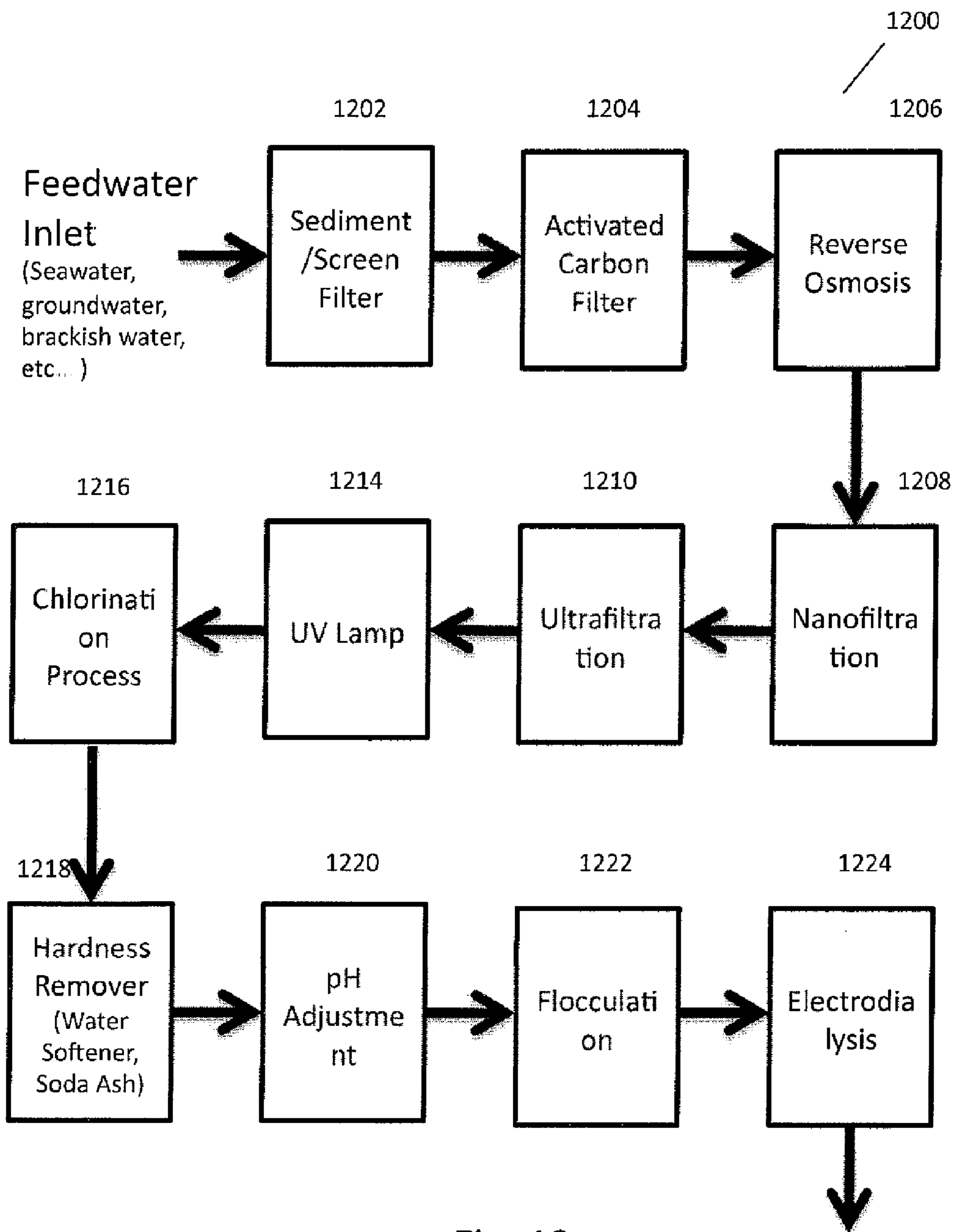

Fig. 12

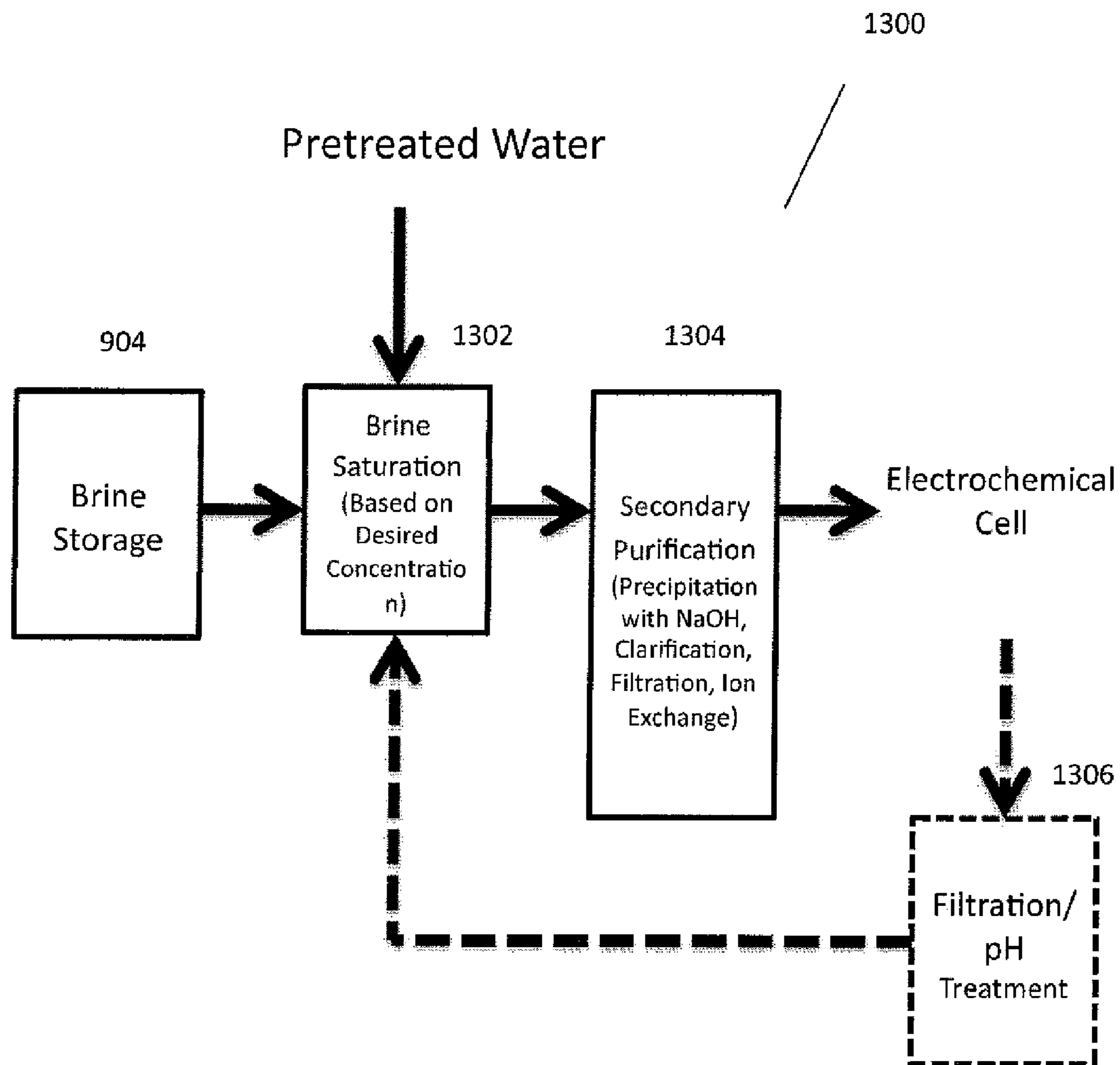

Fig. 13

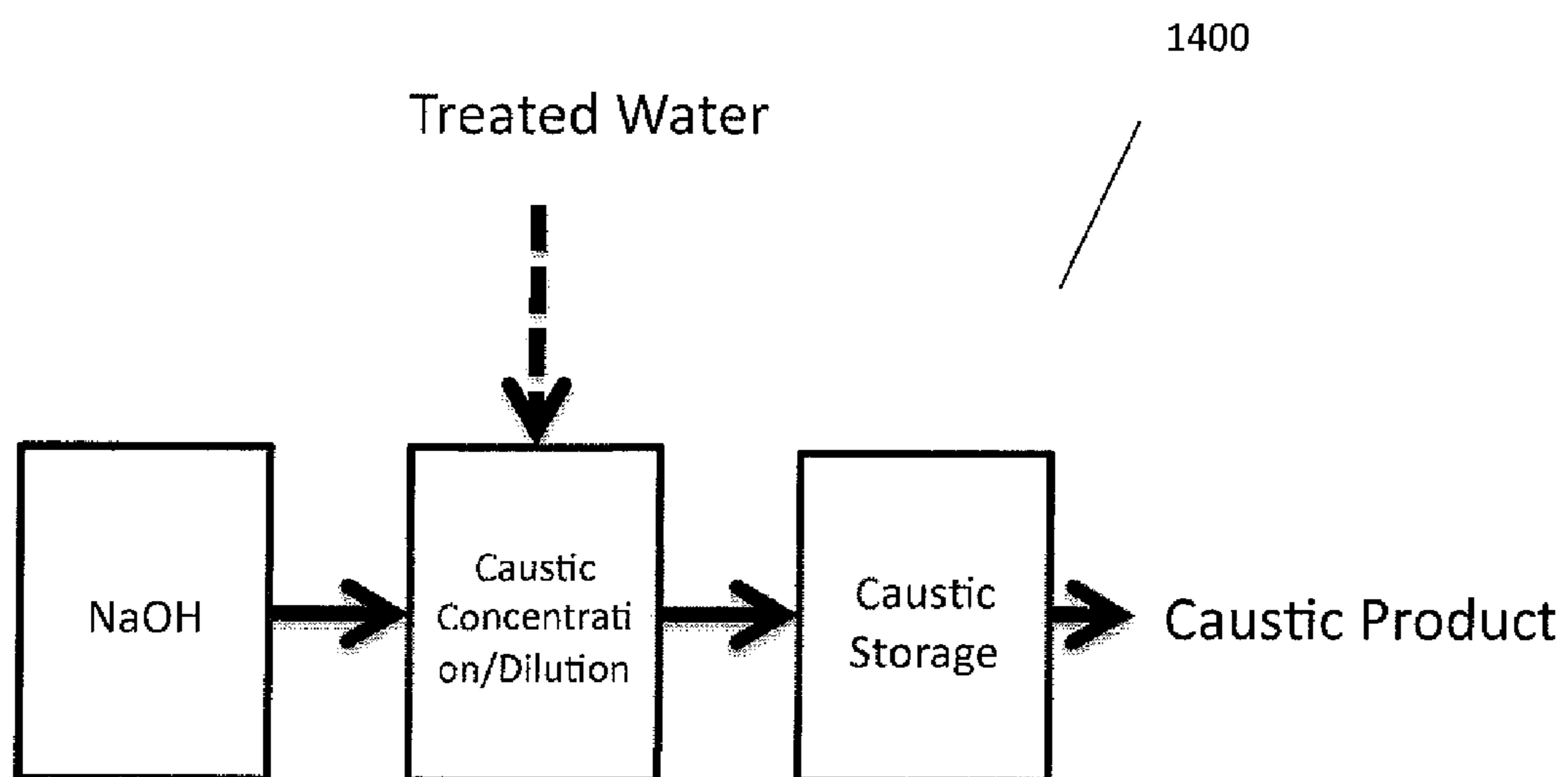

Fig. 14

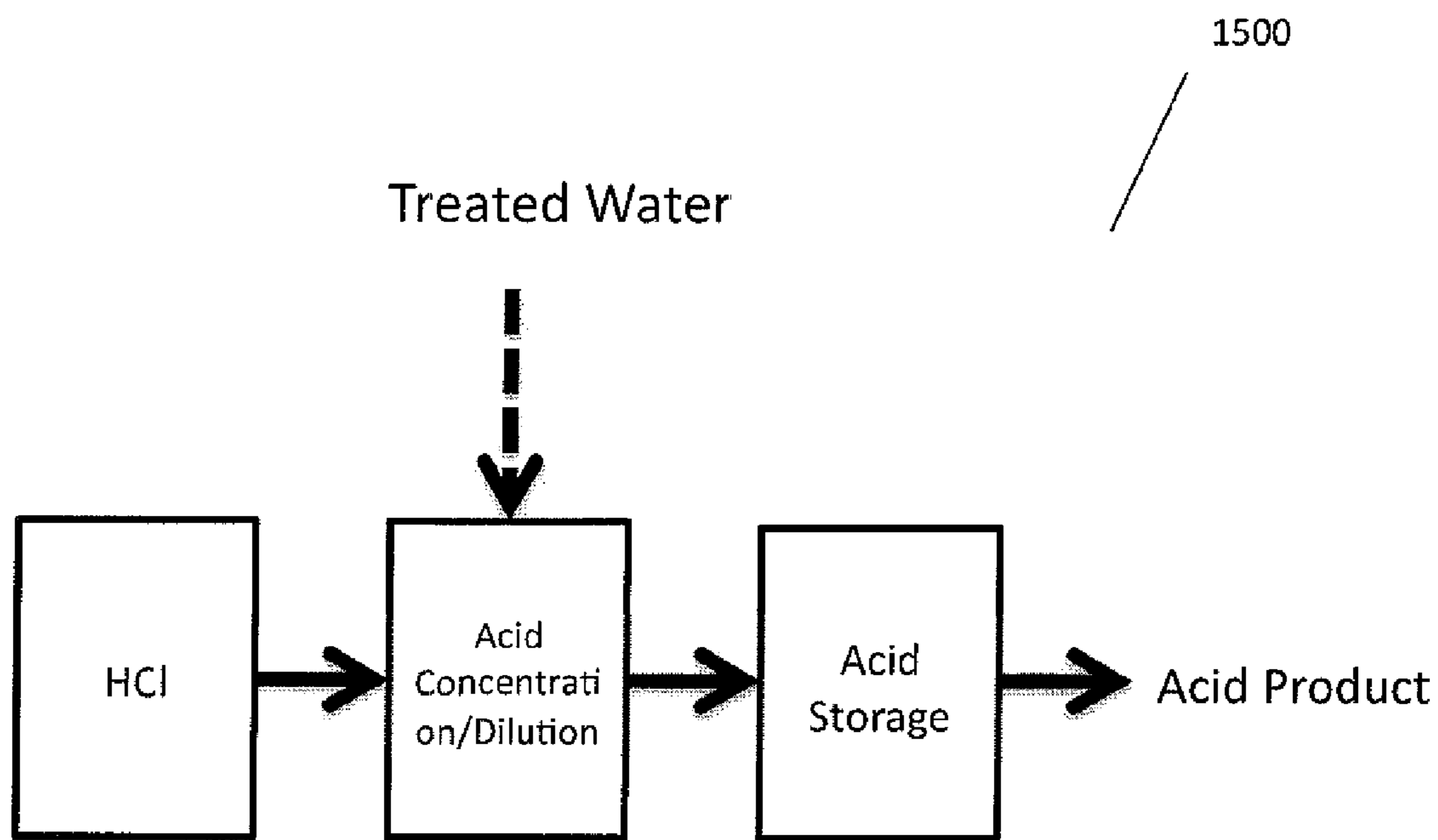

Fig. 15



## LOW-VOLTAGE ALKALINE PRODUCTION FROM BRINES

### CROSS-REFERENCE

[0001] This application claims priority to U.S. Provisional Application No. 61/151,470 filed Feb. 10, 2009 and titled "Low Voltage Electrochemical Hydroxide Saltwater and Freshwater System", herein fully incorporated by reference in its entirety.

### BACKGROUND

[0002] In many chemical processes an alkaline solution comprising, e.g., hydroxide ions and/or carbonate ions and/or bicarbonate ions is utilized to achieve a chemical reaction, e.g., to neutralize an acid, or buffer the pH of a solution, or precipitate an insoluble hydroxide and/or carbonate and/or bicarbonate from a solution. An alkaline solution can be produced by an electrochemical system that converts an aqueous salt solution to the alkaline solution and an acid as described in the above-referenced US Provisional patent application, herein incorporated by reference in its entirety. However, as the process is very energy intensive, a large amount of electrical energy is consumed; also, large amounts of salt and water are consumed. Consequently, lowering the energy and material consumed are very desirable.

### SUMMARY

[0003] This invention provides for a low-voltage, low-energy electrochemical system and method of producing an alkaline solution, comprising reducing water at the cathode to hydroxide ions and hydrogen gas, and allowing the hydroxide ions to migrate into the cathode electrolyte to produce the alkaline solution. By the system and method, at the anode, hydrogen gas is oxidized to protons without producing a gas at the anode, and the protons are allowed to migrate into the anode electrolyte or an adjacent electrolyte to produce an acid. In some embodiments, the alkaline solution further comprises bicarbonate ions and/or carbonate ions produced by adding carbon dioxide to the cathode electrolyte. In some embodiments, the alkaline solution is produced by applying less than 3V across the anode and cathode. In some embodiments, hydrogen gas produced at the cathode is recovered and directed to the anode where it is reduced to protons.

[0004] In some embodiments, a brine, e.g., subterranean brine, is utilized as a source of salt used in producing the alkaline solution; and, in some embodiments, an ion-depleted brine is produced.

[0005] In one embodiment, the system comprises an electrochemistry unit comprising a hydrogen-oxidizing anode in communication with a cathode electrolyte; wherein the electrochemistry unit is operably connected to a carbon sequestration system configured to sequester carbon dioxide with the cathode electrolyte.

[0006] In another embodiment, the system comprises a hydrogen-oxidizing anode in communication with a cathode electrolyte comprising bicarbonate ions; and a brine production system configured to provide cations to the cathode electrolyte.

[0007] In some embodiments of the system, the cathode electrolyte comprises added carbon dioxide and, in some embodiments, the cathode electrolyte comprises hydroxide ions and/or bicarbonate ions and/or carbonate ions.

[0008] In some embodiments, the system comprises cation and anion exchange membranes configured to separate cations and anions from the brine to produce an ion-depleted brine; in some embodiments, the ions comprises sodium ions and chloride ions.

[0009] In some embodiments, the system is configured to produce hydrogen gas and hydroxide ions at a cathode in contact with the cathode electrolyte, and oxidize hydrogen gas to protons at an anode in contact with an anode electrolyte without producing a gas at the anode, when a voltage is applied across the anode and cathode. In some embodiments, the voltage is less than 3V.

[0010] In some embodiments, the system is configured to produce an acid in the anode electrolyte; in some embodiments, the acid comprises hydrochloric acid.

[0011] In some embodiments, the system comprises an acid dissolution system configured to produce divalent cations with the acid; in some embodiments, the divalent cations comprise calcium ions and/or magnesium ions.

[0012] In some embodiments, the system comprises a carbon sequestration system configured to sequester carbon dioxide with the cathode electrolyte; in some embodiments, the carbon dioxide is contained in an industrial waste gas. In some embodiments, the carbon dioxide is sequestered as carbonates and/or bicarbonates; in some embodiments, the carbonates and/or bicarbonates comprise divalent cations, for example, calcium ions and/or magnesium ions.

[0013] In some embodiments, the system comprises a water treatment system configured to produce water for use in generating hydrogen gas and hydroxide ions at the cathode. In some embodiments, the water treatment system is configured to adjust the pH of electrolytes and acids in the system; and, in some embodiments, the water treatment system is configured to adjust the ionic concentration of electrolytes and acids in the system.

[0014] In some embodiments, the system comprises a desalination system configured to produce desalinated water from the depleted brine; in some embodiments, the desalinated water is operatively connected to the water treatment system.

[0015] In another embodiment, the method provides for a low-voltage, low energy electrochemical method of producing an alkaline solution comprising, oxidizing hydrogen gas to protons at a hydrogen-oxidizing anode in communication with a cathode electrolyte comprising bicarbonate ions; and providing cations to the cathode electrolyte from a brine.

[0016] In another embodiment, the method comprises oxidizing hydrogen to protons at a hydrogen-oxidizing anode in communication with a cathode electrolyte; and sequestering carbon dioxide with the cathode electrolyte

[0017] In some embodiments, the cations comprise sodium ions. In some embodiments, the method comprises adding carbon dioxide to the cathode electrolyte. In some embodiments, the method comprises producing hydrogen gas and hydroxide ions at a cathode in contact with the cathode electrolyte without producing a gas at the anode, by applying a voltage across the anode and cathode. In some embodiments, the voltage is less than 3V.

[0018] In some embodiments of the method, the cathode electrolyte comprises hydroxide ions and/or carbonate ions and/or bicarbonate ions; and in some embodiments, the method comprises separating cations and anions from the brines to produce an ion-depleted brine.

[0019] In some embodiments, the method comprises producing an acid in the cathode electrolyte; in some embodiments, the acid comprises hydrochloric acid.

[0020] In some embodiments, the method comprises using the acid in an acid dissolution system to dissolve material and produce divalent cations; in some embodiments, the divalent cations comprise calcium ions and/or magnesium ions.

[0021] In some embodiments, the method comprises configuring a carbon sequestration system to sequester carbon dioxide with the cathode electrolyte. In some embodiments, the carbon dioxide is contained in an industrial waste gas; in some embodiments, the carbon dioxide is sequestered as carbonates and/or bicarbonates; in some embodiments, the carbonates and/or bicarbonates comprise divalent cations.

[0022] In some embodiments, the method comprises using a water treatment system to dilute the cathode and anode electrolytes, the brine and the acid; in some embodiments of the method, hydrogen gas and hydroxide ions are generated at the cathode by reducing water at the cathode.

[0023] In some embodiments, the method comprises adjusting the pH of the cathode and anode electrolytes, the brine and the acid with the water; in some embodiments, the method comprises adjusting the ionic concentration in the anode and cathode electrolytes, the brine and the acid with the water.

[0024] In some embodiment, the method comprises producing desalinated water from the ion-depleted brine; in some embodiments, the desalinated water is operatively connected for use in the water treatment system.

[0025] In various embodiments, the products comprise sodium hydroxide and/or sodium bicarbonate, hydrochloric acid and an ion-depleted brine from which certain cation and anions have been removed. In some embodiments, the products are utilized to sequester carbon dioxide and other constituents of industrial waste gases, e.g., sulfur gases, nitrogen oxide gases and other combustion gases, by contacting the waste gas with a solution comprising divalent cations and the hydroxide and/or bicarbonate and/or carbonate to precipitate carbonates and/or bicarbonates as described in commonly assigned U.S. patent application Ser. No. 12/344,019 filed on Dec. 24, 2008, herein incorporated by reference in its entirety. The precipitates, comprising, e.g., calcium and/or magnesium carbonates and/or bicarbonates in various embodiments are utilized as building materials, e.g., as cements and aggregates, as described in commonly assigned U.S. patent application Ser. No. 12/126,776 filed on May 23, 2008, herein incorporated by reference in its entirety.

[0026] In another application, the ion-depleted brine from which certain cation and anions have been removed, e.g., sodium and chloride ions, is used as feed water in a desalination system where the water is further processed as described in commonly assigned U.S. patent application Ser. No. 12/163,205 filed on Jun. 27, 2008, herein incorporated by reference in its entirety.

[0027] In another embodiment, the acid produced in the anode electrolyte and/or the alkaline solution produced in the cathode electrolyte are utilized to dissolve minerals and waste materials comprising divalent cations, e.g.,  $\text{Ca}^{++}$  and  $\text{Mg}^{++}$  to produce divalent cation solutions that are utilized in producing divalent metal ion carbonate precipitates using the cathode electrolyte. In various embodiments, the precipitates are used as building materials, e.g., cement and aggregates as

described in commonly assigned U.S. patent application Ser. No. 12/126,776, herein incorporated by reference in its entirety.

[0028] Advantageously, with the present system and method, since a relatively low voltage is utilized across the anode and cathode to produce the alkaline solution, and since hydrogen gas generated at the cathode is oxidized to protons at the anode without producing a gas at the anode, a relatively low energy is utilized to produce the alkaline solution. Also, by the system and method, since carbon dioxide from industrial waste gases is utilized to produce the alkaline solution, the system and method is utilized to sequester large amounts of carbon dioxide and thus reduce carbon dioxide emissions into the atmosphere. Similarly, the acid produced is utilized in various ways including dissolving materials, e.g., minerals and biomass to produce cations for use in the system.

#### BRIEF DESCRIPTION OF THE DRAWINGS

[0029] The following are brief descriptions of drawings that illustrate embodiments of the invention:

[0030] FIG. 1 is an illustration of an embodiment of the system.

[0031] FIG. 2 is an illustration of an embodiment of the anode system.

[0032] FIG. 3 is an illustration of an embodiment of the method.

[0033] FIG. 4 is an illustration of an embodiment of the system.

[0034] FIG. 5 is an illustration of carbonate ion/bicarbonate ion speciation in water.

[0035] FIG. 6 is an illustration of an effect of adding carbon dioxide to the cathode electrolyte.

[0036] FIG. 7 is an illustration of an embodiment of the system.

[0037] FIG. 8 is a flow chart of an embodiment of the system.

[0038] FIG. 9 is an illustration of an embodiment of the brine system.

[0039] FIG. 10 is an illustration of an embodiment of the brine system.

[0040] FIG. 11 is an illustration of an embodiment of the brine system.

[0041] FIG. 12 is an illustration of an embodiment of the brine system.

[0042] FIG. 13 is an illustration of an embodiment of the brine system.

[0043] FIG. 14 is an illustration of an embodiment of the brine system.

[0044] FIG. 15 is an illustration of an embodiment of the brine system.

#### DETAILED DESCRIPTION

[0045] This invention provides for a low-voltage/low-energy system and method of producing an alkaline solution in an electrochemical system by oxidizing hydrogen at the anode to protons, and reducing water at the cathode to hydroxide ions and hydrogen at the cathode. In some embodiments, carbon dioxide is added to the cathode electrolyte to produce carbonate ions and/or bicarbonate ions in the cathode electrolyte; a gas is not produced at the anode. In some embodiments, an alkaline solution comprising, e.g., sodium hydroxide and/or sodium carbonate and/or sodium bicarbon-

ate is produced in the cathode electrolyte by applying a voltage across the anode and cathode.

**[0046]** In some embodiments, the volts is less than 3V. In some embodiments, subterranean brine is utilized as a source of salt/cations/anions used in producing the alkaline solution.

**[0047]** In some embodiments, an acid, e.g., hydrochloric acid, is produced in the anode electrolyte from hydrogen ions, produced at the anode and migrated from the anode into the anode, and cations in the cations in the electrolyte, e.g., chloride ions.

**[0048]** In some embodiments, the acid is utilized to dissolve a material, e.g., a mineral, e.g., serpentine or olivine, to provide divalent cation solution, e.g., calcium and magnesium ions, which may in some embodiments be used with the alkaline solution to precipitate carbonates and/or bicarbonates derived from carbon dioxide in a waste gas stream, e.g., carbon dioxide in the exhaust gases of a fossil fuelled power generating plant or a cement producing plant. In some embodiments, sodium chloride solution is used as the anode electrolyte.

**[0049]** In some embodiments, on applying a voltage across the anode and cathode, cations, e.g., sodium ions in the anode electrolyte, migrate from the salt solution through a cation exchange membrane into the cathode electrolyte to produce an alkaline solution comprising, e.g., sodium hydroxide and/or sodium carbonate and/or sodium bicarbonate in the cathode electrolyte; concurrently, anions in the salt solution, e.g., chloride ions, migrate into the anode electrolyte to produce an acid, e.g., hydrochloric acid, with in the protons that form at the anode.

**[0050]** In some embodiments, hydrogen gas and hydroxide ions are produced at the cathode, and in some embodiments, some or all of the hydrogen gas produced at the cathode is directed to the anode where it is oxidized to produce hydrogen ions.

**[0051]** As can be appreciated by one ordinarily skilled in the art, since the embodiments herein can be configured with an alternative or equivalent salt, e.g., a potassium sulfate solution, to produce an equivalent alkaline solution, e.g., potassium hydroxide and/or potassium carbonate and/or potassium bicarbonate in the cathode electrolyte, and an alternative acid, e.g., sulfuric acid in the anode electrolyte, by applying the voltage herein across the anode and cathode, the invention is not limited to the exemplary embodiments described herein, but is useable with an equivalent salt, e.g., potassium sulfate, to produce an alkaline solution in the cathode electrolyte, e.g., potassium carbonate and/or potassium bicarbonate and an acid, e.g., sulfuric acid in the anode electrolyte. Accordingly, to the extent that such equivalents are based on or are suggested by the embodiment herein, these equivalents are within the scope of the appended claims.

**[0052]** In the following detailed description, embodiments of the system and method are described with reference to the one or more illustrated Figures. However, it should be understood that this description is illustrative and is not restrictive since the invention is adaptable for use with other cell configurations including a one-cell, a two-cell, three-cell and other multi-cell configurations, not described in detail herein but are reasonably contemplated.

**[0053]** Similarly, it should be understood that although the invention is described with particularity with use of a brine comprising sodium ions and chloride ions, this description also is also illustrative and not restrictive since the invention is adaptable for use with equivalent aqueous salt, e.g., sulfates

and nitrates and like, e.g., potassium sulfate, as can be appreciated by those ordinarily skilled in the art.

**[0054]** With reference to FIGS. 1-15, in some embodiments, carbon dioxide is added to the cathode electrolyte utilizing a gas mixer/gas absorber. In one embodiment, the gas mixer/gas absorber comprises a series of spray nozzles that produces a flat sheet or curtain of liquid into which the gas is absorbed; in another embodiment, the gas mixer/gas absorber comprises a spray absorber that creates a mist and into which the gas is absorbed; in other embodiments, other commercially available gas/liquid absorber, e.g., an absorber available from Neumann Systems, Colorado, USA is used.

**[0055]** The carbon dioxide added to the cathode electrolyte may be obtained from various industrial sources that release carbon dioxide including carbon dioxide from combustion gases of fossil fuelled power plants, e.g., conventional coal, oil and gas power plants, or IGCC (Integrated Gasification Combined Cycle) power plants that generate power by burning syngas; cement manufacturing plants that convert limestone to lime; ore processing plants; fermentation plants; and the like. In some embodiments, the carbon dioxide may comprise other gases, e.g., nitrogen, oxides of nitrogen (nitrous oxide, nitric oxide), sulfur and sulfur gases (sulfur dioxide, hydrogen sulfide), and vaporized materials.

**[0056]** In some embodiments, the system includes a gas treatment system that removes constituents in the carbon dioxide gas stream before the carbon dioxide is utilized in the cathode electrolyte. In some embodiments, a portion of, or the entire amount of, cathode electrolyte comprising bicarbonate ions and/or carbonate ions and/or hydroxide ions is withdrawn from the system and is contacted with carbon dioxide gas in an exogenous carbon dioxide gas/liquid contactor to increase the absorbed carbon dioxide content in the solution. In some embodiments, the solution enriched with carbon dioxide is returned to the cathode compartment; in other embodiments, the solution enriched with carbon dioxide is reacted with a solution comprising divalent cations to produce divalent cation hydroxides, carbonates and/or bicarbonates.

**[0057]** In some embodiments, the pH of the cathode electrolyte is adjusted upwards by hydroxide ions that migrate from the cathode, and/or downwards by dissolving carbon dioxide gas in the cathode electrolyte to produce carbonic acid and carbonic ions that react with and remove hydroxide ions. Thus it can be appreciated that the pH of the cathode electrolyte is determined, at least in part, by the balance of these two processes.

**[0058]** Referring to FIG. 1, the system 100 in one embodiment comprises a gas diffusion anode 102 and a cathode 106 in contact with a cathode electrolyte 108, 108A, 108B comprising dissolved carbon dioxide 107A. The system in some embodiments includes a hydrogen gas delivery system 112 configured to deliver hydrogen gas to the anode 102; in some embodiments, the hydrogen gas is obtained from the cathode 106. In the system, the anode 102 is configured to produce protons, and the cathode 106 is configured to produce hydroxide ions and hydrogen gas when a low voltage 114, e.g., less than 2V is applied across the anode and the cathode. In the system, a gas is not produced at the anode 102.

**[0059]** As is illustrated in FIG. 1, first cation exchange membrane 116 is positioned between the cathode electrolyte 108, 108 A, 108B and a salt solution 118; and an anion exchange membrane 120 is positioned between the salt solution 118 and the anode electrolyte 104 in a configuration

where the anode electrolyte **104** is separated from the anode **102** by second cation exchange membrane **122**. In the system, the second cation exchange membrane **122** is positioned between the anode **102** and the anode electrolyte **104** such that anions may migrate from the salt solution **118** to the anode electrolyte **104** through the anion exchange membrane **120**; however, anions are prevented from contacting the anode **102** by the second cation exchange membrane **122** adjacent to the anode **102**.

[0060] In some embodiments, the system is configurable to migrate anions, e.g., chloride ions, from the salt solution **118** to the anode electrolyte **104** through the anion exchange membrane **120**; migrate cations, e.g., sodium ions from the salt solution **118** to the cathode electrolyte **108**, **108A**, **108B** through the first cation exchange membrane **116**; migrate protons from the anode **102** to the anode electrolyte **104**; and migrate hydroxide ions from the cathode **106** to the cathode electrolyte **108**, **108A**, **108B**. Thus, in some embodiments, the system can be configured to produce sodium hydroxide and/or sodium bicarbonate and/or sodium carbonate in the cathode electrolyte **108**, **108A**, **108B**; and produce an acid e.g., hydrochloric acid **124** in the anode electrolyte.

[0061] In some embodiments as illustrated in FIG. 1, the system comprises a partition **126** that partitions the cathode electrolyte **108** into a first cathode electrolyte portion **108A** and a second cathode electrolyte portion **108B**, wherein the second cathode electrolyte portion **108B**, comprising dissolved carbon dioxide, contacts the cathode **106**; and wherein the first cathode electrolyte portion **108A** comprising dissolved carbon dioxide and gaseous carbon dioxide is in contact with the second cathode electrolyte portion **108B** under the partition **126**. In the system, the partition is positioned in the cathode electrolyte such that a gas, e.g., carbon dioxide in the first cathode electrolyte portion **108A** is isolated from cathode electrolyte in the second cathode electrolyte portion **108B**. Thus, for example, where a gas, e.g., hydrogen, is generated at the cathode and it is desired to separate this cathode gas from a gas or vapor that may evolve from the cathode electrolyte, the partition may serve as a means to prevent mixing of the gases from the cathode and the gases and or vapor from the cathode electrolyte. While this system is illustrated in FIG. 1, it is applicable to any of the electrochemical system described herein, e.g., the systems illustrated in FIGS. 4, 7 and 8.

[0062] Thus, in some embodiments, on applying the present voltage across the anode and cathode, the system can be configured to produce hydroxide ions and hydrogen gas at the cathode **106**; migrate hydroxide ions from the cathode into the cathode electrolyte **108**, **108B**, **108A**; migrate cations from the salt solution **118** to the cathode electrolyte through the first cation exchange membrane **116**; migrate chloride ions from the salt solution **118** to the anode electrolyte **104** through the anion exchange membrane **120**; and migrate protons from the anode **102** to the anode electrolyte **104**. Hence, depending on the salt solution **118** used, the system can be configured to produce an alkaline solution, e.g., sodium hydroxide in the cathode electrolyte.

[0063] In some embodiments, the system is operatively connected to a carbon dioxide gas/liquid contactor **128** configured to remove cathode electrolyte from the system and dissolve carbon dioxide in the cathode electrolyte in the gas/liquid contactor before the cathode electrolyte is returned to the system.

[0064] In other embodiments, the cathode electrolyte is operatively connected to a system (not shown) that is configured to precipitate divalent cation carbonates and/or divalent cation bicarbonates and/or divalent cation hydroxides from a solution comprising carbon dioxide gas and divalent cations.

[0065] FIG. 2 illustrates a schematic of a suitable gas diffusion anode that can be used in embodiments of the system described herein. In some embodiments, the gas diffusion anode comprises a conductive substrate **130** infused with a catalyst **136** that is capable of catalyzing the oxidation of hydrogen gas to protons when the present voltages are applied across the anode and cathode. In some embodiments, the anode comprises a first side **132** that interfaces with hydrogen gas provided to the anode, and an opposed second side **134** that interfaces with the anode electrolyte **104**. In some embodiments, the portion of the substrate **132** that interfaces with the hydrogen gas is hydrophobic and is relatively dry; and the portion of the substrate **134** that interfaces with the anode electrolyte **104** is hydrophilic and may be wet, which facilitates migration of protons from the anode to the anode electrolyte. In various embodiments, the substrate is porous to facilitate the movement of gas from the first side **132** to the catalyst **136** that may be located on second side **134** of the anode; in some embodiments, the catalyst may also be located within the body of the substrate **130**. The substrate **130** may be selected for its hydrophilic or hydrophobic characteristics as described herein, and also for its low ohmic resistance to facilitate electron conduction from the anode through a current collector connected to the voltage supply **114**; the substrate may also be selected for its porosity to ion migration, e.g., proton migration, from the anode to the anode electrolyte **116**.

[0066] In some embodiments, the catalyst may comprise platinum, ruthenium, iridium, rhodium, manganese, silver or alloys thereof. Suitable gas diffusion anodes are available commercially, e.g., from E-TEK (USA) and other suppliers. In some embodiments of the anode as is illustrated in FIG. 8, the anode comprises a ion exchange membrane, e.g., a cation exchange membrane **122** that contacts the second side **134** of the anode. In such embodiments, the ion exchange membrane can be used to allow or prevent migration of ions to or from the anode. Thus, for example, with reference to FIG. 8, when protons are generated at the anode, a cation exchange membrane may be used to facilitate the migration of the protons from the anode and/or block the migration of ions, e.g., cations to the substrate. In the some embodiments, the ion exchange membrane may be selected to preferentially allow passage of one type of cation, e.g., hydrogen ions, while preventing the passage of another type of ions, e.g., sodium ions.

[0067] As is illustrated in FIG. 1, the system includes a salt solution **118** located between the anode electrolyte **104** and the cathode electrolyte **108**, **108A**, **108B**. In some embodiments, the cathode electrolyte is separated from the salt solution by a first cation exchange membrane **116** that allows migration of cations, e.g., sodium ions, from the salt solution to the cathode electrolyte. The first cation exchange membrane **116** is also capable of blocking the migration of anions from the cathode electrolyte **108**, **108A**, **108B** to the salt solution **118**. In some embodiments, the anode electrolyte **104** is separated from the salt solution **118** by an anion exchange membrane **108** that will allow migration of anions, e.g., chloride ions, from the salt solution **118** to the anode electrolyte **104**. The anion exchange membrane, however,

will block the migration of cations, e.g., protons from the anode electrolyte **104** to the salt solution **118**.

[0068] With reference to FIGS. **1** and **2**, the system includes a hydrogen gas supply system **112** configured to provide hydrogen gas to the anode **102**. The hydrogen may be obtained from the cathode **106** or may be obtained from external source, e.g., from a commercial hydrogen gas supplier, e.g., at start-up of the system when the hydrogen supply from the cathode is insufficient. In the system, the hydrogen gas is oxidized to protons and electrons; un-reacted hydrogen gas is recovered and circulated **140** at the anode.

[0069] Referring to FIG. **1**, in operation, the cathode electrolyte **108**, **108A**, **108B** is initially charged with an alkaline electrolyte, e.g., sodium hydroxide solution, and the anode electrolyte **104** is initially charged with an acidic electrolyte, e.g., dilute hydrochloric acid. The cathode electrolyte is also initially charged with carbon dioxide gas **107A**, **128**, and hydrogen gas is provided to the anode. In the system, on applying a voltage across the anode and cathode, protons produced at the anode will enter into the anode electrolyte and attempt to migrate from the anode electrolyte **104** to the cathode **106** via the salt solution **118** between the cathode and anode. However, since the anion exchange membrane will block the migration of protons to the salt solution, the protons will accumulate in the anode electrolyte **104**.

[0070] Simultaneously at the cathode **106**, the voltage across the anode and cathode will produce hydroxide ions and hydrogen gas at the cathode. In some embodiments, the hydrogen produced at the cathode is recovered and directed to the anode **102** where it is oxidized to protons. In the system, hydroxide ions produced at the cathode **106** will enter into the cathode electrolyte **108**, **108A**, **108B** from where they will attempt to migrate to the anode **102** via the salt solution **118** between the cathode and anode. However, since the cathode electrolyte **108**, **108A**, **108B** is separated from the salt solution electrolyte by the first cation exchange membrane **116** which will block the passage of anions, the first cation exchange membrane will block the migration of hydroxide ions from the cathode electrolyte to the salt solution; consequently, the hydroxide ions will accumulate in the cathode electrolyte **108**, **108A**, **108B**.

[0071] In the system as illustrated in FIG. **1**, with the voltage across the anode and cathode, since the salt solution is separated from the cathode electrolyte by the first cation exchange membrane **116**, cations in the salt solution, e.g., sodium ions, will migrate through the first cation exchange membrane **116** to the cathode electrolyte **108**, **108A**, **108B**, and anions, e.g., chloride ions, will migrate to the anode electrolyte through the anion exchange membrane **120**. Consequently, in the system, as illustrated in FIG. **1**, an acid, e.g., hydrochloric acid **124** will be produced in the anode electrolyte **104**, and alkaline solution, e.g., sodium hydroxide will be produced in the cathode electrolyte. As can be appreciated, with the migration of cations and anions from the salt solution, the system in some embodiments can be configured to produce a partly de-ionized salt solution, e.g., an ion-depleted brine, from salt solution **118**. In some embodiments, this partially de-ionized salt solution can be used as feed-water to a desalination facility (not shown) where it can be further processed to produce desalinated water as described in commonly assigned U.S. patent application Ser. No. 12/163,205 filed on Jun. 27, 2008, herein incorporated by reference in its entirety; alternatively, the solution can be used in industrial and agricultural applications where its salinity is acceptable.

[0072] With reference to FIG. **1**, the system in some embodiments includes a second cation exchange membrane **124**, attached to the anode substrate **105**, such that it separates the anode **102** from the anode electrolyte. In this configuration, as the second cation exchange membrane **122** is permeable to cations, protons formed at the anode will migrate to the anode electrolyte as described herein; however, as the second cation exchange membrane **122** is impermeable to anions, anions, e.g., chloride ions, in the anode electrolyte will be blocked from migrating to the anode **102**, thereby avoiding interaction between the anode and the anions that may interact with the anode, e.g., by corrosion.

[0073] With reference to FIG. **1**, in some embodiments, the system includes a partition **128** configured into J-shape structure and positioned in the cathode electrolyte **108**, **108A**, **108B** to define an upward-tapering channel **144** in the upper portion of the cathode electrolyte compartment. The partition also defines a downward-tapering channel **146** in lower portion of the cathode electrolyte. Thus, with the partition in the place, the cathode electrolyte **108** is partitioned into the first cathode electrolyte portion **108A** and a second cathode electrolyte portion **108B**. As is illustrated in FIG. **1**, cathode electrolyte in the first cathode electrolyte portion **108A** is in contact with cathode electrolyte in the second cathode electrolyte portion **108B**; however, a gas in the first electrolyte portion **108A**, e.g., carbon dioxide, is prevented from mixing with cathode electrolyte in the second cathode electrolyte **108B**. Although this is illustrated in for the system of FIG. **1**, such a configuration may be used in any system where it is desired to partition an electrolyte solution, e.g., a cathode electrolyte such that a gas that is introduced into one portion remains separate from another portion. For example, such a configuration may be used in any system as described herein as, e.g., in FIGS. **7** and **8**.

[0074] With reference to FIG. **1**, the system in some embodiments includes a cathode electrolyte circulating system **142** adapted for withdrawing and circulating cathode electrolyte in the system. In one embodiment, the cathode electrolyte circulating system comprises a carbon dioxide gas/liquid contactor **128** that is adapted for dissolving carbon dioxide in the circulating cathode electrolyte, and for circulating the electrolyte in the system. As can be appreciated, since the pH of the cathode electrolyte can be adjusted by withdrawing and/or circulating cathode electrolyte from the system, the pH of the cathode electrolyte compartment can be regulated by regulating an amount of cathode electrolyte removed from the system through the carbon dioxide gas/liquid contactor **128**.

[0075] In an alternative as illustrated in FIG. **4**, the system comprises a cathode **106** in contact with a cathode electrolyte **108** and an anode **102** in contact with an anode electrolyte **104**. In this system, the cathode electrolyte comprises a salt solution, a brine that functions as the cathode electrolyte as well as a source of chloride and sodium ions for the alkaline and acid solution produced in the system. In this system, the cathode electrolyte is separated from the anode electrolyte by an anion exchange membrane **120** that allows migration of anions, e.g., chloride ions, from the salt solution to the anode electrolyte. As is illustrated in FIG. **4**, the system includes a hydrogen gas delivery system **112** configured to provide hydrogen gas to the anode. The hydrogen may be obtained from the cathode and/or obtained from an external source, e.g., a commercial hydrogen gas supplier e.g., at start-up of operations when the hydrogen supply from the cathode is

insufficient. In some embodiments, the hydrogen delivery system is configured to deliver hydrogen gas to the anode where oxidation of the gas is catalyzed to protons and electrons. In some embodiments, un-reacted hydrogen gas in the system is recovered and re-circulated to the anode.

[0076] Referring to FIG. 4 wherein the salt solution, e.g., concentrated NaCl solution, is added directly to the cathode electrolyte 108, as with the system of FIG. 1, on applying a voltage across the anode and cathode, protons produced at the anode from oxidation of hydrogen will enter into the anode electrolyte from where they will attempt to migrate to the cathode electrolyte across the anion exchange membrane 120. However, since the anion exchange membrane 120 will block the passage of cations, the protons will accumulate in the anode electrolyte. At the same time, however, the anion exchange membrane 120 being pervious to anions will allow the migration of anions, e.g., chloride ions from the cathode electrolyte to the anode, thus in this embodiment, chloride ions will migrate to the anode electrolyte to produce hydrochloric acid in the anode electrolyte. In this system, the voltage across the anode and cathode is adjusted to a level such that hydroxide ions and hydrogen gas are produced at the cathode without producing a gas, e.g., chlorine or oxygen, at the anode. In this system, since cations will not migrate from the cathode electrolyte across the anion exchange membrane 116, sodium ions will accumulate in the cathode electrolyte 108 to produce an alkaline solution with hydroxide ions produced at the cathode. In embodiments where carbon dioxide gas is dissolved in the cathode electrolyte, sodium ions may also produce sodium bicarbonate and/or sodium carbonate in the cathode electrolyte as described herein with reference to FIG. 1.

[0077] With reference to FIG. 1, depending on the pH of the cathode electrolyte, carbon dioxide gas introduced into the first cathode electrolyte portion 108A will dissolve in the cathode electrolyte and reversibly dissociate and equilibrate to produce carbonic acid, protons, carbonate ions and/or bicarbonate ions in the first cathode electrolyte compartment as follows:

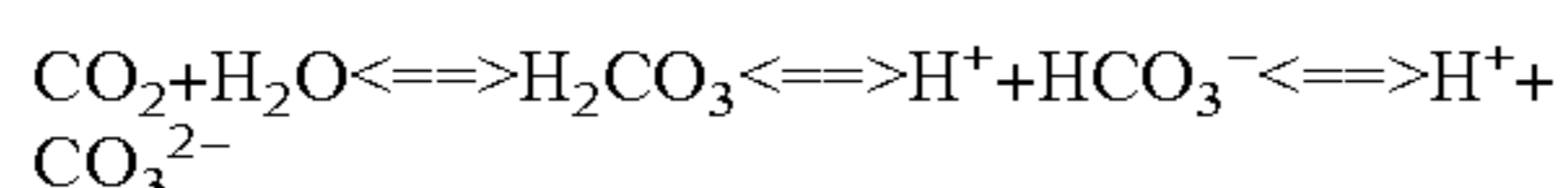

In the system, as cathode electrolyte in the first cathode electrolyte portion 108A may mix with second cathode electrolyte portion 108B, the carbonic acid, bicarbonate and carbonate ions formed in the first cathode electrolyte portion 108A by absorption of carbon dioxide in the cathode electrolyte may migrate and equilibrate with cathode electrolyte in the second cathode electrolyte portion 108B. Thus, in some embodiments, first cathode electrolyte portion 108A may comprise dissolved and un-dissolved carbon dioxide gas, and/or carbonic acid, and/or bicarbonate ions and/or carbonate ions; while second cathode electrolyte portion 108B may comprise dissolved carbon dioxide, and/or carbonic acid, and/or bicarbonate ions and/or carbonate ions.

[0078] With reference to FIG. 1, on applying a voltage across anode 102 and cathode 108, the system 100 may produce hydroxide ions and hydrogen gas at the cathode from reduction of water, as follows:

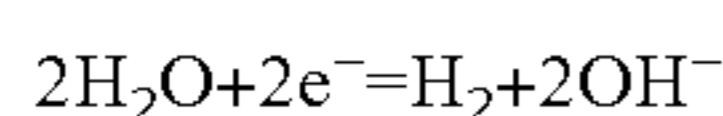

As cathode electrolyte in first cathode electrolyte portion 108A can intermix with cathode electrolyte in second cathode electrolyte portion 108B, hydroxide ions formed in the second cathode electrolyte portion may migrate and equilibrate

with carbonate and bicarbonate ions in the first cathode electrolyte portion 108A. Thus, in some embodiments, the cathode electrolyte in the system may comprise hydroxide ions and dissolved and/or un-dissolved carbon dioxide gas, and/or carbonic acid, and/or bicarbonate ions and/or carbonate ions. In the system, as the solubility of carbon dioxide and the concentration of bicarbonate and carbonate ions in the cathode electrolyte are dependent on the pH of the electrolyte, the overall reaction in the cathode electrolyte 104 is either:

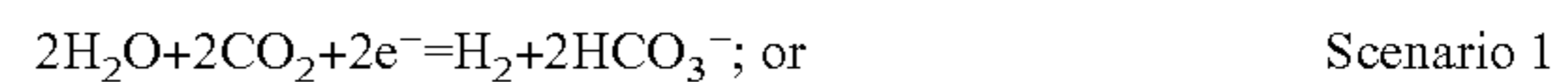

or a combination of both, depending on the pH of the cathode electrolyte. This is illustrated in the carbonate speciation diagram in FIG. 5.

[0079] For either scenario, the overall cell potential of the system can be determined through the Gibbs energy change of the reaction by the formula:

$$E_{\text{cell}} = -\Delta G/nF$$

Or, at standard temperature and pressure conditions:

$$E^\circ_{\text{cell}} = -\Delta G^\circ/nF$$

where,  $E_{\text{cell}}$  is the cell voltage,  $\Delta G$  is the Gibbs energy of reaction,  $n$  is the number of electrons transferred, and  $F$  is the Faraday constant (96485 J/Vmol). The  $E_{\text{cell}}$  of each of these reactions is pH dependent based on the Nernst equation as is illustrated in FIG. 6 and as discussed below.

[0080] For either scenario, the overall cell potential can be determined through the combination of Nernst equations for each half cell reaction:

$$E = E^\circ - RT \ln(Q)/nF$$

where,  $E^\circ$  is the standard reduction potential,  $R$  is the universal gas constant, (8.314 J/mol K)  $T$  is the absolute temperature,  $n$  is the number of electrons involved in the half cell reaction,  $F$  is Faraday's constant (96485 J/V mol), and  $Q$  is the reaction quotient such that:

$$E_{\text{total}} = E_{\text{cathode}} + E_{\text{anode}}$$

When hydrogen is oxidized to protons at the anode as follows:

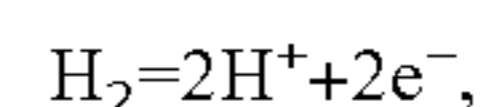

$E^\circ$  is 0.00 V,  $n$  is 2, and  $Q$  is the square of the activity of  $\text{H}^+$  so that:

$$E_{\text{anode}} = +0.059 \text{ pH}_a,$$

where  $\text{pH}_a$  is the pH of the anode electrolyte.

When water is reduced to hydroxide ions and hydrogen gas at the cathode as follows:

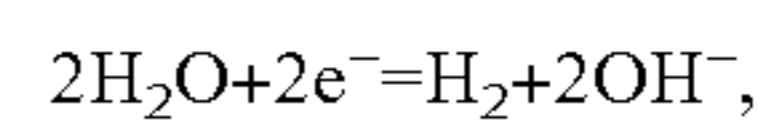

$E^\circ$  is  $-0.83$  V,  $n$  is 2, and  $Q$  is the square of the activity of  $\text{OH}^-$  so that:

$$E_{\text{cathode}} = -0.059 \text{ pH}_c,$$

where  $\text{pH}_c$  is the pH of the cathode electrolyte.

[0081] For either Scenario, the  $E$  for the cathode and anode reactions varies with the pH of the anode and cathode electrolytes. Thus, for Scenario 1 if the anode reaction, which is occurring in an acidic environment, is at a pH of 0, then the  $E$  of the reaction is 0V for the half cell reaction. For the cathode reaction, if the generation of bicarbonate ions occur at a pH of 7, then the theoretical  $E$  is  $7 \times (-0.059 \text{ V}) = -0.413 \text{ V}$  for the half cell reaction where a negative  $E$  means energy is needed to be

input into the half cell or full cell for the reaction to proceed. Thus, if the anode pH is 0 and the cathode pH is 7 then the overall cell potential would be  $-0.413\text{V}$ , where:

$$E_{total} = 0.059(\text{pH}_a - \text{pH}_c) = -0.059\Delta\text{pH}.$$

**[0082]** For Scenario 2 in which carbonate ions are produced, if the anode pH is 0 and the cathode pH is 10, this would represent an E of 0.59 V.

**[0083]** Thus, in some embodiments, directing  $\text{CO}_2$  gas into the cathode electrolyte may lower the pH of the cathode electrolyte by producing bicarbonate ions and/or carbonate ions in the cathode electrolyte, which consequently may lower the voltage across the anode and cathode in producing hydroxide, carbonate and/or bicarbonate in the cathode electrolyte.

**[0084]** Thus, if the cathode electrolyte is allowed to increase to a pH of 14 or greater, the difference between the anode half-cell potential (represented as the thin dashed horizontal line, Scenario 1, above) and the cathode half cell potential (represented as the thick solid sloping line in Scenario 1, above) will increase to 0.83V. With increased duration of cell operation without  $\text{CO}_2$  addition or other intervention, e.g., diluting with water, the required cell potential will continue to increase. The cell potential may also increase due to ohmic resistance losses across the membranes in the electrolyte and the cell's overvoltage potential.

**[0085]** Herein, an overvoltage potential refers to the voltage difference between a thermodynamically determined half-cell reduction potential, and the experimentally observed potential at which the redox reaction occurs. The term is related to a cell voltage efficiency as the overvoltage potential requires more energy than is thermodynamically required to drive a reaction. In each case, the extra energy is lost as heat. Overvoltage potential is specific to each cell design and will vary between cells and operational conditions even for the same reaction.

**[0086]** In embodiments wherein it is desired to produce bicarbonate and/or carbonate ions in the cathode electrolyte, the system as illustrated in FIGS. 1-2, and as described above with reference to production of hydroxide ions in the cathode electrolyte, can be configured to produce bicarbonate ions and/or carbonate ions in the first cathode electrolyte by dissolving carbon dioxide in the first cathode electrolyte and applying a voltage of less than 3V, or less than 2.5 V, or less than 2V, or less than 1.5V such as less than 1.0V, or even less than 0.8 V or 0.6V across the cathode and anode.

**[0087]** In some embodiments, hydroxide ions and/or carbonate ions and/or bicarbonate ions produced in the cathode electrolyte, and hydrochloric acid produced in the anode electrolyte are removed from the system, while sodium chloride in the salt solution electrolyte is replenished to maintain continuous operation of the system. In some embodiments, the system can be configured to operate in various production modes including batch mode, semi-batch mode, continuous flow mode, with or without the option to withdraw portions of the hydroxide solution produced in the cathode electrolyte, or withdraw all or a portions of the acid produced in the anode electrolyte, or direct the hydrogen gas produced at the cathode to the anode where it may be oxidized.

**[0088]** In some embodiments, hydroxide ions and/or bicarbonate ions and/or carbonate ion solutions are produced in the cathode electrolyte when the voltage applied across the anode and cathode is less than 3V, 2.9V or less, 2.8V or less, 2.7V or less, 2.6V or less, 2.5V or less, 2.4V or less, 2.3V or less, 2.2V

or less, 2.1V or less, 2.0V or less, 1.9V or less, 1.8V or less, 1.7V or less, 1.6V, or less 1.5V or less, 1.4V or less, 1.3V or less, 1.2V or less, 1.1V or less, 1.0V or less, 0.9V or less or less, 0.8V or less, 0.7V or less, 0.6V or less, 0.5V or less, 0.4V or less, 0.3V or less, 0.2V or less, or 0.1 V or less.

**[0089]** In another embodiment, the voltage across the anode and cathode can be adjusted such that gas will form at the anode, e.g., oxygen or chlorine, while hydroxide ions, carbonate ions and bicarbonate ions are produced in the cathode electrolyte and hydrogen gas is generated at the cathode. However, in this embodiment, hydrogen gas is not supplied to the anode. As can be appreciated by one ordinarily skilled in the art, in this embodiment, the voltage across the anode and cathode will be generally higher compared to the embodiment when a gas does not form at the anode.

**[0090]** With reference to FIGS. 1-2, in some embodiments, the invention provides for a system comprising one or more anion exchange membrane 120, and cation exchange membranes 116, 122 located between the gas diffusion anode 102 and the cathode 106. In some embodiments, the membranes should be selected such that they can function in an acidic and/or basic electrolytic solution as appropriate. Other desirable characteristics of the membranes include high ion selectivity, low ionic resistance, high burst strength, and high stability in an acidic electrolytic solution in a temperature range of  $0^\circ\text{C}$ . to  $100^\circ\text{C}$ . or higher, or an alkaline solution in similar temperature range may be used. In some embodiments, a membrane that is stable in the range of  $0^\circ\text{C}$ . to  $80^\circ\text{C}$ ., or  $0^\circ\text{C}$ . to  $90^\circ\text{C}$ ., but not stable above these ranges may be used. For other embodiments, it may be useful to utilize an ion-specific ion exchange membranes that allows migration of one type of cation but not another; or migration of one type of anion and not another, to achieve a desired product or products in an electrolyte. In some embodiments, the membrane should be stable and functional for a desirable length of time in the system, e.g., several days, weeks or months or years at temperatures in the range of  $0^\circ\text{C}$ . to  $80^\circ\text{C}$ ., or  $0^\circ\text{C}$ . to  $90^\circ\text{C}$ . and higher and/or lower. In some embodiments, for example, the membranes should be stable and functional for at least 5 days, 10 days, 15 days, 20 days, 100 days, 1000 days or more in electrolyte temperatures at  $80^\circ\text{C}$ .,  $70^\circ\text{C}$ .,  $60^\circ\text{C}$ .,  $50^\circ\text{C}$ .,  $40^\circ\text{C}$ .,  $30^\circ\text{C}$ .,  $20^\circ\text{C}$ .,  $10^\circ\text{C}$ .,  $5^\circ\text{C}$ . and more or less.

**[0091]** The ohmic resistance of the membranes will affect the voltage drop across the anode and cathode, e.g., as the ohmic resistance of the membranes increase, the voltage drop across the anode and cathode will increase, and vice versa. Membranes currently available can be used and they include membranes with relatively low ohmic resistance and relatively high ionic mobility; similarly, membranes currently available with relatively high hydration characteristics that increase with temperatures, and thus decreasing the ohmic resistance can be used. Consequently, as can be appreciated, by selecting currently available membranes with lower ohmic resistance, the voltage drop across the anode and cathode at a specified temperature can be lowered.

**[0092]** Scattered through currently available membrane are ionic channels consisting of acid groups. These ionic channels may extend from the internal surface of the matrix to the external surface and the acid groups may readily bind water in a reversible reaction as water-of-hydration. This binding of water as water-of-hydration follows first order reaction kinetics, such that the rate of reaction is proportional to temperature. Consequently, currently available membranes can be selected to provide a relatively low ohmic and ionic resistance

while providing for improved strength and resistance in the system for a range of operating temperatures. Suitable membranes are commercially available from Asahi Kasei of Tokyo, Japan; or from Membrane International of Glen Rock, N.J., and USA.

[0093] In some embodiments, the cathode electrolyte **108**, **108A**, **108B** is operatively connected to a waste gas treatment system (not illustrated) where the alkaline solution produced in the cathode electrolyte is utilized, e.g., to sequester carbon dioxide contained in the waste gas by contacting the waste gas and the cathode electrolyte with a solution of divalent cations to precipitate hydroxides, carbonates and/or bicarbonates as described in commonly assigned U.S. patent application Ser. No. 12/344,019 filed on Dec. 24, 2008, herein incorporated by reference in its entirety. The precipitates, comprising, e.g., calcium and magnesium hydroxides, carbonates and bicarbonates in some embodiments may be utilized as building materials, e.g., as cements and aggregates, as described in commonly assigned U.S. patent application Ser. No. 12/126,776 filed on May 23, 2008, supra, herein incorporated by reference in its entirety. In some embodiments, some or all of the carbonates and/or bicarbonates are allowed to remain in an aqueous medium, e.g., a slurry or a suspension, and are disposed of in an aqueous medium, e.g., in the ocean depths or a subterranean site.

[0094] In some embodiments, the cathode and anode are also operatively connected to an off-peak electrical power-supply system **114** that supplies off-peak voltage to the electrodes. Since the cost of off-peak power is lower than the cost of power supplied during peak power-supply times, the system can utilize off-peak power to produce an alkaline solution in the cathode electrolyte at a relatively lower cost.

[0095] In another embodiment, the system produces an acid, e.g., hydrochloric acid **124** in the anode electrolyte **104**. In some embodiments, the anode compartment is operably connected to a system for dissolving minerals and/or waste materials comprising divalent cations to produce a solution of divalent cations, e.g., Ca<sup>++</sup> and Mg<sup>++</sup>. In some embodiments, the divalent cation solution is utilized to precipitate hydroxides, carbonates and/or bicarbonates by contacting the divalent cation solution with the present alkaline solution and a source of carbon dioxide gas as described in U.S. patent application Ser. No. 12/344,019 filed on Dec. 24, 2008, supra, herein incorporated by reference in its entirety. In some embodiments, the precipitates are used as building materials e.g., cement and aggregates as described in commonly assigned U.S. patent application Ser. No. 12/126,776, supra, herein incorporated by reference in its entirety.

[0096] With reference to FIG. 1, on applying a voltage across the anode **102** and cathode **106**, protons will form at the anode from oxidation of hydrogen gas supplied to the anode, while hydroxide ions and hydrogen gas will form at the cathode electrolyte from the reduction of water, as follows:



[0097] Since protons are formed at the anode from hydrogen gas provided to the anode; and since a gas such as oxygen does not form at the anode; and since water in the cathode electrolyte is reduced to hydroxide ions and hydrogen gas at the cathode, the system will produce hydroxide ions in the cathode electrolyte and protons in the anode electrolyte when a voltage is applied across the anode and cathode. Further, as

can be appreciated, in the present system since a gas does not form at the anode, the system will produce hydroxide ions in the cathode electrolyte and hydrogen gas at the cathode and hydrogen ions at the anode when less than 2V is applied across the anode and cathode, in contrast to the higher voltage that is required when a gas is generated at the anode, e.g., chlorine or oxygen. For example, in some embodiments, hydroxide ions are produced when less than 2.0V, 1.5V, 1.4V, 1.3V, 1.2V, 1.1V, 1.0V, 0.9V, 0.8V, 0.7V, 0.6V, 0.5V, 0.4V, 0.3V, 0.2V, 0.1 V or less is applied across the anode and cathode.

[0098] As discussed above, in the system, on applying a voltage across the anode **102** and cathode **106**, the positively charged protons formed at the anode will attempt to migrate to the cathode through the anode electrolyte **104**, while the negatively charged hydroxide ions formed at the cathode will attempt to migrate to the anode through the cathode electrolyte **108**, **108A**, **108B**. As is illustrated in FIG. 1 and with reference to hydroxide ions in the cathode electrolyte **108**, **108A**, **108B**, since the first cation exchange membrane **116** will restrict the migration of anions from the cathode electrolyte **108**, **108A**, **108B**, and since the anion exchange membrane **120** will prevent the migration of anions from the anode electrolyte **104** to the salt solution **118**, the hydroxide ions generated in the cathode electrolyte will be prevented from migrating out of the cathode electrolyte through the cation exchange membrane. Consequently, on applying the voltage across the anode and cathode, the hydroxide ions produced at the cathode will be contained in the cathode electrolyte. Thus, depending on the flow rate of fluids into and out of the cathode electrolyte and the rate of carbon dioxide dissolution in the cathode electrolyte, the pH of the cathode electrolyte will adjust, e.g., the pH may increase, decrease or remain the same.

[0099] In some embodiments, depending on the ionic species desired in cathode electrolyte **108**, **108A**, **108B** and/or the anode electrolyte **104** and/or the salt solution **118**, alternative reactants can be utilized. Thus, for example, if a potassium salt such as potassium hydroxide or potassium carbonate is desired in the cathode electrolyte **108**, **108A**, **108B**, then a potassium salt such as potassium chloride can be utilized in the salt solution **118**. Similarly, if sulfuric acid is desired in the anode electrolyte, then a sulfate such as sodium sulfate can be utilized in the salt solution **118**. As described in some embodiments herein, carbon dioxide gas is absorbed in the cathode electrolyte; however, it will be appreciated that other gases, including volatile vapors, can be absorbed in the electrolyte, e.g., sulfur dioxide, or organic vapors to produce a desired result. The gas can be added to the electrolyte in various ways, e.g., by bubbling it directly into the electrolyte, or dissolving the gas in a separate compartment connected to the cathode compartment and then directed to the cathode electrolyte as described herein.

[0100] With reference to FIGS. 1 and 3, method **300** in some embodiments comprises a step **302** of applying a voltage across a cathode **106** and a gas diffusion anode **102** in an electrochemical system **100**, wherein the cathode contacts a cathode electrolyte comprising dissolved carbon dioxide. In some embodiments, the method includes a step of providing hydrogen to the gas diffusion anode **102**; a step of contacting the cathode **106** with a cathode electrolyte **108**, **108A**, **108B** comprising dissolved carbon dioxide gas **107A**; and a step of applying a voltage **114** across the anode and cathode; a step whereby protons are produced at the anode and hydroxide



ions and hydrogen gas produced at the cathode; a step whereby a gas is not produced at the anode when the voltage is applied across the anode and cathode; a step wherein the voltage applied across the anode and cathode is less than 2V; a step comprising directing hydrogen gas from the cathode to the anode; a step comprising whereby protons are migrated from the anode to an anode electrolyte; a step comprising interposing an anion exchange membrane between the anode electrolyte and the salt solution; a step comprising interposing a first cation exchange membrane between the cathode electrolyte and the salt solution, wherein the salt solution is contained between the anion exchange membrane and the first cation exchange membrane; a step comprising whereby anions migrate from the salt solution to the anode electrolyte through the anion exchange membrane, and cations migrate from the salt solution to the cathode electrolyte through the first cation exchange membrane; a step comprising producing hydroxide ions and/or carbonate ions and/or bicarbonate ions in the cathode electrolyte; a step comprising producing an acid in the anode electrolyte; a step comprising producing sodium hydroxide and/or sodium carbonate and/or sodium bicarbonate in the cathode electrolyte; a step whereby hydrochloric acid is produced in the anode electrolyte; a step comprising contacting the cathode electrolyte with a divalent cation solution, wherein the divalent cations comprise calcium and magnesium ions; a step comprising producing partially desalinated water from the salt solution; a step comprising withdrawing a first portion of the cathode electrolyte and contacting the first portion of cathode electrolyte with carbon dioxide; and a step comprising contacting the first portion of cathode electrolyte with a divalent cation solution.

[0101] In some embodiments, hydroxide ions are formed at the cathode 106 and in the cathode electrolyte 108, 108A, 108B by applying a voltage of less than 2V across the anode and cathode without forming a gas at the anode, while providing hydrogen gas at the anode for oxidation at the anode. In some embodiments, method 300 does not form a gas at the anode when the voltage applied across the anode and cathode is less than 3V or less, 2.9V or less, 2.8V or less, 2.7V or less, 2.6V or less, 2.5V or less, 2.4V or less, 2.3V or less, 2.2V or less, 2.1V or less, 2.0V or less, 1.9V or less, 1.8V or less, 1.7V or less, 1.6V or less, 1.5V or less, 1.4V or less, 1.3V or less, 1.2V or less, 1.1V or less, 1.0V or less, 0.9V or less, 0.8V or less, 0.7V or less, 0.6V or less, 0.5V or less, 0.4V or less, 0.3V or less, 0.2V or less, or 0.1 V or less, while hydrogen gas is provided to the anode where it is oxidized to protons. As will be appreciated by one ordinarily skilled in the art, by not forming a gas at the anode and by providing hydrogen gas to the anode for oxidation at the anode, and by otherwise controlling the resistance in the system for example by decreasing the electrolyte path lengths and by selecting ionic membranes with low resistance and any other method known in the art, hydroxide ions can be produced in the cathode electrolyte with the present lower voltages.

[0102] In some embodiments, hydroxide ions, bicarbonate ions and carbonate ions are produced in the cathode electrolyte where the voltage applied across the anode and cathode is less than 3.0V, 2.9V, 2.8V, 2.7V, 2.6V, 2.5V, 2.4V, 2.3V, 2.2V, 2.1V, 2.0V, 1.9V, 1.8V, 1.7V, 1.6V, 1.5V, 1.4V, 1.3V, 1.2V, 1.1V, 1.0V, 0.9V, 0.8V, 0.7V, 0.6V, 0.5V, 0.4V, 0.3V, 0.2V, 0.1V or less without forming a gas at the anode. In some embodiments, the method is adapted to withdraw and replenish at least a portion of the cathode electrolyte and the acid in

the anode electrolyte back into the system in either a batch, semi-batch or continuous mode of operation.

[0103] With reference to FIGS. 7-9, in one embodiment, the system 700 comprises a cathode 106 in contact with a cathode electrolyte 108 comprising added carbon dioxide 107, wherein the cathode electrolyte is separated from an anode electrolyte 104 by first cation exchange membrane 116. In an embodiment as is illustrated in FIG. 8, the system 800 comprises an anode 102 that is separated from the anode electrolyte by a second cation exchange membrane 122 that is in contact with the anode 102.

[0104] In systems 700, 800, 900 as illustrated in FIGS. 7-9, the first cation exchange membrane 116 is located between the cathode 106 and anode 102 such it separates the cathode electrolyte 108 from the anode electrolyte 104. Thus as is illustrated in FIGS. 7-9, on applying a relatively low voltage, e.g., less than 2V or less than 1V, across the anode 102 and cathode 106, hydroxide ions ( $\text{OH}^-$ ) and hydrogen gas ( $\text{H}_2$ ) are produced at the cathode 106, and hydrogen gas is oxidized at the anode 102 to produce hydrogen ions at the anode 102, without producing a gas at the anode. In certain embodiments, the hydrogen gas produced at the cathode is directed to the anode through a hydrogen gas delivery system 112, and is oxidized to hydrogen ions at the anode. In various embodiments, utilizing hydrogen gas at the anode from hydrogen generated at the cathode, eliminates the need for an external supply of hydrogen; consequently, the utilization of energy by the system to produce the alkaline solution is reduced.

[0105] In certain embodiments as illustrated in FIGS. 7-9, under the applied voltage 114 across the anode 102 and cathode 106, hydroxide ions are produced at the cathode 106 and migrate into the cathode electrolyte 108, and hydrogen gas is produced at the cathode. In certain embodiments, the hydrogen gas produced at the cathode 106 is collected and directed to the anode, e.g., by a hydrogen gas delivery system 122, where it is oxidized to produce hydrogen ions at the anode. Also, as illustrated in FIGS. 7-9, under the applied voltage 114 across the anode 102 and cathode 106, hydrogen ions produced at the anode 102 migrate from the anode 102 into the anode electrolyte 104 to produce an acid, e.g., hydrochloric acid.

[0106] In certain embodiments, the first cation exchange membrane 116 is selected to allow passage of cations therethrough while restricting passage of anions therethrough. Thus, as is illustrated in FIGS. 7-9, on applying the low voltage across the anode 102 and cathode 106, cations in the anode electrolyte 104, e.g., sodium ions in the anode electrolyte comprising sodium chloride, migrate into the cathode electrolyte through the first cation exchange membrane 116, while anions in the cathode electrolyte 108, e.g., hydroxide ions, and/or carbonate ions, and/or bicarbonate ions, are prevented from migrating from the cathode electrolyte through the first cation exchange membrane 116 and into the anode electrolyte 104.

[0107] As is illustrated in FIGS. 7-9, where the anode electrolyte 104 comprises an aqueous salt solution such as sodium chloride in water, a solution, e.g., and alkaline solution, is produced in the cathode electrolyte 108 comprising cations, e.g., sodium ions, that migrate from the anode electrolyte 104, and anions, e.g., hydroxide ions produced at the cathode 106, and/or carbonate ions and/or bicarbonate ions produced by dissolving carbon dioxide 107 in the cathode electrolyte.

[0108] Concurrently, in the anode electrolyte 104, an acid, e.g., hydrochloric acid is produced from hydrogen ions

migrating from the anode **102** and anions, e.g., chloride ions, present from the anode electrolyte.

[0109] With reference to FIG. **8**, an anode comprising a second cation exchange membrane **122** is utilized to separate the anode **102** from the anode electrolyte **104** such that on a first surface, the cation exchange membrane **122** is in contact with the anode **102**, and on an opposed second surface it is in contact with the anode electrode electrolyte **104**. Thus, as can be appreciated, in this embodiment, since the second cation exchange membrane is permeable to cations, e.g., hydrogen ions, the anode is in electrical contact with the anode electrolyte through the second cation exchange membrane. In some embodiments, the anode as illustrated in FIG. **8** may comprise a gas diffusion anode as described below.

[0110] In the embodiment of FIG. **8**, as with the embodiment illustrated in FIG. **7**, on applying the low voltage across the anode **102** and cathode **106**, hydrogen ions produced at the anode **102** from oxidation of hydrogen gas at the anode migrate through the second cation exchange membrane **122** into the anode electrolyte **104**. At the same time, cations in the anode electrolyte, e.g., sodium ions in the anode electrolyte comprising sodium chloride, migrate from the anode electrolyte **104** into the cathode electrolyte **108** through the first cation exchange membrane **116**, while anions in the cathode electrolyte **108**, e.g., hydroxide ions, and/or carbonate ions, and/or bicarbonate ions, are prevented from migrating from the cathode electrolyte **108** to the anode electrolyte **104** through the first cation exchange membrane **116**.

[0111] Also as illustrated in FIG. **8**, hydrogen ions migrating from the anode **102** through the second cation exchange membrane **122** into the anode electrolyte **104** will produce an acid, e.g., hydrochloric acid with the cations, e.g., chloride ions, present in the anode electrolyte; and in the cathode electrolyte **108**, an alkaline solution is produced from cations present in the cathode electrolyte and anions, e.g., sodium ions, that migrate from the anode to the cathode electrolyte through the first cation exchange membrane **116**.

[0112] In some embodiments, cation exchange membranes **116** and **122** are conventional and are available from, for example, Asahi Kasei of Tokyo, Japan; or from Membrane International of Glen Rock, N.J., or DuPont, in the USA. However, it will be appreciated that in some embodiments, depending on the need to restrict or allow migration of a specific cation or an anion species between the electrolytes, a cation exchange membrane that is more restrictive and thus allows migration of one species of cations while restricting the migration of another species of cations may be used as, e.g., a cation exchange membrane that allows migration of sodium ions into the cathode electrolyte from the anode electrolyte while restricting migration of hydrogen ions from the anode electrolyte into the cathode electrolyte, may be used. Such restrictive cation exchange membranes are commercially available and can be selected by one ordinarily skilled in the art.

[0113] As is illustrated in FIG. **8**, the anode **102** comprises a second cation exchange membrane **112** that separates the anode **102** from the anode electrolyte **104** and is attached to the anode. Thus, in some embodiments, the anode and second cation exchange membrane may comprise an integral gas diffusion anode that is commercially available, or can be fabricated as described for example in co-pending and commonly assigned U.S. Provisional Patent Application No. 61/151,484, titled "Electro-catalyst Electrodes for Low-voltage electrochemical Hydroxide System", filed Feb. 10, 2009,

herein fully incorporated by reference. However, as can be appreciated by one ordinarily skilled in the art, notwithstanding that a gas diffusion anode is illustrated and utilized in FIGS. **7** and **8** and described herein, in the some embodiments, any conventional anode that can be configured to oxidize hydrogen gas to produce hydrogen ions as described herein can be utilized.

[0114] With reference to FIGS. **1-9** in some embodiments, the cathode electrolyte **108** is operatively connected to a supply of carbon dioxide gas **107**, contained, e.g., in an industrial plant, e.g., a power generating plant, a cement plant, or an ore smelting plant. If necessary, this source of carbon dioxide comprises a gas wherein the concentration of carbon dioxide is greater than the concentration of carbon dioxide in the ambient atmosphere. This source of carbon dioxide may also contain other gaseous and non-gaseous components of a combustion process, e.g., nitrogen gas,  $\text{SO}_x$ ,  $\text{NO}_x$ , as described in co-pending and commonly assigned U.S. Provisional Patent application No. 61/223,657, titled "Gas, Liquids, Solids Contacting Methods and Apparatus", filed Jul. 7, 2009 herein fully incorporated by reference. However, as can be appreciated, this source of carbon dioxide can be cleaned and utilized as the carbon dioxide added to the cathode electrolyte **108**.

[0115] Although carbon dioxide is present in ordinary ambient air, partly due to the very low concentration in air, ambient carbon dioxide may not provide sufficient carbon dioxide to achieve the results obtained with the present system and method that utilize carbon dioxide taken from an industrial waste gas stream, e.g., from the stack gases of a fossil fuelled power generating plant or a cement production plant. Also, in some embodiments of the system and method, since the cathode electrolyte is contained in a closed system wherein the pressure of the added carbon dioxide gas within the system is greater than the ambient atmospheric pressure, ambient air and hence ambient carbon dioxide is typically prevented from infiltrating into the cathode electrolyte.

[0116] In some embodiments, and with reference to FIGS. **1-9**, carbon dioxide is added to the cathode electrolyte to dissolve and produce carbonic acid that dissociates to hydrogen ions and carbonate ions and/or bicarbonate ions, depending on the pH of the cathode electrolyte. Concurrently, as described above, hydroxide ions, produced from reducing water in the cathode electrolyte, may react with the hydrogen ions to produce water in the cathode electrolyte. Thus, depending on the degree of alkalinity desired in the cathode electrolyte, the pH of the cathode electrolyte may be adjusted and in some embodiments is maintained between and 7 and 14 or greater; or between 7 and 9; or between 8 and 11 as is well understood in the art, and as illustrated in carbonate speciation diagram of FIG. **5**. In some embodiments, the pH of the cathode electrolyte may be adjusted to any value between 7 and 14 or greater, including a pH 7.0, 7.5, 8.0, 8.5, 9.0, 9.5, 10.0, 10.5, 11.0, 11.5, 12.0, 12.5, 13.0, 13.5, 14.0 and greater.

[0117] Similarly, in some embodiments of the system, the pH of the anode electrolyte is adjusted and is maintained between less than 0 and up to 7 and/or between less than 0 and up to 4, by regulating the concentration of hydrogen ions that migrate into the anode electrolyte from oxidation of hydrogen gas at the anode, and/or the withdrawal and replenishment of anode electrolyte in the system. In this regard and as can be appreciated by one ordinarily skilled in the art and with reference to FIG. **6**, since the voltage across the anode and cathode is dependent on several factors including the differ-

ence in pH between the anode electrolyte and the cathode electrolyte as can be determined by the Nerst equation, in some embodiments, the pH of the anode electrolyte is adjusted to a value between 0 and 7, including 0, 0.5, 1.0, 1.5, 2.0, 2.5, 3.0, 3.5, 4.0, 4.5, 5.0, 5.5, 6.0, 6.5 and 7, depending on the desired operating voltage across the anode and cathode. Thus, as can be appreciated, in equivalent systems, where it is desired to reduce the energy used and/or the voltage across the anode and cathode, e.g., as in the Chloralkali process, carbon dioxide can be added to the electrolyte as disclosed herein to achieve a desired pH difference between the anode electrolyte and cathode electrolyte. Thus, to the extent that such systems utilize carbon dioxide, these equivalent systems are within the scope of the present invention.

[0118] With reference to FIGS. 1-15, in some embodiments, the anode electrolyte 102 comprises a salt solution, e.g., a terrestrial brine, that includes sodium ions and chloride ions; the system is configured to produce the alkaline solution in the cathode electrolyte 108 while also producing hydrogen ions at the anode 106, with less than 1V across the anode 122 and cathode 106, without producing a gas at the anode; the system is configured to migrate hydrogen ions from the anode into the anode electrolyte; the anode electrolyte comprises an acid; the system is configured to produce bicarbonate ions and/or carbonate ions in the cathode electrolyte 108; migrate hydroxide ions from the cathode 106 into the cathode electrolyte; migrate cations, e.g., sodium ions, from the anode electrolyte 104 into the cathode electrolyte through the first cation exchange membrane 116; hydrogen gas is provided to the anode; and a hydrogen gas delivery system 112 is configured to direct hydrogen gas from the cathode to the anode.

[0119] With reference to FIGS. 1-15, in some embodiments the cathode electrolyte 108 may be operatively connected to a system for further processing of the cathode electrolyte, e.g., a carbonate and/or bicarbonate precipitating system comprising a precipitator configured to precipitate carbonates and/or bicarbonates from a solution, wherein in some embodiments the carbonates and/or bicarbonates comprise calcium and/or magnesium carbonate and/or bicarbonate. Also, in some embodiments, the anode electrolyte 104 comprising an acid, e.g., hydrochloric acid, and a depleted salt solution comprising low amount sodium ions, is operatively connected to a system for further processing of an acid, e.g., a mineral dissolution system that is configured to dissolve minerals and produce a mineral solution comprising calcium ions and/or magnesium ions, e.g., mafic minerals such as olivine and serpentine. In some embodiments, not shown in FIG. 8, the acid may be used for other purposes in addition to or instead of mineral dissolution. Such use includes use as a reactant in production of cellulosic biofuels, use in the production of polyvinyl chloride (PVC), and the like. System appropriate to such uses may be operatively connected to the electrochemistry unit, or the acid may be transported to the appropriate site for use.

[0120] In the embodiments, the mineral dissolution system is operatively connected to nano-filtration system that is configured to separate sodium ions and chloride ions from the mineral solution comprising, e.g., calcium ions, magnesium ions, silica, hydrochloric acid and/or sodium hydroxide. In some embodiments, the nano-filtration system is configured with a reverse osmosis system that is capable of concentrating sodium ions and chloride ions into a salt solution that is used as the anode electrolyte.

[0121] With reference to FIGS. 1-15 the method in some embodiments comprises a step of adding carbon dioxide into a cathode electrolyte 108 in contact with a cathode 106 wherein the cathode electrolyte is separated from an anode electrolyte 104 by a first cation exchange membrane 116; and producing an alkaline solution in the cathode electrolyte by applying a voltage 114 of less than 1V across the cathode 106 and an anode 102 in contact with the anode electrolyte without producing a gas at the anode.

[0122] In some embodiments of the method, the anode 102 is in contact with a second cation exchange membrane 122 that separates the anode from the anode electrolyte; the alkaline solution 108 comprises hydroxide ions and/or bicarbonate ions and/or carbonate ions; the carbon dioxide 107 is contained in wastes gases of an industrial plant, e.g., an electrical power generating plant, a cement production plant, a fermentation process or an ore processing facility.

[0123] In some embodiments, ambient air is excluded the cathode electrolyte 108; a pH of between 7 and 14 or greater is maintained in the cathode electrolyte; a pH of between 7 and 9 is maintained in the cathode electrolyte; a pH of between 8 and 11 is maintained in the cathode electrolyte; a pH of from less than 0 and up to 7 is maintained in the anode electrolyte; a pH of from less than 0 and up to 4 is maintained in the anode electrolyte; hydrogen gas is oxidized at the anode 102 to produce hydrogen ions and hydrogen ions are migrated from the anode through the second cation exchange membrane 122 into the anode electrolyte; hydroxide ions and hydrogen gas are produced at the cathode 106; hydroxide ions are migrated from the cathode 106 into the cathode electrolyte 108; hydrogen gas is directed from the cathode 106 to the anode 102; cations ions are migrated from the anode electrolyte 104 through the first cation exchange membrane 122 into the cathode electrolyte 108 wherein the cations comprise sodium ions.

[0124] In some embodiments, the method comprises producing sodium hydroxide and/or sodium carbonate ions and/or sodium bicarbonate ions in the cathode electrolyte 108; producing an acid and a depleted salt solution in the anode electrolyte 104 comprising sodium ions and chloride ions; utilizing the anode electrolyte to dissolve minerals and produce a mineral solution comprising calcium ions and/or magnesium ions, wherein the minerals comprises mafic minerals; filtering the mineral solution to produce a filtrate comprising sodium ions and chloride ions; concentrating the filtrate to produce the salt solution, wherein the concentrator comprises a reverse osmosis system; utilizing the salt solution as the anode electrolyte 104; precipitating a carbonate and/or bicarbonate with the cathode electrolyte; wherein the carbonate and/or bicarbonate comprises calcium and/or magnesium carbonate and/or bicarbonate. In some embodiments, the method includes disposing of the acid in an underground storage site where the acid can be stored in an un-reactive salt or rock formation without environmental acidification.

[0125] With reference to FIGS. 1-15, the method in another embodiment comprises a step of producing an acid in an electrochemical system, e.g., system 800, comprising added carbon dioxide 106A, 107 in the cathode electrolyte 108; and contacting a mineral 906 with the acid 124. In some embodiment the method further producing the acid in the anode electrolyte 104, without generating a gas at the anode 102, and oxidizing hydrogen gas 112 at the anode, wherein the acid comprises hydrochloric acid 124; and wherein the hydrogen gas 112 is produced at the cathode 106; producing

an alkaline solution in the cathode electrolyte **108**; migrating sodium ions into the cathode electrolyte; wherein the alkaline solution comprises sodium hydroxide, sodium bicarbonate and/or sodium carbonate; wherein the voltage is less than 2 V or less than 1 V; wherein the anode electrolyte **104** is separated from the cathode electrolyte **108** by first cation exchange membrane **116**; wherein the anode **102** comprises a second cation exchange membrane **122** in contact with the anode electrolyte **102**; wherein the anode electrolyte comprises a salt, e.g., sodium chloride; dissolving a mineral **906** with the acid **124** to produce a mineral solution; producing calcium ions and/or magnesium ions; wherein the mineral comprises a mafic mineral, e.g. olivine or serpentine; filtering the mineral solution to produce a filtrate comprising sodium ions and chloride ions solution; concentrating the filtrate to produce a salt solution; utilizing the salt solution as the anode electrolyte **104**; precipitating a carbonate and/or bicarbonate with the cathode electrolyte; wherein the carbonate and/or bicarbonate comprises calcium and/or magnesium carbonate and/or bicarbonate. In some embodiments, the method includes disposing of the acid in an underground storage site where the acid can be stored in an un-reactive salt or rock formation and hence does not an environmental acidification.

[0126] With reference to FIGS. 1-15, the system and method produce an alkaline solution **108** and an acid **124** by a redox reaction utilizing a salt solution **130** and water **902**. A suitable salt solution includes a synthetic saltwater, e.g., a sodium chloride solution made by dissolving sodium chloride salt in water; or a naturally occurring saltwater, e.g., brine **904**.

[0127] In an embodiment of the system as illustrated in FIGS. 9-15, the system comprises an anode **122**, e.g., a hydrogen-oxidizing anode in communication with a cathode electrolyte **108** comprising bicarbonate ions; and a brine production system **904** configured to provide cations, e.g.,  $\text{Na}^+$ , to the cathode electrolyte **108**. In another embodiment, the system comprises an anode, e.g., an electrochemistry unit **100**, **400**, **700**, **800** comprising hydrogen-oxidizing anode **122** in communication with a cathode electrolyte **108** in a cathode compartment **144** wherein the electrochemistry unit is operably connected to a carbon sequestration system (not illustrated) configured to sequester carbon dioxide **106 A**, **107**, **107A** with the cathode electrolyte **108**. In some embodiment of the system, the brine production system **904** comprises subterranean brines; in some embodiments, the cathode electrolyte **108** comprises added carbon dioxide **107**.

[0128] In some embodiments of the system, the cathode electrolyte comprises hydroxide ions, bicarbonate ions and/or carbonate ions; ion exchange membranes, e.g., cation exchange membrane **116**, **122** and anion exchange membrane **120** configured to separate cations and anions from the salt **130**, e.g., brine, to produce an ion-depleted salt **124**, e.g., ion-depleted brine **125**. In some embodiments, the cations comprises sodium ions; in some embodiments, the system is configured to produce hydrogen gas **112** and hydroxide ions at the cathode **106** in contact with the cathode electrolyte **108** and oxidize hydrogen to protons at the anode **122** in contact with the anode electrolyte **104** without producing a gas at the anode, when a voltage **114** is applied across the anode and cathode. In some embodiments, the voltage is less than 3V. In some embodiments, the system is configured to produce an acid **124**, e.g., HCl in the anode electrolyte.

[0129] In some embodiments, the system comprises an acid dissolution system (not illustrated) configured to produce

divalent cations with the acid; in some embodiments, the divalent cations comprise calcium ions and/or magnesium ions.

[0130] In some embodiments, the system comprises a carbon sequestration system (not illustrated) configured to sequester carbon dioxide with the cathode electrolyte **108**. In some embodiments, carbon dioxide is contained in an industrial waste gas is used; in some embodiments the carbon dioxide is sequestered as carbonate and/or bicarbonate, e.g., carbonate and/or bicarbonate comprising divalent cations.

[0131] In some embodiments as illustrated in FIGS. 9-15, the system comprises a water treatment system **902**, **1000**, **1100**, **1200**, **1300**, **1400**, **1500** configured for several uses, e.g., to dilute a solution, e.g., the brine **130**, the acid **104**, the cathode electrolyte **108** or the anode electrolyte **104**. In some embodiments, the water treatment system is also configured to adjust the pH of the electrolytes the acid, the electrolytes and the brine.

[0132] As is illustrated in FIGS. 11 and 12, the water treatment system includes one or more of the following unit processes and equipment: a sedimentation or screen filter; an activation carbon filter; a reverse osmosis system; an ultra-filtration system; a UV lamp; a chlorination process; a hardness remover; a pH adjustment system; a flocculation system; an electro-dialysis system. Such unit process may be conventionally; however, for some applications, e.g., preparing the electrolytes, a customized unit or process may be required as is know in the art.

[0133] Also as illustrated in FIGS. 9-15, the system includes a brine production and treatment system **904** comprising, in some embodiments, a brine storage system; a brine saturation system; and a brine secondary purification system. Such brine production and treatment system includes a conventional brine treatment system or and/or brine treatment system customized for the present alkali production system and method.

[0134] In some embodiments, the system include a desalination system (not illustrated) configured to produce desalinated water from the ion-depleted brine **125**. In some embodiments, the desalinated water is operatively connected to the water treatment system.

[0135] With reference to FIGS. 1-15, the method in various embodiments comprise a step of oxidizing hydrogen to protons at a hydrogen-oxidizing anode **122** in communication with a cathode electrolyte **108** comprising bicarbonate ions; and a step of providing cations from a brine **130** to the cathode electrolyte **108**. In another embodiments, the method comprises oxidizing hydrogen to protons at a hydrogen-oxidizing anode **122** in communication with a cathode electrolyte **108**; and sequestering carbon dioxide with the cathode electrolyte **108**.

[0136] In various embodiments, the method include a step of using a brine comprising subterranean brines comprising sodium ions; a step of adding carbon dioxide to the cathode electrolyte; a step of producing hydrogen gas and hydroxide ions at a cathode in contact with the cathode electrolyte without producing a gas at the anode, by applying a voltage across the anode and cathode; a step of applying a voltage is less than 3V across the anode and cathode.

[0137] In some embodiments the method includes a step of producing hydroxide ions and/or carbonate ions and/or bicarbonate ions in the cathode electrolyte; a step of separating cations and anions from the brines to produce an ion-depleted brine; a step of producing an acid in the anode electrolyte,

e.g., hydrochloric acid; a step of configuring the acid in an acid dissolution system to dissolve material and produce divalent cations, including divalent cations comprise calcium ions and/or magnesium ions; a step of configuring a carbon sequestration system to sequester carbon dioxide with the cathode electrolyte, wherein the carbon dioxide is contained, e.g., in an industrial waste gas, and wherein the carbon dioxide is sequestered as carbonate and/or bicarbonate, e.g., divalent cation carbonates; a step of utilizing a water treatment system to dilute the cathode/anode electrolytes, the salt, e.g., the brine, and the acid.

**[0138]** In some embodiments the method includes a step of generating hydrogen gas and hydroxide ions by reducing water at the cathode; a step of adjusting the pH of the cathode/anode electrolytes, brine and acid with the water; a step of adjusting the ionic concentration in the anode/cathode electrolytes, brine and acid with the water; a step of producing desalinated water from the ion-depleted brine; a step of circulating the desalinated water for further treatment in the water treatment system.

**[0139]** In an exemplary embodiment, a system configured substantially as illustrated in FIGS. 1-15 was operated with a constant current density applied across the electrodes at steady state conditions while carbon dioxide gas was continuously dissolved into the cathode electrolyte, at various temperatures and voltages. In the system, a platinum catalyst, gas diffusion anode obtained from E-TEK Corporation, (USA) was used as the anode. A Raney nickel deposited onto a nickel gauze substrate was used as the cathode. In the system, the initial acid concentration in the anode electrolyte was 1 M; the initial sodium chloride salt solution was 5 M; and the initial concentration of the sodium hydroxide solution in the cathode compartment was 1 M. In the system, the pH of the cathode compartment was maintained at either 8 or 10 by regulating the amount of carbon dioxide dissolved in the cathode electrolyte.

TABLE 1

Experimental Current Density, Temperature and Voltage Characteristics of the System			
T (° C.)	Potential (V)	pH	Current density (mA/cm <sup>2</sup> )
25	0.8	10	8.6
		8	11.2
	1.2	10	28.3
		8	29.2
	1.6	10	50.2
		8	50.6
75	0.8	10	13.3
		8	17.8
	1.2	10	45.3
		8	49.8
	1.6	10	80.8
		8	84.7

**[0140]** As is illustrated in Table 1, a range of current densities was achieved across the electrode in the system. As can be appreciated, the current density that can be achieved with other configurations of the system may vary, depending on several factors including the cumulative electrical resistance losses in the cell, environmental test conditions, the overpotential associated with the anodic and cathodic reactions, and other factors.

**[0141]** The current densities achieved in the present configuration and as set forth in Table 1 are correlated with the production of hydroxide ions at the cathode, and thus are correlated with the production of sodium hydroxide and/or

sodium carbonate and/or sodium bicarbonate in the cathode electrolyte, as follows. With reference to Table 1, at 75° C., 0.8 V and a pH of 10, each cm<sup>2</sup> of electrode passed 13.3 mA of current, where current is a measure of charge passed (Coulomb) per time (second). Based on Faraday's Laws, the amount of product, e.g., hydroxide ions, produced at an electrode is proportional to the total electrical charge passed through the electrode as follows:

$$n=(I*t)/(F*z)$$

where n is moles of product, I is a current, t is time, F is Faraday's constant, and z is the electrons transferred per product ionic species (or reagent ionic species). Thus, based on the present example,  $1.38 \times 10^{-4}$  moles of hydroxide ions are produced per second per cm<sup>2</sup> of electrode, which is correlated with the production of sodium hydroxide in the cathode electrolyte. In the system the production rate of NaOH dictates the production rate of NaHCO<sub>3</sub> and Na<sub>2</sub>CO<sub>3</sub> through Le Chatelier's principle following the net chemical equilibria equations of

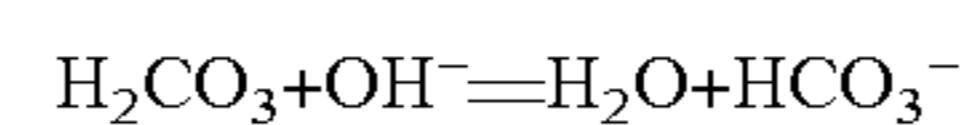

and

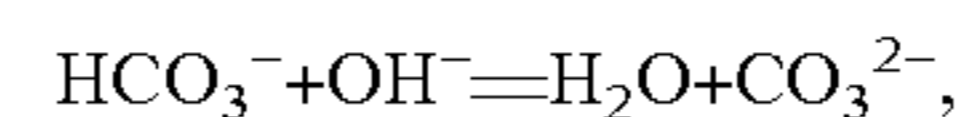

where an increase in concentration of one species in equilibria will change the concentration of all species so that the equilibrium product maintains the equilibrium constant. Thus, in the system, the equilibrium concentrations of H<sub>2</sub>CO<sub>3</sub>, HCO<sub>3</sub><sup>-</sup>, and CO<sub>3</sub><sup>2-</sup> vs. pH in the electrolyte will follow the carbonate speciation diagram as discussed above.

**[0142]** In the system as illustrated in FIGS. 1-9 and as discussed with reference to the carbonate speciation graph, supra, the solubility of carbon dioxide in the cathode electrolyte is dependent on the pH of the electrolyte. Also in the system, the voltage across the cathode and anode is dependent on several factors including the pH difference between the anode electrolyte and cathode electrolyte. Thus, in some embodiments the system can be configured to operate at a specified pH and voltage to absorb carbon dioxide and produce carbonic acid, carbonate ions and/or bicarbonate ions in the cathode electrolyte. In embodiments where carbon dioxide gas is dissolved in the cathode electrolyte, as protons are removed from the cathode electrolyte more carbon dioxide may be dissolved to form carbonic acid, bicarbonate ions and/or carbonate ions. Depending on the pH of the cathode electrolyte the balance is shifted toward bicarbonate ions or toward carbonate ions, as is well understood in the art and as is illustrated in the carbonate speciation diagram, above. In these embodiments the pH of the cathode electrolyte solution may decrease, remain the same, or increase, depending on the rate of removal of protons compared to rate of introduction of carbon dioxide. It will be appreciated that no carbonic acid, hydroxide ions, carbonate ions or bicarbonate ions are formed in these embodiments, or that carbonic acid, hydroxide ions, carbonate ions, bicarbonate ions may not form during one period but form during another period.

**[0143]** In another embodiment, the system and method are integrated with a carbonate and/or bicarbonate precipitation system (not illustrated) wherein a solution of divalent cations, when added to the present cathode electrolyte, causes formation of precipitates of divalent carbonate and/or bicarbonate compounds, e.g., calcium carbonate or magnesium carbonate and/or their bicarbonates. In some embodiments, the precipitated divalent carbonate and/or bicarbonate compounds may be utilized as building materials, e.g., cements and aggregates as described for example in commonly assigned U.S. patent

application Ser. No. 12/126,776 filed on May 23, 2008, herein incorporated by reference in its entirety.

**[0144]** In an alternative embodiment, the system and method are integrated with a mineral and/or material dissolution and recovery system (not illustrated) wherein the acidic anode electrolyte solution **104** or the basic cathode electrolyte **108** is utilized to dissolve calcium and/or magnesium-rich minerals e.g., serpentine or olivine, or waste materials, e.g., fly ash, red mud and the like, to form divalent cation solutions that may be utilized, e.g., to precipitate carbonates and/or bicarbonates as described herein. In some embodiments, the precipitated divalent carbonate and/or bicarbonate compounds may be utilized as building materials, e.g., cements and aggregates as described for example in commonly assigned U.S. patent application Ser. No. 12/126,776 filed on May 23, 2008, herein incorporated by reference in its entirety.

**[0145]** In an alternative embodiment, the system and method are integrated with an industrial waste gas treatment system (not illustrated) for sequestering carbon dioxide and other constituents of industrial waste gases, e.g., sulfur gases, nitrogen oxide gases, metal and particulates, wherein by contacting the flue gas with a solution comprising divalent cations and the present cathode electrolyte comprising hydroxide, bicarbonate and/or carbonate ions, divalent cation carbonates and/or bicarbonates are precipitated as described in commonly assigned U.S. patent application Ser. No. 12/344,019 filed on Dec. 24, 2008, herein incorporated by reference in its entirety. The precipitates, comprising, e.g., calcium and/or magnesium carbonates and bicarbonates in some embodiments may be utilized as building materials, e.g., as cements and aggregates, as described in commonly assigned U.S. patent application Ser. No. 12/126,776 filed on May 23, 2008, herein incorporated by reference in its entirety.

**[0146]** In another embodiment, the system and method are integrated with an aqueous desalination system (not illustrated) wherein the partially desalinated water of the third electrolyte of the present system is used as feed-water for the desalination system, as described in commonly assigned U.S. patent application Ser. No. 12/163,205 filed on Jun. 27, 2008, herein incorporated by reference in its entirety.

**[0147]** In an alternative embodiment, the system and method are integrated with a carbonate and/or bicarbonate solution disposal system (not illustrated) wherein, rather than producing precipitates by contacting a solution of divalent cations with the first electrolyte solution to form precipitates, the system produces a solution, slurry or suspension comprising carbonates and/or bicarbonates. In some embodiments, the solution, slurry or suspension is disposed of in a location where it is held stable for an extended periods of time, e.g., the solution/slurry/suspension is disposed in an ocean at a depth where the temperature and pressure are sufficient to keep the slurry stable indefinitely, as described in U.S. patent application Ser. No. 12/344,019 filed on Dec. 24, 2008, herein incorporated by reference in its entirety; or in a subterranean site.

1. A system comprising:  
an electrochemistry unit comprising a hydrogen-oxidizing anode in communication with a cathode electrolyte; wherein  
the electrochemistry unit is operably connected to a carbon sequestration system configured to sequester carbon dioxide with the cathode electrolyte.
2. The system of claim 1, further comprising a brine production system configured to provide cations to the cathode electrolyte.
3. (canceled)
4. The system of claim 2, wherein the cathode electrolyte comprises added carbon dioxide.

5. The system of claim 4, wherein the cathode electrolyte comprises hydroxide ions and/or carbonate ions.

6. (canceled)

7. (canceled)

8. The system of claim 5, configured to produce hydrogen and hydroxide ions at a cathode in contact with the cathode electrolyte, and oxidize hydrogen to protons at an anode in contact with an anode electrolyte without producing a gas at the anode, with a voltage applied across the anode and cathode.

9. The system of claim 8, wherein the voltage is less than 3V.

10. The system of claim 9, configured to produce an acid in the anode electrolyte.

11. (canceled)

12. The system of claim 10, further comprising an acid dissolution system configured to produce divalent cations with the acid.

13. (canceled)

14. The system of claim 1, wherein carbon dioxide is contained in an industrial waste gas.

15. The system of claim 14, wherein the carbon dioxide is sequestered as carbonate and/or bicarbonate.

16. (canceled)

17. (canceled)

18. (canceled)

19. A method comprising:

oxidizing hydrogen to protons at a hydrogen-oxidizing anode in communication with a cathode electrolyte; and sequestering carbon dioxide with the cathode electrolyte.

20. The method of claim 19, comprising providing cations from a brine to the cathode electrolyte.

21. (canceled)

22. (canceled)

23. The method of claim 20, comprising adding carbon dioxide to the cathode electrolyte.

24. The method of claim 23, comprising producing hydrogen gas and hydroxide ions at a cathode in contact with the cathode electrolyte without producing a gas at the anode, by applying a voltage across the anode and cathode.

25. The method of claim 24, wherein the voltage is less than 3V.

26. The method of claim 25, wherein the cathode electrolyte comprises hydroxide ions and/or bicarbonate ions and/or carbonate ions.

27. The method of claim 26, comprising separating cations and anions from the brine to produce an ion-depleted brine.

28. The method of claim 27, comprising producing an acid in the anode electrolyte.

29. (canceled)

30. (canceled)

31. (canceled)

32. The method of claim 19, wherein carbon dioxide is contained in an industrial waste gas.

33. The method of claim 32, wherein the carbon dioxide is sequestered as carbonate and/or bicarbonate.

34. (canceled)

35. (canceled)

36. (canceled)

37. (canceled)

38. A system comprising:

a hydrogen-oxidizing anode in communication with a cathode electrolyte comprising bicarbonate ions; and a

and a brine production system configured to provide cations to the cathode electrolyte.

39. (canceled)

40. The system of claim 38, wherein the cathode electrolyte comprises added carbon dioxide.

41. The system of claim 40, wherein the cathode electrolyte comprises hydroxide ions and/or carbonate ions.

42. (canceled)

43. The system of claim 41, wherein the cations comprises sodium ions.

44. The system of claim 43, configured to produce hydrogen and hydroxide ions at a cathode in contact with the cathode electrolyte, and oxidize hydrogen to protons at an anode in contact with an anode electrolyte without producing a gas at the anode, with a voltage applied across the anode and cathode.

45. The system of claim 44, wherein the voltage is less than 3V.

46. (canceled)

47. (canceled)

48. (canceled)

49. (canceled)

50. The system of claim 45, further comprising a carbon sequestration system configured to sequester carbon dioxide with the cathode electrolyte.

51. The system of claim 41, wherein carbon dioxide is contained in an industrial waste gas.

52. The system of claim 51, wherein the carbon dioxide is sequestered as carbonate and/or bicarbonate.

53. (canceled)

54. (canceled)

55. (canceled)

56. (canceled)

57. (canceled)

58. (canceled)

59. A method comprising:

oxidizing hydrogen to protons at a hydrogen-oxidizing anode in communication with a cathode electrolyte comprising bicarbonate ions; and providing cations from a brine to the cathode electrolyte.

60. (canceled)

61. (canceled)

62. The method of claim 59, comprising adding carbon dioxide to the cathode electrolyte.

63. The method of claim 62, comprising producing hydrogen gas and hydroxide ions at a cathode in contact with the cathode electrolyte without producing a gas at the anode, by applying a voltage across the anode and cathode.

64. The method of claim 63, wherein the voltage is less than 3V.

65. The method of claim 64, wherein the cathode electrolyte comprises hydroxide ions and/or carbonate ions.

66. The method of claim 65, comprising separating cations and anions from the brines to produce an ion-depleted brine.

67. The method of claim 66, comprising producing an acid in the anode electrolyte.

68. (canceled)

69. (canceled)

70. (canceled)

71. The method of claim 67, further comprising configuring a carbon sequestration system to sequester carbon dioxide with the cathode electrolyte.

72. The method of claim 62, wherein carbon dioxide is contained in an industrial waste gas.

73. The method of claim 72, wherein the carbon dioxide is sequestered as carbonate and/or bicarbonate.

74. (canceled)

75. (canceled)

76. The method of claim 73, comprising generating hydrogen gas and hydroxide ions by reducing water at the cathode.

77. (canceled)

78. (canceled)

79. (canceled)

80. (canceled)

\* \* \* \* \*