



(19) **United States**

(12) **Patent Application Publication**  
**Turner et al.**

(10) **Pub. No.: US 2010/0186446 A1**

(43) **Pub. Date: Jul. 29, 2010**

(54) **APPARATUS FOR THE LIQUEFACTION OF A GAS AND METHODS RELATING TO SAME**

(75) Inventors: **Terry D. Turner**, Idaho Falls, ID (US); **Bruce M. Wilding**, Idaho Falls, ID (US); **Michael G. McKellar**, Idaho Falls, ID (US)

Correspondence Address:  
**TraskBritt / Battelle Energy Alliance, LLC**  
**PO Box 2550**  
**Salt Lake City, UT 84110 (US)**

(73) Assignee: **BATTELLE ENERGY ALLIANCE, LLC**, Idaho Falls, ID (US)

(21) Appl. No.: **12/648,659**

(22) Filed: **Dec. 29, 2009**

**Related U.S. Application Data**

(60) Continuation of application No. 11/536,477, filed on Sep. 28, 2006, now Pat. No. 7,637,122, which is a continuation-in-part of application No. 11/124,589, filed on May 5, 2005, now Pat. No. 7,219,512, which is a continuation of application No. 10/414,991, filed on Apr. 14, 2003, now Pat. No. 6,962,061, which is a division of application No. 10/086,066, filed on Feb. 27, 2002, now Pat. No. 6,581,409, said application No. 11/536,477 is a continuation-in-part of application No. 11/381,904, filed on May 5, 2006, now Pat. No. 7,594,414, which is a continuation-in-part of application No.

11/124,589, filed on May 5, 2005, now Pat. No. 7,219,512, said application No. 11/536,477 is a continuation-in-part of application No. 11/383,411, filed on May 15, 2006, now Pat. No. 7,591,150, which is a continuation-in-part of application No. 11/124,589, filed on May 5, 2005, now Pat. No. 7,219,512, which is a continuation-in-part of application No. 11/381,904, filed on May 5, 2006, now Pat. No. 7,594,414.

(60) Provisional application No. 60/288,985, filed on May 4, 2001.

**Publication Classification**

(51) **Int. Cl.**  
**F25J 1/02** (2006.01)  
(52) **U.S. Cl.** ..... **62/611**

(57) **ABSTRACT**

Apparatuses and methods are provided for producing liquefied gas, such as liquefied natural gas. In one embodiment, a liquefaction plant may be coupled to a source of unpurified natural gas, such as a natural gas pipeline at a pressure let-down station. A portion of the gas is drawn off and split into a process stream and a cooling stream. The cooling stream may sequentially pass through a compressor and an expander. The process stream may also pass through a compressor. The compressed process stream is cooled, such as by the expanded cooling stream. The cooled, compressed process stream is expanded to liquefy the natural gas. A gas-liquid separator separates the vapor from the liquid natural gas. A portion of the liquid gas may be used for additional cooling. Gas produced within the system may be recompressed for reintroduction into a receiving line.

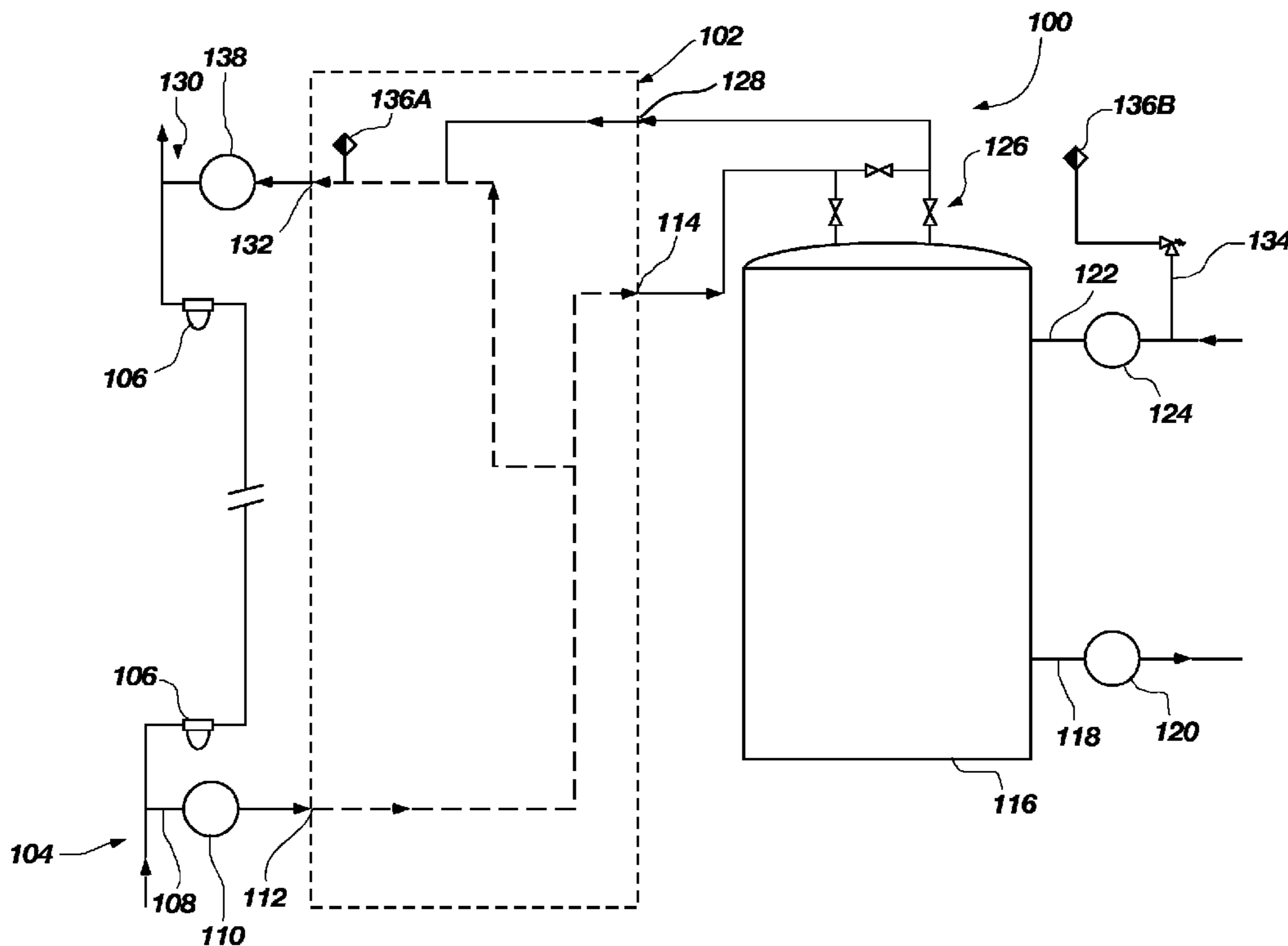

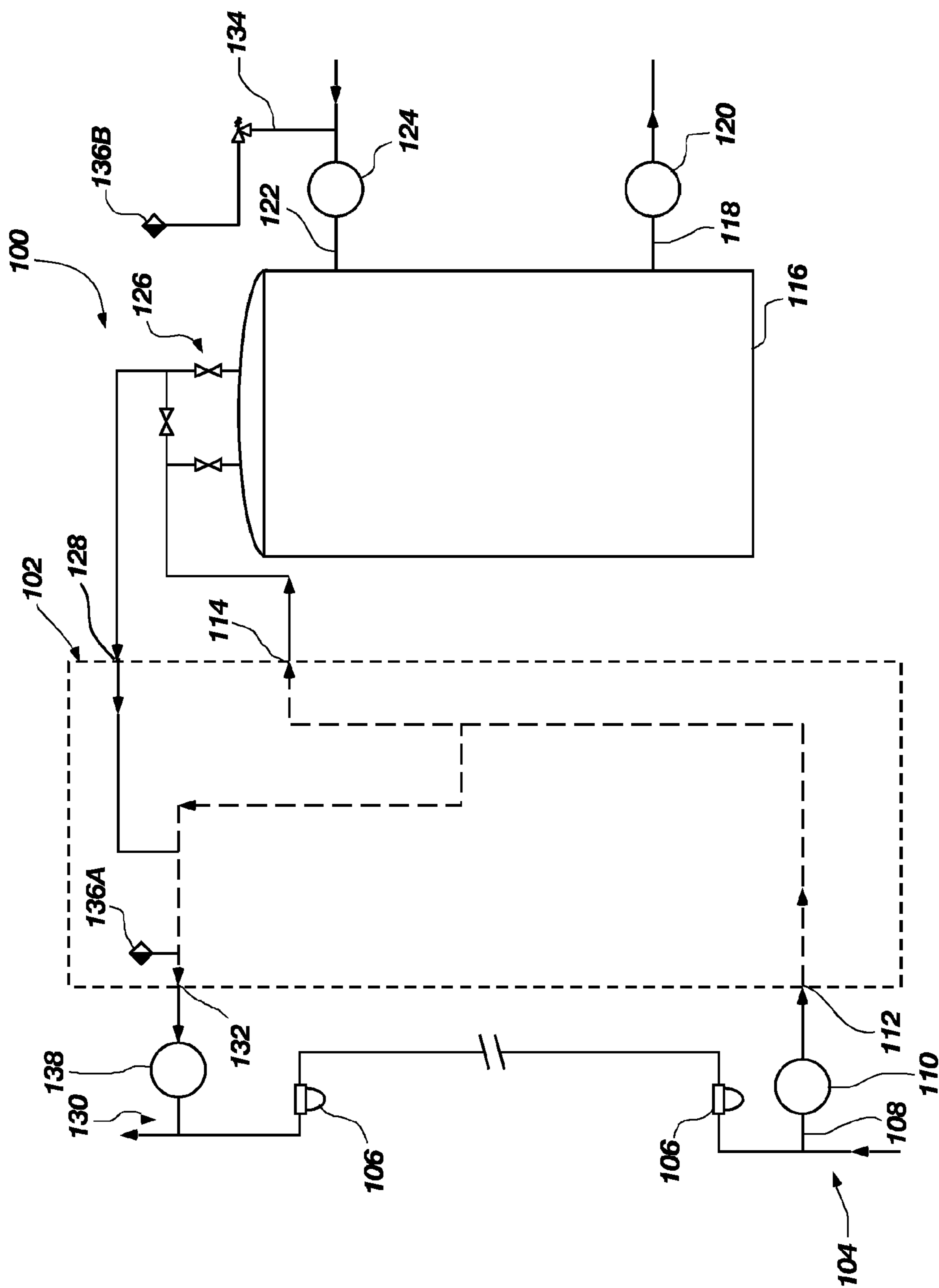

FIG. 1

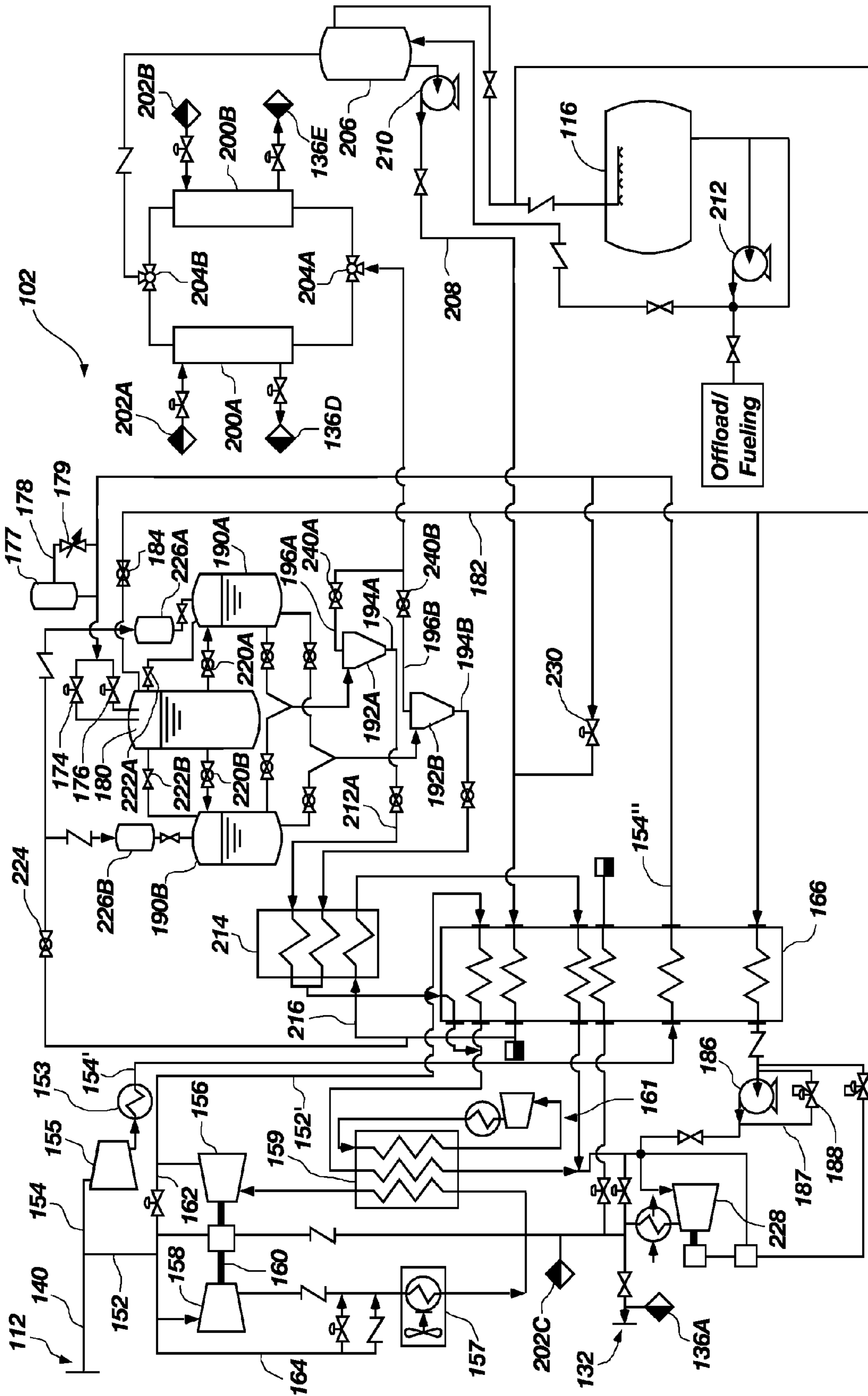

FIG. 2

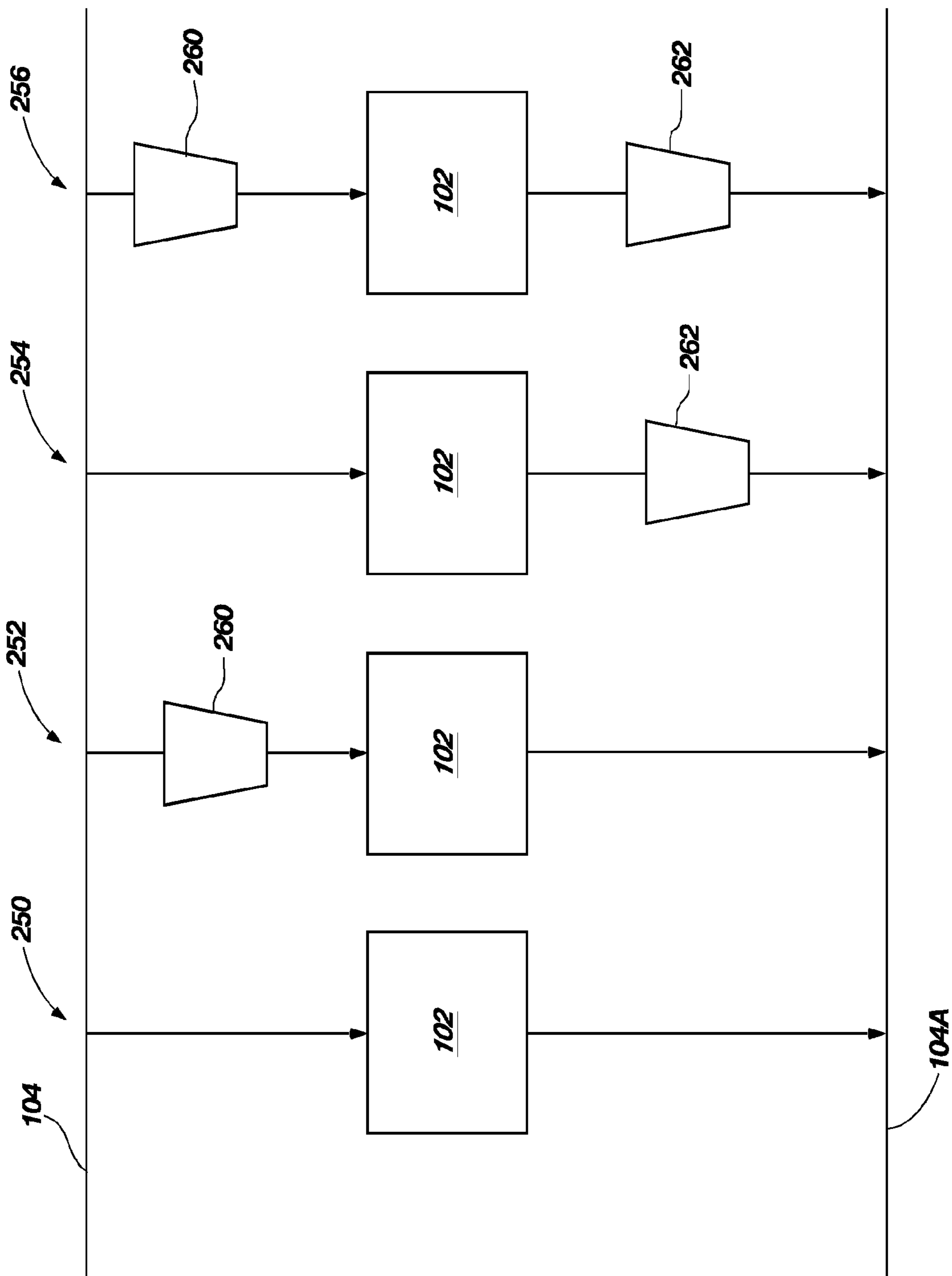

FIG. 3

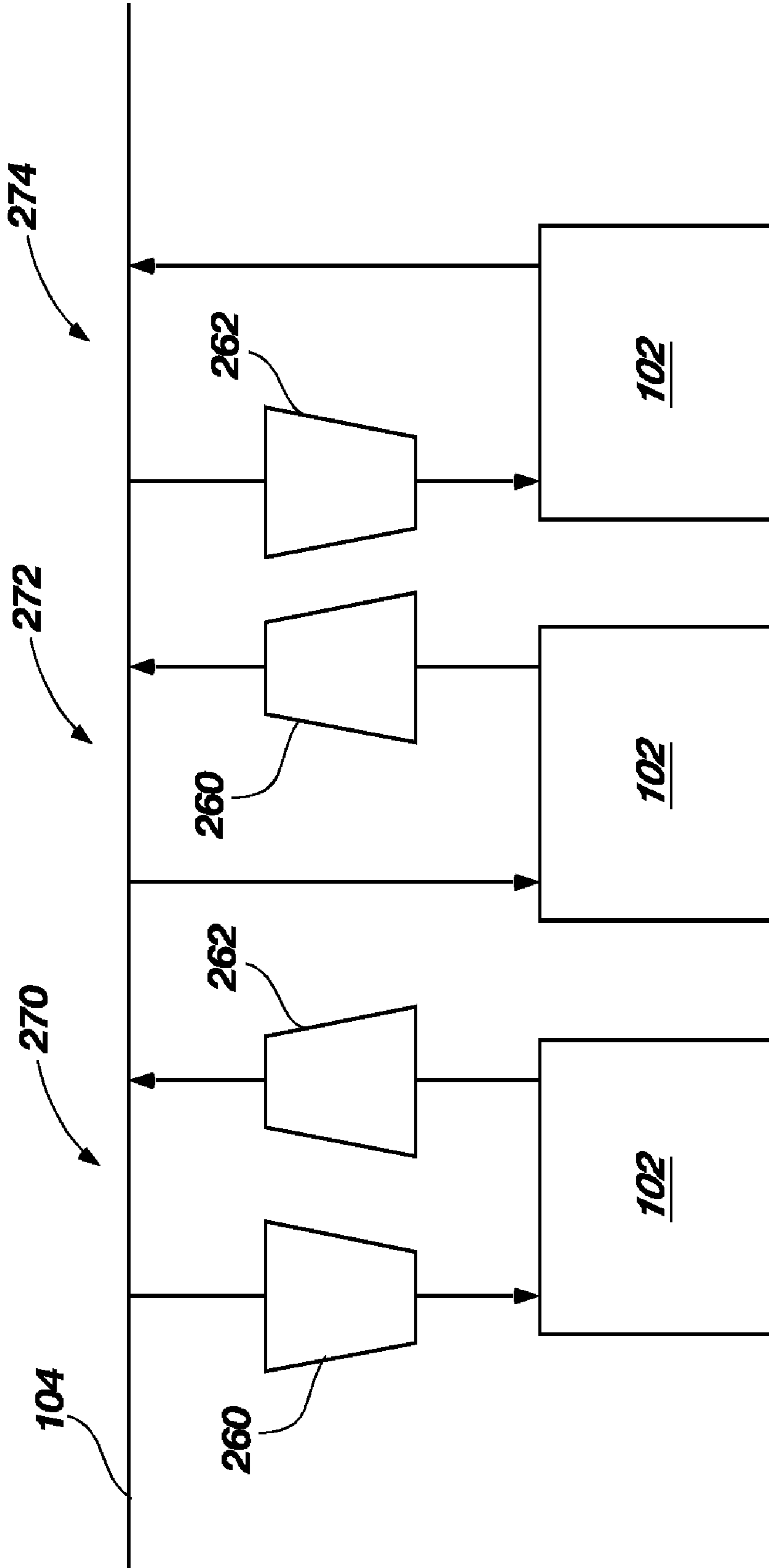

FIG. 4

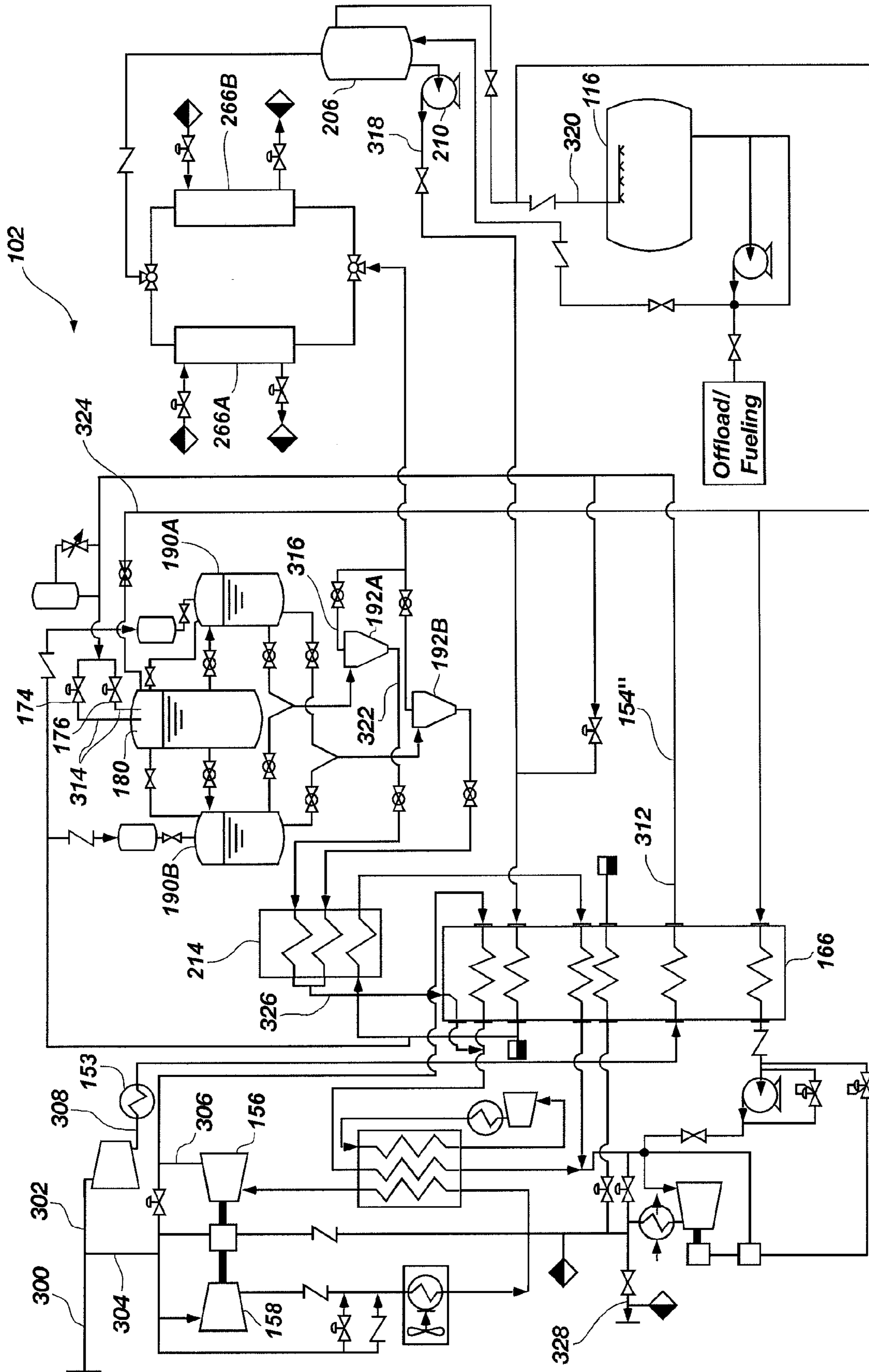

FIG. 5

**APPARATUS FOR THE LIQUEFACTION OF A  
GAS AND METHODS RELATING TO SAME**

CROSS-REFERENCE TO RELATED  
APPLICATIONS

[0001] This application is a continuation of U.S. patent application Ser. No. 11/536,477, filed Sep. 28, 2006, now U.S. Pat. No. 7,637,122, issued Dec. 29, 2009 (hereinafter referred to as “the ’122 patent”), which application is a continuation-in-part of U.S. patent application Ser. No. 11/124,589, filed May 5, 2005, now U.S. Pat. No. 7,219,512, issued May 22, 2007, which is a continuation of U.S. patent application Ser. No. 10/414,991, filed Apr. 14, 2003, now U.S. Pat. No. 6,962,061, issued Nov. 8, 2005, which is a divisional of U.S. patent application Ser. No. 10/086,066, filed Feb. 27, 2002, now U.S. Pat. No. 6,581,409, issued Jun. 24, 2003 and which claims the benefit of U.S. Provisional Patent Application Ser. No. 60/288,985, filed May 4, 2001. The ’122 patent is also a continuation-in-part of U.S. patent application Ser. No. 11/381,904, filed May 5, 2006, now U.S. Pat. No. 7,594,414, issued Sep. 29, 2009, entitled APPARATUS FOR THE LIQUEFACTION OF NATURAL GAS AND METHODS RELATING TO SAME, which is also a continuation-in-part of the above-referenced U.S. patent application Ser. No. 11/124,589, filed May 5, 2005, now U.S. Pat. No. 7,219,512, issued May 22, 2007. Further, the ’122 patent is a continuation-in-part of U.S. patent application Ser. No. 11/383,411, filed May 15, 2006, now U.S. Pat. No. 7,591,150, issued Sep. 22, 2009, entitled APPARATUS FOR THE LIQUEFACTION OF NATURAL GAS AND METHODS RELATING TO SAME, which is also a continuation-in-part of the above-referenced U.S. patent application Ser. No. 11/124,589, filed May 5, 2005, now U.S. Pat. No. 7,219,512, issued May 22, 2007, and U.S. patent application Ser. No. 11/381,904, filed May 5, 2006, now U.S. Pat. No. 7,594,414, issued Sep. 29, 2009. This application is also related to U.S. patent application Ser. No. 11/674,984, filed Feb. 14, 2007, pending, U.S. patent application Ser. No. 11/560,682, filed Nov. 16, 2006, pending, U.S. patent application Ser. No. 11/855,071, filed Sep. 13, 2007, pending, and U.S. patent application Ser. No. 09/643,420, filed Aug. 23, 2001, now U.S. Pat. No. 6,425,263, issued Jul. 30, 2002, which is a continuation of U.S. patent application Ser. No. 09/212,490, filed Dec. 16, 1998, now U.S. Pat. No. 6,105,390, issued Aug. 22, 2000, which claims benefit of U.S. Provisional Application Ser. No. 60/069,988 filed Dec. 16, 1997. The disclosure of each of the above-referenced U.S. priority patents and patent applications are incorporated herein by reference in their entirety.

GOVERNMENT RIGHTS

[0002] This invention was made with government support under Contract No. DE-AC07-051D14517 awarded by the U.S. Department of Energy. The United States Government has certain rights in this invention.

BACKGROUND OF THE INVENTION

[0003] 1. Field of the Invention

[0004] The present invention relates generally to the compression and liquefaction of gases and, more particularly, to the liquefaction of a gas, such as natural gas, on a relatively small scale by, for example, utilizing a combined refrigerant and expansion process.

[0005] 2. State of the Art

[0006] Natural gas is a known alternative to combustion fuels such as gasoline and diesel. Much effort has gone into the development of natural gas as an alternative combustion fuel in order to combat various drawbacks of gasoline and diesel including production costs and the subsequent emissions created by the use thereof. As is known in the art, natural gas is a cleaner burning fuel than other combustion fuels. Additionally, natural gas is considered to be safer than gasoline or diesel, as leaking natural gas will rise in the air and dissipate, rather than settling or accumulating.

[0007] To be used as an alternative combustion fuel, natural gas (also termed “feed gas” herein) is conventionally converted into compressed natural gas (CNG) or liquified (or liquid) natural gas (LNG) for purposes of storing and transporting the fuel prior to its use. Conventionally, two of the known, basic processes used for the liquefaction of natural gases are referred to as the “cascade cycle” and the “expansion cycle.”

[0008] Briefly, the cascade cycle consists of subjecting the feed gas to a series of heat exchanges, each exchange being at successively lower temperatures until the desired liquefaction is accomplished. The levels of refrigeration are obtained with different refrigerants or with the same refrigerant at different evaporating pressures. The cascade cycle is considered to be relatively efficient at producing LNG as operating costs are relatively low. However, the efficiency in operation is often seen to be offset by the relatively high investment costs associated with the expensive heat exchange equipment and the compression equipment associated with the refrigerant system. Additionally, a liquefaction plant incorporating such a system may be impractical where physical space is limited, as the physical components used in cascading systems are relatively large.

[0009] In an expansion cycle, gas is conventionally compressed to a selected pressure, cooled, and then allowed to expand through an expansion turbine, thereby producing work as well as reducing the temperature of the feed gas. The low temperature feed gas is then heat exchanged to effect liquefaction of the feed gas. Conventionally, such a cycle has been seen as being impracticable in the liquefaction of natural gas since there is no provision for handling some of the components present in natural gas which freeze at the temperatures encountered in the heat exchangers, such as, for example, water and carbon dioxide. It is noted that the need for expensive pre-clean-up or pre-purification is also an issue associated with the cascade cycle.

[0010] Additionally, to make the operation of conventional systems cost effective, such systems are conventionally built on a large scale for the processing of large volumes of natural gas. As a result, fewer facilities are built overall, making it more difficult to provide the raw gas to the liquefaction plant or facility as well as making distribution of the liquefied product an issue. Another major issue with large-scale facilities is the capital and operating expenses associated therewith. For example, a conventional large-scale liquefaction plant, i.e., producing on the order of 70,000 gallons of LNG per day, may cost \$2 million to \$15 million, or more, in capital expenses. Also, such a plant may require thousands of horsepower to drive the compressors associated with the refrigerant cycles, making the daily operation of the plants expensive.

[0011] An additional problem with large facilities is the cost associated with storing large amounts of fuel in anticipation of future use and/or transportation. Not only is there a

cost associated with building large storage facilities, but there is also an efficiency issue related therewith. For example, stored LNG will tend to warm and vaporize over time, creating a loss of the LNG fuel product. Further, safety may become an issue when larger volumes of LNG fuel product are stored.

**[0012]** In confronting the foregoing issues, various systems have been devised which attempt to produce LNG or CNG from feed gas on a smaller scale, in an effort to eliminate long-term storage issues and to reduce the capital and operating expenses associated with the liquefaction and/or compression of natural gas. However, such systems and techniques have all suffered from one or more drawbacks.

**[0013]** U.S. Pat. No. 5,505,232 to Barclay, issued Apr. 9, 1996 is directed to a system for producing LNG and/or CNG. The disclosed system is stated to operate on a small scale, producing approximately 1,000 gallons a day of liquefied or compressed fuel product. However, the liquefaction portion of the system itself requires the flow of a “clean” or “purified” gas, meaning that various constituents in the gas such as carbon dioxide, water, or heavy hydrocarbons must be removed before the actual liquefaction process can begin.

**[0014]** Similarly, U.S. Pat. Nos. 6,085,546 and 6,085,547 both issued Jul. 11, 2000 to Johnston, describe methods and systems of producing LNG. The Johnston patents are both directed to small-scale production of LNG, but again, both require “pre-purification” of the gas in order to implement the actual liquefaction cycle. The need to provide “clean” or “pre-purified” gas to the liquefaction cycle is based on the fact that certain gas components might freeze and plug the system during the liquefaction process because of their relatively higher freezing points as compared to methane, which makes up the larger portion of natural gas.

**[0015]** Since many sources of natural gas, such as residential or industrial service gas, are considered to be relatively “dirty,” the requirement of providing “clean” or “pre-purified” gas is actually a requirement of implementing expensive and often complex filtration and purification systems prior to the liquefaction process. This requirement simply adds expense and complexity to the construction and operation of such liquefaction plants or facilities.

**[0016]** In view of the shortcomings in the art, it would be advantageous to provide a process, and a system or a plant for carrying out such a process, of efficiently producing liquefied natural gas on a small scale. Additionally, it would be advantageous to provide a system for producing liquefied natural gas from a source of relatively “dirty” or “unpurified” natural gas without the need for “pre-purification.” Such a system or process may include various clean-up cycles which are integrated with the liquefaction cycle for purposes of efficiency.

**[0017]** It would be additionally advantageous to provide a plant or a system for the liquefaction of natural gas which is relatively inexpensive to build and operate, and which desirably requires little or no operator oversight.

**[0018]** It would be additionally advantageous to provide such a plant or a system which is easily transportable and which may be located and operated at existing sources of natural gas which are within or near populated communities, thus providing easy access for consumers of LNG fuel.

**[0019]** It is a continual desire to improve the efficiency and effectiveness of liquefaction processes and systems.

#### BRIEF SUMMARY OF THE INVENTION

**[0020]** In one embodiment of the invention, a method of liquefying a gas is provided. The method includes providing

a source of the gas and flowing a portion of the gas from the source. The portion of gas is divided into at least a process stream and a cooling stream. The process stream is flowed sequentially through a first compressor and a first side of at least one heat exchanger. The cooling stream is flowed sequentially through a second compressor and a second side of the at least one heat exchanger. The at least a portion of the process stream is expanded subsequent flowing the process stream through the first side of at least one heat exchanger to produce a liquid.

**[0021]** The method may further include cooling the process stream to form a slurry within the separator, the slurry comprising at least liquid natural gas and solid carbon dioxide. Cooling the portion of the mass of natural gas may be accomplished by expanding the gas, such as through one or more Joule-Thomson valves. The slurry may be flowed into one or more hydrocyclones by way of one or more pressurized transfer tanks. The transfer tanks may be used alternately or sequentially so as to provide a continuous transfer of slurry to the hydrocyclones. The hydrocyclones substantially separate the solid carbon dioxide and the liquid natural gas. A thickened slush may exit an underflow of the hydrocyclone wherein the thickened slush may include the solid carbon dioxide and a portion of the liquid natural gas. The remaining portion of liquid natural gas is flowed through an overflow of the hydrocyclone.

**[0022]** In another embodiment of the present invention, a liquefaction apparatus or system, which may also be termed a “plant,” is provided. The liquefaction plant includes a first flow path defined and configured for sequential delivery of a first stream of gas through a first compressor and a first side of at least one heat exchanger and a second flow path defined and configured for sequential delivery of a second stream of gas through a second compressor and a second side of the at least one heat exchanger. A product flow path is defined and configured for delivery of the first stream of gas from the first flow path through at least one expansion device and into a gas-liquid separator.

**[0023]** The liquefaction plant may include additional components including a plurality of transfer tanks configured to sequentially or alternately fill with slurry and transfer the slurry to one or more hydrocyclones. The hydrocyclones may be used to separate solids from the liquids. Additionally, filters may be used to further remove solids from the liquids. A sublimation tank may be coupled to the hydrocyclones and configured to receive the solids and sublime them back to a gaseous state.

#### BRIEF DESCRIPTION OF THE SEVERAL VIEWS OF THE DRAWINGS

**[0024]** The foregoing and other advantages of the invention will become apparent upon reading the following detailed description and upon reference to the drawings in which:

**[0025]** FIG. 1 is a schematic overview of a liquefaction plant according to one embodiment of the present invention;

**[0026]** FIG. 2 is a process flow diagram depicting a liquefaction cycle according to one embodiment of the present invention;

**[0027]** FIGS. 3 and 4 are schematics showing various configurations for embodiments of the present invention based on site options and supply conditions; and



[0028] FIG. 5 is a process flow diagram showing state points of flow mass throughout a liquefaction system according to one embodiment of the present invention.

#### DETAILED DESCRIPTION OF THE INVENTION

[0029] Referring to FIG. 1, a schematic overview of a portion of a liquefied natural gas (LNG) station 100 is shown according to one embodiment of the present invention. It is noted that, while the present invention is set forth in terms of liquefaction of natural gas, the present invention may be utilized for the liquefaction of other gases as will be appreciated and understood by those of ordinary skill in the art.

[0030] The liquefaction station 100 includes a “small-scale” natural gas liquefaction plant 102, which is coupled to a source of natural gas such as a supply line or a pipeline 104, although other sources, such as a well head, are contemplated as being equally suitable. The term “small-scale” is used to differentiate such a plant from a larger-scale plant having the capacity of producing, for example, 70,000 gallons of LNG or more per day. In comparison, the presently disclosed liquefaction plant may have the capacity of producing, for example, approximately 10,000 gallons of LNG a day but may be scaled to produce a different output as needed and is not limited to small-scale operations or plants. Additionally, the liquefaction plant 102 of the present invention is considerably smaller in physical size than conventional large-scale plants and may be readily transported from one site to another.

[0031] One or more pressure regulators 106 may be positioned along the pipeline 104 for controlling the pressure of the gas flowing therethrough. Such a configuration is representative of a pressure letdown station wherein the pressure of the natural gas is reduced from high transmission pressures at an upstream location to a pressure suitable for distribution to one or more customers at a downstream location. Upstream of the pressure regulators 106, for example, the pressure in the pipeline 104 may be approximately 600 to 800 pounds per square inch gauge (psig) while the pressure downstream of the pressure regulators 106 may be reduced to approximately 470 psig, or less. Of course, such pressures are merely examples and may vary depending on the particular pipeline 104 and the needs of the downstream customers. It is noted that the available pressure of the upstream gas in the pipeline 104 (i.e., at plant inlet 112) is not critical as the pressure thereof may be raised, for example, by use of an auxiliary booster pump, compressor, or heat exchanger prior to the gas entering the liquefaction process described herein. However, it is believed that, generally, higher supply pressures will provide increased yields of liquefied natural gas.

[0032] It is further noted that the pressure regulators 106 may be positioned near the liquefaction plant 102 or at some distance therefrom. As will be appreciated by those of ordinary skill in the art, in some embodiments such pressure regulators 106 may be associated with, for example, low pressure lines crossing with high pressure lines or with different flow circuits.

[0033] Prior to any reduction in pressure along the pipeline 104, a stream of feed gas 108 is split off from the pipeline 104 and fed through a flow meter 110 that measures and records the amount of gas flowing therethrough. The stream of feed gas 108 then enters the small-scale liquefaction plant 102 through a plant inlet 112 for processing, as will be set forth in further detail hereinbelow. A portion of the feed gas 108 entering the liquefaction plant 102 becomes LNG and exits

the liquefaction plant 102 at a plant outlet 114 for storage in a suitable tank or vessel 116. In one embodiment, the vessel 116 is configured to hold at least 10,000 gallons of LNG at a pressure of approximately 50 pounds per square inch absolute (psia) and at temperatures, for example, as low as approximately  $-230^{\circ}$  F. However, other vessel sizes and configurations may be utilized, for example, depending on specific output and storage requirements associated with the liquefaction plant 102.

[0034] A vessel outlet 118 is coupled to a flow meter 120 in association with dispensing the LNG from the vessel 116, such as to a vehicle that is powered by LNG or into a transport vehicle as may be required. A vessel inlet 122, coupled with a valve/meter set 124 which could include flow and/or process measurement devices, enables the venting and/or purging of a vehicle’s tank during dispensing of LNG from the vessel 116. Piping 126 associated with the vessel 116 and connected with a second plant inlet 128 provides flexibility in controlling the flow of LNG from the liquefaction plant 102 and also enables the flow to be diverted away from the vessel 116, recirculated through the liquefaction plant 102, or for drawing vapor from the vessel 116, if such actions should be desirable depending on the operation mode and conditions of the liquefaction plant 102.

[0035] The liquefaction plant 102 is also coupled to a downstream section 130 of the pipeline 104 at a second plant outlet 132 for discharging the portion of natural gas not liquefied during the process conducted within liquefaction plant 102, along with other constituents which may be removed during production of the LNG. Optionally, adjacent the vessel inlet 122, vent piping 134 may be coupled with piping of liquefaction plant 102 as indicated by interface connections 136A and 136B. Such vent piping 134 will similarly carry gas into the downstream section 130 of the pipeline 104. As noted above, while the second plant outlet 132 is shown as being coupled with the pipeline 104, the second plant outlet 132 could actually be configured for discharging into a different pipeline, a different circuit of the same pipeline, or into some other structure if desired.

[0036] Assuming that the second plant outlet 132 is coupled with the pipeline 104, as the various gas components leave the liquefaction plant 102 and enter into the downstream section 130 of the pipeline 104, a valve/meter set 138, which could include flow and/or process measuring devices, may be used to measure the flow of gas therethrough. The valve/meter sets 124 and 138, as well as the flow meters 110 and 120, may be positioned outside of the liquefaction plant 102 and/or inside the liquefaction plant 102 as may be desired. Thus, flow meters 110 and 120, when the outputs thereof are compared, help to determine the net amount of feed gas 140 removed from the pipeline 104 as the upstream flow meter 110 measures the gross amount of feed gas 140 removed and the downstream flow meter 138 measures the amount of gas placed back into the pipeline 104, the difference being the net amount of feed gas 140 removed from pipeline 104. Similarly, optional flow meter 120 and valve/meter set 124 indicate the net discharge of LNG from the vessel 116.

[0037] Referring now to FIG. 2, a process flow diagram is shown, representative of an embodiment of the liquefaction plant 102 schematically depicted in FIG. 1. As previously indicated with respect to FIG. 1, a high pressure stream of feed gas 140 (e.g., 600 psia to 800 psia), for example, at a temperature of approximately  $60^{\circ}$  F. enters the liquefaction plant 102 through the plant inlet 112. While not specifically

depicted, prior to processing the feed gas **140**, a small portion of feed gas **140** may be split off, passed through a drying filter and utilized as instrument control gas in conjunction with operating and controlling various components in the liquefaction plant **102**.

[0038] In another embodiment, a separate source of instrument gas, such as, for example, nitrogen, may be provided for controlling various instruments and components within the liquefaction plant **102**. As will be appreciated by those of ordinary skill in the art, other instrument controls including, for example, mechanical, electromechanical, or electromagnetic actuation, may likewise be implemented.

[0039] Upon entry into the liquefaction plant **102**, the feed gas **140** may flow through a filter to remove any sizeable objects which might cause damage to, or otherwise obstruct, the flow of gas through the various components of the liquefaction plant **102**. Such a filter may additionally be utilized to remove certain liquid and solid components. Such a filter and its operation have been set forth in greater detail in the various U.S. priority patents and patent applications previously incorporated herein by reference.

[0040] The feed gas **140** entering the liquefaction plant **102** is split into a cooling stream **152** and a process stream **154**. The process stream **154**, or at least a portion thereof, is eventually liquefied, while the cooling stream **152** is utilized to help produce the liquefied gas from the process stream **154**. While the embodiment shown and described with respect to FIG. **2** depicts a single stream of feed gas **140**, it is noted that separate streams may be provided from a source, such as from the pipeline **104**, to provide the single stream of feed gas **140** to the process stream **154** and the cooling stream **152**.

[0041] Considering the process stream **154** first, the process stream **154** passes through a compressor **155** where the pressure of the process stream **154** is raised to a pressure of approximately 740 psia and a temperature of approximately 102° F. The compressed process stream **154'** may pass through a heat exchanger **153** to provide an initial reduction in temperature, and is then passed through a high-efficiency heat exchanger **166** to reduce the temperature of the compressed product stream **154'** to a temperature of approximately -195° F. at a pressure of approximately 740 psia. By initially compressing the process stream **154**, a larger volume of produced liquid may be realized. Additionally, elevated pressures help to keep any CO<sub>2</sub> contained within the process stream **154** from plugging the various downstream flow paths.

[0042] As set forth in substantial detail in the U.S. priority patents and patent applications which have been incorporated herein by reference, a water clean-up cycle may be introduced into the process stream **154** or the compressed process stream **154'** to remove a water constituent from the feed gas **140** prior to the gas being liquefied. In one embodiment, methanol may be utilized to remove such water from the gas flowing through the process stream **154** and compressed process stream **154'**. When methanol is used, it is mixed with the gas stream to lower the freezing point of any water which may be contained therein. The methanol mixes with the gas stream and binds with the water to prevent the formation of ice in one or more flow paths defined within the liquefaction process.

[0043] The cooling stream **152** flows through a rotary compressor **158**, through a first heat exchanger **157**, a second heat exchanger **159** and then through a turbo expander **156**. The first heat exchanger **157** may include, for example, an ambient heat exchanger and the second heat exchanger **159** may include, for example, a counter-flow type heat exchanger that

subjects the cooling stream **152** to a flow of refrigerant. The refrigerant may include a dedicated flow of refrigerant, a flow of cooled gas, as shall be discussed in further detail hereinbelow, or both dedicated refrigerant and a flow of cooled gas. As shown in FIG. **2**, both a flow of cooled gas (i.e., the expanded cooling stream **152'** after it has exited the heat exchanger **166**) and a dedicated refrigerant loop **161** is utilized in conjunction with the second heat exchanger **159**.

[0044] In one embodiment, after being compressed and flowing through the first and second heat exchangers **157** and **159**, the cooling stream **152** may enter a turbo expander **156** at a pressure of approximately 800 psia and at a temperature of approximately -52° F. and is expanded to form an expanded cooling stream **152'** exhibiting a lower pressure, for example approximately 215 psia, and a reduced temperature of, for example, approximately -157° F. As will be seen hereinbelow, the expanded cooling stream **152'** is a cold mass of fluid that provides cooling during the process of producing liquefied gas.

[0045] The turbo expander **156** may include a turbine that expands the gas and extracts power from the expansion process. The compressor **158** may include a rotary compressor **158** that may be coupled to the turbo expander **156** by mechanical means, such as through a shaft **160**, so as to utilize the power generated by the turbo expander **156** to compress the process stream **154**. In one embodiment, the reduction of pressure of the cooling stream **152** as it flows across the turbo expander **156**, provides a substantial portion of the energy used in the liquefaction plant **102**, including the power to provide the initial compression of the cooling stream **152**, making it more economical to operate the liquefaction plant **102**.

[0046] In one embodiment, the turbo expander **156** and the compressor **158** system may be designed to operate at up to at least approximately 840 psig at 22,000 pounds mass per hour. The turbo expander **156**/compressor **158** system may also be fitted with gas bearings. Such gas bearings may be supplied with gas through a supply line **155** which draws a portion of the feed gas **140** therethrough. However, the portion of gas directed to any such gas bearing is relatively insubstantial as compared to the mass of gas flowing through the cooling and process lines **152** and **154**. In another embodiment, gas bearings may be supplied by a separate flow of gas such as nitrogen. In yet another embodiment, the turbo expander **156**/compressor **158** system may be fitted with other types of bearings including, for example, magnetic bearings or oil bearings.

[0047] The expanded cooling stream **152'** passes through the heat exchanger **166** to provide cooling to the compressed process stream **154'**. After exiting the heat exchanger **166**, the expanded cooling stream **152'** enters the cold side of the heat exchanger **159**. After exiting the heat exchanger **159**, the expanded cooling stream **152'** may be mixed with other streams and may be compressed or otherwise processed prior to exiting the liquefaction plant **102**.

[0048] Bypass piping **162** may be used to route the process stream **154** around the compressor **158**, the first and second heat exchangers **157** and **159**, and the turbo expander **156**. Additionally, bypass piping **164** may be used to route the process stream **154** around only the compressor **158**. The bypass piping **162** and **164** may be used during start-up of the liquefaction plant **102** to bring certain components to a steady state condition prior to the processing of LNG within the liquefaction plant **102**. For example, the bypass piping **162**

and **164** may be used while various components (such as the heat exchanger **166** which will be discussed hereinbelow), are gradually brought to a steady state temperature so as to avoid inducing thermal shock in such components. Additionally, if the pressure of the feed gas **140** is sufficient, the rotary compressor **158** need not be used and the cooling stream **152** may continue through the bypass piping **164**. Indeed, if it is known that the pressure of the feed gas **140** will remain at a sufficiently high pressure, the compressor **158** could conceivably be eliminated. In such a case, where the compressor **158** is not being utilized, the work generated by the turbo expander **156** could be utilized to drive a generator or provide power to some other component if desired. The bypass piping **164** additionally protects the compressor **158** from surging in the event of off-normal flow disruption. For example, if a reduced level of flow through the compressor **158** is sensed or otherwise determined for a given rotational speed of the compressor **158**, valves may be opened to recirculate high pressure gas through the bypass piping **164** to the inlet side of the compressor **158**.

[0049] In one embodiment, the heat exchanger **166** is a high-efficiency heat exchanger made from aluminum. In start-up situations it may be desirable to reduce the temperature of such a heat exchanger **166** by, for example, as much as approximately 1.8° F. per minute until a defined temperature limit is achieved. During start-up of the liquefaction plant **102**, the temperature of the heat exchanger **166** may be monitored as it incrementally decreases. Valving and other instruments may be controlled in order to effect the rate and pressure of flow in the cooling stream **152** and process stream **154**, which ultimately controls the cooling rate of heat exchanger **166** and/or other components of the liquefaction plant **102**.

[0050] Additionally, during start-up, it may be desirable to have an amount of LNG already present in the storage tank **116** (FIG. 1). Some of the LNG may be cycled through the system in order to cool various components if so desired or deemed necessary. Also, as will become apparent upon further reading of the description below, other cooling devices, including additional JT valves, located in various "loops" or flow streams may likewise be controlled during start-up in order to cool down the heat exchanger **166** or other components of the liquefaction plant **102**.

[0051] When the liquefaction plant **102** or liquefaction system **100** is in a steady state condition, the process stream **154** flows through the compressor **155** raising the pressure of the process stream **154**. The compression process is not thermodynamically ideal and, therefore, adds heat to the process stream **154** as it is compressed. To remove heat from the compressed process stream **154'**, it is flowed through the high-efficiency heat exchanger **166** and is cooled to a very low temperature, for example approximately -190° F. to -195° F. at a pressure, for example, of approximately 740 psia. It is noted that, if the heat of compression is too high, the gas may be precooled, for example, by an ambient heat exchanger **153** prior to its entry into the heat exchanger **166** as previously discussed. The heat exchanger **166** may include a high-efficiency heat exchanger and, in one embodiment, may be formed as a countercurrent flow, plate and fin type heat exchanger. Additionally, the plates and fins may be formed of a highly thermally conductive material such as, for example, aluminum. In one embodiment, a high-efficiency heat exchanger may include a multipass heat exchanger available from Chart Industries, Inc. of La Crosse, Wis.

[0052] The heat exchanger **166** is positioned and configured to efficiently transfer as much heat as possible away from the compressed process stream **154'** as it passes therethrough. The liquefaction plant **102** is desirably configured such that temperatures generated within the heat exchanger **166** are never low enough to generate solid CO<sub>2</sub> which may be present in the feed gas **140**, and which formation of solid CO<sub>2</sub> might result in blockage in the flow path of the compressed process stream **154'**.

[0053] After exiting the heat exchanger **166**, the cooled, compressed process stream **154"** (referred to hereinafter as the product stream **154"** for purposes of convenience) flows through two expansion valves, such as JT valves **174** and **176**, respectively, and into a liquid/vapor separator **180**. The two JT valves **174** and **176** are arranged in a parallel flow configuration and work in concert with one another to control the flow of the product stream **154"** into the liquid/vapor separator **180**. In one embodiment, the two JT valves **174** and **176** are of different sizes. In other words, the two JT valves **174** and **176** may exhibit different flow coefficients (C<sub>v</sub>). For example, in one embodiment, one JT valve **174** may be sized and configured to accommodate approximately 80% of the flow entering into the liquid/vapor separator **180** from the product stream **154"** while the other JT valve **176** may be sized and configured to accommodate the remaining approximately 20% of the flow.

[0054] In one embodiment, the larger of the two JT valves **174** and **176** is held at a constant position while the valve carrying the remaining flow is used for the fine control required to maintain a desired flow rate. As the gas expands through the valves, a Joule-Thomson (JT) valve effect reduces the temperature and pressure from, for example, approximately 740 psia at approximately -195° F. to approximately 50 psia and approximately -230° F. (which is the saturation temperature and pressure for the liquid). This pressure drop also precipitates solid CO<sub>2</sub>. The three phase (gas, liquid, and solid CO<sub>2</sub>) mixture exiting the JT valves **174** and **176** is collected in the liquid/vapor separator **180**, wherein a slurry comprising liquid natural gas and solid CO<sub>2</sub> is formed and the vapor is separated therefrom.

[0055] While a single valve may be used instead of the two JT valves **174** and **176**, the use of two (or more) JT valves **174** and **176** provides a more controlled flow and reduces shock or fluctuation in the product stream **154"**. Additionally, the use of multiple valves may be beneficial during start-up of the liquefaction plant **102** because the gas is less dense in such circumstances.

[0056] An accumulator **177** may be coupled with the product stream **154"** prior to the stream flowing through the JT valves **174** and **176** to further dampen flow pulses that may be introduced into the product stream **154"** by the JT valves **174** and **176**. A pressure sense line **178** may extend between the accumulator **177** and the product stream **154"** and may be buffered by a restrictive valve **179**. Additionally, the accumulator **177** may be directly coupled to the product stream **154"**.

[0057] When the product stream **154"** passes through the two expansion valves, such as JT valves **174** and **176**, respectively, the product stream **154"** follows a constant enthalpy pressure drop that changes from a high pressure, single phase mixture at a high pressure and low temperature (e.g., approximately 740 psia and approximately -195° F.) to three phases (solid, liquid, and gas) with approximately 10% to 28% mass flow being vapor, at a reduced pressure of, for example, 50 psia. The solid component includes solid CO<sub>2</sub>. The vapor

component from the liquid/vapor separator **180** is collected and removed therefrom through line **182** and is drawn by the suction side of a compressor **186** through the heat exchanger **166** to provide additional cooling. While shown to be located on the warm side of the heat exchanger **166**, the compressor **186** could be positioned on the cold side of the heat exchanger **166**, although such positioning might require the compressor **186** to be configured as a cryogenic compressor. In one embodiment, the compressor **186** may be powered by an internal combustion engine driven by a portion of the natural gas flowing through the liquefaction plant **102**. In another embodiment, the compressor **186** may be powered by electricity or other means as will be appreciated by those of ordinary skill in the art. It is further noted that a device such as an ejector or an eductor might be utilized in place of the compressor **186** in another embodiment.

[0058] To maintain the liquid/vapor separator **180** at a desired pressure, for example, at approximately 50 psia, the compressor **186** may be used to recompress the excess gas from the liquid/vapor separator **180**. The compressor **186** may also be coupled to a vent line associated with the storage tank **116** to likewise help maintain the pressure within storage tank **116** at substantially the same pressure as that of the liquid/vapor separator **180**.

[0059] A make-up line **187** having a regulator **188** may be routed around the compressor **186** to prevent flow surges as may be the case when gas from the liquid/vapor separator **180** and or storage tank **116** is relatively low. The pressure of such a regulator **188** may be set at a level that is just under the desired saturation pressure for the liquid/vapor separator **180**. In one embodiment, a floating ball check valve may also be installed in the suction line of the compressor **186** to prevent a sudden surge of liquid. If the compressor **186** is located on the cold side of the heat exchanger **166**, a floating ball check valve may also be used to prevent any accumulated liquid from entering the suction side of the compressor **186**. It is noted that if the compressor **186** is located on the warm side of the heat exchanger **166**, no liquid will be present at the suction side of the compressor **186** under normal operating conditions.

[0060] A back-pressure regulator **184** may be located in the vapor line **182** to also help control the pressure within the liquid/vapor separator **180**. In one example, the back pressure regulator **184** may be configured with a set-point of approximately 50 psia so as to create a saturation pressure of the liquid that is below a desired transfer pressure (i.e., the pressure used to transfer liquid from the liquid/vapor separator **180** to other components within the liquefaction plant **102**).

[0061] In one embodiment, the storage tank **116** may be maintained at substantially the same pressure as that of the liquid/vapor separator **180**. By maintaining the liquid saturation pressure below associated transfer pressures, the liquid is prevented from boiling when the liquid experiences a pressure drop such as will occur when the liquid flows through piping, valves and other equipment as it is transferred from the liquid/vapor separator **180**. The pressure difference between the liquid/vapor separator **180** (e.g., approximately 50 psia) and a transfer pressure may be specified such that it is sufficient to ensure that any and all line pressure drops encountered en route to the storage tank **116** are accounted for. The liquid will then arrive at the storage tank **116** at saturation pressure, minimizing loss and flow complications that might otherwise occur due to boiling of the liquid during the transfer thereof.

[0062] As noted above, solid CO<sub>2</sub> mostly forms as small crystals in the liquid as it exits the JT valves **174** and **176**. With the appropriate resident time in the liquid, the CO<sub>2</sub> becomes a subcooled solid particle. In the subcooled state the particles are less likely to clump together. Keeping the particles suspended in the liquid provides more effective and efficient transfer and separation of the solids from the liquid component. If allowed to settle, the particles have a tendency to clump or stick together. To aid in keeping the CO<sub>2</sub> particles suspended in the liquid, gas bubbles may be introduced into the bottom of the liquid/vapor separator **180**. Introduction of the gas bubbles helps to agitate the CO<sub>2</sub> solids within the liquid and keep the particles continually moving within the liquid. While not specifically shown in FIG. 2, gas may be drawn from a suitable location within the liquefaction plant **102** where the gas stream exhibits a desired pressure and temperature and is introduced into the liquid/vapor separator **180** for bubbling through the slurry.

[0063] As the liquid/vapor separator **180** is filled, the level may be monitored by appropriate sensors. The level of the liquid/solid within the liquid/vapor separator **180** may be desirably monitored and controlled in order to provide desired resident times for the CO<sub>2</sub> and thereby ensure that the CO<sub>2</sub> particles are subcooled.

[0064] When a specified maximum level of liquid/solid slurry is reached within the liquid/vapor separator **180**, the liquid/solid slurry will be transferred to at least one of a plurality of transfer tanks **190A** and **190B**. In one embodiment, the transfer tanks **190A** and **190B** are used alternately. The transfer tanks **190A** and **190B** are utilized to transfer the slurry from the liquid/vapor separator **180** to one of a plurality of hydrocyclones **192A** and **192B**. While it is possible to transfer the slurry from the liquid/vapor separator **180** to the hydrocyclones **192A** and **192B** without the use of the transfer tanks **190A** and **190B**, it is believed that, in the currently described embodiment, the use of transfer tanks **190A** and **190B** provides improved control over the transfer of the slurry (including transfer of the slurry to the hydrocyclones **192A** and **192B** and subsequent transfer of the liquid from the hydrocyclones **192A** and **192B** to downstream components such as the storage tank **116**), and ensures that adequate transfer pressures are maintained during such transfer. If pressures are not properly maintained during transfer of the slurry, the liquid may boil due to pressure losses associated with piping and other components. Additionally, failure to maintain proper pressures during transfer of the slurry may result in inadequate solid-liquid separation. The use of separate, alternating transfer tanks **190A** and **190B** to effect the transfer of the slurry from the liquid/vapor separator **180** is one means that may be used to maintain the pressure integrity of the liquefaction plant **102**.

[0065] When the liquid/vapor separator **180** has reached its specified maximum level, two valves will open allowing the fluid to move into one of the transfer tanks (e.g., transfer tank **190A** for purposes of the present discussion). The first valve **220A** allows the transfer of liquid/CO<sub>2</sub> slurry, while the second valve **222A** vents the transfer tank **190A** back to the liquid/vapor separator **180** enabling the captured gases in the transfer tank **190A** to escape as it is being filled with the slurry. Depending, for example, on the length of the piping run between the liquid/vapor separator **180** and the transfer tank **190A**, bubbler locations may be added to the bottom of the pipe to prevent the CO<sub>2</sub> from settling during the transfer of the slurry (similar to that which has been previously described

with respect to the liquid/vapor separator **180**). It is noted that a single valve may be utilized instead of multiple valves if the single valve is properly located (e.g., physically below the liquid/vapor separator **180**).

[0066] When the level in the liquid/vapor separator **180** is reduced to a specified level, the first and second valves **220A** and **222A**, respectively, to the transfer tank **190A** close. The liquid/CO<sub>2</sub> transfer switches between the two transfer tanks **190A**, **190B** associated with the liquid/vapor separator **180**. Once the valves connecting the liquid/vapor separator **180** and transfer tank **190A** are closed, the liquid/CO<sub>2</sub> mixture is ready to be transferred to a hydrocyclone separator. The pressure-sensitive hydrocyclone separator separates the CO<sub>2</sub> from the liquid by cyclonic action. The transfer tank is pressurized to the desired pressure and the transfer valve is opened. The transfer pressure is approximately 20 psi higher than the saturation pressure of the liquid. This pressure head provides the motive force for the liquid/CO<sub>2</sub> mixture, prevents the liquid from boiling, as pressure drops are realized, and prevents the formation of additional CO<sub>2</sub> that could occur if the pressure were to drop below saturation pressure.

[0067] By alternating the filling of the two (or more) transfer tanks **190A** and **190B**, a constant flow of slurry to a selected hydrocyclone (e.g., hydrocyclone **192A**) may be easily maintained. The alternating use of transfer tanks **190A** and **190B** also improves the efficiency and effectiveness of the separation process performed by the hydrocyclones **192A** and **192B**. It is noted that, if the rate at which liquid is produced (i.e., within the liquid/vapor separator **180**) falls behind with respect to a desired separation rate of a hydrocyclone **192A**, the flow to the hydrocyclone **192A** may be suspended while the liquid/vapor separator **180** and transfer tanks **190A** and **190B** fill to a desired level. The transfer tanks **190A** and **190B** and hydrocyclones **192A** and **192B** may be oversized to prevent the possibility of producing liquid in the liquid/vapor separator **180** faster than the transfer/separation capabilities of the hydrocyclones **192A** and **192B**.

[0068] The transfer tank (considering transfer tank **190A** as an example) is pressurized by use of a pressure regulator **224**, which is set at a desired transfer pressure. If the feed line to the transfer tank **190A** is sufficient and the pressure regulator **224** is large enough, the pressure regulator **224** can be mounted directly on the transfer tank **190A**. This would require one pressure regulator **224** for each transfer tank **190A**, **190B**. However, in another embodiment, both transfer tanks **190A** and **190B** could be maintained with a smaller feed line and a single pressure regulator **224**, as shown in FIG. 2. Use of a single pressure regulator may require the use of storage or accumulator tanks (e.g., accumulator tanks **226A** and **226B**) to ensure that the proper volume of gas is used so as to maintain the pressure constant during the complete transfer process. It is noted that the gas used to transfer the liquid will be warmer than the liquid/solid slurry being transferred. As such, any heat transfer effects are accounted for in configuring and sizing the pressure regulator(s) **224** and accumulator tank(s) **226A** and **226B**.

[0069] As previously noted, the liquid/solid slurry is transferred to, and processed by, one of the hydrocyclones **192A** and **192B**. The hydrocyclones **192A** and **192B** act as separators to remove the solid CO<sub>2</sub> from the slurry allowing the LNG or other liquid product to be collected and stored. The hydrocyclones **192A** and **192B** may be configured to be substantially identical to one another. As such, only a single hydrocyclone **192A** is referenced with respect to the particu-

lar details thereof. In one embodiment, the hydrocyclone **192A** may be designed, for example, to operate at a pressure of approximately 215 psia at a temperature of approximately -228° F. The hydrocyclone **192A** uses a pressure drop to create a centrifugal force, which separates the solids from the liquid. A thickened slush, formed of a portion of the liquid natural gas with the solid CO<sub>2</sub>, exits the hydrocyclone **192A** through an underflow **194A**. The remainder of the liquid natural gas is passed through an overflow **196A** for additional filtering. A slight pressure differential, for example, between approximately 0.5 psid and 1.5 psid, exists between the underflow **194A** and the overflow **196A** of the hydrocyclone **192A**. The pressure in the hydrocyclone **192A** is provided and maintained by the transfer tank (transfer tank **190A** or **190B**). A control valve **240A** may be positioned at the overflow **196A** of the hydrocyclone **192A** to assist in controlling the pressure differential developed within the hydrocyclone **192A**. The underflow pressure may be controlled by the mid-system pressure as may be maintained by the suction side of a recompression compressor **228** (if one is being used) or by the distribution line pressure at the plant outlet **132**.

[0070] A suitable hydrocyclone **192A** may be configured to operate at design pressures of up to approximately 225 psig within a temperature range of approximately 100° F. to -300° F. Additionally, the hydrocyclone **192A** may desirably include an interior surface that is micro-polished to an extremely fine finish.

[0071] It is noted, that the hydrocyclones **192A** and **192B** are selectively coupled with each of the transfer tanks **190A** and **190B** through appropriate valving and piping, such that each of the transfer tanks **190A** and **190B** may selectively flow slurry to either of the hydrocyclones **192A** and **192B**. The use of two hydrocyclones **192A** and **192B** provides redundancy in the liquefaction system **100** so that if one hydrocyclone becomes plugged (or partially plugged), the other hydrocyclone may be used while appropriate maintenance is performed on the first. If desired, warm gas may be routed from another location in the liquefaction plant **102** to assist in unplugging a hydrocyclone such as by melting or sublimation of solid CO<sub>2</sub> that may be the source of any such plugging.

[0072] The liquid natural gas flows through the overflow **196A** of the hydrocyclone **192A** and may flow through one of a plurality of filters **200A** and **200B** placed in a parallel flow configuration. The filters **200A** and **200B** capture any remaining solid CO<sub>2</sub> which may not have been separated out in the hydrocyclone **192A**. The filters **200A** and **200B** may be configured such as substantially described in the U.S. priority patents and patent applications that have been incorporated herein by reference. Generally, in one embodiment, such filters **200A** and **200B** may include a first filter screen of coarse stainless steel mesh, a second conical shaped filter screen of stainless steel mesh less coarse than the first filter screen, and a third filter screen formed of fine stainless steel mesh. In another embodiment, all three filter screens may be formed of the same grade of mesh.

[0073] The filters **200A** and **200B** may, from time to time, become clogged or plugged with solid CO<sub>2</sub> captured therein. Thus, as one filter, i.e., filter **200A**, is being used to capture CO<sub>2</sub> (or other solids) from the liquid stream, the other filter, i.e., filter **200B**, may be purged of CO<sub>2</sub> by passing a relatively high temperature natural gas therethrough in a counter flowing fashion. For example, gas may be drawn from a relatively warmer gas stream, as indicated at connection point **202B** (or

connection point **202A** for filter **200A**) and connection point **202C** to flow through and clean the filter **200B**.

[0074] During cleaning of the filter **200B**, the cleaning gas may be discharged to a downstream location within the liquefaction plant **102** adjacent the second plant outlet **132** as indicated by interface connection **136E** (interface connection **136D** for filter **200A**) and interface connection **136A**. Appropriate valving and piping including, for example, three-way valves **204A** and **204B**, which may be used to enable the filters **200A** and **200B** to be switched and isolated from one another as may be required. Other methods of removing CO<sub>2</sub> solids (or other solids) that have accumulated in the filters **200A** and **200B** are readily known by those of ordinary skill in the art.

[0075] In another embodiment, the filters **200A** and **200B** may be configured to include a floating bed that traps solid CO<sub>2</sub> while permitting fluid to pass therethrough. As the floating bed becomes filled with CO<sub>2</sub>, the trapped CO<sub>2</sub> settles to the bottom. When the filter (e.g., filter **200A**) is filled with CO<sub>2</sub>, an elevated pressure differential develops indicating that the filter **200A** needs to be cleaned and flow can be switched to the redundant filter (e.g., filter **200B**). The first filter **200A** may then be cleaned in a manner similar to that which has been described hereinabove.

[0076] The filtered liquid passes from the filter **200A** (or filter **200B**) to a diversion tank **206**. Liquid in the diversion tank **206** may be selectively passed to the storage tank **116**, utilized for additional cooling within the liquefaction plant **102**, or both. When used for additional cooling, the liquid in the diversion tank **206** may be routed back to the heat exchanger **166**, such as through stream **208** and by use of an appropriate pump **210** (referred to herein as a diversion pump). The diversion pump **210** may also be used to elevate the pressure of the filtered liquid such that it may be subsequently reintroduced into the pipeline **104**. For example, a positive displacement pump may be used to pump liquid out of the diversion tank **206** to the heat exchanger **166** while increasing the pressure of the liquid to, for example, approximately 515 psia if the filtered liquid is going to be passed back to the pipeline **104** (or some other receiving line). By pressurizing the liquid to a distribution pressure, the load on the recompression compressor **228** is reduced, as it is more efficient to compress a liquid than it is to compress a gas.

[0077] The diversion tank **206** may also be supplied with liquid by way of a make-up pump **212** coupled with an outlet of the storage tank **116**. In the event of off normal or start-up conditions, where the liquefaction plant **102** is not supplying adequate liquid to keep the diversion tank **206** full, the make-up pump **212** may be used to supply the needed liquid. When the liquid level drops to a predetermined level within the diversion tank **206**, the make-up pump **212** will start and fill the diversion tank **206** back to a desired level. Thus, a supply of liquid may be maintained in the diversion tank **206** which may be pumped into the heat exchanger **166** to assist in preparing the liquefaction plant **102** for the liquid production process. In other words, the cryogenic liquid in the diversion tank **206** may be used provide cooling during in the final stages of the heat exchanger **166** in order to reduce the temperature of what becomes the compressed product stream **154"** to temperatures required for liquid production.

[0078] In one embodiment, the flow of liquid from the diversion tank **206** to the heat exchanger **166** may be controlled based on the temperature of the product stream **154"**. Thus, for example, as the temperature of the product stream

**154"** becomes warmer, the diversion pump **210** may provide additional flow of liquid from the diversion tank **206** to the heat exchanger **166**. Additionally, as the temperature of the product stream **154"** decreases, the diversion pump **210** may be controlled to reduce the amount of liquid being provided to the heat exchanger **166**. The diversion pump **210** may be configured as a variable flow pump and controlled, for example, by a proportional, integral, derivative (PID) controller.

[0079] Referring back to the hydrocyclones **192A** and **192B**, the thickened slush formed in the hydrocyclone (e.g., hydrocyclone **192A**) exits the underflow **194A** and passes through piping **212A** to a sublimation tank **214**. The sublimation tank **214** may include, for example, a heat exchanger configured to convert the solid CO<sub>2</sub> to a gaseous state.

[0080] In one particular embodiment, the sublimation tank **214** may include a tube-in-shell heat exchanger, such as that which is disclosed in the U.S. priority patents and patent applications previously incorporated herein by reference. The slush may enter such a heat exchanger on the tube side thereof. Relatively warm gas (i.e., relative to the temperature of the underflow **194A** of the hydrocyclone **192A**), for example, gas at a temperature of approximately  $-50^{\circ}$  F., may flow through the sublimation tank **214** by way of a flow path **216** from the heat exchanger **166**, or from some other location, to heat the slush and effect sublimation of the solid CO<sub>2</sub>.

[0081] It has been determined that, in natural gas mixtures found in conventional U.S. pipelines, CO<sub>2</sub> becomes a solid at approximately  $-160^{\circ}$  F. at approximately 35 psig. However, once the CO<sub>2</sub> has frozen, it no longer follows the phase change path it would when found in the natural gas mixture. Instead, the solid CO<sub>2</sub> acts as pure CO<sub>2</sub> which sublimates at approximately  $-80^{\circ}$  F. and at approximately 35 psig.

[0082] As the slush enters the sublimation tank **214**, the liquid carrier may violently flash to a gas which, in addition to transferring heat to the solid CO<sub>2</sub>, provides a positive motive flow for the solid CO<sub>2</sub>. Due to the turbulent nature of the flow, the CO<sub>2</sub> constantly interacts with tube walls as it progresses through the tubes. Additionally, the tube walls become progressively warmer along the flow path of the CO<sub>2</sub>. Once all of the liquid has flashed to a gas and warmed to approximately  $-80^{\circ}$  F., the CO<sub>2</sub> will start to sublime, aided by the relatively warm tube walls and the warmed gases. It is noted that the sublimation tank **214** may be configured such that the warm gas from flow path **216** will warm all areas of the shell (when configured as a tube-in-shell heat exchanger) to a temperature above the sublimation temperature of the CO<sub>2</sub>. In this manner, the sublimation tank **214** becomes "self-thawing" in the case of any potential plugs caused by the solid CO<sub>2</sub> passing through the tube side thereof.

[0083] The sublimed CO<sub>2</sub> leaves the sublimation tank **214**, passes through a portion of the heat exchanger **166**, combines with the expanded cooling stream **152'** as it also exits the heat exchanger **166** and passes through the second heat exchanger **159** prior to flowing through recompression compressor **228**. In other embodiments, the sublimed CO<sub>2</sub> may be combined with the expanded cooling stream **152'** at some other location (for example, prior to the expanded cooling stream **152'** entering the heat exchanger **166**). In yet other embodiments, the sublimed CO<sub>2</sub> may be combined with other streams or exit the liquefaction plant **102** from other locations depending, for example, on the site conditions and the operating conditions of the liquefaction plant **102**. The warming gas from flow path **216** exits the sublimation tank **214**, passes through the heat

exchanger **166**, and combines with the expanded cooling stream **152'** after the expanded cooling stream **152'** exits the second heat exchanger **159**.

[0084] As previously noted hereinabove, the liquefaction plant **102** may include a recompression compressor **228**. The recompression compressor **228** may be used to recompress gas to a desired pressure prior to reintroduction of the gas into the pipeline **104** (or other receiving station or system). Gas from the liquid/vapor separator **180** and from the storage tank **116** may be used, for example, as fuel for a combustion engine that drives the recompression compressor **228**.

[0085] It is noted that, while not specifically shown, a number of valves may be placed throughout the liquefaction plant **102** for various purposes such as facilitating physical assembly and start-up of the liquefaction plant **102**, maintenance activities, or for collecting of material samples at desired locations throughout the liquefaction plant **102** as will be appreciated by those of ordinary skill in the art.

[0086] It is further noted that the liquefaction plant **102** may be configured as a relatively compact structure such as described in the U.S. priority patents and patent applications previously incorporated herein by reference. Generally, the liquefaction plant **102** may be constructed on one or more skids for simple transportation and erection of the liquefaction plant **102**.

[0087] The liquefaction plant **102** may further include controls such that minimal operator input is required for the operation of the liquefaction plant **102**. Indeed, it may be desirable that the liquefaction plant **102** be able to function without an on-site operator. Thus, with proper programming and control design, the liquefaction plant **102** may be accessed through remote telemetry for monitoring and/or adjusting the operations of the liquefaction plant **102**. Similarly, various alarms may be built into such controls so as to alert a remote operator or to shut down the plant in an upset condition. One suitable controller, for example, may be a DL405 series programmable logic controller (PLC) commercially available from Automation Direct of Cumming, Ga.

[0088] Reviewing now the operation of the liquefaction plant **102** and considering various control aspects thereof, when the liquefaction plant **102** is started, the JT valves **174** and **176** are closed such that the product stream **154"** is diverted back into the heat exchanger **166** after passing through a JT valve **230**. This produces a cooling stream that may be used to cool the heat exchanger **166** until the temperature of the product stream **154"** approaches a desired temperature and pressure. When starting, the turbo expander **156**/compressor **158** system will be manually accelerated at a rate that corresponds with approximately 2° F. per minute temperature reduction in the heat exchanger **166**. This acceleration may stop when the pressure of the compressed process stream **154'** builds to the specified pressure. If the pressure of the pipeline **104** or other source is running at the specified pressure (e.g., approximately 740 psia), use of the compressor **158** may not be necessary. However, the compressor **158** may be started to provide a desired boost in pressure to the process stream **154**.

[0089] Prior to closing the JT valve **230** in the cooling stream and opening JT valves **174** and **176**, the diversion tank **206** may be filled with liquid from the storage tank **116**. The flow may simply fill the diversion tank **206** or it may recirculate back into the storage tank **116**. When the temperature of the product stream **154"** reaches a desired temperature, the flow of product stream **154"** is routed to the liquid/vapor

separator **180**. At this time, the diversion pump **210** will start pumping liquid from the diversion tank **206** to the heat exchanger **166** to aid in the final and rapid cooling of the compressed process stream **154'**.

[0090] Switching the flow of the product stream **154"** into the liquid/vapor separator **180** will prevent CO<sub>2</sub> from building up in the heat exchanger **166**. It is noted that CO<sub>2</sub> formation begins when the pressure drops from approximately 740 psia at a temperature of approximately -190° F. to -195° F. to a pressure of approximately 50 psia at a temperature of approximately -228° F. The initially warm tank of the liquid/vapor separator **180** will flash the small amount of liquid and CO<sub>2</sub> to a gas, as the temperature of the product stream **154"** decreases. Decreased temperatures in the product stream **154"** result in the production of additional liquid. The liquid quality will also improve as the temperature drops and the CO<sub>2</sub> will be suspended in the liquid as the tank of the liquid/vapor separator **180** cools to a point at which the liquid remains.

[0091] If the liquid/vapor separator **180** should fill before the temperature of the product stream **154"** is within the desired range, the liquid/vapor separator **180** may be flushed. Flushing the cold liquid into the warm transfer tanks **190A** and **190B** will boil off most of the liquid and any remaining liquid may be used to continue cooling off various components of the liquefaction plant **102**. As the temperature of the product stream **154"** reaches a desired range of, for example, approximately -180° F. to approximately -200° F., the turbo expander **156** will be slowly accelerated to a desired operational speed.

[0092] During operation of the liquefaction plant **102**, the temperature and pressure of the expanded cooling stream **152'** exiting the turbo expander **156** may be used as process control points. Such parameters may be managed to maximize the production of liquid. Generally, the expanded cooling stream **152'** should not be colder than the solidification temperature of CO<sub>2</sub>. Otherwise, plugging will result in the heat exchanger **166** or other components of the liquefaction plant **102**. In one embodiment, it is desirable to maintain the temperature of the expanded cooling stream **152'** as it enters the heat exchanger **166** in a range of approximately -150° F. to -157° F. at a pressure of approximately 50 psig to 250 psig and desirably at a pressure of approximately 185 psig.

[0093] During operation of the liquefaction plant **102**, the relationship between the "back-end flow loop" and the "cooling loop" may also be used as the basis for the liquid production and control of the liquefaction plant **102**. The back-end flow loop generally refers to the flow of fluid through the liquid handling components of the plant and particularly the flow through the valve or valves (e.g., JT valves **174** and **176**) leading into the liquid/vapor separator **180**. The cooling loop refers generally to the flow of fluid that provides cooling via the heat exchanger **166** during normal operating conditions and particularly includes the flow of liquid from the diversion tank **206**.

[0094] Specific control schemes regarding the relationship of the back-end flow loop and the cooling loop, as well as control schemes based on other relationships, are described in the various documents that have been incorporated by reference herein.

[0095] It is noted that various configurations of the liquefaction plant **102** may be utilized depending, for example, on site conditions and supply options. For example, referring to FIG. 3, and considering a two line site (i.e., a separate supply

line 104 and tail gas line 104A), four different general configurations are shown. Depending on the gas pressure in the supply line 104 and the tail gas line 104A, various combinations of pre-compression or post-compression may be used. Referring to a first configuration 250, the liquefaction plant 102 may be installed between the supply line 104 and the tail gas line 104A without any additional pre-compression or post-compression required. This scenario is a generally desirable scenario and may be implemented when the pressures of the gas in the supply line 104 and tail gas line 104A are at suitable pressures for operating the liquefaction plant 102.

[0096] A second configuration 252 includes a compressor 260 for pre-compression of the gas prior to entering the liquefaction plant 102. This configuration enables siting of the liquefaction plant 102 where the supply pressure is inadequate. However, the cost of the liquid product is increased as compared to the first configuration 250 due to the added pre-compression.

[0097] A third configuration 254 includes a compressor 262 for post-compression of the gas leaving the liquefaction plant 102. This configuration enables siting of the liquefaction plant 102 where the tail gas pressure is inadequate. The cost of the liquid product may be increased in the third configuration 254 as compared to the first configuration 252 due to the added post-compression depending, for example, on the specific pressures, flow rates and amount of post-compression required.

[0098] A fourth configuration 256 includes a compressor 260 for pre-compression of the gas entering the liquefaction plant 102, and a compressor 262 for post-compression of the gas leaving the liquefaction plant 102. This configuration enables siting of the liquefaction plant 102 where both the supply pressure and the tail gas pressure are inadequate. The cost of the liquid product may be increased in the fourth configuration 256 as compared to the other configurations 250, 252 and 254 due to the added pre- and post-compression. Of course, as noted hereinabove, depending on specific conditions and operating parameters, one of the configurations using pre- or post-compression may actually be more desirable.

[0099] Referring now to FIG. 4, options are shown for a single line site (i.e., where gas is drawn from and discharged into the same supply line 104). Depending on the supply pressure, and the pressure differential experienced by the liquefaction plant 102 (i.e., between inlet from and discharge to the supply line 104), various schemes of pre- and post-compression may be used. For example, compressors 260 and 262 may be used to both pre- and post-compression as set forth in the first configuration 270. In another embodiment, only one compressor 260 may be used for post-compression as indicated in configuration 272. In yet another embodiment, only one compressor 262 may be used for pre-compression as indicated in configuration 274.

[0100] By selecting a site based on the known pressures of supply lines and/or tail gas lines, and taking into account the operating pressures of the liquefaction plant 102, a significant increase in efficiency of the liquefaction plant 102 may be achieved with, for example, a reduction of required compression horsepower of up to, or more than, one half as compared to previously known designs.

#### Example

[0101] Referring now to FIGS. 2 and 5, an example of the process carried out in the liquefaction plant 102 is set forth. It

is noted that FIG. 5 is the same process flow diagram as FIG. 2, but with component reference numerals omitted for clarity. As the general process has been described above with reference to FIG. 2, the following example will set forth examples of conditions of the gas/liquid/slurry at various locations throughout the liquefaction plant 102, referred to herein as state points, according to the calculated operational design of the liquefaction plant 102. The following example is based on a configuration of a supply line having a pressure of approximately 600 psig, a tail gas line having a pressure of approximately 500 psig, using pre- and post-compression, with a design production of approximately 40,000 gallons of liquid per day at a saturation pressure of approximately 35 psig.

[0102] At state point 300, as the gas leaves the supply pipeline and enters the liquefaction plant 102, the gas will be approximately 60° F. at a pressure of approximately 615 psia with a flow of approximately 35,100 lbm/hr.

[0103] At state points 302 and 304, the flow will be split such that approximately 13,300 lbm/hr flows through state point 302 and approximately 21,800 lbm/hr flows through state point 304 with temperatures and pressures of each state point 302, 304 being similar to that of state point 300.

[0104] At state point 306, as the stream exits the turbo expander 156, the gas will be approximately -157° F. at a pressure of approximately 215 psia. At state point 308, as the gas exits the compressor 158, the gas will be approximately 102° F. at a pressure of approximately 740 psia.

[0105] At state point 308, after heat exchanger 153 and prior to the high-efficiency heat exchanger 166, the gas will be approximately 100° F. at a pressure of approximately 740 psia.

[0106] The gas exiting the high-efficiency heat exchanger 166, as shown at state point 312, will be approximately -190° F. at a pressure of approximately 740 psia.

[0107] At state point 314, after passing through the Joule-Thomson valves 174, 176, and prior to entering the liquid/vapor separator 180, the product stream 154" will become a mixture of gas, liquid natural gas, and the solid CO<sub>2</sub> and will be approximately -230° F. at a pressure of approximately 50 psia. The material will be in substantially the same state as it enters the transfer tanks 190A and 190B. The transfer tanks 190A and 190B will boost the pressure of the liquid slurry as may be required by the hydrocyclones 192A and 192B to achieve effective separation. The liquid temperature stays about the same (-230° F.) and becomes subcooled during this pressure boost.

[0108] At state point 316, after being separated via the hydrocyclone 192A, the liquid natural gas will be approximately -228° F. at a pressure of approximately 216 psia with a flow rate of approximately 9,003 lbm/hr. At state point 318, after flowing through a polishing filter 266A or 266B, the diversion tank 206, and the diversion pump 210, the temperature of the liquid natural gas will be approximately -226° F. and the pressure will be approximately 515 psia at a mass flow rate of approximately 3,205 lbm/hour.

[0109] At state point 320, as the liquid enters the storage vessel 116, the liquid will be at a temperature of approximately -230° F. with a pressure of approximately 50 psia at a mass flow rate of approximately 5,798 lbm/hr.

[0110] At state point 322 the thickened slush (including solid CO<sub>2</sub>) exiting the hydrocyclone 192A or 192B will be approximately -228° F. at a pressure of approximately -215 psia and will flow at a rate of approximately 1,737 lbm/hr.



[0111] At state point **324**, the gas exiting the liquid/vapor separator **180** will be approximately  $-230^{\circ}$  F. at a pressure of approximately 50 psia with a flow rate of approximately 2,561 lbm/hr.

[0112] At state point **326**, upon exiting the sublimation tank **214**, the temperature of the gas will be approximately  $-70^{\circ}$  F. and the pressure will be approximately 512 psia. The flow rate at state point **326** will be approximately 1,950 lbm/hr.

[0113] At state point **328**, and at the point of anticipated discharge from the liquefaction plant **102**, the gas will have a temperature of approximately  $277^{\circ}$  F. and a pressure of approximately 515 psia. The flow rate at state point **328** will be approximately 28,400 lbm/hr.

[0114] The liquefaction processes depicted and described herein with respect to the various embodiments provide for low cost, efficient and effective means of producing LNG.

[0115] It is noted that, while the invention has been disclosed primarily in terms of liquefaction of natural gas, the present invention may be utilized simply for removal of gas components, such as, for example,  $\text{CO}_2$  from a stream of relatively "dirty" gas. Additionally, other gases, such as for example, hydrogen, may be processed and other gas components, such as, for example, nitrogen, may be removed from a given feed gas. Thus, the present invention is not limited to the liquefaction of natural gas and the removal of  $\text{CO}_2$  therefrom.

[0116] While the invention may be susceptible to various modifications and alternative forms, specific embodiments have been shown by way of example in the drawings and have been described in detail herein. However, it should be understood that the invention is not intended to be limited to the particular forms disclosed. Rather, the invention includes all modifications, equivalents, and alternatives falling within the spirit and scope of the invention as defined by the following appended claims.

1. A method of liquefying a gas, the method comprising:  
liquefying at least a portion of a source gas to provide a liquid natural gas;  
precipitating a solid within the liquid natural gas; and  
separating the solid from the liquid natural gas.

2. The method of claim 1, further comprising subcooling the solid.

3. The method of claim 2, wherein precipitating a solid within the liquid natural gas comprises precipitating solid carbon dioxide within the liquid natural gas.

4. The method of claim 3, further comprising sublimating the solid carbon dioxide after separating the solid carbon dioxide from the liquid natural gas to form a gaseous carbon dioxide.

5. The method of claim 4, further comprising directing the gaseous carbon dioxide into a natural gas pipeline.

6. The method of claim 1, wherein liquefying at least a portion of the source gas to provide a liquid natural gas further comprises directing the source gas through at least one expansion valve.

7. The method of claim 1, further comprising bubbling and agitating the solid precipitate within the liquid natural gas.

8. The method of claim 1, wherein separating the solid from the liquid natural gas comprises directing a slurry comprising the solid and at least a portion of the liquid natural gas through a hydrocyclone.

9. A liquefaction plant comprising:

a product flow path defined and configured for delivery of a stream of gas through at least one expansion device and into a liquid-gas separator for producing a slurry of liquid natural gas and solid carbon dioxide from the at least a portion of a process stream within the liquid-gas separator; and

a hydrocyclone located and configured to receive a solid-liquid slurry from the liquid-gas separator.

10. The liquefaction plant of claim 9, further comprising a transfer tank located and configured to receive a solid-liquid slurry from the liquid-gas separator and deliver a solid-liquid slurry from the liquid-gas separator to the hydrocyclone.

11. The liquefaction plant of claim 10, further comprising an accumulator tank coupled to the transfer tank.

12. The liquefaction plant of claim 9, wherein the liquid-gas separator further comprises a gas bubbler.

13. The liquefaction plant of claim 9, further comprising a sublimation tank located and configured to receive and sublimate solid carbon dioxide from the hydrocyclone.

14. The liquefaction plant of claim 13, further comprising a compressor located and configured to compress carbon dioxide gas from the sublimation tank and direct compressed carbon dioxide gas into a natural gas pipeline.

\* \* \* \* \*