



US 20100183450A1

(19) **United States**

(12) **Patent Application Publication**
Schmidt

(10) **Pub. No.: US 2010/0183450 A1**

(43) **Pub. Date: Jul. 22, 2010**

(54) **STROKE-REGULATED LINEAR COMPRESSOR**

(30) **Foreign Application Priority Data**

Jul. 24, 2007 (DE) 10 2007 034 293.6

(75) Inventor: **Heinz Schmidt, Mohrendorf (DE)**

Publication Classification

Correspondence Address:
BSH HOME APPLIANCES CORPORATION
INTELLECTUAL PROPERTY DEPARTMENT
100 BOSCH BOULEVARD
NEW BERN, NC 28562 (US)

(51) **Int. Cl.**
F04B 49/00 (2006.01)
F04B 17/04 (2006.01)

(52) **U.S. Cl.** **417/212; 417/417**

(73) Assignee: **BSH BOSCH UND SIEMENS**
HAUSGERÄTE GMBH, Munich
(DE)

(57) **ABSTRACT**

(21) Appl. No.: **12/669,796**

A linear compressor having an electromagnet; an oscillating body movably guided in an oscillating fashion in the alternating field of the electromagnet; a cylinder; a piston connected to the oscillating body and movable back and forth inside the cylinder; a power supply circuit to supply the electromagnet with an alternating current; a proximity sensor to detect whether a distance between the piston and the end face of the cylinder falls below a predetermined threshold value; and a control circuit to detect a time period in which the distance between the piston and the end face of the cylinder falls below the threshold value and to regulate an amplitude and/or a phase of the alternating current if the time period deviates from a positive setpoint value.

(22) PCT Filed: **Jul. 9, 2008**

(86) PCT No.: **PCT/EP2008/058904**

§ 371 (c)(1),
(2), (4) Date: **Jan. 20, 2010**

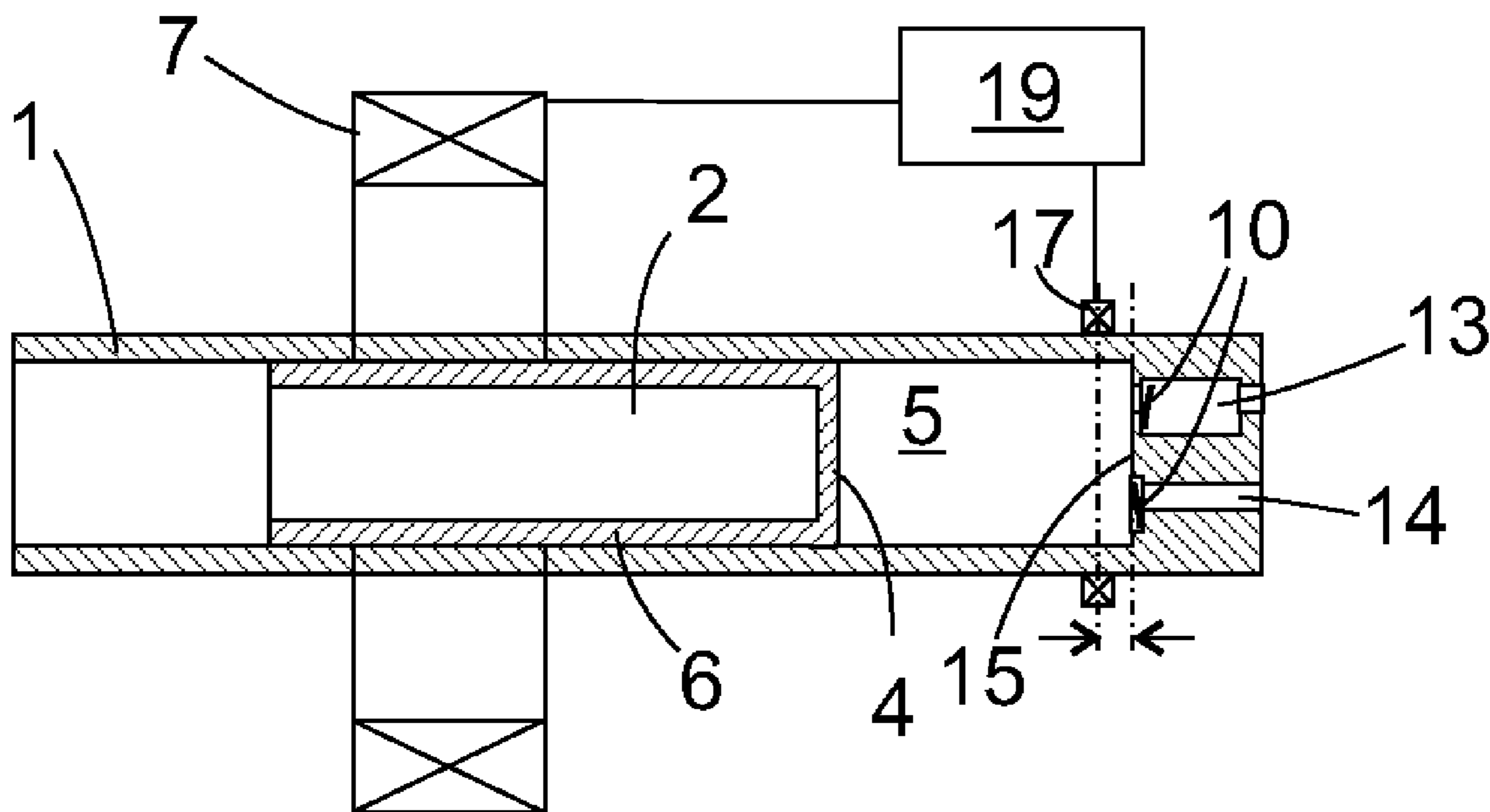

STROKE-REGULATED LINEAR COMPRESSOR

[0001] The present invention relates to a linear compressor, in particular for compressing refrigerant in a refrigeration appliance. Such a linear compressor conventionally comprises an electromagnet for generating a magnetic alternating field, an oscillating body, which is guided in such a manner that it can be moved back and forth in the field of the electromagnet and a piston that is coupled to the oscillating body and can be moved back and forth in a cylinder.

[0002] With a compressor with a piston driven by the rotation of a crankshaft the stroke of the piston movement is determined by the path diameter of a point, at which a piston rod engages on the crankshaft. The dead volume of the compressor can thus be made extremely small without any fear of the piston striking an opposing end side of the pump chamber. Minimizing the dead volume is important to achieve a high level of reliability of the compressor.

[0003] In the case of a linear compressor there is no such limiting of the piston stroke due to structure. The piston stroke can vary depending on the operating conditions of the compressor.

[0004] In order to operate a linear compressor with a small dead volume and in the process prevent the piston striking the opposing side of the pump chamber, which over time would lead to the destruction of the compressor, active regulation of the piston stroke is necessary. In the simplest instance it is possible to detect whether in the course of its movement the piston is less than a predetermined minimum distance from the opposing side at any time and if so, to regulate down the amplitude of the piston movement. The problem then arises that no information can be obtained about the amplitude of the piston movement, if it does not fall below the minimum distance from the opposing side and that although this minimum distance has to be small to allow operation with a small dead volume, the risk of the piston striking the opposing side of the cylinder when it is at less than the minimum distance is greater, the smaller the minimum distance is set to be.

[0005] It is also possible to monitor the position of the piston continuously during the course of its movement, in order to know the amplitude of the oscillating movement at all times, regardless of whether or not it falls below a minimum distance. Such continuous monitoring and the processing of the monitoring results require a high apparatus outlay however, making such a compressor expensive.

[0006] The object of the present invention is to create a linear compressor, which makes it possible with simple, economical means to operate the compressor with a high level of efficiency and to prevent the piston striking an opposing end side in a reliable manner.

[0007] The object is achieved in that in the case of a linear compressor having at least one electromagnet, at least one oscillating body movably guided in an oscillating fashion in an alternating field of the electromagnet, at least one piston that is connected to the oscillating body and movable back and forth inside a cylinder and a power supply circuit for supplying the electromagnet with an alternating current, a proximity sensor detects whether or not the distance between the piston and an end face of the cylinder falls below a threshold value and a control circuit detects a time period, in which the distance between the piston and the end face falls below

the threshold value and regulates the amplitude and/or phase of the alternating current if this time period deviates from a positive setpoint value.

[0008] This invention is based on the knowledge that the time period in which the distance is below the threshold value is uniquely related to the amplitude of the piston movement. In other words it is sufficient to know this time period in order to be able to calculate the amplitude. Conversely, if the maximum possible amplitude of the piston, in other words the distance between the piston and the end face of the cylinder in an equilibrium position of the piston, the threshold value for the distance between the piston and the end face and the oscillation period of the piston are predetermined, it is possible to specify a setpoint value for the time period for which the distance falls below the distance threshold value, which corresponds to a desired amplitude of the piston movement. In other words a suitable selection of the time period allows the piston movement to be regulated so that it may fall below the threshold value of the distance but the piston is however certain not to strike the end face.

[0009] To prevent the piston striking the end face of the cylinder, the setpoint value Δt_{soll} should be less than

$$\frac{T}{\pi} \cos^{-1} \frac{2(L - \epsilon)}{L}$$

where ϵ is the threshold value of the distance between the piston and the end face, T is the oscillation period of the oscillating body or the piston and L is the distance between the end face and the piston in a rest position of the piston.

[0010] The smaller the setpoint value Δt_{soll} , the greater the degree to which the time period Δt , in which the distance falls below the threshold value ϵ , reacts to a change in the oscillation amplitude, i.e. the more precisely it is possible to regulate the oscillation amplitude. The setpoint value Δt_{soll} is therefore preferably less than 0.15 T .

[0011] On the other hand the setpoint value $Dtsoll$ should also not be too near to 0, as otherwise if there is a minor reduction of the oscillation amplitude, a drop below the threshold value ϵ is no longer detected and it is therefore no longer possible to measure the amplitude. The setpoint value Δt_{soll} should therefore be preferably selected to be greater than 0.02 T .

[0012] Corresponding considerations apply to the threshold value ϵ itself. On the one hand this should be small, to allow a precise conclusion to be drawn about the amplitude of the piston movement. The threshold value is therefore preferably selected to be smaller than $1/10$ of the distance between the end face and the piston in a rest position of the piston.

[0013] On the other hand too small a value of ϵ means that in some circumstances an increase in the oscillation amplitude cannot be countered promptly and the piston strikes the end face. The threshold value ϵ is therefore preferably greater than $1/50$ of the abovementioned distance.

[0014] In order not to influence the piston movement a contactless sensor is preferably used as the proximity sensor, in particular an inductive switch.

[0015] Further features of the invention will emerge from the description which follows of exemplary embodiments with reference to the accompanying figures, in which:

[0016] FIG. 1 shows a schematic section through a linear compressor according to a first embodiment of the invention;

[0017] FIG. 2 shows the temporal profile of the piston movement and a proximity sensor signal derived therefrom;

[0018] FIG. 3 shows the relationship between the duty factor of the proximity sensor signal and amplitude of the piston movement; and

[0019] FIG. 4 shows a similar section to the one in FIG. 1 through a linear compressor according to a second embodiment of the invention.

[0020] The linear compressor shown in FIG. 1 comprises a cylindrical pipe 1, which is closed off at one end by an end face 15, and a piston 2 held movably in an oscillating fashion in the pipe 1. The piston 2 is configured as beaker-shaped, with a base of the beaker forming an end side 4 of the piston facing the end face 15. A wall 6 of the beaker is formed at least partially by a permanent magnet, which interacts with a magnetic alternating field generated by a coil 7 to drive the back and forth movement of the piston 2. The coil 7 is shown here by way of example as an annular coil extending around the pipe 1; various other coil arrangements are known in the field of the linear compressor and are also suitable within the context of the present invention. Coil arrangements are also possible, which can drive the piston 2 even if it is only made of a ferromagnetic and not permanently magnetized material.

[0021] Extending through the end face 15 and provided respectively with nonreturn valves 10 are an inlet 14 and an outlet 13 for a gas to be compressed, e.g. a refrigerant, if the compressor is employed in a refrigeration unit, in particular a domestic refrigeration appliance.

[0022] An inductive proximity switch 17 is formed here by a coil positioned tightly around the pipe 1 which is made of a non-ferromagnetic material. The proximity switch 17 is disposed a short distance from the end face 15, in order to detect the end side 4 of the piston 2 as soon and as long as its distance from the end face 15 falls below a threshold value ϵ determined by the positioning of the proximity switch 17. The output signal of the proximity switch 17 is thus a sequence of rectangular pulses, the period of which corresponds to the period of the piston movement, the duration Δt_{ON} of each pulse representing the time period in which the distance falls below the threshold value ϵ .

[0023] Other types of proximity switch can also be used in the context of the invention; for example in particular if the piston of the compressor of an oscillating body interacting with the magnetic alternating field of the coil is not fused in a component, as shown in FIG. 1, but the oscillating body is disposed outside the pipe 1 and connected to the piston, a light barrier, which detects part of the oscillating body, can serve as the proximity switch.

[0024] A control circuit 19 receives the output signal of the proximity switch 17 and uses this output signal, as described in more detail below, to regulate an alternating current, which it applies to the coil 7.

[0025] FIG. 2 shows the temporal profile of the movement of the piston 2 and the resulting output signal of the proximity switch 17. Time is plotted on the abscissa of the diagram with the deflection of the piston in relation to an equilibrium position shown as 0 on the left ordinate and the output signal level of the proximity switch 17 on the right ordinate. The movement of the piston follows a cosine curve 18. When the piston 2 is in the equilibrium position, the distance between the piston 2 and the end face 15 is 1 cm; in other words the maximum amplitude of the piston movement is 2 cm. A broken line at a distance x_S of 0.95 cm corresponds to the detection threshold of the proximity switch 17; if the piston 2

is beyond this threshold, the output signal of the proximity switch 17 has the value 1; otherwise it is 0. It can be seen that the following applies for the amplitude 1_{hub} of a harmonic oscillation:

$$l_{Hub} = 2 \frac{x_S}{\cos\left(\pi \frac{t_{Ein}}{T}\right)} \quad (1)$$

where t_{ON} is the duration of a pulse of the output signal of the proximity switch 17 and T is the period of the piston movement.

[0026] If we assume that 1_{hub} should be smaller than the maximum amplitude L (here L=2 cm) of the piston movement, at which the piston 2 touches the end face 15 at the reversal point of its movement, the following requirement results from the above formula for the pulse duration t_{ON} of the output signal of the proximity switch 17

$$t_{Ein} < \frac{T}{\pi} \cos^{-1} \frac{2(L - \epsilon)}{L}. \quad (2)$$

[0027] The relationship between the duty factor t_{ON}/T of the proximity switch output signal and the associated oscillation amplitude of the piston 2 is shown in FIG. 3. An upper region of the diagram above an amplitude of 2 cm is shown hatched, to indicate that this region in practice must not be reached, as otherwise the piston 2 would strike the end face 15. If the amplitude of the oscillation is smaller than $2x_S=1.9$ cm, the proximity switch 17 does not respond and the duty factor is 0. Permissible values of the duty factor are thus in an range from 0 to 0.1.

[0028] It can be seen that for an oscillation amplitude just over $2x_S$ the duty factor t_{ON}/T varies very significantly with amplitude, while the dependency of the duty factor t_{ON}/T on amplitude decreases toward larger amplitudes. In other words the most precise amplitude measurement is possible, if it is just above the detection threshold of $2x_S$. It is therefore expedient to make the distance ϵ between the detection threshold of the proximity switch 17 and the end face 15 small, in the present instance 0.05 cm. The duty factor can then as a maximum reach the value 0.1; the closer to this value the compressor is operated, the higher its level of efficiency but the higher also the risk of the piston 2 striking the end face 15 due to an unforeseen amplitude fluctuation. To avoid this, the control circuit 19 regulates the amplitude and/or period of an alternating current fed into the coil 7 based on the output signal of the proximity switch 17 and a predetermined setpoint value for the duty factor of this output signal, which is between 0 and 0.1, for example around 0.05 here. If the control circuit 19 determines that the duty factor exceeds the setpoint value, it reduces the amplitude of the alternating current fed into the coil 7 or pulls its frequency toward the resonant frequency of the piston 2, in order thus to reduce its movement amplitude. If the duty factor is below the setpoint value, it increases the amplitude of the alternating current or reduces the deviation between its frequency and the resonant frequency of the piston 2, to produce more efficient oscillation excitation.

[0029] As shown in FIG. 4, the principle of the invention can also be applied to a linear compressor with two pistons 2_1 , 2_2 , moved in a counter-rotating manner. With the arrangement shown here the longitudinal ends of the cylindrical pipe 1

respectively form inlets **14** for gas to be compressed and gas passes through valves **9** formed in the end faces **4** of the opposing pistons **2₁**, **2_r**, into the pump chamber **5** bounded by the pipe **1** and the pistons **2₁**, **2_r**. Holes **11** run in a center plane, shown as a broken line, through the wall of the pipe **1** and lead to an outlet **13**.

[0030] With this embodiment the end side **4** of one of the pistons **2₁**, **2_r** corresponds respectively to the end face **15** of the compressor in FIG. 1, which the end side **4** of the respective other piston **2_r**, **2₁** must not strike. To monitor piston movement proximity switches **17₁**, **17_r** are disposed on both sides of the center plane at a distance ϵ from it. A control circuit **19** applies alternating currents I_1 , I_r with mutually identical phases to each coil **7₁**, **7_r**. In this process it regulates the amplitude of each alternating current I_1 , I_r as described above based on the duty factor t_{ON}/T of the output signal of the respectively assigned proximity switch **17₁**, **17_r**. Regulating the oscillation amplitudes of both pistons **2₁**, **2_r** such that they just fail to reach the center plane allows reliable operation with a high level of efficiency.

1-8. (canceled)

9. A linear compressor, comprising:
 an electromagnet having an alternating field;
 an oscillating body movably guided in an oscillating fashion in the alternating field of the electromagnet;
 a cylinder having an end face;
 a piston connected to the oscillating body and movable back and forth inside the cylinder;
 a power supply circuit to supply the electromagnet with an alternating current;
 a proximity sensor to detect whether a distance between the piston and the end face of the cylinder falls below a predetermined threshold value; and
 a control circuit to detect a time period in which the distance between the piston and the end face of the cylinder

falls below the predetermined threshold value and to regulate at least one of an amplitude and a phase of the alternating current if the time period deviates from a positive setpoint value.

10. The linear compressor of claim **9**, wherein the setpoint value is smaller than

$$\frac{T}{\pi} \cos^{-1} \frac{2(L - \epsilon)}{L},$$

wherein ϵ is the predetermined threshold value, T is an oscillation period of the piston and L is the distance between the end face of the cylinder and the piston in a rest position of the piston.

11. The linear compressor of claim **10**, wherein the setpoint value is smaller than $0.15 T$.

12. The linear compressor of claim **10**, wherein the setpoint value is greater than $0.02 T$.

13. The linear compressor of claim **9**, wherein the predetermined threshold value is smaller than a tenth of the distance between the end face of the cylinder and the piston in a rest position of the piston.

14. The linear compressor of claim **9**, wherein the predetermined threshold value is greater than a fiftieth of the distance between the end face and the piston in a rest position of the piston.

15. The linear compressor of claim **9**, wherein the proximity sensor is a contactless sensor.

16. The linear compressor as claimed in claim **15**, wherein the proximity sensor is an inductive switch.

* * * * *