



(19) **United States**

(12) **Patent Application Publication**  
**SMITH**

(10) **Pub. No.: US 2010/0155043 A1**

(43) **Pub. Date: Jun. 24, 2010**

(54) **ELEMENT FOR EMISSION OF THERMAL RADIATION**

(75) Inventor: **Geoffrey Burton SMITH**, Epping (AU)

Correspondence Address:  
**NIXON & VANDERHYE, PC**  
**901 NORTH GLEBE ROAD, 11TH FLOOR**  
**ARLINGTON, VA 22203 (US)**

(73) Assignee: **University of Technology**, Sydney (AU)

(21) Appl. No.: **12/644,985**

(22) Filed: **Dec. 22, 2009**

**Related U.S. Application Data**

(63) Continuation-in-part of application No. PCT/AU2008/000892, filed on Jun. 19, 2008, Continuation-in-part of application No. PCT/AU2008/000893, filed on Jun. 19, 2008.

(30) **Foreign Application Priority Data**

Jun. 19, 2007 (AU) ..... 2007202832

Sep. 28, 2007 (AU) ..... 2007221733

**Publication Classification**

(51) **Int. Cl.**  
**F28F 7/00** (2006.01)

(52) **U.S. Cl.** ..... **165/185**

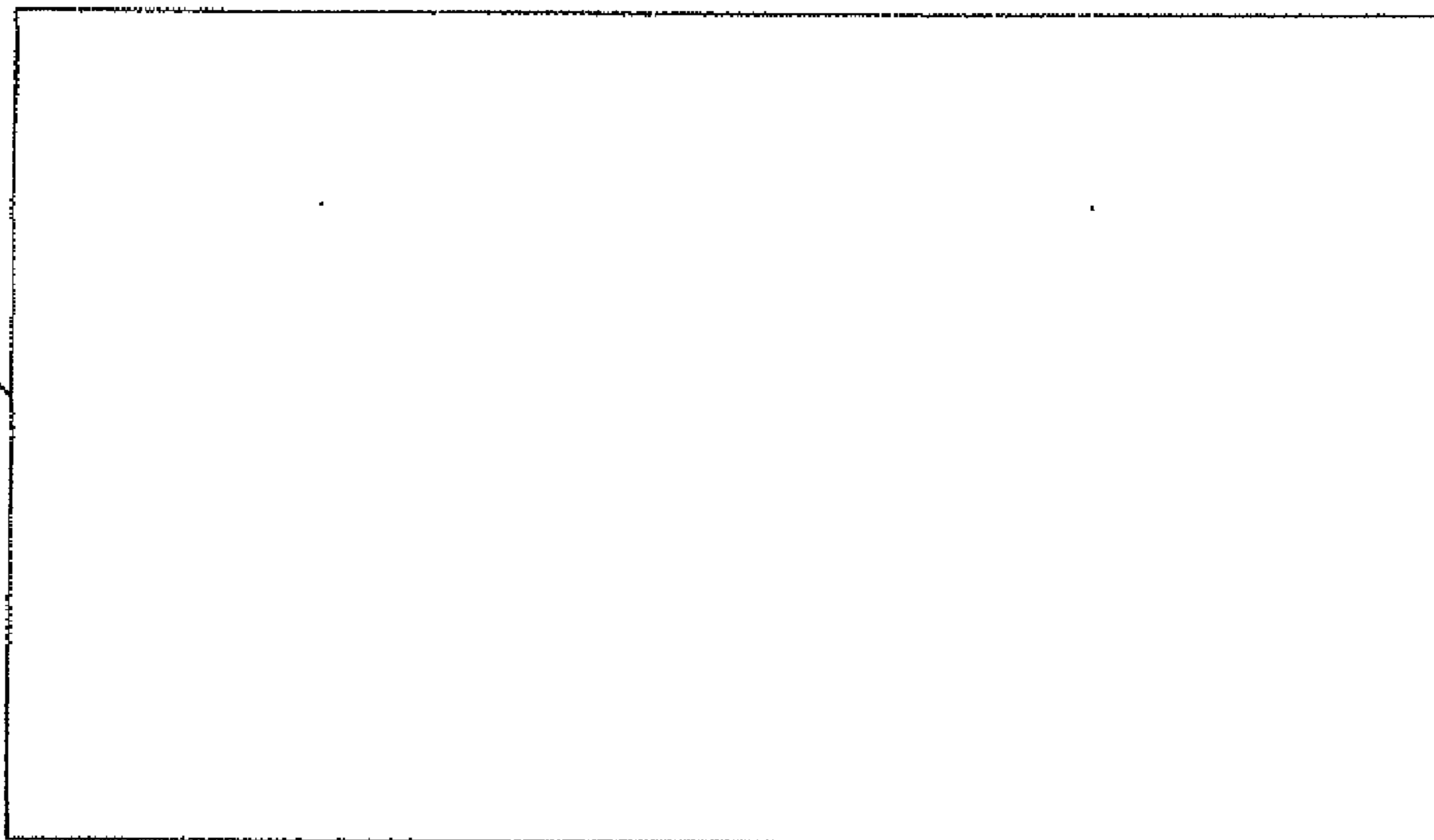
(57) **ABSTRACT**

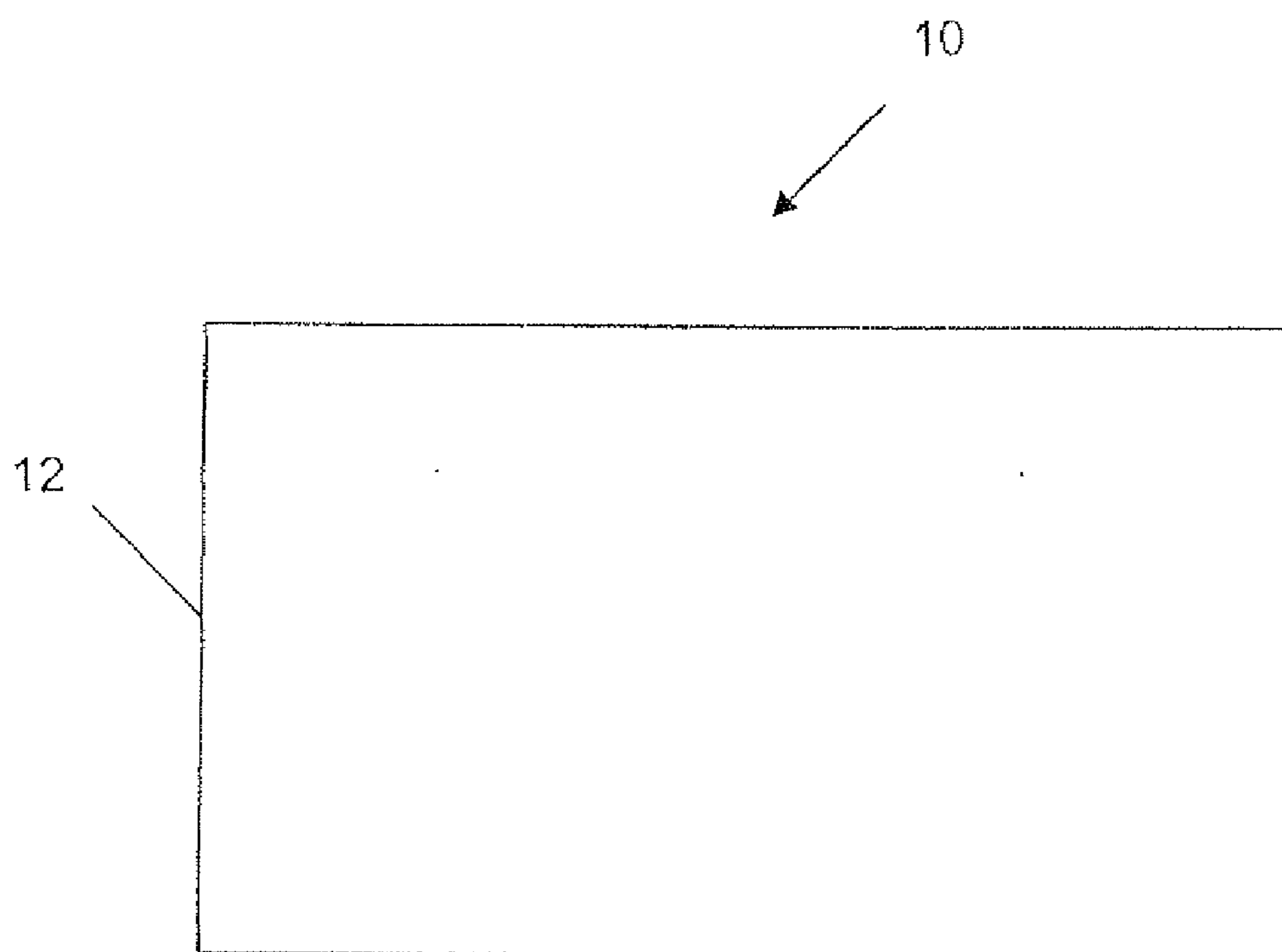
The present disclosure provides an element for emission of thermal radiation. The element comprises particles arranged for receiving thermal energy and emitting at least a portion of the received thermal energy in the form of the thermal radiation. The thermal radiation predominantly has a wavelength or wavelength range within an atmospheric window wavelength range in which the atmosphere of the Earth has a reduced average absorption and emission compared with an average absorption and emission in an adjacent wavelength range whereby absorption by the element of radiation from the atmosphere is reduced.

10

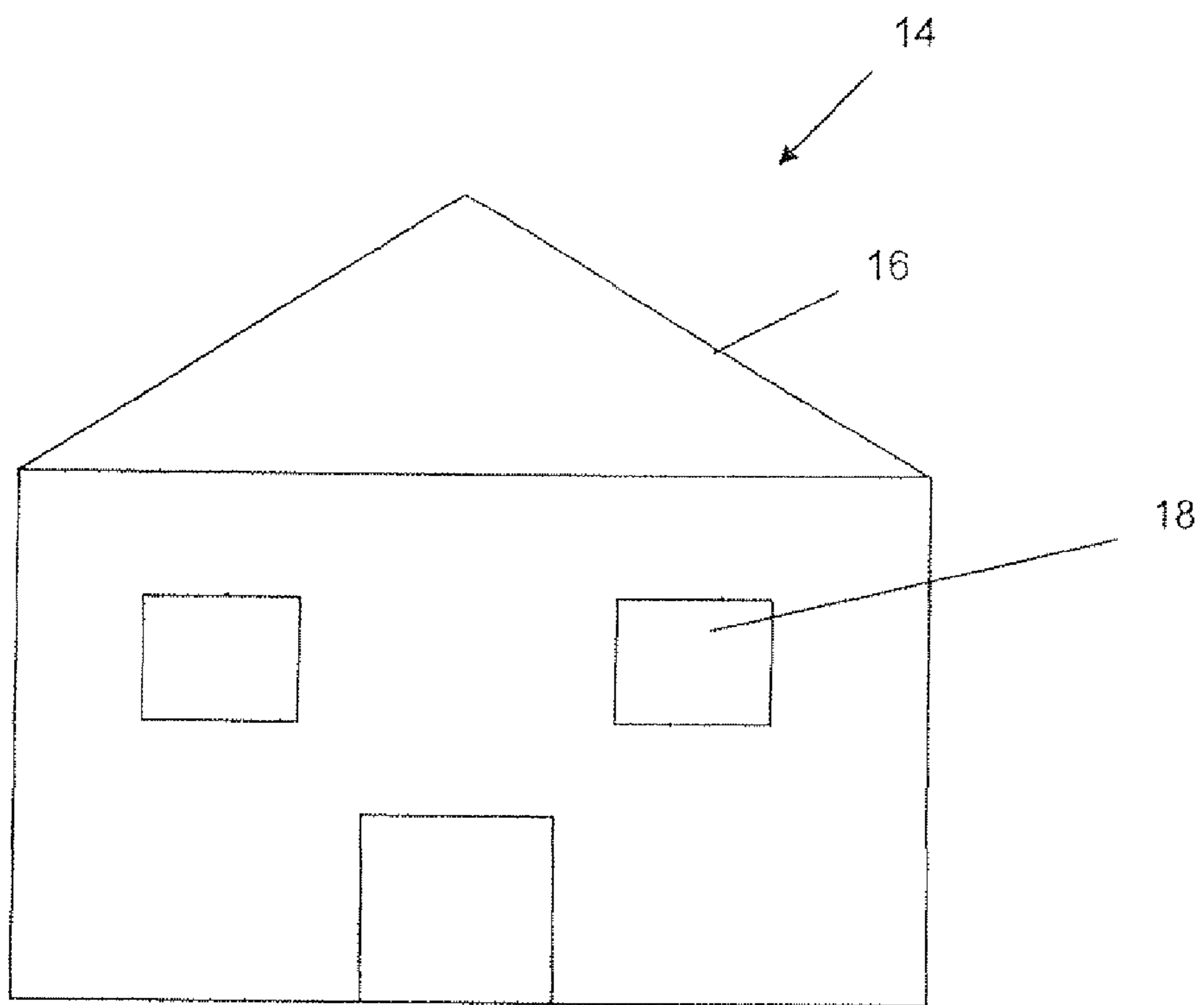


12

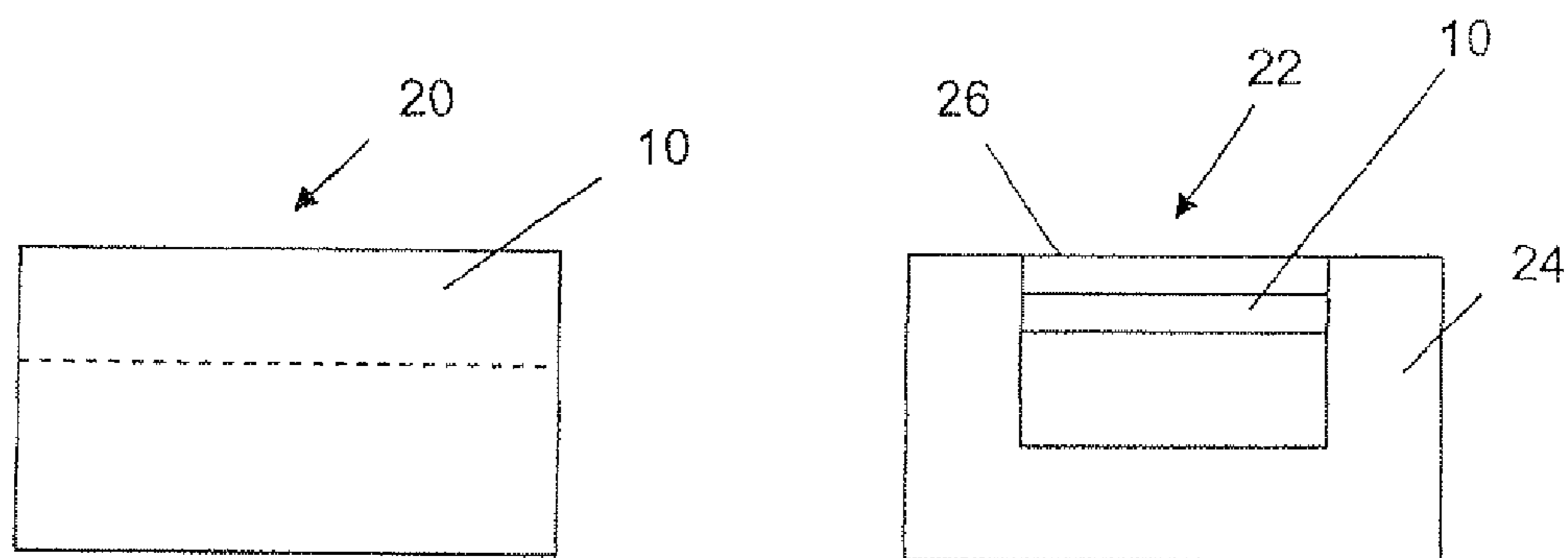




*Fig. 1*

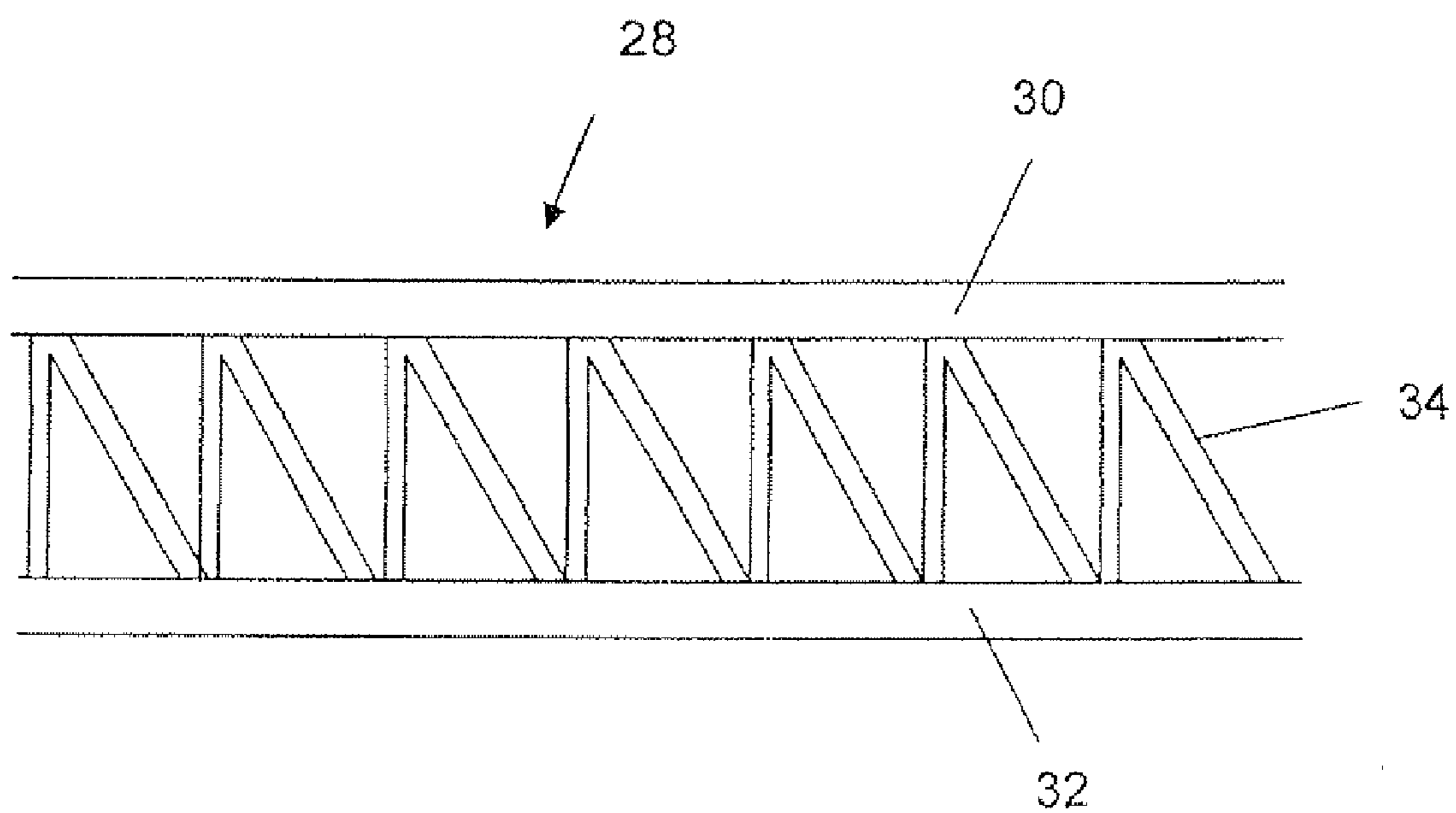


**Fig. 2**

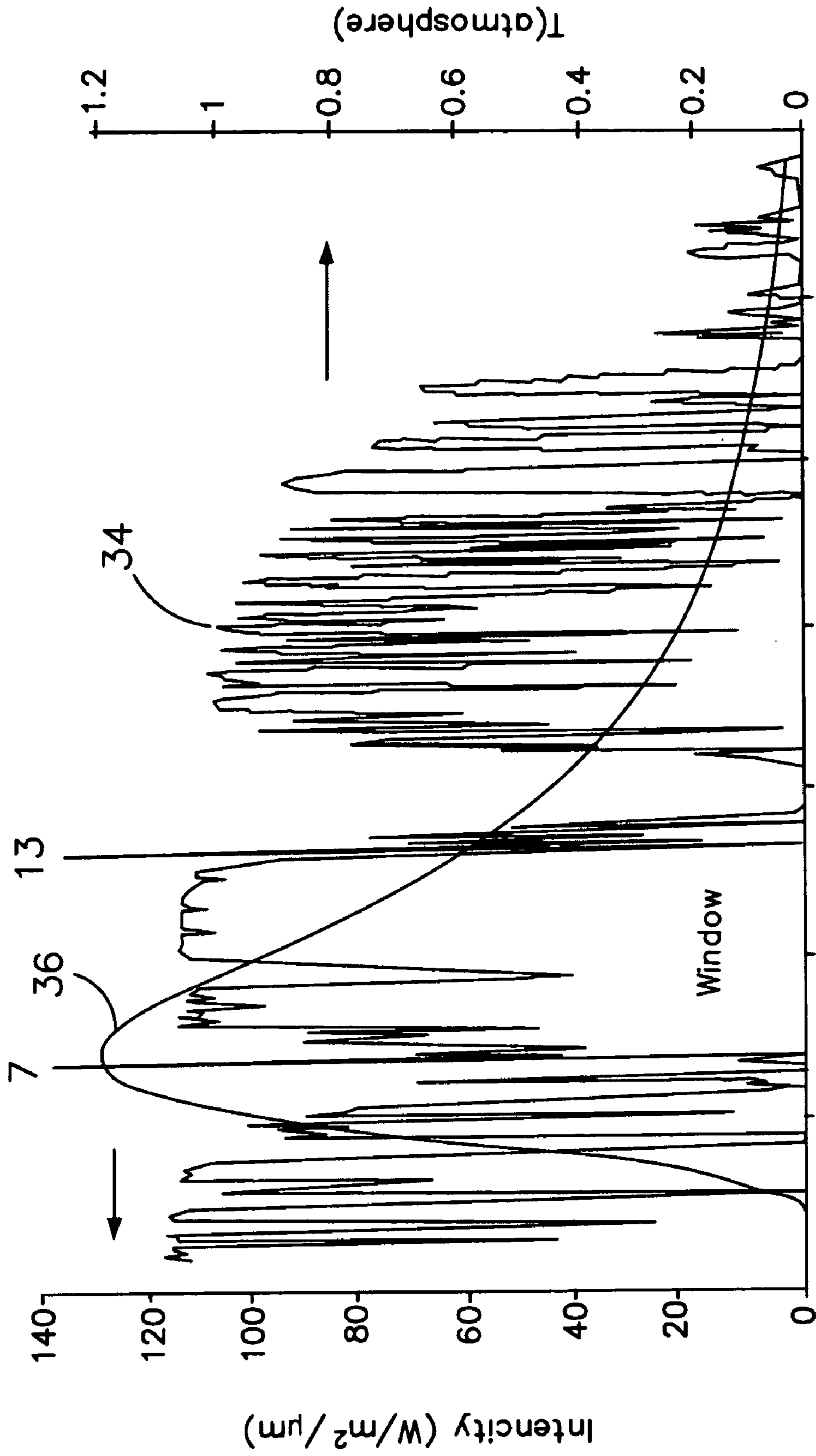


**Fig. 3 (a)**

**Fig. 3 (b)**



**Fig. 4**



Wavelength (microns)

Fig. 5



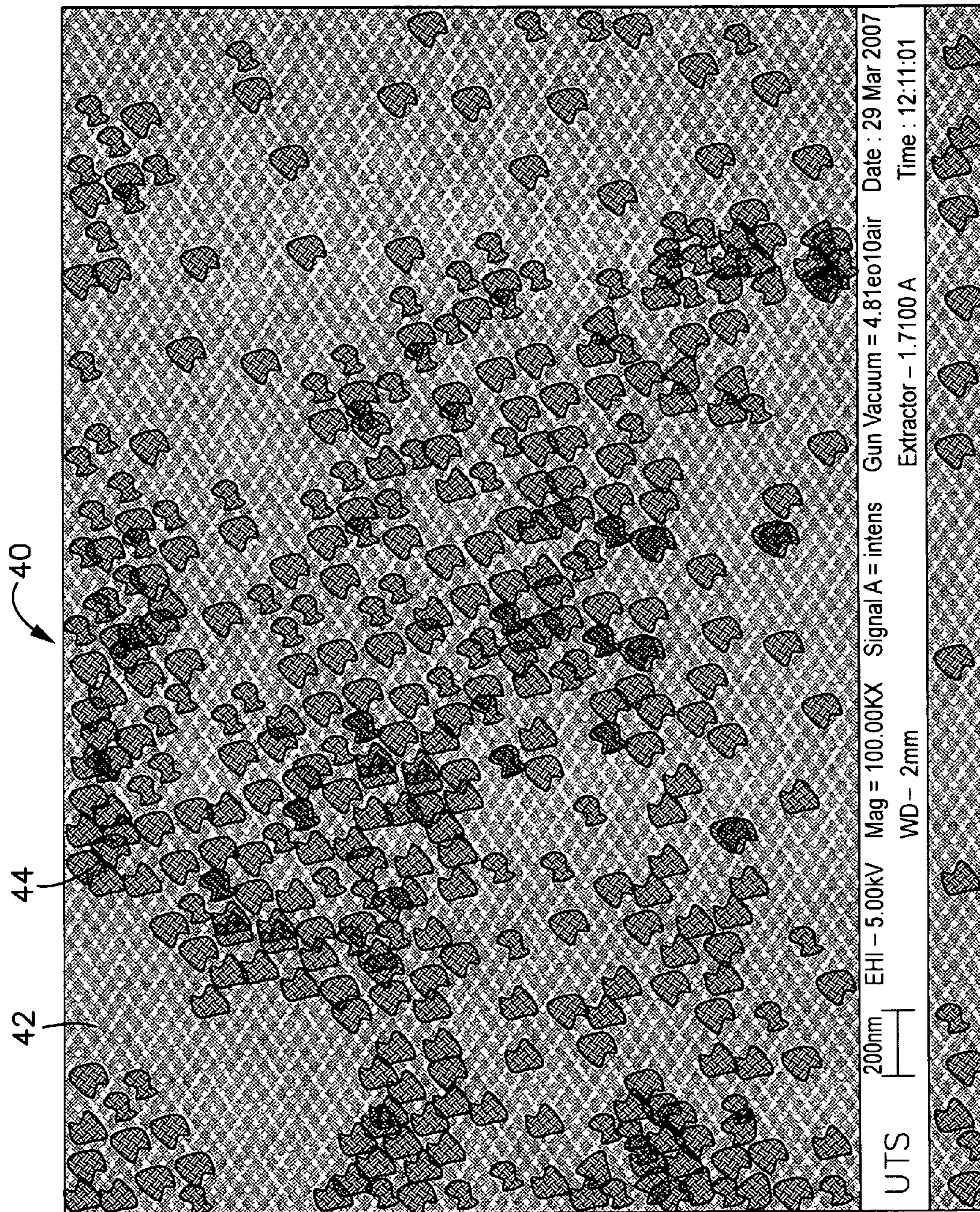
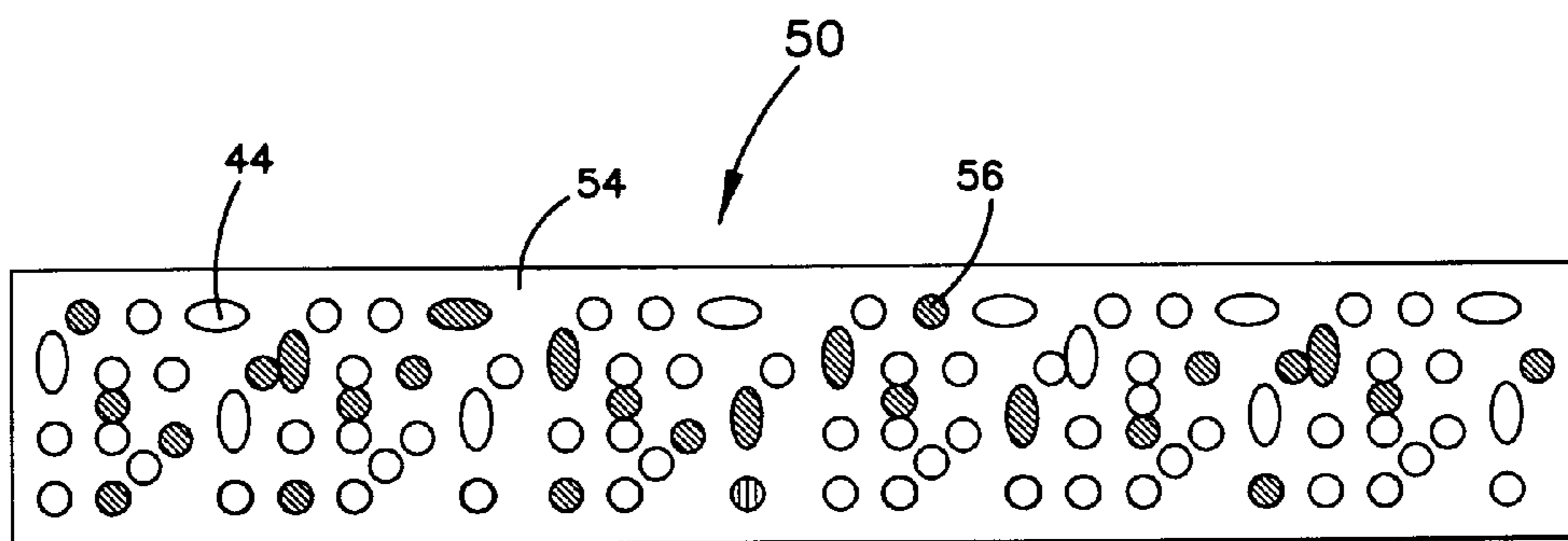
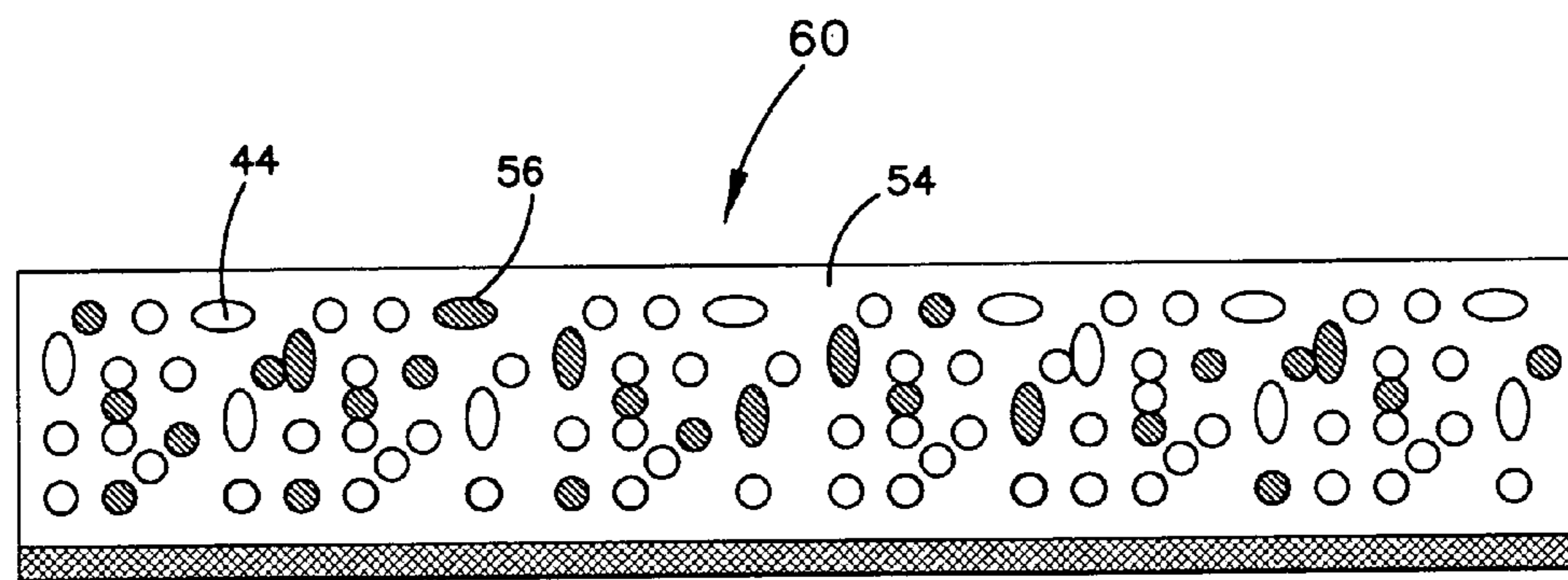


Fig. 6



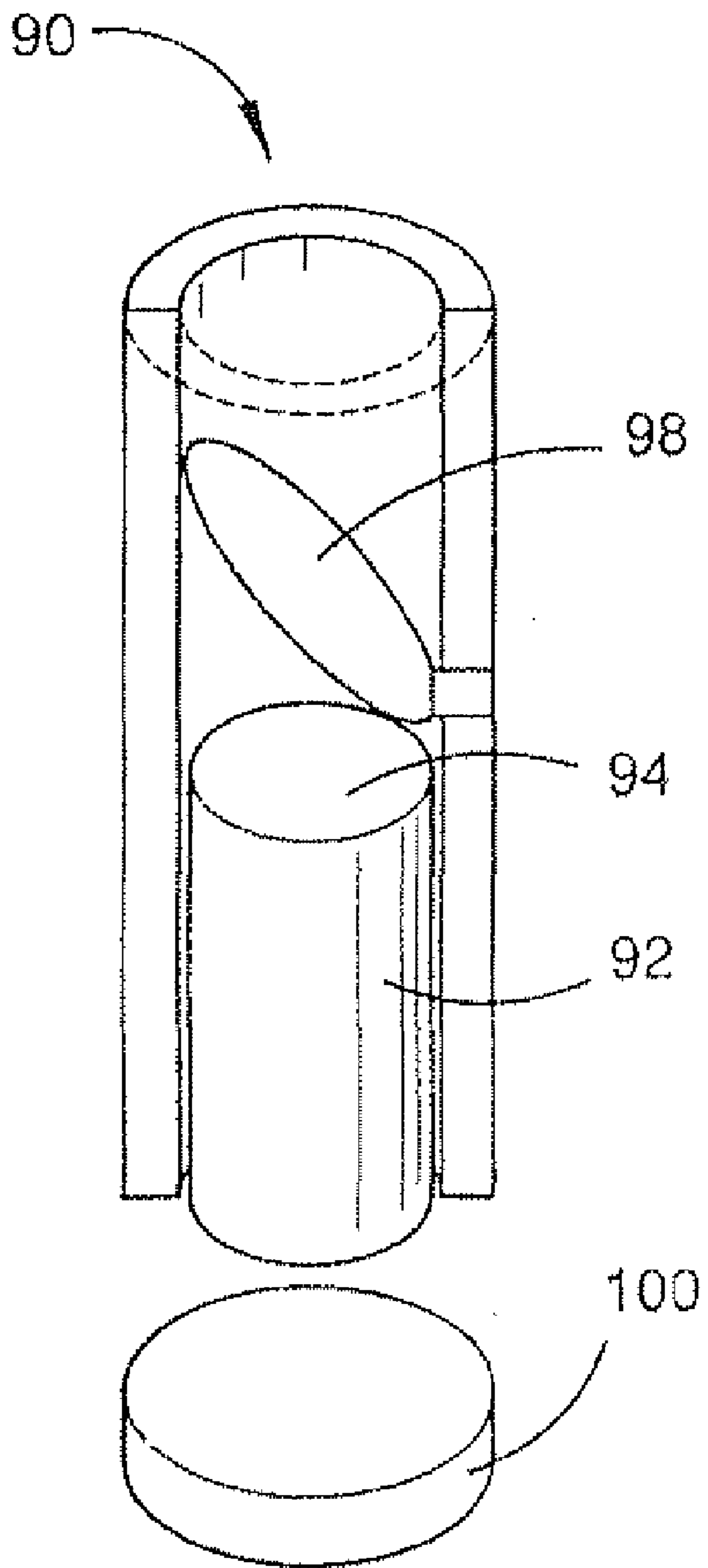


**Fig. 7**



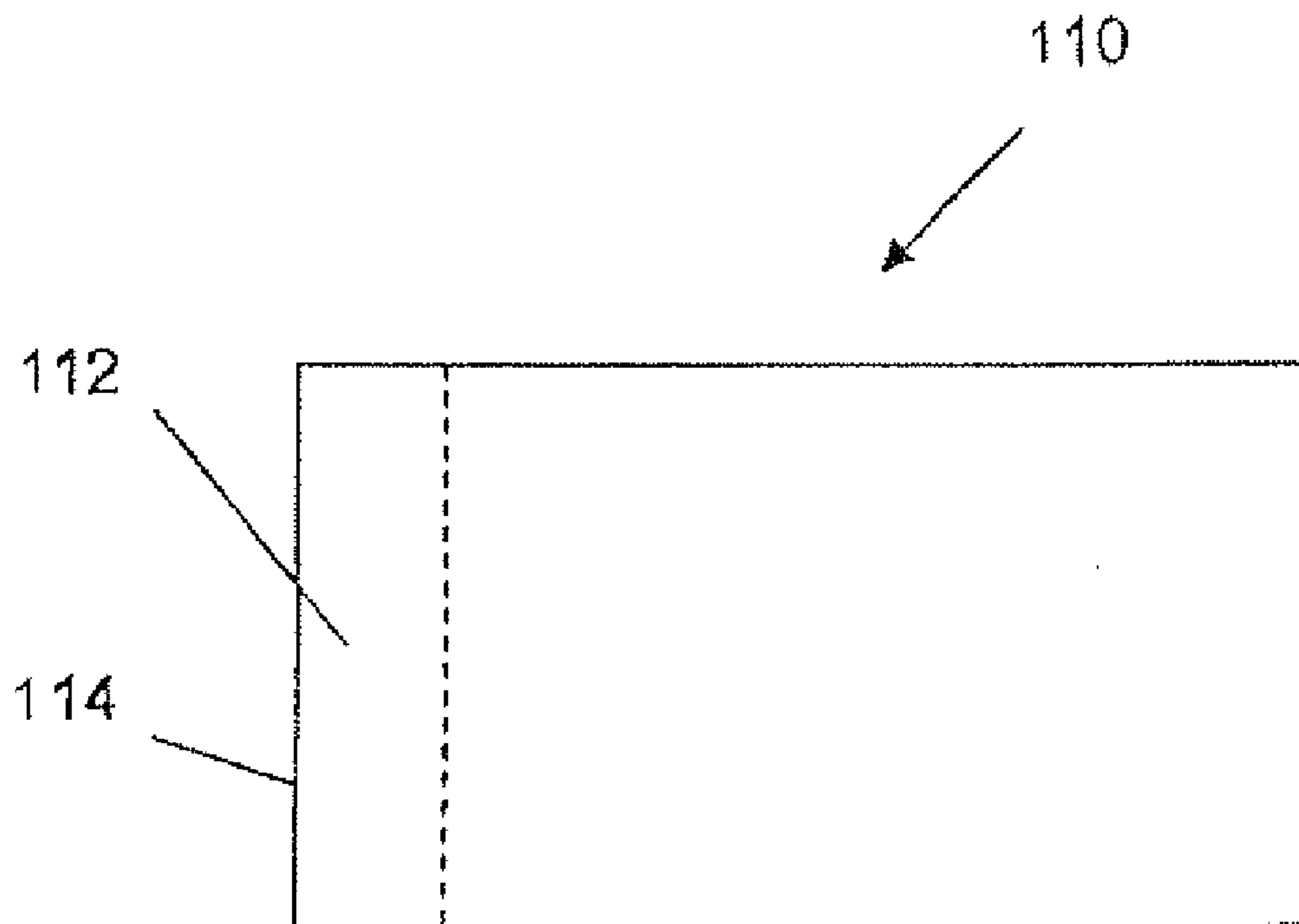
**Fig. 8**

42



**Fig. 9**





*Fig. 10*

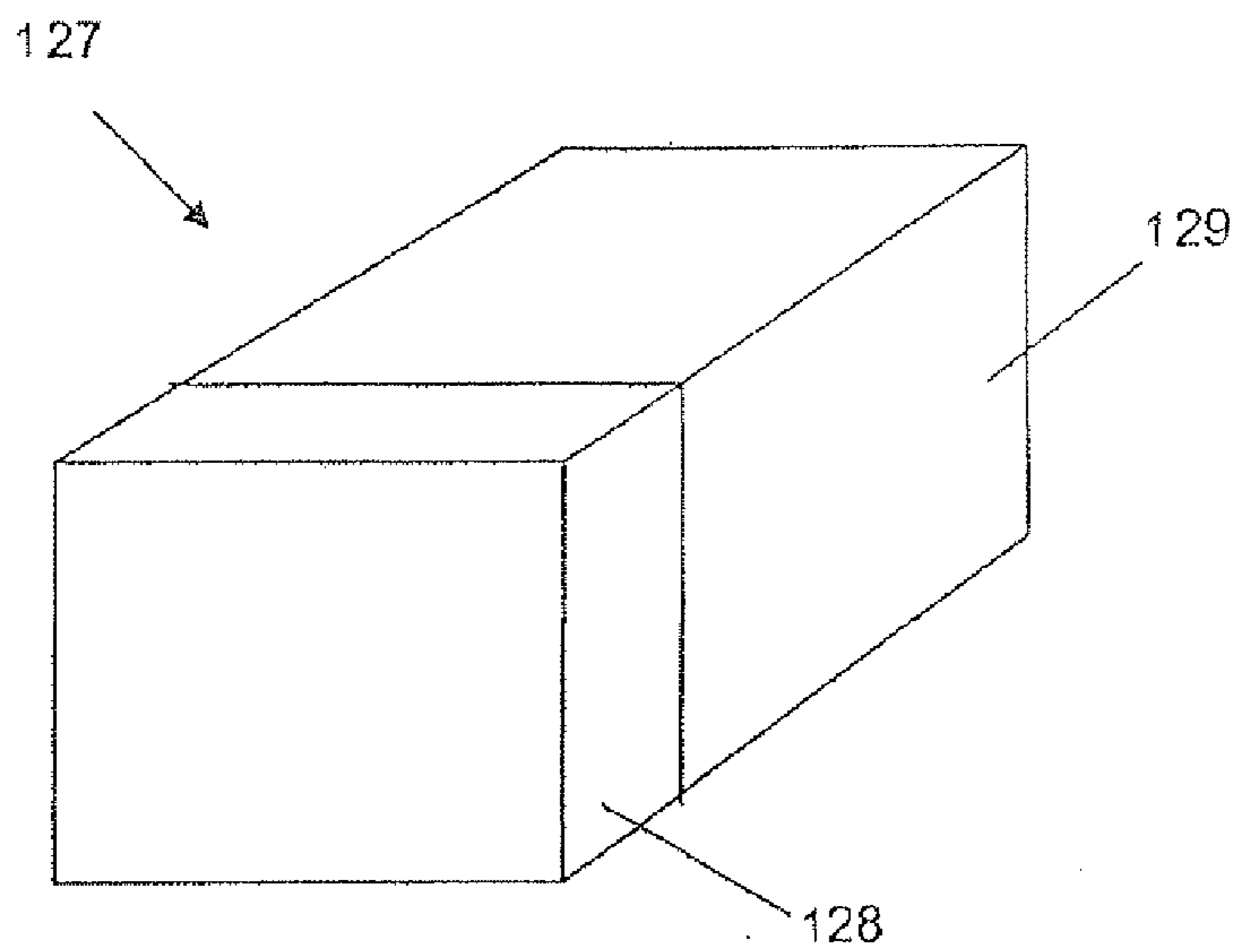


Fig. 11

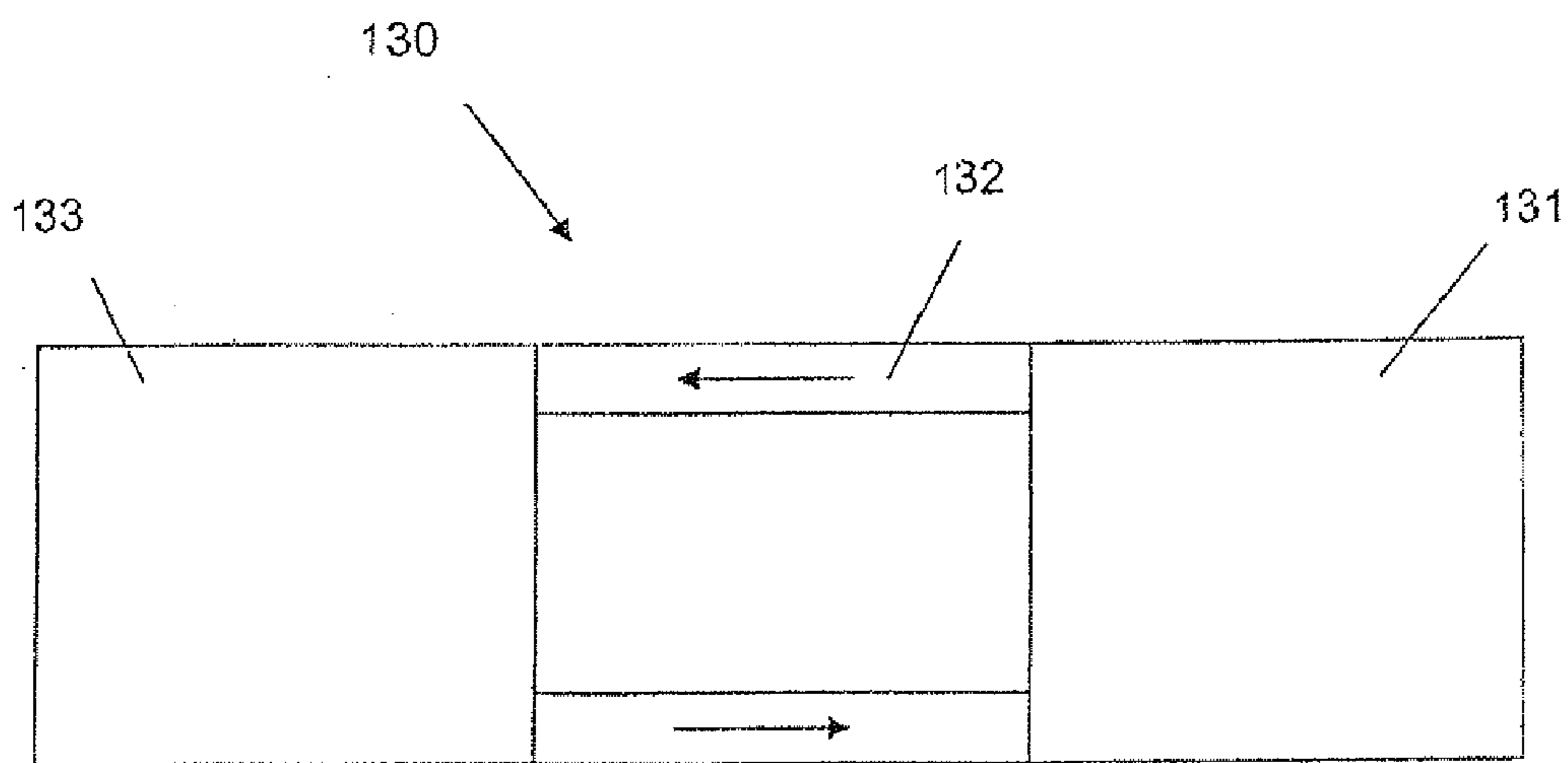
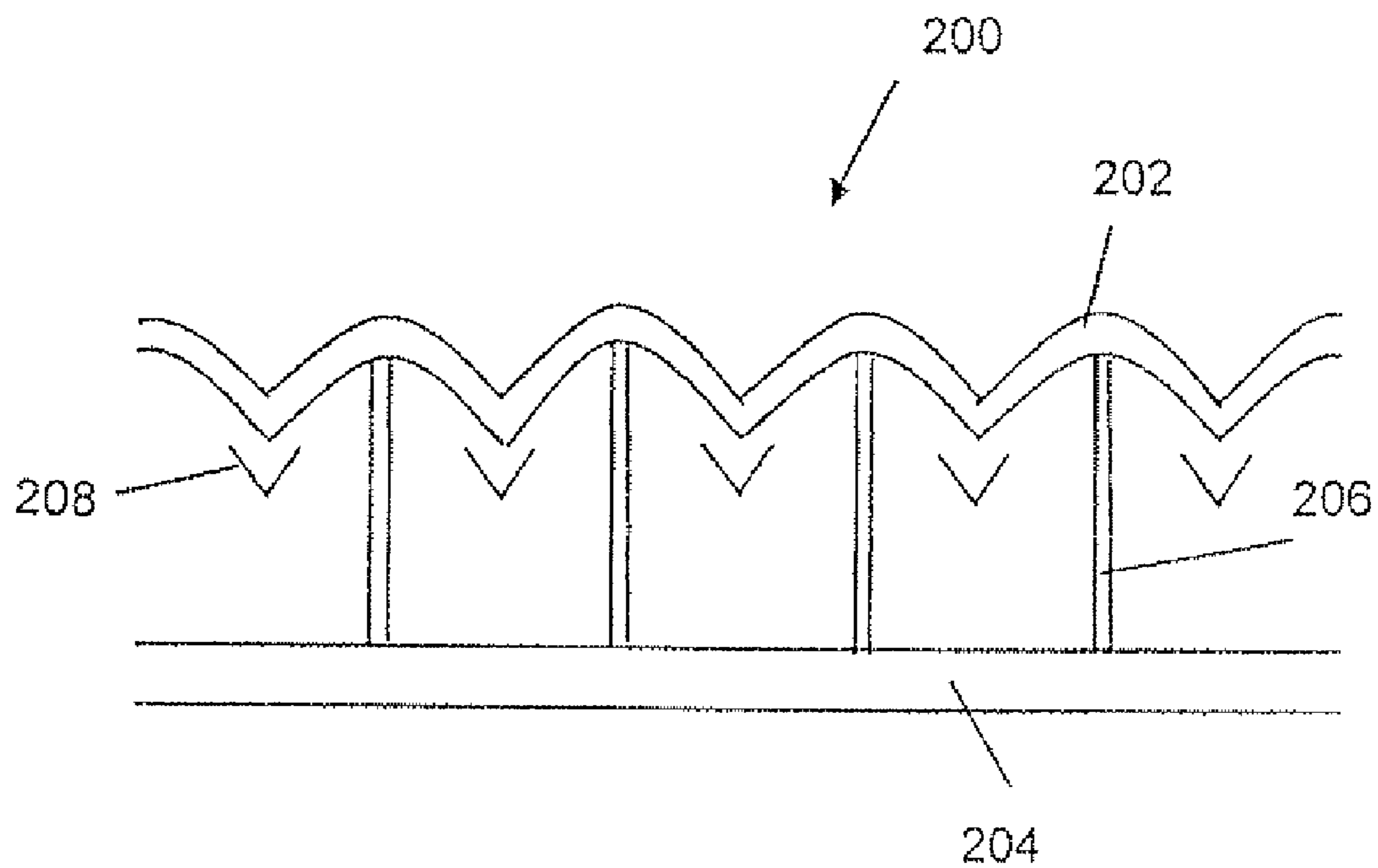
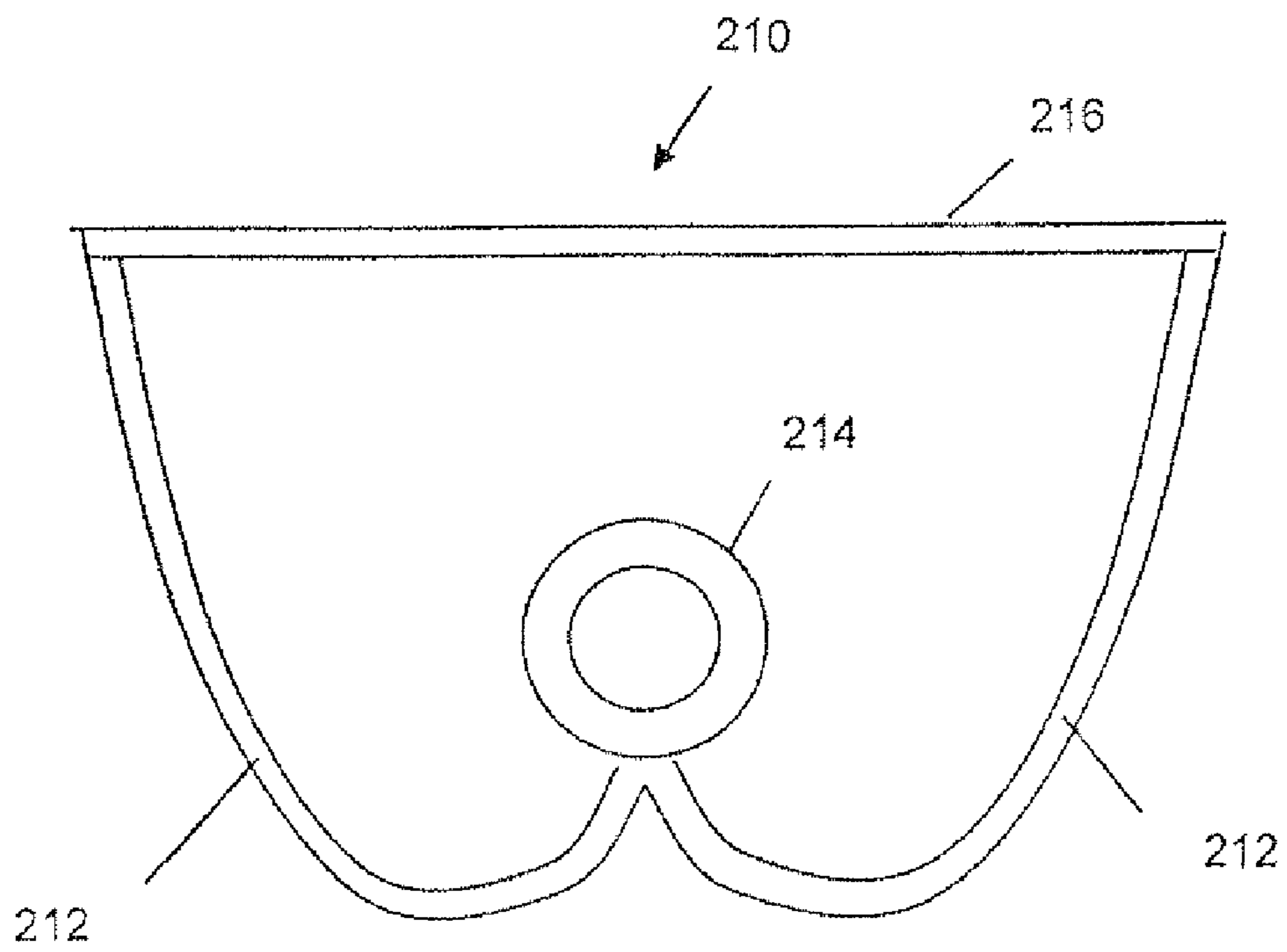


Fig. 12



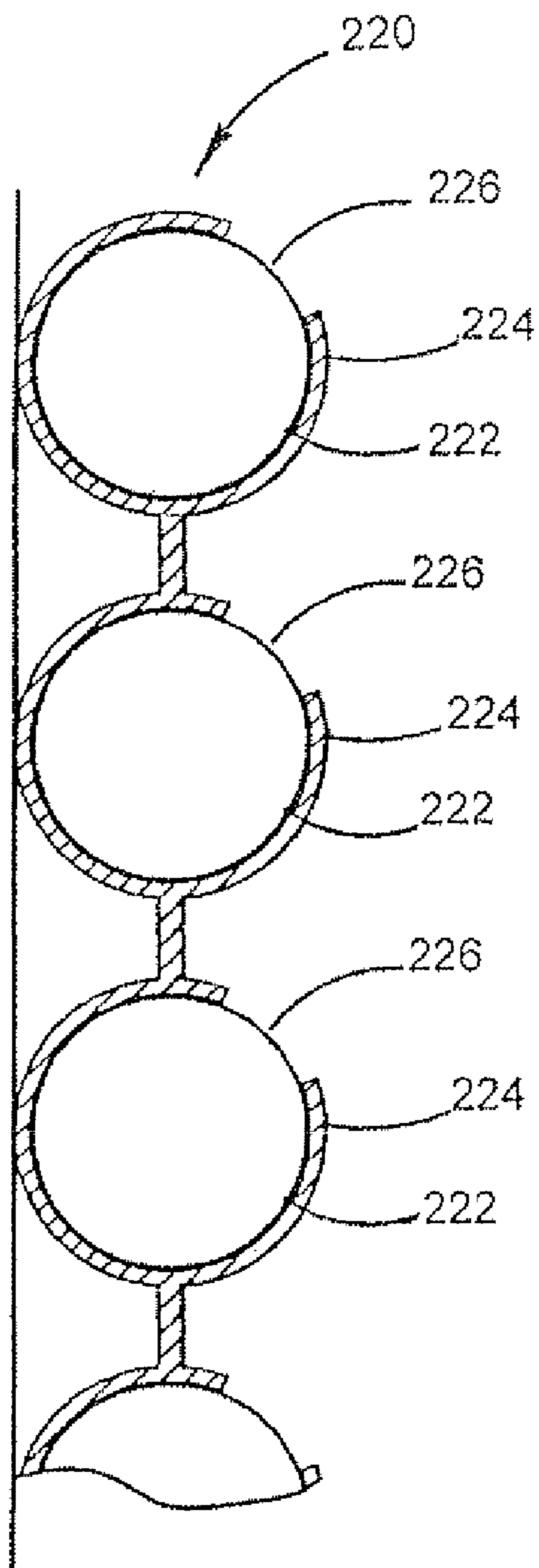


*Fig. 13*



**Fig.14**





**Fig. 15a**

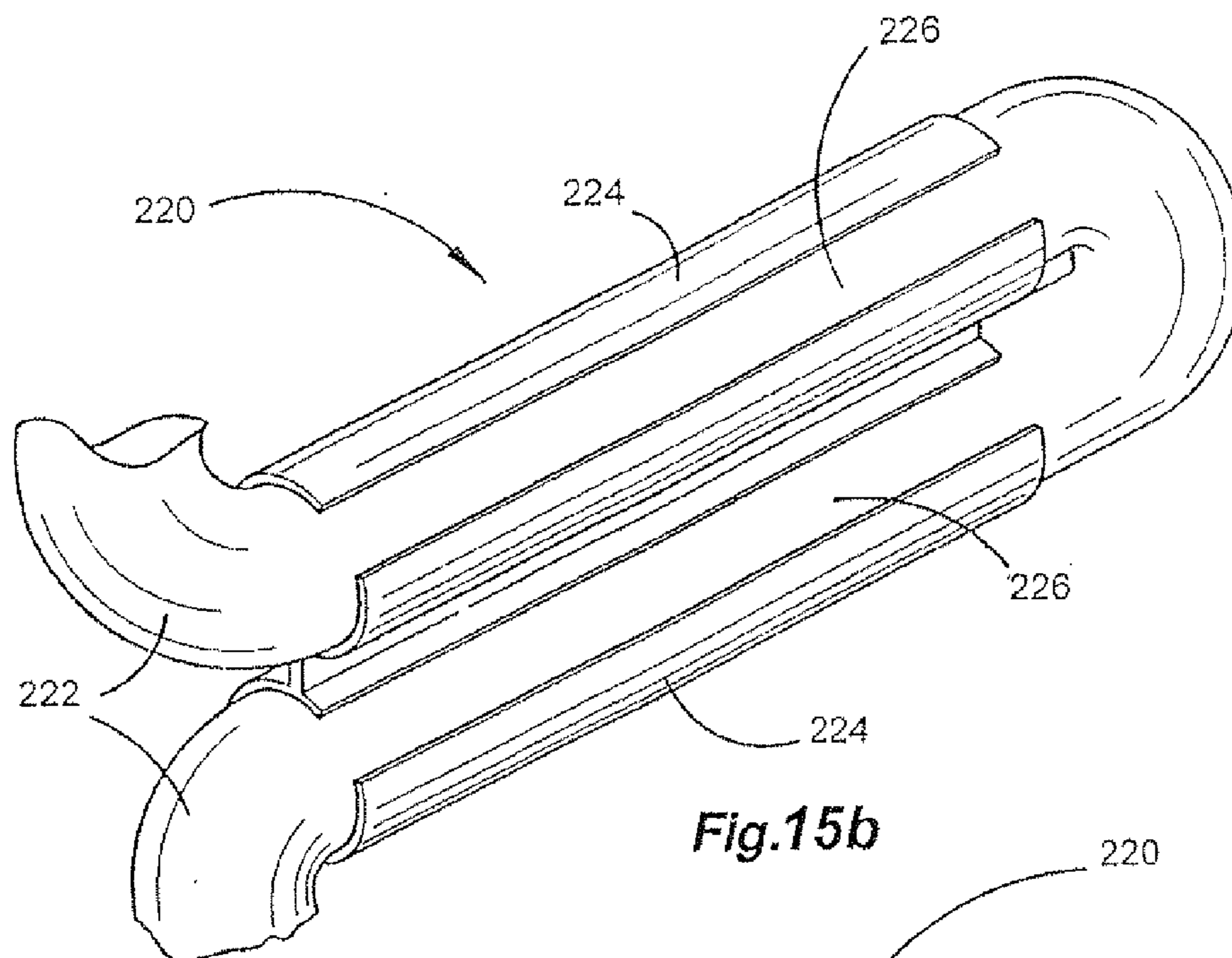


Fig.15b

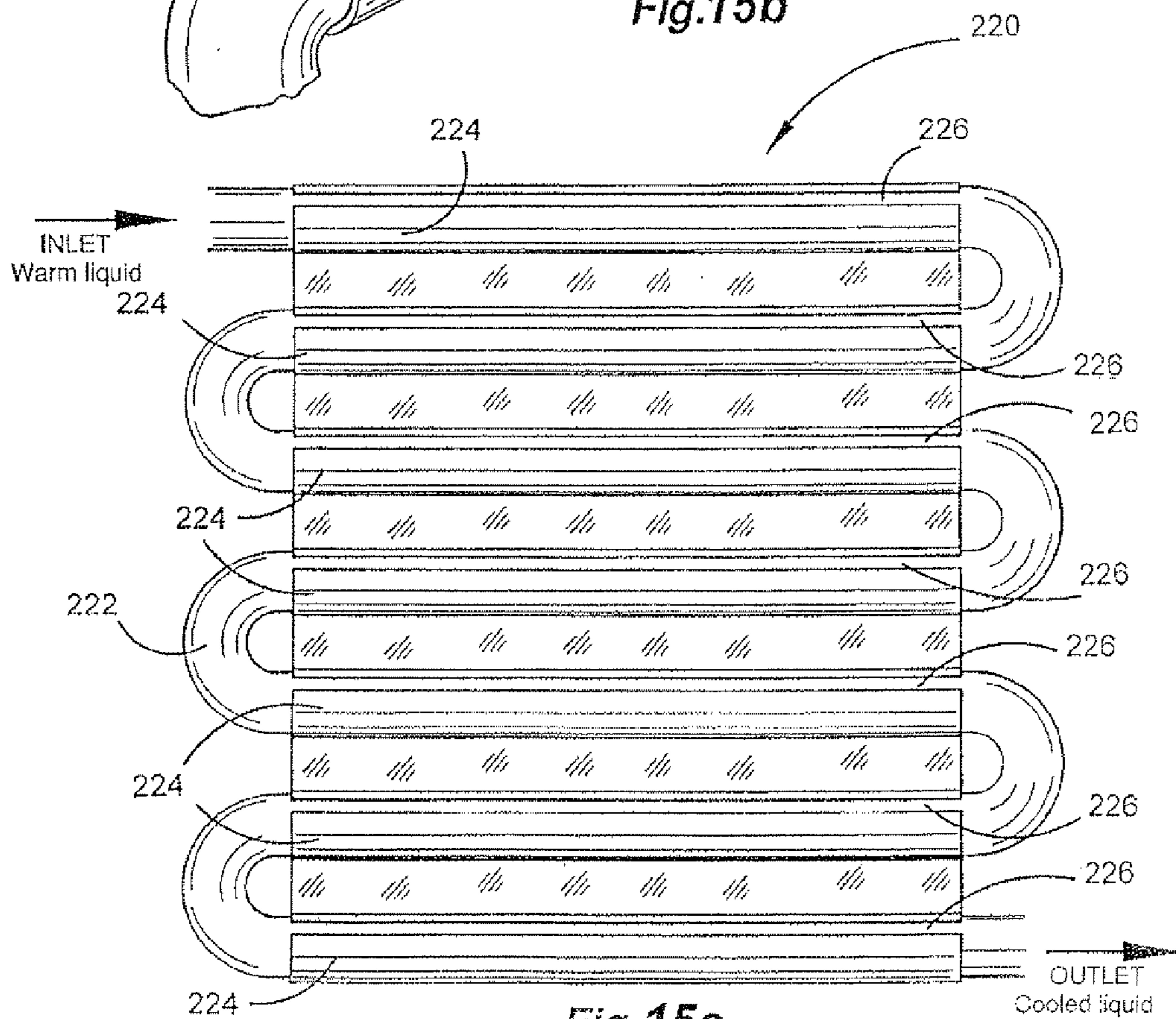
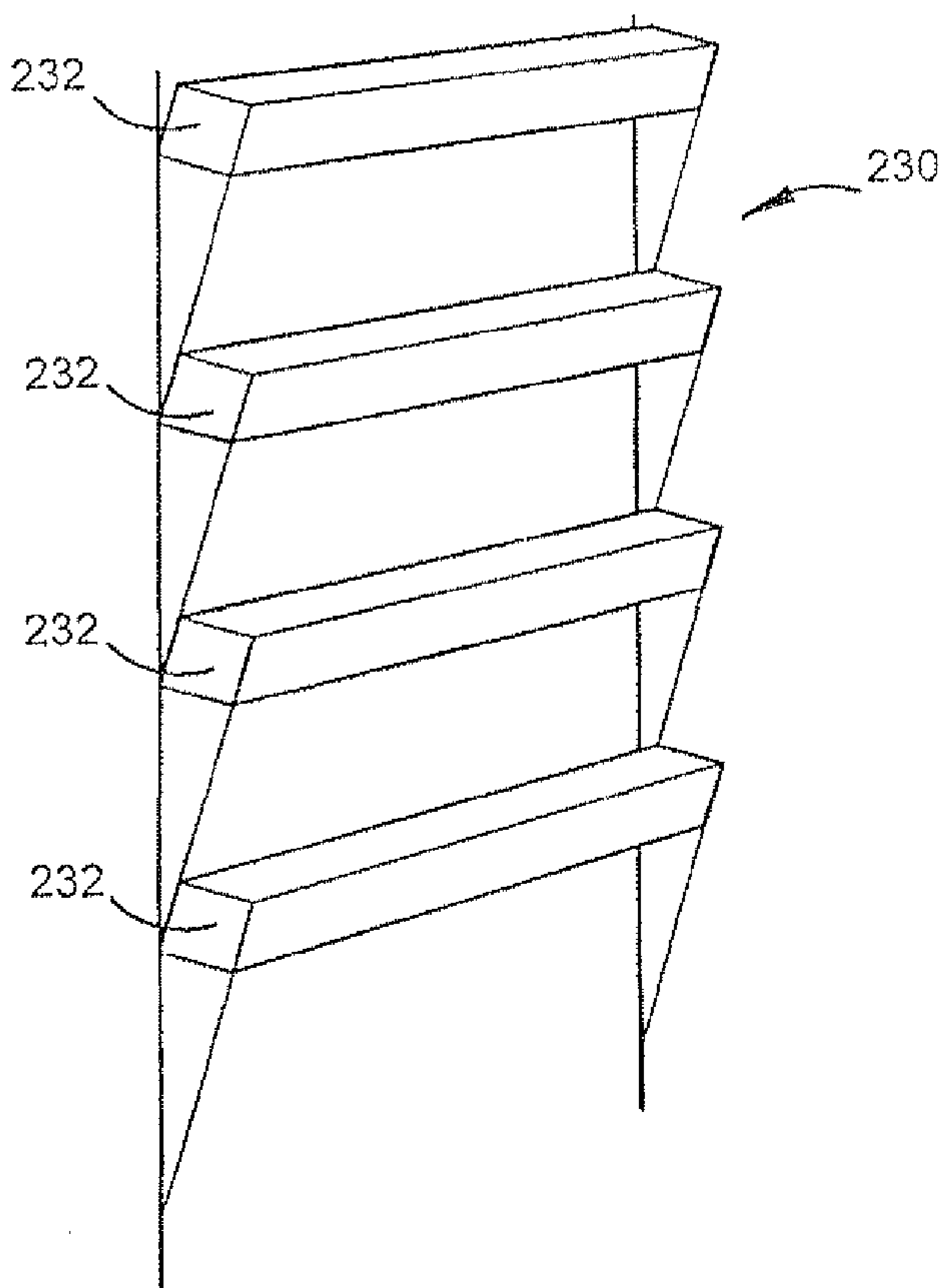
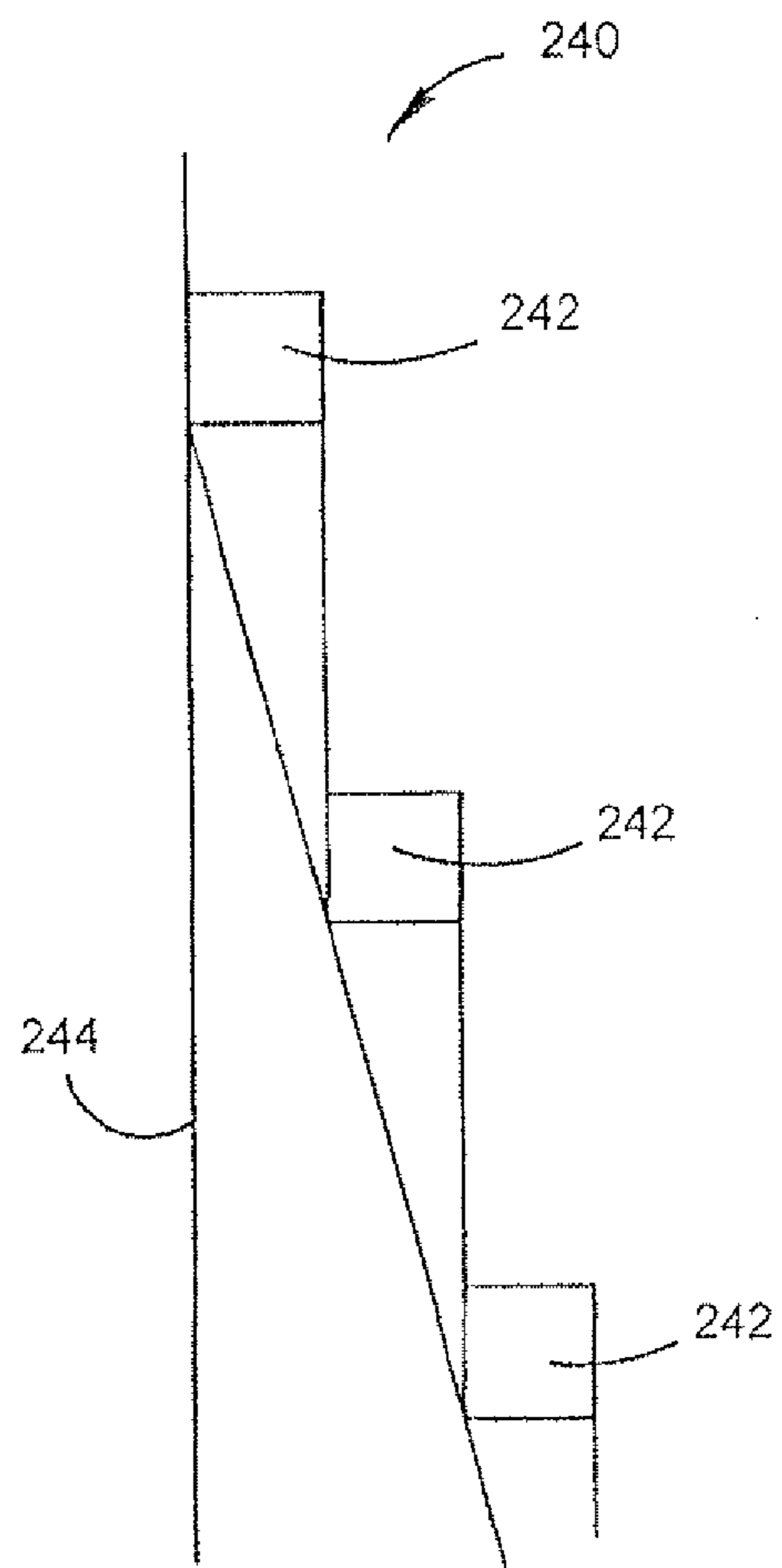


Fig.15c





**Fig.16**



**Fig.17**

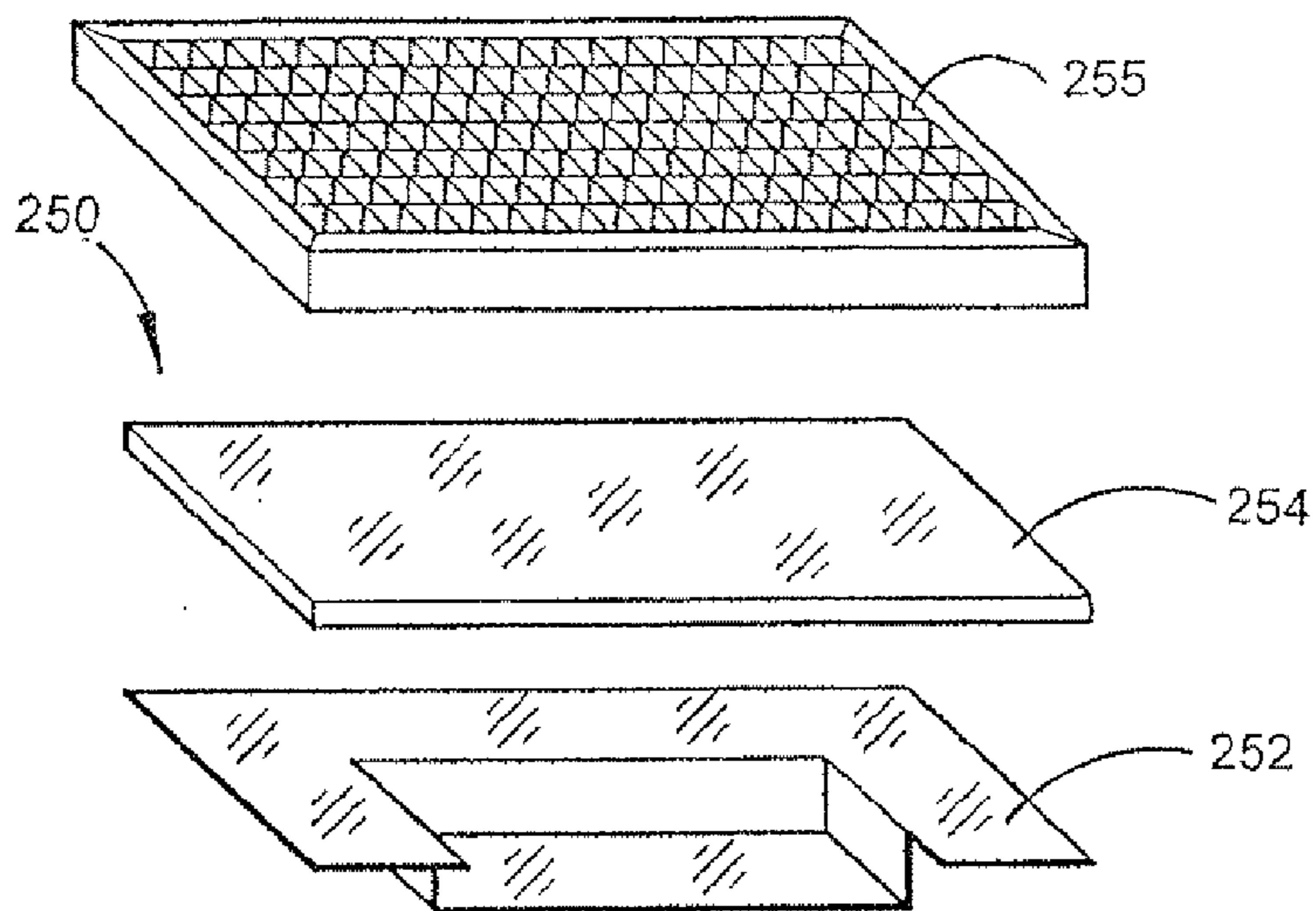


Fig. 18(a)

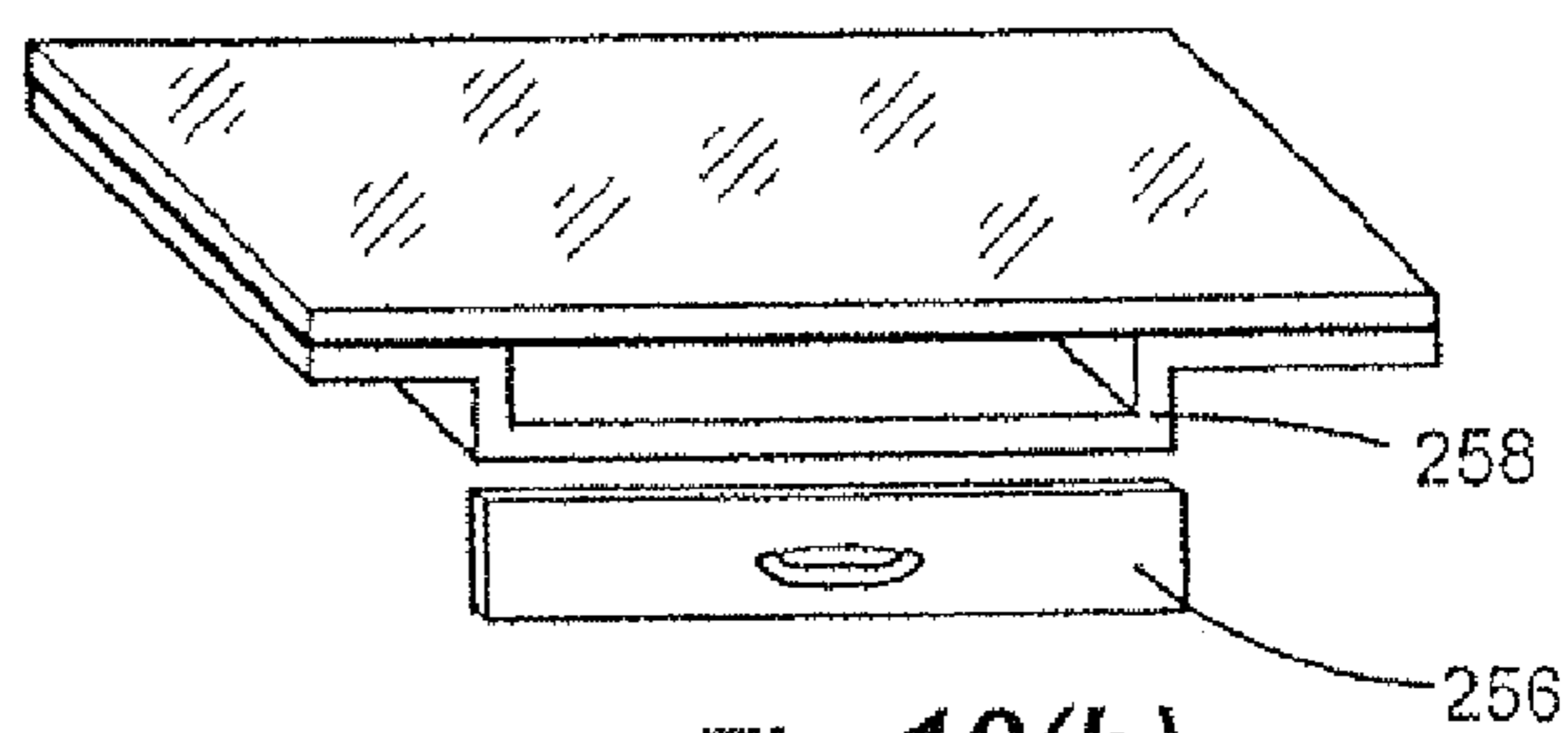


Fig. 18(b)

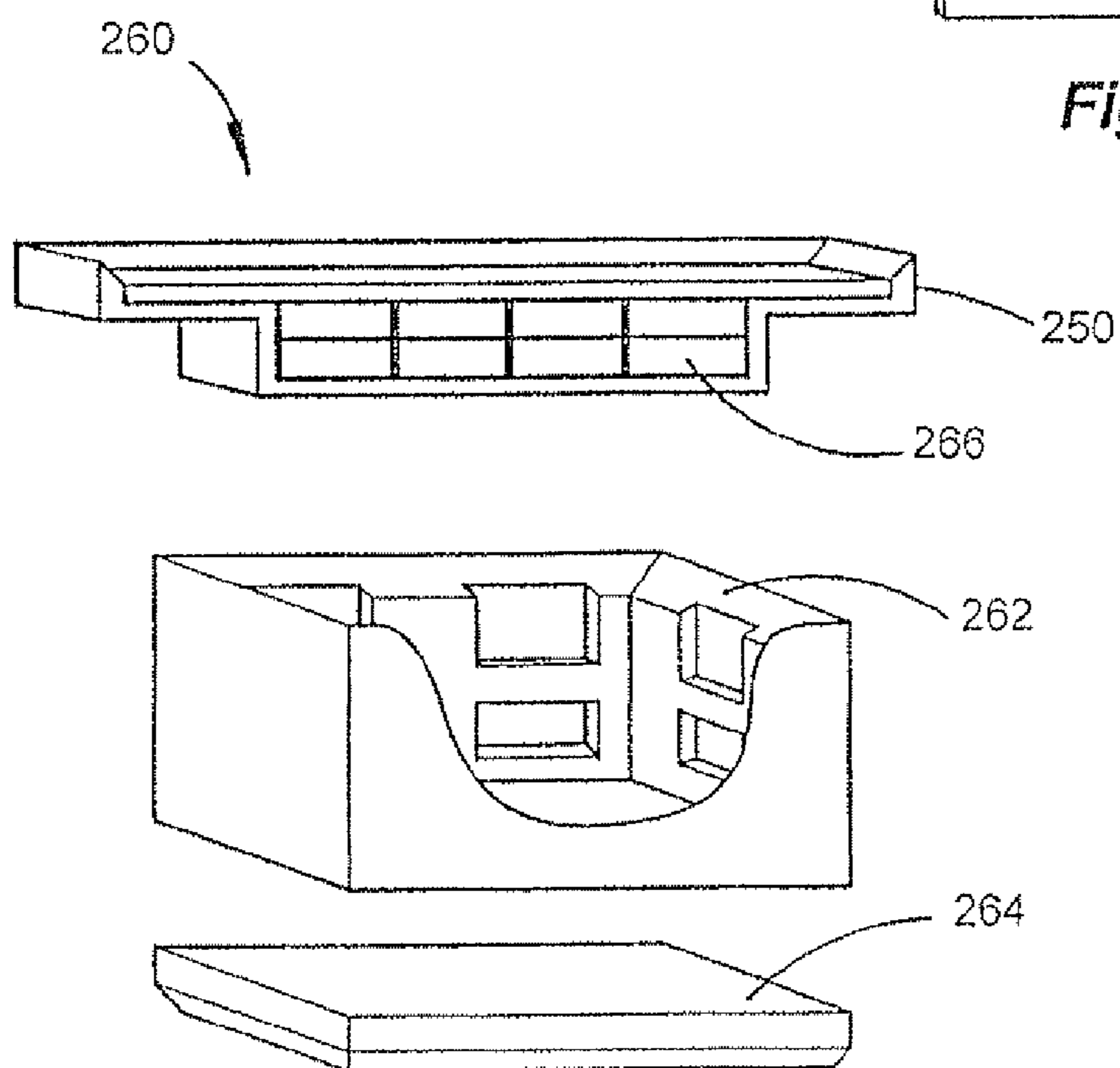
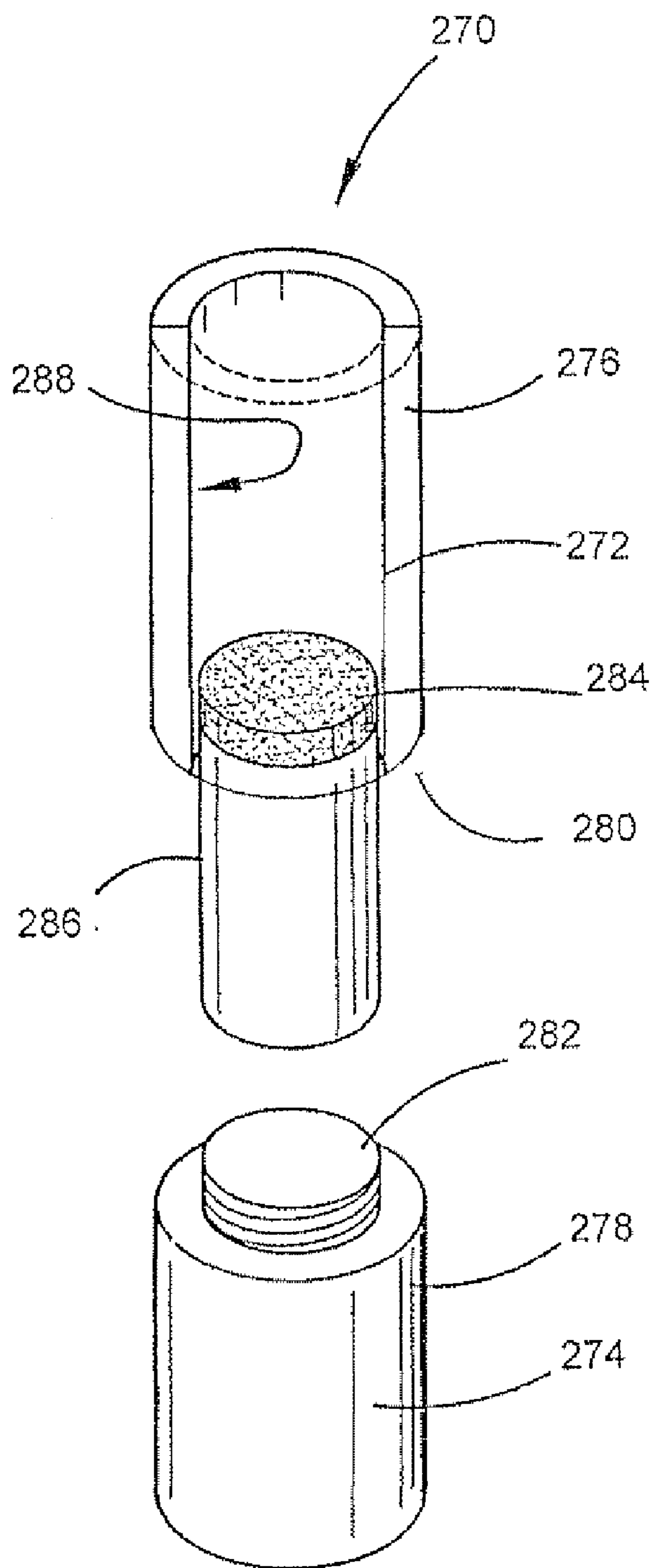


Fig. 19





**Fig. 20**

## ELEMENT FOR EMISSION OF THERMAL RADIATION

### FIELD OF THE INVENTION

**[0001]** The present invention broadly relates to an element for emission of thermal radiation.

### BACKGROUND OF THE INVENTION

**[0002]** Various methods are used to cool interior spaces of buildings, refrigerate food, condense water or reduce the temperature of objects. These methods have in common that they require relatively large amounts of energy, which typically are provided in the form of electrical energy. For example, in countries which have a relatively warm climate the electrical energy required for cooling often exceeds the available electrical energy, which may result in a breakdown of a power grid. Further, electrical energy is at this time still at least partially generated using non-renewable energy resources, for example by burning coal, which is of concern for the environment and contributes to global warming. Consequently, it would be advantageous if cooling could be achieved in a manner that uses less energy. There is a need for technological advancement.

### SUMMARY OF THE INVENTION

**[0003]** The present invention provides an element for emission of thermal radiation, the element comprising particles arranged for receiving thermal energy and emitting at least a portion of the received thermal energy in the form of the thermal radiation, the thermal radiation predominantly having a wavelength or wavelength range within an atmospheric window wavelength range in which the atmosphere of the Earth has a reduced average absorption and emission compared with an average absorption and emission in an adjacent wavelength range whereby absorption by the element of radiation from the atmosphere is reduced.

**[0004]** Because the atmosphere of the Earth has very low absorption within the atmospheric window wavelength range, only a very small amount of radiation is returned from the atmosphere to the particles within that wavelength range and emitted radiation is largely directed through the atmosphere and into Space where the typical temperature is of the order of 4 Kelvin. As a consequence, thermal energy received by the element is “pumped” away by the element.

**[0005]** The atmospheric window wavelength range typically includes a minimum of the average absorption of the atmosphere of the Earth. The atmosphere has atmospheric windows within the wavelength ranges of 3 to 5  $\mu\text{m}$  and 7.9  $\mu\text{m}$  to 13  $\mu\text{m}$ . Within these wavelength ranges the emission of the sun is also negligible and often regarded as zero, which has the added advantage that even during daytime the element only absorbs very little radiation from the sun within that wavelength range.

**[0006]** The element according to embodiments of the present invention and a medium that may be in thermal contact with the element typically is cooled or cooling is facilitated without the need for electrical energy. In particular during the night, or when irradiation by the sun is avoided, cooling well below ambient temperature is possible.

**[0007]** The particles may be distributed throughout the element, which in this case also comprises a material that is substantially transmissive for radiation having a wavelength within the atmospheric window range. Alternatively, the ele-

ment may comprise a surface portion, such as a coating, in which the particles are concentrated and which is arranged so that the thermal radiation can be emitted. The element may also comprise a membrane which locates the particles.

**[0008]** The element may also comprise a cover that may be suspended over a body portion of the element or that may be provided in the form of a cover layer that is in direct contact with the body portion. The cover typically is transmissive for the thermal radiation emitted by the particles and protects the particles from hot breezes and other external influences that could reduce the cooling efficiency. The cover typically comprises a thermally insulating material. For example, the cover may comprise a polymeric material such as polyethylene. Further, the cover may comprise an oxide or sulphide material, which typically is arranged to block at least a portion of incident UV radiation. In one specific example the oxide or sulphide material is positioned on or over the polyethylene material and also protects the polyethylene. This example combines the relative strength of typical polyethylene material with the UV protective function of the sulphide or oxide material, which also increases the lifespan of the polyethylene material. The polymeric material and the oxide or sulphide material typically are arranged so that relatively high transmittance for radiation having a wavelength within the atmospheric window is retained. For example, the oxide or sulphide material may be a layer that is positioned on or over the polymeric material. The sulphide or oxide layer typically has a thickness that is selected so that in use at least the majority of incident UV radiation is blocked and the cover is substantially transmissive for radiation having a wavelength range within the atmospheric window wavelength range. The thickness of the layer typically is within the range of 100 nm-1000 nm, 150 nm-300 nm and typically is of the order of 200 nm.

**[0009]** The element may further comprise wall portions that define an interior space within which a medium that is to be cooled is in use located. The wall portions typically comprise a reflective material. The element may include thermally insulating materials and may for example form an at least partially thermally insulated container.

**[0010]** The element may also comprise a structure that has projecting wall portions which are positioned so that, in use, incoming radiation from regions of the atmosphere, which are near the horizon, is substantially blocked off. It is known that for such radiation the atmospheric window is less transmissive, because the atmosphere is “thicker” for radiation traveling closer to the horizon. Being less transmissive, the atmosphere then also radiates more strongly at these wavelengths from directions close to the horizon. Consequently, avoiding that such radiation can reach the particles improves the cooling efficiency of the element. The projecting wall portions typically are reflective for the thermal radiation emitted by the particles. The structure may also comprise the above-described cover.

**[0011]** The projecting wall portions typically are reflective for the thermal radiation emitted by the particles and may be positioned so that, in use, thermal radiation emitted by the particles or reflected by the projecting wall portions is directed in a direction towards Space and in a direction away from the horizon. The projecting wall portions typically are formed from a material that has low thermal emittance.

**[0012]** In one specific embodiment the element comprises a concentrator such as a “CPC” concentrator or a parabolic dish or trough concentrator. In this case the projecting wall por-



tions typically form a portion of the concentrator. The concentrator typically is arranged so that radiation emitted from substantially all regions of the conduit is directed towards the sky by the concentrator. Further, the projecting wall portion has the added advantage that heating of the particles, and/or of the medium that is to be cooled by the particles, by a hot breeze that may in use pass over the element is reduced.

**[0013]** In another specific embodiment the element forms a part of, or is provided in the form of, an object and is arranged for cooling of the object and/or a medium that is in thermal contact with the object.

**[0014]** The element may be in contact with the portion of the object and may also be adhered to, formed on or otherwise applied to the portion of the object.

**[0015]** In one specific embodiment the object includes a container, such as a can, in which for example food or a liquid may be located.

**[0016]** For example, the object may be a container, such as a food container or a container for transportation or storage of medicine, organs, blood, or anything else that is to be cooled. Further, the object may be an electronic device and the element may be arranged for cooling of the electronic device or may form a part of any means for transportation including automobiles, trucks, train carriages and shipment containers and the like, which require cooling of an interior portion.

**[0017]** The element may also be a part of a structure, such as a building or a house. For example, the element may be provided in the form of a window, roof tile, roof sheet or skylight. For example if the element is provided in a form that is substantially transparent for visible light, the element may comprise a substantially transparent polymeric material that comprises the particles for emission of the thermal radiation. The element may in this embodiment also comprise a honeycomb-like structure that provides additional strength. The element may further comprise a material, such as a further type of particles, that is arranged for absorbing incoming radiation in the near infrared wavelength range. In this case the element may be arranged so that the incoming near infrared radiation is absorbed and the resulting absorbed thermal energy is at least partially re-emitted in the form of thermal radiation by the particles arranged for emission of radiation having a wavelength within the atmospheric window wavelength range.

**[0018]** A person skilled in the art will appreciate that there are many additional examples of objects which may comprise the element or which the element may form.

**[0019]** In embodiments of the present invention the element is arranged to enable cooling to temperatures that are 5°, 10°, 20° below an ambient temperature or even lower.

**[0020]** The element may also be arranged to extract heat at a finite rate at a temperature below ambient. The element may be arranged so that cooling rates such as 40, 60, 80 W per m<sup>2</sup> of cooling material area are possible at temperatures that are 5°, 10° or more below ambient temperature.

**[0021]** The particles may be arranged for generation of ionic surface plasmon resonances having a wavelength or wavelength range within the atmospheric window wavelength range.

**[0022]** Throughout this specification the term “ionic surface plasmon” is used for an excitation that involves movement of ions (and consequently relates to surface phonons), such as that often referred to as “Fröhlich resonance”.

**[0023]** The particles typically are arranged so that at least some, typically the majority or all, of the ionic surface plas-

mons have a wavelength within the wavelength range from 1-7 μm, 2-6 μm, or 3-5 μm, and/or any one of 5-16 μm, 7-14 μm, 8-13 μm and 7.9-13 μm.

**[0024]** However, it is to be appreciated that at least a portion of the particles may also be arranged so that the ionic surface plasmons are generated at a wavelength range that is partially outside the atmospheric window wavelength range. Further, the atmospheric window wavelength range may be one of a plurality of atmospheric window ranges, such as the wavelength range of 3-5 μm and 7.9 to 13 μm.

**[0025]** In one specific embodiment of the present invention the particles comprise, or are entirely composed of, SiC or another suitable material.

**[0026]** At least a portion of the particles may also be arranged for emission of radiation by a physical mechanism other than that associated with the generation of ionic surface plasmons. The particles may be composed of any suitable material that is arranged for emission of radiation having a wavelength within the atmospheric window wavelength range. Alternatively or additionally, the element may comprise a material that is arranged for emission of radiation having a wavelength outside the atmospheric window range.

**[0027]** The element may comprise a polymeric material, such as a coating, that is transmissive for radiation of a predetermined range of wavelength. For example, the particles may be embedded in the polymeric material or may be located adjacent the polymeric material.

**[0028]** The element may also be arranged to reflect at least some incident radiation, such as radiation from the atmosphere and/or from the sun in the daytime. The element may comprise a reflective material that is provided in the form of a layer positioned below the particles and may be arranged to reflect at least a portion of incident radiation. Alternatively or additionally, the element may comprise reflective particles that are dispersed within an at least partially transparent material, such as the above-described polymeric material.

**[0029]** In one embodiment the element comprises at least one channel for a fluid whereby the element is arranged for cooling the fluid.

**[0030]** It is to be appreciated that in variations of the above-described embodiments the element may not necessarily comprise particles that are arranged for emission of thermal radiation having a wavelength within the atmospheric window wavelength range, but the particles may be replaced by at least one layer that is arranged for emission of thermal radiation having a wavelength within the atmospheric window wavelength range. For example, the at least one layer may comprise a granular structure, a porous structure or may have a surface that is profiled so that the at least one layer is arranged for generation of ionic surface plasmon resonances having a wavelength or wavelength range within the atmospheric window wavelength range. Alternatively, the at least one layer may be a part of a multi-layered structure that is arranged for generation of ionic surface plasmon resonances having a wavelength or wavelength range within the atmospheric window wavelength range.

**[0031]** The present invention provides in a second aspect an element for emission of thermal radiation, the element comprising at least one layer that is arranged for receiving thermal energy and emitting at least a portion of the received thermal energy in the form of the thermal radiation, the thermal radiation predominantly having a wavelength or wavelength range within an atmospheric window wavelength range in which the atmosphere of the Earth has a reduced average absorption



and emission compared with an average absorption and emission in an adjacent wavelength range whereby absorption by the element of radiation from the atmosphere is reduced.

**[0032]** The atmospheric window wavelength range typically is a wavelength range from 3 to 5  $\mu\text{m}$  and/or from 7.9  $\mu\text{m}$  to 13  $\mu\text{m}$ .

**[0033]** The at least one layer typically is arranged for generation of ionic surface plasmon resonances having a wavelength or wavelength range within the atmospheric window wavelength range.

**[0034]** The at least one layer may have a structural property that is selected so that the at least one layer is arranged for generation of ionic surface plasmon resonances having a wavelength or wavelength range within the atmospheric window wavelength range. For example, the at least one layer may comprise grains, or may at least in part be of a porous structure and the structural property may be associated with a grain size or a thickness of residual solid between pores, respectively. Further, the at least one layer may have a surface roughness and the structural property may be associated with thickness or width of surface features of the at least one layer. The grain size, the thickness of residual solid between pores and the thickness or width of surface features of the at least one layer typically are within the range of 50 nm-150 nm.

**[0035]** Alternatively, the at least one layer may be a part of a multi-layered structure having layer thicknesses that are selected so that the multi-layered structure is arranged for generation of ionic surface plasmon resonances having a wavelength or wavelength range within the atmospheric window wavelength range.

**[0036]** The present invention provides in a third aspect a cooling system comprising the above-described element in accordance with the first or second aspect of the present invention, the element forming a part of an object and the cooling system comprising a thermally insulating wall portion for reducing exchange of thermal energy between a portion of the object an environment of the cooling system.

**[0037]** The element may be in contact with the portion of the object and may also be adhered to, formed on or otherwise applied to the portion of the object.

**[0038]** The object may include a container, such as a can, in which for example food or a liquid may be located.

**[0039]** The thermally insulating wall portion typically is arranged so that the element of the object is in use enabled to emit thermal radiation in a direction away from the cooling system. The cooling system typically is also arranged so that the object is positionable in, and removable from, an interior formed by the thermally insulating wall portion.

**[0040]** The cooling system may further comprise a removable lid-portion and a base portion that together with the thermally insulating wall portion form an enclosure in which in use the object is positioned, the lid-portion being formed from a material that is transmissive for thermal radiation emitted by the particles of the element.

**[0041]** The present invention provides in a fourth aspect a cooling device for cooling a medium, the cooling device comprising an element for emission of thermal radiation, the element comprising particles arranged for receiving thermal energy and emitting at least a portion of the received thermal energy in the form of the thermal radiation, the thermal radiation predominantly having a wavelength or wavelength range within an atmospheric window wavelength range in which the atmosphere of the Earth has a reduced average absorption and emission compared with an average absorption and emis-

sion in an adjacent wavelength range whereby absorption by the element of radiation from the atmosphere is reduced.

**[0042]** For example, the cooling device may comprise the element for emission of thermal radiation in accordance with the first aspect of the present invention.

**[0043]** The atmospheric window wavelength range typically includes a minimum of the average absorption of the atmosphere of the Earth. The atmosphere has atmospheric windows within the wavelength ranges of 3 to 5  $\mu\text{m}$  and 7.9  $\mu\text{m}$  to 13  $\mu\text{m}$ . Within these wavelength ranges the emission of the sun is also negligible and often regarded as zero, which has the added advantage that even during daytime the element of the cooling device only absorbs very little radiation from the sun within that wavelength range.

**[0044]** The cooling device may be arranged so that the medium is in direct or indirect thermal contact with the element.

**[0045]** The medium typically is in use cooled or cooling is facilitated without the need for electrical energy. In particular during the night, or when irradiation by the sun is avoided, cooling well below ambient temperature is possible.

**[0046]** For example, the cooling device may be an air-conditioning device or a refrigerator or the like. The element of the cooling device may be in thermal contact, either directly or indirectly, with a fluid, such as a liquid or gaseous medium, and may be arranged for cooling of the fluid or facilitating cooling of the fluid.

**[0047]** The cooling device may also be arranged to facilitate operation of another device. For example, the cooling device may be arranged to correspond with the other cooling device and may be mountable on, or in the proximity of the other device so that a "hybrid" device is formed. In one specific embodiment the cooling device is arranged to facilitate operation of an air-conditioning device or refrigerator. For example, the cooling device may be arranged to cool a fluid, especially during the night, which is then used to facilitate heat exchange of the other cooling device, such as the refrigerator or the air-conditioning device. In one variation the cooling device is arranged to store the cooled fluid for a period of time, for example during the night.

**[0048]** In one specific embodiment the cooling device is arranged so that in use the element receives thermal energy from a fluid. In this embodiment the cooling device comprises a conduit that is arranged for directing the fluid to and from the proximity of the element of the cooling device so that in use the cooling device results in cooling of the fluid. The cooling device is arranged so that the element receives thermal energy directly or indirectly from the fluid. In this embodiment the conduit may provided in the form of a tubular portion and at least a portion of the conduit may be arranged for mounting at an exterior surface of a building or structure. Further, the cooling device may be arranged so that in use at least a portion of an interior of the building or structure is cooled by the cooling device and the cooling device may be arranged so that the fluid is directed in a closed cycle along the proximity of the element and along a portion from which the fluid in use absorbs thermal energy from the interior of the building or structure. In one example the conduit comprises a region at which in use the element is enabled to emit the thermal radiation in a direction away from the cooling device. The conduit may further comprise a thermally insulated region that is arranged to reduce exchange of thermal energy between the fluid and an environment of the conduit. The cooling device may further be arranged so that



the region at which in use the element is enabled to emit the thermal radiation is oriented so that the thermal radiation is emitted in a direction directly towards Space.

[0049] In another example the cooling device is provided in the form of an evaporative cooling device and the cooling device may be arranged for cooling of a liquid prior to evaporation of the liquid or may otherwise facilitate cooling of the evaporative cooling device. The cooling device may also be provided in the form of a radiator or heat exchanger and the element may enable or facilitate the cooling.

[0050] The particles may be distributed throughout the element of the cooling device, which may also comprise a material that is substantially transmissive for radiation having a wavelength within the atmospheric window range. Alternatively, the element of the cooling device may comprise a surface portion, such as a coating, in which the particles are concentrated and which is arranged so that the thermal radiation can be emitted. The element of the cooling device may also comprise a membrane which locates the particles.

[0051] The cooling device may also comprise a cover that may be suspended over a body portion of the element or that may be provided in the form of a cover layer that is in direct contact with the body portion. The cover typically is transmissive for the thermal radiation and protects the particles from hot breezes and other external influences that could reduce the cooling efficiency. The cover typically is arranged for reduction of exchange of thermal energy by convection. For example, the cover may comprise a polymeric material such as polyethylene. Further, the cover may comprise an oxide or sulphide material, which typically is arranged to block at least a portion of incident UV radiation.

[0052] In one specific example the oxide or sulphide material is positioned on or over the polyethylene material and also protects the polyethylene. This example combines the relative strength of typical polyethylene material with the UV protective function of the sulphide or oxide material, which also increases the lifespan of the polyethylene material. The polymeric material and the oxide or sulphide material typically are arranged so that relatively high transmittance for radiation having a wavelength within the atmospheric window is retained. For example, the oxide or sulphide material may be a layer that is positioned on or over the polymeric material. The sulphide or oxide layer typically has a thickness that is selected so that in use at least the majority of incident UV radiation is blocked and the cover is substantially transmissive for radiation having a wavelength range within the atmospheric window wavelength range. The thickness of the layer typically is within the range of 1000 nm-100 nm, 300 nm-150 nm and typically is of the order of 200 nm.

[0053] The cooling device may further comprise wall portions that define an interior space within which a medium that is to be cooled is in use located. The cooling device may include thermally insulating materials and may for example form an at least partially thermally insulated container.

[0054] Further, the cooling device may comprise a closure that is removable so that the medium is locatable within the interior space and the interior space is closable. The cooling device may also be arranged to cool the medium that after removal from the cooling device, is used to cool another medium. For example, the medium may comprise a phase change material.

[0055] The cooling device may also comprise a conduit for guidance of emitted radiation from the particles to a remote location. For example, the conduit may be provided in the

form of a hollow tube with reflective interior wall portions that are arranged to reflect the emitted thermal radiation and thereby guide the thermal radiation to an end-portion of the conduit that may be open or covered with a suitable material that is substantially transmissive for the thermal radiation.

[0056] The cooling device may also form a part of, or may be provided in the form of, a water condenser. The water condenser may be arranged so that water is generated by condensation of water vapour in air, for example in an environment that has insufficient supply of fresh water, including, but not limited to, remote areas and areas on or near an ocean. The water condenser may form a part of a water desalination device in which the cooling by the element facilitates condensation of water.

[0057] In one specific embodiment the cooling device forms a part of a water purifier. In this case the cooling device may comprise a first layer that includes the particles for emission of thermal radiation and a second layer that is spaced apart from the first layer. The second layer comprises in this embodiment a material that is arranged for absorbing a portion of incoming solar radiation and thereby increasing the temperature of the second layer. The cooling device typically is arranged so that the first layer is in use positioned over the second layer. A fluid, such as water containing impurities, may be directed through the space formed between the first and the second layer. The water will be heated in the proximity of the second layer and, as the first layer is cooled by the particles for emission of the thermal radiation, developed water vapour will condense at the first layer. The water formed by condensation of water vapour at the first layer typically is substantially free of the impurities, such as salt in the case of sea water.

[0058] The cooling device may also comprise a structure that has projecting wall portions which are positioned so that, in use, incoming radiation from regions of the atmosphere, which are near the horizon, is substantially blocked off. It is known that for such radiation the atmospheric window is less transmissive, because the atmosphere is "thicker" for radiation traveling closer to the horizon. Being less transmissive, the atmosphere then also radiates more strongly at these wavelengths from directions close to the horizon. Consequently, avoiding that such radiation can reach the particles improves the cooling efficiency of the cooling device. The structure may also comprise the above-described cover.

[0059] The projecting wall portions typically are reflective for the thermal radiation emitted by the particles and may be positioned so that, in use, thermal radiation emitted by the particles or reflected off the projecting wall portions is directed in a direction towards Space and in a direction away from the horizon. The projecting wall portions typically are formed from a material that has low thermal emittance.

[0060] In one specific embodiment the cooling device comprises a concentrator such as a "CPC" concentrator or a parabolic dish or trough concentrator. In this case the projecting wall portions typically form a portion of the concentrator. For example, the cooling device may comprise a conduit for fluid that is positioned at or near a focal region of the concentrator. The conduit may comprise the particles that emit in use the thermal radiation. A fluid may be directed through the conduit so that in use the fluid is cooled. The concentrator typically is arranged so that radiation emitted from substantially all regions of the conduit is directed towards the sky by the concentrator. Further, the projecting wall portion has the added advantage that heating of the particles, and/or of the



medium that is to be cooled by the particles, by a hot breeze that may in use pass over the is reduced.

**[0061]** The cooling device may be arranged so that cooling is facilitated by the element. Alternatively, the cooling device may be arranged so that cooling is effected solely by the element.

**[0062]** In another specific embodiment the cooling device forms a part of an object and is arranged for cooling of the object and/or a medium that is in thermal contact with the object.

**[0063]** For example, the object may be a container, such as a food container or a container for transportation or storage of medicine, organs, blood, or anything else that is to be cooled. Further, the object may be an electronic device and the cooling device may be arranged for cooling of the electronic device or may form a part of any means for transportation including automobiles, trucks, train carriages and shipment containers and the like, which require cooling of an interior portion.

**[0064]** The following will describe a selection of further possible features and the function of the cooling device in more detail.

**[0065]** In embodiments of the present invention the cooling device is arranged to enable cooling to temperatures that are 5°, 10°, 20° below an ambient temperature or even lower.

**[0066]** The cooling device may also be arranged to extract heat at a finite rate at a temperature below ambient. The cooling device may be arranged so that cooling rates such as 40, 60, 80 W/m<sup>2</sup> of cooling material area are possible at temperatures that are 5°, 10° or more below ambient temperature.

**[0067]** The particles may be arranged for generation of ionic surface plasmon resonances having a wavelength or wavelength range within the atmospheric window wavelength range.

**[0068]** The particles typically are arranged so that at least some, typically the majority or all, of the ionic surface plasmons have a wavelength within the wavelength range from 1-7 μm, 2-6 μm, or 3-5 μm, and/or any one of 5-16 μm, 7-14 μm, 8-13 μm and 7.9-13 μm.

**[0069]** It is to be appreciated, however, that at least a portion of the particles may also be arranged so that the ionic surface plasmons are generated at a wavelength range that is partially outside the atmospheric window wavelength range. Further, the atmospheric window wavelength range may be one of a plurality of atmospheric window ranges, such as the wavelength range of 3-5 μm and 7.9 to 13 μm.

**[0070]** In one specific embodiment of the present invention the particles comprise, or may be entirely composed of, SiC or another suitable material.

**[0071]** At least a portion of the particles may also be arranged for emission of radiation by a physical mechanism other than that associated with the generation of ionic surface plasmons. The particles may be composed of any suitable material that is arranged for emission of radiation having a wavelength within the atmospheric window wavelength range. Alternatively or additionally, the cooling device may comprise a material that is arranged for emission of radiation having a wavelength outside the atmospheric window range.

**[0072]** The element of the cooling device may comprise a polymeric material, such as a coating, that is transmissive for radiation of a predetermined range of wavelength. For example, the particles may be embedded in the polymeric material or may be located adjacent the polymeric material.

**[0073]** The cooling device may also be arranged to reflect at least some incident radiation, such as radiation from the atmosphere and/or from the sun in the daytime. The cooling device may comprise a reflective material that is provided in the form of a layer positioned below the particles and may be arranged to reflect at least a portion of incident radiation. Alternatively or additionally, the element may comprise reflective particles that are dispersed within an at least partially transparent material, such as the above-described polymeric material.

**[0074]** In one embodiment the cooling device comprises at least one channel for a fluid whereby the cooling device is arranged for cooling the fluid.

**[0075]** It is to be appreciated that in variations of the above-described embodiments the element may not necessarily comprise particles that are arranged for emission of thermal radiation having a wavelength within the atmospheric window wavelength range, but the particles may be replaced by at least one layer that is arranged for emission of thermal radiation having a wavelength within the atmospheric window wavelength range. For example, the at least one layer may comprise a granular structure, a porous structure or have a surface that is profiled so that the at least one layer is arranged for generation of ionic surface plasmon resonances having a wavelength or wavelength range within the atmospheric window wavelength range. Alternatively, the at least one layer may be a part of a multi-layered structure that is arranged for generation of ionic surface plasmon resonances having a wavelength or wavelength range within the atmospheric window wavelength range.

**[0076]** The present invention provides in a fifth aspect a cooling device for cooling a medium, the cooling device comprising an element for emission of thermal radiation, the element comprising at least one layer arranged for receiving thermal energy and emitting at least a portion of the received thermal energy in the form of the thermal radiation, the thermal radiation predominantly having a wavelength or wavelength range within an atmospheric window wavelength range in which the atmosphere of the Earth has a reduced average absorption and emission compared with an average absorption and emission in an adjacent wavelength range whereby absorption by the element of radiation from the atmosphere is reduced.

**[0077]** The atmospheric window wavelength range typically is a wavelength range from 3 to 5 μm and/or from 7.9 μm to 13 μm.

**[0078]** The at least one layer typically is arranged for generation of ionic surface plasmon resonances having a wavelength or wavelength range within the atmospheric window wavelength range.

**[0079]** In one example the at least one layer has a structural property that is selected so that the at least one layer is arranged for generation of ionic surface plasmon resonances having a wavelength or wavelength range within the atmospheric window wavelength range. For example, the at least one layer may comprise grains, or may at least in part be of a porous structure and the structural property may be associated with a grain size or a thickness of residual solid between pores, respectively. Further, the at least one layer may have a surface roughness and the structural property may be associated with thickness or width of surface features of the at least one layer. The grain size, the thickness of residual solid



between pores and the thickness or width of surface features of the at least one layer typically within the range of 50 nm-150 nm.

[0080] Alternatively, the at least one layer may be a part of a multi-layered structure having layer thicknesses that are selected so that the multi-layered structure is arranged for generation of ionic surface plasmon resonances having a wavelength or wavelength range within the atmospheric window wavelength range.

[0081] The present invention provides in a sixth aspect a cooling system comprising the above-described cooling device, the cooling device comprising wall portions that define an interior space within which a medium that is to be cooled is in use located, the cooling system further comprising a cooling container that is arranged to receive the medium cooled by the cooling device so that the cooled medium is enabled to cool an interior portion of the cooling container.

[0082] The cooling device typically includes thermally insulating materials.

[0083] Further, the cooling container may comprise a closure that is removable so that the cooled medium is locatable within the interior of the cooling container and the cooling container is closable.

[0084] The present invention provides in a seventh aspect a method of cooling a medium comprising the steps of:

[0085] receiving thermal energy by a medium;

[0086] directing the thermal energy to a remote location;

[0087] receiving the thermal energy by an element positioned at the remote location; and

[0088] emitting at least a portion of the thermal energy received by the element in the form of the thermal radiation predominantly having a wavelength or wavelength range within an atmospheric window wavelength range in which the atmosphere of the Earth has a reduced average absorption and emission compared with an average absorption and emission in an adjacent wavelength range.

[0089] The method typically comprises moving the medium so that the thermal energy received by the medium transported to the element.

[0090] The invention will be more fully understood from the following description of specific embodiments of the invention. The description is provided with reference to the accompanying drawings.

#### BRIEF DESCRIPTION OF THE DRAWINGS

[0091] FIG. 1 shows an a device incorporating an element for emission of thermal radiation according to an embodiment of the present invention;

[0092] FIGS. 2, 3 (a), 3(b) and 4 show objects incorporating an element for emission of thermal radiation according to an embodiment of the present invention;

[0093] FIG. 5 shows a transmission spectrum of the atmosphere of the Earth as a function of wavelength;

[0094] FIGS. 6-8 show elements for emission of thermal radiation according to embodiments of the present invention;

[0095] FIG. 9 shows a cooling system according to a specific embodiment of the present invention;

[0096] FIG. 10 shows an a cooling device according to an embodiment of the present invention;

[0097] FIGS. 11 and 12 show cooling devices according to embodiments of the present invention;

[0098] FIGS. 13-18 show further examples of cooling devices according to embodiments of the present invention;

[0099] FIG. 19 shows a cooling system according to a embodiment of the present invention; and

[0100] FIG. 20 shows a cooling device according to a further embodiment of the present invention.

#### DETAILED DESCRIPTION OF SPECIFIC EMBODIMENTS

[0101] Generally, the element comprises particles that are arranged for emission of radiation having a wavelength within a range referred to as the "atmospheric window wavelength range". The atmospheric window wavelength range is a wavelength range within which the absorption and emission of radiation by the atmosphere of the Earth is strongly reduced or zero. Radiation emitted from the element within that wavelength range is largely transmitted through the atmosphere to Space where the average temperature is 4 Kelvin. Further, as within that wavelength range typically very little or no radiation is received by the element, the element functions as a pump of thermal energy.

[0102] The element comprises a cooling material that is disclosed in Australian provisional patent application No 2007903673 and U.S. patent application Ser. No. 11/765,217. These patent applications are hereby incorporated by cross-reference. Further details of the function of the element will be discussed with reference to FIGS. 4-7.

[0103] Referring initially to FIGS. 1-3, examples of elements and objects incorporating the element according to specific embodiments of the present invention are now described.

[0104] FIG. 1 shows a cooling element 10 in accordance with an embodiment of the present invention. For example, the element 10 may be arranged for cooling a medium that is in thermal contact with a portion of the element 10. The element 10 is arranged so that thermal radiation can be emitted from surface portion 12 to the atmosphere either directly or indirectly. The element 10 is arranged so that a portion of the thermal energy received from the medium is emitted by the element 10 in the form of thermal radiation so that cooling of the medium is facilitated by the element 10.

[0105] The cooling element 10 may form a part of an evaporative cooling device. In this case the element 10 typically is arranged to cool a liquid, typically water, prior to evaporation. Alternatively, the element 10 may form a part of any other type of air-conditioning device and the element 10 may be arranged for facilitating cooling of a fluid that in use circulates through portions of the air-conditioning unit.

[0106] Further, the element 10 may form a part of be a radiator, heat exchanger, or refrigerator or any other type of cooling device. A person skilled in the art will appreciate that there are numerous examples of cooling devices in which the element 10 may be incorporated.

[0107] FIG. 2 shows an example of a structure 14 in which an element for emission of the thermal radiation according to embodiments of the present invention is incorporated. The structure 14 is in this embodiment a house or building or the like and includes roof-covering and/or other external coverings that are provided in the form of objects 16. For example, each object 16 may be a roof tile or a roof-sheet which comprises a metallic, ceramic or polymeric material. The object 16 comprises a surface portion that incorporates the particles for emission of the thermal radiation and is positioned over the metallic, ceramic or polymeric material. For example, the particles may be embedded in a coating material that is applied by painting or otherwise to the metallic,



ceramic or polymeric material of the object **16**. The coating material is substantially transmissive for radiation having a wavelength within the atmospheric window wavelength range. Alternatively, the particles may be positioned on a surface portion of the object **16** without being embedded in a coating material.

[0108] The object **16** is arranged so that thermal radiation is emitted which results in cooling of a roof space of the house or building **14**. This particular application has significant advantages in particular for warmer regions of the Earth. During hot summer days roof spaces gain a substantial amount of thermal energy and often maintain a substantial portion of that thermal energy during the night. The element **16** facilitates cooling of the roof space and thereby improves comfort of living in the house or building **14**. In one specific embodiment of the present invention large portions of the external surface, such as the roof area of a house or building **14**, are covered by the object **16**.

[0109] Referring again to FIG. 2, the structure **14** may also include further objects that incorporate an element for emission of the thermal radiation and that are provided in the form of windows, such as window **18**. The window **18** is arranged so that a portion of near-infrared radiation is blocked.

[0110] Referring now to FIG. 3 (a), a further example of an object that incorporates the element **10** for emission of thermal radiation is now described. The object **20** is in this example a container for containing food, medical articles, blood or organs and the like or any other objects or matter that requires cooling. An external surface portion of the object **20** comprises the particles arranged for emission of thermal radiation. Emission of the thermal radiation results in cooling of the container **20** and an interior portion thereof.

[0111] FIG. 3 (b) shows an example of a further variation of a container that includes the element **12**. In this case the container **22** has wall portions **24** that are composed of a thermally insulating material. The container **22** also comprises a top portion **26** that is composed of a material that is substantially transmissive for the thermal radiation having a wavelength range within the atmospheric window wavelength range. The top portion may also have thermally insulating properties and may for example comprise iron oxide or ZnS. A medium that is to be cooled is positioned adjacent the element **12**. This embodiment has the added advantage that the thermally insulating wall portions further increase the cooling efficiency. Further, the element **10** and the medium that is to be cooled are protected from any hot breezes that may also reduce the cooling efficiency.

[0112] A person skilled in the art will appreciate that there are numerous examples of objects in which the element for emission of thermal radiation maybe incorporated. For example, the element may form a portion of an electronic device, such as an integrated electronic device, and may be arranged for cooling of the electronic device.

[0113] FIG. 4 shows a structure **28** that is largely transmissive for visible radiation and may be used as a roof-sheet, window or sky light and the like. The structure **28** comprises a first layer **30** and a second layer **32**. The first layer **30** and the second layer **32** are connected by members **34** so that a honey-comb like structure is formed that is relatively stabile. The structure **28** comprises a polymeric material and has particles incorporated within that material so that the structure **28** has advantages analogous to those of the above-discussed element.

[0114] A person skilled in the art will also appreciate that the cooling element has numerous applications for cooling objects, or fluids. If an object or fluid is to be cooled, the cooling element may be arranged to cool the object or fluid directly. Alternatively, the cooling element may be arranged for cooling the object or fluid indirectly by cooling another fluid of material, which then cools the fluid or object that is to be cooled.

[0115] Referring now to FIGS. 5 and 6, the function of the element for emission of thermal radiation according to a specific embodiment of the present invention are now described in further detail. FIG. 5 shows a transmission spectrum **34** of the atmosphere of the Earth for substantially cloud free conditions. The average transmission is increased to nearly 1 within the range of approximately 7.9 to 13  $\mu\text{m}$  compared to adjacent wavelength ranges. Further, the average transmission of the atmosphere is increased within a wavelength range of 3-5  $\mu\text{m}$ . Within these wavelength ranges the atmosphere of the Earth has "windows". Plot **36** is an estimation of the emission spectrum of a black body having a temperature of 100° C., which was calculated using Wein's law and gives an example of the emission spectrum for a medium that may be cooled using the cooling material according to embodiments of the present invention.

[0116] FIG. 6 shows a secondary electron microscopy micrograph of a surface portion of the element according to a specific embodiment of the present invention.

[0117] The element **40** comprises a reflective metallic layer **42**, which in this embodiment is provided in the form of an aluminum layer positioned on a substrate. Further, the element **40** comprises SiC particles **44**, which are positioned on the metallic layer **42**. The SiC particles **44** have an average diameter of approximately 50 nm and are deposited using suitable spin coating procedures.

[0118] The SiC particles **44** are in this embodiment nanoparticles and the majority of the surface of the particles **44** is exposed to air. The particles **44** show resonantly enhanced absorption and emission of radiation at a wavelength range of 10 to 13  $\mu\text{m}$ . Within that wavelength range ionic surface plasmons are generated. The wavelength range of resonant ionic surface plasmon emission is within the above-described atmospheric window wavelength range. For that wavelength range the average absorption of the atmosphere of the Earth is very low and consequently very little radiation in this wavelength range is transferred from the atmosphere to the element **40**.

[0119] The energy associated with the emitted radiation is largely drawn from the thermal energy of the particles **44** and/or from a medium that is in thermal contact with the particles **44**. Due to the atmospheric window, the emitted radiation is largely transmitted through the atmosphere and directed to Space where the temperature typically is 4 Kelvin. Consequently, the element **40** functions as a pump of thermal energy even if the cooling material, or a medium that is in thermal contact with the cooling material, has a temperature below ambient temperature.

[0120] The reflective material **42** has the added advantage that a large portion of incident radiation is reflected away from the element **40** and consequently thermal absorption of radiation having a wavelength within or outside the atmospheric window is reduced, which increases cooling efficiency.

[0121] In variations of the above-described embodiment the particles **44** may be composed of other suitable materials



that show ionic surface plasmon resonances, such as BN and BeO. Further, the particles **44** may also be composed of materials that are not arranged for ionic plasmon generation at a wavelength within the atmospheric window wavelength range, but may be arranged for emission of radiation within that wavelength range by any other possible mechanism. For example, SiO, silicon oxynitride particles exhibit relatively strong emissions within that wavelength range.

[0122] The reflective material **42** improves the cooling efficiency. However, it is to be appreciated that the element may not necessarily comprise a reflective material. Further, the particles **44** may be embedded in a transparent material, such as a suitable polymeric material that is positioned upon the reflective material **42**. For example, the polymeric material may comprise polyethylene or a fluorinated material.

[0123] Referring now to FIG. 7, an element according to a second specific embodiment of the present invention is now described.

[0124] In this embodiment the element **50** also comprises the above-described particles **44**. In this example, however, the particles **44** are positioned within a matrix of a polymeric material **54** that is largely transparent to thermal radiation within a black body wavelength range, such as radiation having a wavelength within the range of 3-28  $\mu\text{m}$ , or a wavelength range outside one or both of 3-5 and 7.9-13  $\mu\text{m}$ , or most of solar spectral range in addition to the black body radiation range. For example, the polymeric material **54** may comprise polyethylene or a fluorinated polymeric material.

[0125] In contrast to the element **40**, incident radiation is not reflected, but largely transmitted through the cooling material **50**, which also reduces thermal absorption of radiation directed to the element **50** and thereby improves the cooling efficiency.

[0126] In addition, the element **50** comprises particles **56**. In general, the particles **56** have a spectrally selective property that complements a spectrally selective property of the particles **44**. In this example, the particles **56** are arranged for generation of electronic surface plasmons in the near infrared (NIR) wavelength range. Within that wavelength range the particles **56** absorb radiation, such as radiation originating from the sun. This inhibits transmission of a portion of incident radiation, which facilitates the cooling. In this embodiment the cooling material **50** is arranged so that the thermal energy, that is present as a consequence of the absorbed solar radiation, is emitted by the particles **44**.

[0127] For example, the element **50** may be provided in the form of a skylight or a window, such as window element **18**. In this case the cooling material **50** typically is arranged so that a large portion of the visible light originating from the sun can penetrate through the element **50**. The particles **44** emit radiation within the atmospheric window wavelength range, which results in cooling, and the particles **56** partially "block" thermal radiation originating from the sun which facilitates the cooling.

[0128] For example, the particles **56** may comprise indium tin oxide, tin oxide, LaB<sub>6</sub>, SbSn oxide, or aluminium doped ZnO.

[0129] It is to be appreciated, however, that in variations of the above-described embodiment the particles **56** may also be arranged for generation of electronic surface plasmons at any other suitable wavelength range.

[0130] In addition, the element **50** may comprise a layered structure of dielectric and/or metallic materials having layer thicknesses that are selected to effect reflection of thermal

radiation, such as thermal radiation originating from the atmosphere, which further facilitates cooling.

[0131] Further, the element **30** may also comprise a layer structured material that is arranged so that a portion of light within the visible wavelength range is reflected and light that is transmitted through the element **50** is of a particular colour, which has advantageous applications for aesthetic purposes.

[0132] With reference to FIG. 8 an element **60** according to another specific embodiment of the present invention is now described. The element **60** corresponds to the element **50** shown in FIG. 7 and described above, but is in this embodiment positioned on a reflective layer **62**. The element **60** is particularly suited for cooling a medium that may be in thermal contact with the cooling material **60**. In this embodiment the reflective layer **62** is a metallic layer that is arranged to reflect radiation having a wide wavelength range and originating, for example, from the sun.

[0133] For example, the reflective layer **62** may be arranged to reflect the majority of thermal radiation and visible radiation originating from the sun and from the atmosphere, which facilitates cooling of the cooling material **60**. The reflective material may comprise for example Al, Cu, Ag, Au, Ni, Cr, Mo, W or steel including stainless steel.

[0134] In a variation of the embodiment shown in FIG. 8, the reflective material may not be provided in form of a layer, but may be provided in form of reflective particles that are incorporated in the material **54**.

[0135] The elements **50** and **60** may be incorporated into the cooling device **10** or objects **16** and **20**. The element **60** has particularly advantageous applications as window or skylight, such as window **18**.

[0136] Referring now to FIG. 9, a cooling system in accordance with an embodiment of the present invention is now described. FIG. 9 shows the cooling system **90** which comprises an object **92**. For example, the object may be a container, such as a food container, or a can, such as a beverage can. The object **92** includes a top portion **94** to which the above described element for emission of thermal radiation is applied. For example, the element may be provided in the form of a coating functioning in the same manner as the elements **40**, **50** and **60** described with reference to FIGS. 6 to 8.

[0137] In this embodiment, the cooling system **90** comprises a thermally insulating housing **96** in which the object **92** is positioned. Further, the cooling system **90** comprises a lid-portion **98** which is composed of material that is transmissive for thermal radiation emitted by the particles of the element **94**. Further, the cooling system **90** comprises a base portion on which the housing portion **96** and the object **92** are positioned. In this embodiment, the housing portion **96** is taller than the object **92** so that in use the likelihood of incidence of direct sunlight on the object **92** is reduced. Further, the housing portion **96** is sufficiently tall so that in use incoming radiation from the atmosphere, which is incident at angles which are closer to the horizon than to the zenith, is substantially blocked off. The housing portion **96** is reflective for the thermal radiation emitted by the particles and is in use positioned so that thermal radiation emitted by the particles is directed in a direction towards Space and in a direction away from the horizon. Interior wall portions of the housing portion **96** comprise a material that has low thermal emittance.

[0138] The lid-portion **98** creates a barrier for transfer of heat by convection and, at the same time, is transmissive for thermal energy emitted by the particles of the element **94**.



[0139] In use, the particles of element 94 absorb thermal energy from an adjacent portion of the object 92 and emit the absorbed thermal energy in the form of thermal radiation having a wavelength range within the atmospheric wavelength range. The housing portion 96 and the base portion 100 provide thermal insulation and consequently facilitate cooling of the object 92. The cooling system 90 is arranged so that the object is removable from an interior of the housing portion 96.

[0140] It is to be appreciated, however, that the cooling system 90 may be provided in various different forms. For example, the object 92 may not necessarily be a container for food or liquid, but may alternatively be any other type of object. Further, the element 94 may be applied to any side portion of the object and may also be in indirect thermal contact to the object. In addition, the housing portion 96 may have any suitable shape.

[0141] Further, it will be appreciated by those skilled in the art that the particles of the element, such as element 50 or 60 shown in FIGS. 7 and 8, may also be positioned in a membrane that has openings which are suitably sized to locate one or more of the particles. In addition, the element may also comprise projecting wall portions, which may or may not be reflective and which are arranged so that in use it is avoided that radiation that penetrated to atmospheres at regions near the horizon.

[0142] Further, it is to be appreciated that in variations of the above-described embodiments the element may not necessarily comprise particles that are arranged for emission of thermal radiation having a wavelength within the atmospheric window wavelength range, but the particles may be replaced by at least one layer, such as a multi-layered structure, that is arranged for emission of thermal radiation having a wavelength within the atmospheric window wavelength range. The layers of the multi-layered structure typically have thicknesses that are selected so that in use ionic surface plasmon resonances are generated and the ionic surface plasmon resonances have a wavelength or wavelength range within the atmospheric window wavelength range. For example, the multi-layered structure may comprise SiO and SiC layers having a thickness of the order of 50-150 nm.

[0143] Alternatively, the particles may be replaced by grains of a layer having a granular structure, such as a suitable SiC layer. In this case the average diameter of the grains is selected so that the layer is arranged for emission of thermal radiation having a wavelength within the atmospheric window wavelength range. The particles may also be replaced by a porous layer or a layer having a rough surface, such as a suitable SiC layer. In this case an average pore spacing or surface profile, respectively, is selected so that the layer is arranged for emission of thermal radiation having a wavelength within the atmospheric window wavelength range.

[0144] In addition, it is to be appreciated that the element may comprise the above-described particles in addition to the above-described at least one layer. The at least one layer and the particles may both be arranged for emission of thermal radiation having a wavelength range within the atmospheric window wavelength range.

[0145] Referring now to FIGS. 10-12, examples of cooling devices according to specific embodiments of the present invention are now described. Generally, the cooling device may comprise the above-described element for emission of thermal radiation.

[0146] FIG. 10 shows a cooling device 110 that incorporates the element 112. For example, the cooling device may be an air-conditioning device, a radiator, or any other type of cooling device. The cooling device 110 may be arranged for cooling a medium that is in thermal contact with a portion of the cooling device 110. The element 112 is arranged so that thermal radiation can be emitted from surface portion 114 to the atmosphere either directly or indirectly. The cooling device 110 is arranged so that a portion of the thermal energy received from the medium is emitted by the element 112 in the form of thermal radiation so that cooling of the medium is facilitated by the element 112.

[0147] The cooling device 110 may for example be provided in the form of an evaporative cooling device. In this case the element 112 typically is arranged to cool a liquid, typically water, prior to evaporation. Alternatively, the cooling device 110 may be any other type of air-conditioning device and the element 112 may be arranged for facilitating cooling of a fluid that in use circulates through portions of the air-conditioning unit.

[0148] Further, the cooling device 110 may be a radiator, heat exchanger, or refrigerator or any other type of cooling device. A person skilled in the art will appreciate that there are numerous examples of cooling devices in which the element 112 may be incorporated.

[0149] For example, the cooling device 112 may be provided in the form of a container for containing food, medical articles, blood or organs and the like or any other objects or matter that requires cooling. A person skilled in the art will appreciate that there are numerous further examples of cooling devices in which the cooling device may be incorporated. For example, the cooling device may form a portion of an electronic device, such as an integrated electronic device, and may be arranged for cooling of the electronic device.

[0150] Referring now to FIG. 11, another specific example of a cooling device is now described. In this embodiment the cooling device 127 comprises a body portion 128 which includes particles for emission of the thermal radiation. Further, the cooling device 127 comprises a conduit 129. The conduit 129 is a hollow tubular portion with reflective internal wall portions that are arranged to reflect the radiation and thereby guide the radiation to a distal end-portion of the conduit. The conduit 129 is used to channel thermal radiation emitted by the particles of the body portion 128 to the distal end-portion of the conduit 129 that is exposed to the atmosphere.

[0151] For example, the body portion 128 may comprise a thermally absorptive material that is also arranged to reflect the thermal radiation having a wavelength within the atmospheric window wavelength range. This would ensure that radiation generated by the particles of the cooling device 127 is largely directed into the conduit 129.

[0152] It is to be appreciated that the conduit may be provided in any suitable form and may also comprise bent portions.

[0153] FIG. 12 shows another example of the cooling device. Cooling device 130 comprises in this case body portion 31, which is arranged to cool a fluid that is channeled through the body portion 131. The body portion 131 comprises the particles for emission of thermal radiation. The cooled fluid is directed by thermally insulated tubes 132 to and from body portion 133, where heat is absorbed. Consequently, the cooling device 130 functions as heat pump and moves thermal energy from an area within which the body



portion **133** is positioned, such as an interior of a building, to the body portion **131**, which may be positioned outside the building.

[0154] A person skilled in the art will appreciate that the cooling device **130** has numerous applications. For example, the body portion **131** may be positioned at the exterior of a shipping container and the body portion **133** may be positioned so that an interior portion of the shipping container is cooled. In this case the cooling device **130** may also be arranged for cooling a relatively small area of the interior of the container, such as the interior of a refrigeration box, within which relatively low temperatures can be achieved.

[0155] FIG. **13** shows a variation of the cooling device that forms a water purifier. FIG. **13** shows a structure **200** that comprises a first layer **202** and a second layer **102**. The first layer **204** and the second layer **204** are coupled by members **206**. The layer **202** is in this example corrugated and comprises the particles **44**. The particles **56** are separated from the particles **44** and are distributed in the second layer **204**. A fluid is in use directed along the second layer **204** and in channels that are formed by the members **206**. The particles **56** increase the temperature of the second layer **204** by absorbing near-infrared radiation and the particles **44** of the first layer **202** cool the second layer **202**, which results in formation of water vapour and condensation of the water vapour at the first layer **202**. The condensed water is substantially free of impurities, such as salt, that the water may contain. Because of the corrugation of the first layer **202**, the condensed water is collected in channels **208** and available for use.

[0156] It is to be appreciated that the first and second layer of the element **200** may alternatively be mechanically coupled by any other suitable arrangement.

[0157] Referring now to FIG. **14**, a cooling device according to a further embodiment of the present invention is now described. Cooling device **210** comprises reflectors **212**, which in this embodiment are shaped so that a "CPC" concentrator is formed. The cooling device **210** comprises a tube **214** through which in use a fluid is conducted. The tube **214** is coated with a material comprising the particles **44** for emission of thermal radiation having a wavelength within the atmospheric window wavelength range and which in use cool the fluid. The emitted thermal radiation is directed by the reflector portions **212** through cover **216**, which is transmissive for the radiation and may be comprise iron oxide or ZnS.

[0158] The concentrator has a number of practical advantages. The concentrator is in use oriented so that it is substantially avoided that incoming radiation, that is emitted by regions of the atmosphere near the horizon, can reach the tube **214**. It is known that the atmospheric window is becoming less transmissive for radiation which travels through the atmosphere at a longer distance, such as radiation that is directed through the atmosphere near the horizon. Consequently, avoiding that that radiation can reach the particles improves the cooling efficiency. Further, the shape of the reflector portions **212** allows that the thermal radiation emitted from a lower portion of the tube **214** is directed to the atmosphere.

[0159] In addition, the reflector portion **212** comprise projecting wall portions that, together with the top cover **216**, avoid heating of the particles and the fluid by a hot breeze that may in use pass over the element **210**. In a variation of this embodiment the element **210** does not comprise the cover **216** and consequently the projecting wall portions of the reflector portions **212** will then alone have that function.

[0160] The cooling device according to any one of the described embodiments may also comprise a cover that may be suspended over a body portion or that is provided in the form of a cover layer that is in direct contact with the body portion. The cover is transmissive for the thermal radiation and protects the particles from hot breezes and other external influences that would reduce the cooling efficiency. The cover may also comprise a thermally insulating material. In one specific example, the cover comprises polyethylene and oxide or sulphide material, such as ZnS or iron oxide, which is positioned over the polyethylene material and also protects the polyethylene.

[0161] It will be appreciated that the alternatively the reflector portions **212** may have any other suitable shape, such as a parabolic dish and trough shape.

[0162] Referring now to FIG. **15**, a further example of a cooling device in accordance with a specific embodiment of the present invention is now described. FIG. **15 (a)** shows a cross-sectional view of a portion of a cooling device **220** and FIG. **15 (b)** shows a perspective view of a portion of the cooling device **220**. FIG. **15 (c)** shows a front view of the portion of the cooling device **220**.

[0163] In this embodiment, the portion of the cooling device **220** is arranged for mounting on a surface, such as an exterior surface of a building or structure. The cooling device **220** comprises tubular portions **222** which are arranged for directing a fluid. Further, the cooling device **220** comprises a thermally insulating material **224** which is arranged to reduce exchange of thermal energy between the fluid and an exterior of the portion of the cooling device **220**. The cooling device **120** also includes elements **226** for emission of thermal radiation. In this embodiment, the elements are provided in the form of coatings and are of the type as described above.

[0164] The cooling device **220** comprises further tubular portions (not shown) that direct the fluid to an interior portion of the building or structure where the fluid is enabled to absorb thermal energy. A pump (not shown) then directs the fluid from the interior portion of the building or structure to the exterior portion or structure where the elements **226** receive the thermal energy from the fluid and emit the received thermal energy in the form of thermal radiation. Consequently, the fluid is cooled by the elements **226**. The cooled fluid is then directed back into the interior of the building or structure and consequently results in cooling of the interior of the building or structure.

[0165] It is to be appreciated that the cooling device **220** may be used to cool the interior of shipping containers, office buildings, domestic buildings or any other type of structure building of structure. The portion of the cooling device **220** typically is mounted to the exterior portion of the building or structure so that the elements **226** are enabled to emit thermal radiation towards the sky.

[0166] FIGS. **16** and **17** show examples of portions of cooling devices **230** and **240**, respectively. The cooling devices **230** and **240** are arranged to operate in the same manner as the cooling device **220**. However, the cooling devices **230** and **240** comprise tubular portions **232** and **242**, respectively, which have a substantially square cross-sectional shape. The tubular portions **232** comprise elements for emission of thermal energy at top surfaces of the tubular portions **232**, which are slightly angled so that the elements are enabled to emit thermal radiation towards the sky.

[0167] The tubular portions **242** of the cooling device **242** also comprise elements for emission of thermal radiation at



top surfaces of the tubular portions, but in this case, the tubular portions are not angled and are located at differing distances relative to a wall **244** in a manner such that over-shadowing by upper tubular portions is reduced.

[0168] The portions of the cooling devices **220**, **230** and **240** typically are mounted at exterior portions of the buildings or structures which direct sunlight is reduced or avoided, as such location further increases the cooling efficiency.

[0169] FIG. **18** (a) shows components of a cooling device **250** according to an embodiment of the present invention and FIG. **18** (b) shows assembled components and a further component of the cooling device **250**. The cooling device **250** comprises a metallic body portion **252** and a lid-portion **254**. The lid-portion **254** comprises an element for emission of thermal radiation as described above. The body portion **252** is shaped so that a cavity is formed in which an article may be positioned and which is closed by the lid-portion **254** and a closure **256**. The body portion **252** is positioned in a thermally insulating shell **158**.

[0170] The cooling device further comprises a concentrator portion **255** which is in use positioned over the lid-portion **254**. In this example the concentrator portion **255** has a plurality of projecting wall portions that are arranged so that a plurality of smaller and substantially square concentrator areas are formed. The projecting wall portions are formed from a material that has a low thermal emittance and is reflective for the thermal radiation emitted by the particles. The projecting wall portions are arranged so that in use the thermal radiation is predominantly directed towards the Sky in a direction away from the horizon. Further, the projecting wall portions are positioned so that, in use, incoming radiation from regions of the atmosphere, which are near the horizon, is substantially blocked off.

[0171] For example, the cooling device **250** may be used for cooling food, liquids or any other matter that requires cooling. The articles are positioned in the cavity of the body portion **252**, which is then closed by the lid-portion **256**. The cooling device then cools the article by absorbing thermal energy from the article, which is then emitted by the element of the lid-portion **254**.

[0172] FIG. **19** shows components of a cooling system in accordance with an embodiment of the present invention. The cooling system **260** comprises of the cooling device **250**. Further, the cooling system **260** comprises a cooling container **262** having a lid-portion **264**. In this embodiment the cooling device **250** is arranged to cool liquid-filled elements **266**. For example, the liquid-filled elements **266** may be provided in the form of water-filled containers or bags. The cooling device **250** is then used to cool the liquid-filled elements **266** so that ice is formed within the elements **266**. The elements **266** are then removed from the cooling device **250** and positioned in cavities of the food container **262**. Articles that require cooling, such as food items, may then be positioned in the cooling container **262** which is then closed by the lid-portion **264**.

[0173] Referring now to FIG. **20**, a cooling device in accordance with another embodiment of the present invention is now described. FIG. **20** shows a cooling device **270** which comprises housing portions **272** and **274**. The housing portions **272** and **274** comprise thermally insulated wall portions **276** and **278**, respectively. In this embodiment, the housing portions **272** and **274** comprise threaded portion **280** and **282**, which are arranged for mechanically coupling the housing portions **272** and **274** with each other. The housing portion

**272** further comprises an element **284** having particles for emission of thermal radiation within the atmospheric window wavelength range. The element **284** is of the type as described above. Further, the housing portion **272** comprises a projecting wall portion **286** that is in this embodiment composed of a metallic material, such as aluminium, which has a relatively high thermal conductivity.

[0174] The wall portion **286** is arranged to receive a container, such as a beverage can. The can is in use positioned within the projecting wall portion **286**, which in turn is located within the housing portion **274** when the housing portions **272** and **274** are coupled to each other. The can typically is in thermal contact with the element **284** and the wall portion **286**. The element **284** is arranged to cool the wall portion **286** and the can. Once the can has been cooled, the housing portion **272** is separated from the housing portion **274** in a manner such that the can remains in the housing portion **274**, which continues to provide thermal insulation.

[0175] In this embodiment, the housing portion **272** is taller than the can and the element **284** is positioned below an upper portion of the housing portion **272** so that in use the likelihood of incidence of direct sunlight onto the element **284** is reduced. Further, the housing portion **272** is sufficiently tall so that in use incoming radiation from regions of the atmosphere, which are near the horizon, is substantially blocked off. The housing portion **272** also comprises an interior wall portion **288** that is reflective for the thermal radiation emitted by the particles and is in use positioned so that thermal radiation emitted by the particles is directed in a direction towards Space and in a direction away from the horizon. Interior wall portions of the housing portion **274** comprise a material that has low thermal emittance.

[0176] In use, the particles of the element **284** absorb thermal energy from the can positioned at the element **284** and within the projecting wall portion **286**. The absorbed thermal energy is emitted in the form of thermal radiation having a wavelength range within the atmospheric wavelength range. The housing portions **272** and **274** provide thermal insulation and consequently facilitate cooling of the can.

[0177] It is to be appreciated, however, that the cooling device **270** may be provided in various different forms. For example, the cooling device **270** may not necessarily be arranged to receive a can, but may alternatively be any other type of object. In addition, the housing portions **272** and **274** may have any suitable shape.

[0178] Although the invention has been described with reference to particular examples, it will be appreciated by those skilled in the art that the cooling device may also be arranged to facilitate operation of another device so that a "hybrid" device is formed. The cooling device may be arranged to cool a fluid, especially during the night, which is then used to facilitate heat exchange of a refrigerator or an air-conditioning device. In one variation the cooling device is arranged to store the cooled for a period of time, for example during the night.

[0179] Further, it is to be appreciated that in variations of the above-described embodiments the element of the cooling device may not necessarily comprise particles that are arranged for emission of thermal radiation having a wavelength within the atmospheric window wavelength range, but the particles may be replaced by at least one layer, such as a multi-layered structure, that is arranged for emission of thermal radiation having a wavelength within the atmospheric window wavelength range. The layers of the multi-layered



structure typically have thicknesses that are selected so that in use ionic surface plasmon resonances are generated and the ionic surface plasmon resonances have a wavelength or wavelength range within the atmospheric window wavelength range. For example, the multi-layered structure may comprise SiO and SiC layers having a thickness of the order of 50-150 nm. Alternatively, the particles may be replaced by grains of a layer having a granular structure, such as a suitable SiC layer. In this case an average diameter of the grains is selected so that the layer is arranged for emission of thermal radiation having a wavelength within the atmospheric window wavelength range. The particles may also be replaced by a porous layer or a layer having a rough surface such as a suitable SiC layer. In this case an average pore spacing or a surface profile, respectively, is selected so that the layer is arranged for emission of thermal radiation having a wavelength within the atmospheric window wavelength range.

[0180] In addition, it is to be appreciated that the element of the cooling device may comprise the above-described particles in addition to the above-described at least one layer. The at least one layer and the particles may both be arranged for emission of thermal radiation having a wavelength range within the atmospheric window wavelength range.

1. An element for emission of thermal radiation, the element comprising a component arranged for receiving thermal energy and emitting at least a portion of the received thermal energy in the form of the thermal radiation, the thermal radiation predominantly having a wavelength or wavelength range within an atmospheric window wavelength range in which the atmosphere of the Earth has a reduced average absorption and emission compared with an average absorption and emission in an adjacent wavelength range whereby absorption by the element of radiation from the atmosphere is reduced.

2. The element of claim 1 wherein the atmospheric window wavelength range includes a minimum of the average absorption of the atmosphere of the Earth.

3. The element of claim 1 wherein the atmospheric window wavelength range is a wavelength range from 3 to 5  $\mu\text{m}$  and/or from 7.9  $\mu\text{m}$  to 13  $\mu\text{m}$ .

4. The element of claim 1 wherein the element comprises particles arranged for receiving thermal energy and emitting at least a portion of the received thermal energy in the form of the thermal radiation.

5. The element of claim 1 wherein the element comprises a layer arranged for receiving thermal energy and emitting at least a portion of the received thermal energy in the form of the thermal radiation.

6. The element of claim 4 wherein the particles are distributed throughout the element and the element also comprises a material that is substantially transmissive for radiation having a wavelength within the atmospheric window range.

7. The element of claim 1 comprising a cover that is substantially transmissive for the thermal radiation and that is arranged for reduction of exchange of thermal energy by convection.

8. The element of any claim 7 comprising wall portions that define an interior space within which a medium that is to be cooled is in use located.

9. The element of claim 8 wherein the wall portions comprise a reflective material.

10. The element of claim 8 wherein at least some of the wall portions are thermally insulating.

11. The element of claim 1 comprising a structure that has projecting wall portions which are positioned so that, in use, incoming radiation from regions of the atmosphere, which are near the horizon, is substantially blocked off.

12. The element of claim 1 comprising a structure that has projecting wall portions that are reflective for the thermal radiation emitted by the component arranged for receiving thermal energy and emitting at least a portion of the received thermal energy in the form of the thermal radiation.

13. The element of claim 12 wherein the projecting wall portions are positioned so that in use the emitted thermal radiation is directed in a direction towards Space and in a direction away from the horizon.

14. The element of claim 1 any one of comprising a concentrator for concentrating radiation.

15. The element of claim 1 wherein the element is substantially transparent for visible light.

16. The element of claim 1 wherein the element comprises a substantially transparent polymeric material that comprises the component for emission of the thermal radiation and wherein the element is arranged so that in use at least a portion of the incoming near infrared radiation is absorbed and the resulting absorbed thermal energy is at least partially re-emitted in the form of thermal radiation by the component arranged for emission of radiation having a wavelength within the atmospheric window wavelength range.

17. The element of claim 1 wherein the element forms a part of an object.

18. A cooling system comprising thermally insulating wall portions and comprising the element of claims 1 wherein the cooling system is arranged for cooling an object that is positionable in, and removable from, an interior formed by the thermally insulating wall portion.

19. A cooling device for cooling a medium, the cooling device comprising an element for emission of thermal radiation, the element comprising particles arranged for receiving thermal energy and emitting at least a portion of the received thermal energy in the form of the thermal radiation, the thermal radiation predominantly having a wavelength or wavelength range within an atmospheric window wavelength range in which the atmosphere of the Earth has a reduced average absorption and emission compared with an average absorption and emission in an adjacent wavelength range whereby absorption by the element of radiation from the atmosphere is reduced.

20. The cooling device of claim 19 wherein the cooling device is arranged so that the medium is in indirect thermal contact with the element.

\* \* \* \* \*