



(19) **United States**

(12) **Patent Application Publication**  
Nies et al.

(10) **Pub. No.: US 2010/0143122 A1**

(43) **Pub. Date: Jun. 10, 2010**

(54) **ACTIVE FLOW CONTROL SYSTEM FOR WIND TURBINE**

**Publication Classification**

(76) Inventors: **Jacob Johannes Nies**, Zwolle (NL); **Wouter Haans**, Den Haag (NL)

(51) **Int. Cl.**  
*F03D 7/00* (2006.01)  
*F03D 11/00* (2006.01)  
(52) **U.S. Cl.** ..... **416/1**; 416/31; 416/90 R

(57) **ABSTRACT**

Correspondence Address:  
**PATRICK W. RASCHE (22402)**  
**ARMSTRONG TEASDALE LLP**  
**ONE METROPOLITAN SQUARE, SUITE 2600**  
**ST. LOUIS, MO 63102-2740 (US)**

An active flow control (AFC) system for use with a wind turbine is provided. The wind turbine includes at least one rotor blade having at least one manifold extending at least partially therethrough and at least one aperture defined through a surface of the at least one rotor blade. The at least one aperture is in flow communication with the at least one manifold. The AFC system includes an air intake duct configured to draw ambient air into the wind turbine, a self-cleaning air filter coupled in flow communication with the air intake duct and configured to filter the ambient air, and an AFC distribution system configured to eject the filtered air through the at least one aperture.

(21) Appl. No.: **12/613,157**

(22) Filed: **Nov. 5, 2009**

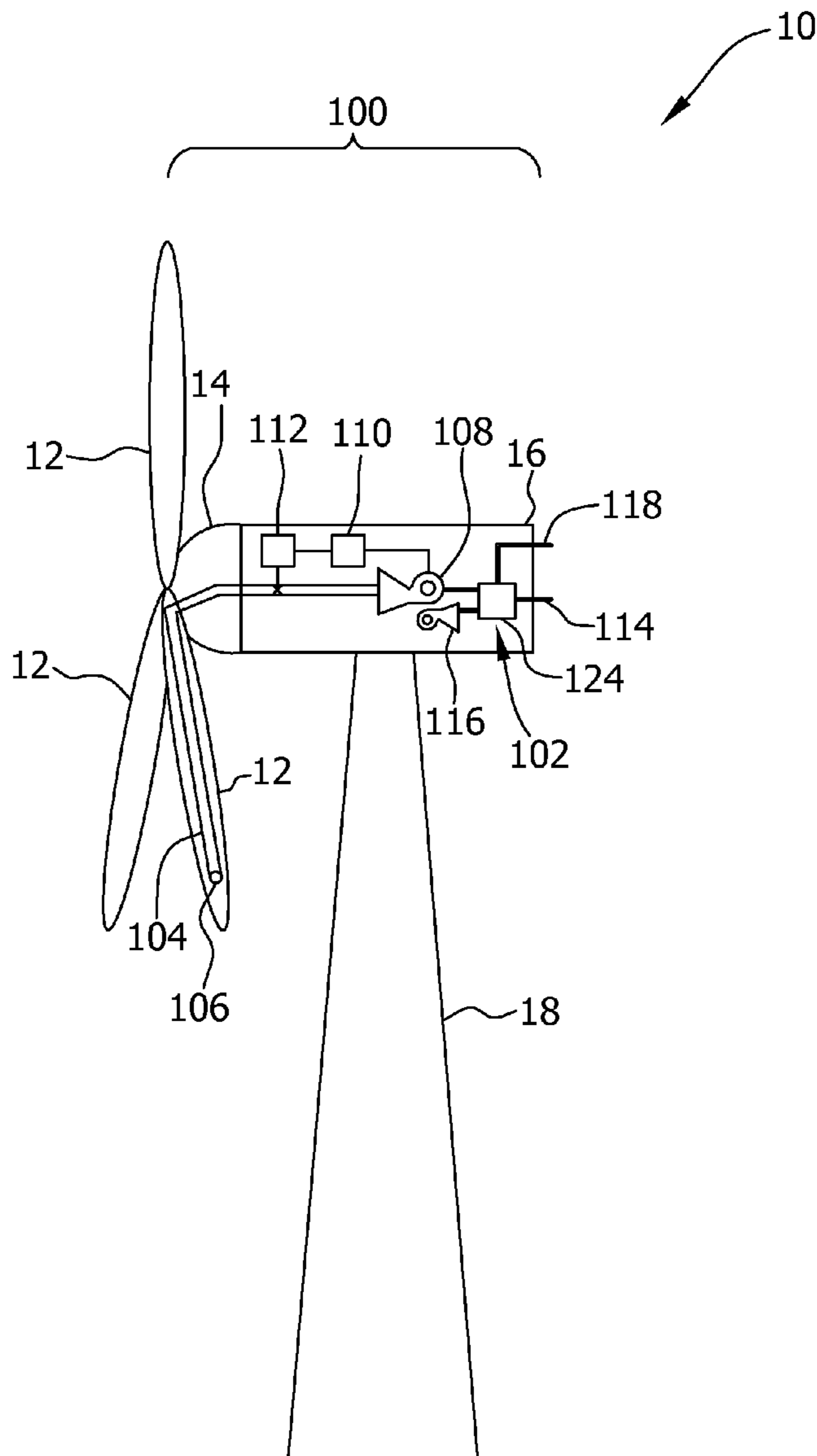

FIG. 1

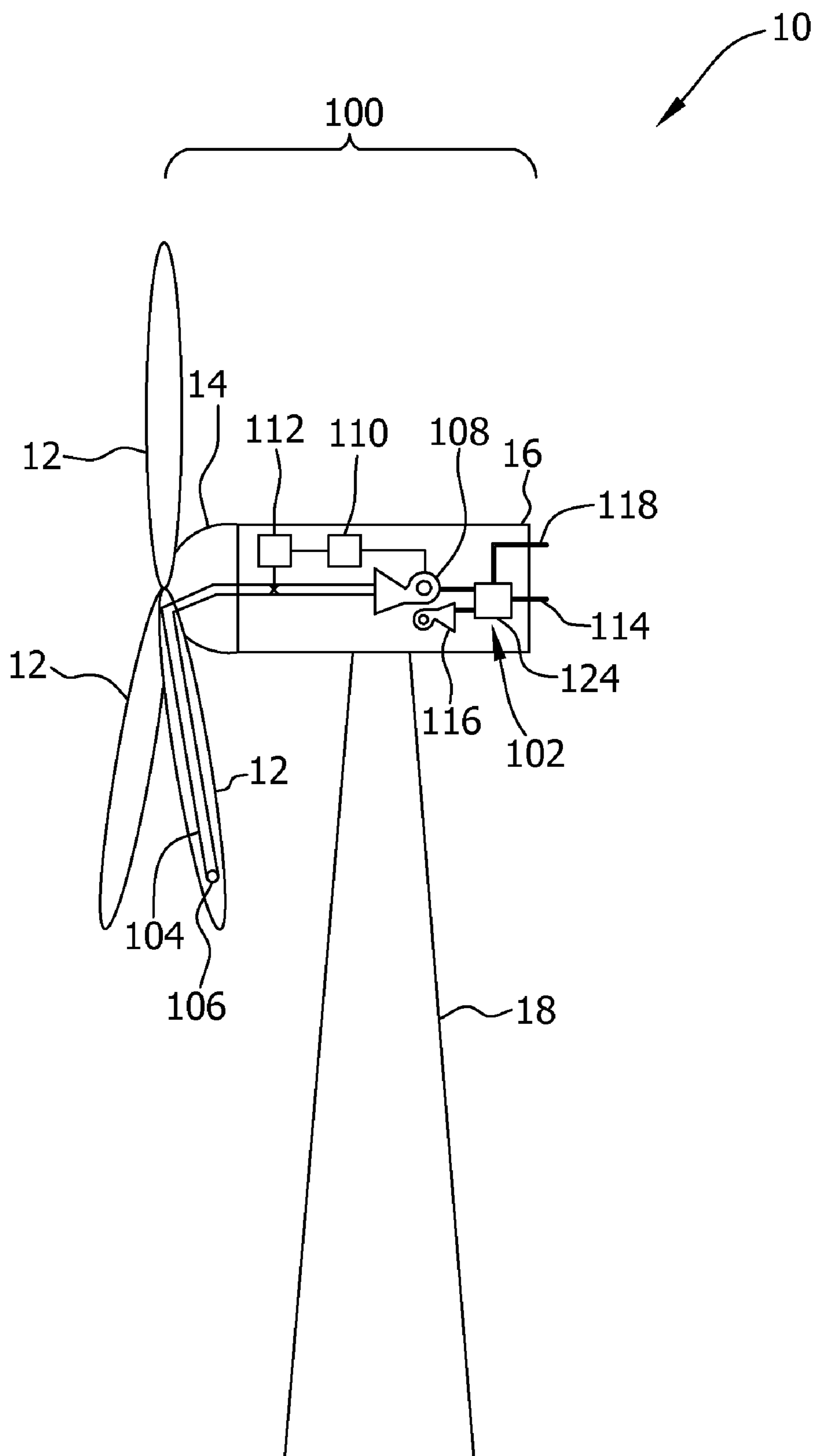

FIG. 2

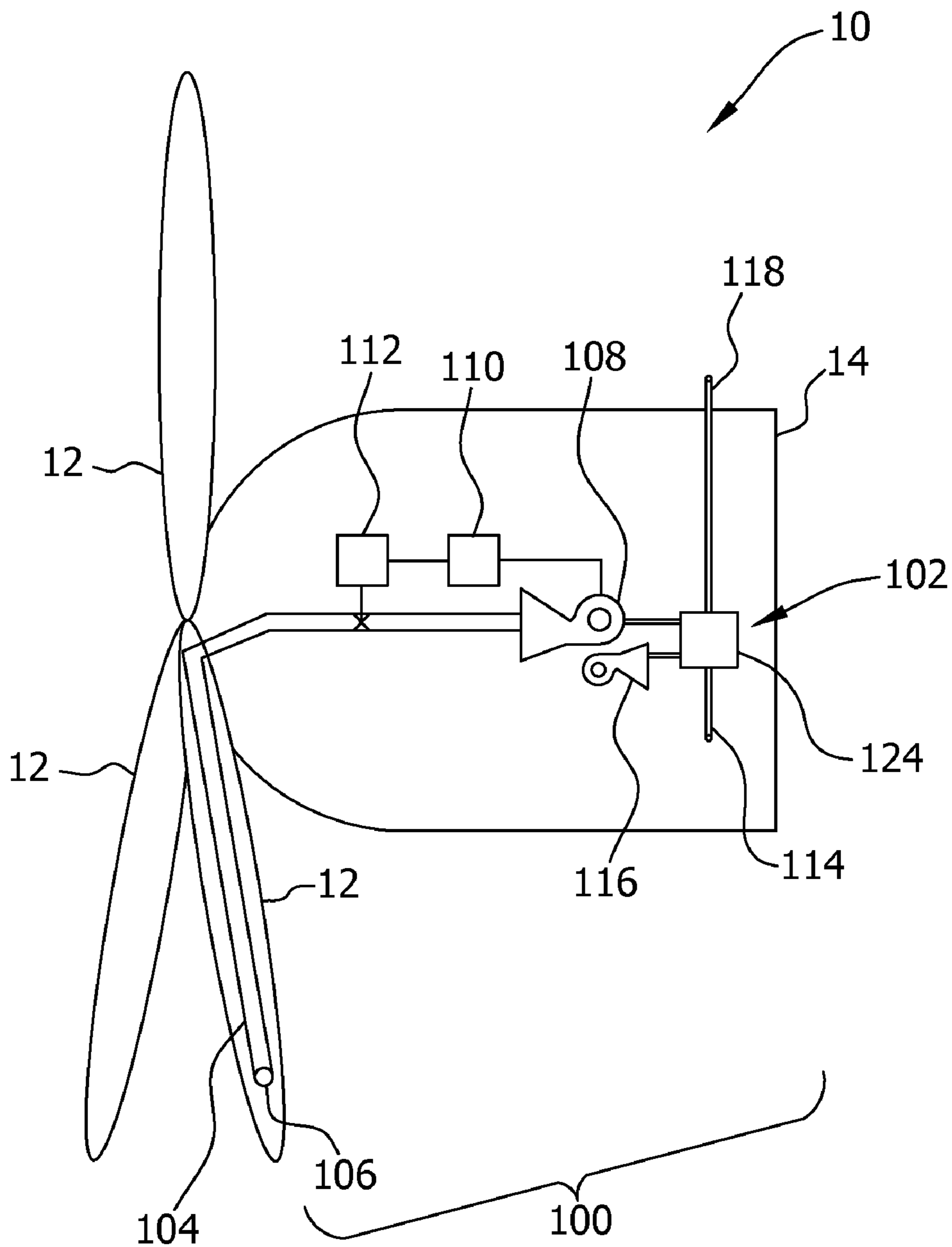

FIG. 3

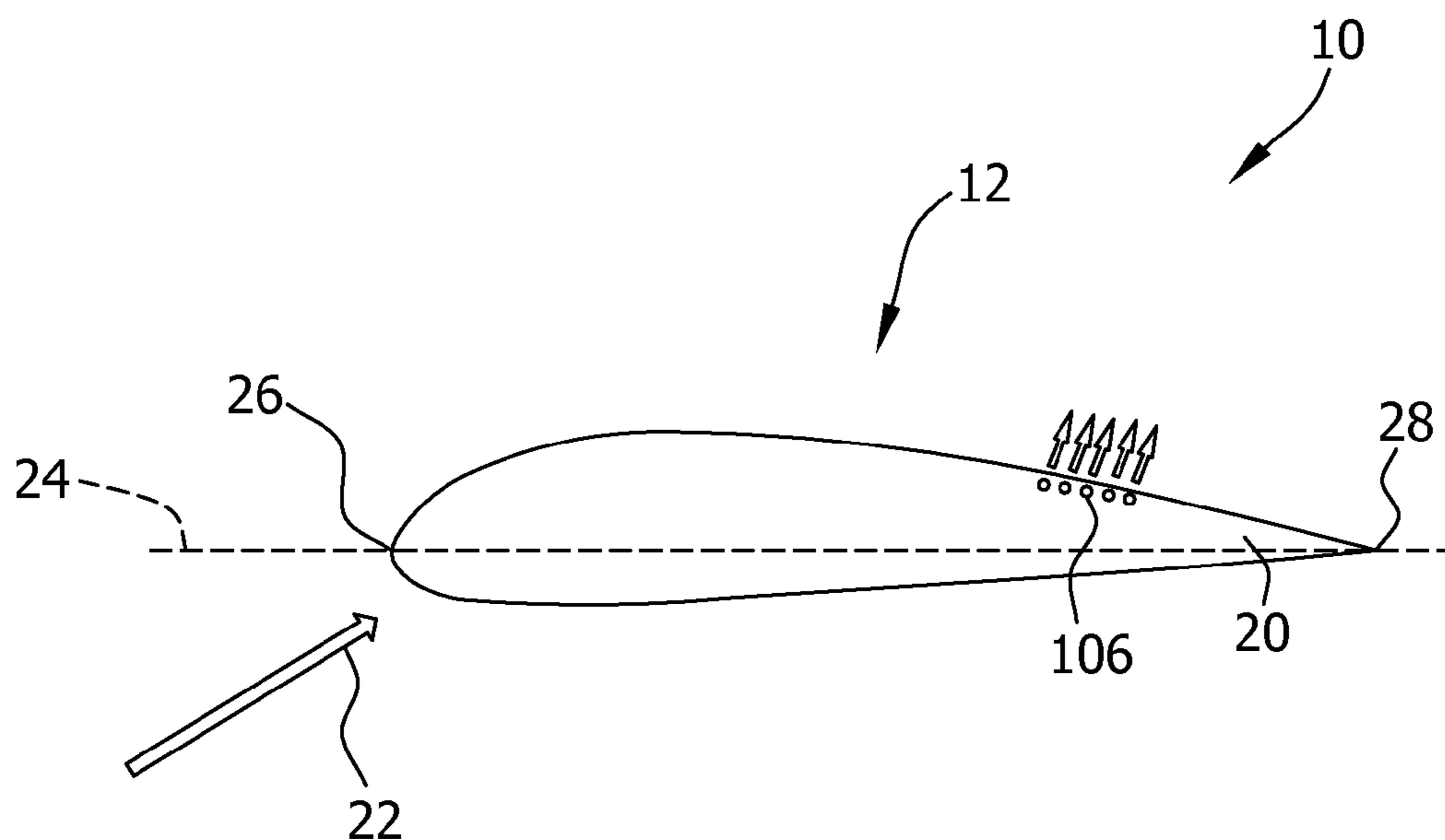

FIG. 5

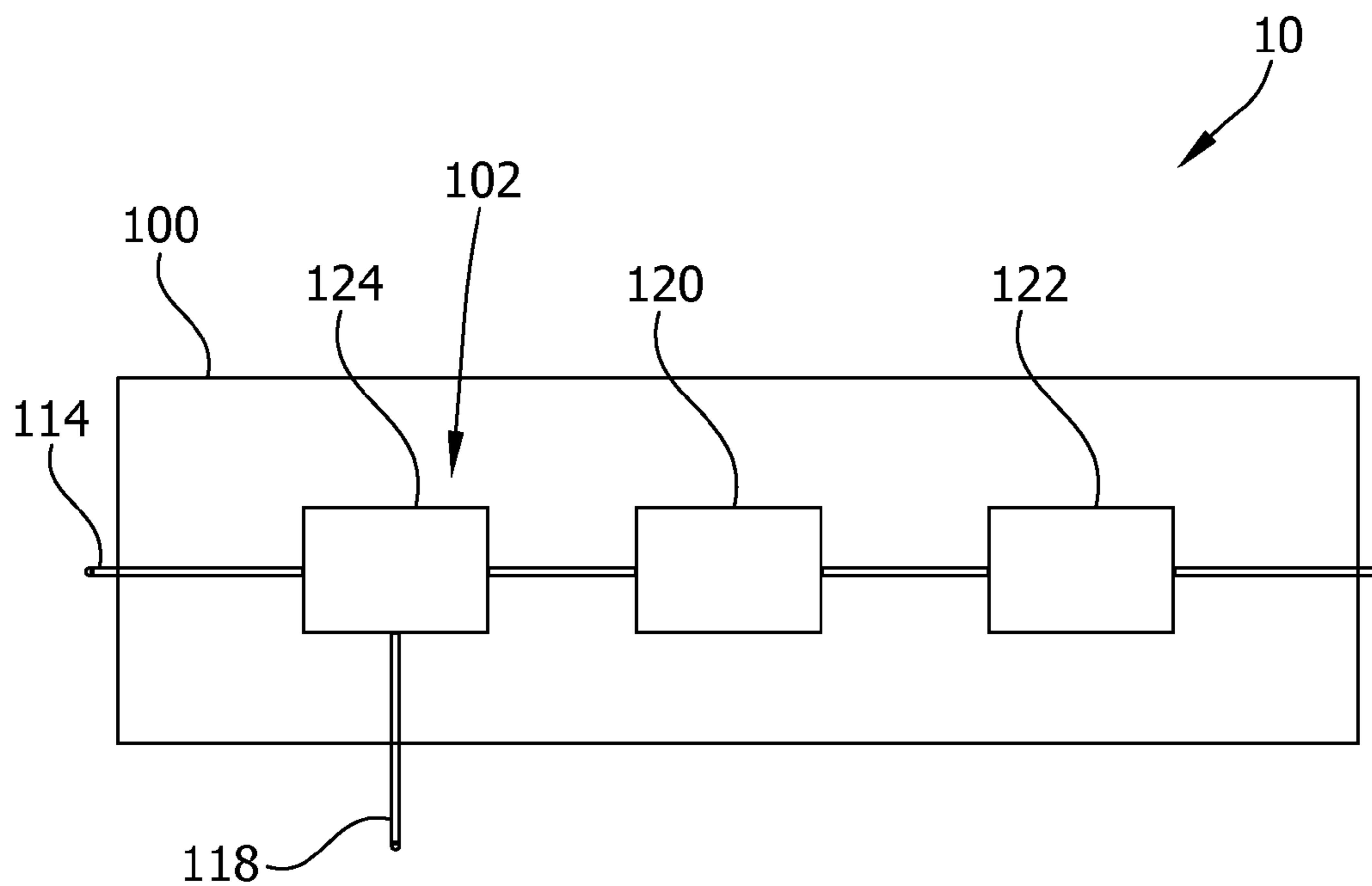

FIG. 4

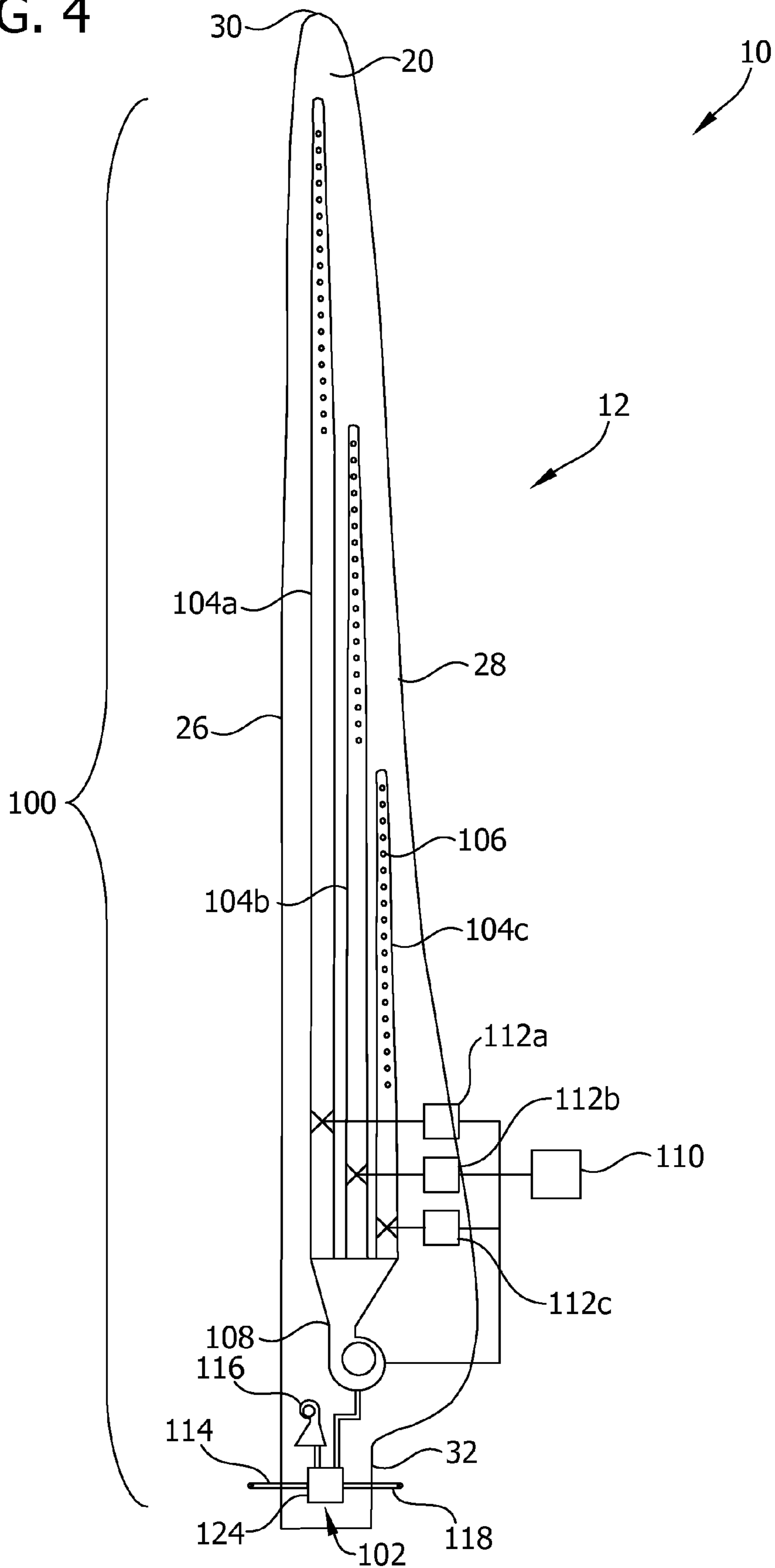
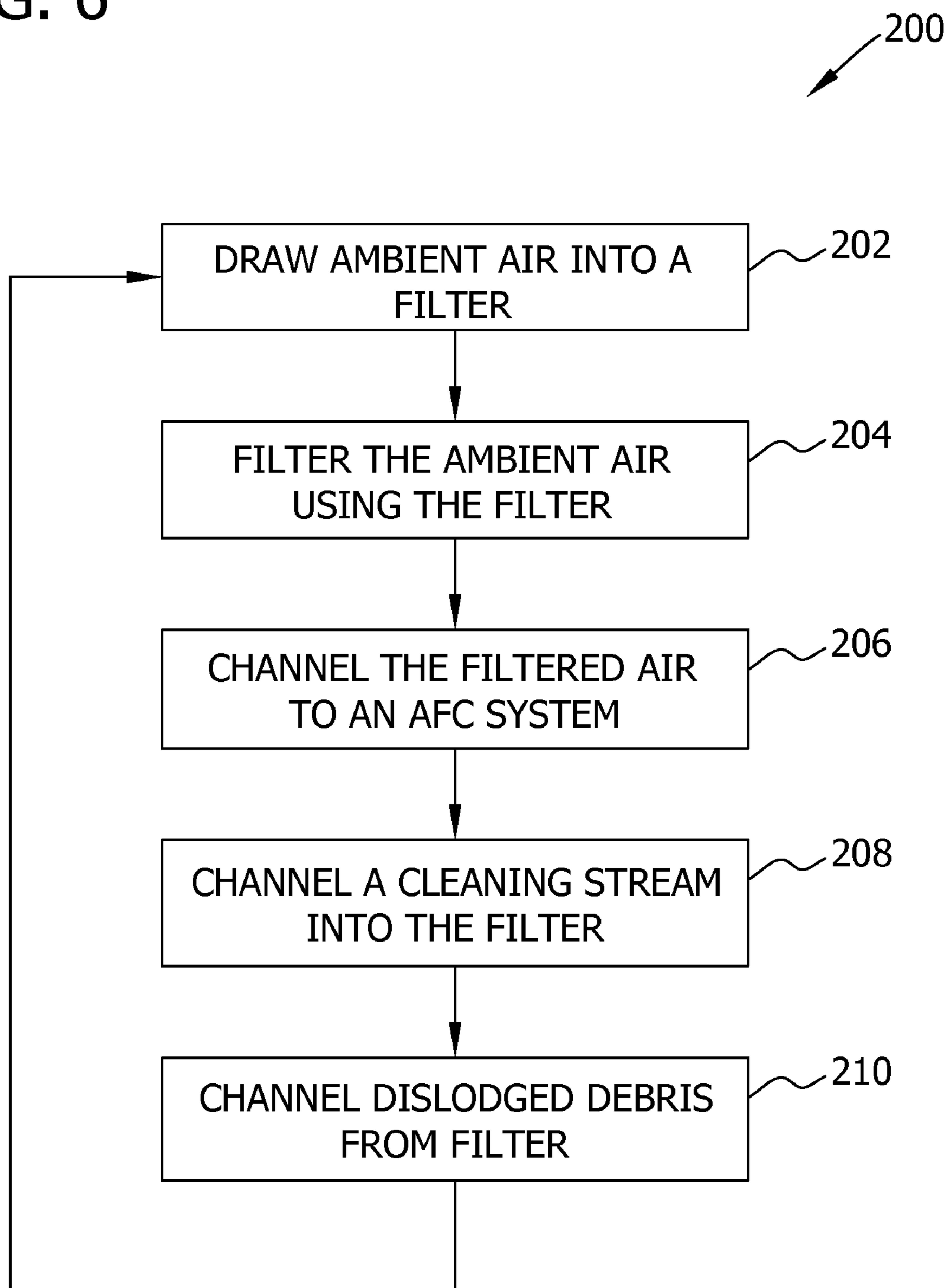

FIG. 6



## ACTIVE FLOW CONTROL SYSTEM FOR WIND TURBINE

### CROSS-REFERENCE TO RELATED APPLICATIONS

[0001] Cross-reference is hereby made to related, commonly assigned, co-pending applications: docket number 235606 entitled "Method for Operating a Wind Turbine with Reduced Blade Fouling," docket number 235625 entitled "Systems and Methods for Assembling an Air Distribution System for Use in a Rotor Blade of a Wind Turbine," docket number 235850 entitled "Systems and Method for Operating a Wind Turbine Having Active Flow Control," docket number 235851 entitled "Apparatus and Method for Cleaning an Active Flow Control (AFC) System of a Wind Turbine," docket number 235852 entitled "Systems and Method for Operating an Active Flow Control System," docket number 235854 entitled "Systems and Method for Operating a Wind Turbine Having Active Flow Control." Each cross-referenced application is invented by Jacob Johannes Nies and Wouter Haans and is filed on the same day as this application. Each cross-referenced application is hereby incorporated by reference in its entirety.

### BACKGROUND OF THE INVENTION

[0002] The present disclosure relates to wind turbines. Particularly, the present disclosure relates to an active flow control (AFC) system for use with a wind turbine, a wind turbine rotor blade including such an AFC system, and a wind turbine including such a rotor blade.

[0003] Although horizontal axis wind turbines are well-established these days, there is still considerable engineering effort going on to further improve their overall efficiency, robustness, and power generating capability.

[0004] This research has led to the most recent AFC technologies, which aim to improve wind turbine efficiency. AFC technologies try to avoid flow separation over rotor blades by actively modifying the wind flow proximate to the rotor blade. This can be achieved by blowing air through apertures on the surface of the rotor blade.

[0005] The introduction of such AFC systems has brought about the fact that the apertures used for blowing air eventually collect dirt or impurities. This phenomenon is one aspect of what is referred to as "blade fouling." Blade fouling can substantially lower the performance, in particular the extracted power of wind turbines.

[0006] Many wind turbines are located at remote places, e.g. offshore or in deserts. As service intervals are at minimum half a year with the tendency to get longer, there is a need to keep such an AFC system of a wind turbine clean over a long period of time with a minimum maintenance effort.

### BRIEF DESCRIPTION OF THE INVENTION

[0007] In one aspect, an active flow control (AFC) system for use with a wind turbine is provided. The wind turbine includes at least one rotor blade having at least one manifold extending at least partially therethrough and at least one aperture defined through a surface of the at least one rotor blade. The at least one aperture is in flow communication with the at least one manifold. The AFC system includes an air intake duct configured to draw ambient air into the wind turbine, a self-cleaning air filter coupled in flow communication with the air intake duct and configured to filter the ambient air, and

an AFC distribution system configured to eject the filtered air through the at least one aperture.

[0008] In another aspect, a wind turbine is provided. The wind turbine includes a rotor blade, at least one manifold extending at least partially through the rotor blade, an air intake duct configured to draw ambient air into the wind turbine, a gas supply coupled in flow communication with the at least one manifold and configured to supply gas to the at least one manifold, and a self-cleaning air filter coupled in flow communication with the air intake duct and the gas supply.

[0009] The self-cleaning air filter is configured to filter the ambient air channeled the filtered air to the gas supply.

[0010] In yet another aspect, a method for operating a wind turbine is provided. The wind turbine includes an active flow control (AFC) system having a self-cleaning air filter. The method includes drawing ambient air into the self-cleaning air filter such that debris is collected within the self-cleaning air filter, channeling a cleaning air stream into the self-cleaning air filter to dislodge the debris collected within the self-cleaning air filter, and channeling the dislodged debris from the self-cleaning air filter and away from the wind turbine.

[0011] Further aspects, advantages, and features of the embodiments described herein are apparent from the dependent claims, the description, and the accompanying drawings.

### BRIEF DESCRIPTION OF THE DRAWINGS

[0012] A full and enabling disclosure including the best mode thereof, to one of ordinary skill in the art, is set forth more particularly in the remainder of the specification, including reference to the accompanying figures wherein:

[0013] FIG. 1 is a schematic side view of an exemplary wind turbine.

[0014] FIG. 2 is a schematic side view of an exemplary rotor hub that may be used with the wind turbine shown in FIG. 1.

[0015] FIG. 3 is a chord-wise cross sectional view of an exemplary rotor blade that may be used with the wind turbine shown in FIG. 1.

[0016] FIG. 4 is a schematic longitudinal cross sectional view of the rotor blade shown in FIG. 3.

[0017] FIG. 5 is a schematic view of an exemplary AFC system that may be used with the wind turbine shown in FIG. 1.

[0018] FIG. 6 is a flowchart of an exemplary method that may be used to operate the wind turbine shown in FIG. 1.

### DETAILED DESCRIPTION OF THE INVENTION

[0019] Reference will now be made in detail to the various embodiments, one or more examples of which are illustrated in each figure. Each example is provided by way of explanation and is not meant as a limitation. For example, features illustrated or described as part of one embodiment can be used on or in conjunction with other embodiments to yield yet further embodiments. It is intended that the present disclosure includes such modifications and variations.

[0020] Modern wind turbines are designed to produce a maximum amount of energy in a particular geographical area. However, if the wind speed becomes too large, and therefore changes an angle of attack above a certain value, flow separation over wind turbine blades occurs and results in stall. In such a situation energy production by the wind turbine is reduced or even prevented. By delaying the flow separation

over wind turbine blades, the design of the wind turbine can be favorably changed, e.g. to increase an operational wind speed range and/or to change design parameters, such as chord and/or rotor diameter. This will eventually result in a considerable increase of wind turbine energy production.

[0021] Flow separation over wind turbine blades can be delayed by blowing gas out of small apertures defined through a surface of the rotor blade. The gas may be supplied to the apertures through manifolds in the rotor blade via a gas supply. Various gases may be used, such as, but not limited to, air, nitrogen, and/or carbon dioxide. If the term “air” is used in the following description, this is done without any intention to limit the scope of the appended claims. The gas flow rate through the manifolds and out of the apertures is controlled by the gas supply and valves. By controlling a gas flow rate, aerodynamic properties of the rotor blade can be changed, resulting in a delayed flow separation. The system, including the gas supply, valves, manifolds, and apertures, actively controls the gas flow out of the apertures of the rotor blade. This system is sometimes called an active flow control (AFC) system. Accordingly, the apertures are sometimes called AFC apertures.

[0022] According to the embodiments disclosed herein, blade fouling, particularly fouling of a manifold included inside a rotor blade, is avoided by filtering the ambient air that is channeled from an gas supply into the manifold. “Ambient air” is understood to particularly include the air around and near the gas supply, or near or inside the wind turbine. In particular, the ambient air can be taken from inside a rotor blade, from inside a rotor hub, a nacelle, and/or a wind turbine tower. Additionally or alternatively, the ambient air may be taken from outside the wind turbine. An air intake duct is used to take in the ambient air.

[0023] By filtering the ambient air used by the gas supply as described herein, fewer impurities get into the manifolds of the wind turbine in the first place. The filtering described herein results in reduced fouling of the rotor blades, particularly an AFC system at least partially defined within the rotor blade, and more particularly the manifolds of the AFC system.

[0024] FIG. 1 shows an exemplary wind turbine 10 having an AFC system 100, including a self-cleaning air filter 102. Wind turbine 10 includes three rotor blades 12, but may also have more or less than three rotor blades 12. Rotor blades 12 are mounted on a rotor hub 14, which is connected to a nacelle 16 that is fixed on a top of a tower 18.

[0025] In the exemplary embodiment, each rotor blade 12 includes at least one manifold 104 which is connected to an aperture 106 defined through a surface 20 of rotor blade 12. For reasons of simplicity, only one rotor blade 12 having manifold 104 and aperture 106 is depicted. However, any rotor blade 12 of wind turbine 10 can include manifolds 104 and apertures 106. At an upstream end of manifold 104, each manifold 104 is connected to a gas supply 108 from which air is supplied to manifolds 104. In operation, gas supply 108 supplies air to manifolds 104 which is then ejected through apertures 106.

[0026] Each rotor blade 12 includes, in the exemplary embodiment, at least one manifold 104 that is in flow communication with at least one aperture 106. An air flow rate through manifolds 104 is controlled by an AFC controller 110 and/or a wind turbine controller, which may be combined or separate components of wind turbine 10. In a particular embodiment, AFC controller 110 controls the air flow rate

through manifolds 104 by changing an air flow rate of gas supply 108. In an additional or alternative embodiment, AFC controller 110 controls the air flow rate through manifolds 104 by blocking one manifold 104 of wind turbine 10, thereby increasing the air flow rate through unblocked manifolds 104. This may be used for changing the ejection pattern of the ejected air to change the aerodynamic properties of rotor blade 12. In order to block manifolds 104, AFC controller 110 uses at least one valve 112. As apertures 106 are connected to manifolds 104, the air flow rate through apertures 106 can be controlled by controlling the air flow rate through manifolds 104. According to both embodiments described above, AFC controller 110 can change the aerodynamic properties of rotor blade 12, which typically results in delaying the flow separation over rotor blades 12.

[0027] FIG. 2 shows rotor hub 14 that may be used wind turbine 10 (shown in FIG. 1). In the exemplary embodiment, rotor hub 14 includes at least a portion of AFC system 100. AFC system 100 includes an air intake duct 114, self-cleaning air filter 102, a pressurized air device 116, an exhaust valve 118, gas supply 108, valves 112, AFC controller 110, manifolds 104, and apertures 106, as described in more detail below.

[0028] FIG. 3 is a chord-wise cross-sectional view of rotor blade 12 being equipped with AFC system 100. FIG. 4 shows a longitudinal cross sectional view of rotor blade 12. Positions of AFC apertures 106 are shown in FIG. 3. Further, in FIG. 3, rotor blade 12 is seen along a span-wise axis of rotor blade 12. In typical situations, a wind direction 22 impinges rotor blade 12 at an area slightly above where a chord line 24 intersects rotor blade 12 at a leading edge 26.

[0029] Aerodynamic properties of rotor blade 12 are changed by ejecting air through apertures 106 on surface 20 of rotor blade 12 on its suction side. Apertures 106 are typically positioned on the suction side of rotor blade 12 downwind of an airfoil maximum thickness.

[0030] Rotor blade 12 has leading edge 26 on a left hand side of FIG. 4 and a trailing edge 28 on a right hand side of FIG. 4. In the exemplary embodiment, rotor blade 12 includes AFC system 100, which includes gas supply 108 and manifolds 104a, 104b, and 104c. Alternatively, rotor blade 12 may include one or more manifolds 104 extending therethrough. In the exemplary embodiment, gas supply 108 supplies air to manifolds 104a, 104b, and 104c, which are connected in parallel to gas supply 108.

[0031] Manifold 104a closest to leading edge 26 is longest manifold 104 and extends almost until a tip 30 of rotor blade 12. Manifold 104c extends to about half of a longitudinal length of rotor blade 12. A length of middle manifold 104b roughly equals an arithmetic average of outer manifolds 104a and 104c. Specific properties of rotor blade 12 described herein are only exemplary. Typically a number of manifolds 104 or apertures 106 of rotor blade 12 may be different from the example shown in FIG. 4. For example, the lengths and/or widths of manifolds 104a, 104b, and/or 104c and/or positions of manifolds 104a, 104b, and/or 104c within rotor blade 12 may vary.

[0032] The air flow channeled from gas supply 108 into each of manifolds 104a, 104b, and/or 104c may be blocked by valves 112a, 112b, and/or 112c arranged at or in an onset of manifolds 104a, 104b, and/or 104c after junctions of gas supply 108 and manifolds 104a, 104b, and/or 104c. Valves 112a, 112b, and 150c correspond to and are operatively coupled to manifolds 104a, 104b, and 104c, respectively.



Each manifold **104a**, **104b**, and/or **104c** is connected to a respective set of apertures **106**. Valves **112a**, **112b**, and **112c** and AFC controller **110** are depicted at least partly outside rotor blade **12** for clarity reason. However, valves **112a**, **112b**, and/or **112c** and/or AFC controller **110** are typically arranged inside rotor blade **12**, inside rotor hub **14**, or inside nacelle **16**.

[0033] An air flow rate through manifolds **104a**, **104b**, and/or **104c** is controlled by AFC controller **110**. In the exemplary embodiment, AFC controller **110** controls the air flow rate through manifolds **104a**, **104b**, and/or **104c** by changing an air flow rate of gas supply **108**. Alternatively or additionally, AFC controller **110** controls an air flow rate through manifolds **104a**, **104b**, and/or **104c** by blocking, e.g. manifold **104a**, thereby increasing the air flow rate through unblocked manifolds **104b** and **104c**. For blocking manifolds **104a**, **104b**, and/or **104c**, AFC controller **110** may use valves **112a**, **112b**, and/or **112c**. Each valve **112a**, **112b**, and **112c** can be continuously adjusted from completely open to completely closed. It is to be understood that the term “blocking” does not necessarily mean complete blocking, but may also imply partial blocking of manifolds **104a**, **104b**, and/or **104c**. Valves **112a**, **112b**, and/or **112c** thus have a flow control function. If a valve **112a** is not closed completely, the gas flow through other valves **112b** and **112c** is not increased to the same extent as compared to the case in which valve **112a** closes completely.

[0034] If it is intended to clean manifolds **104b** and **104c**, the gas flow through manifolds **104b** and **104c** needs to be large enough to ensure a cleaning action within manifolds **104b** and **104c**. For example, if the gas flow through manifolds **104b** and **104c** is not large enough, the gas flow rate of gas supply **108** may be increased and/or valve **112a** may be closed more completely. In both events, the gas flow through manifolds **104b** and **104c** may be increased beyond a value where the cleaning action is large enough to clean manifolds **104b** and **104c**. According to alternative embodiments, valves **112a**, **112b**, and/or **112c** may be replaced by other flow control devices that are adapted to control a gas flow through manifolds **104a**, **104b**, and/or **104c**. As apertures **106** are in flow communication with manifolds **104a**, **104b**, and **104c**, the air flow rate through apertures **106** can be controlled by controlling the air flow rate through manifolds **104a**, **104b**, and/or **104c**. According to both embodiments described above, AFC controller **110** can delay the flow separation over rotor blades **12** to change the aerodynamic properties of rotor blade **12**.

[0035] FIG. 5 is a schematic view of AFC system **100** that may be used with wind turbine **10** (shown in FIG. 1). In the exemplary embodiment, AFC system includes an AFC distribution system **120**. In one embodiment, AFC distribution system **120** is gas supply **108**. Gas supply **108** includes, without limitation, a pump, a pressure tank, a compressed gas cylinder, a compressor, a fan, a pumping device, a blower, and/or any other suitable device. In the exemplary embodiment, AFC distribution system **120** is configured to generate a cleaning air stream for cleaning self-cleaning air filter **102**.

[0036] AFC system **100** includes an air ejecting system **122** that, in the exemplary embodiment, is realized by manifolds **104**. Manifolds **104** are connected to AFC distribution system **120** on their upstream ends. On their downstream ends, manifolds **104** are connected to apertures **106** arranged on surface **20** of rotor blade **12**. In this context, the terms “upstream” and “downstream” refer to gas flow directions within AFC distribution system **120**. Accordingly, the term “downstream”

refers to a direction from AFC distribution system **120** towards air ejecting system **122**. In the exemplary embodiment, air ejecting system **122** ejects filtered air through apertures **106** on surface **20** of rotor blade **12**. Air which is blown out of rotor blade **12** improves the aerodynamic properties of rotor blade **12** by delaying flow separation as explained above. An air flow rate through manifolds **104** is controlled by an AFC controller **110**, as described above.

[0037] AFC system **100** includes air intake duct **114** to take in ambient air. More specifically, air intake duct **114** of AFC system **100** takes in ambient air and supplies that air to self-cleaning air filter **102**. As such, air intake duct **114** is in flow communication with self-cleaning air filter **102**. In the embodiment shown in FIG. 2, the ambient air is taken from inside rotor hub **14**, however, in alternative embodiments, the air is taken from the exterior of wind turbine **10**. This is typically done using air intake duct **114** as positioned, for example, in rotor hub **14**. According to the embodiment shown in FIG. 2, self-cleaning air filter **102** filters the ambient air and channels the filtered air to gas supply **108**, which is in flow communication with self-cleaning air filter **102**.

[0038] More specifically, air intake duct **114** is coupled in flow communication with self-cleaning air filter **102** that is configured to filter the ambient air. Self-cleaning air filter **102** is coupled in flow communication with AFC distribution system **120**, which channels filtered air from self-cleaning air filter **102** to air ejecting system **122**. More specifically, self-cleaning air filter **102** is in flow communication with gas supply **108** and the ambient air. Further, self-cleaning air filter **102** is, in the exemplary embodiment, located in a root **32** of rotor blade **12**. Root **32** may be fixed to rotor hub **14**.

[0039] Self-cleaning air filter **102** is any suitable filter that is configured to clean its filter element from time to time by removing impurities from the filter element of self-cleaning air filter **102**. In the exemplary embodiment, self-cleaning air filter **102** is realized as a back-flushing air filter **124**. Back-flushing air filter **124** is a specific type of self-cleaning air filter **102** that is able to clean its filter element by using a back-flushing air stream. To generate such a back-flushing air stream, typically compressed and/or pressurized air is used. This pressurized air flushes out the impurities which, e.g. are torn off a filter element of back-flushing air filter **124**. More specifically, the back-flushing air stream is used to tear off the impurities on or at the filter element, and then to flush the impurities into exhaust valve **118**. Exhaust valve **118** exhausts the dirt expelled from inside back-flushing air filter **124** to the outside of AFC system **100**. Thus, back-flushing air filter **124** can clean itself while simultaneously filtering air.

[0040] More specifically, in the exemplary embodiment, back-flushing air filter **124** coupled in flow communication with pressurized air device **116** that compresses the filtered air emerging from back-flushing air filter **124**. This compressed and/or pressurized air is then supplied back to back-flushing air filter **124** for use as the back-flushing air stream that cleans back-flushing air filter **124**. Alternatively or additionally, the back-flushing air stream is provided by gas supply **108**, which is configured to provide a back-flushing air stream. When gas supply **108** and pressurized air device **116** are used, gas supply **108** and pressurized air device **116** may alternately or simultaneously provide the back-flushing air stream.

[0041] In the exemplary embodiment, the filter element of self-cleaning air filter **102** is continuously cleaned by a stream of air. For example, self-cleaning air filter **102** includes an

inlet for the ambient air and an inlet for the back-flushing air stream opposite to the ambient air inlet. An impurities outlet, such as exhaust valve **118**, is positioned adjacent the ambient air inlet at a location to receive the back-flushing air stream. The filter element rotates about an axis positioned between the ambient air inlet and the back-flushing air stream inlet. As the filter element rotates, a portion of the filter elements collects impurities and/or debris entering self-cleaning air filter **102** through the ambient air inlet, and another portion is being cleaned by the back-flushing air stream dislodging debris and channeling the dislodged debris into the impurities outlet. Continuous and/or period self-cleaning maintains functioning of self-cleaning air filter **102** without need of maintenance and/or inspection. Furthermore, the filter function of self-cleaning air filter **102** is continuously provided in AFC system **100** or rotor blade **12**.

[0042] In the exemplary embodiment, self-cleaning air filter **102** is configured to determine a degree of clogging of the filter element of self-cleaning air filter **102**. Self-cleaning air filter **102** is further configured to clean the filter element of self-cleaning air filter **102** if the degree of clogging of the filter element exceeds a clogging threshold value. In one embodiment, the degree of clogging of the filter element is determined based on a pressure difference of self-cleaning air filter **102**. The pressure difference is determined as a difference in total pressure measured upstream and downstream of self-cleaning air filter **102**. The pressure difference thus serves as a measure for filter clogging. Ideally, the pressure difference of self-cleaning air filter **102** is zero or near zero, however the clogging threshold value at which self-cleaning air filter **102** is cleaned depends on characteristics of self-cleaning air filter **102**. The above-mentioned pressure difference can either be measured directly by a differential pressure measurement device and/or indirectly by measuring two pressure levels and subtracting them.

[0043] Referring to FIGS. **1**, **2**, **4**, and **5**, a position of exhaust valve **118** is chosen such that the impurities do not deposit on surface **20** of rotor blade **12** in order to prevent blade fouling. For example, as shown in FIG. **1**, impurities are exhausted from a rear of nacelle **16**; as shown in FIG. **2**, impurities are exhausted from a top of nacelle **16**; and, as shown in FIG. **4**, impurities are exhausted from root **32** and/or trailing edge **28** of rotor blade **12**. In embodiments in which AFC system **100** is located within nacelle **16**, the impurities are ejected through exhaust valve **118** on a lee or rear side of rotor blade **12**, hub **14**, and/or nacelle **16**. Thus, the wind will transport the dirt away from nacelle **16** and fouling of wind turbine **10** is prevented. In a particular embodiment, exhaust valve **118** ejects the impurities through a lateral side of rotor hub **14**. In alternative embodiments, exhaust valve **118** channels the impurities to tower **18**, nacelle **16**, and/or to rotor blade **12**. From there the impurities may be ejected to the exterior of wind turbine **10**.

[0044] Alternatively, the impurities are stored in a container (not shown) that is typically located within rotor hub **14** of wind turbine **10**. In such embodiments, exhaust valve **118** is in flow communication with the container. The container may be emptied or replaced with an empty container by maintenance personnel during a maintenance activity. Although being typically located at or in rotor hub **14**, the container for the impurities may also be located in nacelle **16**, in or at tower **18**, or in or at rotor blade **12**.

[0045] When the impurities are ejected into the air outside of wind turbine **10**, environmental conditions, such as a wind

direction, a wind speed, and/or a presence or absence of precipitation, are taken into account. Typically, the impurities are ejected at positions at trailing edge **28** of rotor blade **12** or at rotor blade root **32**, in the latter case either towards a connected rotor hub **14** or directly into the air outside rotor blade **12**.

[0046] FIG. **6** is a flowchart of a method **200** of operating wind turbine **10** (shown in FIG. **1**). By performing method **200**, fouling of blade **12** (shown in FIGS. **1-4**) and/or AFC system **100** (shown in FIGS. **1**, **2**, and **4**) is facilitated to be corrected and/or prevented. Method **200** is performed at least partially by the wind turbine controller and/or AFC controller **110** (shown in FIGS. **1**, **2**, and **4**) sending or transmitting commands and/or instructions to components of wind turbine **10**. The wind turbine controller and/or AFC controller **110** is programmed with code segments configured to perform method **200**. Alternatively, method **200** is encoded on a computer-readable medium that is readable by the wind turbine controller and/or AFC controller **110**. In such an embodiment, the wind turbine controller and/or AFC controller **110** is configured to read computer-readable medium for performing method **200**.

[0047] In the exemplary embodiment, method **200** is performed continuously or periodically according to a predetermined corrective schedule, a predetermined preventative schedule, condition-triggered automated operation, and/or condition-triggered manual operation. In a particular embodiment, the wind turbine controller and/or AFC controller **110** performs method **200** after the wind turbine controller, AFC controller **110**, and/or a human operator determines optimal conditions exist for performing method **200**. Alternatively, or additionally, the wind turbine controller and/or AFC controller **110** is configured to determine when fouling has occurred and/or will occur and perform method **200** upon making such a determination.

[0048] Referring to FIGS. **1-6**, method **200** includes drawing **202** ambient air into wind turbine **10** through self-cleaning air filter **102**. More specifically, ambient air is drawn **202** into self-cleaning air filter **102** through air intake duct **114**. The ambient air drawn **202** into self-cleaning air filter **102** is then filtered **204** using self-cleaning air filter **102**. For example, a filter element of self-cleaning air filter **102** collects debris entrained within the ambient air as the ambient air is channeled through self-cleaning air filter **102**.

[0049] The filtered air is channeled **206** to AFC system **100** of wind turbine **10** to change the aerodynamic properties of at least one rotor blade **12**, as described in more detail above. In the exemplary embodiment, the filtered air is channeled **206** to gas supply **108** of AFC system **100** for distribution in manifolds **104** of AFC system **100**. Alternately or simultaneously with channeling **206** the filtered air, a cleaning air stream is channeled **208** into self-cleaning air filter **102** to dislodge debris collected within self-cleaning air filter **102**. In the exemplary embodiment, the cleaning air stream is channeled **208** from pressurized air device **116** into self-cleaning air filter **102** as the back-flushing air stream described above. As the cleaning stream is channeled **208** through self-cleaning air filter **102**, debris collected therein, such as on the filter element, is dislodged and entrained in the cleaning air stream. As the debris becomes dislodged from self-cleaning air filter **102**, the debris is channeled **210** from self-cleaning air filter **102** and, thus, away from rotor blade **12** and/or wind turbine **10**. More specifically, the cleaning air stream having debris entrained therein is channeled **210** from self-cleaning air filter

**102**, through exhaust valve **118**, to an exterior of wind turbine **10** and/or to a container within wind turbine **10**.

[0050] Each step **202**, **204**, **206**, **208**, and/or **210** of method **200** may be performed continuously and/or simultaneously. For example, as described above, the filter element may be rotated within self-cleaning air filter **102** to collect debris with one portion of the filter element while cleaning debris from another portion of the filter element. Such continuous cleaning of self-cleaning air filter **102** prevents self-cleaning air filter **102** from becoming clogged with debris to such an extent that the cleaning air stream is not sufficient to substantially clean self-cleaning air filter **102**. However, the effectiveness of continuous or intermittent cleaning of self-cleaning air filter **102** is based on the characteristic of self-cleaning air filter **102**.

[0051] A technical effect of the systems and method described herein includes at least one of: (a) drawing ambient air into a self-cleaning air filter; (b) filtering ambient air using a self-cleaning filter; (c) channel filtered air to an AFC system from a self-cleaning air filter; (d) channeling a cleaning air stream into a self-cleaning air filter to dislodge debris collected within the self-cleaning air filter; and (e) channeling dislodged debris from a self-cleaning air filter and away from a rotor blade and/or a wind turbine.

[0052] This written description uses examples, including the best mode, to enable any person skilled in the art to make and use the described subject-matter. While various specific embodiments have been disclosed in the foregoing, those skilled in the art will recognize that the spirit and scope of the claims allows for equally effective modifications. Especially, mutually non-exclusive features of the embodiments described above may be combined with each other. The patentable scope is defined by the claims, and may include such modifications and other examples that occur to those skilled in the art. Such other examples are intended to be within the scope of the claims if they have structural elements that do not differ from the literal language of the claims, or if they include equivalent structural elements with insubstantial differences from the literal language of the claims.

What is claimed is:

**1.** An active flow control (AFC) system for use with a wind turbine, the wind turbine including at least one rotor blade having at least one manifold extending at least partially there-through and at least one aperture defined through a surface of the at least one rotor blade, the at least one aperture in flow communication with the at least one manifold, said AFC system comprising:

- an air intake duct configured to draw ambient air into the wind turbine;
- a self-cleaning air filter coupled in flow communication with said air intake duct and configured to filter the ambient air; and
- an AFC distribution system configured to eject the filtered air through the at least one aperture.

**2.** The AFC system according to claim **1**, wherein said self-cleaning air filter comprises a back-flushing air filter.

**3.** The AFC system according to claim **2**, wherein said back-flushing air filter is configured to be cleaned by a back-flushing air stream.

**4.** The AFC system according to claim **2**, wherein said AFC distribution system comprises a gas supply configured to provide the back-flushing air stream to said back-flushing air filter.

**5.** The AFC system according to claim **1**, wherein said self-cleaning air filter is configured to remove debris from a filter element of said self-cleaning air filter at regular intervals.

**6.** The AFC system according to claim **1**, wherein said self-cleaning air filter is configured to:

- determine a degree of clogging of a filter element of said self-cleaning air filter; and
- remove debris from the filter element of said self-cleaning air filter when the degree of clogging of the filter element exceeds a clogging threshold value.

**7.** The AFC system according to claim **6**, wherein the degree of clogging of the filter element is determined based on a pressure difference, the pressure difference being a difference between a pressure values measured upstream of said self-cleaning filter and a pressure value measured downstream of said self-cleaning air filter.

**8.** A wind turbine comprising:

- a rotor blade;
- at least one manifold extending at least partially through said rotor blade;
- an air intake duct configured to draw ambient air into said wind turbine;
- a gas supply coupled in flow communication with said at least one manifold and configured to supply gas to said at least one manifold; and
- a self-cleaning air filter coupled in flow communication with said air intake duct and said gas supply, said self-cleaning air filter configured to filter the ambient air channeled the filtered air to said gas supply.

**9.** The wind turbine according to claim **8**, wherein said self-cleaning air filter comprises a back-flushing air filter configured to be cleaned by a back-flushing air stream.

**10.** The wind turbine according to claim **9**, wherein said gas supply is configured to channel the back-flushing air stream to said self-cleaning air filter.

**11.** The wind turbine according to claim **8**, further comprising a pressurized air device coupled to flow communication said self-cleaning air filter to supply compressed air to said self-cleaning air filter, the compressed air used by said self-cleaning air filter to perform a self-cleaning function, wherein said self-cleaning air filter channels filtered air to said pressurized air device.

**12.** The wind turbine according to claim **8**, further comprising an exhaust valve being configured to channel debris from said self-cleaning air filter to outside said rotor blade.

**13.** The wind turbine according to claim **12**, wherein said exhaust valve is located on a suction side of said rotor blade adjacent at least one aperture defined through a surface of said rotor blade.

**14.** The wind turbine according to claim **8**, further comprising at least one aperture defined through a surface of said rotor blade, said at least one aperture in flow communication with said at least one manifold for ejecting air from said at least one manifold through said at least one aperture.

**15.** The wind turbine according to claim **8**, wherein said self-cleaning air filter is configured to:

- determine a degree of clogging of a filter element of said self-cleaning air filter; and
- remove debris from the filter element when the degree of clogging of the filter element exceeds a clogging threshold value.

**16.** A method for operating a wind turbine including an active flow control (AFC) system having a self-cleaning air filter, said method comprising:

drawing ambient air into the self-cleaning air filter such that debris is collected within the self-cleaning air filter; channeling a cleaning air stream into the self-cleaning air filter to dislodge the debris collected within the self-cleaning air filter; and channeling the dislodged debris from the self-cleaning air filter and away from the wind turbine.

**17.** The method in accordance with claim **16**, further comprising:

filtering the ambient air using the self-cleaning filter; and channeling the filtered air to the AFC system from the self-cleaning air filter.

**18.** The method in accordance with claim **17**, wherein said filtering the ambient air is performed at a first portion of a filter element of the self-cleaning air filter and said channeling a cleaning air stream into the self-cleaning air filter is performed at a second portion of the filter element.

**19.** The method in accordance with claim **17**, wherein said filtering the ambient air and said channeling a cleaning air stream into the self-cleaning air filter are performed continuously.

**20.** The method in accordance with claim **16**, wherein the AFC system include a gas supply, channeling a cleaning air stream into the self-cleaning air filter further comprising channeling the cleaning air stream from the gas supply into the self-cleaning air filter.

\* \* \* \* \*