



US 20100133110A1

(19) **United States**

(12) **Patent Application Publication**
Nocera et al.

(10) **Pub. No.: US 2010/0133110 A1**
(43) **Pub. Date: Jun. 3, 2010**

(54) **CATALYTIC MATERIALS, PHOTOANODES, AND PHOTOELECTROCHEMICAL CELLS FOR WATER ELECTROLYSIS AND OTHER, ELECTROCHEMICAL TECHNIQUES**

(21) Appl. No.: **12/576,026**

(22) Filed: **Oct. 8, 2009**

Related U.S. Application Data

(75) Inventors: **Daniel G. Nocera**, Winchester, MA (US); **Matthew W. Kanan**, Palo Alto, CA (US); **Thomas A. Moore**, Scottsdale, AZ (US); **Yogesh Surendranath**, Cambridge, MA (US); **Steven Y. Reece**, Cambridge, MA (US); **Arthur J. Esswein**, Boston, MA (US)

(60) Provisional application No. 61/103,905, filed on Oct. 8, 2008, provisional application No. 61/187,995, filed on Jun. 17, 2009.

Publication Classification

(51) **Int. Cl.**
C25B 1/04 (2006.01)
C25B 11/04 (2006.01)
(52) **U.S. Cl.** **205/340; 502/101; 252/182.1**

Correspondence Address:
WOLF GREENFIELD & SACKS, P.C.
600 ATLANTIC AVENUE
BOSTON, MA 02210-2206 (US)

(57) **ABSTRACT**

(73) Assignees: **Massachusetts Institute of Technology**, Cambridge, MA (US); **Arizona Board of Regents**, Scottsdale, AZ (US); **Sun Catalytix Corporation**, Cambridge, MA (US)

Catalytic materials, photoanodes, and systems for electrolysis and/or formation of water are provided which can be used for energy storage, particularly in the area of solar energy conversion, and/or production of oxygen and/or hydrogen. Compositions and methods for forming photoanodes and other devices are also provided.

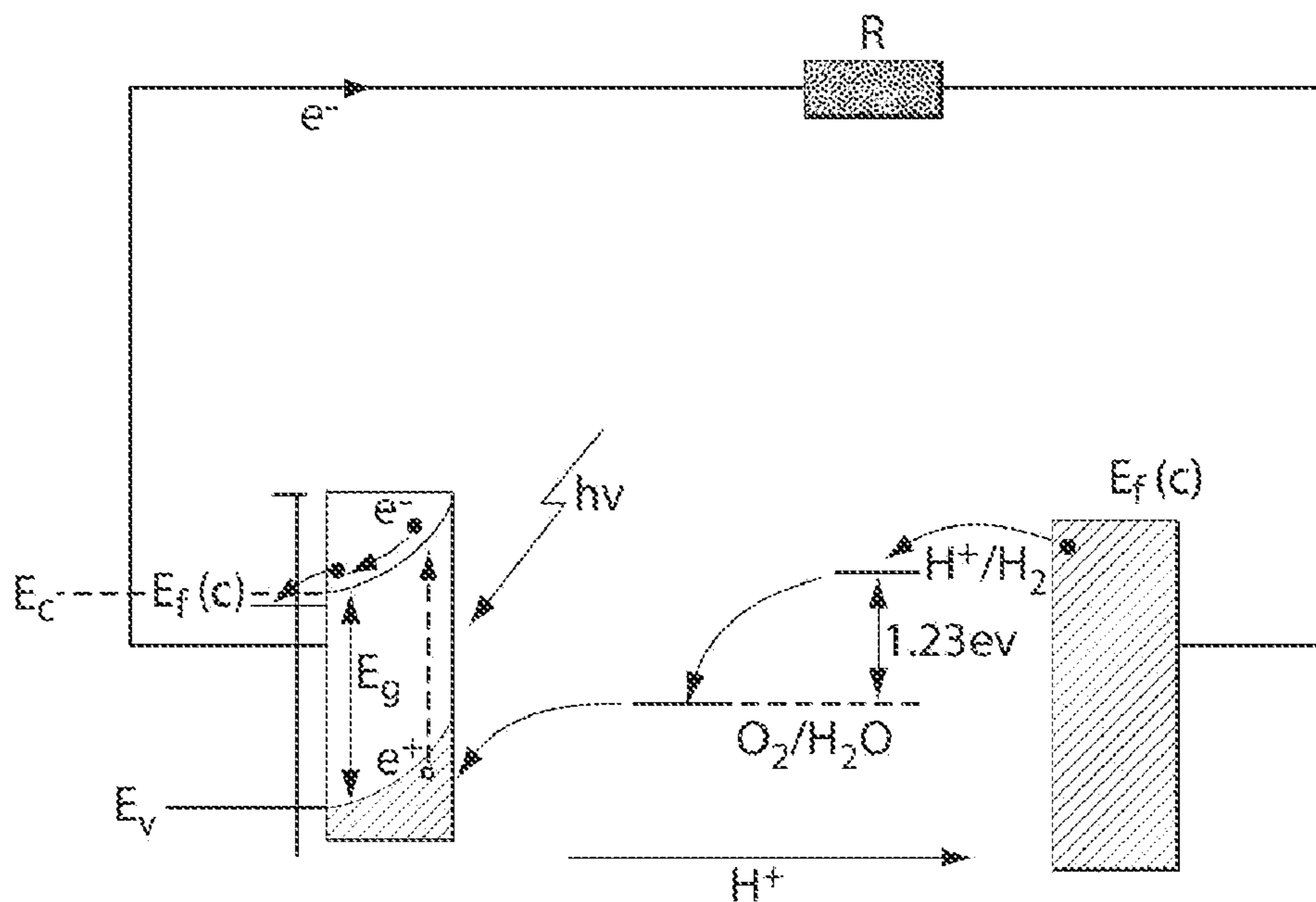

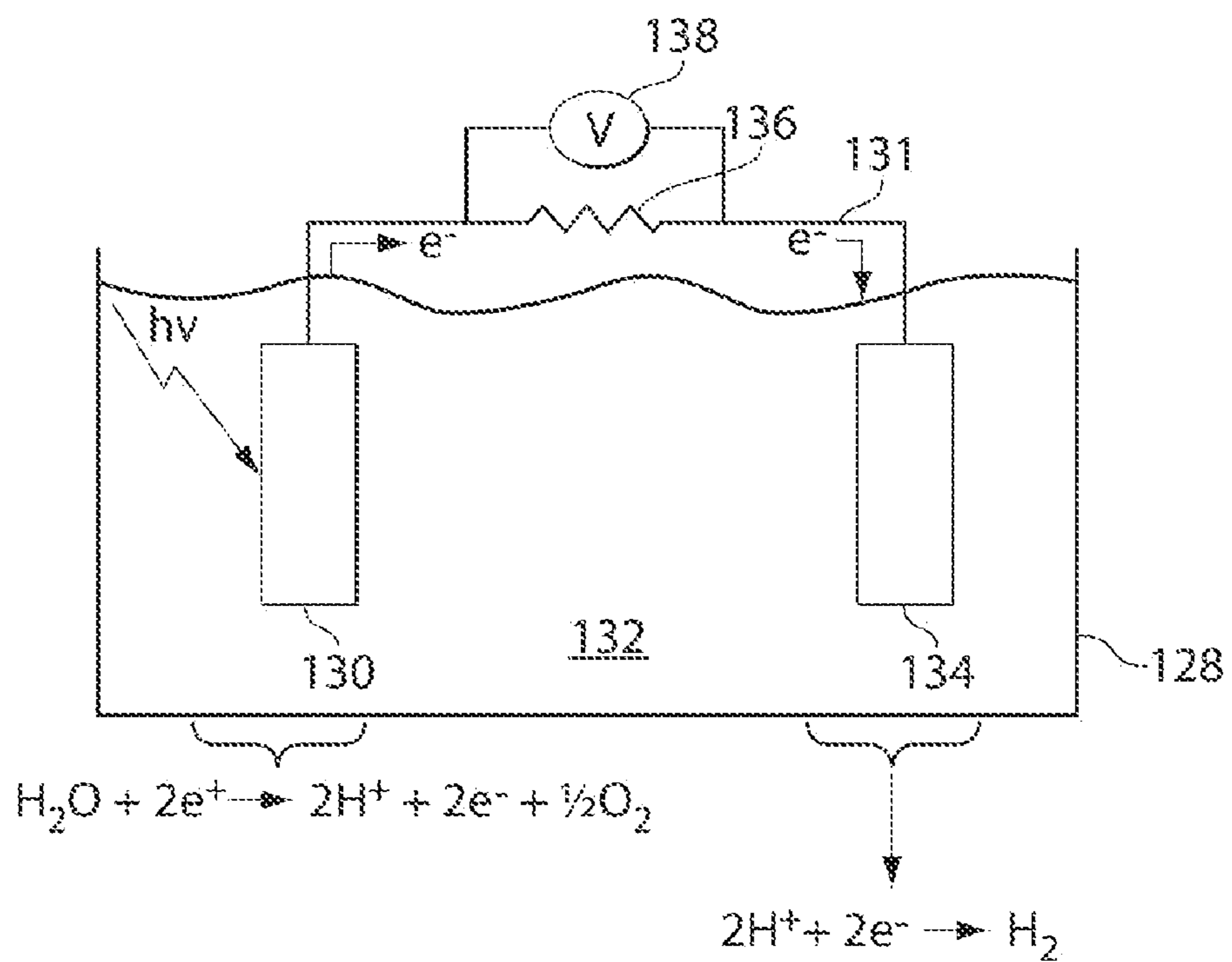

FIG. 1

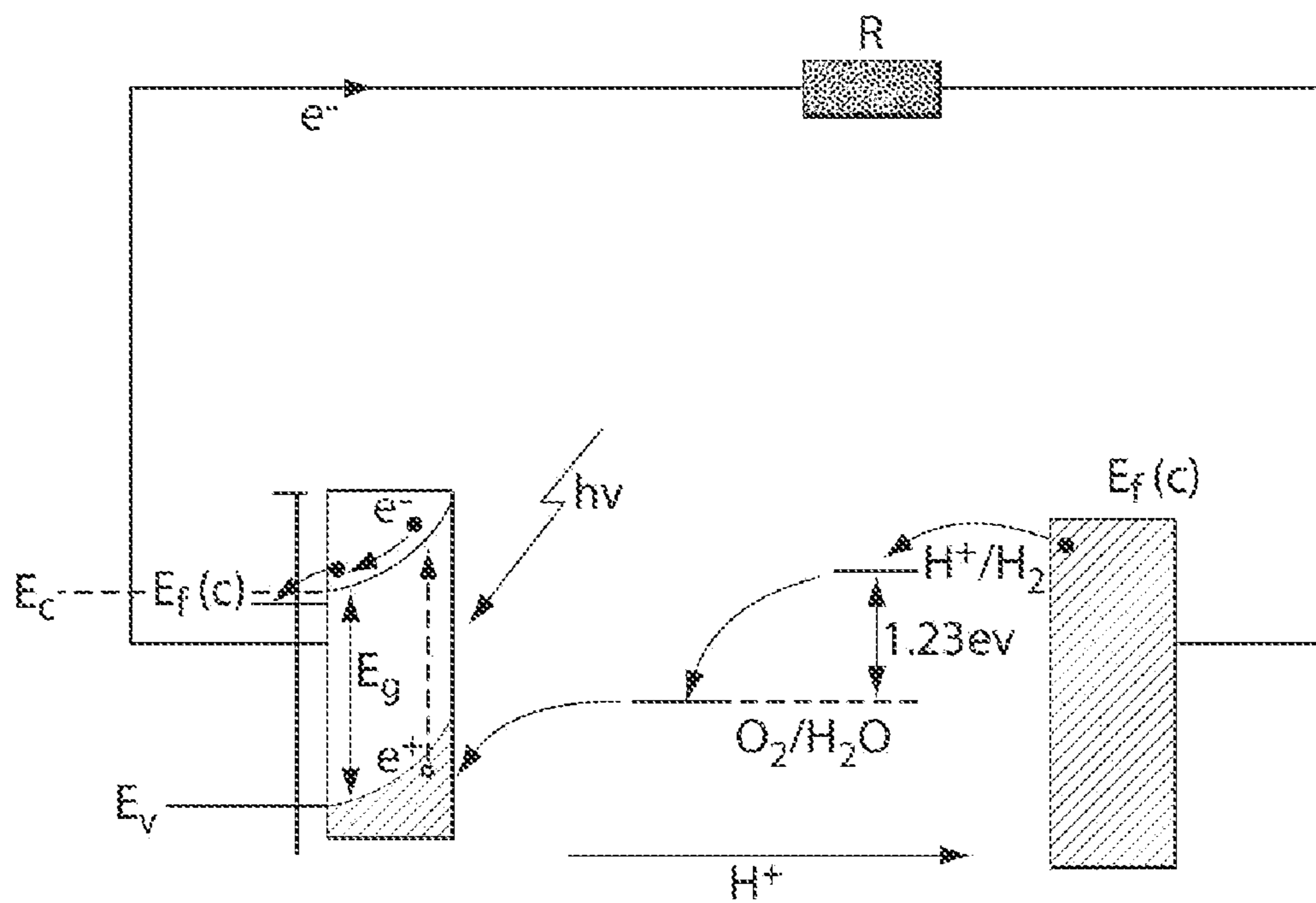

FIG. 2

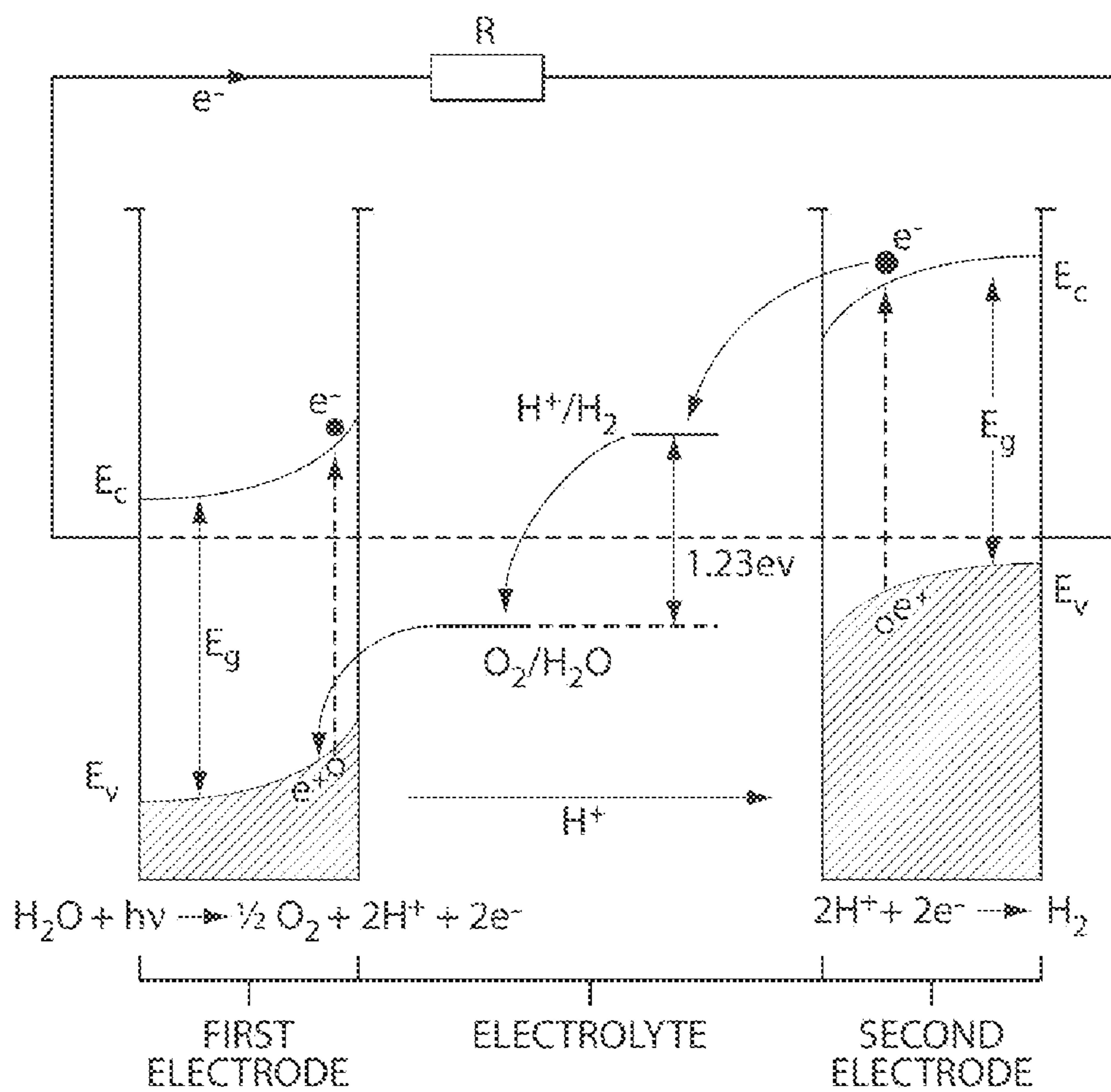

FIG. 3

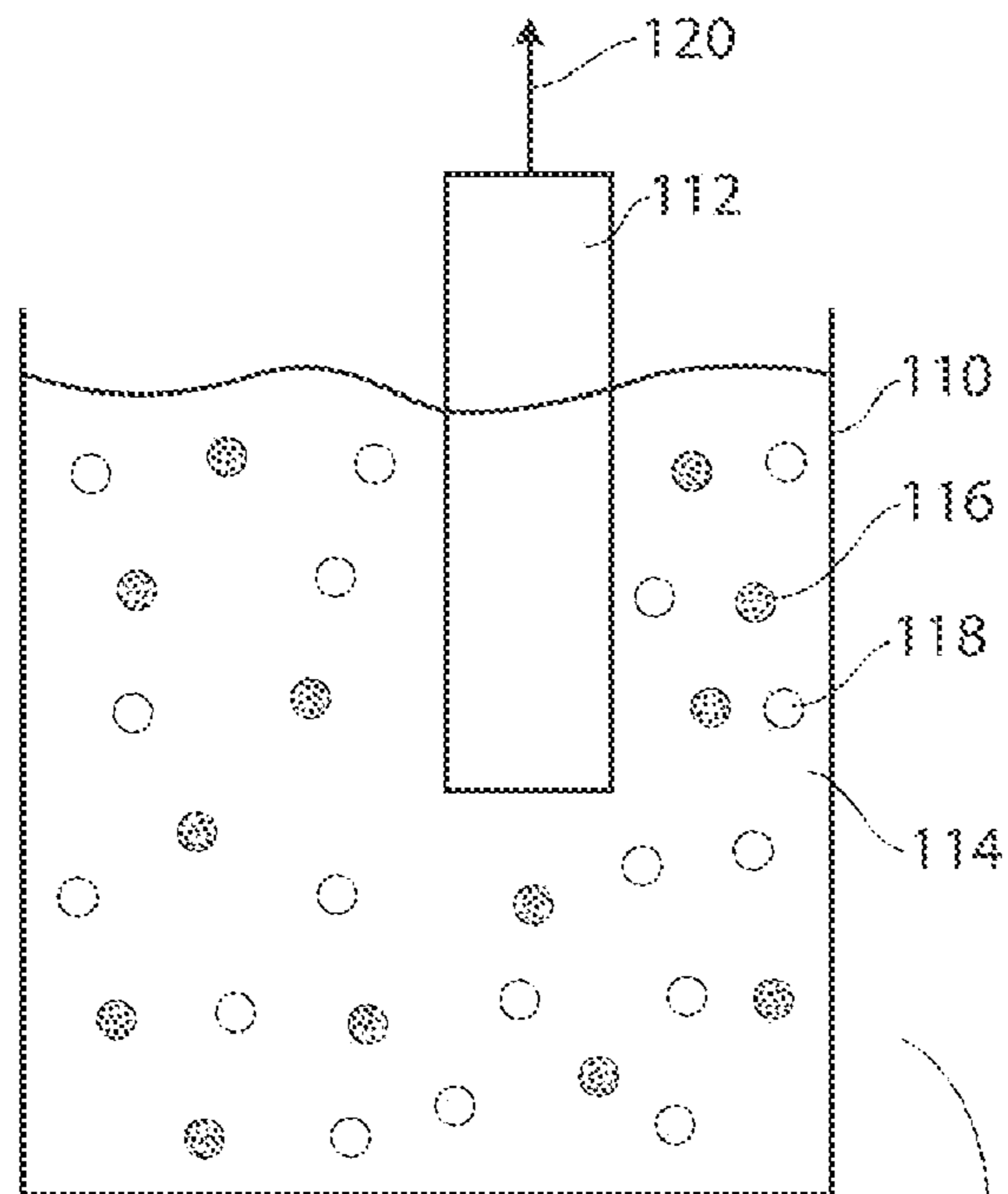

FIG. 4A

To FIG. 4B

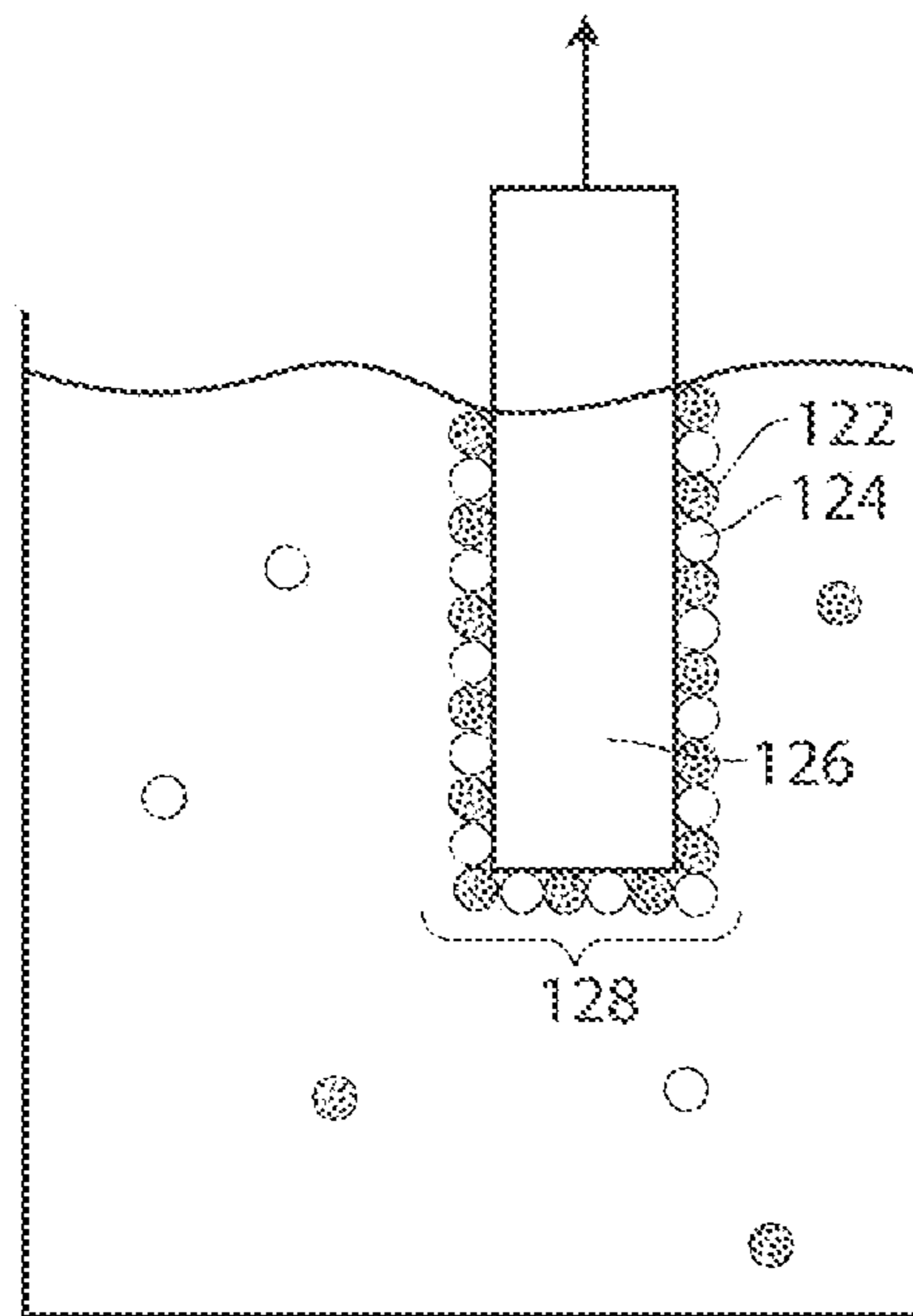

FIG. 4B

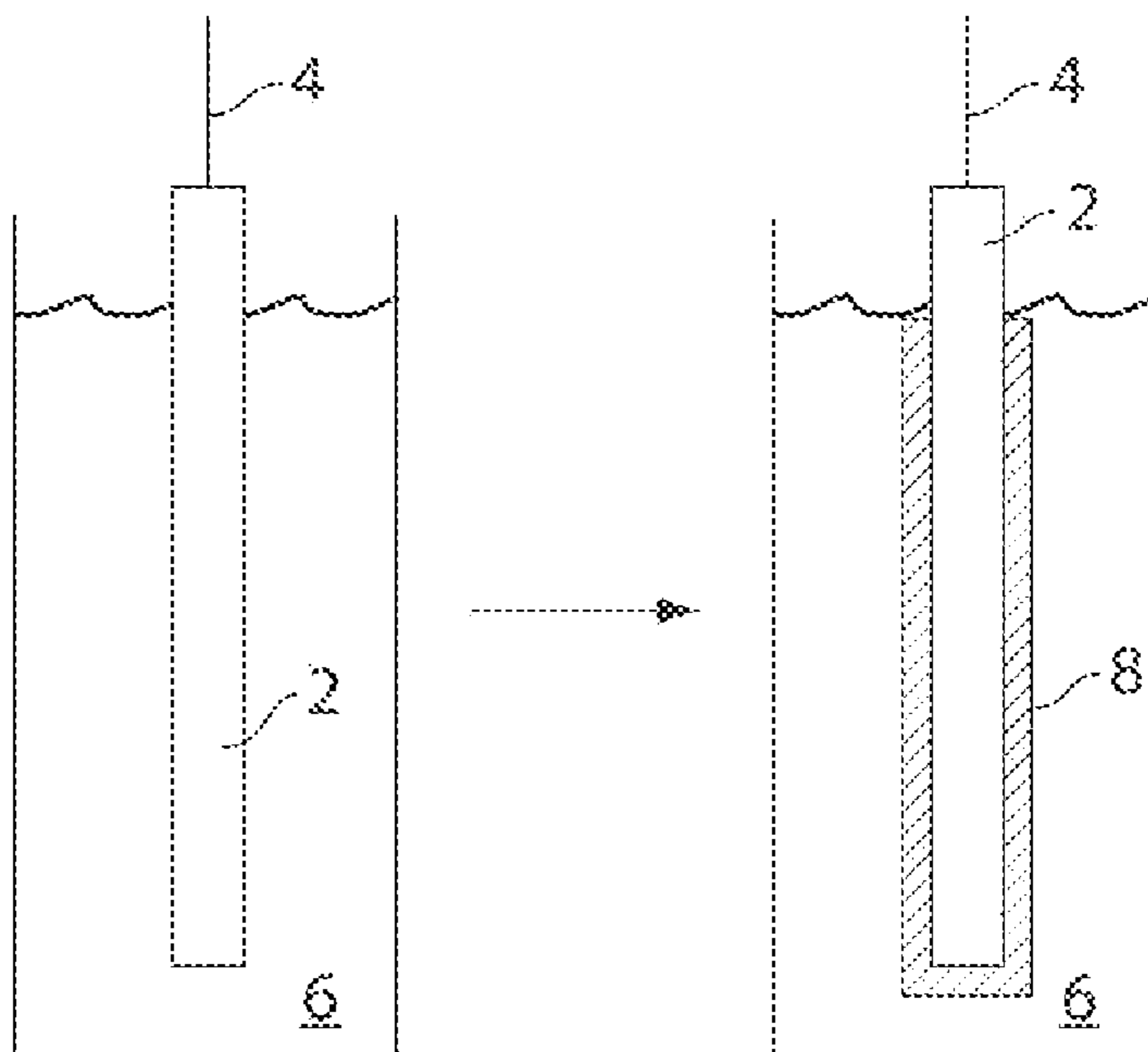

FIG. 5A

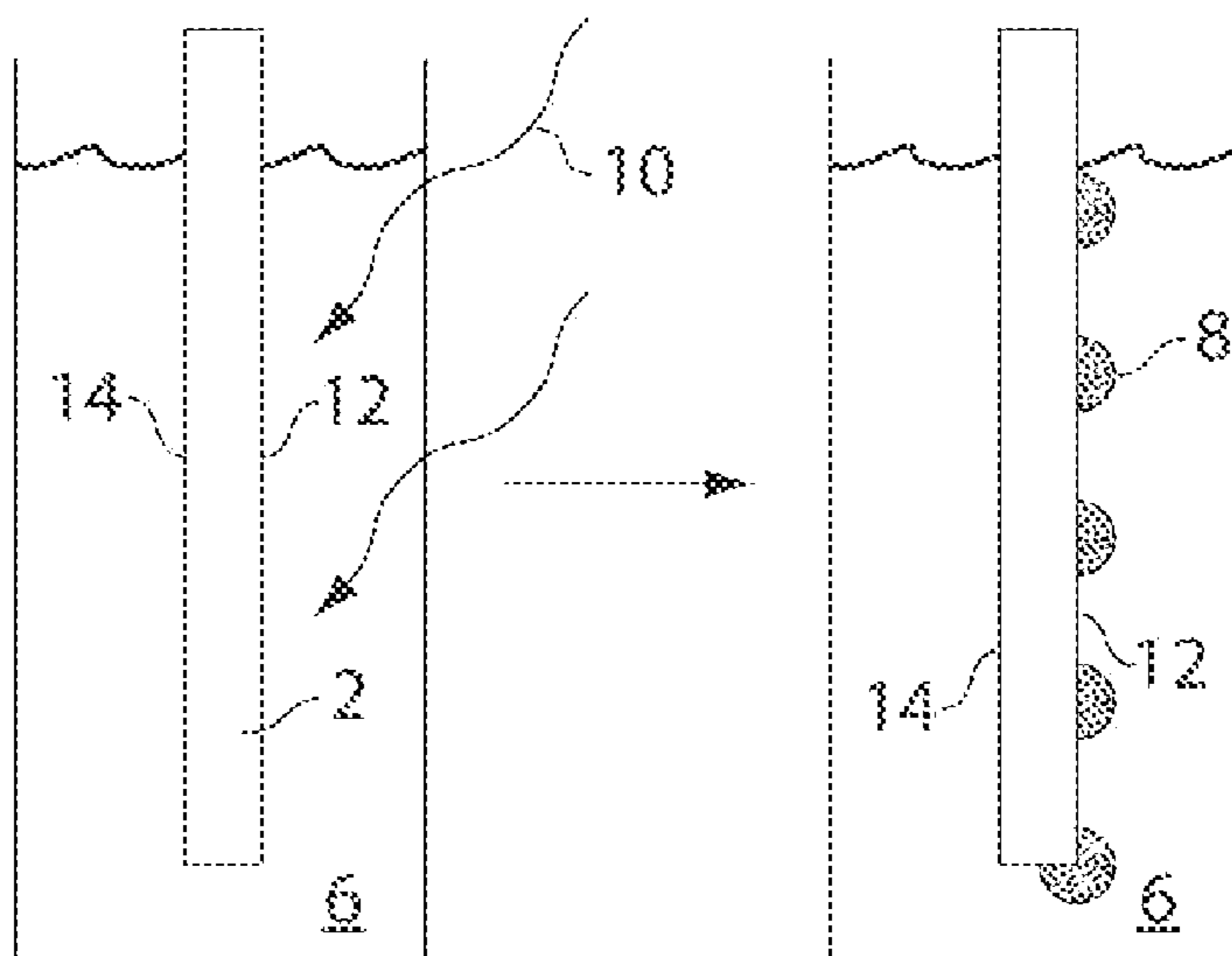

FIG. 5B

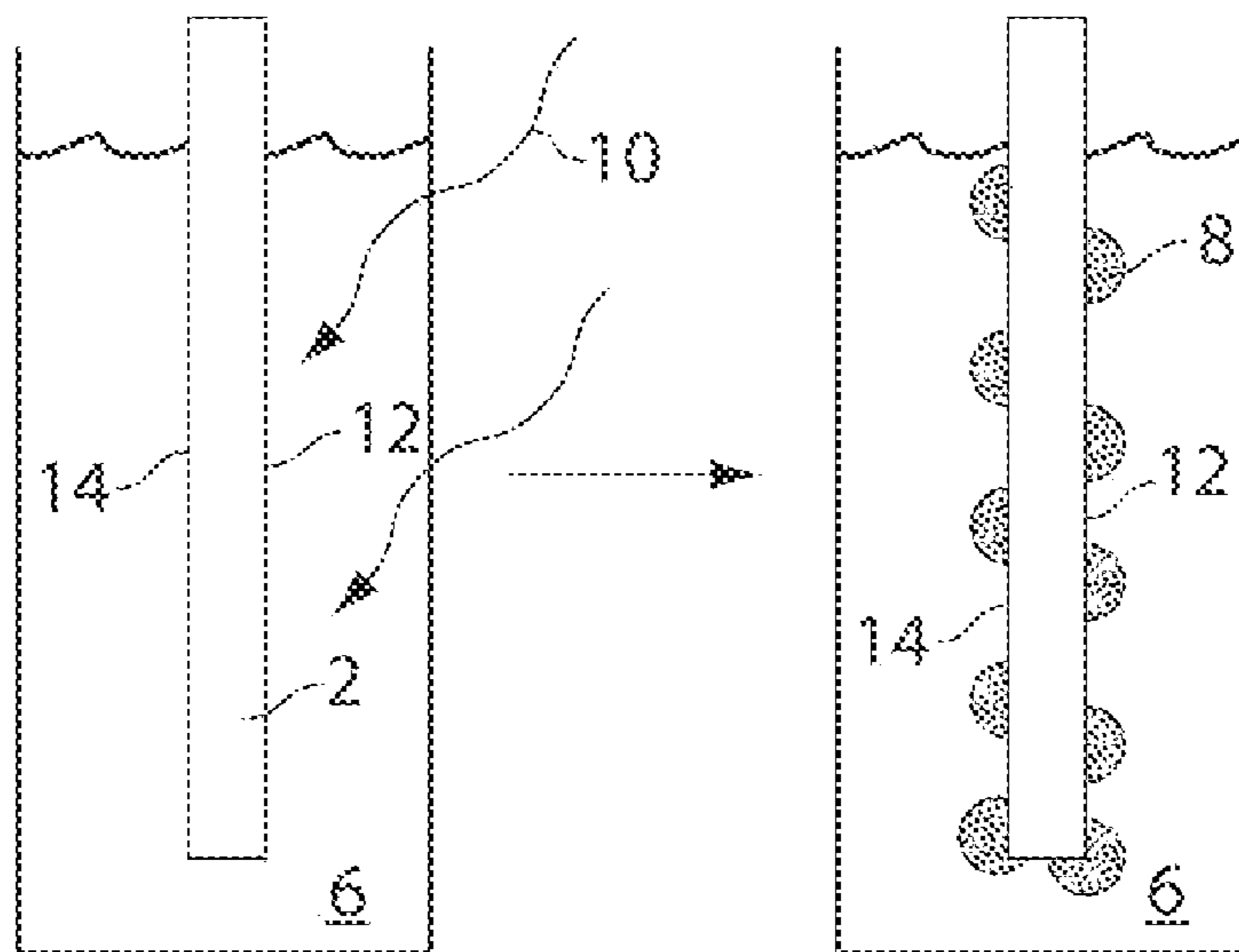

FIG. 5C

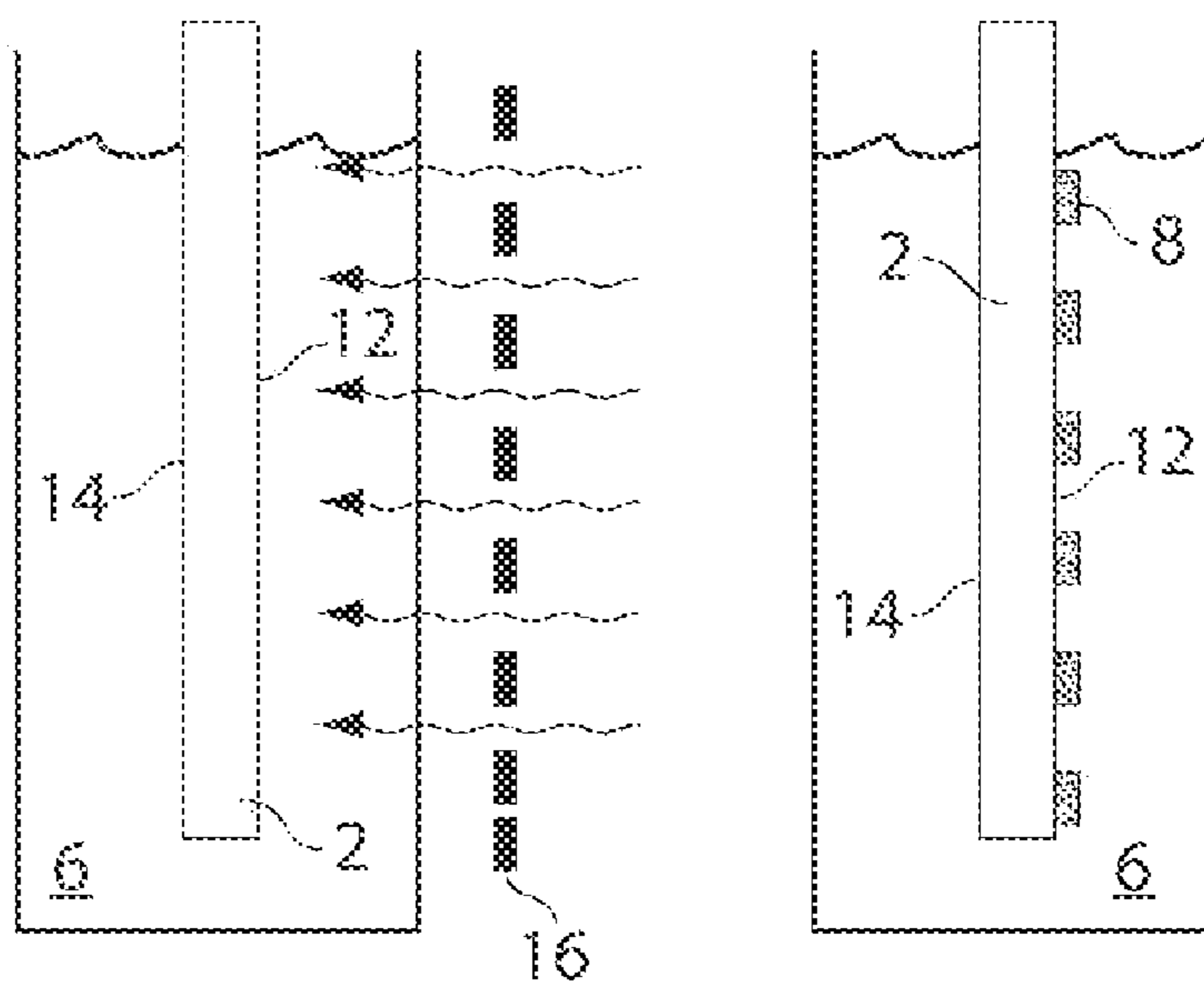

FIG. 5D

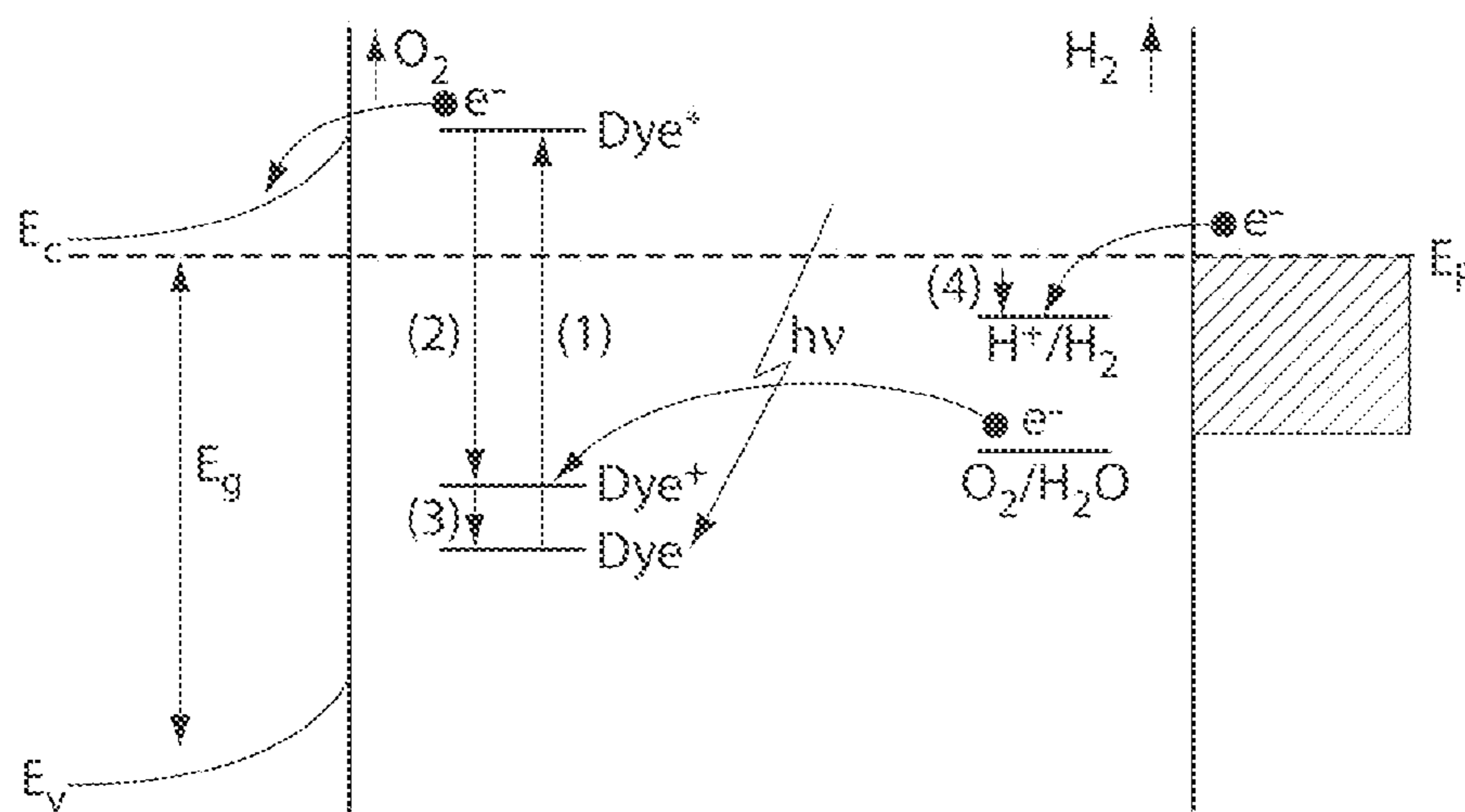

FIG. 6

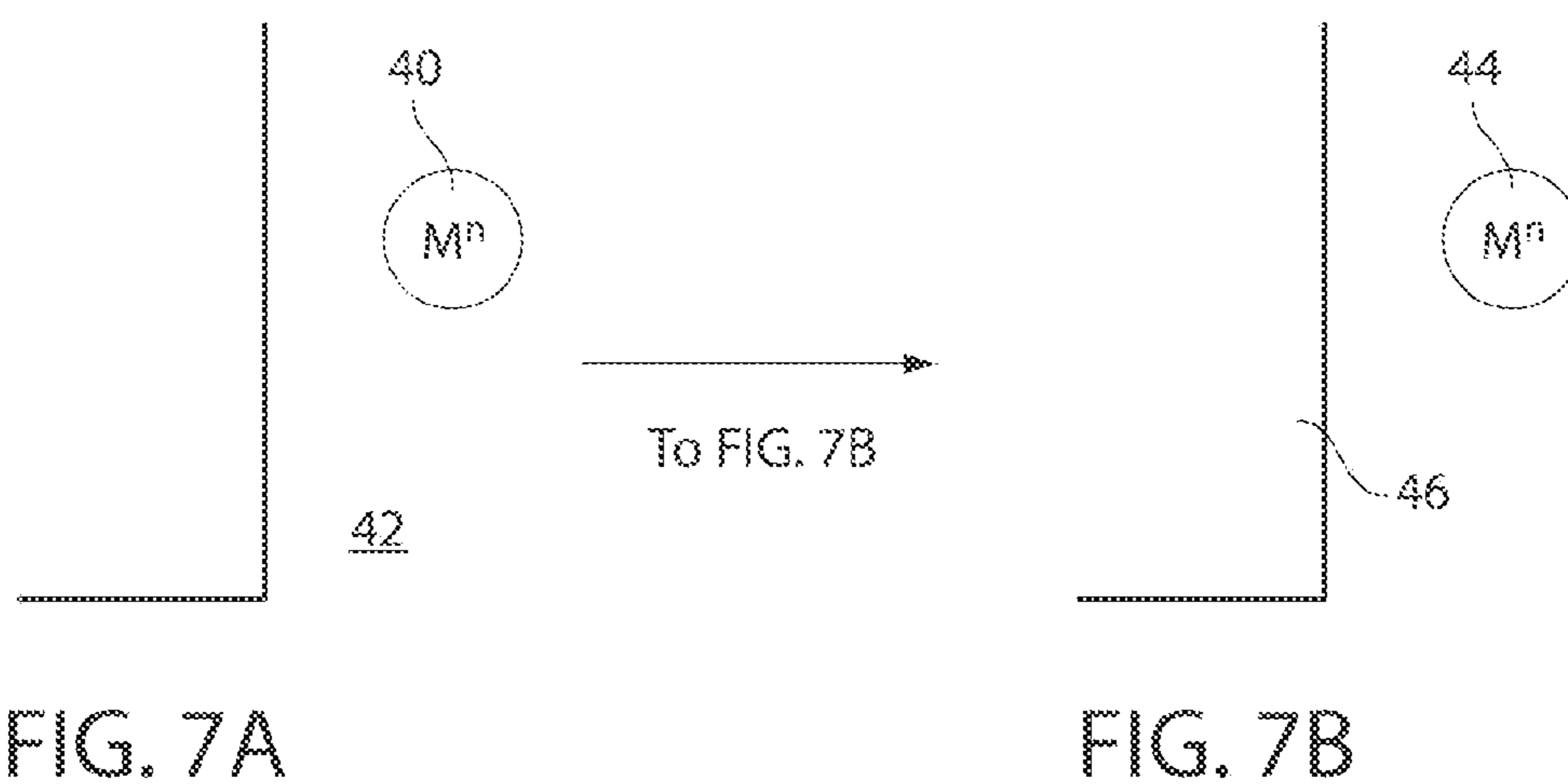
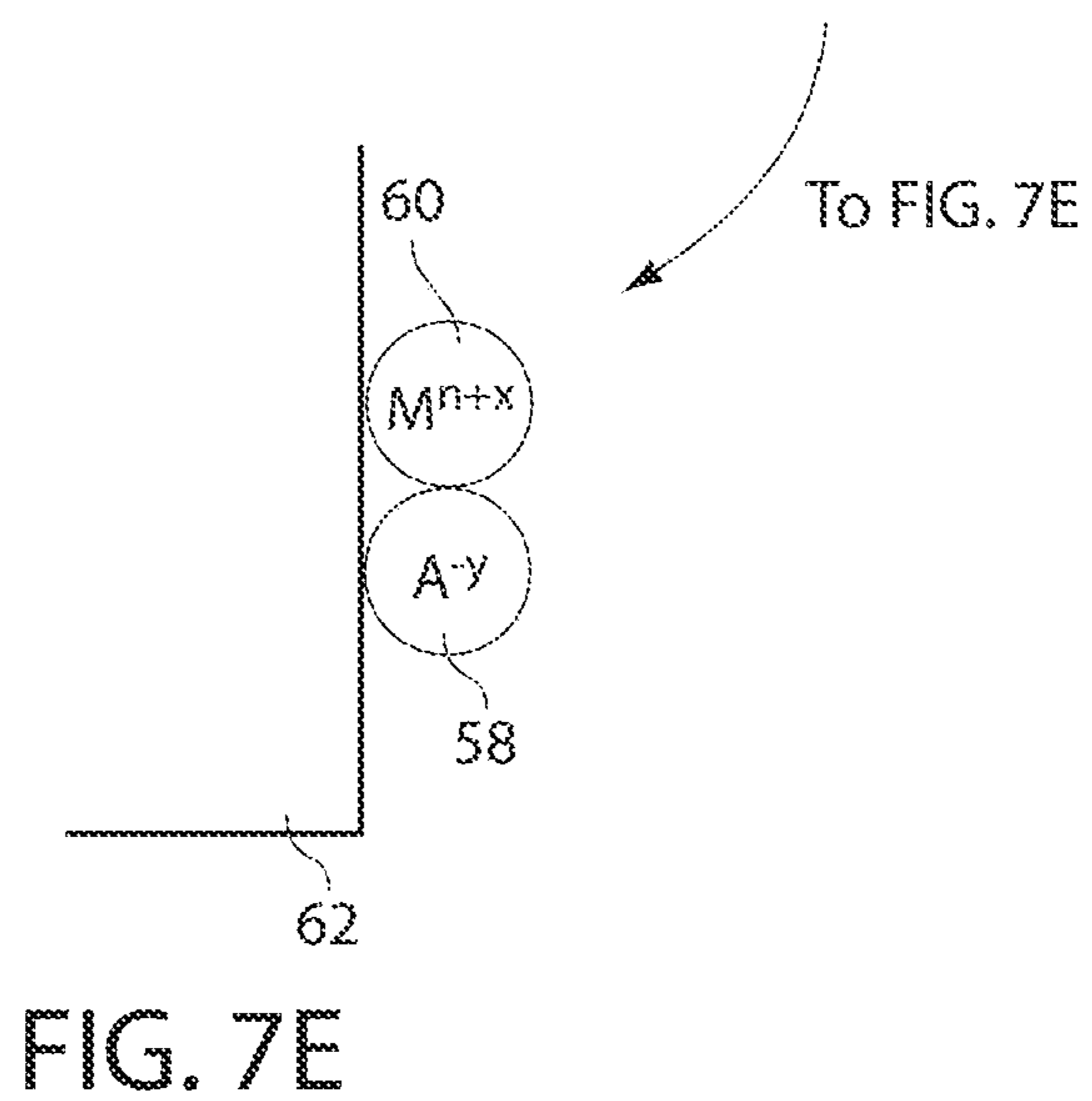
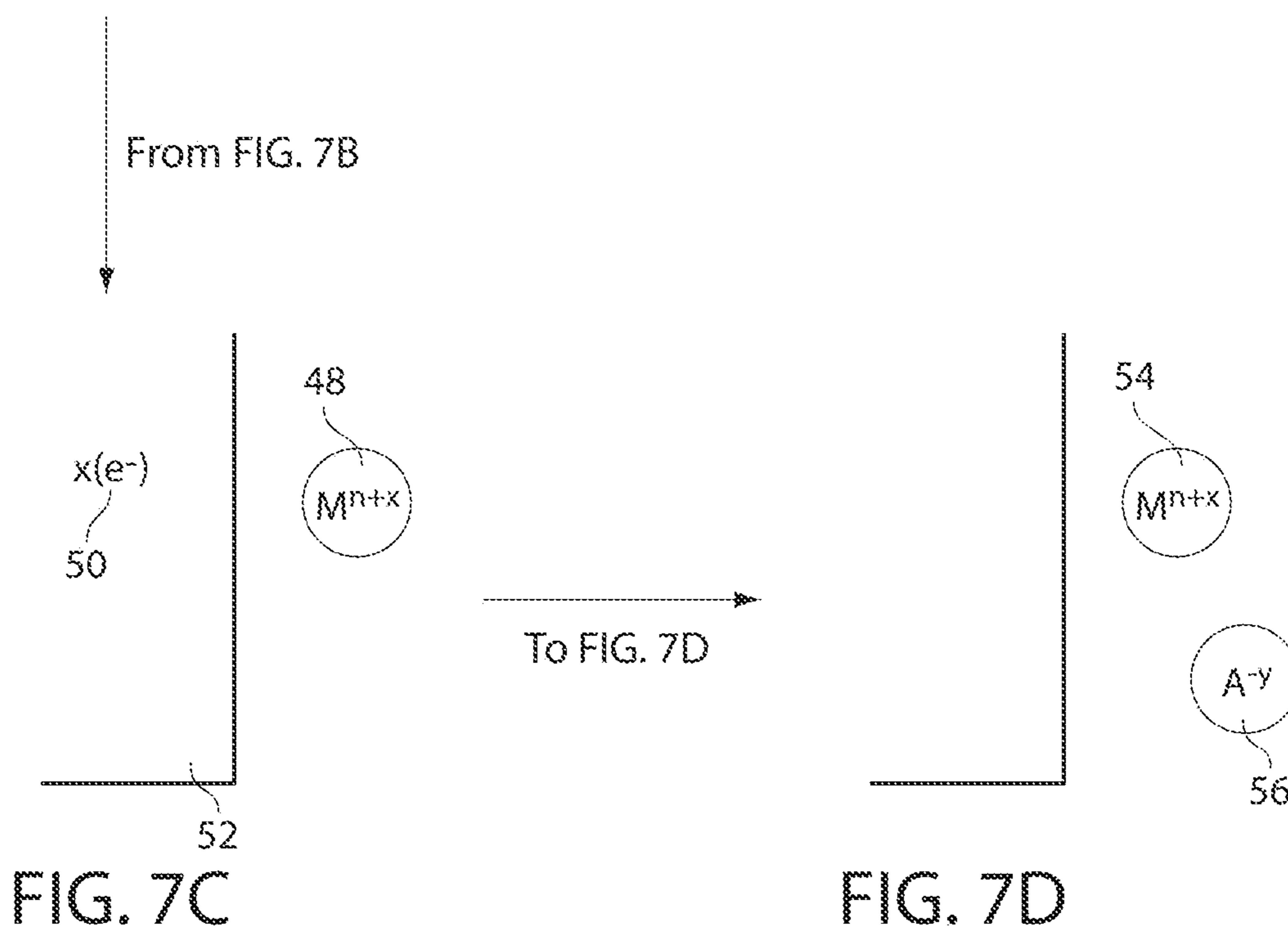

FIG. 7A

FIG. 7B



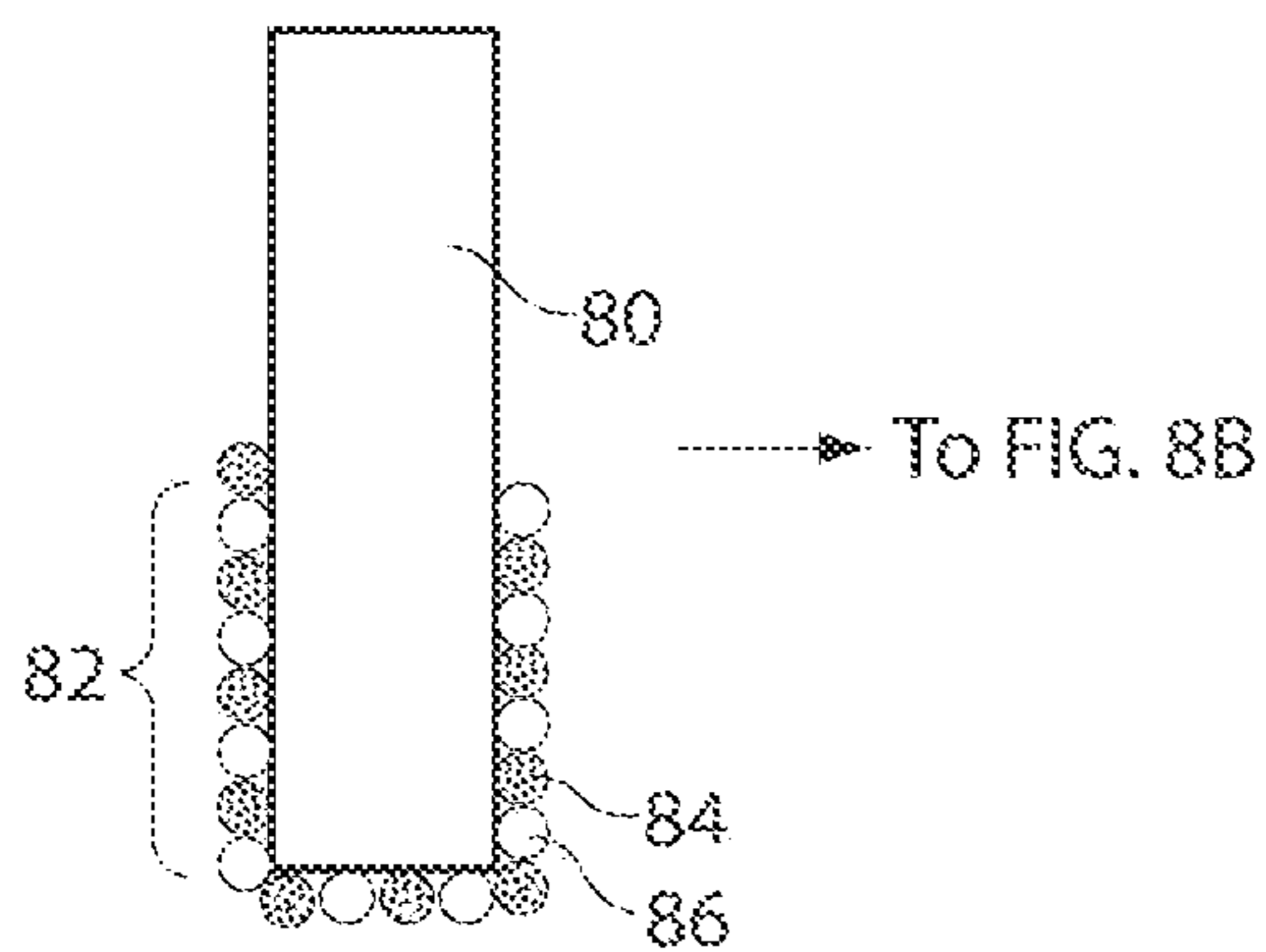

FIG. 8A

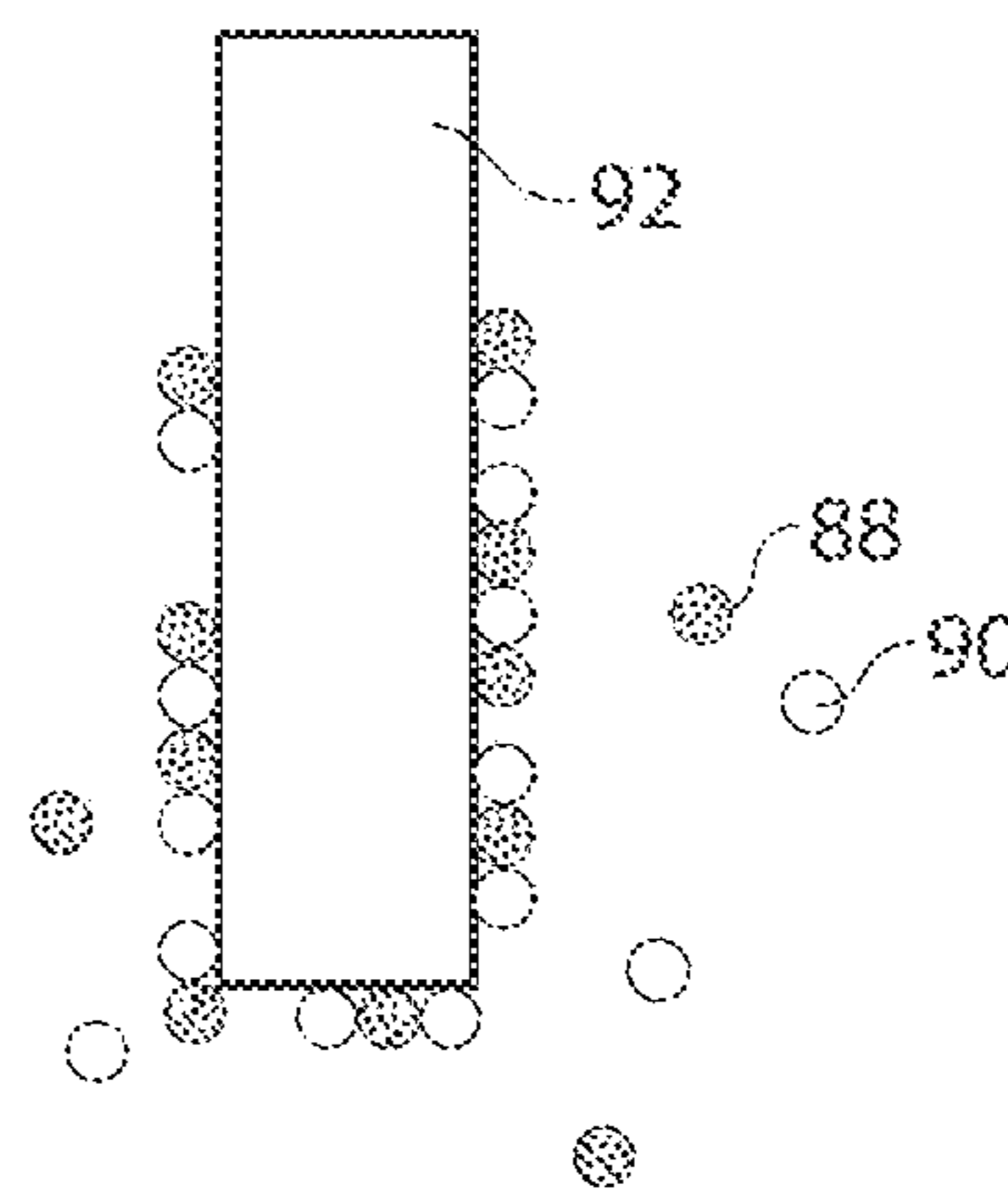

FIG. 8B

From FIG. 8B

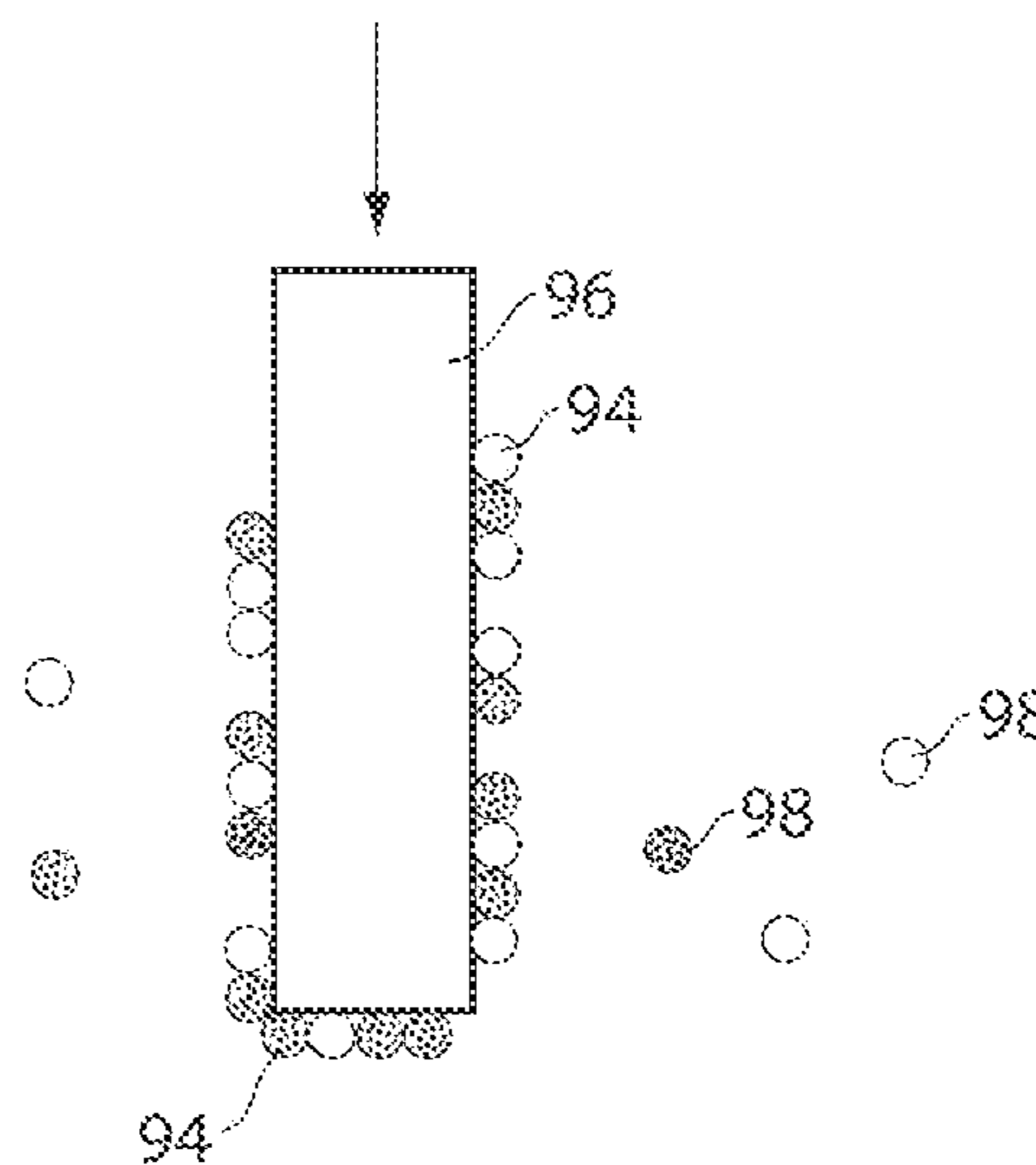
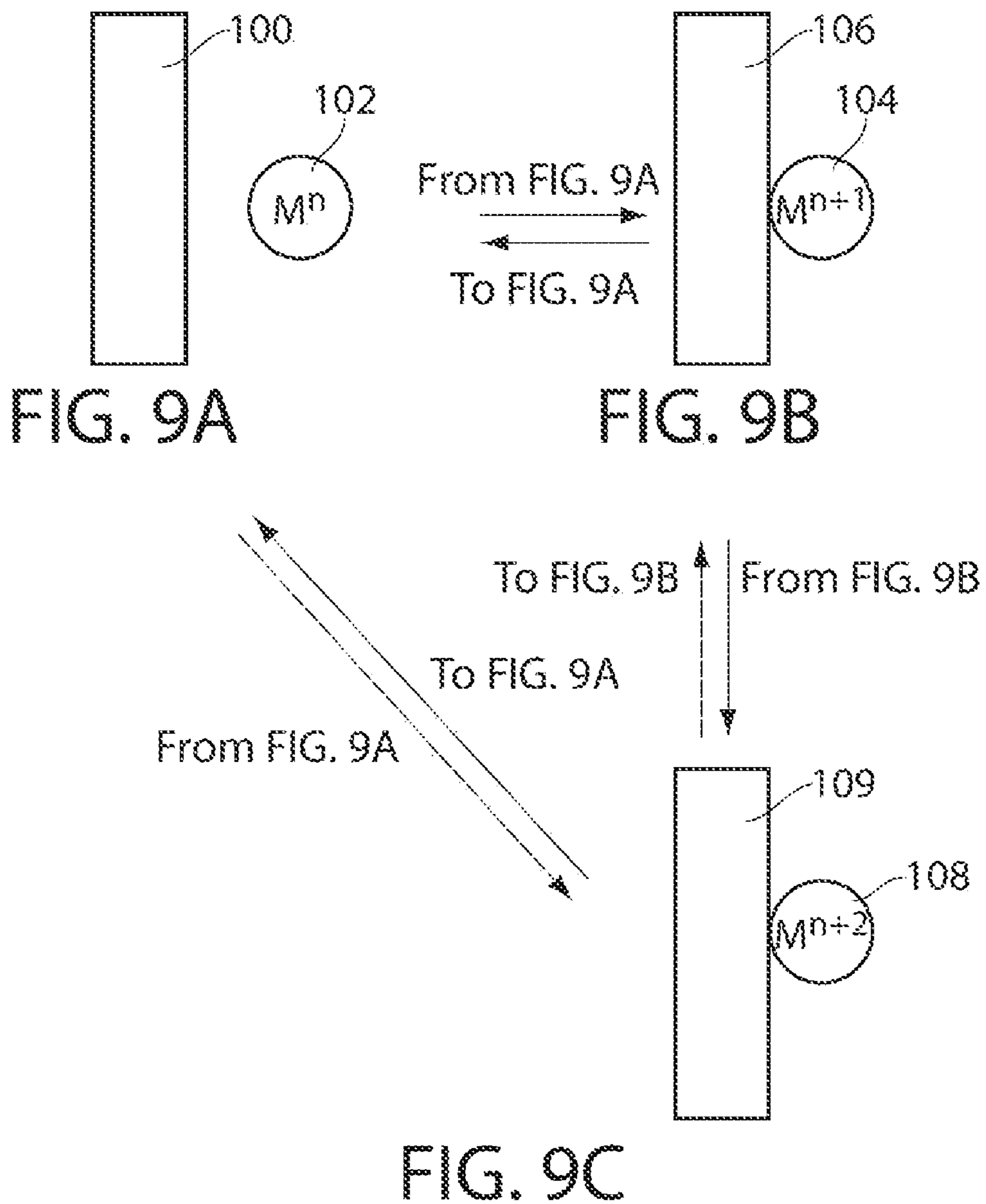

FIG. 8C



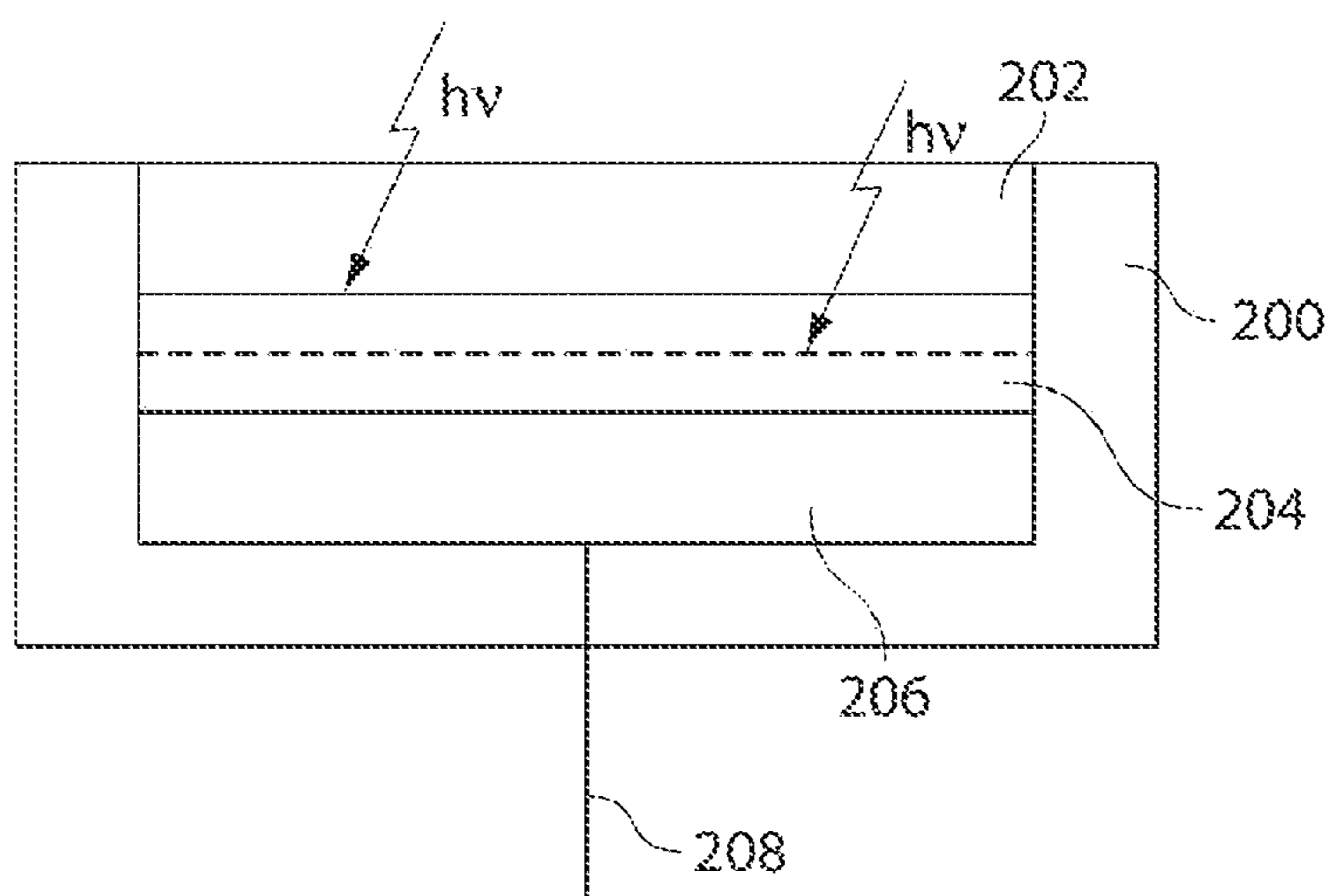

FIG. 10

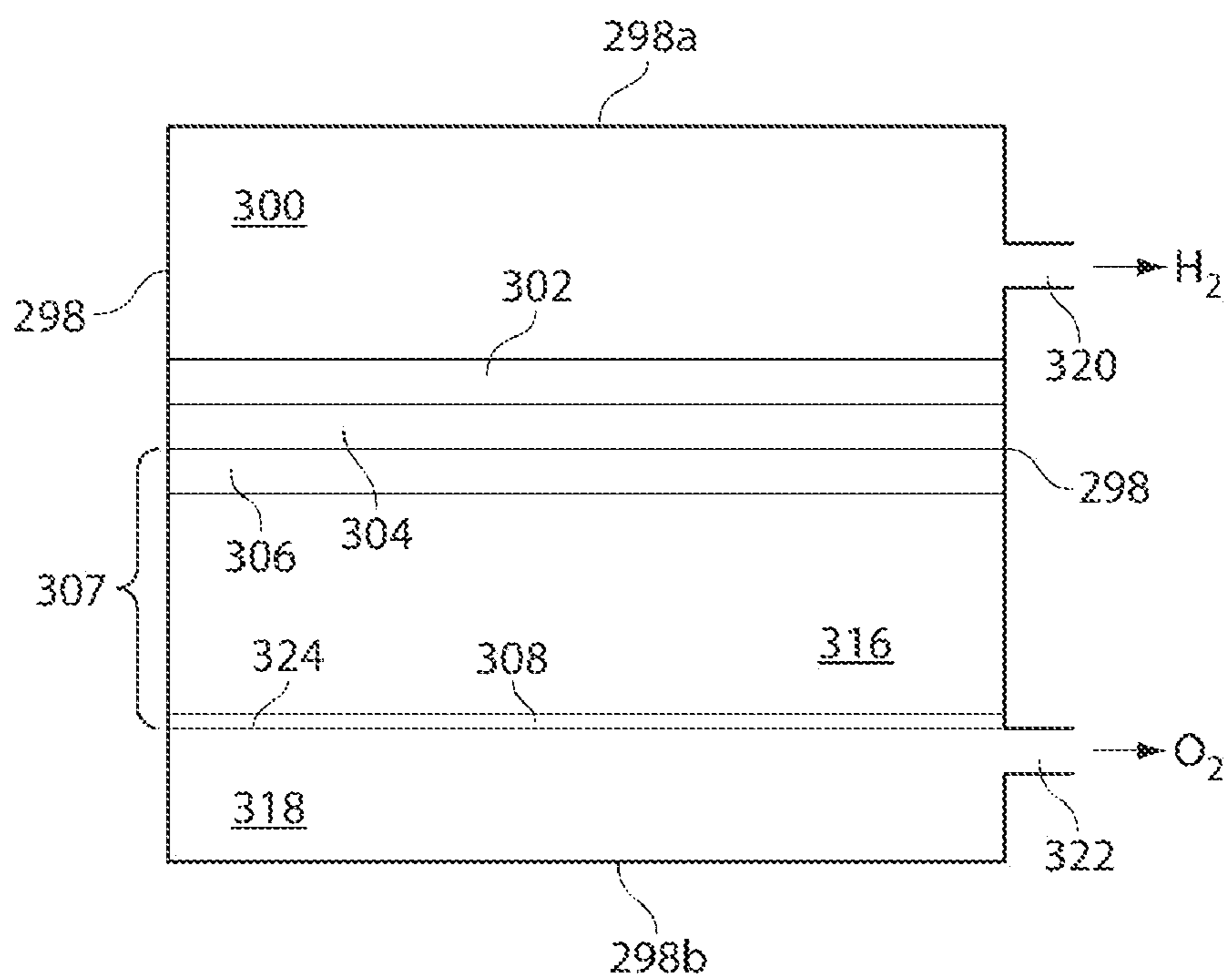

FIG. 11

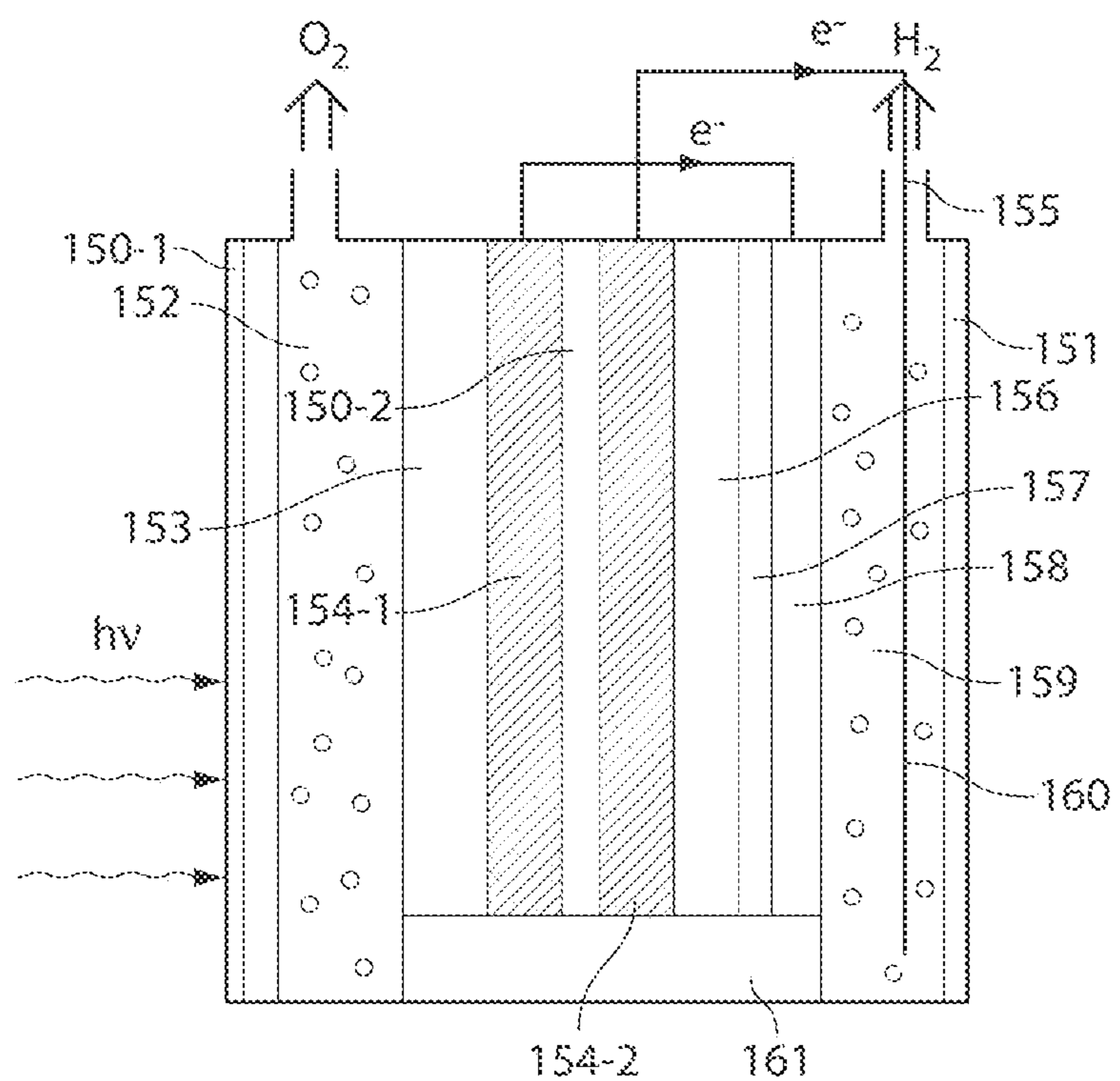

FIG. 12

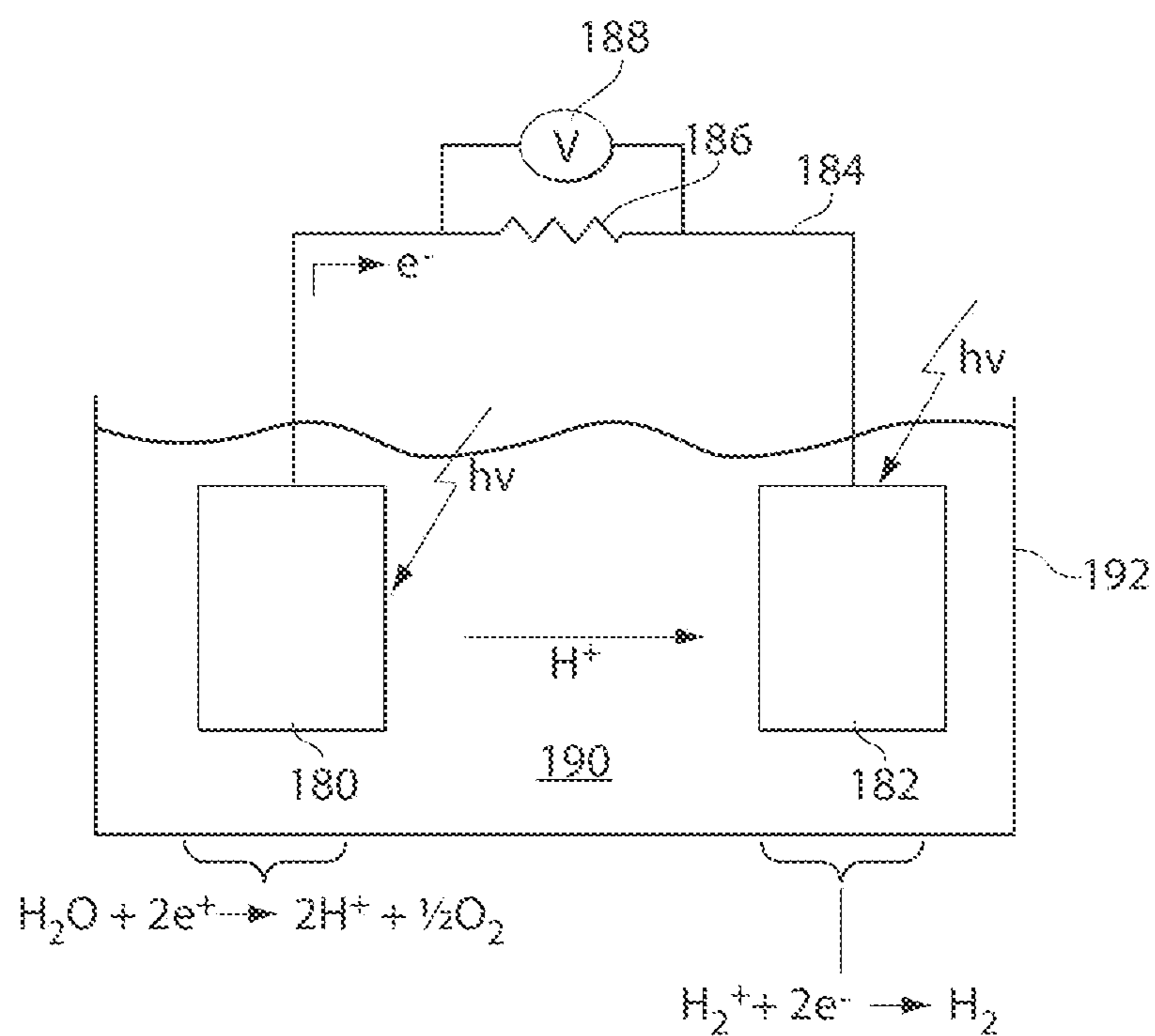

FIG. 13

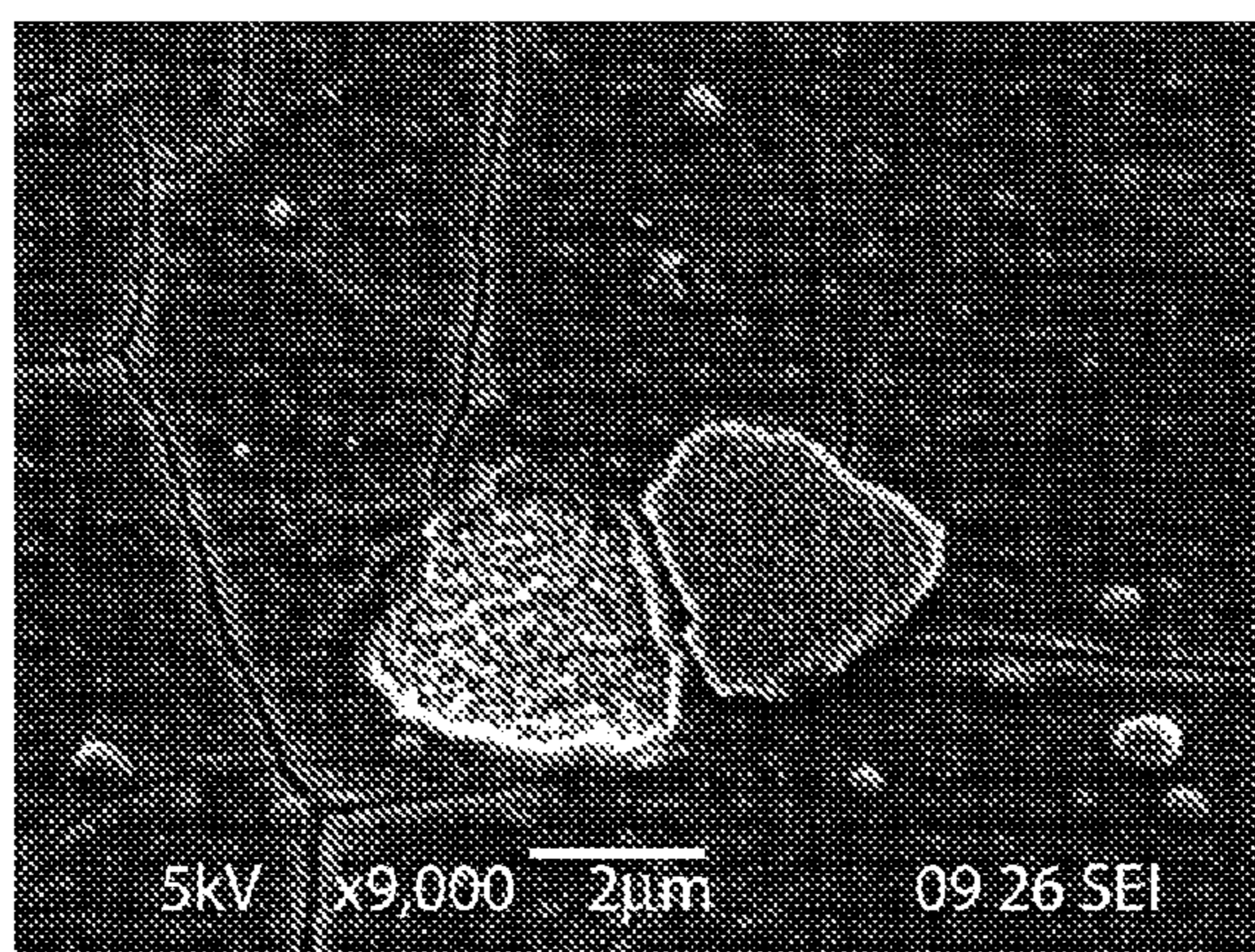

FIG. 14

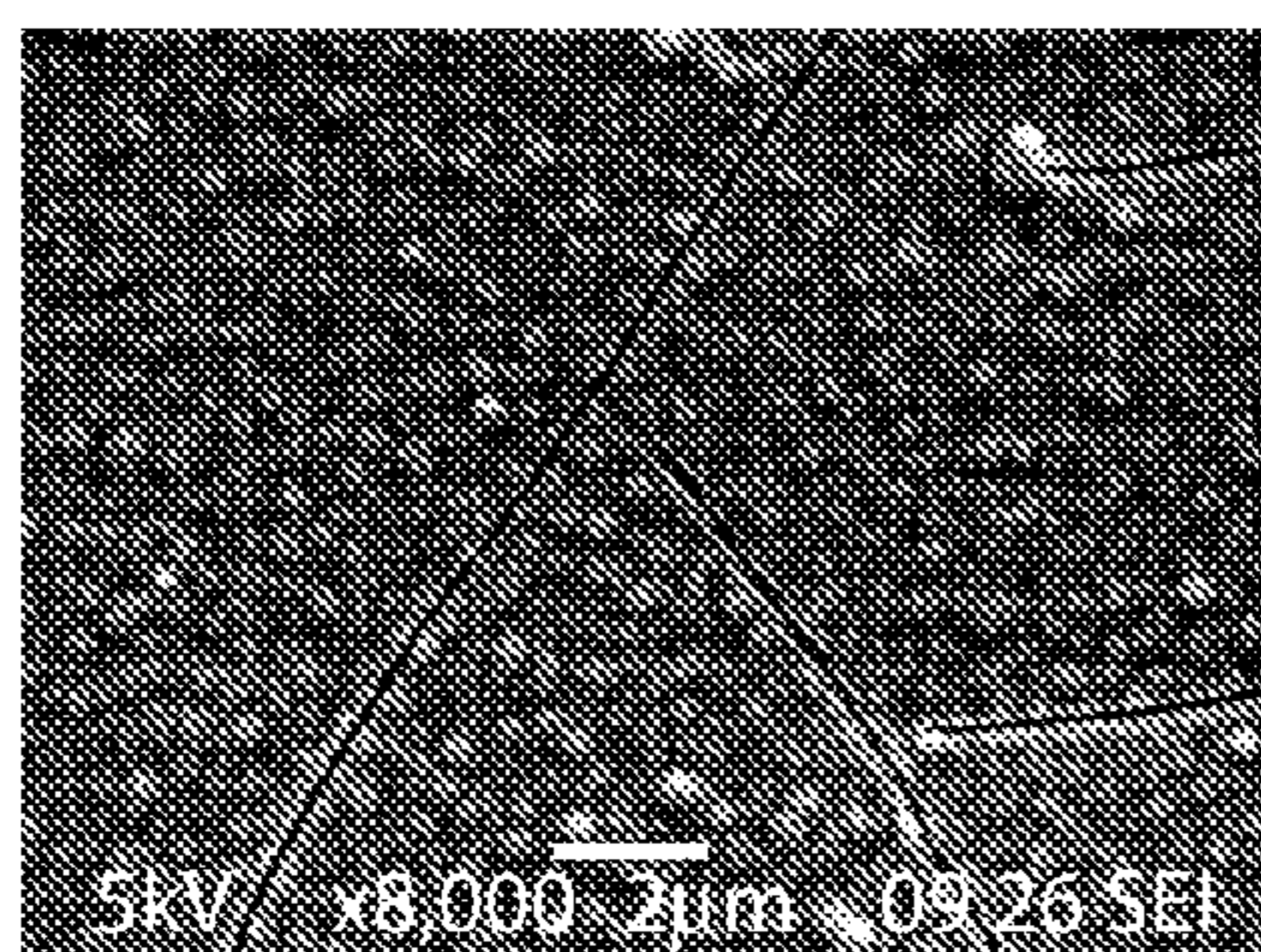

FIG. 15A

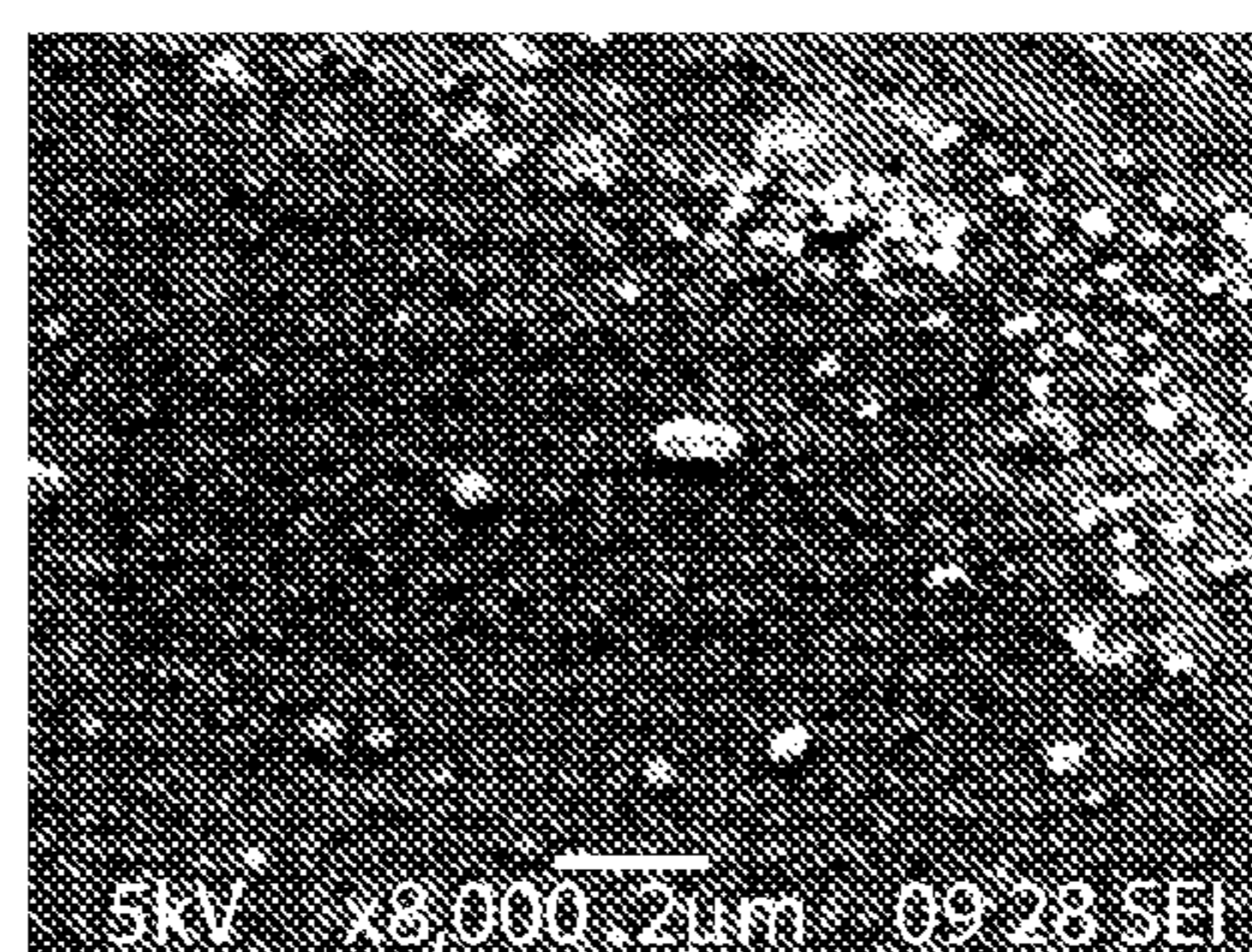

FIG. 15B

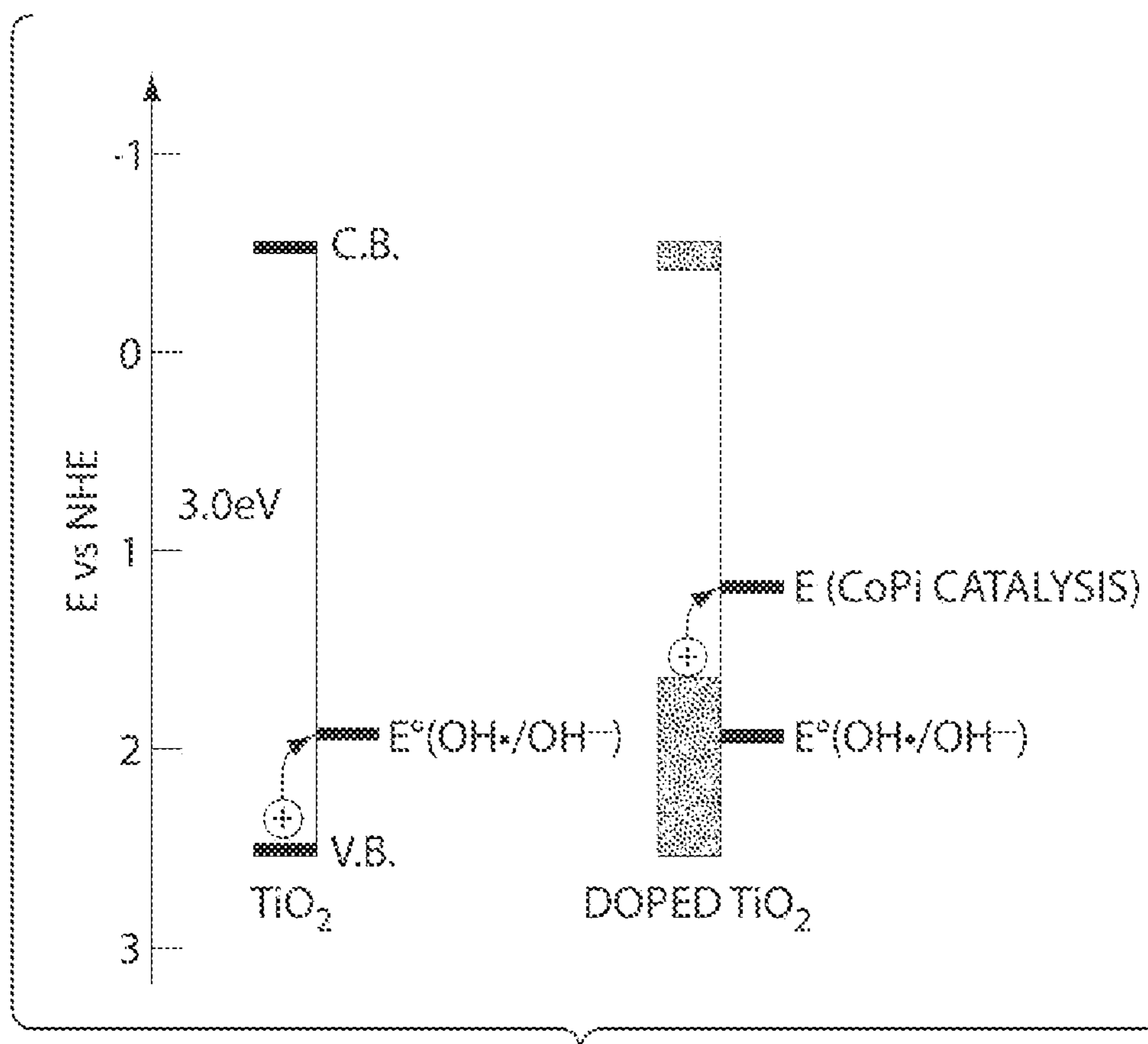

FIG. 16

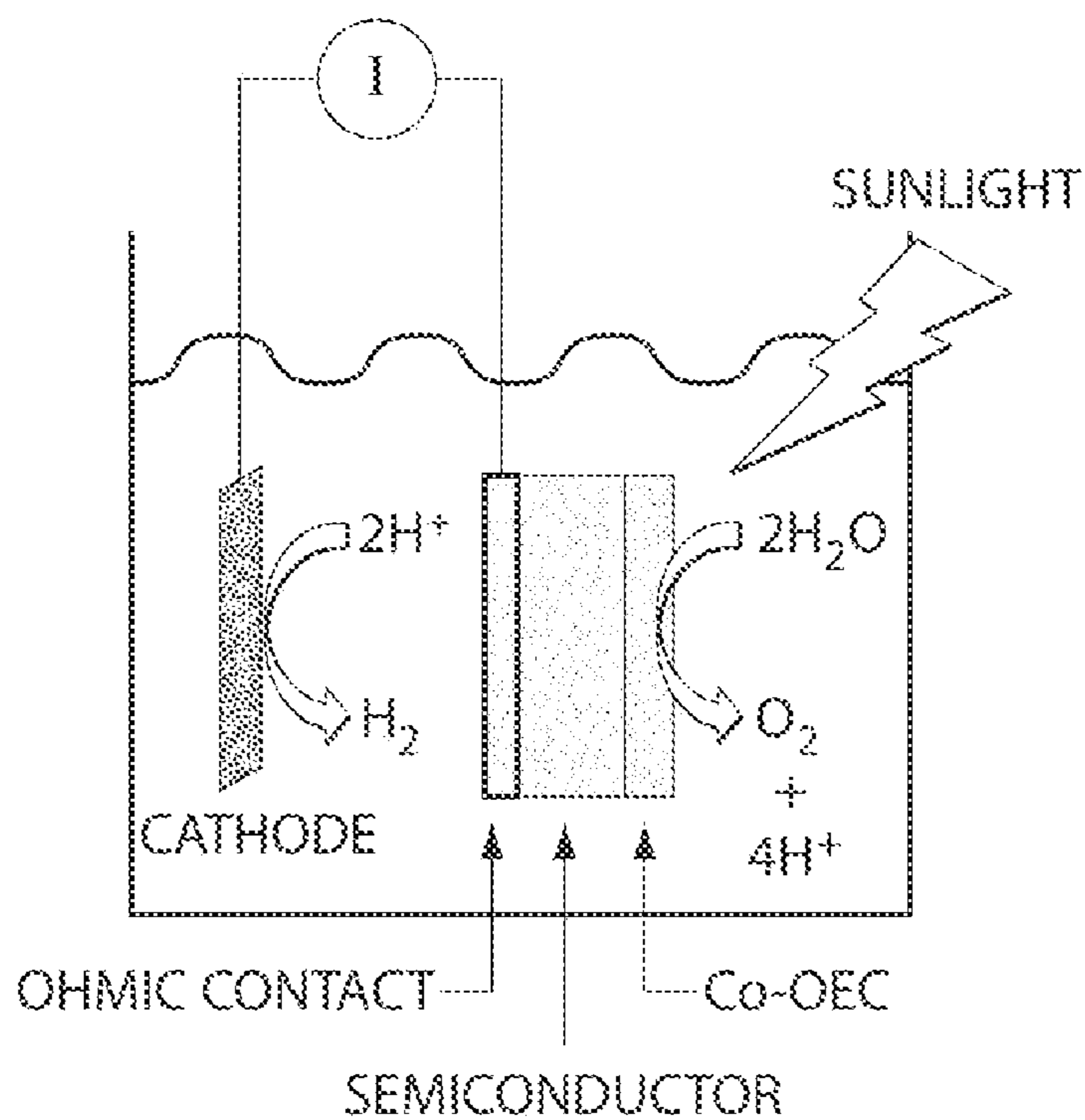

FIG. 17A

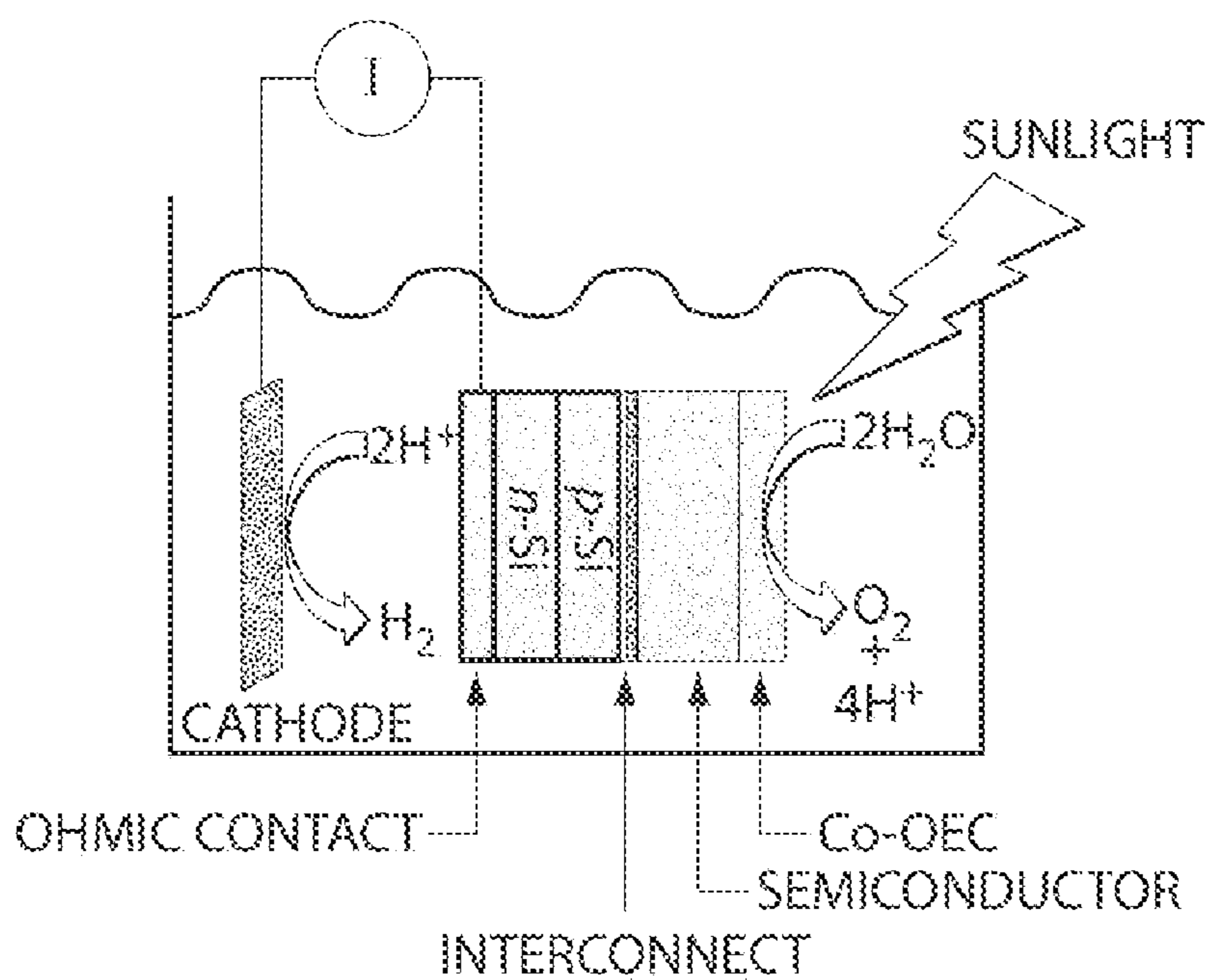

FIG. 17B

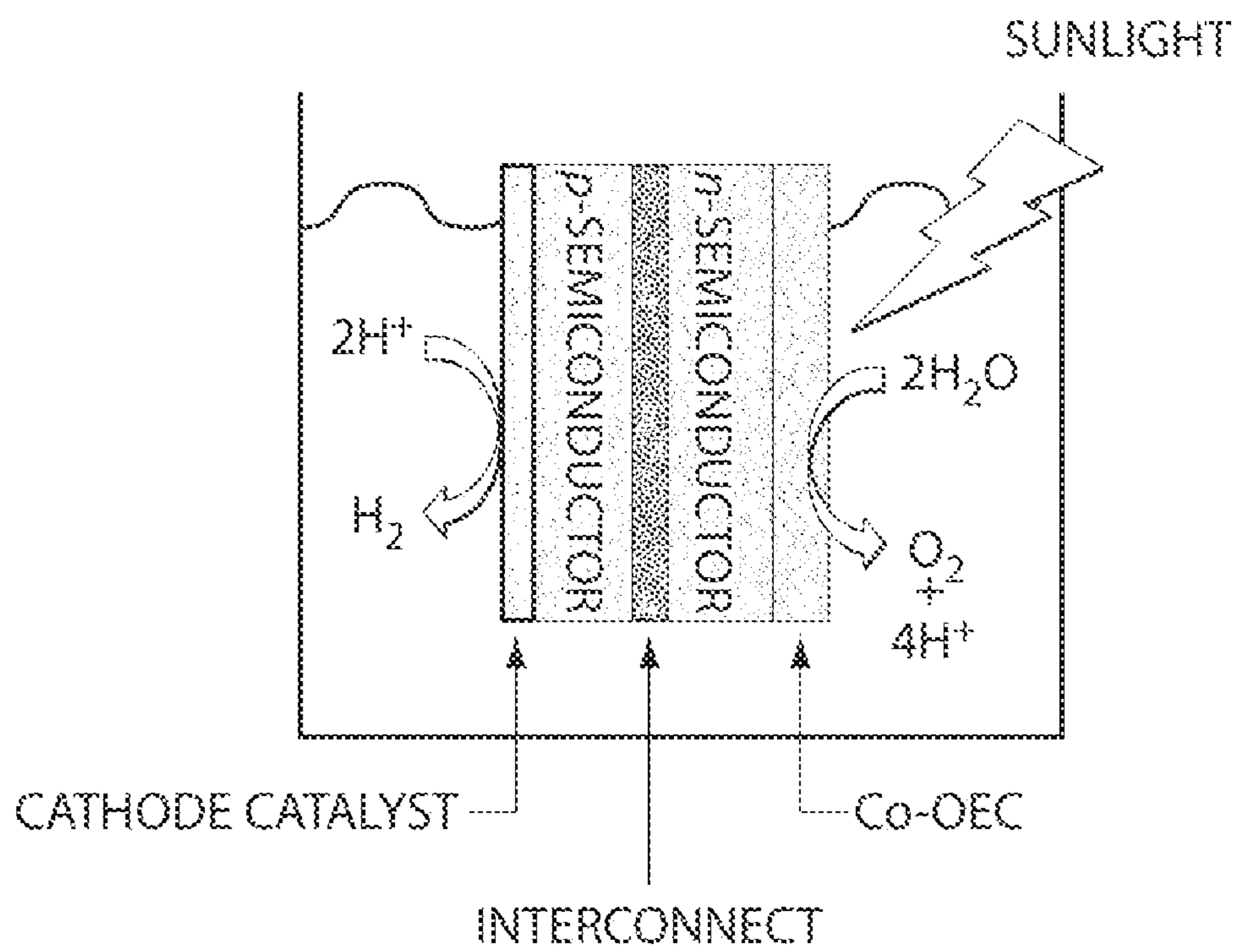

FIG. 17C

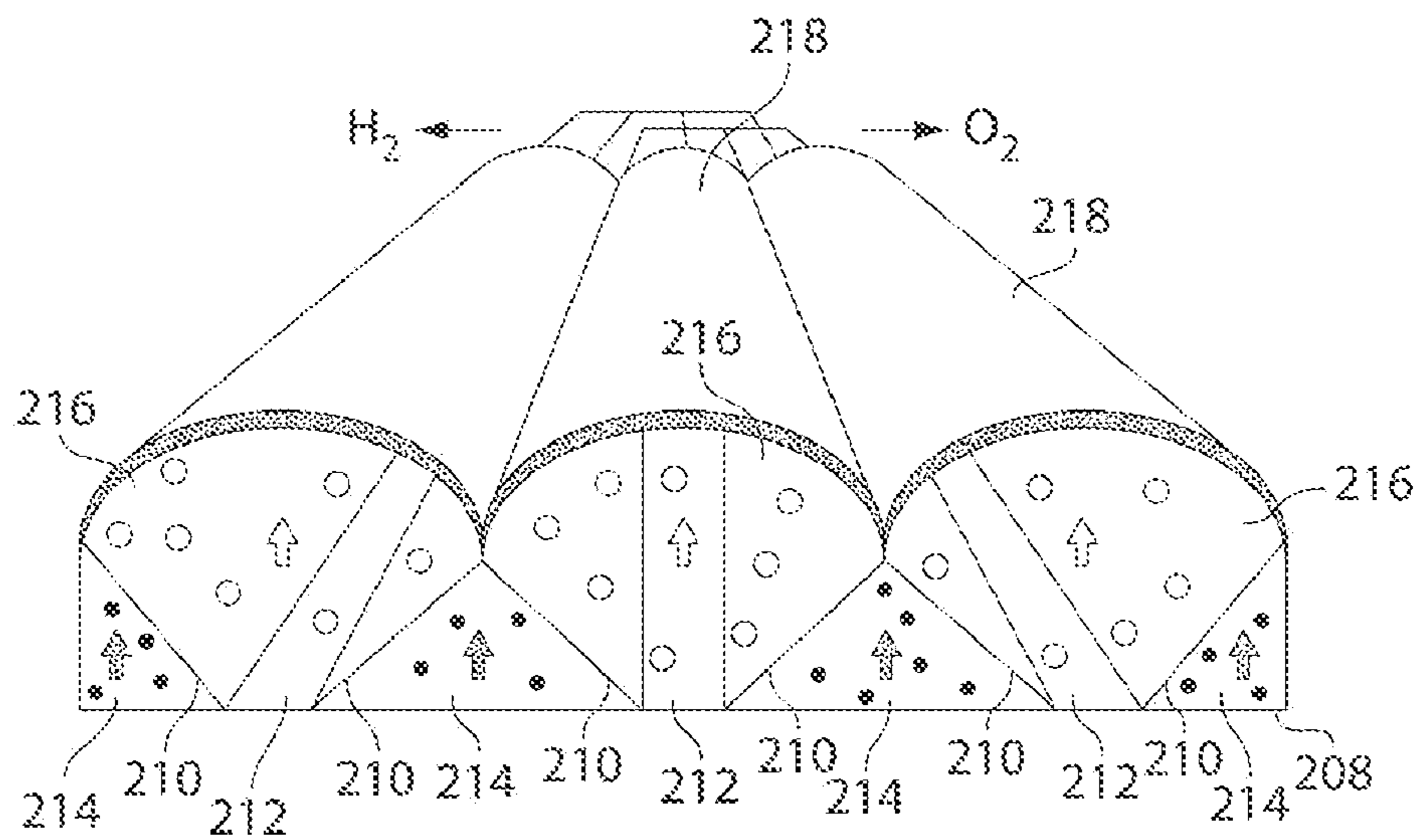

FIG. 17D

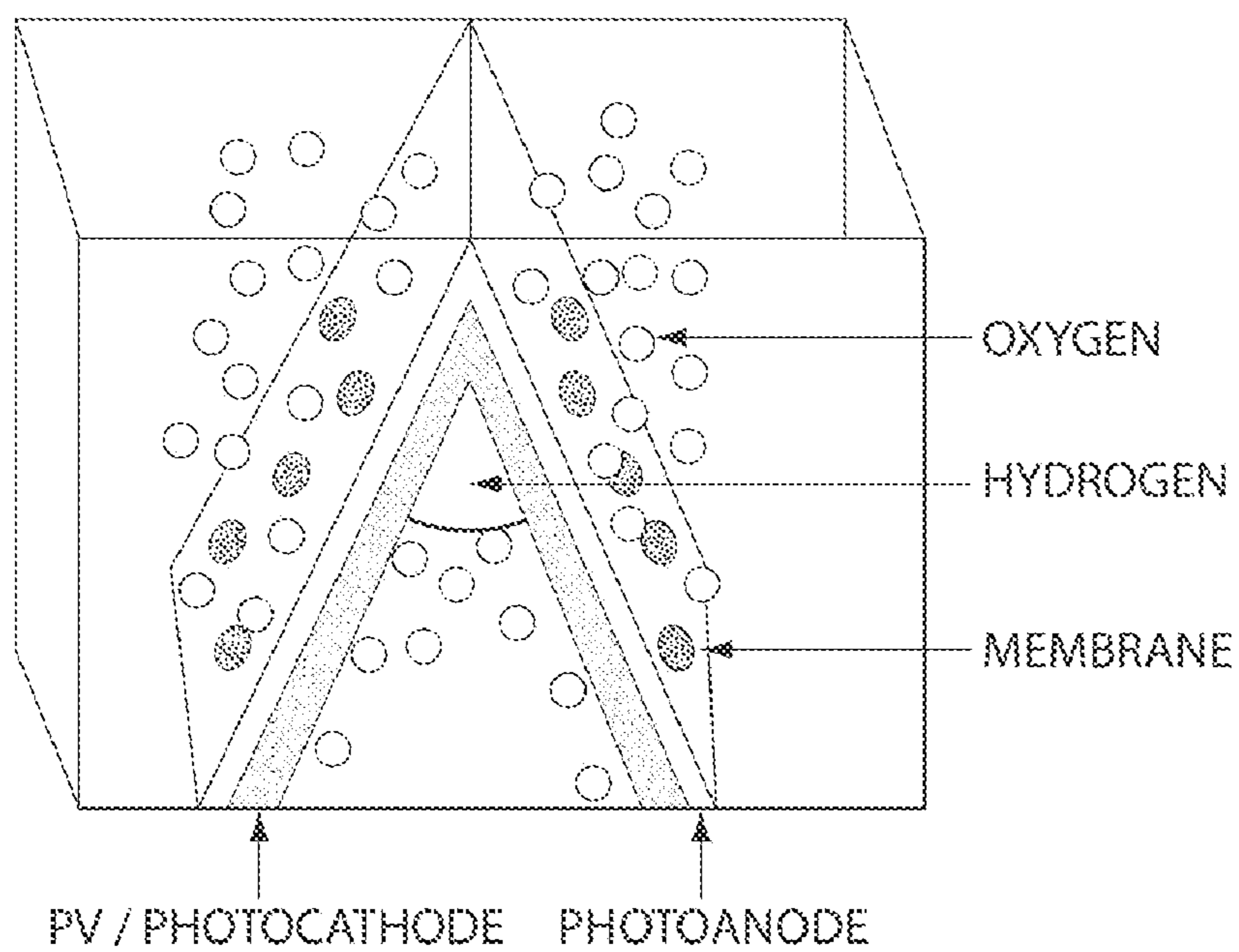

FIG. 17E

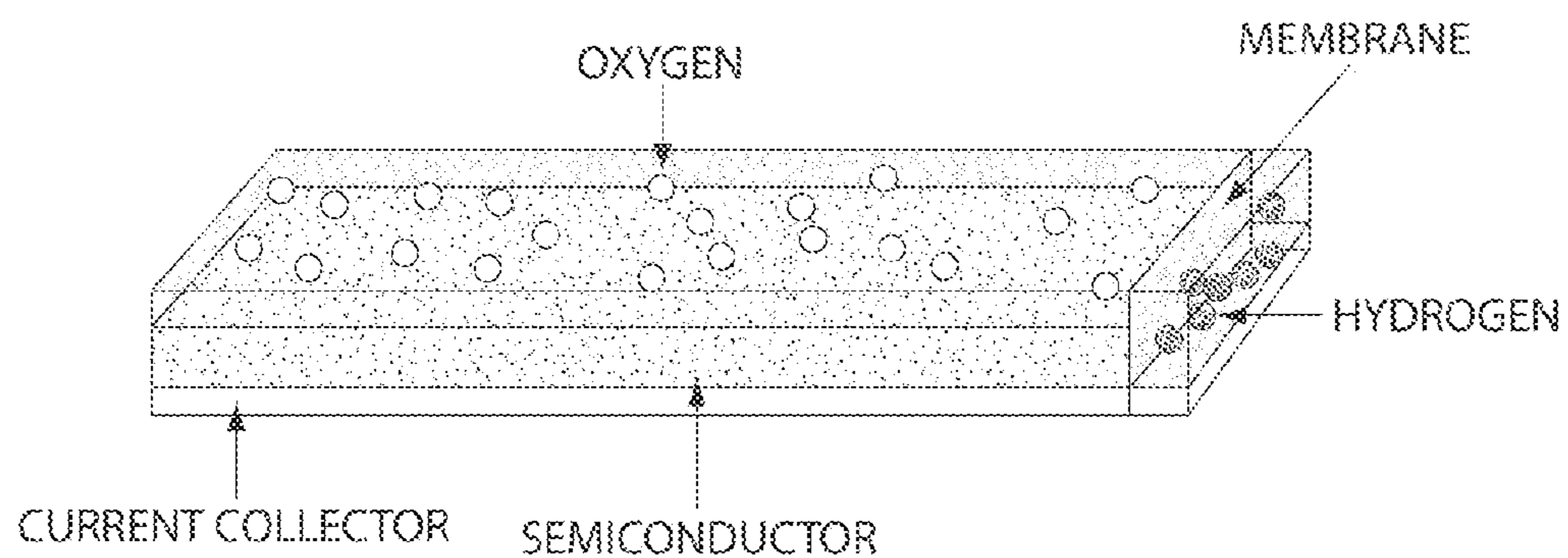

FIG. 17F

**CATALYTIC MATERIALS, PHOTOANODES,
AND PHOTOELECTROCHEMICAL CELLS
FOR WATER ELECTROLYSIS AND OTHER,
ELECTROCHEMICAL TECHNIQUES**

RELATED APPLICATIONS

[0001] This application claims the benefit of U.S. Provisional Patent Application Ser. No. 61/103,905, filed Oct. 8, 2008, entitled “Catalyst Compositions and Photoanodes for Photosynthesis Replication and Other Photoelectrochemical Techniques,” by Nocera, et al., and U.S. Provisional Patent Application Ser. No. 61/187,995, filed Jun. 17, 2009, entitled “Catalytic Materials, Photoanodes, and Systems for Water Electrolysis and Other Electrochemical Techniques,” by Nocera, et al., each herein incorporated by reference.

STATEMENT REGARDING FEDERALLY
SPONSORED RESEARCH OR DEVELOPMENT

[0002] This invention was made with the support under the following government contract F32GM07782903 awarded by the National Institutes of Health and CHE-0533150 awarded by the National Science Foundation. The government has certain rights in the invention.

FIELD OF THE INVENTION

[0003] The present invention relates to photoanodes for electrolysis of water which can be used for energy storage. The invention also relates to compositions and methods for forming a photoanode. In some embodiments, electrochemical devices such as photoelectrochemical devices are provided for the catalytic formation of oxygen gas and/or hydrogen gas from water.

BACKGROUND OF THE INVENTION

[0004] Solar energy can be considered to be a carbon-neutral energy source of sufficient scale to meet future global energy demand. The diurnal variation in local insolation, however, requires a cost-effective storage of solar energy for its large scale deployment as a primary energy source. In nature, photosynthesis captures sunlight and converts it into a wireless current which is stored. An approach to duplicating natural photosynthesis outside of a leaf is to capture and convert solar light into spatially separated electron/hole pairs within a photoelectrochemical cell. Photoelectrochemical devices may be used to produce hydrogen and oxygen gases from water. Photoelectrochemical devices utilize solar energy for the electrolysis of water, and generally employ a photoactive electrode, which, upon exposure to sunlight, produces electron/hole pairs that may be used for the electrolysis of water to produce hydrogen and/or oxygen gases. The net result is the storage of solar energy in the chemical bonds of H₂ and O₂.

[0005] In order to store energy via electrolysis, catalysts are required which efficiently mediate the bond rearranging “water splitting” reaction. The standard reduction potentials for the O₂/H₂O and H⁺/H₂ half-cells are given by Equation 1 and Equation 2.

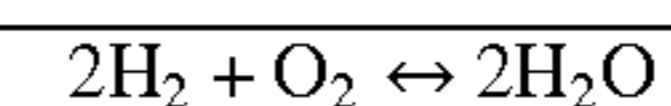
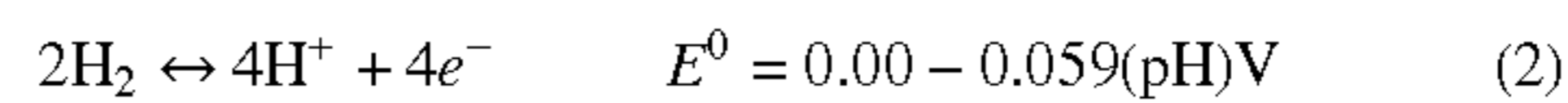
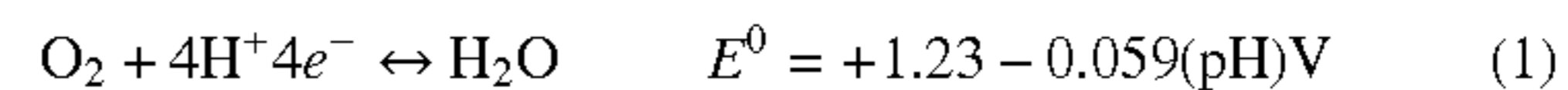

For a catalyst to be efficient for this conversion, the catalyst should operate at voltages close to the thermodynamic value of each half reaction, which are defined by half-cell potentials, E⁰. Voltage in addition to E⁰ that is required to attain a given catalytic activity, referred to as overpotential, limits the energy conversion efficiency. Considerable effort has been expended by many researchers in efforts to reduce overpotential in this reaction. It may be considered that oxygen gas production from water at low overpotential and under benign conditions using catalytic materials composed of earth-abundant materials presents the greatest challenge to water electrolysis. The oxidation of water to form oxygen gas requires the coupled transfer of four electrons and four protons to avoid high-energy intermediates. In addition to controlling multi-proton-coupled electron transfer reactions, a catalyst, in some cases, should also be able to tolerate prolonged exposure to oxidizing conditions.

[0006] While photoelectrochemical devices and photoanodes exist for the electrolysis of water, these devices are generally composed of expensive materials and/or operate with low energy conversion efficiencies. Therefore, a need remains for the development of improved materials and devices that operate with increased energy conversion efficiency.

SUMMARY OF THE INVENTION

[0007] The present invention relates to catalytic materials for electrolysis of water that can be used for energy storage, particularly in the area of solar energy conversion. The invention also relates to compositions and methods for forming a photoanode. In some embodiments, photoelectrochemical devices are provided for the catalytic formation of oxygen gas from water. The subject matter of the present invention involves, in some cases, interrelated products, alternative solutions to a particular problem, and/or a plurality of different uses of one or more systems and/or articles.

[0008] In one aspect, the invention is directed to a method. According to a first embodiment, a method for forming a photoanode for the catalytic production of oxygen from water comprises providing a solution comprising metal ionic species and anionic species, providing a photoactive electrode comprising a photoactive composition and a photosensitizing agent, and causing the metal ionic species and the anionic species to form a catalytic material associated with the photoactive electrode by application of a voltage to the photoactive electrode.

[0009] According to another embodiment, a method for producing oxygen from water, comprises the steps of providing a photoelectrochemical cell comprising a photoactive electrode comprising a photoactive composition and a photosensitizing agent, an electrolyte, and a catalytic material integrally connected to the photosensitizing agent, the catalytic material comprising metal ionic species and anionic species, and wherein the catalytic material does not consist essentially of a metal oxide or metal hydroxide, and illuminating the photoelectrochemical cell with light to thereby produce oxygen gas from water.

[0010] In another aspect, the invention is directed towards photoanodes. According to a first embodiment, a photoanode for the catalytic production of oxygen from water, comprises a photoactive electrode comprising a photoactive composition and a photosensitizing agent, and a catalytic material associated with the photoactive electrode, comprising cobalt ions and anionic species comprising phosphorus.

[0011] According to another embodiment, a photoanode for the catalytic production of oxygen from water comprises a photoactive electrode comprising a photoactive composition and a photosensitizing agent, and a catalytic material comprising metal ionic species and anionic species, wherein the metal ionic species with an oxidation state of $(n+x)$ and the anionic species define a substantially non-crystalline composition and have a K_{sp} value which is less, by a factor of at least 10^3 , than the K_{sp} value of a composition comprising the metal ionic species with an oxidation state of (n) and the anionic species.

[0012] According to yet another embodiment, a photoanode for the catalytic production of oxygen from water comprises a photoactive electrode comprising a photosensitizing agent and a photoactive composition, and a catalytic material comprising metal ionic species and anionic species, wherein the catalytic material is formed by application of a voltage to a photoactive electrode.

[0013] In yet another aspect, the invention relates to photoelectrochemical cells. According to a first embodiment, a photoelectrochemical cell comprises a photoanode comprising a photoactive electrode comprising a photoactive composition and a photosensitizing agent, and a catalytic material comprising metal ionic species and anionic species, wherein the catalytic material does not consist essentially of a metal oxide or metal hydroxide, at least one second electrode, and an electrolyte, wherein the photoelectrochemical cell is capable of producing oxygen gas from water.

BRIEF DESCRIPTION OF THE DRAWINGS

[0014] Non-limiting embodiments of the present invention will be described by way of example with reference to the accompanying figures, which are schematic and are not intended to be drawn to scale. Unless indicated as representing the prior art, the figures represent aspects of the invention. In the figures, each identical or nearly identical component illustrated is typically represented by a single numeral. For purposes of clarity, not every component is labeled in every figure, nor is every component of each embodiment of the invention shown where illustration is not necessary to allow those of ordinary skill in the art to understand the invention. In the figures:

[0015] FIG. 1 illustrates a non-limiting example of a photoelectrochemical cell, according to one embodiment.

[0016] FIG. 2 illustrates an energy diagram of a photoelectrochemical device comprising a photoactive electrode and an electrode, wherein the photoactive electrode is biased positively with respect to the electrode, according to one embodiment.

[0017] FIG. 3 illustrates an energy diagram of a photoelectrochemical cell comprising a first photoactive electrode and a second photoactive electrode, wherein the first photoactive electrode is biased positively with respect to the second photoactive electrode, according to one embodiment.

[0018] FIGS. 4A-4B illustrate the formation of a photoanode, according to one embodiment.

[0019] FIGS. 5A-5D illustrate examples of how a composition may associate with a photoactive electrode upon application of a voltage (e.g., a photovoltage) to the photoactive electrode, according to some embodiments.

[0020] FIG. 6 illustrates an energy diagram for a photoelectrochemical device comprising a photoactive electrode and an electrode, wherein the photoactive electrode is associated with a dye, according to one embodiment.

[0021] FIGS. 7A-7E illustrate the formation of a catalytic material on a photoactive electrode, according to one embodiment.

[0022] FIGS. 8A-8C illustrate a non-limiting example of a dynamic equilibrium of a catalytic material, according to one embodiment.

[0023] FIGS. 9A-9C represent an illustrative example of changes in oxidation state that may occur for a single metal ionic species during a dynamic equilibrium of an electrode, according to one embodiment, during use.

[0024] FIG. 10 shows a non-limiting embodiment of a hybrid photoelectrochemical cell.

[0025] FIG. 11 shows a non-limiting example of an electrochemical device.

[0026] FIG. 12 shows a non-limiting embodiment of a bi-photoelectrochemical cell.

[0027] FIG. 13 shows another non-limiting embodiment of a bi-photoelectrochemical cell.

[0028] FIG. 14 shows a SEM image of a catalytic material comprising cobalt electrodeposited onto a thin film of CdS, according to a non-limiting embodiment.

[0029] FIG. 15 shows SEM images of a thin film CdS electrode treated with a solution of 0.1M MePi (pH 8.5) and 2 mM Co^{2+} in the (A) presence and (B) absence of irradiation with visible light, according to a non-limiting embodiment.

[0030] FIG. 16 shows the band edge positions of various forms of TiO_2 along with the standard reduction potential of the hydroxyl radical and the potential for operation of the CoPi catalyst, according to some embodiments.

[0031] FIGS. 17A-17F illustrate non-limiting examples of photoelectrochemical cells.

[0032] Other aspects, embodiments, and features of the invention will become apparent from the following detailed description when considered in conjunction with the accompanying drawings. The accompanying figures are schematic and are not intended to be drawn to scale. For purposes of clarity, not every component is labeled in every figure, nor is every component of each embodiment of the invention shown where illustration is not necessary to allow those of ordinary skill in the art to understand the invention. All patent applications and patents incorporated herein by reference are incorporated by reference in their entirety. In case of conflict, the present specification, including definitions, will control.

DETAILED DESCRIPTION

[0033] The present invention relates to photoanodes for electrolysis of water which can be used for energy storage. The invention also relates to compositions and methods for forming a photoanode. In some embodiments, photoelectrochemical devices are provided for the catalytic formation of oxygen gas and/or hydrogen gas from water. The invention allows for the facile, low-energy conversion of water to hydrogen gas and/or oxygen gas using a photoactive electrode. In some cases, the conversion may be driven by exposing the photoactive electrode to electromagnetic radiation (e.g., sunlight). Energy can be stored, via the catalytic mate-

rial of the invention, in the form of oxygen gas and hydrogen gas. The hydrogen and oxygen gases can be recombined at any time, for example, later as a stored source of energy, whereby they form water and release significant energy that can be captured in the form of mechanical energy, electricity, or the like. In other cases, the hydrogen and/or oxygen gases may be used in another process.

[0034] According to some embodiments, compositions and methods for forming a photoanode are provided. In some cases, a photoanode may catalytically produce oxygen gas from water. As shown in Equation 1, water may be split to form oxygen gas, electrons, and hydrogen ions. Although it need not be, a photoanode of the invention can be operated in benign conditions (e.g., neutral or near-neutral pH, ambient temperature, ambient pressure, etc.). A photoanode may comprise a photoactive electrode, metal ionic species and anionic species, wherein the metal ionic species and anionic species are associated with the photoactive electrode. The metal ionic species and anionic species may be selected such that, when exposed to an aqueous solution (e.g., an electrolyte), the metal ionic species and anionic species are in dynamic equilibrium with the aqueous solution, as described herein.

[0035] Photoanodes of the present invention, in some cases, comprise a catalytic material. Many species of the class of catalytic material provided by the invention are made of readily-available, low-cost material, and are easy to make. Accordingly, the invention has the potential to dramatically change the field of solar energy capture, storage, and use. The subject matter of the present invention involves, in some cases, interrelated products, alternative solutions to a particular problem, and/or a plurality of different uses of one or more systems and/or articles.

[0036] In all descriptions of the use of water (e.g., for the production of oxygen gas) for catalysis herein, it is to be understood that the water may be provided in a liquid and/or gaseous state. The water used may be relatively pure, but need not be, and it is one advantage of the invention that relatively impure water can be used. The water provided can contain, for example, at least one impurity (e.g., halide ions such as chloride ions). In some cases, the device may be used for desalination of water. It should be understood that while much of the application herein focuses on the catalytic formation of oxygen gas from water, this is by no means limiting, and the compositions, photoanode, methods, and/or systems described herein may be used for other catalytic purposes, as described herein.

[0037] In some embodiments, photoanodes are provided which may produce oxygen gas from water. As shown in Equation 1, water may be split to form oxygen gas, electrons, and hydrogen ions. Although it need not be, an electrode may be operated in benign conditions (e.g., neutral or near-neutral pH, ambient temperature, ambient pressure, etc.). In some cases, the electrodes described herein operate catalytically. That is, an electrode may be able to catalytically produce oxygen gas from water, but the electrode may not necessarily participate in the related chemical reactions such that it is consumed to any appreciable degree. Those of ordinary skill in the art will understand the meaning of “catalytically” in this context. An electrode may also be used for the catalytic production of other gases and/or materials.

[0038] As used herein, a photoanode is a photoactive electrode, in addition to any catalytic material adsorbed thereto. In some embodiments, the photoactive electrode may comprise a photoactive composition and a photosensitizing agent.

The catalytic material may comprise metal ionic species and anionic species, wherein the metal ionic species and anionic species are associated with the photoactive electrode. The metal ionic species and anionic species may be selected such that, when exposed to an aqueous solution (e.g., an electrolyte or water source), the metal ionic species and anionic species are in dynamic equilibrium with the aqueous solution, as described herein.

[0039] In some embodiments, a photoanode of the present invention comprises a photoactive electrode and a catalytic material associated with the photoactive electrode. A “catalytic material” as used herein, means a material that is involved in and increases the rate of a chemical electrolysis reaction (or other electrochemical reaction) and which, itself, undergoes reaction as part of the electrolysis, but is largely unconsumed by the reaction itself, and may participate in multiple chemical transformations. A catalytic material may also be referred to as a catalyst and/or a catalyst composition. A catalytic material is not simply a bulk photoactive electrode material which provides and/or receives electrons from an electrolysis reaction, but a material which undergoes a change in chemical state of at least one ion during the catalytic process. For example, a catalytic material might involve a metal center which undergoes a change from one oxidation state to another during the catalytic process. In another example, the catalytic material might involve metal ionic species which bind to one or more oxygen atoms from water and release the oxygen atoms as dioxygen (i.e., O₂). Thus, catalytic material is given its ordinary meaning in the field in connection with this invention. As will be understood from other descriptions herein, a catalytic material of the invention that may be consumed in slight quantities during some uses and may be, in many embodiments, regenerated to its original chemical state.

[0040] “Electrolysis,” as used herein, refers to the use of an electric current to drive an otherwise non-spontaneous chemical reaction. For example, in some cases, electrolysis may involve a change in redox state of at least one species and/or formation and/or breaking of at least one chemical bond, by the application of an electric current. Electrolysis of water, as provided by the invention, can involve splitting water into oxygen gas and hydrogen gas, or oxygen gas and another hydrogen-containing species, or hydrogen gas and another oxygen-containing species, or a combination.

[0041] In some embodiments, methods are provided for forming a photoanode comprising a photoactive electrode (e.g., an n-type semiconductor photoactive material), metal ionic species, and anionic species. The photoanode may be formed by exposing a photoactive electrode to a solution comprising metal ionic species and anionic species, followed by application of a voltage to the photoactive electrode. The term “application of a voltage,” as used herein, in some embodiments, is synonymous with the term formation of a photovoltage (e.g., formation of electron/hole pairs in a material by exposing the material to electromagnetic radiation). For example, the voltage may be applied to a photoactive electrode by an external power source (e.g., a battery) or by exposing a photoactive electrode to electromagnetic radiation (e.g., sunlight, to produce a photovoltage), as described herein. The metal ionic species and anionic species may associate with the photoactive electrode and form a composition (e.g., a catalytic material) associated with the photoactive electrode. In some cases, when associating with the photoac-

tive electrode, the metal ionic species may be oxidized or reduced as compared to the metal ionic species in solution, as described herein.

[0042] In some embodiments, photoelectrochemical devices are provided which comprise a photoanode as described herein. In some embodiments, photoelectrochemical devices comprising a photoanode as described herein are capable of catalytically producing oxygen gas from water. In some cases, the device may additionally produce hydrogen gas. Devices are described herein.

[0043] Without wishing to be bound by theory, the devices and methods as described herein may be used for the photoelectrolysis of water and conversion of light to electrical energy, and in some cases, solely use solar energy (e.g., sunlight) as the power source. For example, a photoanode as described herein may comprise a catalytic material associated with an n-type semiconductor photoactive electrode. When the photoanode is exposed to light, electrons are excited from the valence band to the conduction band of the n-type semiconductor, thereby creating holes in the valence band and free electrons in the conduction band. In some embodiments, the excited electron and corresponding electron-hole may separate spatially within the semiconductor material from the point of generation. Such charge separation may give rise to a photovoltage within the semiconductor. The electron-holes may be transported to the semiconductor-electrolyte interface, where they may react with a water molecule (e.g., via a catalytic material), resulting in the formation of oxygen gas and/or hydrogen ions. The electrons produced at the photoanode may be conducted by means of an external electrical connection to the counter electrode where they may combine with hydrogen ions of water molecules (or another source such as an acid) in the electrolytic solution to produce hydrogen gas. In instances where the conduction band level of the semiconductor is more negative than the H_2O/H_2 energy level and the valence band level of the semiconductor is more positive than the O_2/H_2O energy level, the electrolysis of water may be accomplished solely through the use of solar energy (e.g., without the use of an external power source). In some cases, association of a catalytic material with a photoactive electrode (e.g., a photoanode as described herein) may cause the efficiency and/or yield of the formation of oxygen to increase as compared to the photoactive electrode itself, when operated under essentially identical conditions, as described herein.

[0044] There are many benefits to photoanodes and to the methods for producing photoanodes as described herein. For example, the method for forming a photoanode is easily adaptable and may be used to produce photoanodes of varying sizes and shapes, as described herein. In addition, the photoanodes produced by the provided methods can be robust and long-lived, and can be resistant to poisoning by acidic and/or basic conditions and/or environmental conditions (e.g., the presence of carbon monoxide). Photoanode poisoning may be thought of as any chemical or physical change in the status of the photoanode that may diminish or limit the use of a photoanode in a photoelectrochemical device and/or lead to erroneous measurements. Photoanode poisoning may manifest itself as the development of unwanted coatings, and/or precipitates, on the photoanode, or dissolution and/or erosion of the photoanode. For example, some photoactive electrodes (e.g., CdS, CdSe, GaAs, GaP) which may be employed in a photoanode as described herein, may be subject to surface reactions in aqueous, acidic, and/or basic con-

ditions. In some embodiments, the presence of the catalytic material associated with the photoactive electrode may help prevent and/or reduce unwanted surface reactions as opposed to a photoactive electrode which does not comprise the catalytic material.

[0045] Methods of making a photoanode as described herein also represent a significant development. In some embodiments, photoanodes are provided which are made from materials which are easily, reproductively, and inexpensively made. In some embodiments, a photoanode may be formed by immersing a photoactive electrode (e.g., hematite, TiO_2 , etc.) in a solution comprising metal ionic species and anionic species. Application of a voltage to the photoactive electrode may cause the metal ionic species and the anionic species to associate with the photoactive electrode to form a catalytic material associated with the photoactive electrode, thereby forming the photoanode. In some cases, association of the metal ionic species with the photoactive electrode may comprise a change in oxidation state of the metal ionic species from (n) to (n+x), wherein x may be 1, 2, 3, and the like.

[0046] The invention can also be characterized in terms of performance of the catalytic material of the invention (and/or photoanode comprising the catalytic material). One way of doing this, among many, is to compare the energy conversion efficiency and/or the current density of the photoanode versus the photoactive electrode alone. Typical photoactive electrodes are described more fully herein and may comprise Fe_2O_3 , TiO_2 , and the like. The photoactive electrode may be able to function, itself, as a catalytic photoanode for water electrolysis, and may have been used in the past to do so. So, comparison of the energy conversion efficiency and/or the current density during catalytic water electrolysis (where the photoanode catalytically produces oxygen gas from water), using the photoactive electrode, as compared to essentially identical conditions (with the same counter electrode, same electrolyte, same circuitry, same water source, etc.), using the photoanode of the invention including both photoactive electrode and catalytic material, can be compared. In most cases, the energy conversion efficiency and/or the current density of the photoanode is greater than the energy conversion efficiency and/or the current density of the photoactive electrode alone, where each is tested independently under essentially identical conditions.

[0047] In some cases, the energy conversion efficiency of the photoanode comprising the composition may be at least about 5%, at least about 10%, at least about 15%, at least about 20%, at least about 30%, at least about 40%, at least about 50%, at least about 60% at least about 70%, at least about 80%, at least about 90%, at least about 100%, at least about 150%, at least about 200%, or greater, than the efficiency of the photoactive electrode alone, operated under essentially identical conditions. The increase in energy conversion efficiency may be determined operating a photoanode as described herein (e.g., comprising a photoactive electrode and catalytic material) and the photoactive electrode under essentially identical conditions and comparing the results. Energy conversion efficiency is the ratio between the useful output of an energy conversion device and the input, in energy terms and techniques for measuring the efficiency, as will be known to those of ordinary skill in the art. In some cases, the current density of the photoanode may be greater than the current density of the photoactive electrode by a factor of at least about 10, about 100, about 1000, about 10^4 , about 10^5 , about 10^6 , about 10^8 , about 10^{10} , and the like. In some

embodiments, the current density of the photoanode may exceed the current density of the photoactive electrode by a factor between about 10^4 and about 10^{10} , between about 10^5 and about 10^9 , or between about 10^4 and about 10^8 . The current density may either be the geometric current density or the total current density, as described herein.

[0048] In some embodiments, an electrochemical cell comprising at least a first electrode, a second electrode, and an electrolyte, wherein at least one electrode is capable of converting solar energy into an electrochemical potential and used for water electrolysis is provided. In a first non-limiting embodiment, the first electrode may comprise an n-type semiconductor electrode (e.g., comprising a catalytic material) and a second electrode comprises a conductor (e.g., a metal), wherein the first electrode may be biased positively with respect to the second electrode. In some cases, the bias may be supplied by a photovoltaic cell. In a second non-limiting embodiment, the first electrode comprises an n-type semiconductor and the second electrode comprises a p-type semiconductor (e.g., a tandem configuration), wherein the first electrode is biased positively with respect to the second electrode. In a third non-limiting embodiment, the first electrode comprises a conductor (e.g., a metal) and the second electrode comprises a p-type semiconductor, wherein the first electrode may be biased positively with respect to the second electrode.

[0049] In one embodiment, the processes that may occur in a photoelectrochemical cell are as follows. The first electrode may be exposed to electromagnetic radiation, wherein the first electrode comprises an n-type semiconductor and may be biased positively with respect to a second electrode. The light may excite the semiconducting material of the first electrode, and result in the formation of electronic charged carriers (e.g., electron/hole pairs). Water may be oxidized by the electron holes produced at the first electrode. The hydrogen ions produced at the first electrode may be transported (e.g., through the electrolyte) to the second electrode, and the electrons produced at the first electrode may be transferred to the second electrode through an external circuit. The transported hydrogen ions (e.g., H^+ or another form such as $H_2PO_4^-$) may be reduced with transported electrons at the second electrode, thereby forming hydrogen gas. FIG. 1 illustrates one possible arrangement of a photoelectrochemical cell and is described herein.

[0050] The photovoltage of the n-type semiconducting material may be related to the energy of the electromagnetic radiation as well as to the band gap of the material. The band gap of a material is the energy difference between the top of the valence band and the bottom of the conduction band, as will be known to those of ordinary skill in the art. If a photon has energy greater than or equal to the band gap of the material, then electrons can form in the conduction band and holes can form in the valence band, related by the following Equation 3:

$$h\nu \rightarrow e' + h. \quad (3)$$

where h is Planck's constant, ν is the frequency of the photon, e' is an electron, and $h.$ is an electron hole. Generally, an electric field or bias (e.g., provided through doping of the semiconductor material and/or through the application of an external voltage) may be required at the photoactive electrode/electrolyte interface to avoid recombination of the electron and the hole.

[0051] In some embodiments, the process that takes place at the first electrode which is biased positively with respect to the second electrode is shown in Equation 4.

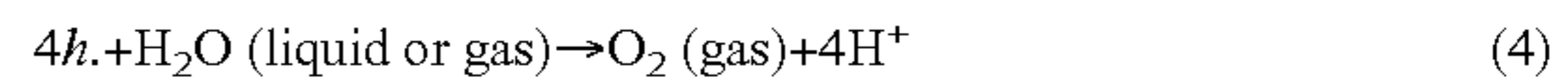

The process shown in Equation 4, in some cases, may take place at the first electrode/electrolyte interface. This process produces oxygen gas which may be released, stored, and/or used in various devices/methods. The electrons and the hydrogen ions may combine at the second electrode to form hydrogen gas, as shown in Equation 5.



The overall reaction that takes place is shown in Equation 6.

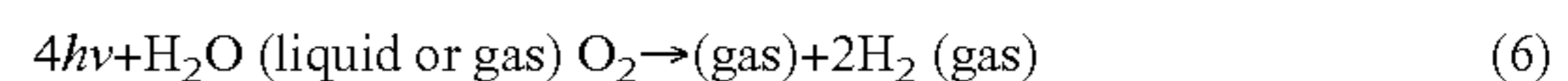

The overall reaction can occur if the energy of the photons absorbed by the first electrode is equal to or greater than the threshold energy, E_t , which are related by Equation 7:

$$E_t = \frac{\Delta G_{H_2O}^\circ}{4} \quad (7)$$

where $\Delta G_{H_2O}^\circ$ is the standard free energy of the reaction shown in Equation 6 (4.92 eV). E_t is equal to 1.23 eV and the electrolysis of water is possible when the electromotive force of the photoelectrochemical device is equal to or greater than 1.23 eV. It should be understood, however, that in some embodiments, the proton may be associated with a species and may be transported via association with a species in solution (e.g., a buffer species). The thermodynamics discussed above, in most cases, would be applicable in such embodiments.

[0052] It should be understood, that photoanodes as described herein may be formed prior to incorporation into a device or may be formed during operation of a device. For example, in some cases, a photoanode may be formed using methods described herein (e.g., exposing a photoactive electrode to a solution comprising metal ionic species and anionic species, followed by application of a voltage to the photoactive electrode and association of catalytic material comprising the metal ionic species and anionic species with the photoactive electrode). The photoanode may then be incorporated into a device. As another example, in some cases, a device may comprise a photoactive electrode, and a solution (e.g., electrolyte) comprising metal ionic species and anionic species. Upon operation of the device (e.g., application of a voltage to the photoactive electrode), a catalytic material (e.g., comprising the metal ionic species and anionic species from the solution) may associate with the photoactive electrode, thereby forming the photoanode in the device. After formation of the photoanode, the photoanode can be used for purposes described herein with or without change in environment (e.g., change in solution or other medium to which the electrode is exposed), depending upon the desired formation and/or use medium, which would be apparent to those of ordinary skill in the art.

[0053] FIG. 2 shows an energy diagram of a photoelectrochemical cell comprising a photoactive electrode and an electrode, wherein the photoactive electrode is biased positively with respect to the electrode and comprises an n-type semiconductor (e.g., a photoanode). In this figure, E_F is the Fermi energy, E_C and E_V are the energies of the bottom of the con-

duction band and the top of the valence band, respectively, of the photoanode, and E_g is the band gap. For the cell to operate, the oxygen energy levels (O_2/H_2O) should be above the valence band of the photoanode for electron-hole transfer to occur, and for the same reason, the hydrogen energy level (H^+/H_2) should be below the Fermi level of the electrode (e.g., when the electrode is a conductor). In some cases, a photoelectrochemical device may require an external bias (e.g., voltage) in order for the photoelectrochemical device to operate. Application of an external bias may aid in creating increased charge separation between the electron/hole pairs at the photoanode as compared to a photoanode without a charge bias. In some embodiments, a charge bias of at least about 0.1 V, at least about 0.3 V, at least about 0.5 V, at least about 1.0 V, at least about 2.0 V, or greater, may be provided to the photoelectrochemical device. The charge bias may aid in reducing the probability of recombination of an electron in the conduction band and a hole created in the valence band upon the absorption of light energy. Some possible arrangements of photoelectrochemical devices are described herein.

[0054] FIG. 3 shows the energy diagram of a photoelectrochemical device comprising a first photoactive electrode (e.g., an n-type semiconductor) and a second photoactive electrode (e.g., a p-type semiconductor). The intrinsic nature of the band position leads to the first photoactive electrode being “biased” positively with respect to the second photoactive electrode (although no external bias is provided, e.g., via a power source). This type of photoelectrochemical device may be referred to as a bi-photoelectrochemical cell or a tandem photoelectrochemical cell. In the figure, E_F is the Fermi energy, E_C and E_V are the energies of the bottom of the conduction band and the top of the valence band, respectively, of the photoactive electrodes, and E_g is the band gap for each photoactive electrode. A bi-photoelectrochemical cell may be able to operate using only solar energy without the need for an external bias, e.g., as may be generally required for a photoelectrochemical cell comprising a single photoactive electrode. Various possible arrangements for a bi-photoelectrochemical cell are described herein. Additional devices that may be used in combination with a photoanode are also discussed in more detail below.

[0055] In some embodiments, a method of forming a photoanode comprises causing metal ionic species and anionic species to associate with a photoactive electrode by application of a voltage to the photoactive electrode. In some embodiments, the method may comprise providing a solution containing metal ionic species and anionic species and immersing a photoactive electrode in the solution, followed by application of voltage to the photoactive electrode. A non-limiting example of formation of a photoanode is shown in FIG. 4. FIG. 4A shows a container 110 comprising a photoactive electrode 112 and a solution 114 in which are suspended, but more typically dissolved, metal ionic species 116 and anionic species 118. In some cases, the photoactive electrode is in electrical communication 120 with a power source (not shown). FIG. 4B shows the same experimental set-up upon application of voltage to the photoactive electrode by the power source. In some cases, however, voltage may be applied to the photoactive electrode by exposing the photoactive electrode to electromagnetic radiation or by an external power source (e.g., a battery). Metal ionic species 122 and anionic species 124 associate with the photoactive electrode 126 to form a composition (e.g., a catalytic material) 128 associated with the photoactive electrode. The catalytic material may be transparent, substantially transparent,

substantially opaque, and/or opaque. In a particular embodiment, the catalytic material is transparent and/or substantially transparent.

[0056] In some cases, voltage may be applied to a photoactive electrode by a power source. For example, voltage may be applied to the photoactive electrode by batteries, power grids, regenerative power supplies (e.g., wind power generators, photovoltaic cells, tidal energy generators, etc.), generators, and the like. The power source may comprise one or more of such power supplies (e.g., batteries and a photovoltaic cell). The voltage applied may be AC or DC. In such embodiments, the voltage applied to the photoactive electrode may be substantially similar to all surfaces of the area. In some cases, the thickness of the composition formed on the photoactive electrode is substantially uniform across the areas where the composition is present. For example, as shown in FIG. 5A, application of voltage to photoactive electrode 2 through wire 4 connected to an outside power source which is immersed in solution 6 comprising metal ionic species and anionic species causes composition 8 to associate with photoactive electrode 2.

[0057] In other cases, voltage (e.g., photovoltage) may be applied to the photoactive electrode by exposing the photoactive electrode to electromagnetic radiation (e.g., sunlight). As described herein, application of electromagnetic radiation to a photoactive electrode may cause the production of electron/hole pairs to form (e.g., formation of a photovoltage). In some instances, the photoactive electrode may be exposed to varying levels of electromagnetic radiation. For example, some surfaces of the photoactive electrode may be exposed to a differing electromagnetic radiation (e.g., wavelength or range of wavelengths, time of exposure, power (e.g., wattage, etc.)), than other surfaces of the photoactive electrode. In some cases, at least a portion of all the surfaces of the photoactive electrode are exposed to substantially similar electromagnetic radiation. In some cases, surfaces which are exposed to a solution comprising metal ionic species and anionic species are exposed to electromagnetic radiation, while in other cases, surfaces which are not exposed to a solution comprising metal ionic species and anionic species are exposed to electromagnetic radiation. In some instances, the thickness of the composition associated with the photoanode may or may not be substantially similar in the areas of the photoactive electrode which are exposed to electromagnetic radiation. In some cases, the areas of the photoactive electrode which are more active (e.g., produce more electron/hole pairs in that area), may comprise a catalytic material which is thicker than the composition in areas which are less active (e.g., produce less electron/hole pairs in that area). For example, as shown in FIGS. 5B and 5C, exposing photoactive electrode 2 to electromagnetic radiation 10 causes composition 8 to associate with photoanode. In some cases, the composition may associate with only the areas which were directly exposed to light as shown in FIG. 5B (e.g., surface 12 was exposed to light and is associated with composition 8). In other cases, substantially all surfaces may be associated with the composition upon exposure to electromagnetic radiation, as shown in FIG. 5C (e.g., surface 12 was exposed to light and both surface 12 and 14 are associated with composition 8), for example, in instances where the photoactive electrode is substantially transparent.

[0058] In some cases, some areas of the photoactive electrode may be disproportionately exposed to electromagnetic radiation at a level greater than exposure at other areas of the photoactive electrode, such that the formation of a composition is greater in areas that were exposed to greater levels of electromagnetic radiation than areas that received less elec-

tromagnetic radiation. For example, in some embodiments, the photoactive electrode may be exposed to patterned electromagnetic radiation which may allow for the formation of the composition in a pattern. Various techniques may be employed, for example, passing electromagnetic radiation through a mask (e.g., lithographical techniques). For example, as shown in FIG. 5D, photoactive electrode 2 is exposed to electromagnetic radiation through mask 16 such that selected areas of the photoactive electrode are exposed to electromagnetic radiation. The areas of the photoactive electrode that were exposed to light comprise composition 8. The boundaries between areas which comprise the composition and areas which do not comprise the composition may be sharp (e.g., the thickness of a composition in an area is substantially uniform throughout) or gradual (e.g., the thickness of the composition in an area is not substantially uniform and/or the thickness of the composition decreases away from the center of the area).

[0059] Electromagnetic radiation (e.g., in the formation of the composition associated with the photoactive electrode or during operation of a device as described herein) may be provided by any suitable source. For example, electromagnetic radiation may be provided by sunlight and/or an artificial light source. In an exemplary embodiment, the electromagnetic radiation is provided by sunlight. In some embodiments, light may be provided by sunlight at certain times of operation of a device (e.g., during daytime, on sunny days, etc.) and artificial light may be used at other times of operation of the device (e.g., during nighttime, on cloudy days, etc.). Non-limiting examples of artificial light sources include a lamp (mercury-arc lamp, a xenon-arc lamp, a quartz tungsten filament lamp, etc.), a laser (e.g., argon ion), and/or a solar simulator. The spectra of the artificial light source may be substantially similar or substantially different than the spectra of natural sunlight. The light provided may be infrared (wavelengths between about 1 mm and about 750 nm), visible (wavelengths between about 380 nm and about 750 nm), and/or ultraviolet (wavelengths between about 10 nm and about 380 nm). In some cases, the electromagnetic radiation may be provided at a specific wavelength, or specific ranges of wavelengths, for example, through use of a monochromatic light source or through the use of filters. The power of the electromagnetic radiation may also be varied. For example, the light source provided may have a power of at least about 100 W, at least about 200 W, at least about 300 W, at least about 500 W, at least about 1000 W, or greater. The formation and properties of the composition are described herein.

[0060] In some cases, the photoactive electrode associated with a catalytic material as described herein may comprise a photoactive composition, such as an n-type semiconductor. The photoactive composition may be selected such that the band gap is between about 1.0 and about 2.0 eV, between about 1.2 and about 1.8 eV, between about 1.4 and about 1.8 eV, between about 1.5 and about 1.7 eV, is about 2.0 eV, or the like. The photoactive composition may also have a Fermi level which is compatible with the electrolyte and/or a small work function (e.g., such that electrons may diffuse into the water to attain thermal equilibrium). This may cause the energy bands of the photoactive composition to bend up near the interface of the electrolyte. In some cases, the photoactive electrode may be transparent, substantially transparent, substantially opaque, or opaque. In an exemplary embodiment, the photoactive electrode and the composition associated with the photoactive electrode are transparent and/or substantially transparent. The photoactive electrode may be a solid, semi-porous or porous. Non-limiting examples of photoac-

tive compositions (or, in some cases, n-type semiconducting materials) include TiO_2 , WO_3 , SrTiO_3 , $\text{TiO}_2\text{—Si}$, BaTiO_3 , $\text{LaCrO}_3\text{—TiO}_2$, $\text{LaCrO}_3\text{—RuO}_2$, $\text{TiO}_2\text{—In}_2\text{O}_3$, GaAs, GaP, p-GaAs/n-GaAs/pGa_{0.2}In_{0.48}P, AlGaAs/SiRuO₂, PbO, FeTiO₃, KTaO₃, MnTiO₃, SnO₂, Bi₂O₃, Fe₂O₃ (including hematite), ZnO, CdS, MoS₂, CdTe, CdSe, CdZnTe, ZnTe, HgTe, HgZnTe, HgSe, ZnTe, ZnS, HgCdTe, HgZnSe, etc., or composites thereof. In some cases, the photoactive composition may be doped. For example, TiO₂ may be doped with Y, V, Mo, Cr, Cu, Al, Ta, B, Ru, Mn, Fe, Li, Nb, In, Pb, Ge, C, N, S, etc., and SrTiO₃ may be doped with Zr. The photoactive composition may be provided in any suitable morphology or arrangement, for example, including single crystal wafers, coatings (e.g., thin films), nanostructured arrays, nanowires, etc. Those of ordinary skill in the art will be aware of methods and techniques for preparing a photoactive composition in a chosen form. For example, doped TiO₂ may be prepared by sputtering, sol-gel, and/or anodization of Ti.

[0061] In an exemplary embodiment, the photoactive composition may comprise alpha-Fe₂O₃, also known as hematite. In some embodiments, hematite may be doped, for example, with Nb, Si, or In. Hematite has a band gap of about 2 eV and in some cases, has been found to absorb about 40% of the solar flux at ground level. Hematite may be provided in any suitable arrangement, for example, as a single crystal, as a coating (e.g., film) on a surface of a material (e.g., SnO₂ glass, Ti, etc.), as nanowires (e.g., on a material), etc.

[0062] In some cases, the photoactive electrode may consist essentially of the photoactive composition (e.g., the photoactive composition forms the photoactive electrode). In such cases, the photoactive composition may be a single crystal or polycrystalline. The photoactive composition may or may not comprise interfaces (e.g., grain boundaries, surface linear defects, etc.). In some cases, the macroscale (e.g., properties representative of the composition as a continuum such as electronic structure, Fermi energy, etc.) and microscale properties (e.g., properties of specific sites on the surface such as surface-active centers formed by surface defects) of the photoactive composition may be found to effect the reactivity and photoreactivity of the photoactive composition.

[0063] In other cases, the photoactive electrode may not consist essentially of the photoactive composition. For example, the photoactive electrode may comprise the photoactive composition and a second material. The second material, in some embodiments, may form a core and the photoactive composition may substantially cover the core. In other embodiments, the photoactive composition may be formed on only a portion of the second material (e.g., one side of the material). In some embodiments, the second material may be non-conductive (e.g.,) inorganic substrates, (e.g., quartz, glass, etc.) and polymeric substrates (e.g., polyethylene terephthalate, polyethylene naphthalate, polycarbonate, polystyrene, polypropylene, etc.) or conductive (e.g., metal, metal oxides, etc.). For example, the photoactive composition may be formed on the surface (e.g., as a film, as particles, as nanotubes) of a material (e.g., Ti, stainless steel, fluorine-doped SnO₂ coated glass (e.g., FTO), etc.). The photoactive composition may be formed on a second material using techniques known to those of ordinary skill in the art (e.g., solution techniques, sputtering, ultrasonic spray coating, chemical vapor deposition, etc.). The thickness of the photoactive composition may be at least about 10 nm, at least about 100 nm, at least about 1 μm, at least about 10 μm, at least about 100 μm, at least about 1 mm, or greater. Methods for determining the thickness of a material is described herein.

[0064] In some cases, a photoactive electrode may comprise a photoactive composition and a photosensitizing agent. For example, the photoactive composition may be associated with a photosensitizing agent (e.g., an organic dye). The photosensitizing agent may increase the conversion efficiency of the reactions. As an illustrative embodiment, electromagnetic radiation absorbed by the dye causes dye molecules to be transferred from a ground-state (Dye) to an excited state (Dye*) (e.g., see Equation 8). The excited state dyes may transfer electrons to the photoactive composition, resulting in the formation of a higher oxidation state dye (Dye⁺) and a reduced photoactive composition (e) (e.g., see Equation 9). The oxidized dye molecules may react with water, thereby resulting in the formation of oxygen at a photoactive electrode (e.g., see Equation 10). The electrons may be transferred from the photoactive composition to an electrode (e.g., through a circuit) where they may react with protons to produce hydrogen gas (e.g., see Equation 11), wherein the photoactive electrode is biased positively with respect to the electrode.



FIG. 6 shows an energy diagram for a photoelectrochemical device comprising a photoactive electrode, and an electrode, wherein the photoactive electrode comprises a photoactive composition and a dye, wherein the electrons and electrons holes are transferred as discussed above.

[0065] A wide variety of photosensitizing agents may be applied to and/or associated with a photoactive composition. In some cases, the photoactive electrode may consist essentially of the photoactive composition and the photosensitizing agent (for example, in instances where the photosensitizing agent is formed on a surface of a photoactive material). In other cases, the photoactive electrode may not consist essentially of the photoactive composition and the photosensitizing agent (for example, in instances where the photoactive composition is formed on a substrate (e.g., as a film) and the photosensitizing agent is formed (e.g., as a film) on the photoactive composition film). The photosensitizing agent may have a single, a narrow range (e.g., less than about 100 nm range), a plurality, and/or a wide range (e.g., greater than about 100 nm range) of light absorption peaks. In some cases, the absorption may occur at a wavelength(s) between about 300 nm and about 1000 nm. In some cases, the photosensitizing agent may comprise a metal complex dye, an organic dye, quantum dots, etc. Quantum dots will be known to those of ordinary skill in the art and may comprise ZnS, ZnSe, ZnTe, CdS, CdSe, CdTe, PbS, Bi₂S₃, HgS, HgSe, HgTe, MgTe, GaN, GaP, GaAs, GaSb, InN, InP, InAs, InSb, AlAs, AlP, AlSb, AlS, and the like, or combinations thereof (e.g., CdTe/CdSe(core/shell), CdSe/ZnTe(core/shell)). Quantum dots may allow for improved stability as compared to some metal or organic dyes, tailoring of the band gap of the quantum dots (e.g., by size quantification), and/or tailoring of the optical absorption of the quantum dots.

[0066] In some cases a metal complex dye may comprise a metal such as ruthenium, platinum, or any other suitable metal and an organic component (e.g., a ligand) such as biquinoline, bipyridyl, phenanthroline, thiocyanic acid or derivatives thereof. In some instances, an organic dye may comprise an organic component such as a porphyrin-based

system. The organic dyes may or might not comprise at least one metal (e.g., Zn, Mg, etc.). In some cases, the sensitizing agent may comprise a composition of the formula $\text{ML}_x(\text{L}')_y(\text{SCN})_z$ where M is a metal (e.g., Ru), L and L' may be the same or different and are polypyridyl ligands (e.g., 4,4''-(CO₂H)-2,2''-bipyridine), and x, y, and z can be the same or different and are any whole number 0, 1, 2, 3, etc.

[0067] In some cases, the photosensitizing agent comprises a porphyrin-based system, for example:

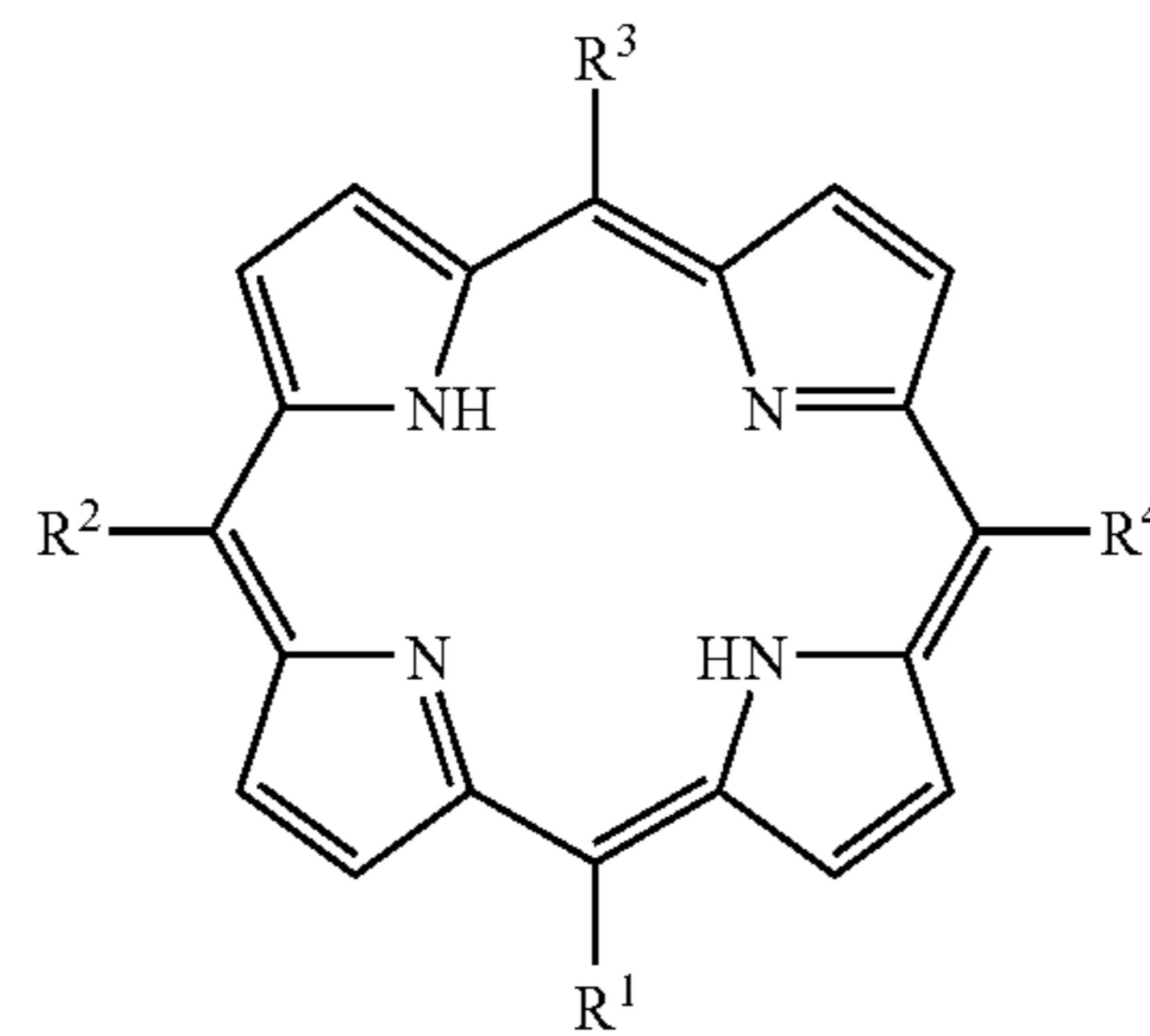

wherein R¹, R², R³, and R⁴ can be the same or different and are H, an alkyl, an alkenyl, an alkynyl, a heteroalkyl (e.g., CF₂CF₂CF₃), a heteroalkenyl, a heteroalkynyl, an aryl, or a heteroaryl, all optionally substituted, or are optionally absent (e.g., such that the compound is an anion, dianion, etc.). In some cases, additional carbons on the porphyrin may be optionally substituted. In some instances, the porphyrin may be an anion, dianion, etc. (e.g., such that at least one center nitrogen atom is an anion). In some embodiments, the porphyrin-based system may comprise a metal ion (e.g., such that the porphyrin is an anion or a dianion, etc., and the metal ion is coordinated in the center of the porphyrin by the nitrogen atoms). Non-limiting examples of such metals include Ru, Rh, Fe, Co, Mg, Al, Ag, Au, Zn, Sn, etc., as known to those of ordinary skill in the art. In a particular case, at least one of R¹ through R⁴ is an aryl, for example, —C₆H₅, —C₆F₅, —C₆H₄(COOH), —C₆H₄OH, —C₆H₄(CH₃), —C₆H₄(C(=O)OCH₃), (ortho, meta, or para)-C₆H₃X₂ where X is a halide (e.g., F, Cl, Br, I), etc. Non-limiting examples of porphyrins include, but are not limited to:

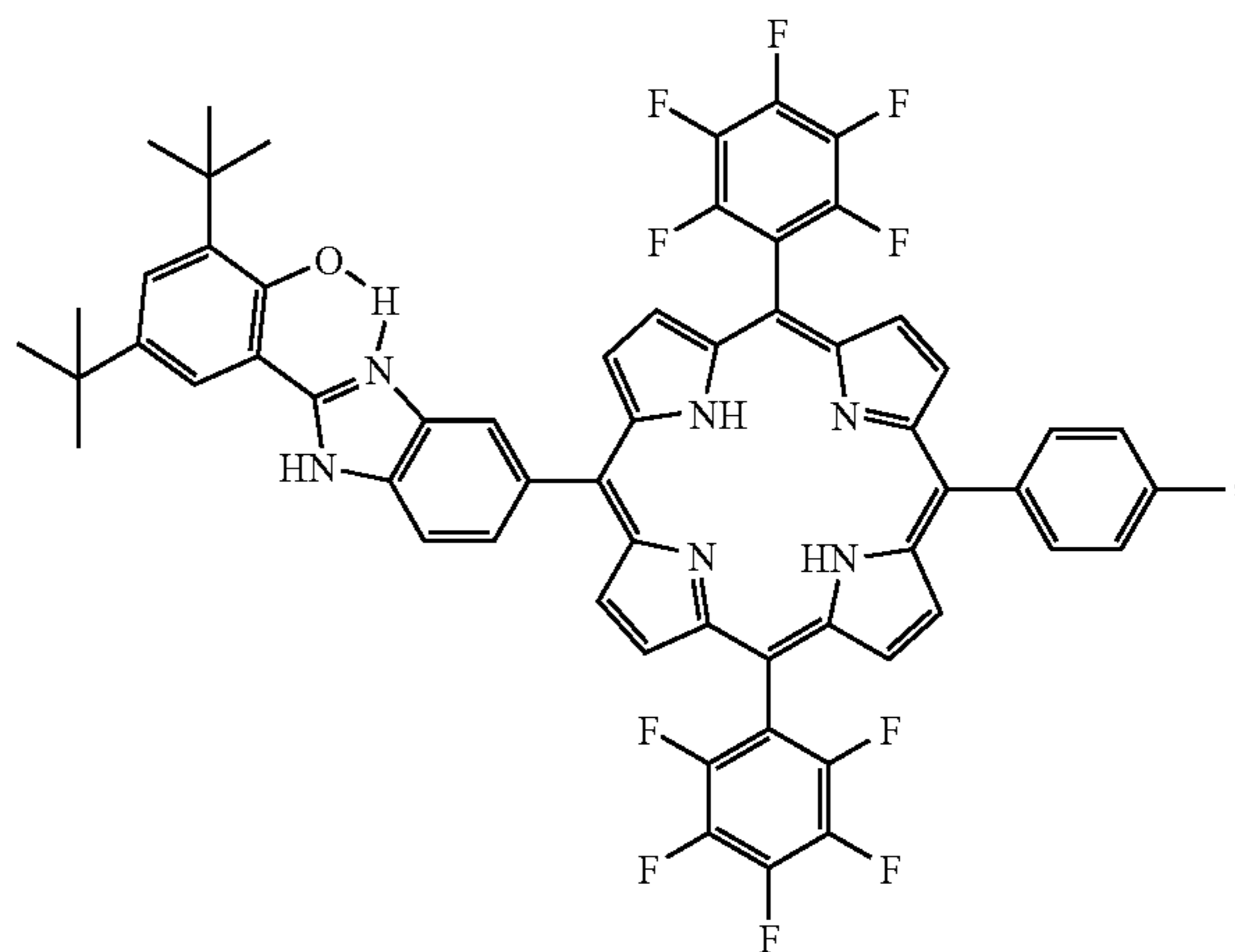

-continued

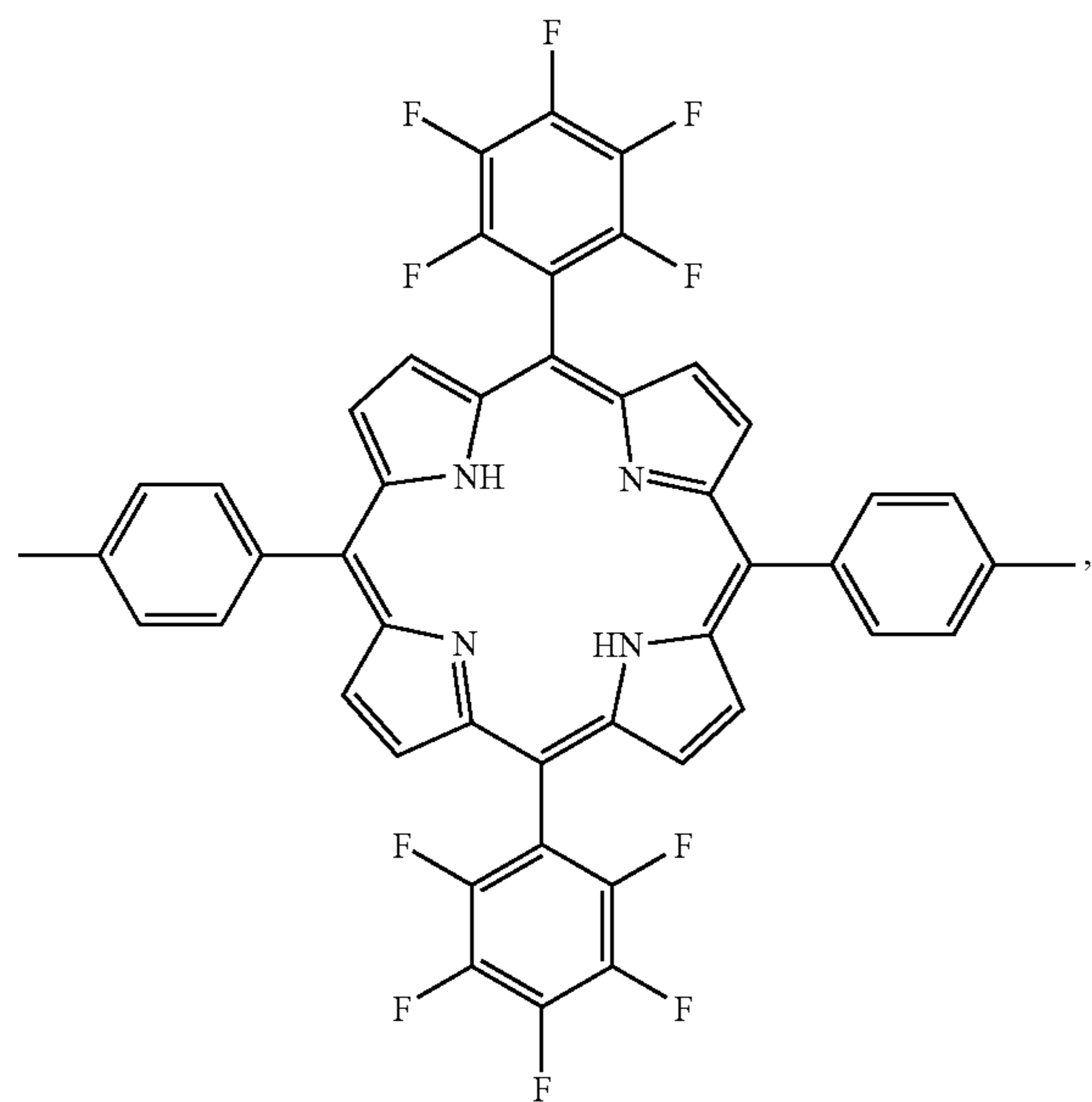

-continued

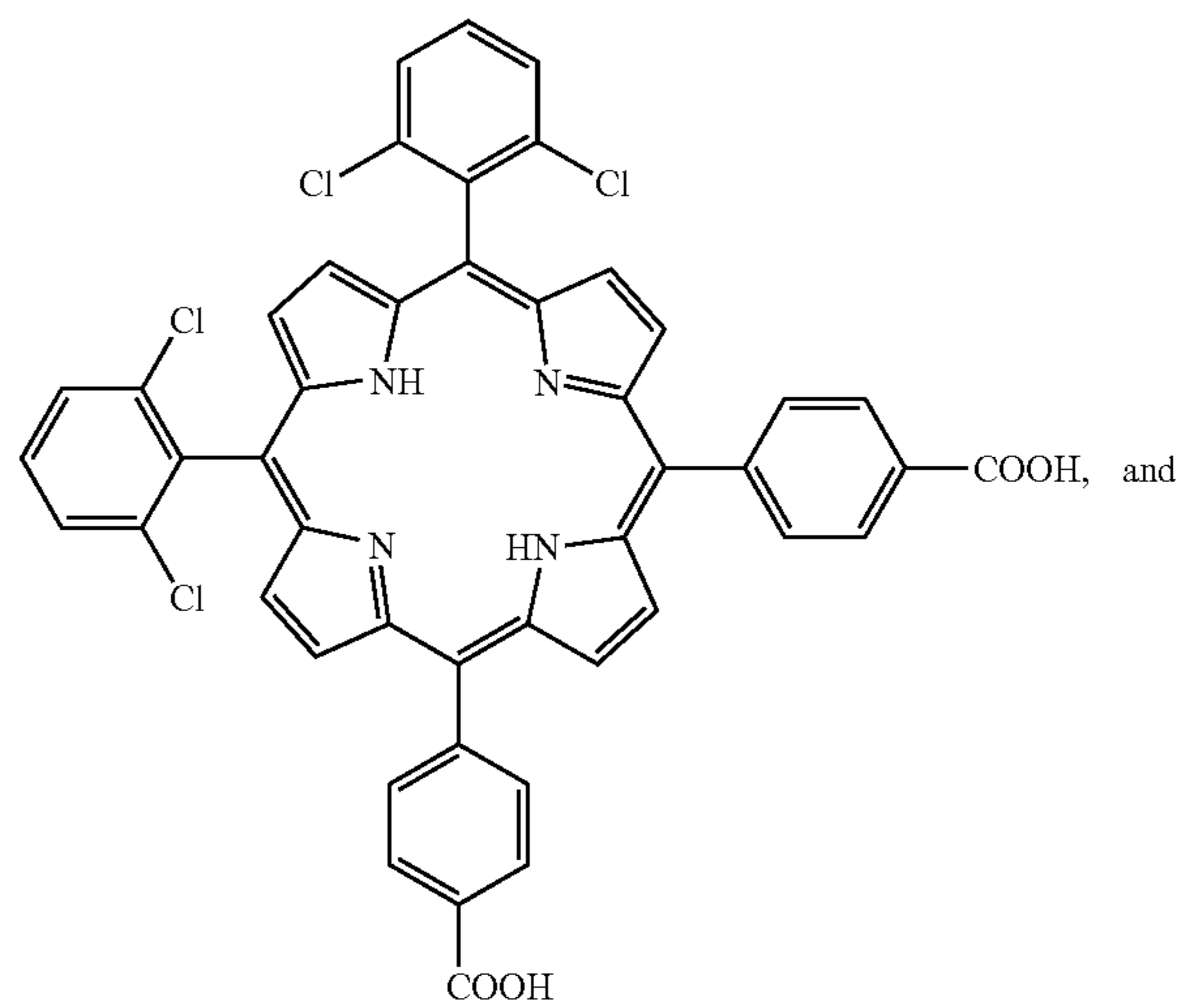
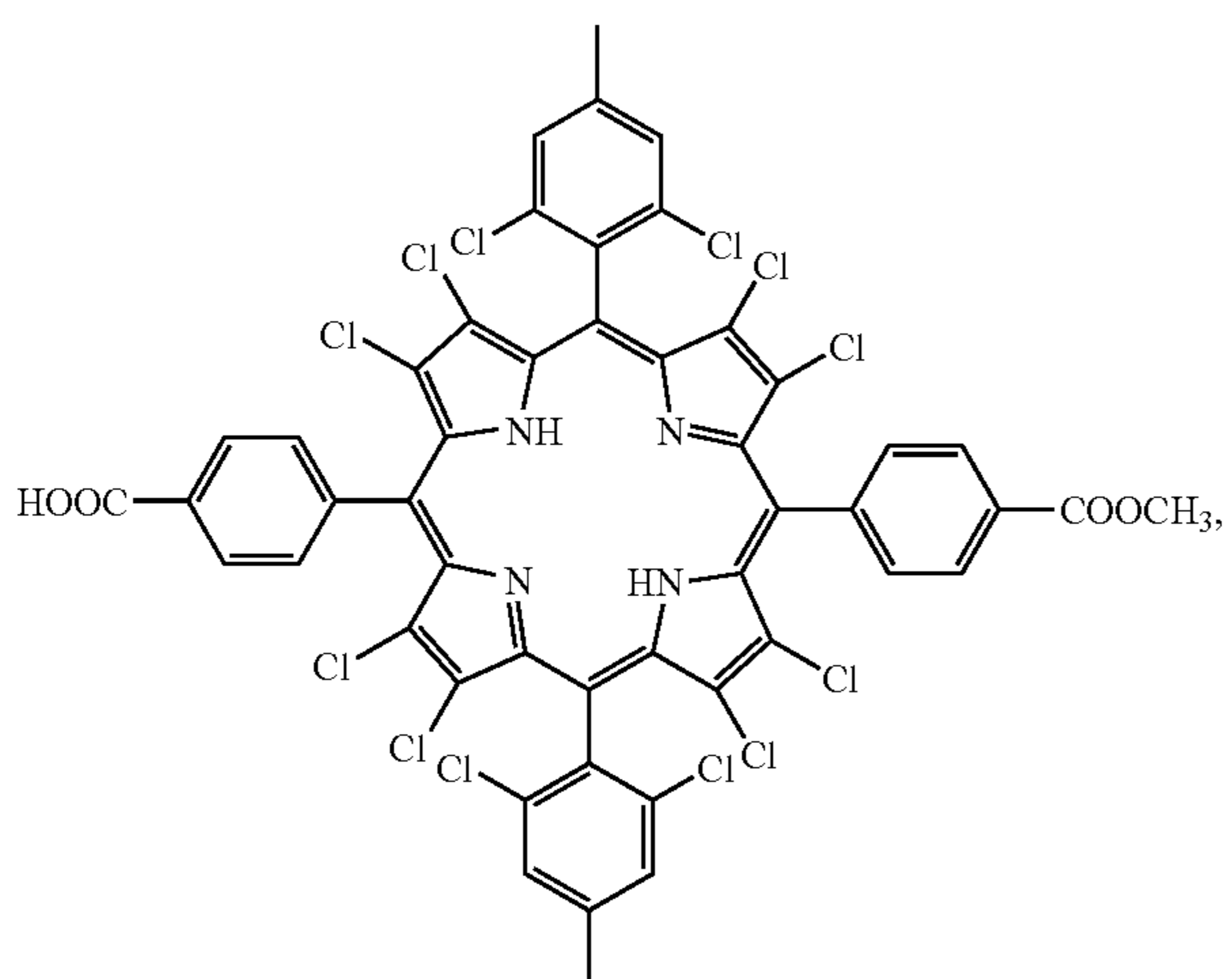
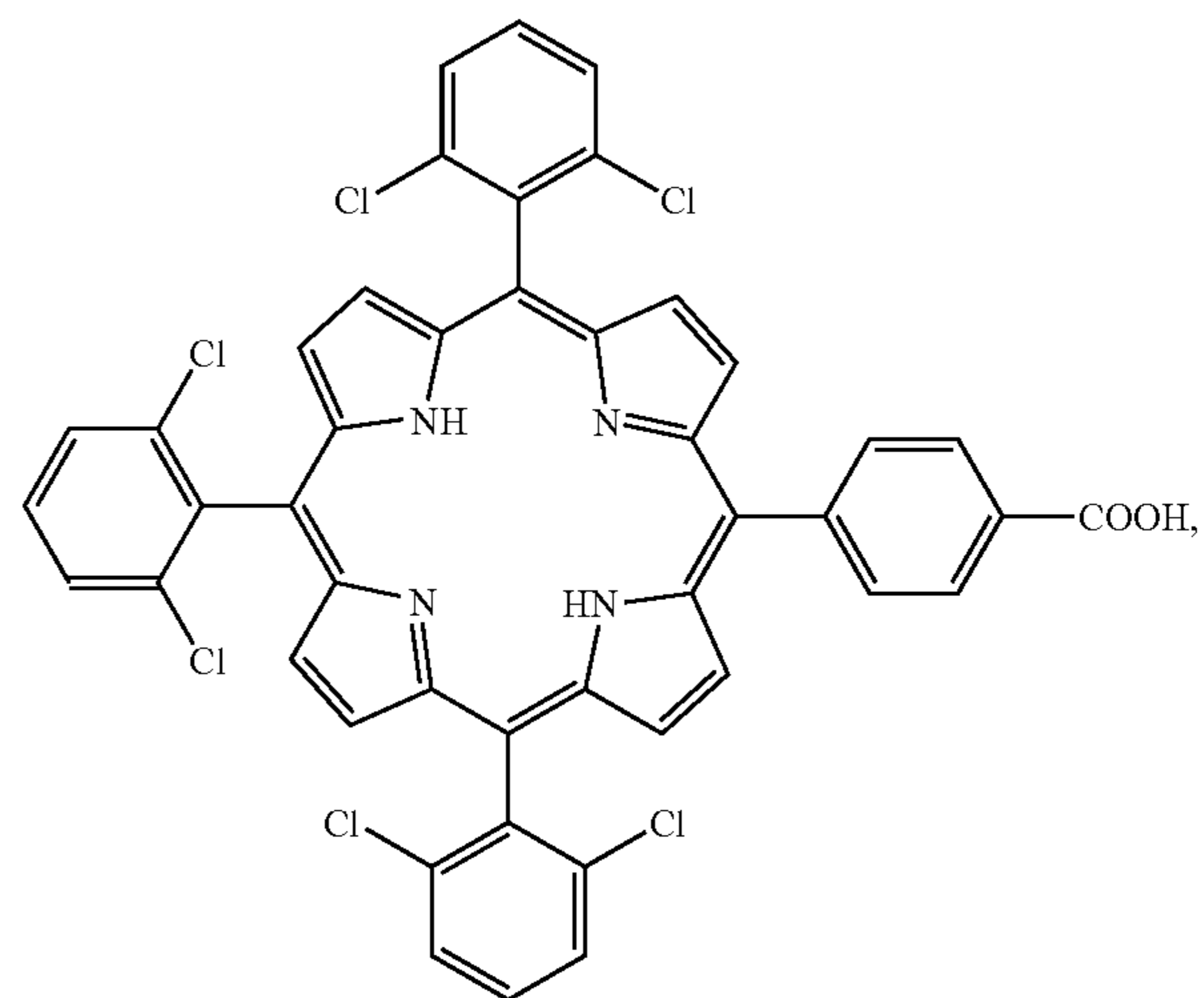
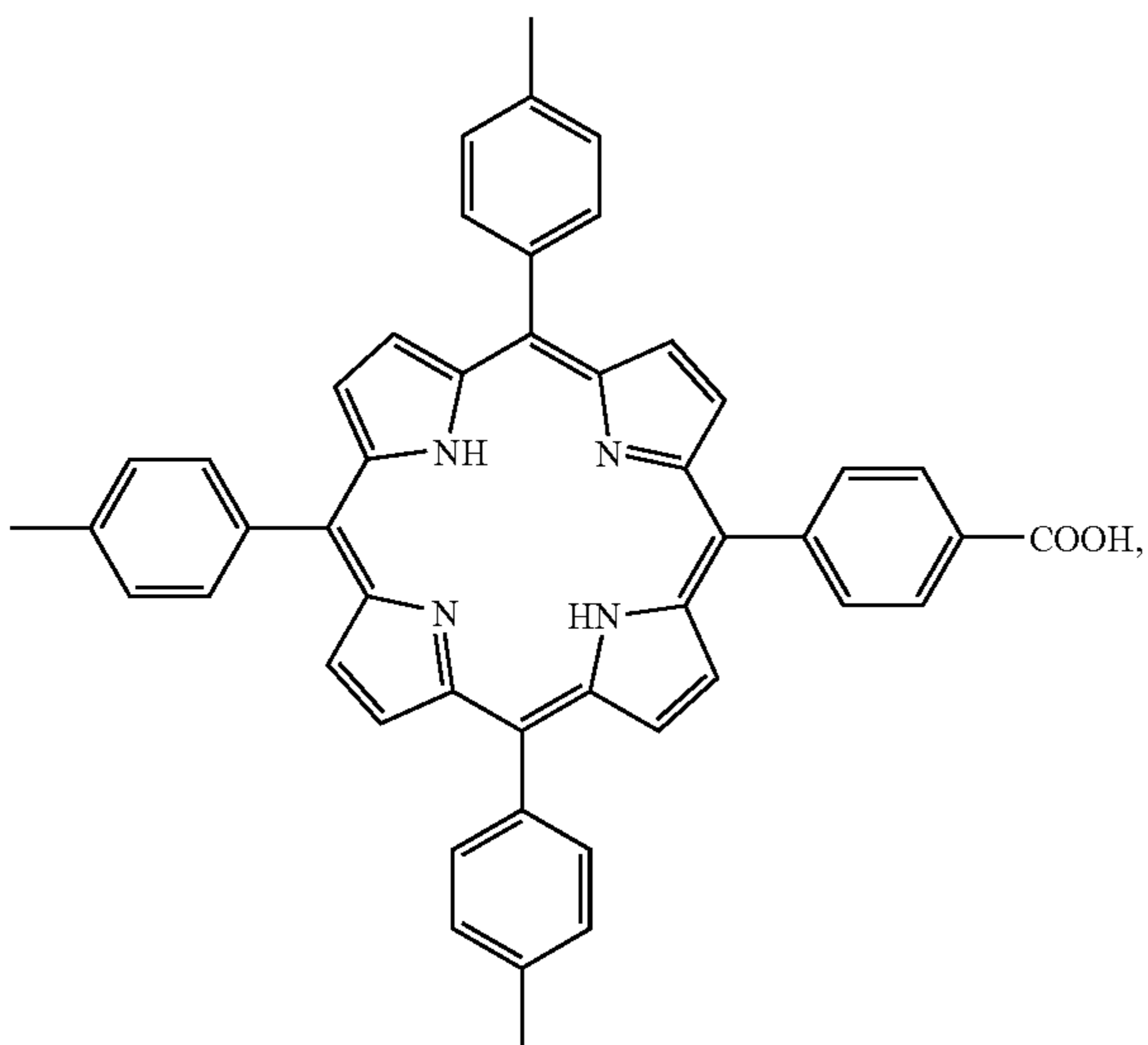
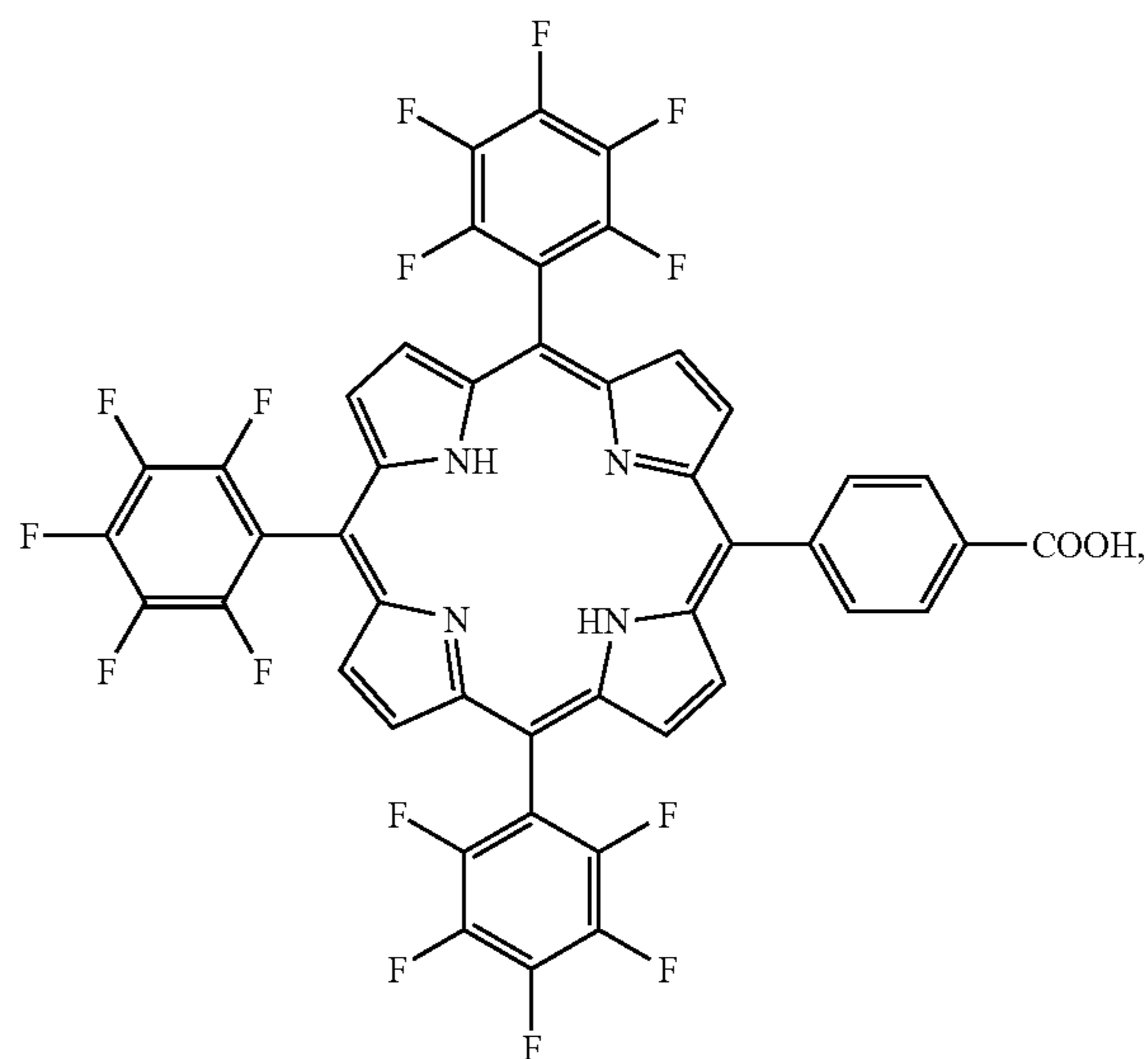

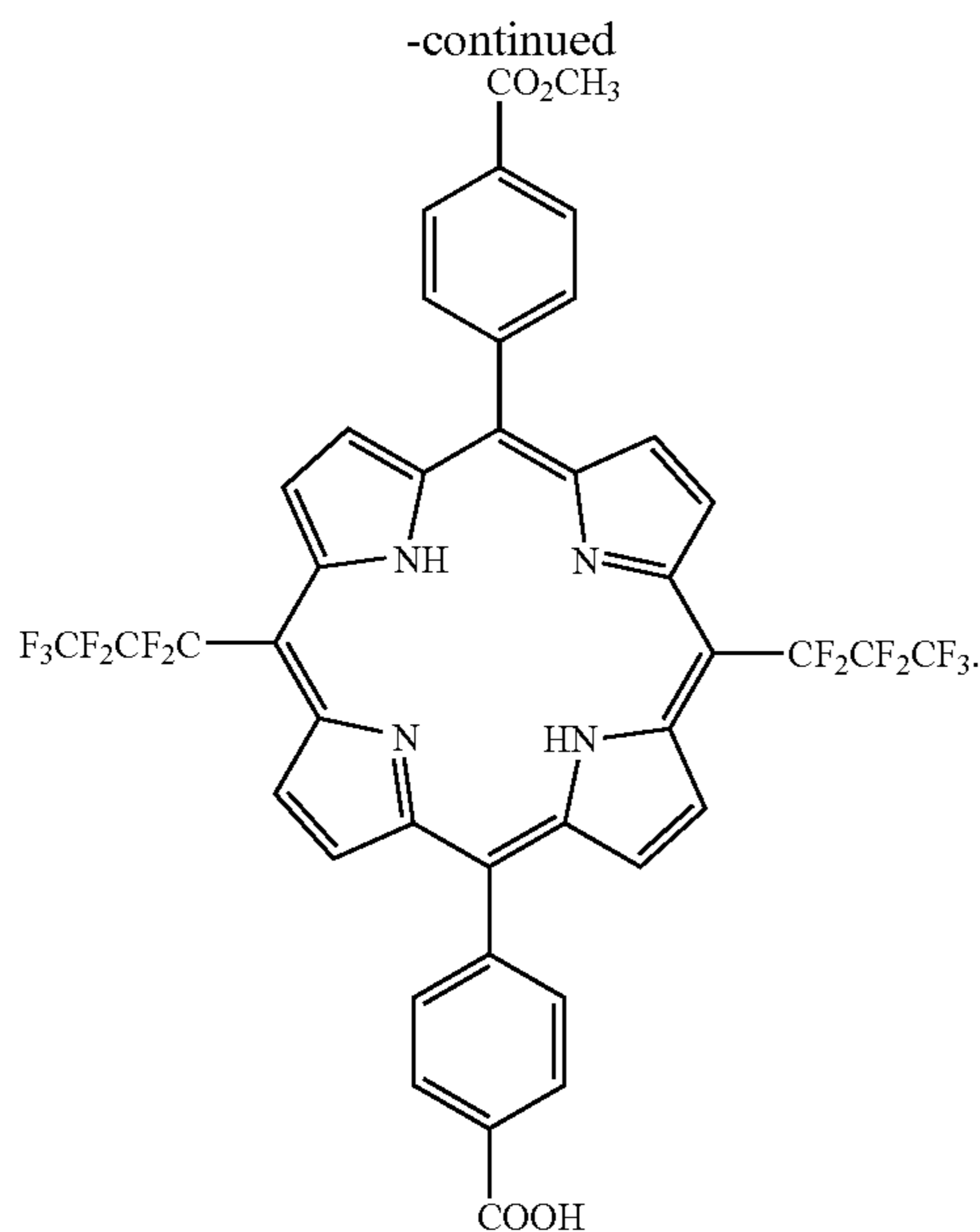

[0068] Additional suitable photosensitizing agents may include, for example, dyes that include functional groups, such as carboxyl and/or hydroxyl groups that can chelate to the nanoparticles, e.g., to Ti(IV) sites on a TiO₂ surface. Examples of suitable dyes include, but are not limited to, anthocyanins, phthalocyanines, merocyanines, cyanines, squarates, eosins, and metal-containing dyes. In some cases, a metal-containing dye may be a polypyridyl complex of ruthenium(II) (e.g., cis-bis(isothiocyanato)bis(2,2'-bipyridyl-4,4'-dicarboxylato)-ruthenium(II), tris(isothiocyanato)-ruthenium(II)-2,2':6',2''-terpyridine-4,4',4''-tricarboxylic acid, cis-bis(isothiocyanato)bis(2,2'-bipyridyl-4,4'-dicarboxylato)-ruthenium(II) bis-tetrabutylammonium, cis-bis(isocyanato)(2,2'-bipyridyl-4,4'-dicarboxylato)ruthenium(II), and tris(2,2'-bipyridyl-4,4'-dicarboxylato)ruthenium(II) dichloride).

[0069] The porosity of a photoactive electrode (or other component, for example, a photoanode) may be measured as a percentage or fraction of the void spaces in the photoactive electrode. The percent porosity of a photoactive electrode may be measured using techniques known to those of ordinary skill in the art, for example, using volume/density methods, water saturation methods, water evaporation methods, mercury intrusion porosimetry methods, and nitrogen gas adsorption methods. In some embodiments, the photoactive electrode may be at least about 10% porous, at least about 20% porous, at least about 30% porous, at least about 40% porous, at least about 50% porous, at least about 60% porous, or greater. The pores may be open pores (e.g., have at least one part of the pore open to an outer surface of the electrode and/or another pore) and/or closed pores (e.g., the pore does not comprise an opening to an outer surface of the electrode or another pore). In some cases, the pores of a photoactive electrode may consist essentially of open pores (e.g., the pores of the photoactive electrode are greater than at least 70%, greater than at least 80%, greater than at least 90%, greater than at least 95%, or greater, of the pores are open pores). In some cases, only a portion of the photoactive electrode may be substantially porous. For example, in some cases, only a

single surface of the photoactive electrode may be substantially porous. As another example, in some cases, the outer surface of the photoactive electrode may be substantially porous and the inner core of the photoactive electrode may be substantially non-porous. In a particular embodiment, the entire photoactive electrode is substantially porous.

[0070] In some embodiments, the photoactive electrode may have a high surface area (e.g., geometric or total surface area). In some cases, the surface area of the photoactive electrode may be greater than about 0.01 m²/g, greater than about 0.05 m²/g, greater than about 0.1 m²/g, greater than about 0.5 m²/g, greater than about 1 m²/g, greater than about m²/g, greater than about 10 m²/g, greater than about 20 m²/g, greater than about 30 m²/g, greater than about 50 m²/g, greater than about 100 m²/g, greater than about 150 m²/g, greater than about 200 m²/g, greater than about 250 m²/g, greater than about 300 m²/g, or the like. In other cases, the surface area of the photoactive electrode may be between about 0.01 m²/g and about 300 m²/g, between about 0.1 m²/g and about 300 m²/g, between about 10 m²/g and about 300 m²/g between about 0.1 m²/g and about 250 m²/g, between about 50 m²/g and about 250 m²/g, or the like. In some cases, the surface area of the photoactive electrode may be due to the photoactive electrode comprising a highly porous material. The surface area of a photoactive electrode may be measured using various techniques, for example, optical techniques (e.g., optical profiling, light scattering, etc.), electron beam techniques, mechanical techniques (e.g., atomic force microscopy, surface profiling, etc.), electrochemical techniques (e.g., cyclic voltammetry, etc.), etc., as known to those of ordinary skill in the art.

[0071] The photoactive electrode may be of any size or shape. Non-limiting examples of shapes include sheets, cubes, cylinders, hollow tubes, spheres, and the like. The photoactive electrode may be of any size, provided that at least a portion of the photoactive electrode may be immersed in the solution comprising the metal ionic species and the anionic species. The methods described herein are particularly amenable to forming the catalytic material on any shape and/or size of photoactive electrode. In some cases, the maximum dimension of the photoactive electrode in one dimension may be at least about 1 mm, at least about 1 cm, at least about 5 cm, at least about 10 cm, at least about 1 m, at least about 2 m, or greater. In some cases, the minimum dimension of the photoactive electrode in one dimension may be less than about 50 cm, less than about 10 cm, less than about 5 cm, less than about 1 cm, less than about 10 mm, less than about 1 mm, less than about 1 μm, less than about 100 nm, less than about 10 nm, less than about 1 nm, or less. Additionally, the photoactive electrode may comprise a means to connect the photoactive electrode to a power source and/or other electrical devices. In some cases, the photoactive electrode may be at least about 10%, at least about 30%, at least about 50%, at least about 60%, at least about 70%, at least about 80%, at least about 90%, at least about 95%, or at least about 100% immersed in the solution.

[0072] The photoactive electrode may or may not be substantially planar. For example, the photoactive electrode may comprise ripples, waves, dendrimers, spheres (e.g., nanospheres), rods (e.g., nanorods), a powder, a precipitate, a plurality of particles, and the like. In some embodiments, the surface of the photoactive electrode may be undulating, wherein the distance between the undulations and/or the

height of the undulations are on a scale of nanometers, micrometers, millimeters, centimeters, or the like. In some instances, the planarity of the photoactive electrode may be determined by determining the roughness of the photoactive electrode. As used herein, the term “roughness” refers to a measure of the texture of a surface (e.g., photoactive electrode), as will be known to those of ordinary skill in the art. The roughness of the photoactive electrode may be quantified, for example, by determining the vertical deviations of the surface of the photoactive electrode from planarity. Roughness may be measured using contact (e.g., dragging a measurement stylus across the surface such as a profilometer) or non-contact methods (e.g., interferometry, confocal microscopy, electrical capacitance, electron microscopy, etc.). In some cases, the surface roughness, R_a , may be determined, wherein R_a is the arithmetic average deviations of the surface valleys and peaks, expressed in micrometers. The R_a of a non-planar surface may be greater than about 0.1 μm , greater than about 1 μm , greater than about 5 μm , greater than about 10 μm , greater than about 50 μm , greater than about 100 μm , greater than about 500 μm , greater than about 1000 μm , or the like.

[0073] Without wishing to be bound by theory, the formation of a catalytic material on a photoactive electrode may proceed according to the following example. A photoactive electrode may be immersed in a solution comprising metal ionic species (M) with an oxidation state of (n) (e.g., M^n) and anionic species (e.g., A^{-y}). As voltage is applied to the photoactive electrode, metal ionic species near to the photoactive electrode may be oxidized to an oxidation state of (n+x) (e.g., $M^{(n+x)}$). The oxidized metal ionic species may interact with an anionic species near the electrode to form a substantially insoluble complex, thereby forming a catalytic material. In some cases, the catalytic material may be in electrical communication with the photoactive electrode. A non-limiting example of this process is depicted in FIG. 7. FIG. 7A shows a single metal ionic species 40 with an oxidation state of (n) in solution 42. Metal ionic species 44 may be near photoactive electrode 46, as depicted in FIG. 7B. As shown in FIG. 7C, metal ionic species may be oxidized to an oxidized metal ionic species 48 with an oxidation state of (n+x) and (x) electrons 50 may be transferred to photoactive electrode 52 or to another species near or associated with the metal ionic species and/or the photoactive electrode. FIG. 7D depicts a single anionic species 54 nearing oxidized metal ionic species 56. In some instances, as depicted in FIG. 7E, anionic species 58 and oxidized metal ionic species 60 may associate with photoactive electrode 62 to form a catalytic material. In some instances, the oxidized metal ionic species and the anionic species may interact and form a complex (e.g., a salt) before associating with the electrode. In other instances, the metal ionic species and anionic species may associate with each other prior to oxidation of the metal ionic species. In other instances, the oxidized metal ionic species and/or anionic species may associate directly with the photoactive electrode and/or with another species already associated with the photoactive electrode. In these instances, the metal ionic species and/or anionic species may associate with the photoactive electrode (either directly, or via formation of a complex) to form the catalytic material (e.g., a composition associated with the photoactive electrode).

[0074] In some embodiments, a photoanode may be formed by immersing a photoactive electrode associated with a material comprising a metal ionic species (e.g., a layer of a metal

such as metallic cobalt associated with a photoactive electrode) in a solution comprising ionic species (e.g., phosphate). The metal ionic species (e.g., in an oxidation state of M^n) may be oxidized and/or dissociated from the photoactive electrode into solution. The metal ionic species that are oxidized and/or dissociated from the photoactive electrode may interact with anionic species and/or other species, and may re-associate with the photoactive electrode, thereby re-forming a catalytic material.

[0075] As noted above, one aspect of the invention involves an efficient and robust catalytic material (for electrolysis of water and/or other electrochemical reactions) that is primarily photoactive electrode-associated, rather than functioning largely as a homogeneous solution-based catalytic materials. Such a catalytic material “associated with” a photoactive electrode will now be described with reference to a metal ionic species and/or anionic species which can define a catalytic material of the invention. In some cases, the anionic species and the metal ionic species may interact with each other prior to, simultaneously to, and/or after the association of the species with the photoactive electrode, and result in a catalytic material with a high degree of solid content resident on, or otherwise immobilized with respect to, the photoactive electrode. In this arrangement, the catalytic material can be solid including various degrees of electrolyte or solution (e.g., the material can be hydrated with various amounts of water), and/or other species, fillers, or the like, but a unifying feature among such catalytic material associated with photoactive electrodes is that they can be observed, visually or through other techniques described more fully below, as largely resident on or immobilized with respect to the photoactive electrode, either in electrolyte solution or after removal of the photoactive electrode from solution.

[0076] In some cases, the catalytic material may associate with the photoactive electrode via formation of a bond, such as an ionic bond, a covalent bond (e.g., carbon-carbon, carbon-oxygen, oxygen-silicon, sulfur-sulfur, phosphorus-nitrogen, carbon-nitrogen, metal-oxygen, or other covalent bonds), a hydrogen bond (e.g., between hydroxyl, amine, carboxyl, thiol, and/or similar functional groups), a dative bond (e.g., complexation or chelation between metal ions and monodentate or multidentate ligands), Van der Waals interactions, and the like. “Association” of the composition (e.g., catalytic material) with the photoactive electrode would be understood by those of ordinary skill in the art based on this description. In some embodiments, the interaction between a metal ionic species and an anionic species may comprise an ionic interaction, wherein the metal ionic species is directly bound to other species and the anionic species is a counterion not directly bound to the metal ionic species. In a specific embodiment, an anionic species and a metal ionic species form an ionic bond and the complex formed is a salt.

[0077] A catalytic material associated with a photoactive electrode may be most often arranged with respect to the photoactive electrode so that it is in sufficient electrical communication with the photoactive electrode to carry out purposes of the invention as described herein. “Electrical communication,” as used herein, is given its ordinary meaning as would be understood by those of ordinary skill in the art whereby electrons can flow between the photoactive electrode and the catalytic material in a facile enough manner for the photoanode to operate as described herein. That is, charge may be transferred between the photoactive electrode and the catalytic material (e.g., the metal ionic species and/or anionic

species present in the catalytic material). In one arrangement, the composition is in direct contact with the photoactive electrode. In another arrangement, a material may be present between the composition and the photoactive electrode (e.g., a photosensitizing agent, an insulator, a conducting material, a semiconducting material, etc.).

[0078] In some cases, the composition may be in “direct electrical communication” with the photoactive electrode. “Direct electrical communication,” as used herein, is given its ordinary meaning as defined above with respect to electrical communication, but in this instance, the photoactive electrode and the composition are in direct contact with one another (e.g., as opposed to through a secondary material, through use of circuitry, etc.). In some embodiments, the composition and the photoactive electrode may be integrally connected. The term “integrally connected,” when referring to two or more objects, means objects that do not become separated from each other during the course of normal use, e.g., separation requires at least the use of tools, and/or by causing damage to at least one of the components, for example, by breaking, peeling, dissolving, etc. A composition may be considered to be in direct electrical communication with a photoactive composition during operation of a photoanode even in instances where a portion of the composition may dissociate from the photoactive composition when taking part in a dynamic equilibrium.

[0079] In some embodiments, a composition (e.g., catalytic material) may be in “indirect electrical communication” with a photoactive electrode. That is, a material and/or circuitry may be interposed between the composition and the photoactive electrode. In some cases, the material may be a “hole-tunneling barrier.” That is, a material through which electron-holes generated in the photoactive electrode may tunnel through to access the composition (e.g., catalytic material). The hole-tunneling barrier may aid in protecting the photoactive electrode from corrosion. In some instances, the material may be a conducting material, thereby allowing electrons to flow between the photoactive electrode and the composition. The electrons may be used for the production of oxygen gas from water via the composition. Without wishing to be bound by theory, a material disposed between the composition and the photoactive electrode may act as a membrane and may allow for the transmission of electron holes generated at the photoactive electrode to the composition. This arrangement may be advantageous in devices where the separation of oxygen gas and hydrogen gas formed from the oxidation of water is important. The presence of the material may prevent oxygen gas formed where the composition is present from transversing the device and entering the area where hydrogen gas is produced. In some cases, the material may be selected such that no oxygen gas is produced in the material (e.g., in instances where the overpotential for production of oxygen gas is high).

[0080] In instances where the photoanode comprises a catalytic material and a photoactive electrode (e.g., comprising a photoactive composition and a photosensitizing agent), the catalytic material, the photoactive composition and the photosensitizing agent may be in electrical communication with one another. In some cases, the photoactive composition and the photosensitizing agent and/or the photosensitizing agent and the catalytic material may be in direct electrical communication with one another and/or integrally connected. For example, in some cases, a photoanode may comprise a photoactive composition in direct electrical communication with

a photosensitizing agent, wherein the photosensitizing agent is in direct electrical communication with a catalytic material (e.g., the photoactive composition comprises a coating of a photosensitizing agent followed by a coating of catalytic material).

[0081] It should be understood that while much of the discussion herein focuses on a photoanode comprising a catalytic material associated with a photoactive electrode (e.g., the photoactive electrode and the catalytic material are in direct electrical communication), this is by no means limiting, and the photoanode may comprise one or more materials between the photoactive electrode and the catalytic material (e.g., such that the photoactive electrode and the catalytic material are in indirect electrical communication).

[0082] One aspect of the invention involves the development of a regenerative catalytic photoanode. As used herein, a “regenerative photoanode” refers to a photoanode which is capable of being compositionally regenerated as it is used in a catalytic process, and/or over the course of a change between catalytic use settings. Thus, a regenerative photoanode of the invention is one that includes one or more species associated with the photoanode (e.g., adsorbed on the photoanode) which, under certain conditions, dissociate from the photoanode, and then a significant portion or substantially all of those species re-associate with the photoanode at a later point in the photoanode’s life or use cycle. For example, at least a portion of the catalytic material may dissociate from the photoanode and become solvated or suspended in a fluid to which the photoanode is exposed, and then become re-associated (e.g., adsorbed) at the photoanode. The dissociation/re-association may take place as a part of the catalytic process itself, as catalytic species cycle between various states (e.g., oxidation states), in which they are more or less soluble in the fluid. This phenomenon during use, for example, nearly or essentially steady-state use of the electrode, can be defined as a dynamic equilibrium. “Dynamic equilibrium,” as used herein, refers to an equilibrium comprising metal ionic species and anionic species, wherein at least a portion of the metal ionic species are cyclically oxidized and reduced (as discussed elsewhere herein). Regeneration over the course of a change between catalytic use settings can be defined by a dynamic equilibrium which experiences a significant delay in its cyclical nature.

[0083] In some embodiments, at least a portion of the catalytic material may dissociate from the photoanode and become solvated or suspended in the fluid (or solution and/or to other medium) as a result of a significant reaction setting change, and then become re-associated at a later stage. A significant reaction setting change, in this context, can be a significant change in potential applied to the electrode, significantly different current density at the photoanode, significantly different properties of a fluid to which the photoanode is exposed (or removal and/or changing of the fluid), or the like. In one embodiment, the photoanode is exposed to catalytic conditions under which the catalytic material catalyzes a reaction, then the circuit of which the photoanode is a part is changed so that the catalytic reaction is significantly slowed or even essentially stopped (e.g., the process is turned off), and then the system can be returned to the original catalytic conditions (or similar conditions that promote the catalysis), and at least a portion, or essentially all of the catalytic material, can re-associate with the photoanode. Re-association of some or essentially all of the catalytic material with the photoanode can occur during use and/or upon change in condi-

tions as noted above, and/or can occur upon exposure of the catalytic material, the electrode, or both to a regenerative stimulus, such as a regenerative electrical potential, current, temperature, electromagnetic radiation, or the like. In some cases, the regeneration may comprise a dynamic equilibrium mechanism involving oxidation and/or reduction processes, as described elsewhere herein.

[0084] Regenerative photoanodes of the invention can exhibit disassociation and re-association of catalytic species at various levels. In one set of embodiments, at least about 0.1% by weight of catalytic material associated with the photoanode disassociates as described herein, and in other embodiments as much as about 0.25%, about 0.5%, about 0.6%, about 0.8%, about 1.0%, about 1.25%, about 1.5%, about 1.75%, about 2.0%, about 2.5%, about 3%, about 4%, about 5%, or more of the catalytic material disassociates, and some or all re-associates as discussed. In various embodiments, of the amount of material that disassociates, at least about 50%, at least about 60%, at least about 70%, at least about 80%, at least about 85%, at least about 90%, at least about 95%, at least about 97%, at least about 98%, at least about 99%, or essentially all material re-associates. Those of ordinary skill in the art will understand the meaning of disassociation and re-association of material in this regard, and will know of techniques for measuring these factors (for example, scanning electron microscopy and/or elemental analyses of the electrode, chemical analysis of the fluid, photoanode performance, or any combination). Further, those of ordinary skill in the art will quickly be able to select catalytic materials which meet these parameters with knowledge of solubilities and/or catalytic reaction screening, or combinations. As a specific example, in some cases, during use of a catalytic material comprising cobalt ions and anionic species comprising phosphorus, at least a portion of the cobalt ions and the anionic species comprising phosphorus periodically associate and dissociate from the electrode.

[0085] Catalytic materials of the invention may also exhibit significant robustness through varying levels of use in a way that is a significant improvement over the general state of the art. Through a mechanism that may be related to regeneration as described herein, systems and/or photoanodes employing catalytic materials of the invention may be operated at varying rates of applied energy, as would result from being driven by power sources that vary (e.g., wind power, solar power which generally varies over the daily cycle and weather patterns, etc.), and/or go through full on/off energy cycles. In particular, systems and/or photoanodes of the invention may be cycled such that potential and/or current supplied to the system and/or photoanode is reduced by at least about 20%, at least about 40%, at least about 60%, at least about 80%, at least about 90%, at least about 95%, or essentially 100% from peak use current, for at least from a period of about 2 minutes, at least about 5 minutes, at least about 10 minutes, at least about 20 minutes, at least about 30 minutes, at least about 1 hour, at least about 2 hours, at least about 3 hours, at least about 5 hours, at least about 8 hours, at least about 12 hours, at least about 24 hours or greater, and cycled at least about five times, at least about 10 times, at least about 20 times, at least about 50 times, or more, while overall performance (e.g., overpotential at a selected current density, production of oxygen gas, production of water, etc.) of the system and/or photoanode, decreases by no more than about 20%, no more than about 10%, no more than about 8%, no more than about 6%, no more than about 4%, no more than about 3%, no more than

about 2%, no more than about 1%, or the like. In some cases, the performance measurement may be taken at about the same period of time after reapplication of the voltage/current to the photoanode/system (e.g., after voltage/current has been reapplied to the photoanode/system for about 1 minute, about 5 minutes, about 10 minutes, about 30 minutes, about 60 minutes, etc.).

[0086] It should be understood, however, that not every metal ionic species and/or anionic species which exhibits a change in oxidation state can dissociate and re-associate with a photoactive electrode. In some cases, only a small portion (e.g., less than about 20%, less than about 15%, less than about 10%, less than about 5%, less than about 2%, less than about 1%, or less) of the oxidized/reduced metal ionic species may dissociate/associate with the photoactive electrode during operation or between uses.

[0087] Those of ordinary skill in the art also will quickly recognize the significance of the contribution of this aspect (e.g., regeneration mechanism) of the invention to the field. It is known that degradation of catalytic materials and photoanodes can be problematic during their use, or especially when they are shut off between uses, especially in the case of metal organic, inorganic, and/or organometallic catalytic materials exposed to conditions previously assumed necessary for standard catalytic processes, and/or conditions described in accordance with catalysis according to the present invention (e.g., metal oxides and/or hydroxides or other catalytic materials used in processes at high pH). Without wishing to be bound by any theory, the inventors believe their development of regenerative photoanodes relates to selection of species with high enough stability under catalytic conditions described herein, and/or combination of this feature with the process of some amount of catalytic material loss from the photoanode followed by re-association of the material with the photoanode, which is believed to involve a material cleansing process. The regeneration mechanism may also inhibit unwanted coating or other accumulation of auxiliary species, which do not play a role in the catalytic process and which may inhibit catalysis and/or other performance characteristics.

[0088] Regenerative photoanodes of the invention also exhibit strong and surprising performance associated with their regenerative properties. Thus, in various embodiments, a regenerative photoanode of the invention not only has good long-term robustness, but exhibits surprisingly good stability even upon significant variations in its use. Significant use variations can involve the photoanode and its corresponding catalysis system being switched from on to off states, or other significant changes in use profile. This can be particularly important where the photoanode is driven by solar power, where variation in the sun intensity can vary dramatically. In such a situation, a photoanode of the invention may be operating at essentially full capacity at times, and be switched off at times (e.g., where an electrical circuit in which the photoanode exists is in an "open" position). The photoanode of the invention exhibits robustness such that, when it is operated at or close to its highest capacity for catalysis, i.e., at its highest rate of catalysis, and then switched off ("open circuit"), and this is repeated at least ten times, the photoanode exhibits less than about 10%, less than about 5%, less than about 4%, less than about 3%, less than about 2%, less than about 1%, less than about 0.5%, or less than about 0.25% loss in performance. In this case, performance can be measured as current density at a particular set overpotential, with all other condi-

tions being essentially identical between all tests. Of course, the photoanode need not necessarily be switched between essentially full capacity and off in this way, but a photoanode of the invention, when treated in this way, will exhibit a level of robustness.

[0089] In some cases, the photoanode may be capable of regeneration, as described herein, in a closed system. That is, the photoanode may be capable of regeneration without removal and/or addition of any material(s) that aids and/or assists in the regeneration of the photoanode. Alternatively, removal of and/or addition of such material in only small amounts in various embodiments, such as, for example, no more than about 1% by weight, or no more than about 2%, 4%, 6%, 10%, or more, by weight of such material. For example, in instances where the photoanode comprises a regenerative catalytic material, the catalytic material may be capable of regeneration without addition of any of the components comprised in the catalytic material (e.g., metal ionic species and/or anionic species where the catalytic material is composed of these materials) in such a closed system, or addition of one or such components in amounts no more than those described above in various embodiments. It should be understood, however, that a “closed system” as used herein does not exclude addition or removal of species that do not define, or can not react within the system to define, the catalytic material. For example, additional fuel and/or water may be provided to such a system.

[0090] In some embodiments, a dynamic equilibrium may comprise at least a portion of the metal ionic species being cyclically oxidized and reduced, wherein the metal ionic species are thereby associated and disassociated, respectively, from the photoactive electrode. An example of a dynamic equilibrium (or regenerative mechanism) which can, but need not necessarily, take place in accordance with the invention is depicted in FIG. 8. FIG. 8A depicts a photoanode comprising photoactive electrode **80** and catalytic material **82** comprising metal ionic species **84** and anionic species **86**. The dynamic equilibrium is depicted in FIGS. 8B-8C. FIG. 8B shows the same photoanode, wherein a portion of metal ionic species **88** and anionic species **90** have disassociated from photoactive electrode **92**. FIG. 8C shows the same photoanode at some point later in time where a portion of the metal ionic species and anionic species (e.g., **94**) which disassociated from the photoactive electrode have re-associated with photoactive electrode **96**. Additionally, different metal ionic species and anionic species (e.g., **98**) may have disassociated from the photoactive electrode. Metal ionic species and anionic species can repeatedly disassociate and associate with the photoactive electrode. For example, the same metal ionic species and anionic species may disassociate and associate with the photoactive electrode. In other instances, the metal ionic species and/or anionic species may only disassociate and/or associate with the photoactive electrode once. A single metal ionic species may associate with the photoactive electrode simultaneously as a second single metal ionic species disassociates from the photoanode. The number of single metal ionic species and/or single anionic species that may disassociate and/or associate simultaneously and/or within the lifetime of the photoanode has no numerical limit.

[0091] It should be understood that a solution in which metal ionic species and/or anionic species may be solubilized may be transiently present (e.g., the solution might not necessarily be in contact with the photoactive electrode during the entire operation and/or formation of the photoanode). For

example, in instances where water is provided to the photoanode in a gaseous state, in some embodiments, the solution may be comprised of transiently formed aqueous molecules and/or droplets on the surface of the photoanode and/or electrolyte. In other instances, where the electrolyte is a solid, the solution may be present in addition to the electrolyte (e.g., as water droplets on the surface of the photoanode and/or solid electrolyte) or in combination with the fuel (e.g., water). The photoanode may be operated with a combination of solid electrolyte/gaseous fuel, fluid electrolyte/gaseous fuel, solid electrolyte/fluid fuel, fluid electrolyte/fluid fuel, or any combination thereof.

[0092] In some embodiments, during the dynamic equilibrium, at least a portion of the metal ionic species are cyclically oxidized and reduced. That is, the oxidation state of at least a portion of the metal ionic species involved in the dynamic equilibrium is repeatedly changed during the dynamic equilibrium. A change in the oxidation state of a metal ionic species may also correlate to the association or dissociation of the metal ionic species with the photoactive electrode.

[0093] In some embodiments, the metal ionic species in solution may have an oxidation state of (n), while the metal ionic species associated with the photoactive electrode may have an oxidation state of (n+x), wherein x is any whole number. The change in oxidation state may facilitate the association of the metal ionic species on the photoactive electrode. It may also facilitate the oxidation of water to form oxygen gas or other electrochemical reactions. The cyclically oxidized and reduced oxidation states for a single metal ionic species in dynamic equilibrium may be expressed according to Equation 12:



where M is a metal ionic species, n is the oxidation state of the metal ionic species, x is the change in the oxidation state, and $x(e^-)$ is the number of electrons, where x may be any whole number. In some cases, the metal ionic species may be further oxidized and/or reduced, (e.g., the metal ionic species may access oxidation states of $M^{(n+1)}$, $M^{(n+2)}$, etc.)

[0094] An illustrative example of changes in oxidation state that may occur for a single metal ionic species during a dynamic equilibrium is shown in FIG. 9. FIG. 9A depicts a photoactive electrode **100** and a single metal ionic species **102** in oxidation state of (n), (e.g., M^n). The metal ionic species **102** may be oxidized to a metal ionic species **104** with an oxidation state of (n+1) (e.g., $M^{(n+1)}$) and/or associate with the photoactive electrode **106**, as shown in FIG. 9B. At this point, the metal ionic species (e.g., $M^{(n+1)}$) may disassociate from the photoactive electrode **106** or may undergo a further change in oxidation state. In some cases, as shown in FIG. 9C, the metal ionic species may be further oxidized to a single metal ionic species **108** with an oxidation state of (n+2), (e.g., $M^{(n+2)}$) and may remain associated with the photoactive electrode (or may disassociate from the photoactive electrode). At this point, metal ionic species **108** (e.g., $M^{(n+2)}$) may accept electrons (e.g., from water or another reaction component) and may be reduced to form metal ionic species with a reduced oxidation state of (n) or (n+1) (e.g., $M^{(n+1)}$, **106** or M^n , **102**). In other cases, the metal ionic species **106** (e.g., $M^{(n+1)}$) may be reduced and reform metal ionic species in oxidation state (n) (e.g., M^n , **102**). The metal ionic species in oxidation state (n) may remain associated with the photoactive electrode or may disassociate from the photoactive electrode (e.g., dissociate into solution).

[0095] Those of ordinary skill in the art will be able to use suitable screening tests to determine whether a metal ionic species and/or anionic species are in dynamic equilibrium and/or whether a photoactive electrode is regenerative. For example, in some cases, the dynamic equilibrium may be determined using radioisotopes of the metal ionic species and/or anionic species. In such cases, a photoanode comprising a photoactive electrode and a catalytic material comprising radioisotopes may be prepared. The photoanode may be placed in an electrolyte which comprises non-radioactive ionic species. The catalytic material may dissociate from the photoactive electrode and therefore, the solution may comprise radioactive isotopes of the anionic species and/or metal ionic species. This may be determined by analyzing an aliquot of the electrolyte for the radioisotopes. Upon application of the voltage to the photoactive electrode, in instances where the metal ionic species and anionic species are in dynamic equilibrium, the radioisotopes of the metal ionic species may re-associate with the photoactive electrode. Aliquots of the electrolyte may be analyzed to determine the amount of radioisotope present in the electrolyte at various time points after application of the voltage. If the metal ionic species and anionic species are in dynamic equilibrium, the percentage of radioisotopes in solution may decrease with time as the radioisotopes re-associate with the photoactive electrode. This screening technique may be used both to determine how a catalytic material may be functioning, and to select materials which can be used as catalytic materials suitable for the invention.

[0096] Further techniques useful for selecting suitable catalytic material follow. Without wishing to be bound by theory, the solubility of a material comprising anionic species and oxidized metal ionic species may influence the association of the metal ionic species and/or anionic species with the photoactive electrode. For example, if a material formed by (c) number of anionic species and (b) number of oxidized metal ionic species is substantially insoluble in the solution, the material may be influenced to associate with the photoactive electrode. This non-limiting example may be expressed according to Equation 13:

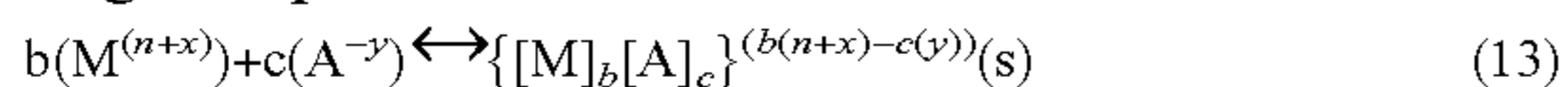

where $M^{(n+x)}$ is the oxidized metal ionic species, A^{-y} is the anionic species, and $\{[M]_b[A]_c\}^{(b(n+x)-c(y))}$ is at least a portion of catalytic material formed, where b and c are the number of metal ionic species and anionic species, respectively. Therefore, the equilibrium may be driven towards the formation of the catalytic material by the presence of an increased amount of anionic species. In some cases, the solution surrounding the photoactive electrode may comprise an excess of anionic species, as described herein, to drive the equilibrium towards the formation of the catalytic material associated with the photoactive electrode. It should be understood, however, that the catalytic material does not necessarily consist essentially of a material defined by the formula $\{[M]_b[A]_c\}^{(b(n+x)-c(y))}$, as, in most cases, additional components can be present in the catalytic material (e.g., a second type of anionic species). However, the guidelines described herein (e.g., regarding K_{sp}) provide information to select complimentary anionic species and metal ionic species that may aid in the formation and/or stabilization of the catalytic material. In some cases, the catalytic material may comprise at least one bond between a metal ionic species and an anionic species (e.g., a bond between a cobalt ion and an anionic species comprising phosphorus).

[0097] Selection of metal ionic species and anionic species for use in the invention will now be described in greater detail. It is to be understood that any of a wide variety of such species meeting the criteria described herein can be used and, so long as they participate in catalytic reactions described herein, they need not necessarily behave, in terms of their oxidation/reduction reactions, cyclical association/disassociation from the photoactive electrode etc., in the manner described in the application. But in many cases, metal ionic and anionic species selected as described herein, do behave according to one or more of the oxidations/reduction and solubility theories described herein. In some embodiments, the metal ionic species (M^n) and the anionic species (A^{-y}) may be selected such that they exhibit the following properties. In most cases, the metal ionic species and the anionic species are soluble in an aqueous solution. In addition, the metal ionic species may be provided in an oxidized form, for example with an oxidation state of (n), where (n) is one, two, three, or greater, i.e., in some cases, the metal ionic species have access to an oxidation state greater than (n), for example, (n+1) and/or (n+2).

[0098] The solubility product constant, K_{sp} , as will be known to those of ordinary skill in the art, is a simplified equilibrium constant defined for the equilibria between a composition comprising the species and their respective ions in solution and may be defined according to Equation 15, based on the equilibrium shown in Equation 14.

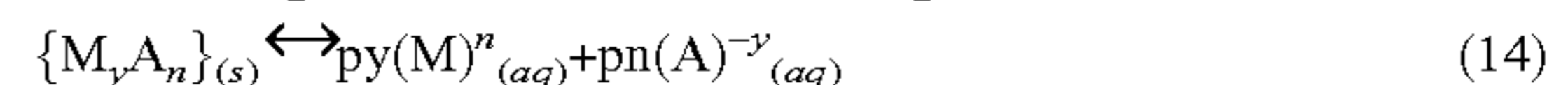

In Equations 14 and 15, M is the positively charged metal ionic species and A is the anionic species and y is not equal to n. In embodiments where y is equal to n, the equation may be simplified as shown in Equation 16.



The solid complex M_yA_n may disassociate into solubilized metal ionic species and anionic species. Equation 15 shows the solubility product constant expression. As will be known to those of ordinary skill in the art, the solubility product constant value may change depending on the temperature of the aqueous solution. Therefore, when choosing metal ionic species and anionic species for the formation of a photoanode, the solubility product constant should be determined at the temperature at which the photoanode is to be formed and/or operated in. In addition, the solubility of a solid complex may change depending on the pH. This effect should be taken into account when applying the solubility product constant to the selection of a metal ionic species and an anionic species.

[0099] In many cases, the metal ionic species and anionic species are selected together, for example, such that a composition comprising the metal ionic species with an oxidation state of (n) and the anionic species is soluble in an aqueous solution, the composition having a solubility product constant which is greater than the solubility product constant of a composition comprising the metal ionic species with an oxidation state of (n+x) and the anionic species. That is, the composition comprising the metal ionic species with an oxidation state of (n) and the anionic species may have a K_{sp} value substantially greater than the K_{sp} for the composition comprising the metal ionic species with an oxidation state of (n+x) and the anionic species. For example, the metal ionic species and anionic species may be selected such that the K_{sp} value of a composition comprising the anionic species and the

metal ionic species with an oxidation state of (n) (e.g., M^n) is greater than the K_{sp} value of the composition comprising the anionic species and the metal ionic species with an oxidation state of (n+x) (e.g., $M^{(n+x)}$) by a factor of at least about 10, at least about 10^2 , at least about 10^3 , at least about 10^4 , at least about 10^5 , at least about 10^6 , at least about 10^8 , at least about 10^{10} , at least about 10^{15} , at least about 10^{20} , at least about 10^{30} , at least about 10^{40} , at least about 10^{50} , and the like. Where these K_{sp} values are realized, a catalytic material may be more likely to serve as a photoanode or photoactive electrode-associated material.

[0100] In some instances, a catalytic material, such as a composition comprising a metal ionic species with an oxidation state of (n+x) and an anionic species may have a K_{sp} between about 10^{-3} and about 10^{-50} . In some cases, the solubility constant of this composition may be between about 10^{-4} and about 10^{-50} , between about 10^{-5} and about 10^{-40} , between about 10^{-6} and about 10^{-30} , between about 10^{-3} and about 10^{-30} , between about 10^{-3} and about 10^{-20} , and the like. In some cases, the solubility constant may be less than about 10^{-3} , less than about 10^{-4} , less than about 10^{-6} , less than about 10^{-8} , less than about 10^{-10} , less than about 10^{-15} , less than about 10^{-20} , less than about 10^{-25} , less than about 10^{-30} , less than about 10^{-40} , less than about 10^{-50} , and the like. In some cases, the composition comprising metal ionic species with an oxidation state of (n) and the anionic species may have a solubility product constant greater than about 10^{-3} , greater than about 10^{-4} , greater than about 10^{-5} , greater than about 10^{-6} , greater than about 10^{-8} , greater than about 10^{-12} , greater than about 10^{-15} , greater than about 10^{-18} , greater than about 10^{-20} , and the like. In a particular embodiment, the composition comprising metal ionic species and the anionic species may be selected such that the composition comprising the metal ionic species with an oxidation state of (n) and the anionic species have a K_{sp} value between about 10^{-3} and about 10^{-10} and the composition comprising the metal ionic species with an oxidation state of (n+x) and the anionic species have a K_{sp} value less than 10^{-10} . Non-limiting examples of metal ionic species and anionic species that can be soluble in an aqueous solution and have a K_{sp} value in a suitable range includes Co(II)/HPO_4^{-2} , $\text{Co(II)/H}_2\text{BO}_3^-$, $\text{Co(II)/HAsO}_4^{-2}$, Fe(II)/CO_3^{-2} , Mn(II)/CO_3^{-2} , and $\text{Ni(II)/H}_2\text{BO}_3^-$. In some cases, these combinations may additionally comprise at least a second type of anionic species, for example, oxide and/or hydroxide ions. The composition that forms on the photoactive electrode may comprise the metal ionic species and anionic species selected, as well as additional components (e.g., oxygen, water, hydroxide, counter cations, counter anions, etc.).

[0101] As noted, a photoanode can be formed by deposition of a catalytic material from solution. Whether the photoanode has been properly formed, with proper association of the catalytic material with the photoactive electrode, may be important to monitor, both for selecting proper metal ionic species and/or anionic species and, of course, determining whether an appropriate photoanode has been formed. The photoanode may be determined to have been formed using various procedures. In some instances, the formation of a catalytic material on the photoactive electrode may be observed. The formation of the material may be observed by a human eye, or with use of magnifying devices such as a microscope or via other instrumentation. In one case, application of a voltage to the photoanode, in conjunction with an appropriate counter electrode (or photocathode) and other

components (e.g., circuitry, power source, electrolyte) may be carried out to determine whether the system produces oxygen gas at the photoanode when the photoanode is exposed to water.

[0102] In some cases, the onset potential (and/or minimum overpotential) that is required by the photoanode to produce oxygen gas may be different than the onset potential (and/or overpotential) required by the photoactive electrode alone. The term, “onset potential,” as used herein, refers to the potential at which the photocurrent of the photoanode becomes positive as the potential applied to the photoanode is swept from negative to positive values. In some cases, the onset potential required for the photoanode is less positive than the onset potential required for the photoactive electrode alone (i.e., the onset potential is less positive for the photoanode that includes both the photoactive electrode and catalytic material, than for the photoactive electrode alone). In some embodiments, the onset potential of a photoanode comprising a photoactive electrode and a catalytic material is at least about 100 mV, at least about 200 mV, at least about 250 mV, at least about 300 mV, at least about 350 mV, at least about 400 mV, at least about 450 mV, at least about 500 mV, or more, less positive than the onset potential of the photoactive electrode alone. Or, in some cases, the onset potential is about 100 mV, about 200 mV, about 250 mV, about 300 mV, about 350 mV, about 400 mV, about 450 mV, about 500 mV less positive.

[0103] In some cases, the incident photon-to-current conversion efficiency (or IPCE, also known as energy quantum efficiency) that is required by the photoanode to produce oxygen gas may be different than the IPCE required by the photoactive electrode alone. The term “incident photon-to-current conversion efficiency,” as used herein, refers to a measure of the photon to electron conversion efficiency at a specific wavelength. As will be known to those of ordinary skill in the art, IPCE may be determined from measuring the monochromatic light power density, and may be calculated as a function of short circuit current density, incident light power density, and wavelength. In some cases, the IPCE for the photoanode is greater than the IPCE for the photoactive electrode alone. In some embodiments, the IPCE of a photoanode comprising a photoactive electrode and a catalytic material is about 1%, about 2%, about 5%, about 10%, about 20%, about 25%, about 30%, about 40%, about 50%, about 75%, about 100%, or more, greater than the IPCE of the photoactive electrode alone. In some cases, the IPCE is measured with solar simulated light (e.g., AM-1.5 illumination).

[0104] In some cases, a device (e.g., photoelectrochemical cell) comprising the photoanode may be characterized by its overall efficiency for conversion of solar energy to chemical energy. In such embodiments, a photoelectrochemical cell may be illuminated with light (e.g. solar simulated AM 1.5 radiation) to generate a photocurrent. The overall energy conversion efficiency of the device may be determined by Equation 17:

$$\eta(\%)=100(E-V_{bias})(i_t)/(P_{hv}A) \quad (17)$$

wherein η is the overall energy conversion efficiency of the device, E is the Nernstian value for electrolysis of the solution redox species (e.g., conversion of water to hydrogen and oxygen gas), V_{bias} is the voltage across the cell, i_t is the total current flowing in the device, P_{hv} is the power of the incident light radiation, and A is irradiated surface area. V_{bias} is generally defined to be negative if the cell can simultaneously

produce electrical power and stored chemical energy, and is generally defined to be positive if an additional power input is needed for the cell to perform the desired electrolysis reaction. In some embodiments, the overall energy conversion efficiency may be less than about 0.1%, less than about 1%, less than about 2%, less than about 5%, less than about 10%, less than about 15%, less than about 18%, less than about 20%, less than about 25%, less than about 30%, less than about 50%, or the like. In some cases, the overall energy conversion efficiency is about 0.1%, about 0.5%, about 1%, about 5%, about 10%, about 15%, about 18%, about 20%, about 25%, about 30%, about 35%, about 40%, about 50%, or the like, or between about 0.1% and about 30%, between about 1% and about 30%, between about 10% and about 50%, between about 10% and about 30%, or any range therein. Those of ordinary skill in the art will be aware of techniques for determining the overall energy conversion efficiency, for example, see Parkinson et al., *Acc. Chem. Res.* 1984, 17, 431-437.

[0105] The catalytic material (and/or the photoanode comprising the catalytic material) may also be characterized in terms of performance. One way of doing this, among many, is to compare the current density of the photoanode versus the photoactive electrode alone. Typical photoactive electrodes are described more fully below and can include titanium dioxide (e.g., TiO₂), and the like. The photoactive electrode may be able to function, itself, as a photoanode in water electrolysis, and may have been used in the past to do so. So, the current density during catalytic water electrolysis (where the photoanode catalytically produces oxygen gas from water), using the photoactive electrode, as compared to essentially identical conditions (with the same counter electrode or photocathode, same electrolyte, same external circuit, same water source, etc.), using the photoanode including both photoactive electrode and catalytic material, can be compared. In most cases, the current density of the photoanode is greater than the current density of the photoactive electrode alone, where each is tested independently under essentially identical conditions. For example, the current density of the photoanode may exceed the current density of the photoactive electrode by a factor of at least about 10, about 100, about 1000, about 10⁴, about 10⁵, about 10⁶, about 10⁸, about 10¹⁰, and the like. In a particular case, the difference in the current density is at least about 10⁵. In some embodiments, the current density of the photoanode may exceed the current density of the photoactive electrode by a factor between about 10⁴ and about 10¹⁰, between about 10⁵ and about 10⁹, or between about 10⁴ and about 10⁸. The current density may either be the geometric current density or the total current density, as described herein.

[0106] This characteristic, namely, significantly increased catalytic activity of the photoanode (comprising a photoactive electrode and catalytic material associated with the photoactive electrode) as compared to the photoactive electrode alone, may be used to monitor formation of a catalytic photoanode. That is, the formation of the catalytic material on the photoactive electrode may be observed by monitoring the current density over a period of time. The current density, in most cases, increases during application of a voltage to the photoactive electrode. In some instances, the current density may reach a plateau after a period of time (e.g., about 2 hours, about 4 hours, about 6 hours, about 8 hours, about 10 hours, about 12 hours, about 24 hours, and the like).

[0107] Metal ionic species useful as one portion of a catalytic material of the invention may be any metal ion selected according to the guidelines described herein. In most embodiments, the metal ionic species have access to oxidation states of at least (n) and (n+x). In some cases, the metal ionic species have access to oxidation states of (n), (n+1) and (n+2). (n) may be any whole number, and includes, but is not limited to, 0, 1, 2, 3, 4, 5, 6, 7, 8, and the like. In some cases, (n) is not zero. In particular embodiments, (n) is 1, 2, 3 or 4. (x) may be any whole number and includes, but is not limited to 0, 1, 2, 3, 4, and the like. In particular embodiments, (x) is 1, 2, or 3. Non-limiting examples of metal ionic species include Sc, Ti, V, Cr, Mn, Fe, Co, Ni, Cu, Y, Zr, Nb, Mo, Tc, Rh, Ru, Ag, Cd, Pt, Pd, Ir, Hf, Ta, W, Re, Os, Hg, and the like. In some cases, the metal ionic species may be a lanthanide or actinide (e.g., Ce, Pr, Nd, Sm, Eu, Gd, Tb, Dy, Ho, Er, Tm, Yb, Lu, Th, Pa, U, etc.). In a particular embodiment, the metal ionic species comprises cobalt ions, which may be provided as a catalytic material in the form of Co(II), Co(III) or the like. In some embodiments, the metal ionic species is not Mn. The metal ionic species may be provided (e.g., to the solution) as a metal compound, wherein the metal compound comprises metal ionic species and counter anions. For example, the metal compound may be an oxide, a nitrate, a hydroxide, a carbonate, a phosphite, a phosphate, a sulphite, a sulphate, a triflate, and the like.

[0108] An anionic species selected for use as a catalytic material of the invention may be any anionic species that is able to interact with the metal ionic species as described herein and to meet threshold catalytic requirements as described. In some cases, the anionic compound may be able to accept and/or donate hydrogen ions, for example, H₂PO₄⁻ or HPO₄⁻². Non-limiting examples of anionic species include forms of phosphate (H₃PO₄ or HPO₄⁻², H₂PO₄⁻² or PO₄⁻³), forms of sulphate (H₂SO₄ or HSO₄⁻, SO₄⁻²), forms of carbonate (H₂CO₃ or HCO₃⁻, CO₃⁻²), forms of arsenate (H₃AsO₄ or HAsO₄⁻², H₂AsO₄⁻² or AsO₄⁻³), forms of phosphite (H₃PO₃ or HPO₃⁻², H₂PO₃⁻² or PO₃⁻³), forms of sulphite (H₂SO₃ or HSO₃⁻, SO₃⁻²), forms of silicate, forms of borate (e.g., H₃BO₃, H₂BO₃⁻, HBO₃⁻², etc.), forms of nitrates, forms of nitrites, and the like.

[0109] In some cases, the anionic species may be a form of phosphonate. A phosphonate is a compound comprising the structure PO(OR¹)(OR²)(R³) wherein R¹, R², and R³ can be the same or different and are H, an alkyl, an alkenyl, an alkynyl, a heteroalkyl, a heteroalkenyl, a heteroalkynyl, an aryl, or a heteroaryl, all optionally substituted, or are optionally absent (e.g., such that the compound is an anion, dianion, etc.). In a particular embodiment, R¹, R², and R³ can be the same or different and are H, alkyl, or aryl, all optionally substituted. A non-limiting example of a phosphonate is a form of PO(OH)₂R¹ (e.g., PO₂(OH)(R¹)⁻, PO₃(R¹)⁻²), wherein R¹ is as defined above (e.g., alkyl such as methyl, ethyl, propyl, etc.; aryl such as phenol, etc.). In a particular embodiment, the phosphonate may be a form of methyl phosphonate (PO(OH)₂Me), or phenyl phosphonate (PO(OH)₂Ph). Other non-limiting examples of phosphorus-containing anionic species include forms of phosphinites (e.g., P(OR¹)R²R³) and phosphonites (e.g., P(OR¹)(OR²)R³) wherein R¹, R², and R³ are as described above. In other cases, the anionic species may comprise one any form of the following compounds: R¹SO₂(OR²), SO(OR¹)(OR²), CO(OR¹)(OR²), PO(OR¹)(OR²), AsO(OR¹)(OR²)(R³), wherein R¹, R², and R³ are as described above. With respect to the anionic species

discussed above, those of ordinary skill in the art will be able to determine appropriate substituents for the anionic species. The substituents may be chosen to tune the properties of the catalytic material and reactions associated with the catalytic material. For example, the substituent may be selected to alter the solubility constant of a composition comprising the anionic species and the metal ionic species.

[0110] In some embodiments, the anionic species may be good proton-accepting species. As used herein, a “good proton-accepting species” is a species which acts as a good base at a specified pH level. For example, a species may be a good proton-accepting species at a first pH and a poor proton-accepting species at a second pH. Those of ordinary skill in the art can identify a good base in this context. In some cases, a good base may be a compound in which the pK_a of the conjugate acid is greater than the pK_a of the proton donor in solution. As a specific example, SO_4^{-2} may be a good proton-accepting species at about pH 2.0 and a poor proton-accepting species at about pH 7.0. A species may act as a good base around the pK_a value of the conjugate acid. For example, the conjugate acid of HPO_4^{-2} is $H_2PO_4^-$, which has a pK_a value of about 7.2. Therefore, HPO_4^{-2} may act as a good base around pH 7.2. In some cases, a species may act as a good base in solutions with a pH level at least about 4 pH units, about 3 pH units, about 2 pH units, or about 1 pH unit, above and/or below the pK_a value of the conjugate acid. Those of ordinary skill in the art will be able to determine at which pH levels an anionic species is a good proton-accepting species.

[0111] The anionic species may be provided as a compound comprising the anionic species and a counter cation. The counter cation may be any cationic species, for example, a metal ion (e.g., K^+ , Na^+ , Li^+ , Mg^{+2} , Ca^{+2} , Sr^{+2}), NR_4^+ (e.g., NH_4^+), H^+ , and the like. In a specific embodiment, the compound employed may be K_2HPO_4 .

[0112] The catalytic material may comprise the metal ionic species and anionic species in a variety of ratios (amounts relative to each other). In some cases, the catalytic material comprises the metal ionic species and the anionic species in a ratio of less than about 20:1, less than about 15:1, less than about 10:1, less than about 7:1, less than about 6:1, less than about 5:1, less than about 4:1, less than about 3:1, less than about 2:1, greater than about 1:1, greater than about 1:2, greater than about 1:3, greater than about 1:4, greater than about 1:5, greater than about 1:10, and the like. In some cases, the catalytic material may comprise additional components, such as counter cations and/or counter anions from the metallic compound and/or anionic compound provided to the solution. For example, in some instances, the catalytic material may comprise the metal ionic species, the anionic species, and a counter cation and/or anion in a ratio of about 2:1:1, about 3:1:1, about 3:2:1, about 2:2:1, about 2:1:2, about 1:1:1, and the like. The ratio of the species in the catalytic material will depend on the species selected. In some instances, a counter cation may be present in a very small amount and serve as a dopant to, for example, to improve the conductivity or other properties of the material. In these instances, the ratio may be about X:1:0.1, about X:1:0.005, about X:1:0.001, about X:1:0.0005, etc., where X is 1, 1.5, 2, 2.5, 3, and the like. In some instances, the catalytic material may additionally comprise at least one of water, oxygen gas, hydrogen gas, oxygen ions (e.g., O^{-2}), peroxide, hydrogen ion (e.g., H^+), and/or the like.

[0113] In some embodiments, a catalytic material of the invention may comprise more than one type of metal ionic

species and/or anionic species (e.g., at least about 2 types, at least about 3 types, at least about 4 types, at least about 5 types, or more, of metal ionic species and/or anionic species). For example, more than one type of metal ionic species and/or anionic species may be provided to the solution in which the photoactive electrode is immersed. In such instances, the catalytic material may comprise more than one type of metal ionic species and/or anionic species. Without wishing to be bound by theory, the presence of more than one type of metal ionic species and/or anionic species may allow for the properties of the photoanode to be tuned, such that the performance of the photoanode may be altered by using combinations of species in different ratios. In a particular embodiment, a first type of metal ionic species (e.g., Co(II)) and second type of metal ionic species (e.g., Ni(II)) may be provided in the solution in which the photoactive electrode is immersed, such that the catalytic material comprises the first type of metal ionic species and the second type of metal ionic species (e.g., Co(II) and Ni(II)). Where a first and second type of metal ionic species are used together, each can be selected from among metal ionic species described as suitable for use herein.

[0114] Where both first type and a second type of metal ionic and/or anionic species are used, both the first and second species need not both be catalytically active, or if both are catalytically active they need not be active to the same level or degree. The ratio of the first type of metal ionic and/or anionic species to the second type of metal ionic and/or anionic species may be varied and may be about 1:1, about 1:2, about 1:3, about 1:4, about 1:5, about 1:6, about 1:7, about 1:8, about 1:9, about 1:10, about 1:20, or greater. In some instances, the second type of species may be present in a very small amount and serve as a dopant to, for example, to improve the conductivity or other properties of the material. In these instances, the ratio of the first type of species to the second type of metal ionic species may be about 1:0.1, about 1:0.005, about 1:0.001, about 1:0.0005, etc. In some embodiments, a catalytic material comprising more than one metal ionic species and/or anionic species may be formed by first forming a catalytic material comprising a first type of metal ionic species and a first type of anionic species, followed by exposing the photoanode comprising the catalytic material to a solution comprising a second type of metal ionic species and/or second type of anionic species and applying a voltage to the photoanode (e.g., via an external power source or by exposing the photoanode to electromagnetic radiation). This may cause the second type of metal ionic species and/or second type of anionic species to be comprised in the catalytic material. In other embodiments, the catalytic material may be formed by exposing a photoactive electrode to a solution comprising the components (e.g., first and second type of metal ionic species, and anionic species) and applying a voltage to the photoactive electrode, thereby forming a catalytic material comprising the components.

[0115] In some cases, a first type of anionic species and a second type of anionic species (e.g., a form of borate and a form of phosphate) may be provided to the solution and/or otherwise used in combination in a catalytic material of the invention. Where both first and second catalytically active anionic species are used, they can be selected from among anionic species described as suitable for use herein.

[0116] In some instances, the first type of anionic species is hydroxide and/or oxide ions, and the second type of anionic species is not hydroxide and/or oxide ions. It should be under-

stood, however, that when at least type of anionic species is an oxide or hydroxide, the species might not be provided to the solution but instead, may be present in the water or solution the species is provided in and/or may be formed during a reaction (e.g., between the first type of anionic species and the metal ionic species).

[0117] In some embodiments, the catalytic metal ionic species/anionic species do not consist essentially of metal ionic species/ O^{-2} and/or metal ionic species/ OH^{-} . A material “consists essentially of” a species if it is made of that species and no other species that significantly alters the characteristics of the material, for purposes of the invention, as compared to the original species in pure form. Accordingly, where a catalytic material does not consist essentially of metal ionic species/ O^{-2} and/or metal ionic species/ OH^{-} , the catalytic material has characteristics significantly different than a pure metal ionic species/ O^{-2} and/or metal ionic species/ OH^{-} , or a mixture. In some cases, a composition that does not consist essentially of metal ionic species/ O^{-2} and/or metal ionic species/ OH^{-} comprises less than about 90%, less than about 80%, less than about 70%, less than about 60%, less than about 50%, less than about 40%, less than about 30%, less than about 20%, less than about 10%, less than about 5%, less than about 1%, and the like, weight percent of O^{-2} and/or OH^{-} ions/molecules. In some instances, the composition that does not consist essentially of metal ionic species/ O^{-2} and/or metal ionic species/ OH^{-} comprises between about 1% and about 99%, between about 1% and about 90%, between about 1% and about 80%, between about 1% and about 70%, between about 1% and about 60%, between about 1% and about 50%, between about 1% and about 25%, etc., weight percent O^{-2} and/or OH^{-} ions/molecules. The weight percent of O^{-2} and/or OH^{-} ions/molecules may be determined using methods known to those of ordinary skill in the art. For example, the weight percent may be determined by determining the approximate structure of the material comprise in the composition. The weight percentage of the O^{-2} and/or OH^{-} ions/molecules may be determined by dividing the weight of O^{-2} and/or OH^{-} ions/molecules over the total weight of the composition multiplied by 100%. As another example, in some cases, the weight percentage may be approximately determined based upon the ratio of metal ionic species to anionic species in a composition and knowledge regarding the general coordination chemistry of the metal ionic species.

[0118] In a specific embodiment, the composition (e.g., catalytic material) associated with the photoactive electrode may comprise cobalt ions and anionic species comprising phosphorus (e.g., HPO_4^{-2}). In some cases, the composition may additionally comprise cationic species (e.g., K^{+}). In some cases, the photoactive electrode with which the composition is associated does not consist essentially of platinum. An anionic species comprising phosphorus may be any molecule that comprises phosphorus and is associated with a negative charge. Non-limiting examples of anionic species comprising phosphorus include H_3PO_4 , $H_2PO_4^{-}$, HPO_4^{-2} , PO_4^{-3} , H_3PO_3 , $H_2PO_3^{-}$, HPO_3^{-2} , PO_3^{-3} , $R^1PO(OH)_2$, $R^1PO_2(OH)^{-}$, $R^1PO_3^{-2}$, or the like, wherein R^1 is H, an alkyl, an alkenyl, an alkynyl, a heteroalkyl, a heteroalkenyl, a heteroalkynyl, an aryl, or a heteroaryl, all optionally substituted.

[0119] In some embodiments, a catalytic material of the invention, especially when associated with the photoactive electrode, may be substantially non-crystalline. Without wishing to be bound by theory, a substantially non-crystalline material may aid in the transport of protons and/or electrons,

which may improve the function of the photoanode in certain electrochemical devices. For example, improved transport of protons (e.g., increase proton flux) during electrolysis may improve the overall efficiency of an electrochemical device comprising a photoanode as described herein. A photoanode comprising a substantially non-crystalline catalytic material may allow for a conductivity of protons of at least about 10^{-1} $S\ cm^{-1}$, at least about 20^{-1} $S\ cm^{-1}$, at least about 30^{-1} $S\ cm^{-1}$, at least about 40^{-1} $S\ cm^{-1}$, at least about 50^{-1} $S\ cm^{-1}$, at least about 60^{-1} $S\ cm^{-1}$, at least about 80^{-1} $S\ cm^{-1}$, at least about 100^{-1} $S\ cm^{-1}$, and the like. In other embodiments, the catalytic material may be amorphous, substantially crystalline, or crystalline. Where substantially non-crystalline material is used, this would be readily understood by those of ordinary skill in the art and easily determined using various spectroscopic techniques.

[0120] The above and other characteristics of the metal ionic species and anionic species can serve as selective screening tests for identification of particular metal ionic and anionic species useful for particular applications. Those of ordinary skill in the art can, through simple bench-top testing, reference to scientific literature, simple diffractive instrumentation, simple electrochemical testing, and the like, select metal ionic and anionic species based upon the present disclosure, without undue experimentation.

[0121] In some cases, the catalytic material associated with the photoactive electrode may be porous, substantially porous, non-porous, and/or substantially non-porous. The pores may comprise a range of sizes and/or be substantially uniform in size. In some cases, the pores may or may not be visible using imaging techniques (e.g., scanning electron microscope). The pores may be open and/or closed pores. In some cases, the pores may provide pathways between the bulk electrolyte surface and the surface of the photoactive electrode.

[0122] In some instances, the catalytic material may be hydrated. That is, the catalytic material may comprise water and/or other liquid and/or gas components. Upon removal of the photoactive electrode comprising the catalytic material from solution, the catalytic material may be dehydrated (e.g., the water and/or other liquid and/or gas components may be removed from the catalytic material). In some cases, the catalytic material may be dehydrated by removing the material from solution and leaving the material to sit under ambient conditions (e.g., room temperature, air, etc.) for at least about 1 hour, at least about 2 hours, at least about 4 hours, at least about 8 hours, at least about 12 hours, at least about 24 hours, at least about 2 days, at least about 1 week, or more. In some cases, the catalytic material may be dehydrated under non-ambient conditions. For example, the catalytic material be dehydrated at elevated temperature and/or under vacuum. In some instances, the catalytic material may change composition and/or morphology upon dehydration. For example, in instances where the catalytic material forms a film, the film may comprise cracks upon dehydration.

[0123] Without wishing to be bound by theory, in some cases, the catalytic material may reach a maximum performance (e.g., rate of O_2 production, overpotential at a specific current density, onset potential, Faradaic efficiency, etc.) based upon the thickness of the catalytic material. Where a porous photoactive electrode is used, the thickness of the deposited catalytic material and the pore size of photoactive electrode may advantageously be selected in combination so that pores are not substantially filled with the catalytic mate-

rial. For example, the surface of the pores may comprise a layer of the catalytic material that is thinner than the average radius of the pores, thereby allowing for sufficient porosity to remain, even after catalytic material is deposited, so that the high surface area provided by the porous photoactive electrode is substantially maintained. In some cases, the average thickness of the catalytic material may be less than about 90%, less than about 80%, less than about 70%, less than about 60%, less than about 50%, less than about 40%, less than about 30%, less than about 20%, less than about 10%, or less, the average radius of the pores of the photoactive electrode. In some cases, the average thickness of the catalytic material may be between about 40% and about 60%, between about 30% and about 70%, between about 20% and about 80%, etc., the average radius of the pores of the photoactive electrode. In other embodiments, the performance of the catalytic material might not reach a maximum performance based upon the thickness of the catalytic material. In other embodiments, the performance of the catalytic material might not reach a maximum performance based upon the thickness of the catalytic material. In some cases, the performance (e.g., overpotential at a certain current density may decrease) of the catalytic material may increase with increasing thickness of the catalytic material. Without wishing to be bound by theory, this may indicate greater than just the outside layer of the catalytic material is catalytically active.

[0124] The physical structure of the catalytic material may vary. For example, the catalytic material may be a film and/or particles associated with at least a portion of the photoactive electrode (e.g., surface and/or pores) that is immersed in the solution. In some embodiments, the catalytic material might not form a film associated with the photoactive electrode. Alternatively or in addition, the catalytic material may be deposited on a photoactive electrode as patches, islands, or some other pattern (e.g., lines, spots, rectangles), or may take the form of dendrimers, nanospheres, nanorods, or the like. A pattern in some cases can form spontaneously upon deposition of catalytic material onto the photoactive electrode and/or can be patterned onto a photoactive electrode by a variety of techniques known to those of ordinary skill in the art (lithographically, via microcontact printing, etc.) and as discussed herein. Further, a photoactive electrode may be patterned itself such that certain areas facilitate association of the catalytic material while other areas do not, or do so to a lesser degree, thereby creating a patterned arrangement of catalytic material on the photoactive electrode as the photoanode is formed. Where a catalytic material is patterned onto a photoanode, the pattern might define areas of catalytic material and areas completely free of catalytic material, or areas with a particular amount of catalytic material and other areas with a different amount of catalytic material deposition. The catalytic material may have an appearance of being smooth and/or bumpy. In some cases, the catalytic material may comprise cracks, as can be the case when the material dehydrated.

[0125] In some cases, the thickness of catalytic material may be of substantially the same throughout the material. In other cases, the thickness of the catalytic material may vary throughout the material (e.g., a film does not necessarily have uniform thickness). The thickness of the catalytic material may be determined by determining the thickness of the material at a plurality of areas (e.g., at least 2, at least 4, at least 6, at least 10, at least 20, at least 40, at least 50, at least 100, or more areas) and calculating the average thickness. Where thickness of a catalytic material is determined via probing at

a plurality of areas, the areas should be selected so as not to specifically represent areas of more or less catalytic material presence based upon a pattern. Those of ordinary skill in the art will easily be able to establish a thickness-determining protocol that accounts for any non-uniformity or patterning of catalytic material on the surface. For example, the technique might include a sufficiently large number of area determinations, randomly selected, to provide overall average thickness. The average thickness of the catalytic material may be at least about 10 nm, at least about 100 nm, at least about 300 nm, at least about 500 nm, at least about 700 nm, at least about 1 μ m (micrometer), at least about 2 μ m, at least about 5 μ m, at least about 1 mm, at least about 1 cm, and the like. In some cases, the average thickness of the catalytic material may be less than about 1 mm, less than about 500 μ m, less than about 100 μ m, less than about 10 μ m, less than about 1 μ m, less than about 100 nm, less than about 10 nm, less than about 1 nm, less than about 0.1 nm, or the like. In some instances, the average thickness of the catalytic material may be between about 1 mm and about 0.1 nm, between about 500 μ m and about 1 nm, between about 100 μ m and about 1 nm, between about 100 μ m and about 0.1 nm, between about 0.2 μ m and about 2 μ m, between about 200 μ m and about 0.1 μ m, or the like. In particular embodiments, the catalytic material may have an average thickness of less than about 0.2 μ m. In another embodiment, the catalytic material may have an average thickness between about 0.2 μ m and about 2 μ m. The average thickness of the catalytic material may be varied by altering the amount and length of time a voltage is applied to the photoactive electrode, the concentration of the metal ionic species and the anionic species in solution, the surface area of the photoactive electrode, the surface area density of the photoactive electrode, and the like.

[0126] In some cases, the average thickness of the catalytic material may be determined according to the following method. A photoanode comprising a photoactive electrode and a catalytic material may be removed from solution (e.g., the solution the photoanode was formed in and/or the electrolyte). The photoanode may be left to dry for about 1 hour, about 2 hours, about 4 hours, about 6 hours, about 8 hours, about 12 hours, about 24 hours, or more. In some cases, the photoanode may be dried under ambient conditions (e.g., in air at room temperature). In some embodiments, during drying, the catalytic material may crack. The thickness of the catalytic material may be determined using techniques known to those of ordinary skill in the art (e.g., scanning electron microscope (SEM)) to determine the depth of the cracks (e.g., the thickness of the dehydrated catalytic material).

[0127] In other embodiments, the thickness of the catalytic material may be determined without dehydration (e.g., in situ) using techniques known to those of ordinary skill in the art, for example, SEM. In such embodiments, a mark (e.g., scratch, hole) may be made in the catalytic material to expose at least a portion of the underlying substrate (e.g., the photoactive electrode). The thickness of the catalytic material may be determined by measuring the depth of the mark.

[0128] In some embodiments, a film of the catalytic material may be formed by the coalescing of a plurality of particles formed on the photoactive electrode. In some cases, the material may be observed to have the physical appearance of a base layer of material comprising a plurality of groups of protruding particles. The thickness of the film may be determined by the thickness of the base layer, although it should be under-

stood that the thickness would be substantially greater if measured by determining the thickness of the areas comprising protruding particles.

[0129] Without wishing to be bound by theory, the formation of groups of protruding particles on the surface of the film may aid in increasing the surface area and thus increase the production of oxygen gas. That is, the surface area of the catalytic material comprising a plurality of groups of protruding particles may be substantially greater than the surface area of a catalytic material which does not comprise a plurality of groups of protruding particles.

[0130] In some embodiments, the catalytic material may be described as a function of mass of catalytic material per unit area of the photoactive electrode. In some cases, the mass of catalytic material per area of the photoactive electrode may be about 0.01 mg/cm², about 0.05 mg/cm², about 0.1 mg/cm², about 0.5 mg/cm², about 1.0 mg/cm², about 1.5 mg/cm², about 2.5 mg/cm², about 3.0 mg/cm², about 4.0 mg/cm², about 5.0 mg/cm², or the like. In some cases, the mass of catalytic material per unit area of the photoactive electrode may be between about 0.1 mg/cm² and about 5.0 mg/cm², between about 0.5 mg/cm² and about 3.0 mg/cm², between about 1.0 mg/cm² and about 2.0 mg/cm², and the like. Where the amount of catalytic material associated with a photoactive electrode is defined or investigated in terms of mass per unit area, and the material is present non-uniformly relative to the photoactive electrode surface (whether through patterning or natural variations in amount over the surface), the mass per unit area may be averaged across the entire surface area within which catalytic material is found (e.g., the geometric surface area). In some cases, the mass of the catalytic material per unit area may be a function of the thickness of the catalytic material.

[0131] The formation of the catalytic material may proceed until the voltage applied to the photoactive electrode is turned off (e.g., the power source or the light source is turned off/removed), until there is a limiting quantity of materials (e.g., metal ionic species and/or anionic species) and/or the catalytic material has reached a critical thickness beyond which additional film formation does not occur or is very slow. Voltage may be applied to the photoactive electrode for minimums of about 1 minute, about 5 minutes, about 10 minutes, about 20 minutes, about 30 minutes, about 60 minutes, about 2 hours, about 4 hours, about 8 hours, about 12 hours, about 24 hours, and the like. In some cases, a potential may be applied to the photoactive electrode between 24 hours and about 30 seconds, between about 12 hours and about 1 minute, between about 8 hours and about 5 minutes, between about 4 hours and about 10 minutes, and the like. The voltages provided herein, in some cases, are supplied with reference to a 'normal hydrogen electrode' (NHE). Those of ordinary skill in the art will be able to determine the corresponding voltages with respect to an alternative reference electrode by knowing the voltage difference between the specified reference electrode and NHE or by referring to an appropriate textbook or reference. The formation of the catalytic material may proceed until about 0.1%, about 1%, about 5%, about 10%, about 20%, about 30%, about 40%, about 50%, about 60%, about 70%, about 80%, about 90%, about 99%, about 100% of the metal ionic species and/or anionic species initially added to the solution have associated with the photoactive electrode to form the catalytic material.

[0132] The voltage applied to the photoactive electrode (e.g., via an external power source or by exposing the photo-

active electrode to electromagnetic radiation) may be held steady, may be linearly increased or decreased, and/or may be linearly increased and decreased (e.g., cyclic). In some cases, the voltage applied to the photoactive electrode may be substantially similar throughout the application of the voltage. That is, the voltage applied to the photoactive electrode might not be varied significantly during the time that the voltage is applied to the photoactive electrode. In some instances, the voltage applied to the current collect by an external power source may be at least about 0.1 V, at least about 0.2 V, at least about 0.4 V, at least about 0.5 V, at least about 0.7 V, at least about 0.8 V, at least about 0.9 V, at least about 1.0 V, at least about 1.2 V, at least about 1.4 V, at least about 1.6 V, at least about 1.8 V, at least about 2.0 V, at least about 3 V, at least about 4 V, at least about 5 V, at least about 10 V, and the like. In some cases, the voltage applied is between about 1.0 V and about 1.5 V, about 1.1 V and about 1.4 V, or is about 1.1 V. In some instances, the voltage applied to the photoactive electrode may be a linear range of voltages, and/or cyclic range of voltages. Application of a linear voltage refers to instances where the voltage applied to the photoanode (and/or photoactive electrode) is swept linearly in time between a first voltage and a second voltage. Application of a cyclic voltage refers to application of linear voltage, followed by a second application of linear voltage wherein the sweep direction has been reversed. For example, application of a cyclic voltage is commonly used in cyclic voltammetry studies. In some cases, the first voltage and the second voltage may differ by about 0.1 V, about 0.2 V, about 0.3 V, about 0.5 V, about 0.8 V, about 1.0 V, about 1.5 V, about 2.0 V, or the like. In some cases, the voltage may be swept between the first voltage and the second voltage at a rate of about 0.1 mV/sec, about 0.2 mV/sec, about 0.3 mV/sec, about 0.4 mV/sec, about 0.5 mV/sec, about 1.0 mV/sec, about 10 mV/sec, about 100 mV/sec, about 1 V/sec, or the like. The potential applied may or might not be such that oxygen gas is being formed during the formation of the photoanode. In some cases, the morphology of the catalytic material may differ depending on the potential applied to the photoactive electrode during formation of the photoanode.

[0133] In some embodiments, wherein the catalytic material is a regenerative material, between application of a voltage (e.g., during periods when the photoanode is not in use), at least about 1%, at least about 2%, at least about 5%, at least about 10%, at least about 20%, or more, by weight of the catalytic material may dissociate from the photoactive electrode over a period of about 10 minutes, about 30 minutes, about 1 hour, about 2 hours, about 6 hours, about 12 hours, about 24 hours, or more. Upon reapplication of the voltage, at least about 50%, at least about 60%, at least about 70%, at least about 80%, at least about 90%, at least about 95%, at least about 99%, or more, by weight of the dissociate material may re-associate with the photoanode. In some cases, substantially all of the metal ionic species may re-associate with the photoanode and only a portion of the anionic species may re-associate with the photoanode (e.g., in instances where the electrolyte comprises anionic species and there may be an exchange of the anionic species which dissociate and those which re-associate).

[0134] In another embodiment, a photoanode of system comprising a catalytic material may be prepared as follows. A catalytic material may be associated with a photoactive electrode as described above in any manner described herein. For example, at relatively low potentials at which oxygen gas is not evolved, and/or at a higher potentials at which oxygen gas

is evolved and a higher rate of deposition of material on the photoanode occurs, and/or at any other rate or under any conditions suitable for production of a catalytic material associated with the photoactive electrode. The catalytic material can be removed from the photoactive electrode (and, optionally, the process can be cyclically repeated with additional catalytic material associated with the photoanode, removed, etc.) and the catalytic material can be optionally dried, stored, and/or mixed with an additive (e.g., a binder) or the like. The catalytic material may be packaged for distribution and used as a catalytic material. In some cases, the catalytic material can later be applied to a photoactive electrode, can simply be added to a solution of water and associated with a different photoactive electrode as described above, e.g., in an end-use setting, or used otherwise as would be recognized by those of ordinary skill in the art. Those of ordinary skill in the art can readily select binders that would be useful for addition to such catalytic material, for example, poly tetrafluoroethylene (Teflon™), Nafion™, or the like. For eventual use in an electrolyzer, photoelectrochemical cell, or other electrolysis system, non-conductive binders may be most suitable. Conductive binders may be used where they are stable to photoelectrochemical conditions.

[0135] In some embodiments, after application of the voltage and formation of a photoanode comprising a photoactive electrode, metal ionic species, and anionic species, the photoanode may be removed from the solution and stored. The photoanode may be stored for any period of time or used immediately in one of the applications discussed herein. In some cases, the catalytic material associated with the photoactive electrode may dehydrate during storage. The photoanode may be stored for at least about 1 day, at least about 2 days, at least about 5 days, at least about 10 days, at least about 1 month, at least about 3 months, at least about 6 months or at least about 1 year, with no more than 10% loss in photoanode performance per month of storage, or no more than 5%, or even 2%, loss in performance per month of storage. Photoanodes as described herein may be stored under varying conditions. In some instances, the photoanode may be stored in ambient conditions and/or under an atmosphere of air. In other instances, the photoanode may be stored under vacuum. In yet another instance, the photoanode may be stored in solution. In this case, the catalytic material may disassociate from the photoactive electrode over a period of time (e.g., 1 day, 1 week, 1 month, and the like) to form metal ionic species and anionic species in solution. Application of a voltage and/or a photovoltage to the photoactive electrode, in most cases, may cause the metal ionic species and anionic species to re-associate with the photoactive electrode to reform the catalytic material.

[0136] In some embodiments, a photoanode comprising a photoactive electrode and a catalytic material may be used for an extended period of time as compared to the photoactive electrode alone, under essentially identical conditions. Without wishing to be bound by theory, the dynamic equilibrium of the catalytic material may cause the photoanode to be robust and provides a self-repair mechanism. In some cases, a photoanode may be used to catalytically produce oxygen gas from water for at least about 1 month, at least about 2 months, at least about 3 months, at least about 6 months, at least about 1 year, at least about 18 months, at least about 2 years, at least about 3 years, at least about 5 years, at least about 10 years, or greater, with less than 50%, less than 40%, less than 30%, less than 20%, less than 10%, less than 5%,

less than 3%, less than 2%, less than 1%, or less, change in a selected performance measure (e.g., overpotential, rate of production of oxygen, etc.).

[0137] In some cases, the composition of the catalytic material associated with the photoactive electrode after storage may be substantially similar to the catalytic material immediately after formation. In other cases, the composition of the catalytic material associated with the photoactive electrode after storage may be substantially different than the catalytic material immediately after formation. In some instances, the metal ionic species in the catalytic material may be oxidized as compared to the metal ionic species in solution. For example, the metal ionic species immediately after deposition may have an oxidation state of $(n+x)$, and after storage, at least a portion of the metal ionic species may have an oxidation state of (n) . The ratio of metal ionic species to anionic species in the catalytic material after storage may or might not be substantially similar to the ratio present immediately after formation.

[0138] The solution in which the photoactive electrode is immersed may be formed from any suitable material. In most cases, the solution may be a liquid and may comprise water. In some embodiments the solution may consist of or consist essentially of water, i.e. be essentially pure water or an aqueous solution that behaves essentially identical to pure water, in each case, with the minimum electrical conductivity necessary for an electrochemical device to function. In some embodiments, the solution may be selected such that the metal ionic species and the anionic species are substantially soluble. In some cases, when the photoanode is to be used in a device immediately after formation, the solution may be selected such that it comprises water (or other fuel) to be oxidized by a device and/or method as described herein. For example, in instances where oxygen gas is to be catalytically produced from water, the solution may comprise water (e.g., provided from a water source). In some cases, the solution may be contained within a container which is substantially transparent to visible light (e.g., such that the photoactive electrode may be exposed to electromagnetic radiation through the container).

[0139] The metal ionic species and the anionic species may be provided to the solution by substantially dissolving compounds comprising the metal ionic species and the anionic species. In some instances, this may comprise substantially dissolving a metal compound comprising the metal ionic species and anionic compound comprising the anionic species. In other instances, a single compound may be dissolved that comprises both the metal ionic species and the anionic species. The metal compound and/or the anionic compound may be of any composition, such as a solid, a liquid, a gas, a gel, a crystalline material, and the like. The dissolution of the metal compound and anionic compound may be facilitated by agitation of the solution (e.g., stirring) and/or heating of the solution. In some cases, the solution may be sonicated. The metal species and/or anionic species may be provided in an amount such that the concentration of the metal ionic species and/or anionic species is at least about 0.1 mM, at least about 0.5 mM, at least about 1 mM, at least about 10 mM, at least about 0.1 M, at least about 0.5 M, at least about 1 M, at least about 2 M, at least about 5M, and the like. In some cases, the concentration of the anionic species may be greater than the concentration of the metal ionic species, so as to facilitate the formation of the catalytic material, as described herein. As non-limiting examples, the concentration of the anionic spe-

cies may be about 2 times greater, about 5 times greater, about 10 times greater, about 25 times greater, about 50 times greater, about 100 times greater, about 500 times greater, about 1000 times greater, and the like, of the concentration of the metal ionic species. In some instances, the concentration of the metal ionic species will be greater than the concentration of the anionic species.

[0140] In some cases, the pH of the solution may be about neutral. That is, the pH of the solution may be between about 6.0 and about 8.0, between about 6.5 and about 7.5, and/or the pH is about 7.0. In other cases, the pH of the solution is about neutral or acidic. In these cases, the pH may be between about 0 and about 8, between about 1 and about 8, between about 2 and about 8, between about 3 and about 8, between about 4 and about 8, between about 5 and about 8, between about 0 and about 7.5, between about 1 and about 7.5, between about 2 and about 7.5, between about 3 and about 7.5, between about 4 and about 7.5, or between about 5 and about 7.5. In yet other cases, the pH may be between about 6 and about 10, between about 6 and about 11, between about 7 and about 14, between about 2 and about 12, and the like. In some embodiments, the pH of the solution may be about neutral and/or basic, for example, between about 7 and about 14, between about 8 and about 14, between about 8 and about 13, between about 10 and about 14, greater than 14, or the like. The pH of the solution may be selected such that the anionic species and the metal ionic species are in the desired state. For example, some anionic species may be affected by a change in pH level, for example, phosphate. If the solution is basic (greater than about pH 12), the majority of the phosphate is the form PO_4^{-3} . If the solution is approximately neutral, the phosphate is in approximately equal amounts of the form HPO_4^{-2} and the form $\text{H}_2\text{PO}_4^{-1}$. If the solution is slightly acidic (less than about pH 6), the phosphate is mostly in the form $\text{H}_2\text{PO}_4^{-}$. The pH level may also affect the solubility constant for the anionic species and the metal ionic species.

[0141] In one embodiment, a photoanode as described herein may comprise a photoactive electrode and a composition comprising metal ionic species and anionic species in electrical communication with the photoactive electrode. The composition, in some cases, may be formed by self-assembly of the metal ionic species and anionic species on the photoactive electrode and be sufficiently non-crystalline such that the composition allows for the conduction of protons. In some embodiments, a photoanode may allow for a conductivity of protons of at least $10^{-1} \text{ S cm}^{-1}$, at least about $20^{-1} \text{ S cm}^{-1}$, at least about $30^{-1} \text{ S cm}^{-1}$, at least about $40^{-1} \text{ S cm}^{-1}$, at least about $50^{-1} \text{ S cm}^{-1}$, at least about 60 S cm^{-1} , at least about 80 S cm^{-1} , at least about 100 S cm^{-1} , and the like.

[0142] In some embodiments, a photoanode as described herein may be capable of producing oxygen gas from water at a low overpotential. Voltage in addition to a thermodynamically determined reduction or oxidation potential that is required to attain a given catalytic activity is herein referred to as "overpotential," and may limit the efficiency of the electrochemical device (e.g., photoelectrochemical device). Overpotential is therefore given its ordinary meaning in the art, that is, it is the potential that must be applied to a component of a system such as a photoanode to bring about an electrochemical reaction (e.g., formation of oxygen gas from water) minus the thermodynamic potential required for the reaction. Those of ordinary skill in the art understand that the total potential that must be applied to a particular system in order to drive a reaction is typically the total of the potentials

that must be applied to the various components of the system. For example, the potential for an entire system is typically higher than the potential as measured at, e.g., a photoanode at which oxygen gas is produced from the electrolysis of water. Those of ordinary skill in the art will recognize that where overpotential for oxygen production from water electrolysis is discussed herein, this applies to the voltage required for the conversion of water to oxygen itself, and does not include voltage drop at the counter electrode.

[0143] The thermodynamic potential for the production of oxygen gas from water varies depending on the conditions of the reaction (e.g., pH, temperature, pressure, etc.). Those of ordinary skill in the art will be able to determine the required thermodynamic potential for the production of oxygen gas from water depending on the experimental conditions. For example, the pH dependence of water oxidation may be determined from a simplified form of the Nernst equation to give Equation 18:

$$E_{pH} = E^\circ - 0.059V \times (\text{pH}) \quad (18)$$

where E_{pH} is the potential at a given pH, E° is the potential under standard conditions (e.g., 1 atm, about 25° C.) and pH is the pH of the solution. For example, at pH 0, $E=1.229 \text{ V}$, at pH 7, $E=0.816 \text{ V}$, and at pH 14, $E=0.403 \text{ V}$.

[0144] The thermodynamic potential for the production of oxygen gas from water at a specific temperature (E_T) may be determined using Equation 19:

$$E_T = [1.5184 - (1.5421 \times 10^{-3})(T)] + [(9.523 \times 10^{-5})(T) \ln(T)] + [(9.84 \times 10^{-8})T^2] \quad (19)$$

where T is given in Kelvin. For example, at 25° C., $E_T=1.229 \text{ V}$, and at 80° C., $E_T=1.18 \text{ V}$.

[0145] The thermodynamic potential for the production of oxygen gas from water at a given pressure (E_p) may be determined using Equation 20:

$$E_p = E_T + \left(\frac{RT}{2F}\right) \ln\left\{[(P - P_w)^{1.5}] \div \left(\frac{P_w}{P_{wo}}\right)\right\} \quad (20)$$

where T is in Kelvin, F is Faraday's constant, R is the universal gas constant, P is the operating pressure of the electrolyzer, P_w is the partial pressure of water vapor over the chosen electrolyte, and P_{wo} is the partial pressure of water vapor over pure water. By this equation, at a 25° C., the E_p increases by 43 mV for a tenfold increase in pressure.

[0146] In some instances, a photoanode as described herein may be capable of catalytically producing oxygen gas from water (e.g., gaseous and/or liquid water) with an overpotential of less than about 1 volt, less than about 0.75 volts, less than about 0.6 volts, less than about 0.5 volts, less than about 0.4 volts, less than about 0.35 volts, less than about 0.325 volts, less than about 0.3 volts, less than about 0.25 volts, less than about 0.2 volts, less than about 0.1 volts, or the like. In some embodiments, the overpotential is between about 0.1 volts and about 0.4 volts, between about 0.2 volts and about 0.4 volts, between about 0.25 volts and about 0.4 volts, between about 0.3 volts and about 0.4 volts, between about 0.25 volts and about 0.35 volts, or the like. In another embodiment, the overpotential is about 0.325 volts. In some cases, the overpotential of a photoanode is determined under standardized conditions of an electrolyte with a neutral pH (e.g., about pH 7.0), ambient temperature (e.g., about 25° C.), ambient pressure (e.g., about 1 atm), a photoactive electrode that is non-

porous and planar, and at a geometric current density (as described herein) of about 1 mA/cm². It is to be understood that systems of the invention can be used under conditions other than those described immediately above and in fact those of ordinary skill in the art will recognize that a very wide variety of conditions can exist in use of the invention. But the conditions noted above are provided only for the purpose of specifying how features such as overpotential, amount of oxygen and/or hydrogen produced, and other performance characteristics defined herein are measured for purposes of clarity of the present invention. In a specific embodiment, a catalytic material may produce oxygen gas from water at an overpotential of less than 0.4 volt at an electrode current density of at least 1 mA/cm². As described herein, the water which is oxidized may contain at least one impurity (e.g., NaCl), or be provided from an impure water source.

[0147] In some embodiment, a photoanode may be capable of catalytically producing oxygen gas from water (e.g., gaseous and/or liquid water) with a Faradaic efficiency of about 100%, greater than about 99.8%, greater than about 99.5%, greater than about 99%, greater than about 98%, greater than about 97%, greater than about 96%, greater than about 95%, greater than about 90%, greater than about 85%, greater than about 80%, greater than about 70%, greater than about 60%, greater than about 50%, etc. The term, "Faradaic efficiency," as used herein, is given its ordinary meaning in the art and refers to the efficacy with which charge (e.g., electrons) are transferred in a system facilitating an electrochemical reaction. Loss in Faradaic efficiency of a system may be caused, for example, by the misdirection of electrons which may participate in unproductive reactions, product recombination, short circuit the system, and other diversions of electrons and may result in the production of heat and/or chemical byproducts.

[0148] Faradaic efficiency may be determined, in some cases, through bulk electrolysis where a known quantity of reagent is stoichiometrically converted to product as measured by the current passed and this quantity may be compared to the observed quantity of product measured through another analytical method. For example, a device or photoanode may be used to catalytically produce oxygen gas from water. The total amount of oxygen produced may be measured using techniques known to those of ordinary skill in the art (e.g., using an oxygen sensor, a zirconia sensor, electrochemical methods, etc.). The total amount of oxygen that is expected to be produced may be determined using simple calculations from the amount of charge passed. The Faradaic efficiency may be determined by measuring the percentage of oxygen gas produced and comparing that value with the expected amount of oxygen gas produced based on the charge passed during photo-assisted electrolysis. In some cases, the Faradaic efficiency of a photoanode changes by less than about 0.1%, less than about 0.2%, less than about 0.3%, less than about 0.4%, less than about 0.5%, less than about 1.0%, less than about 2.0%, less than about 3.0%, less than about 4.0%, less than about 5.0%, etc., over a period of operation of the photoanode of about 1 day, about 2 days, about 3 days, about 5 days, about 15 days, about 1 month, about 2 months, about 3 months, about 6 months, about 12 months, about 18 months, about 2 years, etc.

[0149] As will be known to those of ordinary skill in the art, an example of a side reaction that may occur during the catalytic formation of oxygen gas from water is the production of hydrogen peroxide. The production of hydrogen per-

oxide may decrease the Faradaic efficiency of a photoanode. In some cases, a photoanode, in use, may produce oxygen that is in the form of hydrogen peroxide of less than about 0.01%, less than about 0.05%, less than about 0.1%, less than about 0.2%, less than about 0.3%, less than about 0.4%, less than about 0.5%, less than about 0.6%, less than about 0.7%, less than about 0.8%, less than about 0.9%, less than about 1%, less than about 1.5%, less than about 2%, less than about 3%, less than about 4%, less than about 5%, less than about 10%, etc. That is, less than this percentage of the molecules of oxygen produced is in the form of hydrogen peroxide. Those of ordinary skill in the art will be aware of methods for determining the production of hydrogen peroxide at a photoanode and/or methods to determine the percentage of hydrogen peroxide produced. For example, hydrogen peroxide may be determined using a rotating ring-disc electrode. Any products generated at the disk electrode are swept past the ring electrode. The potential of the ring electrode may be poised to detect hydrogen peroxide that may have been generated at the ring.

[0150] In some cases, the performance of a photoanode may also be expressed, in some embodiments, as a turnover frequency. The turnover frequency refers to the number of oxygen molecules produced per second per catalytic site. In some cases, a catalytic site may be a metal ionic species (e.g., a cobalt ion). The turnover frequency of a photoanode (e.g., comprising a photoactive electrode and a catalytic material) may be less than about 0.01, less than about 0.005, less than about 0.001, less than about 0.0007, less than about 0.0005, less than about 0.00001, less than about 0.000005, or less, moles of oxygen gas per second per catalytic site. In some cases, the turnover frequency may be determined under standardized conditions (e.g., ambient temperature and pressure, 1 mA/cm², planar photoactive electrode, etc.). Those of ordinary skill in the art will be aware of methods to determine the turnover frequency.

[0151] In one set of embodiments, the invention provides a photoanode and/or catalytic system which can facilitate photo-assisted electrolysis (or other electrochemical reactions) wherein a significant portion, or essentially all of the electrons provided to or withdrawn from a solution or material undergoing electrolysis are provided through reaction of catalytic material. For example, where essentially all the electrons provided to or withdrawn from a system undergoing electrolysis are involved in a catalytic reaction, essentially each electron added or withdrawn participates in a reaction involving change of a chemical state of at least one element of a catalytic material. In other embodiments, the invention provides a system where at least about 98%, at least about 95%, at least about 90%, at least about 80%, at least about 70%, at least about 60%, at least about 50%, at least about 40%, or at least about 30% of all electrons added to or withdrawn from a system undergoing electrolysis (e.g., water being split) are involved in a catalytic reaction. Where less than essentially all electrons added or withdrawn are involved in a catalytic reaction some electrons can simply be provided to and withdrawn from the electrolysis solution or material (e.g., water) directly to and from a photoactive electrode and/or photoanode which does participate in a catalytic reaction.

[0152] In some embodiments, systems and/or devices may be provided that comprise at least one photoanode as described herein and/or prepared using the methods described herein may be provided. In particular, a device may be a photoelectrochemical device. Non-limiting examples of

photoelectrochemical devices includes photoelectrochemical cells, bi-photoelectrochemical cells, hybrid photoelectrochemical cells, and the like. A photoelectrochemical device in some cases, may function as an oxygen gas and/or hydrogen gas generator by photoelectrochemically decomposing water (e.g., liquid and/or gaseous water) to produce oxygen and/or hydrogen gases. Fuel (e.g., water) may be provided to a device in a solid, liquid, gel, and/or gaseous state. In some cases, as described herein, the oxygen gas and/or hydrogen gas produced may be converted to water using a secondary device, for example, an energy conversion device such as a fuel cell. An energy conversion device, in some embodiments, may be used to provide at least a portion of the energy required to operate an automobile, a house, a village, a cooling device (e.g., a refrigerator), etc. In some cases, more than one device may be employed to provide the energy.

[0153] In some embodiments, a device may be used to produce O₂ and/or H₂. The O₂ and/or H₂ may be converted back into electricity and water (e.g., through use of a fuel cell). In some cases, however, the O₂ and/or H₂ may be used for other purposes. For example, the O₂ and/or H₂ may be burned to provide a source of heat. In some cases, O₂ may be used in combustion processes (e.g., burning of the hydrocarbon fuels such as oil, coal, petrol, natural gas) which may be used to heat homes, power cars, as rocket fuel, etc. In some instances, O₂ may be used in a chemical plant for the production and/or purification of a chemical (e.g., production of ethylene oxide, production of polymers, purification of molten ore). In some cases, the H₂ may be used to power a device (e.g., in a hydrogen fuel cell), wherein the O₂ may be released into the atmosphere and/or used for another purpose. In other cases, H₂ may be used for the production of a chemical or in a chemical plant (e.g., for hydrocracking, hydrodealkylation, hydrodesulfurization, hydrogenation (e.g., of fats, oils, etc.), etc.; for the production of methanol, acids (e.g., hydrochloric acid), ammonia, etc.). H₂ and O₂ may also be used for medical, industrial, and/or other scientific processes (e.g., as medical grade oxygen, combustion with acetylene in an oxy-acetylene torch for welding and cutting metals, etc.). Those of ordinary skill in the art will be aware of uses for O₂ and/or H₂. Other non-limiting examples of device uses include O₂ production (e.g., gaseous oxygen), H₂ production (e.g., gaseous hydrogen), H₂O₂ production, ammonia oxidation, hydrocarbon (e.g., methanol, methane, ethanol, and the like) oxidation, exhaust treatment, etc.

[0154] In some embodiments, a photoelectrochemical cell is provided that allows for electrochemically producing oxygen and/or hydrogen gases from water and systems and/or methods associated with the same. In some embodiments, the photoelectrochemical cell may comprise a photoanode (e.g., comprising a photoactive electrode and a catalytic material, wherein a catalytic material is integrally connected with the photoactive electrode (or photosensitizing agent)) and an electrode (or photocathode). The catalytic material may comprise metal ionic species and anionic species and/or may not consist essentially of metal oxide or metal hydroxide. Illumination of the device (e.g., by exposure to electromagnetic radiation) may produce oxygen gas. In some instances, hydrogen gas may also be produced at the electrode. As shown in FIG. 1, in a non-limiting configuration, a device comprises a chamber 128, a photoactive electrode 130, an electrode (or second photoactive electrode) 134, wherein the photoactive electrode is biased positively with respect to the electrode, means for connecting the photoactive electrode

and the electrode 131, an electrolyte 132, wherein the photoactive electrode and the electrode are in fluid contact with the electrolyte, and in most cases, a power source 138 in electrical communication with the photoactive electrode and the electrode. In some cases, the device may also comprise a resistor 136.

[0155] A photoactive electrode biased negatively or positively towards an electrode (or second photoactive electrode) means that the potential of the photoactive electrode is negative or positive with respect to the potential of the electrode (or second photoactive electrode). The electrode may be biased negatively or positively with respect to the photoactive electrode by less than about 1.23 V (e.g., the minimum defined by the thermodynamics of transforming water into oxygen and hydrogen gas), less than about 1.3 V, less than about 1.4 V, less than about 1.5 V, less than about 1.6 V, less than about 1.7 V, less than about 1.8 V, less than about 2 V, less than about 2.5 V, and the like. In some cases, the bias may be between about 1.5 V and about 2.0 V, about 1.6 V and about 1.9 V, or is about 1.6 V, between about 1 V and about 2.5 V, between about 1.5 and about 2.5 V, and the like. Voltage may be applied to the photoactive electrode (e.g., via an external power source and/or by exposing the photoactive electrode to light) to generate electron-hole pairs. The electron-hole pairs may be separated between the photoactive electrode and the electrode, to produce photoelectrochemical reduction and photoelectrochemical oxidation reactions at the electrode and photoactive electrode, respectively, thereby producing oxygen gas. In the case of the photoactive electrode, holes combine with water molecules (H₂O) to produce an oxidation reaction, thereby producing oxygen gas. The reverse reaction may occur at the electrode, where electrons combine with protons (e.g., H⁺, or a proton source), to produce a reduction reaction, thereby producing hydrogen gas. The net effect is a flow of electrons from the first photoactive electrode to the second electrode, resulting in reduction at the latter (hydrogen gas formation), and oxidation at the former (oxygen gas formation). In some cases, the hydrogen and/or oxygen gases produced may be stored and used in further reactions.

[0156] As another non-limiting embodiment, in some cases, the photoelectrochemical cell may comprise a hybrid photovoltaic/photoelectrode. A hybrid photovoltaic/photoelectrode generally comprises a photoelectrode that is electrolytically active (e.g., an electrode where water oxidation takes place), a photovoltaic cell, which acts to provide a voltage bias to the photoelectrode, and a electrode (e.g., where the corresponding reduction of protons may occur to fulfill the second half-reaction in overall water splitting for the device.). A non-limiting illustration of a photoelectrochemical cell is shown in FIG. 10. In this figure, the hybrid photovoltaic/photoelectrode comprises photoanode 202 in electrical connection with p-n junction solar cell 204 (e.g., comprising silicon), electrode 206, and in some cases, coating 200 to protect the solar cell and electrode from outside exposure (e.g., to the electrolyte, etc.). Upon exposure to light, the photoanode absorbs photons having energy equal to or greater than its band gap while the rest of the light is transmitted to the solar cell. The solar cell provides the additional energy required to bias the device for water electrolysis.

[0157] A non-limiting example of a photoelectrochemical cell is depicted in FIG. 11. The photoelectrochemical cell comprises housing 298, in which at least one section or side of the housing is substantially transparent to light (e.g., wall 298a and walls 298). During operation, the photoelectro-

chemical cell may be illuminated on the wall(s) which are substantially transparent. The housing may comprise at least first outlet **320** and second outlet **322** for the collection of O₂ and H₂ gases, respectively, produced during the photoelectrochemical reaction. The housing may comprise at least one photovoltaic cell comprising first electrode (or photoanode) **306**, and second electrode (or photocathode) **302**. In some cases, material **304** may be present between the first electrode and the second electrode (e.g., a non-doped semiconductor). The cell also comprises an electrolyte (e.g., **300**, **318**). The cell also may comprise material **316**. Material **316** may be a porous electrically conductive material (e.g., valve metal, metallic compound) wherein the electrolyte (e.g., **318**) fills the pores of the material. In some embodiments, a catalytic material **308** may associate with material **316** (e.g., indirect association) as compared to direct association with the photoactive electrode (or electrode). Without wishing to be bound by theory, material **316** may act as a membrane and may allow for the transmission of electrons generated at first electrode (or photoactive electrode) **306** to outer surface **324** of material **316**. Material **316** may also be selected such that no oxygen gas is produced in the pores of material **316**, for example, if the overpotential for production of oxygen gas is high. Oxygen gas may form on or near surface **324** of material **316** (e.g., via the composition associated with outer surface **324** or material **316**). Non-limiting examples of materials which may be suitable for use as material **316** includes titanium, zirconium, vanadium, hafnium, niobium, tantalum, tungsten, or alloys thereof. In some cases, the material may be a valve metal nitride, carbide, borides, etc., for example, titanium nitride, titanium carbide, or titanium boride. In some cases, the material may be titanium oxide, or doped titanium oxide (e.g., with niobium, tantalum, tungsten, fluorine, etc.).

[0158] In some cases, a photoelectrochemical cell may be a bi-photoelectrochemical device or tandem photoelectrochemical cell and may comprise a first and a second photoelectrode. The first and second photoelectrodes may work in tandem to split water to produce hydrogen and oxygen gases using electromagnetic radiation (e.g., visible light, solar energy). The first and the second photoelectrodes may be in electrical communication with one another. A non-limiting arrangement of a bi-photoelectrochemical cell is shown in FIG. 12. In this figure, **150-1** and **151** are transparent materials (e.g., glass) through which light can pass. The light may pass through material **150-1** and through electrolyte **152** (e.g., aqueous electrolyte) and impinge on a photoelectrode comprising components **153** (e.g., light absorbing material, catalytic material, etc.) and **154-1** (e.g., material which may collect electrons produced by light absorbing material, catalytic material, etc.). In some cases, in this device, photoelectrode **153/154-1** may absorb only a part of the visible light spectrum (e.g., blue and green light) and the remainder of the spectrum (e.g., red and yellow light) may pass through another transparent material (e.g., glass, **150-2**) to a second cell. Oxygen gas may be produced at photoelectrode **153/154-1**. The second cell may comprise material **154-2** (e.g., a conducting oxide material) and material **156** (e.g., a dye-derivatized metal oxide material), which may function as a light-driven electric bias and may increase the electrochemical potential of the electrons which emerge from photoelectrode **153/154-1**. The second cell may also comprise electrolyte **157** (e.g., organic redox electrolyte) and counter electrode **158**. Behind counter electrode **158**, there may also be a compartment comprising electrolyte **159**, in which hydrogen gas may be

produced at cathode **160**. Electrolytes **152** and **159** may be substantially similar, in some embodiments, and may be connected by an ion-conducting membrane or glass frit **161**.

[0159] As another example, as shown in FIG. 13, a bi-photoelectrochemical cell may comprise first photoelectrode **180** (e.g., comprising a photoanode as described herein), second photoelectrode **182** biased negatively with respect to the first photoelectrode (e.g., photocathode such as p-type GaP), electrolyte **190** (e.g., an aqueous electrolyte), and means for connecting **184** the first and the second photoelectrode. In some cases, the bi-photoelectrochemical cell may optionally comprise power source **188** (e.g., especially in cases where the photoanode and the photocathode comprise similar materials but are differently doped such as p-type and n-type TiO₂) and/or a resistor **186**.

[0160] Yet another embodiment for a photoelectrochemical cell for the electrolysis of water, may comprise a container, an aqueous electrolyte in the container, wherein the pH of the electrolyte is neutral or below, a photoanode mounted in the container and in contact with the electrolyte, wherein the first electrode comprises a photoactive electrode, metal ionic species and anionic species, the metal ionic species and the anionic species defining a substantially non-crystalline composition and have an equilibrium constant, K_{sp} , between about 10^{-3} and 10^{-10} when the metal ionic species is in an oxidation state of (n) and have a K_{sp} less than about 10^{-10} when the metal ionic species is in an oxidation state of (n+x), an electrode (or second photoactive) mounted in the container and in contact with the electrolyte, wherein the electrode is biased negatively with respect to the photoanode, and means for connecting the photoanode and the electrode. In this embodiment, when a voltage is applied between the photoanode and the electrode, gaseous hydrogen may be evolved at the electrode and gaseous oxygen may be produced at the photoanode.

[0161] The performance of a photoanode of a device may be measured by current density (e.g., geometric and/or total current density), wherein the current density is a measure of the density of flow of a conserved charge. For example, the current density is the electric current per unit area of cross section. In some cases, the current density (e.g., geometric current density and/or total current density, as described herein) of a photoanode as described herein is greater than about 0.1 mA/cm², greater than about 1 mA/cm², greater than about 5 mA/cm², greater than about 10 mA/cm², greater than about 20 mA/cm², greater than about 25 mA/cm², greater than about 30 mA/cm², greater than about 50 mA/cm², greater than about 100 mA/cm², greater than about 200 mA/cm², and the like.

[0162] In some embodiments, the current density can be described as the geometric current density. The geometric current density, as used herein, is current divided by the external surface area of the photoanode. The external surface area of a photoanode will be understood by those of ordinary skill in the art and refers to the surface defining the outer boundary of the photoanode, for example, the area that may be measured by a macroscopic measuring tool (e.g., a ruler) and does not include the internal surface area (e.g., area within pores of a porous material such as a foam, or surface area of those fibers of a mesh that are contained within the mesh and do not define the outer boundary, etc.).

[0163] In some cases, the current density can be described as the total current density. Total current density, as used herein, is the current density divided by essentially the total

surface area (e.g., the total surface area including all pores, fibers etc.) of the photoanode. In some cases, the total current density may be approximately equal to the geometric current density (e.g., in cases where the photoanode is not porous and the total surface area is approximately equal to the geometric surface area).

[0164] In some embodiments, a device and/or photoanode as described herein is capable of producing at least about 1 umol (micromole), at least about 5 umol, at least about 10 umol, at least about 20 umol, at least about 50 umol, at least about 100 umol, at least about 200 umol, at least about 500 umol, at least about 1000 umol oxygen and/or hydrogen, or more, per cm² at the photoanode at which oxygen production and/or hydrogen production occurs, respectively, per hour. The area of the photoanode may be the geometric surface area or the total surface area, as described herein.

[0165] The devices and methods as described herein, in some cases, may proceed at about ambient conditions. Ambient conditions define the temperature and pressure relating to the device and/or method. For example, ambient conditions may be defined by a temperature of about 25° C. and a pressure of about 1.0 atmosphere (e.g., 1 atm, 14 psi). In some cases, the conditions may be essentially ambient. Non-limiting examples of essentially ambient temperature ranges include between about 0° C. and about 40° C., between about 5° C. and about 35° C., between about 10° C. and about 30° C., between about 15° C. and about 25° C., at about 20° C., at about 25° C., and the like. Non-limiting examples of essentially ambient pressure ranges include between about 0.5 atm and about 1.5 atm, between about 0.7 atm and about 1.3 atm, between about 0.8 and about 1.2 atm, between about 0.9 atm and about 1.1 atm, and the like. In a particular case, the pressure may be about 1.0 atm. Ambient or essentially ambient conditions can be used in conjunction with any of the devices, compositions, catalytic materials, and/or methods described herein, in conjunction with any conditions (for example, conditions of pH, etc.).

[0166] In some cases, the devices and/or methods as described herein may proceed at temperatures above ambient temperature. For example, a device and/or method may be operated at temperatures greater than about 30° C., greater than about 40° C., greater than about 50° C., greater than about 60° C., greater than about 70° C., greater than about 80° C., greater than about 90° C., greater than about 100° C., greater than about 120° C., greater than about 150° C., greater than about 200° C., or greater. Efficiencies can be increased, in some instances, at temperatures higher than ambient. The temperature of the device may be selected such that the water provided and/or formed is in a gaseous state (e.g., at temperatures greater than about 100° C.). In other cases, devices and/or methods as described herein may proceed at temperatures below ambient temperature. For example, a device and/or method may be operated at temperatures less than about 20° C., less than about 10° C., less than about 0° C., less than about -10° C., less than about -20° C., less than about -30° C., less than about -40° C., less than about -50° C., less than about -60° C., less than about -70° C. or the like. In some instances, the temperature of the device and/or method may be affected by an external temperature source (e.g., a heating and/or cooling coil, infrared light, refrigeration, etc.). In other instances, however, the temperature of the device and/or method may be affected by internal processes, for example, exothermic and/or endothermic reactions, etc. In some cases, the device and/or method may be operated at approximately

the same temperature throughout the use of the device and/or method. In other cases, the temperature may be changed at least once and/or gradually during the use of the device and/or method. In a particular embodiment, the temperature of the device may be elevated during times when the device is used in conjugation with sunlight or other radiative power sources.

[0167] In some embodiments, the water provided and/or formed during use of a method and/or device as described herein may be in a gaseous state (e.g., steam). Those of ordinary skill in the art can apply known electrochemical techniques carried out with steam, in some cases, without undue experimentation. As an exemplary embodiment, water may be provided in a gaseous state to an electrochemical device (e.g., high-temperature electrolysis or steam electrolysis) comprising a photoanode. In some cases, the gaseous water may be produced by a device or system which inherently produces steam (e.g., a nuclear power plant). Without wishing to be bound by theory, in some cases, providing water in a gaseous state may allow for the electrolysis to proceed more efficiently as compared to a similar device when provided water in a liquid state. This may be due to the higher input energy of the water vapor. In some instances, the gaseous water provided may comprise other gases (e.g., hydrogen gas, nitrogen gas, etc.).

[0168] Individual aspects of the overall electrochemistry and/or chemistry involved in electrochemical devices such as those described herein are generally known, and not all will be described in detail herein. It is to be understood that the specific electrochemical devices described herein are exemplary only, and the components, connections, and techniques as described herein can be applied to virtually any suitable electrochemical device including those with a variety of solid, liquid, and/or gaseous fuels, and a variety of photoanodes, electrodes, photocathodes, and/or electrolytes, which may be liquid or solid under operating conditions (where feasible; generally, for adjacent components one will be solid and one will be liquid if any are liquids). It is also to be understood that photoelectrochemical device unit arrangements discussed are merely examples of photoelectrochemical devices that can make use of photoanodes as described herein. Many structural arrangements other than those disclosed herein, which make use of and are enabled by the present invention, will be apparent to those of ordinary skill in the art.

[0169] A photoelectrochemical device accordingly may be combined with additional electrochemical devices (e.g., a fuel cell, an electrolytic device, etc.) to form a larger device or system. In some embodiments, this may take the form of a stack of units or devices. Where more than one electrochemical device is combined, the devices may all be devices according to an embodiment the present invention, or one or more devices according to an embodiment the present invention may be combined with other photoelectrochemical devices, such as a fuel cell. It is to be understood that where this terminology is used, any suitable electrochemical device, which those of ordinary skill in the art would recognize could function in accordance with the systems and techniques as described herein can be substituted.

[0170] Water may be provided to the systems, devices, photoanodes, and/or for the methods provided herein, using any suitable source. In some cases, the water is provided from a substantially pure water source (e.g., distilled water, deionized water, chemical grade water, etc.). In some cases, the water may be bottled water. In some cases, the water is provided from a natural and/or impure water source (e.g., tap

water, lake water, ocean water, rain water, lake water, pond water, sea water, potable water, brackish water, industrial process water, etc.). In some cases, although it need not be, the water is not purified prior to use (e.g., before being provided to the system/photoanode for electrolysis). In some instances, the water may be filtered to remove particulates and/or other impurities prior to use. In some embodiments, the water that is electrolyzed to produce oxygen gas (e.g., using a photoanode and/or device as described here) may be substantially pure. The purity of the water may be determined using one or more methods known to those of ordinary skill in the art, for example, resistivity, carbon content (e.g., through use of a total organic carbon analyzer), UV absorbance, oxygen-absorbance test, limulus ameobocyte lysate test, etc. In some embodiments, the water may contain at least one impurity. In some embodiments, the at least one impurity may be substantially non-participative in the catalytic reaction. That is, the at least one impurity does not participate in aspects of the catalytic cycle and/or regeneration mechanism. The at least one impurity may be solid (e.g., particulate matter), a liquid, and/or a gas. In some cases, the impurity may be solubilized and/or dissolved. For example, an impurity may comprise ionic species. In some cases, an impurity may be an impurity which may generally be present in a water source (e.g., tap water, non-potable water, potable water, sea water, etc.). In a particular embodiment, the water source may be sea water and one of the impurities may be chloride ions, as described herein. In some cases, an impurity may comprise a metal such as a metal element (including heavy metals), a metal ion, a compound comprising at least one metal, an ionic species comprising a metal, etc. For example, an impurity comprising metal may comprise an alkaline earth metal, an alkali metal, a transition metal, or the like. Specific non-limiting examples of metals include lithium, sodium, magnesium, titanium, vanadium, chromium, manganese, iron, cobalt, nickel, copper, zinc, potassium, mercury, lead, barium, etc. In some instances, an impurity comprising a metal may be the same or different than the metal comprised in the metal ionic species of a catalytic material as described herein. In some cases, the impurity may comprise organic materials, for example, small organic molecules (e.g., bisphenol A, trimethylbenzene, dioxane, nitrophenol, etc.), microorganisms (such as bacteria (e.g., *E. coli*, coliform, etc.), microbes, fungi, algae, etc.), other biological materials, pharmaceutical compounds (e.g., drugs, decomposition products from drugs), herbicides, pyrogens, pesticides, proteins, radioactive compounds, inorganic compounds (e.g., compounds comprising boron, silicon, sulfur, nitrogen, cyanide, phosphorus, arsenic, sodium, etc.; carbon dioxide, silicates (e.g., H_4SiO_4), ferrous and ferric iron compounds, chlorides, aluminum, phosphates, nitrates, etc.), dissolved gases, suspended particles (e.g., colloids), or the like. In some cases, an impurity may be a gas, for example, carbon monoxide, ammonia, carbon dioxide, oxygen gas, and/or hydrogen gas. In some cases, the gas impurity may be dissolved in the water. In some cases, a photoanode may be capable of operating at approximately the same, at greater than about 95%, at greater than about 90%, at greater than about 80%, at greater than about 70%, at greater than about 60%, at greater than about 50%, or the like, of the activity level using water containing at least one impurity versus the activity using water that does not substantially contain the impurity under essentially identical conditions. In some cases, a photoanode may catalytically produce oxygen from water containing at least one impurity

such that less than about 5 mol %, less than about 3 mol %, less than about 2 mol %, less than about 1 mol %, less than about 0.5 mol %, less than about 0.1 mol %, less than about 0.01 mol % of the products produced comprise any portion of the at least one impurity.

[0171] In some cases, an impurity may be present in the water in an amount greater than about 1 ppt, greater than about 10 ppt, greater than about 100 ppt, greater than about 1 ppb, greater than about 10 ppb, greater than about 100 ppb, greater than about 1 ppm, greater than about 10 ppm, greater than about 100 ppm, greater than about 1000 ppm, or greater. In other cases, an impurity may be present in the water in an amount less than about 1000 ppm, less than about 100 ppm, less than about 10 ppm, less than about 1 ppm, less than about 100 ppb, less than about 10 ppb, less than about 1 ppb, less than about 100 ppt, less than about 10 ppt, less than about 1 ppt, or the like. In some cases, the water may contain at least one impurity, at least two impurities, at least three impurities, at least five impurities, at least ten impurities, at least fifteen impurities, at least twenty impurities, or greater. In some cases, the amount of impurity may increase or decrease during operation of the photoanode and/or device. That is, an impurity may be formed during use of the photoanode and/or device. For example, in some cases, the impurity may be a gas (e.g., oxygen gas and/or hydrogen gas) formed during the electrolysis of water. Thus, in some cases, the water may contain less than about 1000 ppm, less than about 100 ppm, less than about 10 ppm, less than about 1 ppm, less than about 100 ppb, less than about 10 ppb, less than about 1 ppb, less than about 100 ppt, less than about 10 ppt, less than about 1 ppt, or the like, prior to operation of the photoanode and/or device.

[0172] In some embodiments, the at least one impurity may be an ionic species. In some cases, when the water contains at least one ionic species, the water purity may be determined, at least in part, by measuring the resistivity of the water. The theoretical resistivity of water at 25° C. is about 18.2 M Ω ·cm. The resistivity of water that is not substantially pure may be less than about 18 M Ω ·cm, less than about 17 M Ω ·cm, less than about 16 M Ω ·cm, less than about 15 M Ω ·cm, less than about 12 M Ω ·cm, less than about 10 M Ω ·cm, less than about 5 M Ω ·cm, less than about 3 M Ω ·cm, less than about 2 M Ω ·cm, less than about 1 M Ω ·cm, less than about 0.5 M Ω ·cm, less than about 0.1 M Ω ·cm, less than about 0.01 M Ω ·cm, less than about 1000 Ω ·cm, less than about 500 Ω ·cm, less than about 100 Ω ·cm, less than about 10 Ω ·cm, or less. In some cases, the resistivity of the water may be between about 10 M Ω ·cm and about 1 Ω ·cm, between about 1 M Ω ·cm and about 10 Ω ·cm, between about 0.1 M Ω ·cm and about 100 Ω ·cm, between about 0.01 M Ω ·cm and about 1000 Ω ·cm, between about 10,000 Ω ·cm and about 1,000 Ω ·cm, between about 10,000 Ω ·cm and about 100 Ω ·cm, between about 1,000 and about 1 Ω ·cm, between about 1,000 and about 10 Ω ·cm, and the like. In some cases, when the water source is tap water, the resistivity of the water may be between about 10,000 Ω ·cm and about 1,000 Ω ·cm. In some cases, when the water source is sea water, the resistivity of the water may be between about 1,000 Ω ·cm and about 10 Ω ·cm. In some instances, where the water may be taken from an impure source and purified prior to use, the water may be purified in a manner which does not resistivity of the water by a factor of more than about 5%, about 10%, about 20%, about 25%,

about 30%, about 50%, or the like. Those of ordinary skill in the art will be aware of methods to determine the resistivity of water.

[0173] In some cases, where the water is obtained from an impure water source and/or has a resistivity of less than about 16 M Ω -cm the water may be purified (e.g., filtered) in a manner that changes its resistivity by a factor of less than about 50%, less than about 30%, less than about 25%, less than about 20%, less than about 15%, less than about 10%, less than about 5%, or less, after being drawn from the source prior to use in the electrolysis.

[0174] In some embodiments, the water may contain halide ions (e.g., fluoride, chloride, bromide, iodide), for example, such that a photoanode may be used for the desalination of sea water. In some cases, the halide ions might not be oxidized (e.g., to form halogen gas such as Cl₂) during the catalytic production of oxygen from water. Without wishing to be bound by theory, halide ions (or other anionic species) that might not be incorporated in the catalytic material (e.g., within the lattice of the catalytic material) might not be oxidized during the catalytic formation of oxygen from water. This may be because the halide ions might not readily form bonds with the metal ionic species, and therefore, may only have access to outer sphere mechanism for oxidation. In some instances, oxidation of halide ions by an outer sphere mechanism may be not kinetically favorable. In some cases, a photoanode may catalytically produce oxygen from water comprising halide ions such that less than about 5 mol %, less than about 3 mol %, less than about 2 mol %, less than about 1 mol %, less than about 0.5 mol %, less than about 0.1 mol %, less than about 0.01 mol % of the gases evolved comprise oxidized halide species. In some embodiments, the impurity is sodium chloride.

[0175] In some cases, under catalytic condition, halide ions (or other impurities) might not associate with a catalytic material and/or with metal ionic species. In some instances, a complex comprising a halide ion and a metal ionic species may be substantially soluble such that the complex does not form a catalytic material and/or associate with the photoactive electrode and/or photoanode. In some cases, the catalytic material may comprise less than about 5 mol %, less than about 3 mol %, less than about 2 mol %, less than about 1 mol %, less than about 0.5 mol %, less than about 0.1 mol %, less than about 0.01 mol % of the halide ion impurities.

[0176] In some cases, the rate of oxidation of water may dominate over the rate of oxidation of halide ions (or other impurities) due to various factors including thermodynamics, solubility, and the like. For example, the binding affinity of a metal ionic species for an anionic species may be substantially greater than the binding affinity of the metal ionic species for a halide ion, such that the coordination sphere of the metal ionic species may be substantially occupied by the anionic species. In other cases, the halide ions might not be incorporated into the lattice of a catalytic material (e.g., as part of the lattice or within the interstitial holes of the lattice) due to the size of the halide ion (e.g., the halide is too large or too small to be incorporated into the lattice of the catalytic material). Those of ordinary skill in the art will be able to determine if a photoanode as described herein is able to catalytically produce oxygen using water containing halide ions, for example, by monitoring the production of halogen gas (or species comprising oxidized halide ions) using suitable techniques, for example, mass spectrometry.

[0177] Various components of the invention, such as the photoanode, electrode, photocathode, power source, electrolyte, separator, container, circuitry, insulating material, gate electrode, etc. can be fabricated by those of ordinary skill in the art from any of a variety of components, as well as those described in any of those patent applications described herein. Components of the invention can be molded, machined, extruded, pressed, isopressed, infiltrated, coated, in green or fired states, or formed by any other suitable technique. Those of ordinary skill in the art are readily aware of techniques for forming components of devices herein. In some cases, components (e.g., photoanodes, electrodes, electrolyte, electrical connectors, wires, etc.) of a device may be selected as to minimize the ohmic resistances of the device. This may aid in achieving the maximum energy conversion efficiency possible for a selected device.

[0178] While electromagnetic radiation sources are described herein, it should be understood that electromagnetic radiation may be provided in any suitable arrangement or using any suitable source, and may depend on the arrangement and components of the photoelectrochemical device. In some cases, electromagnetic radiation may be provided to one or more surface and/or components of a photoelectrochemical device. For example, electromagnetic radiation may be provided directly to a catalytic material (e.g., light is shone on the catalytic material), or may be provided indirectly, for example, through the backside of the catalytic material (e.g., light is shone through one or more other materials, including, but not limited to, the photoactive electrode). Those of ordinary skill in the art will be able to determine the portions of a device to be exposed to electromagnetic radiation.

[0179] In some cases, the device may comprise a light management system and/or solar concentrator, which are capable of focusing electromagnetic radiation and/or solar energy. Generally, light management systems or solar concentrators may receive electromagnetic radiation and/or solar energy over a first surface area and direct the received radiation to a second, smaller, surface area. Light management systems and solar concentrators will be known to those of ordinary skill in the art and may comprise, for example, magnifying lenses, parabolic mirrors, and/or Fresnel lenses for focusing incoming light and/or solar energy. In some cases, the light management system or solar collector may collect and waveguide the light to an area or surface of the photoelectrochemical device, for example, a surface associated with the catalytic material, a photoactive electrode, a photoanode, a photocathode, etc.

[0180] In some cases, a device may be portable. That is, the device may be of such size that it is small enough that it is movable. In some embodiments, a device of the present invention is portable and can be employed at or near a desired location (e.g., water supply location, field location, etc.). For example, the device may be transported and/or stored at a specific location. In some case, the device may be equipped with straps or other components (e.g., wheels) such that the device may be carried or transported from a first location to a second location. Those of ordinary skill in the art will be able to identify a portable device. For instance, the portable device may have a weight less than about 25 kg, less than about 20 kg, less than about 15 kg, less than about 1 kg, less than about 8 kg, less than about 7 kg, less than about 6 kg, less than about 5 kg, less than about 4 kg, less than about 3 kg, less than about 2 kg, less than about 1 kg, and the like, and/or have a largest dimension that is no more than 50 cm, less than about 40 cm,

less than about 30 cm, less than about 20 cm, less than about 10 cm, and the like. The weight and/or dimensions of the device typically may or might not include components associated with the device (e.g., water source, water source reservoir, oxygen and/or hydrogen storage containers, etc.).

[0181] An electrolyte, as known to those of ordinary skill in the art is any substance containing free ions that is capable of functioning as an ionically conductive medium. In some cases, an electrolyte may comprise water, which may act as the water source. The electrolyte may be a liquid, a gel, and/or solid. The electrolyte may also comprise methanol, ethanol, sulfuric acid, methanesulfonic acid, nitric acid, mixtures of HCl, organic acids like acetic acid, etc. In some cases, the electrolyte comprises mixtures of solvents, such as water, organic solvents, amines and the like. In some cases, the pH of the electrolyte may be about neutral. That is, the pH of the electrolyte may be between about 5.5 and about 8.5, between about 6.0 and about 8.0, about 6.5 about 7.5, and/or the pH is about 7.0. In a particular case, the pH is about 7.0. In other cases, the pH of the electrolyte is about neutral or acidic. In these cases, the pH may range from about 0 to about 8, about 1 to about 8, about 2 to about 8, about 3 to about 8, about 4 to about 8, about 5 to about 8, about 0 to about 7.5, about 1 to about 7.5, about 2 to about 7.5, about 3 to about 7.5, about 4 to about 7.5, about 5 to about 7.5. In yet other cases, the pH may be between about 6 and about 10, about 6 and about 11, about 7 and about 14, about 2 and about 12, and the like. In a specific embodiment, the pH is between about 6 and about 8, between about 5.5 and about 8.5, between about 5.5 and about 9.5, between about 5 and about 9, between about 3 and about 11, between about 4 and about 10, or any other combination thereof. In some cases, when the electrolyte is a solid, the electrolyte may comprise a solid polymer electrolyte. The solid polymer electrolyte may serve as a solid electrolyte that conducts protons and separate the gases produces and or utilized in the electrochemical cell. Non-limiting examples of a solid polymer electrolyte are polyethylene oxide, polyacrylonitrile, and commercially available NAFION.

[0182] In some cases, the electrolyte is used to selectively transport one or more ionic species. In some embodiments, the electrolyte(s) are at least one of oxygen ion conducting membranes, proton conductors, carbonate (CO_3^{2-}) conductors, OH^- conductors, and/or mixtures thereof. In some cases, the electrolyte(s) are at least one of cubic fluorite structures, doped cubic fluorites, proton-exchange polymers, proton-exchange ceramics, and mixtures thereof. Further, oxygen-ion conducting oxides that may be used as the electrolyte(s) include doped ceria compounds such as gadolinium-doped ceria ($\text{Gd}_{1-x}\text{Ce}_x\text{O}_{2-d}$) or samarium-doped ceria ($\text{Sm}_{1-x}\text{Ce}_x\text{O}_{2-d}$), doped zirconia compounds such as yttrium-doped zirconia ($\text{Y}_{1-x}\text{Zr}_x\text{O}_{2-d}$) or scandium-doped zirconia ($\text{Sc}_{1-x}\text{Zr}_x\text{O}_{2-d}$), perovskite materials such as $\text{La}_{1-x}\text{Sr}_x\text{Ga}_{1-y}\text{Mg}_y\text{O}_{3-d}$, yttria-stabilized bismuth oxide, and/or mixtures thereof. Examples of proton conducting oxides that may be used as electrolyte(s) include, but are not limited to, undoped and yttrium-doped BaZrO_{3-d} , BaCeO_{3-d} , and SrCeO_{3-d} as well as $\text{La}_{1-x}\text{Sr}_x\text{NbO}_{3-d}$.

[0183] In some embodiments, the electrolyte may comprise an ionically conductive material. In some embodiments, the ionically conductive material may comprise the anionic species comprised in the catalytic material on at least one photoanode. The presence of the anionic species in the electrolyte, during use of the photoanode comprising a catalytic material, may shift the dynamic equilibrium towards the association of the anionic species and/or metal ionic species with the photoanode, as described herein. Non-limiting examples of other ionically conductive materials include metal oxy-

compounds, soluble inorganic and/or organic salts (e.g., sodium or potassium chloride, sodium sulfate, quaternary ammonium hydroxides, etc.).

[0184] In some cases, the electrolyte may comprise additives. For example, the additive may be an anionic species (e.g., as comprised in the catalytic material associated with a photoactive electrode). For example, a photoanode used in a device may comprise a photoactive electrode and a catalytic material comprising at least one anionic species and at least one metal ionic species. The electrolyte may comprise the at least one anionic species. In some cases, the electrolyte can comprise an anionic species which is different from the at least one anionic species comprised in the catalytic material. For example, the catalytic material may comprise phosphate anions and the electrolyte may comprise borate anions. In some cases, when the additive is an anionic species, the electrolyte may comprise counter cations (e.g., when the anionic species is added as a complex, a salt, etc.). The anionic species may be good proton-accepting species. In some cases, the additive may be a good proton-accepting species which is not anionic (e.g., is a neutral base). Non-limiting examples of good proton-accepting species which are neutral include pyridine, imidazole, and the like.

[0185] In some cases, the electrolyte may be recirculated in the electrochemical device. That is, a device may be provided which is able to move the electrolyte in the electrochemical device. Movement of the electrolyte in the electrochemical device may help decrease the boundary layer of the electrolyte. The boundary layer is the layer of fluid in the immediate vicinity of an electrode and/or photoanode. In general, the extent to which a boundary layer exists is a function of the flow velocity of the liquid in a solution. Therefore, if the fluid is stagnant, the boundary layer may be much larger than if the fluid was flowing. Therefore, movement of the electrolyte in the photoelectrochemical device may decrease the boundary layer and improve the efficiency of the device.

[0186] In most embodiments, a device may comprise at least one photoanode as described herein (e.g., comprising a photoactive electrode and a catalytic material). In some instances, the device can additionally comprise at least one electrode and/or photocathode. In general, an electrode may be any material that is substantially electrically conductive. The electrode may be transparent, semi-transparent, semi-opaque, and/or opaque. The electrode may be a solid, semi-porous or porous. Non-limiting examples of electrodes include indium tin oxide (ITO), fluorine tin oxide (FTO), glassy carbon, metals, lithium-containing compounds, metal oxides (e.g., platinum oxide, nickel oxide), graphite, nickel mesh, carbon mesh, and the like. Non-limiting examples of suitable metals include gold, copper, silver, platinum, nickel, cadmium, tin, and the like. In some instances, the electrode may comprise nickel (e.g., nickel foam or nickel mesh). Nickel foam and nickel mesh materials will be known to those of ordinary skill in the art and may be purchase from commercial sources. Nickel mesh usually refers to woven nickel fibers. Nickel foam generally refers to a material of non-trivial thickness (e.g., about 2 mm) comprising a plurality of holes and/or pores. In some cases, nickel foam may be an open-cell, metallic structure based on the structure of an open-cell polymer foam, wherein nickel metal is coated onto the polymer foam. The electrodes may also be any other metals and/or non-metals known to those of ordinary skill in the art as conductive (e.g., ceramics). The electrodes may also be photoactive electrodes used in photoelectrochemical cells. The electrode may be of any size or shape. Non-limiting examples of shapes include sheets, cubes, cylinders, hollow tubes, spheres, and the like. The electrode may be of any size.

Additionally, the electrode may comprise a means to connect the electrode and to another electrode, a power source and/or another electrical device.

[0187] Various electrical components of device may be in electrical communication with at least one other electrical component by a means for connecting. A means for connecting may be any material that allows the flow of electricity to occur between a first component and a second component. A non-limiting example of a means for connecting two electrical components is a wire comprising a conductive material (e.g., copper, silver, etc.). In some cases, the device may also comprise electrical connectors between two or more components (e.g., a wire and an electrode and/or photoanode). In some cases, a wire, electrical connector, or other means for connecting may be selected such that the resistance of the material is low. In some cases, the resistances may be substantially less than the resistance of the electrodes, photoanodes, and/or electrolyte of the device.

[0188] In some embodiments, a power source may be provided to supply DC or AC voltage to an electrochemical device. Non-limiting examples include batteries, power grids, regenerative power supplies (e.g., wind power generators, photovoltaic cells, tidal energy generators), generators, and the like. The power source may comprise one or more of such power supplies (e.g., batteries and a photovoltaic cell).

[0189] In some embodiment, a device may comprise a power management system, which may be any suitable controller device, such as a computer or microprocessor, and may contain logic circuitry which decides how to route the power streams. The power management system may be able to direct the energy provided from a power source or the energy produced by the electrochemical device to the end point, for example, another device. It is also possible to feed electrical energy to a power source and/or to consumer devices (e.g., cellular phone, television).

[0190] In some cases, electrochemical devices may comprise a separating membrane. The separating membranes or separators for the photoelectrochemical device may be made of suitable material, for example, a plastic film. Non-limiting examples of plastic films included include polyamide, polyolefin resins, polyester resins, polyurethane resin, or acrylic resin and containing lithium carbonate, or potassium hydroxide, or sodium-potassium peroxide dispersed therein.

[0191] A container may be any receptacle, such as a carton, can, or jar, in which components of an electrochemical device may be held or carried. A container may be fabricated using any known techniques or materials, as will be known to those of ordinary skill in the art. For example, in some instances, the container may be fabricated from glass, polymer, metal, and the like. The container may have any shape or size, providing it can contain the components of the electrochemical device. Components of the electrochemical device may be mounted in the container. That is, a component (e.g., an electrode) may be associated with the container such that it is immobilized with respect to the container, and in some cases, is supported by the container. A component may be mounted to the container using any common method and/or material known to those skilled in the art (e.g., screws, wires, adhesive, etc). The component may or might not physically contact the container. In some cases, an electrode may be mounted in the container such that the electrode is not in contact with the container, but is mounted in the container such that it is suspended in the container.

[0192] Where the catalytic material, photoanode, and/or electrode of the invention is used in connection with an electrochemical device such as a fuel cell, any suitable fuels, oxidizers, and/or reactant product may be provided to and/or

produced by electrochemical devices. In some embodiments, the photoelectrochemical device may produce a fuel (e.g., hydrogen). In a particular embodiment, in addition to oxygen, hydrogen is produced by the photoelectrochemical device. In other embodiments, the photoelectrochemical device may produce fuel such as a hydrocarbon (e.g., methane, ethane, propane) and/or a product from the reduction of carbon monoxide or carbon dioxide. Other fuels and oxidants can be used to produce oxygen and a second product, as will be known to those of ordinary skill in the art.

[0193] Protons may be provided to the devices described herein using any suitable proton source, as will be known to those of ordinary skill in the art. The proton source may be any molecule or chemical which is capable of supplying a proton, for example, H^+ , H_3O^+ , NH_4^+ , etc. A hydrogen source (e.g., for use as a fuel in a fuel cell) may be any substance, compound, or solution including hydrogen such as, for example, hydrogen gas, a hydrogen rich gas, natural gas, etc. The oxygen gas provided to a device may or may not be substantially pure. For example, in some cases, any substance, compound or solution including oxygen may be provided, such as, an oxygen rich gas, air, etc.

[0194] The fuel may be supplied to and/or removed from a device and/or system using a fuel transport device. The nature of the fuel delivery may vary with the type of fuel and/or the type of device. For example, solid, liquid, and gaseous fuels may all be introduced in different manners. The fuel transport device may be a gas or liquid conduit such as a pipe or hose which delivers or removes fuel, such as hydrogen gas or methane, from the electrochemical device and/or from the fuel storage device. Alternatively, the device may comprise a movable gas or liquid storage container, such as a gas or liquid tank, which may be physically removed from the device after the container is filled with fuel. If the device comprises a container, then the device may be used as both the fuel storage device while it remains attached to the electrochemical device, and as a container to remove fuel from the photoelectrochemical device. Those of ordinary skill in the art will be aware of systems, methods, and/or techniques for supplying and/or removing fuel from a device or system.

[0195] A variety of definitions are now provided which may aid in understanding various aspects of the invention.

[0196] In general, the term “aliphatic,” as used herein, includes both saturated and unsaturated, straight chain (i.e., unbranched) or branched aliphatic hydrocarbons, which are optionally substituted with one or more functional groups, as defined below. As will be appreciated by one of ordinary skill in the art, “aliphatic” is intended herein to include, but is not limited to, alkyl, alkenyl, alkynyl moieties. Illustrative aliphatic groups thus include, but are not limited to, for example, methyl, ethyl, n-propyl, isopropyl, allyl, n-butyl, sec-butyl, isobutyl, tert-butyl, n-pentyl, sec-pentyl, isopentyl, tert-pentyl, n-hexyl, sec-hexyl, moieties and the like, which again, may bear one or more substituents, as previously defined.

[0197] As used herein, the term “alkyl” is given its ordinary meaning in the art and may include saturated aliphatic groups, including straight-chain alkyl groups, branched-chain alkyl groups, cycloalkyl (alicyclic) groups, alkyl substituted cycloalkyl groups, and cycloalkyl substituted alkyl groups. An analogous convention applies to other generic terms such as “alkenyl,” “alkynyl,” and the like. Furthermore, as used herein, the terms “alkyl,” “alkenyl,” “alkynyl,” and the like encompass both substituted and unsubstituted groups.

[0198] In some embodiments, a straight chain or branched chain alkyl may have 30 or fewer carbon atoms in its backbone, and, in some cases, 20 or fewer. In some embodiments, a straight chain or branched chain alkyl has 12 or fewer

carbon atoms in its backbone (e.g., C₁-C₁₂ for straight chain, C₃-C₁₂ for branched chain), has 6 or fewer, or has 4 or fewer. Likewise, cycloalkyls have from 3-10 carbon atoms in their ring structure or from 5, 6 or 7 carbons in the ring structure. Examples of alkyl groups include, but are not limited to, methyl, ethyl, propyl, isopropyl, cyclopropyl, butyl, isobutyl, tert-butyl, cyclobutyl, hexyl, cyclohexyl, and the like. In some cases, the alkyl group might not be cyclic. Examples of non-cyclic alkyl include, but are not limited to, methyl, ethyl, propyl, isopropyl, n-butyl, tert-butyl, n-pentyl, neopentyl, n-hexyl, n-heptyl, n-octyl, n-decyl, n-undecyl, and dodecyl.

[0199] The terms “alkenyl” and “alkynyl” refer to unsaturated aliphatic groups analogous in length and possible substitution to the alkyls described above, but that contain at least one double or triple bond respectively. Alkenyl groups include, but are not limited to, for example, ethenyl, propenyl, butenyl, 1-methyl-2-buten-1-yl, and the like. Non-limiting examples of alkynyl groups include ethynyl, 2-propynyl (propargyl), 1-propynyl, and the like.

[0200] The terms “heteroalkenyl” and “heteroalkynyl” refer to unsaturated aliphatic groups analogous in length and possible substitution to the heteroalkyls described above, but that contain at least one double or triple bond respectively.

[0201] As used herein, the term “halogen” or “halide” designates —F, —Cl, —Br, or I.

[0202] The term “aryl” refers to aromatic carbocyclic groups, optionally substituted, having a single ring (e.g., phenyl), multiple rings (e.g., biphenyl), or multiple fused rings in which at least one is aromatic (e.g., 1,2,3,4-tetrahydronaphthyl, naphthyl, anthryl, or phenanthryl). That is, at least one ring may have a conjugated Pi electron system, while other, adjoining rings can be cycloalkyls, cycloalkenyls, cycloalkynyls, aryls, and/or heterocyclyls. The aryl group may be optionally substituted, as described herein. “Carbocyclic aryl groups” refer to aryl groups wherein the ring atoms on the aromatic ring are carbon atoms. Carbocyclic aryl groups include monocyclic carbocyclic aryl groups and polycyclic or fused compounds (e.g., two or more adjacent ring atoms are common to two adjoining rings) such as naphthyl group. Non-limiting examples of aryl groups include phenyl, naphthyl, tetrahydronaphthyl, indanyl, indenyl and the like.

[0203] The terms “heteroaryl” refers to aryl groups comprising at least one heteroatom as a ring atom, such as a heterocycle. Non-limiting examples of heteroaryl groups include pyridyl, pyrazinyl, pyrimidinyl, pyrrolyl, pyrazolyl, imidazolyl, thiazolyl, oxazolyl, isooxazolyl, thiadiazolyl, oxadiazolyl, thiophenyl, furanyl, quinolinyl, isoquinolinyl, and the like.

[0204] It will also be appreciated that aryl and heteroaryl moieties, as defined herein, may be attached via an aliphatic, alicyclic, heteroaliphatic, heteroalicyclic, alkyl or heteroalkyl moiety and thus also include -(aliphatic)aryl, -(heteroaliphatic)aryl, -(aliphatic)heteroaryl, -(heteroaliphatic)heteroaryl, -(alkyl)aryl, -(heteroalkyl)aryl, -(heteroalkyl)aryl, and -(heteroalkyl)-heteroaryl moieties. Thus, as used herein, the phrases “aryl or heteroaryl” and “aryl, heteroaryl, (aliphatic)aryl, -(heteroaliphatic)aryl, -(aliphatic)heteroaryl, -(heteroaliphatic)heteroaryl, -(alkyl)aryl, -(heteroalkyl)aryl, -(heteroalkyl)aryl, and -(heteroalkyl)heteroaryl” are interchangeable.

[0205] Any of the above groups may be optionally substituted. As used herein, the term “substituted” is contemplated to include all permissible substituents of organic compounds, “permissible” being in the context of the chemical rules of valence known to those of ordinary skill in the art. It will be understood that “substituted” also includes that the substitution results in a stable compound, e.g., which does not spon-

taneously undergo transformation such as by rearrangement, cyclization, elimination, etc. In some cases, “substituted” may generally refer to replacement of a hydrogen with a substituent as described herein. However, “substituted,” as used herein, does not encompass replacement and/or alteration of a key functional group by which a molecule is identified, e.g., such that the “substituted” functional group becomes, through substitution, a different functional group. For example, a “substituted phenyl group” must still comprise the phenyl moiety and can not be modified by substitution, in this definition, to become, e.g., a pyridine ring. In a broad aspect, the permissible substituents include acyclic and cyclic, branched and unbranched, carbocyclic and heterocyclic, aromatic and nonaromatic substituents of organic compounds. Illustrative substituents include, for example, those described herein. The permissible substituents can be one or more and the same or different for appropriate organic compounds. For purposes of this invention, the heteroatoms such as nitrogen may have hydrogen substituents and/or any permissible substituents of organic compounds described herein which satisfy the valencies of the heteroatoms.

[0206] Examples of substituents include, but are not limited to, aliphatic, alicyclic, heteroaliphatic, heteroalicyclic, halogen, azide, alkyl, aralkyl, alkenyl, alkynyl, cycloalkyl, hydroxyl, alkoxy, amino, nitro, sulfhydryl, imino, amido, phosphonate, phosphinate, carbonyl, carboxyl, silyl, ether, alkylthio, heteroalkylthio, heteroarylthio, sulfonyl, sulfonamido, ketone, aldehyde, ester, heterocyclyl, aromatic or heteroaromatic moieties, —CF₃, —CN, aryl, aryloxy, perhaloalkoxy, aralkoxy, heteroaryl, heteroaryloxy, heteroarylalkyl, heteroaralkoxy, azido, amino, halide, alkylthio, oxo, acylalkyl, carboxy esters, -carboxamido, acyloxy, aminoalkyl, alkylaminoaryl, alkylaryl, alkylaminoalkyl, alkoxyaryl, arylamino, aralkylamino, alkylsulfonyl, -carboxamidoalkylaryl, -carboxamidoaryl, hydroxyalkyl, haloalkyl, alkylaminoalkylcarboxy-, aminocarboxamidoalkyl-, cyano, alkoxyalkyl, perhaloalkyl, arylalkyloxyalkyl, (e.g., SO₄(R')₂), a phosphate (e.g., PO₄(R')₃), a silane (e.g., Si(R')₄), a urethane (e.g., R'O(CO)NHR'), and the like. Additionally, the substituents may be selected from F, Cl, Br, I, —OH, —NO₂, —CN, —NCO, —CF₃, —CH₂CF₃, —CHCl₂, —CH₂OR_x, —CH₂CH₂OR_x, —CH₂N(R_x)₂, —CH₂SO₂CH₃, —C(O)R_x, —CO₂(R_x), —CON(R_x)₂, —OC(O)R_x, —C(O)OC(O)R_x, —OCO₂R_x, —OCON(R_x)₂, —N(R_x)₂, —S(O)₂R_x, —OCO₂R_x, —NR_x(CO)R_x, —NR_x(CO)N(R_x)₂, wherein each occurrence of R_x independently includes, but is not limited to, H, aliphatic, alicyclic, heteroaliphatic, heteroalicyclic, aryl, heteroaryl, alkylaryl, or alkylheteroaryl, wherein any of the aliphatic, alicyclic, heteroaliphatic, heteroalicyclic, alkylaryl, or alkylheteroaryl substituents described above and herein may be substituted or unsubstituted, branched or unbranched, cyclic or acyclic, and wherein any of the aryl or heteroaryl substituents described above and herein may be substituted or unsubstituted.

[0207] The following references are herein incorporated by reference: U.S. Provisional Patent Application Ser. No. 61/103,898, filed Oct. 8, 2008, entitled “Catalyst Compositions and Photoanodes for Photosynthesis Replication and Other Photoelectrochemical Techniques,” by Nocera, et al., U.S. Provisional Patent Application Ser. No. 61/218,006, filed Jun. 17, 2009, entitled “Catalytic Materials, Photoanodes, and Systems for Water Electrolysis and Other Electrochemical Techniques,” by Nocera, et al., U.S. Provisional Patent Application Ser. No. 61/103,905, filed Oct. 8, 2008, entitled “Catalyst Compositions and Photoanodes for Photosynthesis Replication and Other Photoelectrochemical Techniques,” by Nocera, et al., U.S. Provisional Patent Application

Ser. No. 61/187,995, filed Jun. 17, 2009, entitled "Catalytic Materials, Photoanodes, and Systems for Water Electrolysis and Other Electrochemical Techniques," by Nocera, et al., U.S. Provisional Patent Application Ser. No. 61/073,701, filed Jun. 18, 2008, entitled "Catalyst Compositions and Electrodes for Photosynthesis Replication and Other Electrochemical Techniques," by Nocera, et al., U.S. Provisional Patent Application Ser. No. 61/084,948, filed Jul. 30, 2008, entitled "Catalyst Compositions and Electrodes for Photosynthesis Replication and Other Electrochemical Techniques," by Nocera, et al., U.S. Provisional Patent Application Ser. No. 61/103,879, filed Oct. 8, 2008, entitled "Catalyst Compositions and Electrodes for Photosynthesis Replication and Other Electrochemical Techniques," by Nocera, et al., U.S. Provisional Patent Application Ser. No. 61/146,484, filed Jan. 22, 2009, entitled "Catalyst Compositions and Electrodes for Photosynthesis Replication and Other Electrochemical Techniques," by Nocera, et al., U.S. Provisional Patent Application Ser. No. 61/179,581, filed May 19, 2009, entitled "Catalyst Compositions and Electrodes for Photosynthesis Replication and Other Electrochemical Techniques," by Nocera, et al., and U.S. patent application Ser. No. 12/486,694, filed Jun. 17, 2009, entitled "Catalytic Materials, Electrodes, and Systems for Water Electrolysis and Other Electrochemical Techniques."

[0208] The following examples are intended to illustrate certain embodiments of the present invention, but are not to be construed as limiting and do not exemplify the full scope of the invention.

Example 1

[0209] The following example describes non-limiting examples of methods for deposition of a catalytic material comprising cobalt (Co-OEC) onto a photoactive material (e.g., a semiconductor, CdS). The method comprises, in this embodiment, providing a solution comprising metal ionic species and anionic species, providing a photoactive electrode, and causing the metal ionic species and the anionic species to form a catalytic material associated with the photoactive electrode by application of a voltage (e.g., by an external power source or by exposure to a light source) to the photoactive electrode.

[0210] Materials. Cadmium sulfate, thiourea, ammonium acetate, ammonium hydroxide solution (28% NH₃), cobalt nitrate, methylphosphonic acid (Aldrich) and fluorine-doped tin oxide (FTO) coated glass substrate (Solaronix) were used as received.

[0211] CdS Film Preparation. Thin films of CdS were prepared on FTO-coated glass substrates by the chemical bath deposition technique. An Erlenmeyer flask containing 100 mL of deionized, distilled water (ddH₂O) was placed in water bath and heated to 88° C. Two 2.5×5 cm FTO-coated glass substrates were placed in the bottom of the flask with the FTO face up. Cadmium sulfate (0.5 mM), ammonium acetate (10 mM), and ammonium hydroxide (0.4 M) were then added to the flask. After 10 minutes, four aliquots of thiourea were added to the flask to a final concentration of 0.975 mM with 10 minutes between aliquot additions. Ten minutes after the addition of the final thiourea aliquot, the substrates were removed from the bath and rinsed with ddH₂O. The entire procedure was repeated four times to yield substantially thick CdS films.

[0212] Electrodeposition of Co-OEC on CdS films. The CdS film prepared on FTO-coated glass substrate (e.g., a photoactive electrode) was connected to a potentiostat (CH Instruments 760C) via an alligator clip and immersed in water containing 2 mM cobalt nitrate and 0.1 M methylphosphonic

acid (pH 8.5) (e.g., a solution comprising metal ionic species and anionic species). An Ag/AgCl reference electrode (BASi) and platinum wire counter electrode were connected to the potentiostat and immersed in the solution. The CdS electrode was biased at 1.5 V vs. Ag/AgCl for one hour (application of a voltage to the photoactive electrode using an external power source). The CdS electrode was then removed from solution and rinsed with deionized water. FIG. 14 shows a scanning electron micrograph (SEM) of the resulting electrode. The dark material on top is the resulting Co-OEC catalytic material (e.g., catalytic material associated with the photoactive electrode comprising metal ionic species and anionic species) that has been electrodeposited onto the CdS semiconductor underneath. As shown in FIG. 14, a large portion of the Co-OEC overlayer has flaked away during drying of the electrode for SEM, revealing the CdS film underneath. Electron dispersive x-ray (EDX) analysis confirms the presence of Co, Cd, S, and P.

[0213] Photodeposition of Co-OEC on CdS. The CdS film prepared on FTO-coated glass substrate was connected to a potentiostat (CH Instruments 760C) via an alligator clip and immersed in water containing 2 mM cobalt nitrate and 0.1 M methylphosphonic acid (pH 8.5). An Ag/AgCl reference electrode (BASi) and platinum wire counter electrode were connected to the potentiostat and immersed in the solution. The electrode was held at 0.5 V vs. Ag/AgCl and illuminated for one hour with light (e.g., application of a voltage using an external light source) from a 300 W Xe arc lamp equipped with a 495 nm long pass filter ($\lambda > 495$ nm) and a 0.8 AU neutral density filter. The electrode was then removed from solution and rinsed with ddH₂O. FIG. 15 shows an SEM of the resulting electrode, both for regions that were exposed to light (FIG. 15A) and maintained in the dark (FIG. 15B). The illuminated portion of the film (FIG. 15A) exhibits a cracked morphology, which may be attribute to drying of the resulting Co-OEC overlayer coating. The region of film that was not exposed to light did not exhibit this cracking morphology and, instead, shows a uniform CdS film. EDX analysis confirms the presence of Co, Cd, S, and P for the film exposed to light, while films kept in the dark lacked measurable diffraction peaks for Co and P.

Example 2

[0214] The following prophetic example describes methods for formation of a Co-OEC functionalized photoanode and characterization of the enhanced photoassisted water oxidation reaction rate.

[0215] Nanostructured iron oxide semiconductor (α -Fe₂O₃) may be grown on electrically conductive FTO-coated glass substrates by the atmospheric chemical vapor deposition (CVD) technique as described previously (e.g., See Kay et al., *J. Am. Chem. Soc.*, 2006, 128, 15714-15721). The substrate may then be attached to a potentiostat as the working electrode and immersed in a solution of 0.1 M KPi (pH 7) and 0.5 mM Co(NO₃)₂. The electrode may then be biased at 1.1 V vs. Ag/AgCl reference for the electrodeposition of the Co-OEC catalyst as described in Example 1 and as done previously on ITO electrodes (e.g., see Kanan et al., *Science*, 2008, 321, 1072). The resulting α -Fe₂O₃/Co-OEC electrode may then serve as a photoanode.

[0216] The α -Fe₂O₃/Co-OEC photoanode may exhibit an enhanced rate for photoassisted water oxidation, compared to the α -Fe₂O₃ photoanode alone. Photoanodes may be immersed in 1 M NaOH aqueous electrolyte, along with an Ag/AgCl reference and Pt wire counter electrode. The photoanode may then be illuminated with AM 1.5 simulated solar irradiation and a bias applied and swept from -0.2 to 0.6 V vs.

Ag/AgCl reference. In this experiment, the photocurrent onset potential is the applied bias potential at which the photoanode exhibits a measurable anodic (oxidative) current and is familiar to those skilled in the art. The onset potential may be observed to shift to less positive values for the $\alpha\text{-Fe}_2\text{O}_3/\text{Co-OEC}$ photoanode compared to $\alpha\text{-Fe}_2\text{O}_3$ alone, owing to the catalytic effect of the Co-OEC water oxidation catalyst. Additionally, the overall magnitude of the anodic photocurrent may be larger for the $\alpha\text{-Fe}_2\text{O}_3/\text{Co-OEC}$ photoanode compared to $\alpha\text{-Fe}_2\text{O}_3$ alone. An incident photon-to-current efficiency (IPCE) measurement may then be carried out, in which the photon-to-current conversion efficiency is measured as a function of excitation wavelength. Devices and methods for measuring the IPCE will be known to those of ordinary skill in the art. The IPCE may be shown to increase by some value (e.g., at least about 50%, at least about 100%, at least about 200%, etc.) as a function of excitation wavelength for the $\alpha\text{-Fe}_2\text{O}_3/\text{Co-OEC}$ photoanode compared to $\alpha\text{-Fe}_2\text{O}_3$ alone.

Example 3

[0217] The following prophetic example describes non-limiting methods for water oxidation, O_2 gas evolution, and detection using Co-OEC functionalized photoanodes.

[0218] A Co-OEC functionalized photoanode (e.g., as prepared according to Example 1 or 2, or otherwise as described herein) may be attached to a potentiostat and serves as the working electrode for this experiment. The working electrode may be immersed in a buffered aqueous solution (e.g., 1 M KPi, pH 7) along with a reference electrode (e.g., Ag/AgCl) and an auxiliary electrode (e.g., Pt wire). The entire experiment may then be sealed from the environment (e.g., using rubber septa in ground glass joints attached to the electrochemical cell housing) and purged of air by bubbling with He gas (or other inert gas, e.g., N_2 , Ar). The photoanode may then be biased at some potential relative to the reference electrode (e.g., $0 < E < 1.5$ V). The photoanode may then be illuminated with light (e.g., from a Xe arc lamp that may or may not be filtered to produce solar AM 1.5 radiation) through a transparent (e.g., quartz) window in the reaction vessel. The light may or may not pass through the back side of the photoanode, such that the semiconductor is illuminated first prior to illumination of the Co-OEC film. Anodic photocurrents may be measured with the potentiostat. Bubbles may or may not be visible at the photoanode. Gaseous products of the photoelectrochemical reaction may then be analyzed by withdrawing samples of the reaction headspace using a gas-tight syringe and injecting the sample into a gas chromatograph/mass spectrometer. The detection of a peak with $m/z=32$ should indicate the production of O_2 . This may be confirmed by operation of the photoelectrochemical cell in water containing some fraction of H_2^{18}O and with the detection of peaks with $m/z=34$ ($^{18,16}\text{O}_2$) and $m/z=36$ ($^{18,18}\text{O}_2$). Gaseous oxygen may also be detected and quantified using a phosphorescence-based O_2 sensing probe (e.g., FOXY, Ocean Optics).

[0219] Control experiments may also be performed. The same semiconductor photoanode minus the Co-OEC catalytic material may be tested for photoelectrochemical water oxidation, the photocurrents measured, and the O_2 quantified with similar methods. The catalytic effect of Co-OEC should yield higher photocurrents and larger amounts of O_2 produced per unit time for the Co-OEC/semiconductor photoanode compared to the semiconductor alone.

Example 4

[0220] The following prophetic example describes non-limiting methods for fabricating a Co-OEC functionalized tandem photoelectrochemical cell (e.g., n-CdS/n-TiO₂).

[0221] A tandem photoelectrochemical cell composed of n-CdS/n-TiO₂ may be fabricated as previously described (e.g., See Nakato et al., *Nature*, 1982, 295, 312-313). The cell is composed of a sandwich of one n-TiO₂ wafer and one n-CdS wafer. The sandwich houses a solution of 1 M NaOH, 1 M Na₂S, and 1.5 gram atom 1^{-1} S, which is maintained by epoxy sealant on the edges of the wafers. The outer face of the CdS wafer is attached to a copper wire via an indium metal contact. The outer face of the TiO₂ wafer is exposed to solution as the surface for water oxidation.

[0222] The tandem PEC thus described may then be functionalized with Co-OEC using a photodeposition procedure, for example, as described in Example 1. In particular, the n-CdS/n-TiO₂ photoelectrode may be immersed in the anode compartment of a two-compartment photoelectrochemical cell containing an aqueous solution of 0.5 mM $\text{Co}(\text{NO}_3)_2$ and 0.1 M KPi (pH 7). The copper wire from the CdS wafer may be attached to a platinum gauze electrode immersed in the cathode compartment of the cell, which may contain 0.1 M KPi (pH 7). The anode and cathode compartments may be separated by a glass frit or a membrane. Excitation of the anode with light of wavelength less than or equal to 400 nm may then effect the deposition of the Co-OEC catalyst on the outer surface of the TiO₂ wafer. The photolysis time may correlate with the thickness of the Co-OEC film. The photocurrent may or may not be observed to rise with photolysis time.

[0223] The Co-OEC functionalized tandem PEC may then be tested for enhanced photoassisted water oxidation as described in Example 2 and for O_2 evolution, for example, as described in Example 3.

Example 5

[0224] The following prophetic examples described a non-limiting method for fabricating and testing a Co-OEC functionalized tandem photovoltaic-photoelectrochemical device (e.g., p,n-GaAs/p-GaInP₂).

[0225] A device may be fabricated in which a p-GaInP₂ photocathode is grown on top of a p,n-GaAs photovoltaic, as previously described (e.g., See Khaselev et al., *Science*, 1998, 280, 425-427). The device may be electrically connected to conductive anode support (e.g., Pt, FTO, Ni). The device may be immersed in electrolyte within a two-compartment cell. The anode compartment may contain the conductive anode support, 0.1 M KPi buffer (pH 7), and 0.5 mM $\text{Co}(\text{NO}_3)_2$. The cathode compartment may contain the p,n-GaAs/p-GaInP₂ device and 0.1 M KPi buffer (pH 7). The two compartments may be separated by a glass frit. Illumination of the p,n-GaAs/p-GaInP₂ device may produce a current and initiate deposition of the Co-OEC catalyst on the anode. The photocurrents may be observed to increase with Co-OEC layer thickness due to the catalytic effect of Co-OEC. The Co-OEC functionalized tandem photovoltaic-photoelectrochemical device may then be tested for O_2 evolution, for example, as described in Example 3 with the exception that in this case the cathode is illuminated with light, rather than the anode.

Example 6

[0226] The following prophetic example describes a non-limiting method for fabricating and testing of a Co-OEC functionalized dye-sensitized photoanode. In this embodiment, the method comprises providing a solution comprising metal ionic species and anionic species, providing a photoactive electrode comprising a photoactive composition and a photosensitizing agent, and causing the metal ionic species

and the anionic species to form a composition associated with the photoactive electrode by application of a voltage to the photoactive electrode.

[0227] Mesoporous titanium dioxide (TiO_2) films (e.g., photoactive composition) may be prepared on a conducting glass substrate (e.g., FTO glass) and RuL_3 ($L=2,2'$ -bipyridine-4,4'-dicarboxylic acid) dye (e.g., photosensitizing agent) may be adsorbed to the TiO_2 film as described previously (e.g., see O'Regan et al., *J. Phys. Chem.*, 1990, 94, 8720-8726). Thus formed, the dye-sensitized photoanode (e.g., photoactive electrode) may then be attached to the working electrode of a potentiostat and immersed in a two-compartment cell. The anode compartment may contain the dye-sensitized photoanode, an Ag/AgCl reference electrode, 0.5 mM $\text{Co}(\text{NO}_3)_2$, and 0.1 M KPi buffer (pH 7) (e.g., solution comprising metal ionic species and anionic species). The cathode compartment may contain hydrogen evolution electrode (e.g., a Pt-wire). The Co-OEC catalyst may then be electro- or photodeposited at the anode (e.g., composition associated with the photoactive electrode), for example, as described in Example 1 (e.g., by application of voltage to the photoactive electrode, via an external power source or via a light source). The device may then be tested for enhanced photoassisted water oxidation, (e.g., as described in Example 2) and photochemical O_2 evolution (e.g., as described in Example 3).

Example 7

[0228] The following prophetic example describes a non-limiting example of a photoanode comprising a band-gap engineered titanium dioxide semiconductor.

[0229] Titanium dioxide (TiO_2) has a band-gap of 3.0 eV, thus limiting its absorption to UV light (<2% of the solar spectrum). Significant research has focused on the engineering of this metal oxide semiconductor to lower its band-gap and allow for the absorption of visible light. For example, TiO_2 has been doped with nitrogen, carbon, and sulfur atoms, to raise the energy of the valence band (e.g., see Asahi et al., *Science*, 2001, 293, 269-271). In most embodiments, absorbed red photons do not contribute to substantial photocurrents, thus the overall efficiency of these materials for solar powered water oxidation remains low. The mechanism of water oxidation at TiO_2 surfaces may involve the formation of 1-electron oxidized, high energy intermediates (i.e. hydroxyl radicals, $\cdot\text{OH}$), thus owing to the inability of TiO_2 to support the 4-electron hole ($4h^+$) catalysis of water oxidation. Upon doping, the valence band electron-holes generally lack the oxidative power to produce $\cdot\text{OH}$ (FIG. 16), thus shutting down water oxidation chemistry. In contrast, the Co-OEC catalyst may be found to operate near the 4-electron/hole potential for water oxidation with low overpotential. FIG. 16 shows the band edge positions of various forms of TiO_2 along with the standard reduction potential of the hydroxyl radical and the potential for operation of the Co-OEC catalyst. Photogenerated electron-holes in band-gap engineered TiO_2 may thus possess sufficient energy to oxidize any Co-OEC adsorbed at the surface. Thus, deposition of a thin film of Co-OEC on band-gap engineered TiO_2 may engender photochemical water oxidation activity in this otherwise inactive material.

[0230] Thin films of nitrogen-doped TiO_2 may be prepared by sputtering, sol-gel, and solution anodization of Ti. Co-OEC films may then be formed by electro- and photodeposition methods, as described herein. Incident photon-to-current efficiency (IPCE) may be measured (e.g., as described herein) to test for enhanced photochemical response of the doped

TiO_2 upon adsorption of the Co. Undoped TiO_2 films, which show no IPCE response for visible wavelength excitation, may be used as a control.

Example 8

[0231] The following prophetic example describes the stabilization of soft photoactive semiconductors towards photocorrosion in aqueous media.

[0232] Electron-holes photogenerated in the valence band of soft n-type semiconductors may diffuse to the semiconductor-electrolyte interface where they initiate corrosion of the material. The formation of a hole-tunneling layer on the surface of the soft n-type semiconductor may prevent oxidation of the semiconductor lattice and photocorrosion. The Co-OEC catalyst may then be deposited on the hole-tunneling layer. Tunneling of the electron-hole out of the semiconductor valence band, through the hole-tunneling layer, and into surface-adsorbed Co-OEC may provide a mechanism for water oxidation that circumvents photoanode corrosion. The hole tunneling layer material may be another semiconductor material (e.g., TiO_2) and may be chosen such that the valence band of the hole tunneling layer is more positive in potential energy with respect to the valence band of underlying soft, photoactive semiconductor (e.g., CdS).

[0233] CdS films may be prepared by the chemical bath technique described in Example 1. TiO_2 films may then be prepared over the CdS film by standard sputtering, sol-gel, or electrodeposition techniques. Co-OEC catalyst films may then be photo- and/or electrodeposited from aqueous solutions of Co(II) ions as described in Example 1. The TiO_2 films may be prepared such that they are thin enough (e.g., ~10 nm thick) to allow for efficient tunneling of the electron hole from the underlying CdS layer into the Co-OEC film. Electrode photostability may be characterized as a function of light intensity, catalyst deposition conditions, thickness, and/or substrate morphologies. Materials that are photoactive toward oxygen evolution and produce stable photocurrents on long timescales may be further optimized.

Example 9

[0234] The following prophetic example describes non-limiting designs of photoelectrochemical cells.

[0235] A single band gap device (FIG. 17A) contains a single light-absorbing semiconductor material. The conduction band electrons and valence band holes produced upon excitation have suitable energy for proton reduction and water oxidation, respectively. The valence band holes are transported into the adsorbed CoPi catalyst, while the electrons may be directed to the cathode catalyst either coated onto a separate electrode (as shown), or deposited onto the back of the ohmic contact of the semiconductor. The first method allows for collection of electrons and generation of hydrogen at a remote site, while the second method affords hydrogen evolution over the surface area of the photoanode. A range of cathode catalysts may be employed, including thin monolayers of Pt (e.g., deposited from solutions of H_2PtCl_6) or Pt on C and alloys of Cu, Mo, and Ni. Materials may be selected based on overall device performance and cost.

[0236] If the conduction band electrons do not have sufficient energy for proton reduction, a bias voltage may be required to perform the water splitting reaction. In FIG. 17B, this voltage is supplied by a p:n-junction PV stacked in series with the photoanode semiconductor. In this tandem configuration, blue photons are absorbed by the photoanode and red

photons are transmitted to the PV. The current collected by the ohmic contact may then be channeled to the cathode electrode for hydrogen evolution.

[0237] FIG. 17C depicts another type of tandem PEC, in which the PV has been replaced by a p-type semiconductor photocathode. Electron-holes are directed to the semiconductor-electrolyte interface for n-type semiconductors, and, similarly, electrons are directed to the surface of p-type semiconductors where they may be collected by an adsorbed layer of cathode catalyst for hydrogen evolution. Photocathodes may be comprised of p-CdS, p-Si, and p-Fe₂O₃, among others.

[0238] In some cases, PEC modules may also be produced on dimensions similar to that for commercial PVs (~1 m²). In a non-limiting design, as shown in FIG. 17D, a PEC system is housed within glass or plexiglass domes 218 that focus the light onto a semiconducting material coated with CoPi (e.g., 212) below. Oxygen (white circles) may evolve from the semiconductor/CoPi 212, while hydrogen (black circles) may evolve from a stainless steel or conducting plastic cathode (e.g., 208) coated with a cathode catalyst. The gases may be collected at the top of the anode and cathode compartments, which can be separated by gas-impermeable, ion-conductive membranes (e.g., 210). The device may comprise one or more electrolytes (e.g., 214, 216, generally aqueous) in the anode and cathode compartments. This device may require that the cost per unit area of membrane is lower than for the semiconductor/CoPi photoanode.

[0239] Alternatively, the membrane may be incorporated into the PEC semiconductor. FIG. 17E shows a tandem PEC in which holes have been drilled and filled with the membrane material. Oxygen may be generated from the photoanode and released into the atmosphere, while hydrogen may be generated at the photocathode underneath and trapped at the apex of the device. The gases may also be produced by collecting the electrodes the photocathode and concentrating them at a separate electrode compartment as shown in FIG. 17F. An ion-permeable membrane may provide contact between the anode and cathode compartment while keeping the hydrogen and oxygen gases separate.

[0240] While several embodiments of the present invention have been described and illustrated herein, those of ordinary skill in the art will readily envision a variety of other means and/or structures for performing the functions and/or obtaining the results and/or one or more of the advantages described herein, and each of such variations and/or modifications is deemed to be within the scope of the present invention. More generally, those skilled in the art will readily appreciate that all parameters, dimensions, materials, and configurations described herein are meant to be exemplary and that the actual parameters, dimensions, materials, and/or configurations will depend upon the specific application or applications for which the teachings of the present invention is/are used.

[0241] Those skilled in the art will recognize, or be able to ascertain using no more than routine experimentation, many equivalents to the specific embodiments of the invention described herein. It is, therefore, to be understood that the foregoing embodiments are presented by way of example only and that, within the scope of the appended claims and equivalents thereto, the invention may be practiced otherwise than as specifically described and claimed. The present invention is directed to each individual feature, system, article, material, kit, and/or method described herein. In addition, any combination of two or more such features, systems, articles, materials, kits, and/or methods, if such features, systems,

articles, materials, kits, and/or methods are not mutually inconsistent, is included within the scope of the present invention.

[0242] The indefinite articles “a” and “an,” as used herein in the specification and in the claims, unless clearly indicated to the contrary, should be understood to mean “at least one.”

[0243] The phrase “and/or,” as used herein in the specification and in the claims, should be understood to mean “either or both” of the elements so conjoined, i.e., elements that are conjunctively present in some cases and disjunctively present in other cases. Other elements may optionally be present other than the elements specifically identified by the “and/or” clause, whether related or unrelated to those elements specifically identified unless clearly indicated to the contrary. Thus, as a non-limiting example, a reference to “A and/or B,” when used in conjunction with open-ended language such as “comprising” can refer, in one embodiment, to A without B (optionally including elements other than B); in another embodiment, to B without A (optionally including elements other than A); in yet another embodiment, to both A and B (optionally including other elements); etc.

[0244] As used herein in the specification and in the claims, “or” should be understood to have the same meaning as “and/or” as defined above. For example, when separating items in a list, “or” or “and/or” shall be interpreted as being inclusive, i.e., the inclusion of at least one, but also including more than one, of a number or list of elements, and, optionally, additional unlisted items. Only terms clearly indicated to the contrary, such as “only one of” or “exactly one of,” or, when used in the claims, “consisting of,” will refer to the inclusion of exactly one element of a number or list of elements. In general, the term “or” as used herein shall only be interpreted as indicating exclusive alternatives (i.e. “one or the other but not both”) when preceded by terms of exclusivity, such as “either,” “one of,” “only one of,” or “exactly one of.” “Consisting essentially of,” when used in the claims, shall have its ordinary meaning as used in the field of patent law.

[0245] As used herein in the specification and in the claims, the phrase “at least one,” in reference to a list of one or more elements, should be understood to mean at least one element selected from any one or more of the elements in the list of elements, but not necessarily including at least one of each and every element specifically listed within the list of elements and not excluding any combinations of elements in the list of elements. This definition also allows that elements may optionally be present other than the elements specifically identified within the list of elements to which the phrase “at least one” refers, whether related or unrelated to those elements specifically identified. Thus, as a non-limiting example, “at least one of A and B” (or, equivalently, “at least one of A or B,” or, equivalently “at least one of A and/or B”) can refer, in one embodiment, to at least one, optionally including more than one, A, with no B present (and optionally including elements other than B); in another embodiment, to at least one, optionally including more than one, B, with no A present (and optionally including elements other than A); in yet another embodiment, to at least one, optionally including more than one, A, and at least one, optionally including more than one, B (and optionally including other elements); etc.

[0246] In the claims, as well as in the specification above, all transitional phrases such as “comprising,” “including,” “carrying,” “having,” “containing,” “involving,” “holding,” and the like are to be understood to be open-ended, i.e., to mean including but not limited to. Only the transitional phrases “consisting of” and “consisting essentially of” shall be closed or semi-closed transitional phrases, respectively, as

set forth in the United States Patent Office Manual of Patent Examining Procedures, Section 2111.03.

What is claimed:

1. A method for forming a photoanode for the catalytic production of oxygen from water, comprising:
 - providing a solution comprising metal ionic species and anionic species;
 - providing a photoactive electrode comprising a photoactive composition and a photosensitizing agent; and
 - causing the metal ionic species and the anionic species to form a catalytic material associated with the photoactive electrode by application of a voltage to the photoactive electrode.
2. A method for producing oxygen from water, comprising the steps of:
 - providing a photoelectrochemical cell comprising:
 - a photoactive electrode comprising a photoactive composition and a photosensitizing agent;
 - an electrolyte; and
 - a catalytic material integrally connected to the photosensitizing agent, the catalytic material comprising metal ionic species and anionic species, and wherein the catalytic material does not consist essentially of a metal oxide or metal hydroxide; and
 - illuminating the photoelectrochemical cell with light to thereby produce oxygen gas from water.
- 3-9. (canceled)
10. The method of claim 1, wherein the voltage is applied to the photoactive electrode by a power source.
11. (canceled)
12. The method of claim 1, wherein the voltage is applied to the photoactive electrode by exposing the photoactive electrode to electromagnetic radiation.
- 13-33. (canceled)
34. The method of claim 1, wherein the anionic species comprises phosphorus.
35. The method of claim 1, wherein the metal ionic species comprises cobalt ions.
36. (canceled)
37. The method of claim 1, wherein the metal ionic species with an oxidation state of (n+x) and the anionic species define a substantially non-crystalline composition and have a K_{sp} value which is less, by a factor of at least 10^3 , than the K_{sp}

value of a composition comprising the metal ionic species with an oxidation state of (n) and the anionic species.

38. (canceled)
39. The method of claim 2, wherein the photoelectrochemical cell further comprises a second electrode.
- 40-41. (canceled)
42. The method of claim 39, wherein the second electrode is a photoactive electrode.
- 43-49. (canceled)
50. The method of claim 2, wherein the water contains at least one impurity
- 51-89. (canceled)
90. The method of claim 1, wherein the photosensitizing agent comprises a metal complex dye.
91. The method of claim 1, wherein the photosensitizing agent comprises an organic dye.
- 92-107. (canceled)
108. A photoanode for the catalytic production of oxygen from water, comprising:
 - a photoactive electrode comprising a photosensitizing agent and a photoactive composition; and
 - a catalytic material comprising metal ionic species and anionic species, wherein the catalytic material is formed by application of a voltage to a photoactive electrode.
109. The photoanode of claim 108, wherein the metal ionic species comprises cobalt ions.
110. The photoanode of claim 108, wherein the anionic species comprises phosphorus.
- 111-162. (canceled)
163. The photoanode of claim 108, wherein the metal ionic species comprise at least a first and a second type of metal ionic species.
- 164-169. (canceled)
170. The photoanode of claim 108, wherein the photosensitizing agent comprises a metal complex dye.
171. The photoanode of claim 108, wherein the photosensitizing agent comprises an organic dye.
- 172-234. (canceled)
235. The method of claim 2, wherein the anionic species comprises phosphorus.
236. The method of claim 2, wherein the metal ionic species comprises cobalt ions.

* * * * *