



(19) **United States**

(12) **Patent Application Publication**  
**Hendershot et al.**

(10) **Pub. No.: US 2010/0077945 A1**

(43) **Pub. Date: Apr. 1, 2010**

(54) **CONVECTIVE SECTION COMBUSTION**

(21) Appl. No.: 12/238,671

(75) Inventors: **Reed Jacob Hendershot**,  
Breinigsville, PA (US); **Aleksandar**  
**Georgi Slavejkov**, Allentown, PA  
(US); **Mark Daniel D'Agostini**,  
Ebensburg, PA (US); **Kevin Boyle**  
**Fogash**, Wescosville, PA (US);  
**Jeffrey William Kloosterman**,  
Allentown, PA (US)

(22) Filed: **Sep. 26, 2008**

**Publication Classification**

(51) **Int. Cl.**  
**F23B 80/00** (2006.01)  
**F23B 10/00** (2006.01)  
**F23J 15/00** (2006.01)  
(52) **U.S. Cl.** ..... **110/345**; 110/214; 110/263

Correspondence Address:  
**AIR PRODUCTS AND CHEMICALS, INC.**  
**PATENT DEPARTMENT**  
**7201 HAMILTON BOULEVARD**  
**ALLENTOWN, PA 181951501**

(57) **ABSTRACT**

An oxy/coal combustion system and method include a furnace arranged and disposed to receive and combust a first solid fuel to form a combustion fluid, a convective section having one or more inlet devices, the convective section arranged and disposed to receive and combust a second fuel in the presence of the oxygen, and one or more heat exchangers arranged and disposed to exchange heat with the combustion fluid.

(73) Assignee: **AIR PRODUCTS AND**  
**CHEMICALS, INC.**, Allentown,  
PA (US)

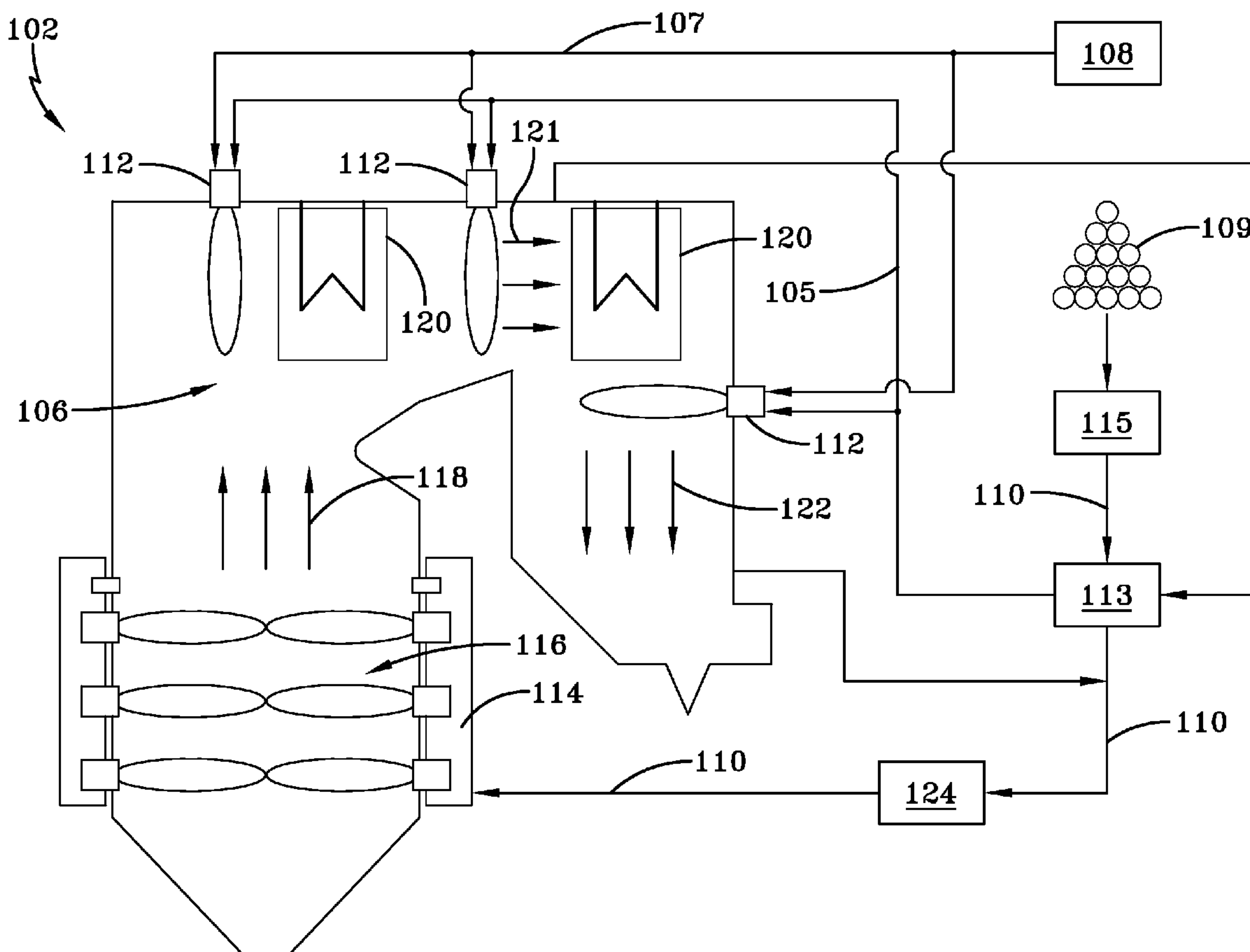

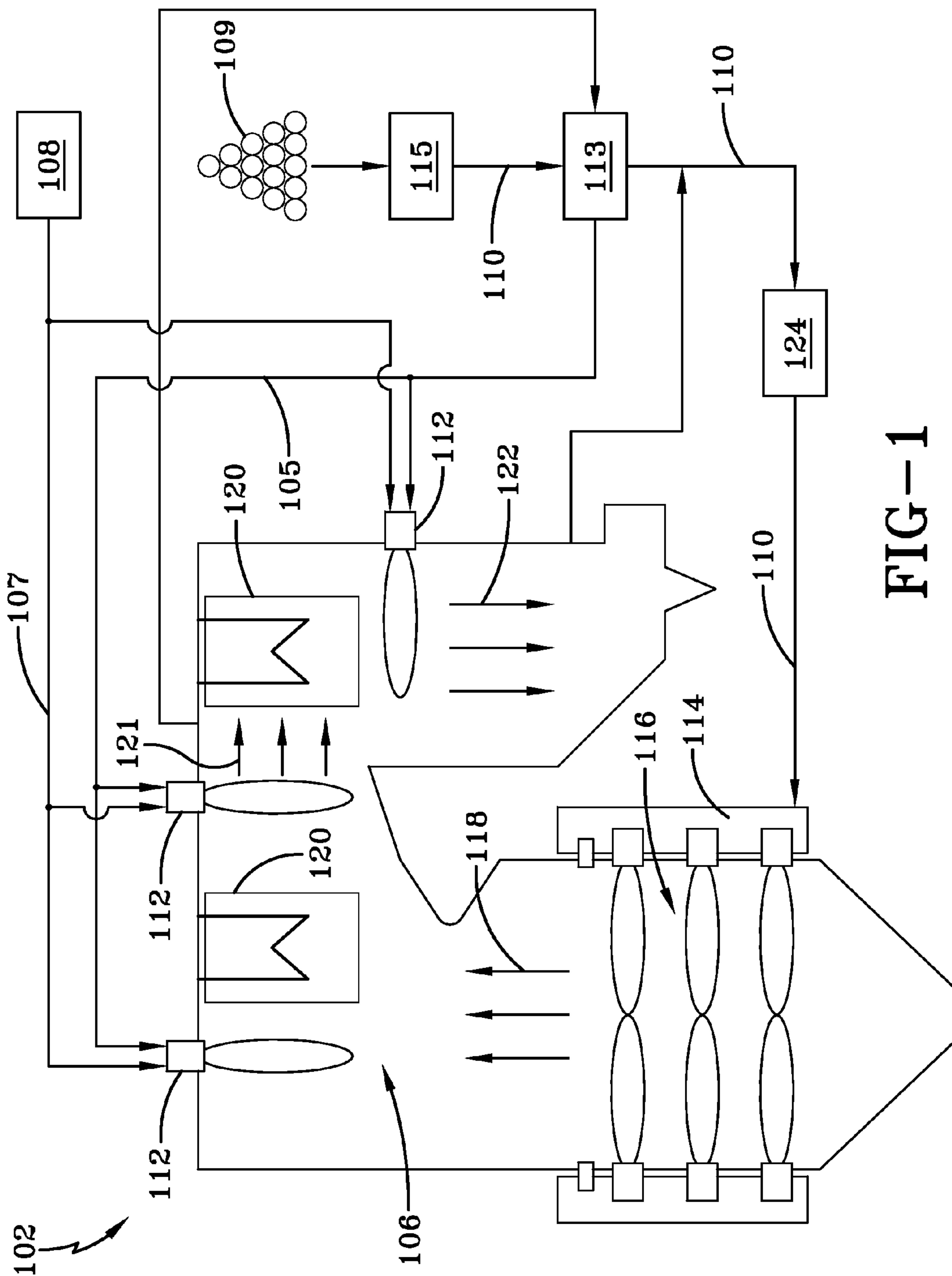

FIG-1

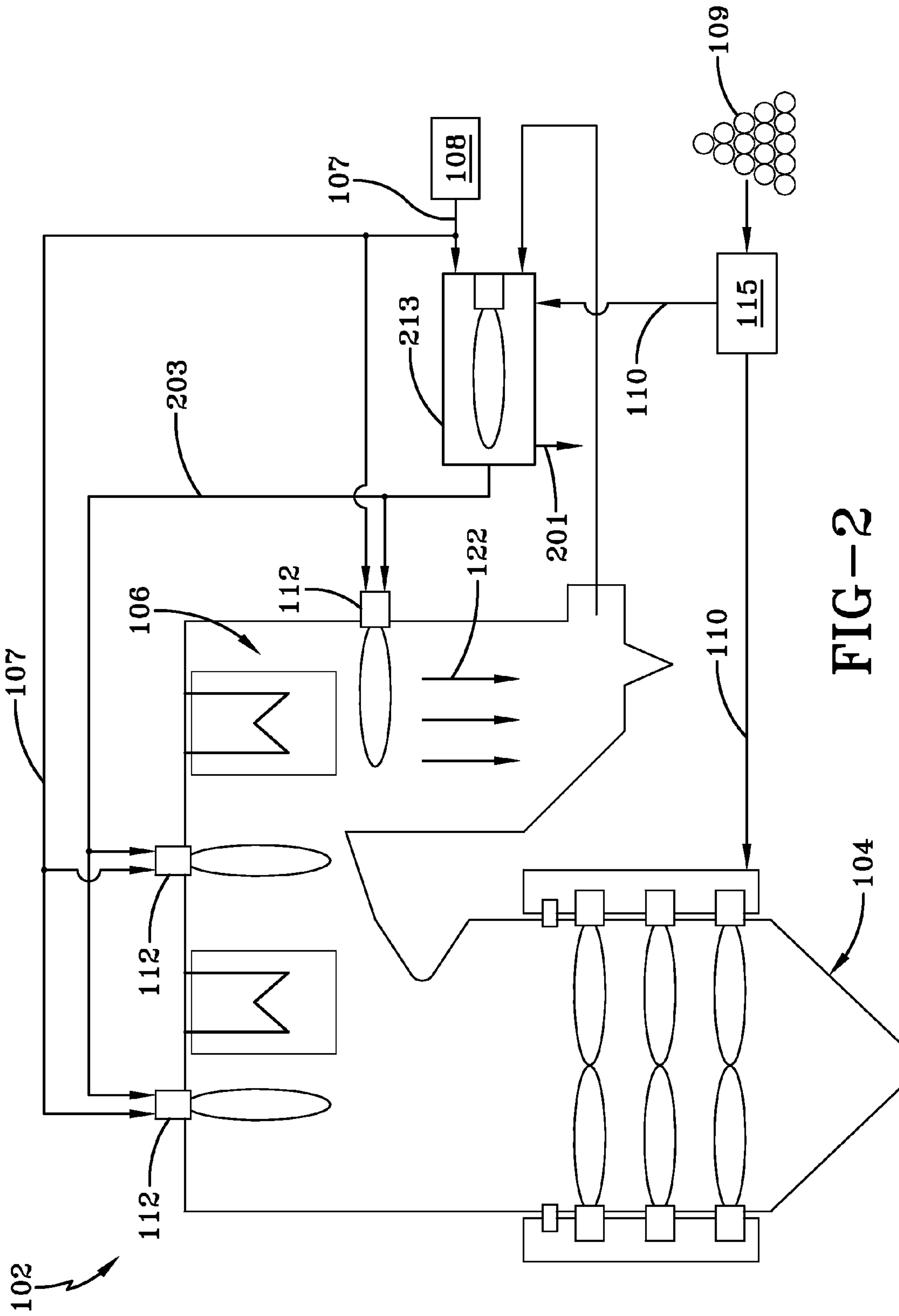

FIG-2

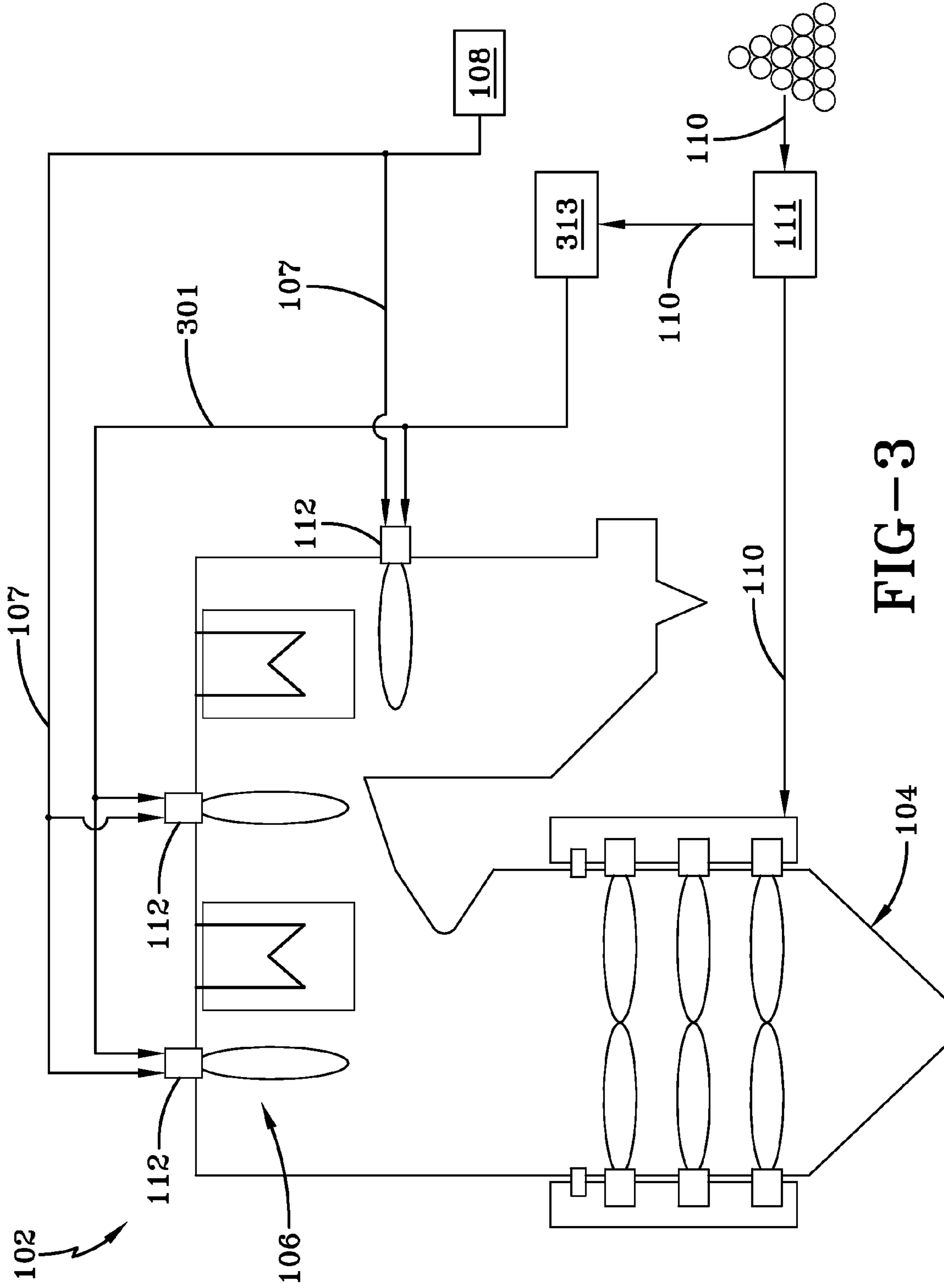

FIG-3

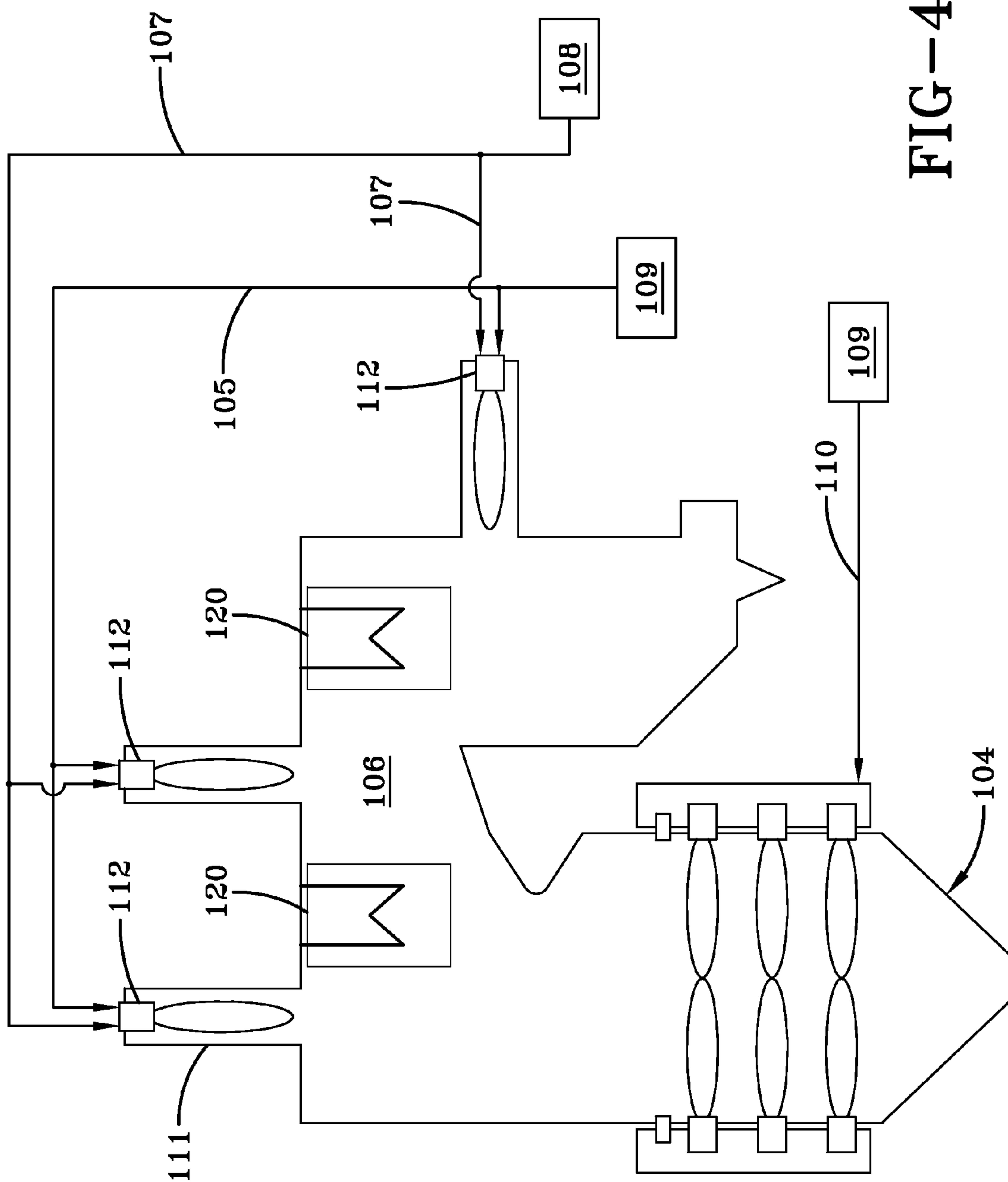

FIG-4

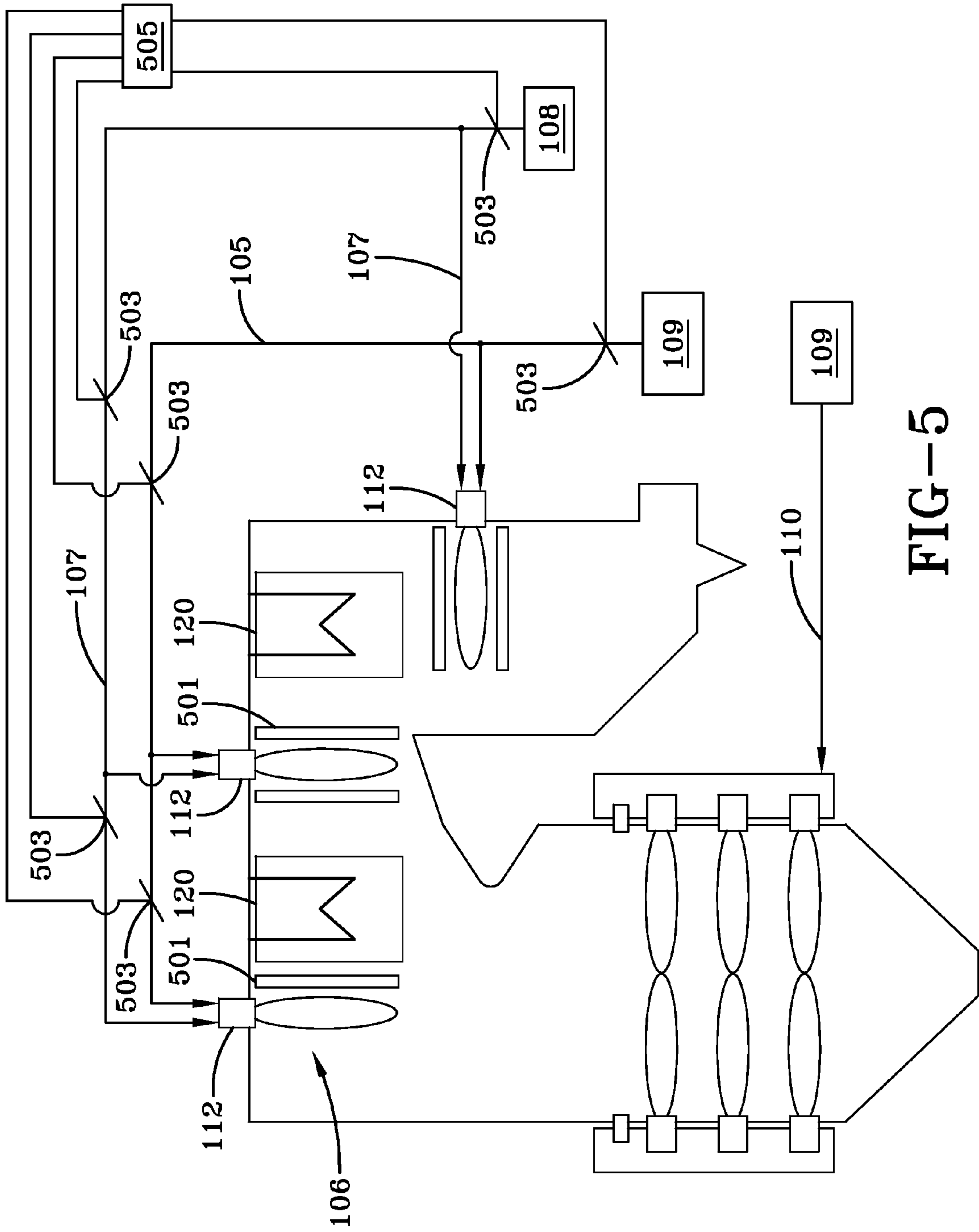

FIG-5



## CONVECTIVE SECTION COMBUSTION

### CROSS-REFERENCE TO RELATED APPLICATIONS

[0001] This Application is related to application Ser. No. \_\_\_\_\_, entitled "OXY/FUEL COMBUSTION SYSTEM WITH LITTLE OR NO EXCESS OXYGEN", Attorney Docket No. 07228 USA, filed contemporaneously with this Application on Sep. 26, 2008, assigned to the assignee of the present disclosure and which is herein incorporated by reference in its entirety, application Ser. No. \_\_\_\_\_, entitled "COMBUSTION SYSTEM WITH STEAM OR WATER INJECTION", Attorney Docket No. 07238 USA, filed contemporaneously with this Application on Sep. 26, 2008, assigned to the assignee of the present disclosure and which is herein incorporated by reference in its entirety, application Ser. No. \_\_\_\_\_, entitled "COMBUSTION SYSTEM WITH PRECOMBUSTOR", Attorney Docket No. 07255 USA, filed contemporaneously with this Application on Sep. 26, 2008, assigned to the assignee of the present disclosure and which is herein incorporated by reference in its entirety, application Ser. No. \_\_\_\_\_, entitled "OXY/FUEL COMBUSTION SYSTEM WITH MINIMIZED FLUE GAS RECIRCULATION", Attorney Docket No. 07257 USA, filed contemporaneously with this Application on Sep. 26, 2008, assigned to the assignee of the present disclosure and which is herein incorporated by reference in its entirety, application Ser. No. \_\_\_\_\_, entitled "OXY/FUEL COMBUSTION SYSTEM HAVING COMBINED CONVECTIVE SECTION AND RADIANT SECTION", Attorney Docket No. 07247 USA, filed contemporaneously with this Application on Sep. 26, 2008, assigned to the assignee of the present disclosure and which is herein incorporated by reference in its entirety, application Ser. No. \_\_\_\_\_, entitled "PROCESS TEMPERATURE CONTROL IN OXY/FUEL COMBUSTION SYSTEM", Attorney Docket No. 07239 USA, filed contemporaneously with this Application on Sep. 26, 2008, assigned to the assignee of the present disclosure and which is herein incorporated by reference in its entirety, and application Ser. No. \_\_\_\_\_, entitled "COMBUSTION SYSTEM WITH PRECOMBUSTOR", Attorney Docket No. 07262Z USA, filed contemporaneously with this Application on Sep. 26, 2008, assigned to the assignee of the present disclosure and which is herein incorporated by reference in its entirety.

### FIELD OF THE DISCLOSURE

[0002] The present disclosure is directed to a combustion system. In particular, the present disclosure is directed to a combustion system configured for solid fuel combustion in the convective section of the combustion system.

### BACKGROUND OF THE DISCLOSURE

[0003] In known systems, gas and/or oil have been used for reburning combustion fluid downstream of furnaces to control  $\text{NO}_x$  emissions. Gas and/or oil have an unreliable supply (especially in winter) costs can vary widely; they may have problems with firing dual fuels; and they may reduce efficiency of a system due to hydrogen content thereby increasing water vapor of combustion fluids. This reburning of combustion fluid has been used for decreasing  $\text{NO}_x$  emissions produced by reaction of nitrogen in combustion air (thermal  $\text{NO}_x$ ) and oxidation of nitrogen chemically bound in coal (fuel  $\text{NO}_x$ ).

[0004] In the reduction of  $\text{NO}_x$  emissions, known systems have provided finely divided, micronized particles of coal for reburning. Known systems include a furnace (or a radiant section) and a convective section. These systems focus on reducing  $\text{NO}_x$  emissions emanating from the system and have not, therefore, adequately provided for efficient transfer of heat (at least in part) in the convective section of the systems.

[0005] Oxy/fuel systems generate high combustion temperatures requiring heat release to be distributed to ensure high superheat temperatures and high efficiency. Known systems use recycled flue gas (RFG) to transfer heat from the furnace to the convective section. Using RFG to distribute heat increases the complexity of the flue gas handling system, the size of the convective section, and/or the size of the boiler. Thus, it increases the overall capital and operating costs of the systems. Since oxy/fuel system have a lower mass flux than air/fuel system (due to the removal of  $\text{N}_2$ ) and, therefore, a higher heat release and temperature, it is desirable to remove a larger percentage of the available heat generated in the furnace of the oxy/fuel system to the convective section thereby resulting in a controlled temperature in the convective section while controlling the temperature and heat release in the furnace.

[0006] Therefore, there is an unmet need to provide a method, system, and apparatus for reburning fuels other than oil and/or gas, for the purpose of controlling heat release and temperature within the system, and/or withstanding the increased heat in the convective section while minimizing the use of FGR.

### SUMMARY OF THE DISCLOSURE

[0007] According to an embodiment, an oxy/fuel combustion system includes a furnace arranged and disposed to receive and combust a first fuel to form a combustion fluid, the first fuel provided from a first solid fuel source, a convective section having an inlet device, the convective section arranged to receive the combustion fluid from the furnace and disposed to receive a second fluid, the second fluid converted from a second fuel, the second fuel being a solid fuel, and one or more heat exchangers in the convective section arranged and disposed to transfer heat from the combustion fluid to a heat exchange medium.

[0008] According to another embodiment, an oxy/fuel combustion method includes providing a furnace and a convective section, the furnace in fluid communication with the convective section, providing a first fuel from a first solid fuel source, receiving the first fuel in the furnace, combusting the first fuel in the furnace thereby producing a combustion fluid, receiving the combustion fluid in the convective section, converting a second fuel into a second fluid, the second fuel being a solid fuel, receiving the second fluid in a convective section, and transferring heat from the combustion fluid to a heat exchange medium.

[0009] The present disclosure allows for harnessing of energy in the convective section of a combustion system, thereby enabling transfer of heat to a heat exchange fluid, and increasing the heat content of the fluid.

[0010] Another advantage of the present disclosure is that fuel is burned not only in the furnace section, but also in the convective section of a combustion system.

[0011] Yet another advantage of the present disclosure is use of synthetic air ( $\text{CO}_2$  mixed with  $\text{O}_2$ ) and/or substantially pure  $\text{O}_2$  in a combustion system to combust fuel, while minimizing the use of RFG.



[0012] Still yet another advantage of the present disclosure is the ability to use a single source of fuel in the furnace as a primary fuel and the convective section as a secondary fuel.

[0013] Still yet another advantage of the present disclosure is increased heat transfer surface temperature control in the convective section.

[0014] Still yet another advantage of the present disclosure is increased control of the heat transfer fluid temperatures in the convective section (e.g. the superheat steam temperature).

[0015] Further aspects of the method and system are disclosed herein. The features as discussed above, as well as other features and advantages of the present disclosure will be appreciated and understood by those skilled in the art from the following detailed description and drawings.

#### BRIEF DESCRIPTION OF THE DRAWINGS

[0016] FIG. 1 illustrates a schematic view of an exemplary embodiment of a combustion system according to the disclosure.

[0017] FIG. 2 illustrates a schematic view of another exemplary embodiment of a combustion system according to the disclosure.

[0018] FIG. 3 illustrates a schematic view of yet another exemplary embodiment of a combustion system according to the disclosure.

[0019] FIG. 4 illustrates a schematic view still yet another exemplary embodiment of a combustion system according to the disclosure.

[0020] FIG. 5 illustrates a schematic view of a further exemplary embodiment of a combustion system according to the disclosure.

[0021] Wherever possible, the same reference numbers will be used throughout the drawings to represent the same parts.

#### DETAILED DESCRIPTION OF THE DISCLOSURE

[0022] The present disclosure now will be described more fully hereinafter with reference to the accompanying drawings, in which a preferred embodiment of the disclosure is shown. This disclosure may, however, be embodied in many different forms and should not be construed as limited to the embodiments set forth herein; rather, these embodiments are provided so that this disclosure will be thorough and complete and will fully convey the scope of the disclosure to those skilled in the art.

[0023] The present disclosure relates to enhanced generation of heat and balanced distribution of heat generation within a combustion system 102 by combusting fuel in both a furnace 104 and a convective section 106. The combustion is specifically applied to solid fuel combusted to produce a combustion fluid 118.

[0024] As used herein, the term “solid fuel” and grammatical variations thereof refers to any solid fuel suitable for combustion purposes. For example, the disclosure may be used with many types of carbon-containing solid fuels, including but not limited to: anthracite, bituminous, sub-bituminous, and lignitic coals; tar; bitumen; petroleum coke; paper mill sludge solids and sewage sludge solids; wood; peat; grass; and combinations and mixtures of all of those fuels. As used herein, the term “oxygen” and grammatical variations thereof refers to an oxidizer having an O<sub>2</sub> concentration greater than that of atmospheric or ambient conditions. As used herein, the term “oxy/coal combustion” and gram-

matical variations thereof refers to coal combustion in oxygen, the term “air/coal combustion” and grammatical variations thereof refers to coal combustion in air, the term “oxy/fuel combustion” and grammatical variations thereof refers to fuel combustion in oxygen, and the term “air/fuel combustion” and grammatical variations thereof refers to fuel combustion in air. As used herein, the term “combustion fluid” and grammatical variations thereof refers to a fluid formed from and/or mixed with the products of combustion, which may be utilized for convective heat transfer. The term is not limited to the products of combustion and may include fluids mixed with or otherwise traveling through at least a portion of combustion system. Although not so limited, one such example is flue gas. As used herein, the term “recycled flue gas” and grammatical variations thereof refers to combustion fluid exiting the system that is recirculated to any portion of the system. As used herein, the term “flue gas recycle” and grammatical variations thereof refers to a configuration permitting the combustion fluid to be recirculated. Although various embodiments illustrate flames in particular locations, it will be appreciated that flames may be present, but not necessarily required to be present, in any place where combustion occurs.

[0025] FIG. 1 illustrates an exemplary embodiment of the present disclosure. In FIG. 1, combustion system 102 includes furnace 104 arranged and disposed to receive a first fuel 110 to form a combustion fluid 118, a convective section 106 downstream of furnace section 104 arranged and disposed to receive combustion fluid 118 from furnace 104 and arranged and disposed to receive a second fluid 105, and one or more heat exchangers 120 arranged and disposed to transfer heat from combustion fluid 121 to a heat exchange medium (not shown).

[0026] As illustrated in FIG. 1, some embodiments further include a solid fuel conversion mechanism configured to convert solid fuel to a form that can be combusted in convective section 106. In other embodiments, solid fuel conversion mechanism is configured to combust (or partially combust) the solid fuel producing second fluid 105 which is transported to convective section 106. As used in the present disclosure, the term solid fuel conversion mechanism refers to systems for chemically or physically affecting a fuel. For example, the oxidation or reduction of a fuel would be a chemical conversion and the gasifying of a fuel would be physical conversion. These conversions may be performed in the solid fuel conversion mechanism.

[0027] As illustrated, furnace 104 is in fluid communication with convective section 106. In this embodiment, furnace 104 is arranged and disposed to receive first fuel 110 at a windbox 114 proximal to a general combustion zone 116. Furnace 104 is configured to combust first fuel 110 thereby producing combustion fluid 118 that is fed to convective section 106 of combustion system 102. As will be appreciated, among other components, windbox 114 and the general combustion zone 116 are merely exemplary and may be reconfigured or replaced with other furnace components or other mixing mechanisms.

[0028] FIG. 1 depicts convective section 106 as a part of combustion system 102. However, more than one furnace 104 and/or convective section 106 of the same combustion system or a separate combustion system may be used. In addition, furnace 104 and/or convective section 106 may be in fluid communication with other types of systems. Convective sections may be included in combustion fluid path 118, 121, and/or 122 as needed to improve the efficiency of combustion



system **102**. However, in other embodiments, convective section **106** may be a convective section to another combustion system, a portion between furnace **104** and convective section **106**, or a portion after the convective section. As illustrated in FIG. 1, three inlet devices **112** in convective section **106** are arranged and disposed to receive oxygen **107** from oxygen source **108**. In one embodiment, inlet devices **112** are arranged and disposed for combustion by including burners. Oxygen **107** may be mixed (for instance in a mixing chamber preceding inlet devices **112**, in the solid fuel conversion mechanism, or in convective section **106**) with second fluid **105** provided to convective section **106** in inlet devices **112**. As will be appreciated, air or other fluids may be used as a carrier fluid to transport second fluid **105** to the point where the second fluid **105** may be mixed with oxygen **107**. Only one inlet device **112** in convective section **106** is required, but additional inlet devices **112** and/or additional heat exchangers **120** are contemplated.

[0029] As illustrated in FIG. 1, convective section **106** includes a plurality of heat exchangers **120**. As will be appreciated, convective section **106** may include fewer or more heat exchangers **120**. Heat exchangers **120** may include any number of primary superheaters, any number of secondary superheaters, any number of reheaters, any number of economizers, or combinations thereof. As depicted in FIG. 1, one heat exchanger **120** is a secondary superheater (upstream from a primary superheater) and another heat exchanger **120** is the primary superheater (downstream from the secondary superheater). Additional heat exchangers **120** (not shown in FIG. 1) may be included. Other heat exchangers **120** may be economizers, reheaters, or additional superheaters.

[0030] Referring to FIG. 1, the solid fuel conversion mechanism is a fluidized bed **113**. In other embodiments (as described below), the solid fuel conversion mechanism may be an external reaction chamber **213** (see FIG. 2), a micronizing pulverizer **313** (see FIG. 3), a combustor, a burner, other similar devices, or combinations thereof. As illustrated in FIG. 1, first fuel **110** from solid fuel source **109** is fed to fluidized bed **113** after being crushed in a primary crusher **115**. In the embodiments illustrated by FIGS. 1, 2, and 3, first fuel **110** and/or other fluids being transported may be transported by any method as would be appreciated by those skilled in the art. For example, solid fuel may be transported by a carrier gas, mechanical systems, and/or pneumatic systems. Upon exiting primary crusher **115**, first fuel **110** (having been crushed) preferably is of an ambient temperature or about 80° F. (about 27° C). In the embodiment illustrated by FIG. 1, fluidized bed **113** performs at least partial devolatilization of first fuel **110** (having been crushed) thereby forming second fluid **105**, which is volatilized. As illustrated in FIG. 1, the at least partial devolatilization of first fuel **110** relies upon a hot combustion fluid **121** fed from downstream of a first heat exchanger **120** and two inlet devices **112** and upstream from a second heat exchangers **120** and another inlet device **112**. As will be appreciated, other sources of hot fluids (not necessarily hot combustion fluids) and inlet devices located in other areas may be included.

[0031] Referring again to FIG. 1, hot combustion fluid **121** is used to produce fluid **105**, a relatively low heating value gaseous fuel. In this embodiment, hot combustion fluid **121** may be about 1675° F. (about 913° C.) prior to being mixed with first fuel **110** at ambient conditions in a 1:1 mass ratio in fluidized bed **113** to achieve a final temperature of about 1000° F. (about 538° C.). Upon first fuel **110** being converted

by fluidized bed **113**, first fuel **110** (in part) is volatilized to form second fluid **105** and fed to inlet devices **112**. The remaining portion of first fuel **110** includes partially devolatilized solid fuel, which is fed to furnace **104**. In other embodiments, second fluid **105** is produced by converting a second fuel that is not the same fuel as first fuel **110**. The second fuel is provided by a second fuel source.

[0032] As illustrated in FIG. 1, in an embodiment, partially devolatilized first fuel **110** may be fed to a pulverizer **124** prior to being fed to furnace **104**. However, in other embodiments, pulverizer **124** may be omitted. In the embodiment illustrated by FIG. 1, partially devolatilized first fuel **110** exiting fluidized bed **113** is cooled by combustion fluid **122** fed from the end of combustion system **102**. Combustion fluid **122** may have a lower temperature and may also be used as a transport fluid to transport the partially devolatilized first fuel **110** to furnace **104**. As will be appreciated, combustion fluid **122** may also be exhausted from combustion system **102** and/or collected.

[0033] FIG. 2 illustrates another exemplary embodiment of the present disclosure. Combustion system **102** as disclosed in FIG. 2 is similar to combustion system **102** as disclosed in FIG. 1 primarily except that it includes external reaction chamber **213** as the solid fuel conversion mechanism. External reaction chamber **213** may be for partial fuel oxidation (for example, with a gasifier) or for complete fuel oxidation. In one embodiment, the solid fuel conversion mechanism may be a slagging gasifier such as, for example, a slagging cyclone. The type of gasifier is selected to provide the ability to achieve relatively long solid particle residence times and withstand high gas temperatures, thus promoting efficient gasification and/or combustion of the first fuel **110** with minimal carbon residue.

[0034] As illustrated in FIG. 2, external reaction chamber **213** may convert coal from the solid to a gaseous fuel **203** through partial oxidation. Using external reaction chamber **213** may result in a higher heating value than using fluidized bed **113** and may not require combustion fluid **118** to transport gaseous fuel **203** to inlet devices **112**. As used herein, the term heating value refers to the heat that is released when a specific volume or mass is combusted. For example, natural gas has a heating value of about 1000 BTU/scf (standard cubic foot) while CO and H<sub>2</sub> are a little more than 300 BTU/scf. In general, a higher heating value fuel is easier to combust and provides more heat. The exception is H<sub>2</sub>, it has a low heating value but is fairly easy to combust. As illustrated in FIG. 2, the heat available in convective section **106** may not be limited based upon the volatility of first fuel **110** used.

[0035] In addition, the higher heating value of the gaseous fuel **203** may result in more stable combustion in the convective section **106**. In one embodiment, the gasifier is included and provides sources of energy in the form of chemical sources (i.e. partially combusted fuel such as CO and others) and thermal sources (above ambient temperatures). In some cases, it may be valuable to extract heat from the reacted stream before injection into convective section **106**. The heat extraction from reaction chamber **213** or transfer piping may be integrated into the overall steam cycle. In this embodiment, for higher efficiency, inlet devices **112** are burners with oxygen **107** injected to facilitate more efficient combustion. In the illustrated embodiment, combustion fluid **122** exiting the convective section **106** is fed to external reaction chamber **213** to temper the gas temperature **203** before transport. In the



illustrated embodiment, much like may be done in furnace 104, slag 201 may be separated in the reaction chamber and captured.

[0036] FIG. 3 illustrates another exemplary embodiment of the present disclosure. Combustion system 102 as disclosed in FIG. 3 is similar to combustion system 102 as disclosed in FIG. 1 primarily except that it includes micronizing pulverizer 313 as the solid fuel conversion mechanism. The depicted micronizing pulverizer 313 is fed first fuel 110 from primary crusher 111. In the embodiment illustrated in FIG. 3, primary crusher 111 is arranged and disposed to separate first fuel 110. Generally, first fuel 110 is separated based upon the size of the particles of first fuel 110. As will be appreciated, various techniques may be used to separate first fuel 110. In the embodiment illustrated by FIG. 3, first fuel 110 that is below a predetermined particle size is fed to micronizing pulverizer 313. The remaining first fuel 110 is fed to furnace 104. In other embodiments, first fuel 110 may be split in other ways understood by those skilled in the art. In the embodiment illustrated by FIG. 3, micronizing pulverizer 313 is arranged and disposed to further pulverize first fuel 110 so that about 80% to 100% of first fuel 110 exiting the micronizing pulverizer 313 (the micronized solid fuel or second fluid 301) is at a size of less than about 45 micrometers. Specifically, the embodiment illustrated in FIG. 3 results in between 80% and 100% of second fluid 301 being less than 44 micrometers. Second fluid 301 may burn relatively easily and may be used in convective section 106. As illustrated in FIG. 3, second fluid 301 is fed to inlet devices 112 and combusted.

[0037] FIG. 4 illustrates an exemplary embodiment of the present disclosure. As illustrated in FIG. 4, inlet devices 112 are in convective section 106; however, convective section 106 includes recesses 111 that contain inlet devices 112. As illustrated in FIG. 4, inlet devices 112 are positioned within chambers forming recesses 111, aligning the edge of convective section 106. As illustrated in FIG. 4, second fluid 105 (but could be second fluid 203 or second fluid 301) is introduced at a point in convection section 106 proximal to inlet device 112. At this point, second fluid 105 and oxygen 107 are injected into the chamber to achieve stable combustion. In other embodiments, oxygen 107 may be part of second fluid 105 and not provided independently to the chamber. In yet other embodiments, to minimize peak flame temperatures from inlet devices 112, oxygen 107 and second fluid 105 staging may be used. Staging refers to mixing the fuel or oxidizer at several locations instead of all at once. This has the effect of lowering the peak flame temperature. In these embodiments, oxygen 107 may be mixed with second fluid 105 in chamber 111, before chamber 111, or staged so that a portion of oxygen 107 is mixed with convective section 106.

[0038] In addition, injection of second fluid 105 may be substantially bounded by oxygen 107 and/or a flue gas recycle stream to provide a thermal radiation buffer to protect heat exchangers 120 in convection section 106. Such injection may be controllably provided so as to better handle changes in conditions in convective section 106. As further protection, a region immediately bounding a convective combustion zone (i.e. the combustion zone in convective section 106) near inlet devices 112 may include a heat sink, such as water cooled tubes 501 (see FIG. 5), recycled flue gas, or refractory that can handle high heat fluxes and protect heat exchangers 120 of convective section 106 from the intense flame radiation (see FIG. 5). Alternatively, the heat injection may be accomplished by combusting second fluid 105 before injection into

system 102 and then injecting the hot combustion products (see FIG. 2). In further embodiments, as illustrated in FIG. 5, the system may controllably vary flow rates to one or all inlet devices 112 to improve efficiency or may controllably vary flow rates of fluid in the water tubes to better protect the heat exchangers. For example, valves 503 and a control system 505 may be included to modify the flow of any fluid, for example, oxygen, flue gas, flue gas mixed with oxygen, and/or fuel. In addition, sensors for monitoring physical conditions, such as thermocouples for monitoring temperature, may be included in system 102 and utilized by the control system.

[0039] FIG. 4 shows this combustion occurring immediately before entry into convective section 106, but the combustion may also take place further away from the convection section and may even occur in a centralized location as shown in FIG. 2. The arrangement illustrated in FIG. 4 may protect inlet devices 112 from combustion fluid, which may be corrosive, erosive, and/or oxidative. Additionally, recesses 111 may be cooled to maintain inlet devices 112 at a desired temperature, which may be below the temperature of convective section 106. Similar to the above features, these features may be controlled for improved efficiency.

[0040] FIG. 5 illustrates combustion system 102 configured in a manner similar to the configuration of FIGS. 1 through 3; however, in FIG. 5, combustion system 102 includes water cooled tubes 501 bounding the convective combustion zone corresponding with inlet devices 112. As illustrated in FIG. 5, water cooled tubes 501 are arranged and disposed to transfer heat produced by combustion of the mixture of the second fluid and oxygen 107 to a heat exchange medium (not shown). The heat exchange medium may be water, for example.

[0041] In the embodiments illustrated by FIGS. 1 through 5, the position of inlet devices 112 exemplary and may be modified based upon heat duty required for the different parts of the steam cycle.

[0042] Arranging water cooled tubes 501 around the convective combustion zone corresponding with inlet devices 112 or extracting heat from the solid fuel conversion mechanism may also modify the heat distribution within combustion system 102. The heat duty transferred from furnace 104 may be reduced by the amount of duty transferred by water cooled tubes 501 and the heat transferred from the fuel conversion mechanism.

[0043] Increasing flow in one or more inlet device 112 and/or decreasing flow in one or more inlet devices 112 shifts some of the firing duty from furnace 104 to convection section 106. Such shifting may change the heat and material balance for the combustion system 102. In other embodiments, the positions and arrangements of inlet devices 112 illustrated by FIGS. 1 through 5 can be combined to increase efficiency. For example, one inlet device 112 may be recessed (similar to the embodiment illustrated by FIG. 4), while another inlet device 112 may have water cooled tubes 501 nearby (similar to the embodiment illustrated by FIG. 5), and/or while another inlet device 112 may be positioned without being recessed and without having water cooled tubes 501 nearby (similar to the embodiments illustrated by FIGS. 1 through 3). Additionally, fewer or more inlet devices 112 may be included. As will be appreciated, to maximize efficiency, multiple tests on combustion system 102 and/or modeling of combustion system 102 may be performed thereby providing design parameters



with improved efficiency. Such design parameters may involve other combinations of these.

#### EXAMPLES

**[0044]** In the embodiments illustrated by FIGS. 1 through 5, three inlet devices are shown. The position of these inlet devices represent different possible locations within the convection section. The placement of the inlet devices depends upon the heat duty required for the different parts of the steam cycle. A heat and material balance was performed using the coal described in Table 1 to determine a possible firing rate split for the different locations of inlet devices. Table 1 details the analysis of a typical high volatile bituminous coal used in the example.

TABLE 1

Coal Analysis		
Coal Characteristics for a Typical High Volatile Bituminous Coal		
Proximate Analysis, wgt %	H <sub>2</sub> O	2.5
	Volatile Matter	37.6
	Fixed Carbon	52.9
	Ash	7
Ultimate Analysis, wgt %	H <sub>2</sub> O	2.5
	C	75
	H	5
	S	2.3
	O	6.7
	N	1.5
HHV, BTU/lb		13000

**[0045]** In this example, the fuel source for the inlet devices in the convective section were assumed to contain 50% of the volatiles from the coal and 18.8% of the total heating value of the coal. In this example, the combined oxidant and fuel carrier gas stream consisted of 80% O<sub>2</sub> and 20% CO<sub>2</sub>. The convective section fuel injection was split 10%, 65%, and 25% between the inlet devices, respectively along the flow path of the combustion fluid. The temperature was estimated at about 2900° F. (about 1593° C.) exiting the furnace, 2400° F. (about 1316° C.) between the first two inlet devices, and 1950° F. (about 1066° C.) between the second and third inlet devices, and 670° F. (about 354° C.) after the final inlet device. Due to the low level of flue gas recycle, the average convective section temperature was higher than that available with a traditional system design. This higher temperature led to a greater temperature difference driving force for heat transfer which therefore lowered the heat transfer surface area required in the convective section for similar duty.

**[0046]** The burners and heat injection in the convective section may be used in a steady-state or transient condition. For example, the inlet devices may be used mainly in a start-up mode to bring the steam conditions to the requirements of the steam process as soon as possible. This is especially important for a combustion system designed to operate using large amounts of flue gas recycle to achieve the proper heat distribution within the system. During start-up before sufficient flue gas recycle is available, the inlet devices in the convection section may be used to achieve the proper convective section heat transfer.

**[0047]** While the disclosure has been described with reference to a preferred embodiment, it will be understood by those skilled in the art that various changes may be made and equivalents may be substituted for elements thereof without departing from the scope of the disclosure. In addition, many

modifications may be made to adapt a particular situation or material to the teachings of the disclosure without departing from the essential scope thereof. Therefore, it is intended that the disclosure not be limited to the particular embodiment disclosed as the best mode contemplated for carrying out this disclosure, but that the disclosure will include all embodiments falling within the scope of the appended claims.

What is claimed is:

1. An oxy/fuel combustion system comprising:
  - a furnace arranged and disposed to receive and combust a first fuel with oxygen to form a combustion fluid, the first fuel provided from a first solid fuel source;
  - a convective section having an inlet device, the convective section arranged to receive the combustion fluid from the furnace and disposed to receive a second fluid, the second fluid converted from a second fuel, the second fuel being a solid fuel; and
  - one or more heat exchangers in the convective section arranged and disposed to transfer heat from the combustion fluid to a heat exchange medium.
2. The system of claim 1, wherein the inlet device is arranged and disposed to receive the oxygen.
3. The system of claim 1, wherein the inlet device is recessed from the convective section.
4. The system of claim 1, further comprising a solid fuel conversion mechanism selected from the group consisting of a fluidized bed, a gasifier, a combustor, an additional burner, a micronizing pulverizer, and combinations thereof, wherein the solid fuel conversion mechanism is arranged and disposed to convert the second solid fuel into at least a portion of the second fluid.
5. The system of claim 1, wherein the first fuel includes coal.
6. The system of claim 1, wherein the second fluid includes micronized coal.
7. The system of claim 1, wherein the second fluid includes a volatilized fuel.
8. The system of claim 5, wherein the volatilized fuel is generated by mixing the second fuel with a recycled flue gas.
9. The system of claim 1, wherein the conversion mechanism is a gasifier arranged and disposed for the oxygen to oxidize the second fuel.
10. The system of claim 9, wherein the gasifier is a slagging gasifier.
11. The system of claim 1, wherein the conversion mechanism is a combustor.
12. The system of claim 1, wherein the first fuel is a solid fuel.
13. The system of claim 1, wherein the first solid fuel source is arranged and disposed for providing the second solid fuel source.
14. The system of claim 1, further comprising a conversion mechanism selected from the group consisting of a fluidized bed, a gasifier, a combustor, an additional burner, a micronizing pulverizer, and combinations thereof, the conversion mechanism in communication with the first solid fuel source thereby converting the first fuel prior to the first fuel being received by the furnace.
15. The system of claim 1, further comprising water cooled tubes bounding a convective combustion zone corresponding with the inlet devices, wherein the water cooled tubes provide heat transfer protecting at least one of the one or more of the heat exchangers.



**16.** The system of claim **1**, further comprising a control system arranged and disposed for modifying the flow rate of the second fluid.

**17.** An oxy/fuel combustion method comprising:  
providing a furnace and a convective section, the furnace in fluid communication with the convective section;  
providing a first fuel from a first solid fuel source;  
receiving the first fuel in the furnace;  
combusting the first fuel in the furnace thereby producing a combustion fluid;  
receiving the combustion fluid in the convective section;  
converting a second fuel into a second fluid, the second fuel being a solid fuel;  
receiving the second fluid in a convective section; and  
transferring heat from the combustion fluid to a heat exchange medium.

**18.** The method of claim **17**, further comprising converting the second fuel to the second fluid by a fluidized bed.

**19.** The method of claim **17**, further comprising converting the second fuel to the second fluid by a gasifier.

**20.** The method of claim **17**, further comprising converting the second fuel to the second fluid by a combustor.

**21.** The method of claim **17**, further comprising converting the second fuel to the second fluid by an additional burner.

**22.** The method of claim **17**, further comprising converting the second fuel to the second fluid by a micronizing pulverizer.

**23.** The system of claim **1**, further comprising controlling the flow rate of the second fluid by a control system.

\* \* \* \* \*