

US 20100034692A1

(19) **United States**

(12) **Patent Application Publication**
Feng et al.

(10) **Pub. No.: US 2010/0034692 A1**

(43) **Pub. Date: Feb. 11, 2010**

(54) **NICKEL-BASE SUPERALLOY,
UNIDIRECTIONAL-SOLIDIFICATION
PROCESS THEREFOR, AND CASTINGS
FORMED THEREFROM**

Publication Classification

(51) **Int. Cl.**
C22C 19/05 (2006.01)
C22F 1/10 (2006.01)
B22D 30/00 (2006.01)

(75) Inventors: **Ganjiang Feng**, Greenville, SC (US); **Shyh-Chin Huang**, Latham, NY (US); **Jian Zheng**, Greenville, SC (US)

(52) **U.S. Cl.** **420/448; 420/445; 148/555**

(57) **ABSTRACT**

An alloy composition and method by which the incidence of freckling can be reduced in castings produced with properties similar to the René N5 nickel-base superalloy. The casting has a unidirectional crystal structure and a composition consisting of, by weight, 6% to 8% chromium, 6% to 9% cobalt, 0% to 2% molybdenum, 4% to 6% tungsten, 6.4% to 6.9% tantalum, 0% to 2% titanium, 5% to 7% aluminum, 2.7% to 3.0% rhenium, 0.3% to 0.7% hafnium, 0.04% to 0.08% carbon, 0.002% to 0.006% boron, 0% to 0.075% yttrium, 0.002% to 0.004% zirconium, the balance being nickel and incidental impurities.

Correspondence Address:
Hartman & Hartman, P.C.
552 E. 700 N.
Valparaiso, IN 46383 (US)

(73) Assignee: **General Electric Company**, Schenectady, NY (US)

(21) Appl. No.: **12/187,049**

(22) Filed: **Aug. 6, 2008**

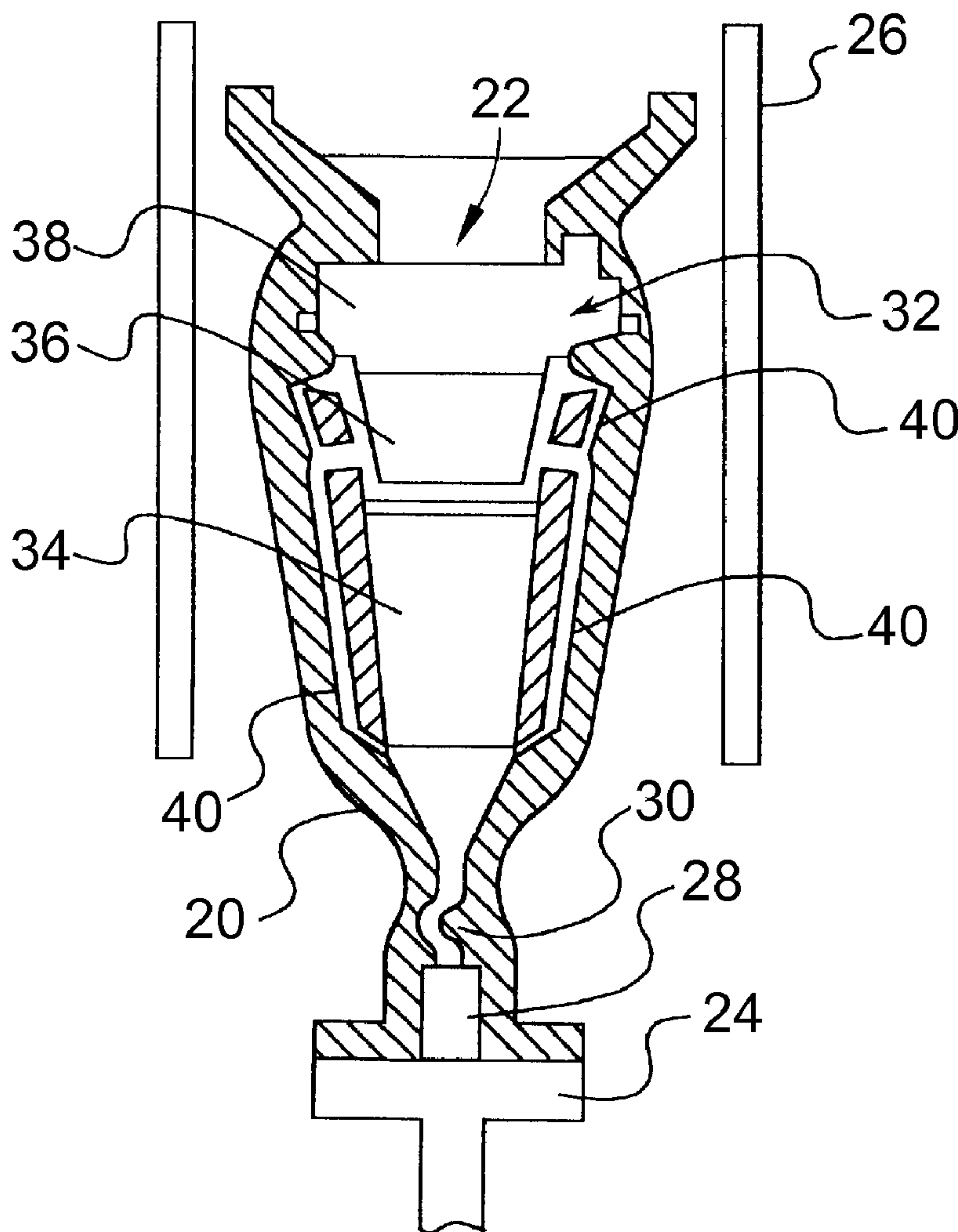

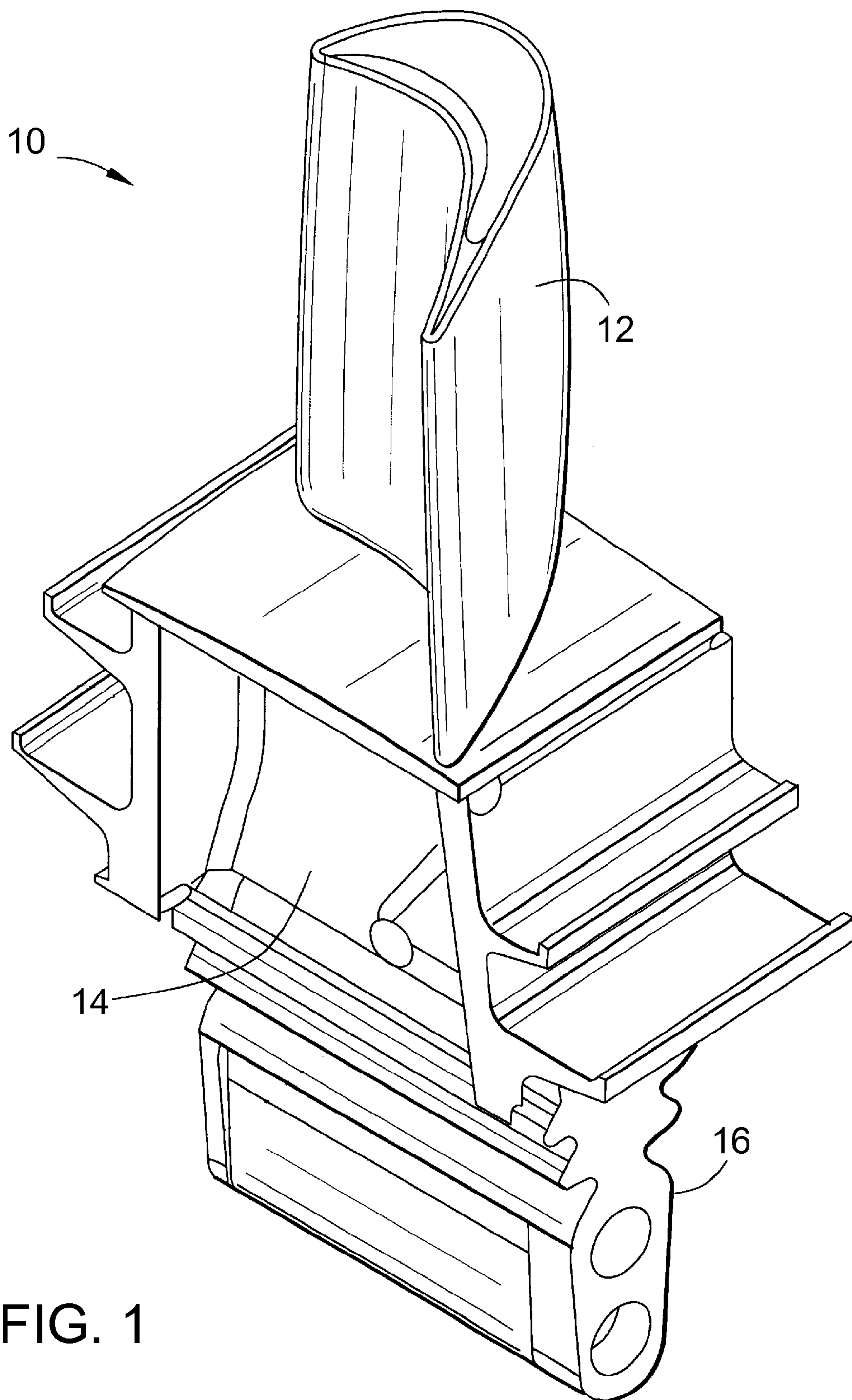

FIG. 1

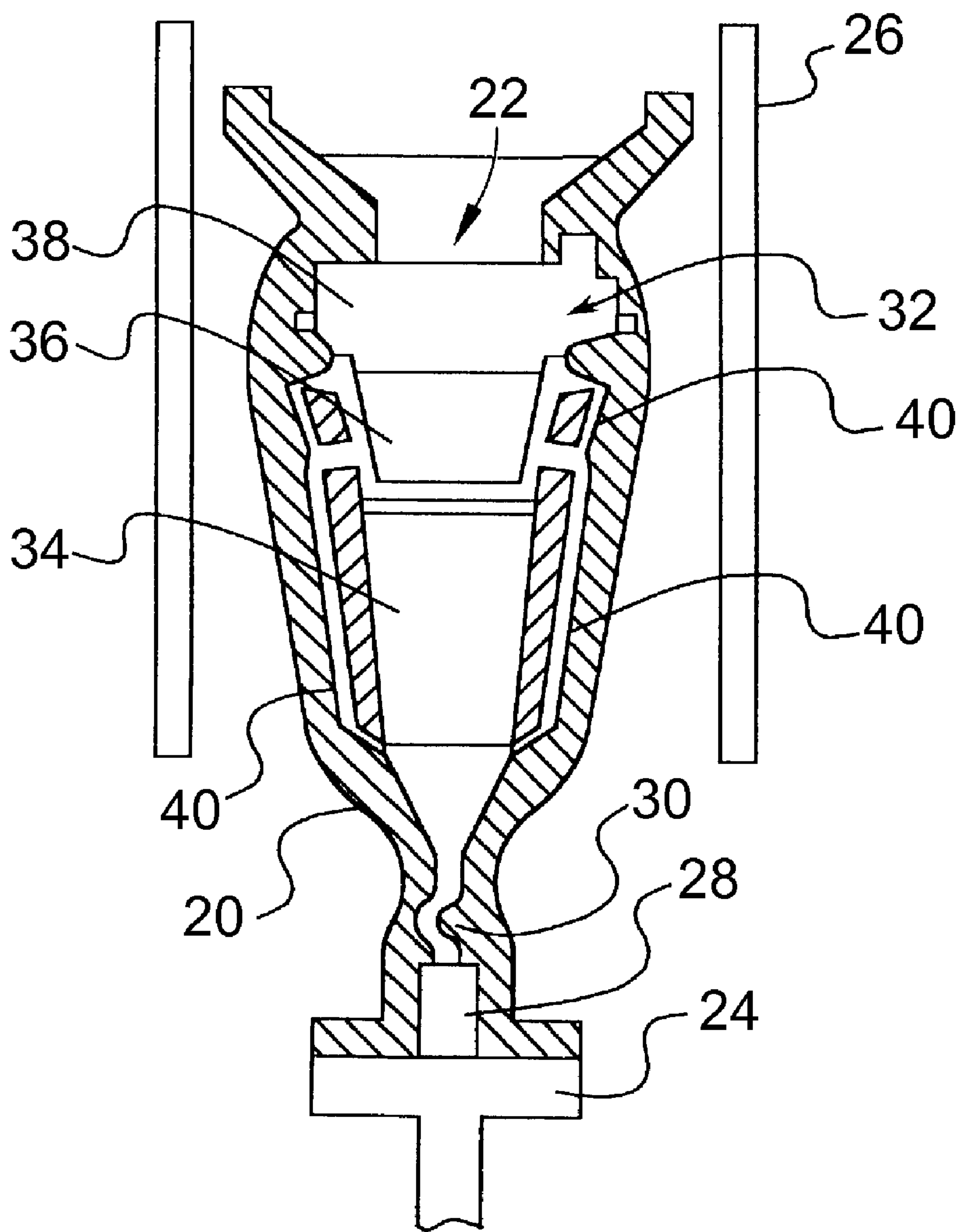

FIG. 2

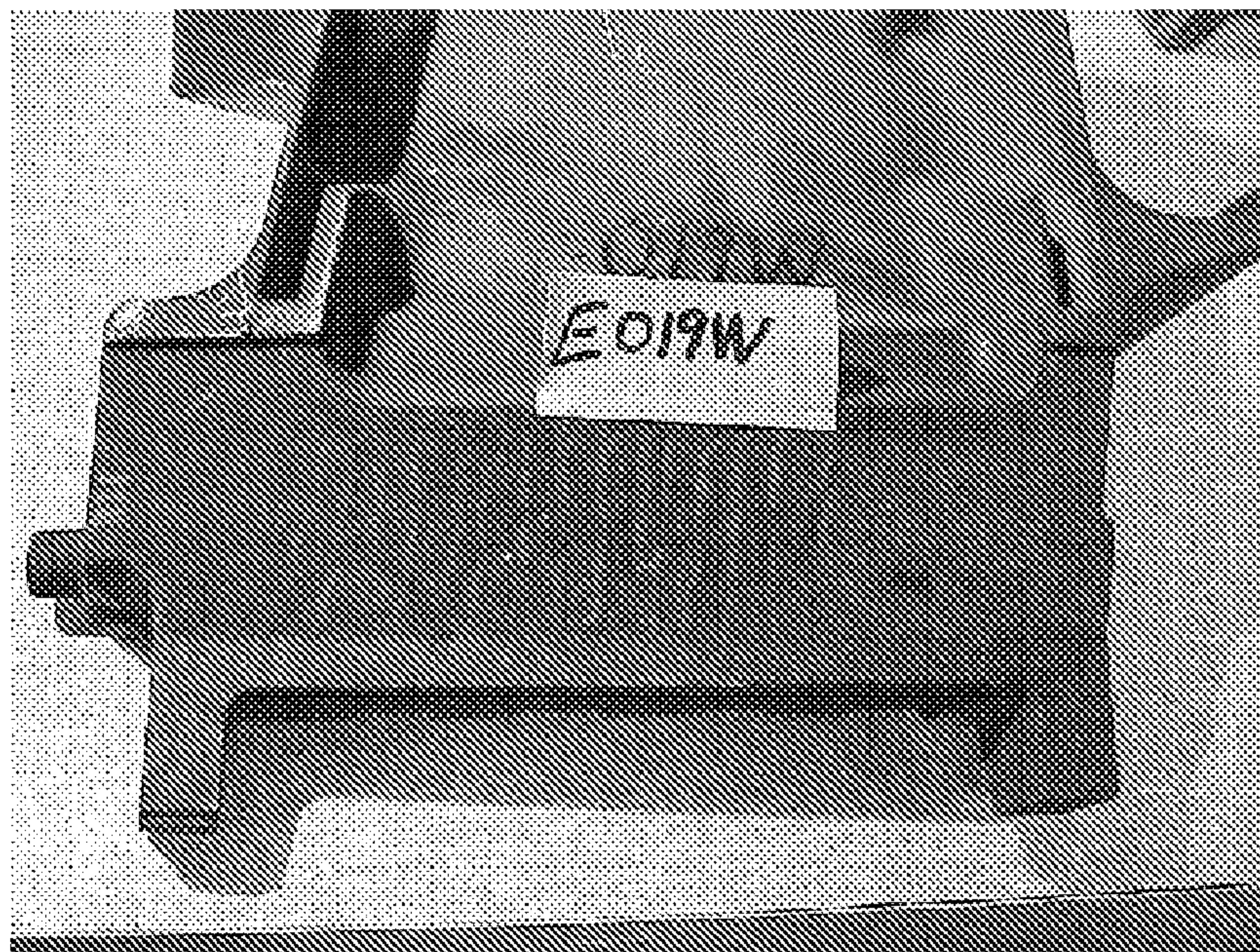

FIG. 3

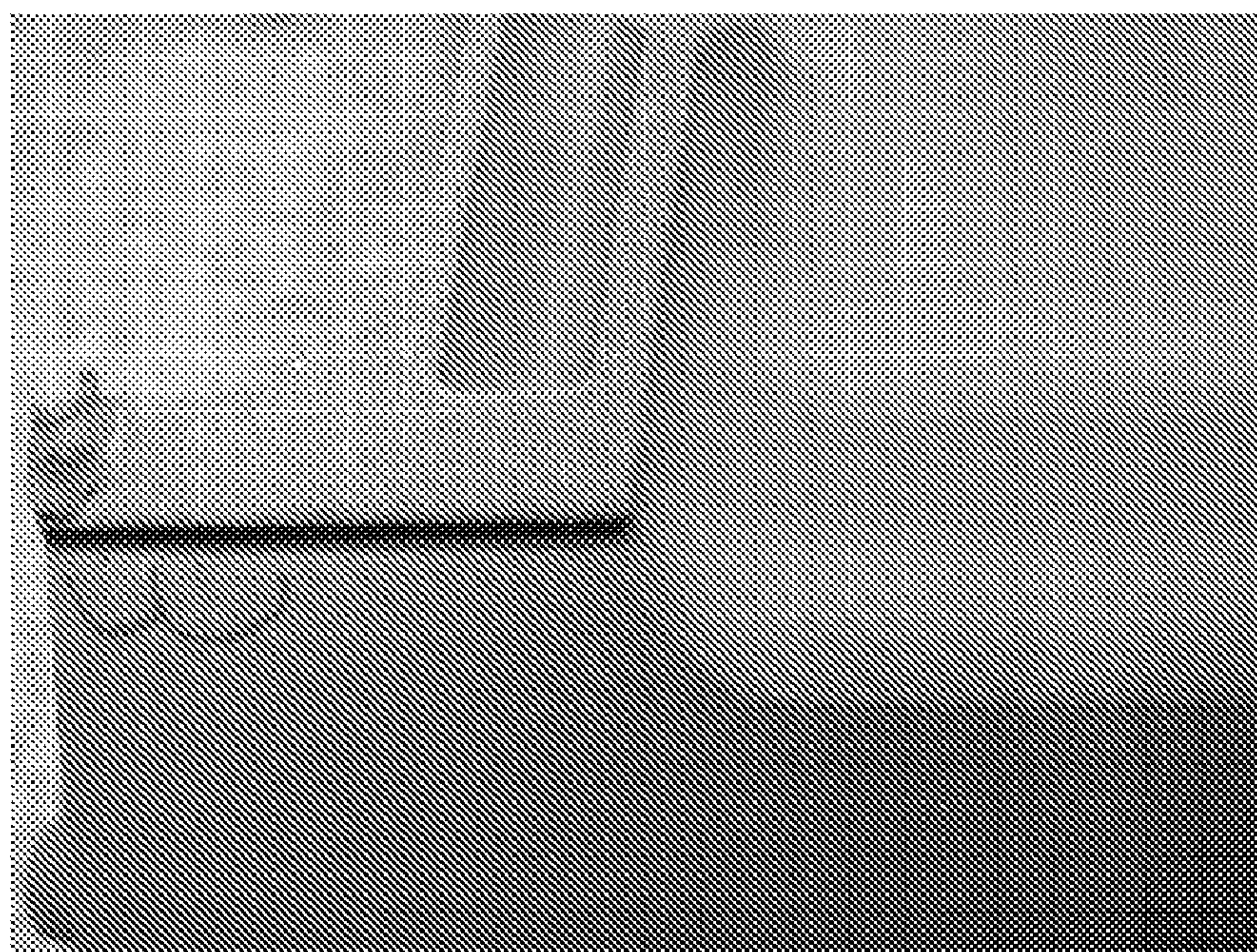

FIG. 4

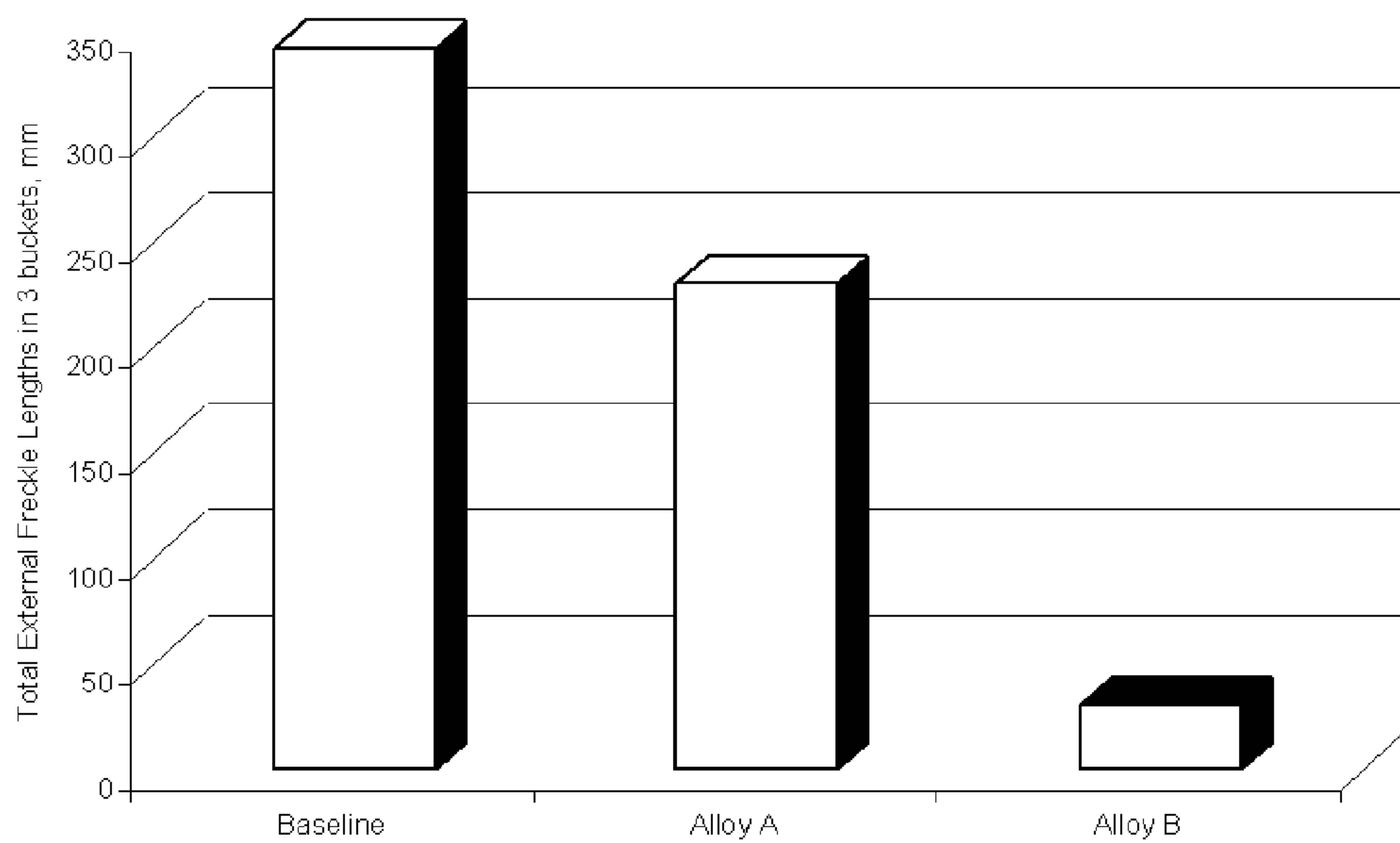

FIG. 5

**NICKEL-BASE SUPERALLOY,
UNIDIRECTIONAL-SOLIDIFICATION
PROCESS THEREFOR, AND CASTINGS
FORMED THEREFROM**

BACKGROUND OF THE INVENTION

[0001] The present invention generally relates to nickel-base superalloy compositions and processes for producing directionally-solidified castings therefrom. More particularly, the invention is directed to a nickel-base superalloy that is castable as single-crystal articles suitable for use as components of gas turbines and other high temperature applications.

[0002] Components of gas turbines, such as blades (buckets), vanes (nozzles) and combustor components, are typically formed of nickel, cobalt or iron-base superalloys characterized by desirable mechanical properties at turbine operating temperatures. Because the efficiency of a gas turbine is dependent on its operating temperatures, there is an ongoing effort to develop components, and particularly turbine buckets, nozzles, and combustor components, that are capable of withstanding higher temperatures. As the material requirements for gas turbine components have increased, various processing methods and alloying constituents have been used to enhance the mechanical, physical and environmental properties of components formed from superalloys. For example, buckets, nozzles and other components employed in demanding applications are often cast by unidirectional casting techniques to have directionally-solidified (DS) or single-crystal (SX) microstructures, characterized by a crystal orientation or growth direction in a selected direction to produce columnar polycrystalline or single-crystal articles.

[0003] Mechanical properties of DS and SX articles depend in part on the avoidance of high-angle grain boundaries, equiaxed grains, and defects resulting from interdendrite segregation during the directional solidification process. As an example, depending on the particular chemistry of the superalloy, interdendrite segregation can result in the formation of surface freckles, which form during solidification as chains of very small equiaxed grains, with typical chain lengths of about 0.25 inch (about 6 mm) up to a few inches (about 50+ mm) in length. Such defects can reduce fatigue life and act as grain initiators during the solidification process that cause unacceptable off-axial grains. Casting process parameters such as withdraw rate, cooling speed, and the solid-liquid interface position appear to have an effect on freckle formation. As such, prior efforts to eliminate freckle formation have included process-related techniques; for example, high-gradient casting technologies have been shown to have a strong effect on freckle reduction as disclosed in commonly-assigned U.S. Pat. No. 6,217,286 to Huang et al. The tendency for freckling is also dependent on composition, an example being the level of tantalum in the superalloy. Consequently, freckling has also been addressed through careful control or modifications of the superalloy composition, as reported in commonly-assigned U.S. Pat. Nos. 5,151,249, 6,091,141 and 6,909,988.

[0004] The nickel-base superalloy commercially known as René N5, disclosed in commonly-assigned U.S. Pat. No. 6,074,602, has a composition of, by weight percent, about 5-10 chromium, about 5-10 cobalt, about 0-2 molybdenum, about 3-10 tungsten, about 3-8 tantalum, about 0-2 titanium, about 5-7 aluminum, about 0-6 rhenium, about 0-0.50 hafnium, about 0-0.07 carbon, about 0-0.015 boron, and

about 0-0.075 yttrium, the balance being nickel and incidental impurities. As with the formulation of other superalloys, the composition of N5 is characterized by controlled concentrations of certain critical alloying elements to achieve a desired mix of properties. When cast as single-crystal components for use in gas turbine applications, including high pressure turbine buckets and nozzles, such properties include high temperature creep strength, oxidation and corrosion resistance, resistance to low and high cycle fatigue (LCF and HCF), and single-crystal castability. While N5 performs extremely well in applications within gas turbines, buckets and nozzles cast from N5 can exhibit external and internal freckle chains. Because excessive freckling can necessitate scrapping of a casting, there is a desire to reduce the incidence and level of freckling exhibited by the N5 alloy.

BRIEF DESCRIPTION OF THE INVENTION

[0005] The present invention provides an alloy composition and method by which the incidence of freckling can be reduced in a unidirectionally-solidified casting having properties similar to unidirectionally-solidified castings produced from the N5 nickel-base superalloy.

[0006] According to a first aspect of the invention, a nickel-base superalloy is provided that is particularly suitable for producing castings with unidirectional crystal structures. The superalloy has a composition consisting of, by weight, 6% to 8% chromium, 6% to 9% cobalt, 0% to 2% molybdenum, 4% to 6% tungsten, 6.4% to 6.9% tantalum, 0% to 2% titanium, 5% to 7% aluminum, 2.7% to 3.0% rhenium, 0.3% to 0.7% hafnium, 0.04% to 0.08% carbon, 0.002% to 0.006% boron, 0% to 0.075% yttrium, 0.002% to 0.004% zirconium, the balance being nickel and incidental impurities.

[0007] According to a second aspect of the invention, a method is provided for producing the nickel-base superalloy as a unidirectionally-solidified casting. The method generally entails pouring a molten quantity of the composition into a heated zone of a preheated mold comprising a main cavity having the shape of the cast article, withdrawing the mold from the heated zone into a cooling tank to directionally solidify the molten metal, and then cooling the mold to produce the casting and a unidirectional crystal structure.

[0008] According to a preferred aspect of the invention, the unidirectional crystal structure of the casting is substantially free of freckle defects. As used herein, the characterization of a casting being substantially free of freckles is meant to indicate a total combined length of all freckles of not more than 0.5 inch (about 12 mm). A significant advantage of this invention is that, though the composition of the casting contains the same alloying constituents as N5 and the alloying levels of these constituents are within or overlap the broadest ranges disclosed for N5, it has been determined that the employment of particular levels and relative proportions of these constituents are able to produce unexpected superior results as compared to the N5 alloy processed under identical conditions. In particular, the reduction in the incidence of freckling is greater than was expected for composition modifications alone, and the result is the absence of freckling that would otherwise be an expected property for N5 under the same processing conditions.

[0009] According to another preferred aspect of the invention, the unidirectional crystal structure of the casting is a single crystal with a preferred single crystal direction of $\langle 001 \rangle$, though crystalline structures having orientations other than $\langle 001 \rangle$ are also within the scope of the invention.

Finally, the alloy composition and castings that can be produced in accordance with the invention are well suited for components of a gas turbine, such as buckets, nozzles, and other components of gas turbines.

[0010] Other objects and advantages of this invention will be better appreciated from the following detailed description.

BRIEF DESCRIPTION OF THE DRAWINGS

[0011] FIG. 1 depicts a turbine bucket that can be formed from the nickel-base superalloy of the present invention.

[0012] FIG. 2 is a represents a cross-sectional view of a mold for casting a large single-crystal component in accordance with an embodiment of this invention.

[0013] FIGS. 3 and 4 are scanned images showing external freckle chains on the surfaces of buckets formed from alloys whose compositions are, respectively, in accordance with the production specification for René N5 and modified in accordance with an embodiment of the present invention.

[0014] FIG. 5 is a graph plotting freckle length measurement data obtained from buckets cast from an alloy whose compositions is in accordance with the production specification for René N5 and from two alloys modified in accordance with embodiments of the present invention.

DETAILED DESCRIPTION OF THE INVENTION

[0015] The present invention was the result of an effort to develop a nickel-base alloy having properties similar to the nickel-base alloy commercially known as René N5, but with a chemistry that reduces the tendency for freckling while maintaining the mechanical properties of the alloy, such as high temperature strength (including creep resistance), oxidation resistance, fatigue resistance, castability, and microstructural stability for use in such applications as the hot gas flow path of a gas turbine. As an example, FIG. 1 depicts a first stage bucket 10 for a land-based gas turbine, such as the H and FB class gas turbines used in the power-generating industry and manufactured by the assignee of the invention. The bucket 10 has an airfoil 12 and shank 14, with a dovetail 16 formed on the shank 14 for anchoring the bucket 10 to a turbine disk (not shown). As is common with turbine buckets, the bucket 10 is preferably unidirectionally cast to have a columnar single crystal (SX) or columnar polycrystalline (DS) microstructure. While the advantages of this invention will be described with reference to components of a gas turbine, such as the bucket 10 shown in FIG. 1, the teachings of this invention are generally applicable to other components that benefit from being cast from a high-temperature material such as N5.

[0016] As known in the art, freckles form in part as a result of molten metal convection in the casting mold which disrupts unidirectional solidification processes, producing irregularities seen on SX and DS casting surfaces as little chains of equiaxed crystals. Freckles can act as grain initiators during the solidification process that cause unacceptable off-axial grains, and may reduce fatigue life of the casting. According to a preferred and unexpected aspect of the invention, external and internal freckling can be inhibited and even eliminated in an alloy whose constituent levels fall within the ranges disclosed for N5 levels in U.S. Pat. No. 6,074,602, the contents of which relating to composition of the N5 alloy are incorporated herein by reference. Furthermore, the alloy can be used to produce large castings that are typically more prone to freckling, including the large turbine buckets of

land-based gas turbines such as that of FIG. 1, whose overall lengths are often in the range of about fifteen to about forty inches (about forty to about one hundred centimeters).

[0017] The compositional modifications to the nickel-base N5 superalloy that achieve the reduction in freckling were initially based on data generated from a modeling technique, through which correlations were identified and analyzed regarding the overall effect of each element of the N5 alloy on freckle formation. Broad ranges disclosed in U.S. Pat. No. 6,074,602 for N5 are summarized in Table I below.

TABLE I

Constituent	Weight Percent
Chromium	5-10%
Cobalt	5-10%
Molybdenum	0-2%
Tungsten	3-10%
Tantalum	3-8%
Titanium	0-2%
Aluminum	5-7%
Rhenium	0-6%
Carbon	0-0.07%
Hafnium	0-0.5%
Boron	0-0.015%
Yttrium	0-0.075%
Nickel	Balance

[0018] Through this modeling, certain alloying constituents and certain combinations of constituents were predicted to have a strong affect on freckle formation, while others were predicted to have a lesser or essentially no affect. In particular, the modeling technique was used to quantify the effect of each alloying constituent on freckle formation, using what will be termed here the Freckle Susceptibility Index, R_e , defined by the following equation:

$$R_e = A(VG)^{-1} \sum (P_i C_{0,i})$$

where A is a constant, V and G are casting process factors (respectively, withdraw rate and thermal gradient), and P_i and $C_{0,i}$ are chemistry factors (respectively, a convection potency factor for each element i and the initial concentration of each element i). The convection potency factor is a factor developed for use in the modeling technique, and takes into account several variables, including the slope of the liquidus line in the phase diagram, the segregation coefficient, solutal volume expansion coefficient, and thermal volume expansion coefficient. From the equation, it can be seen that elements with a negative convection potency factor (P_i) reduce the value of the Freckle Susceptibility Index, R_e , and therefore are expected to reduce the risk of freckling, whereas elements with a positive P_i value increase R_e and are therefore expected to increase the risk of freckling. P_i values for various elements of N5 are listed in Table II below:

TABLE II

Constituent	P_i Value
Chromium	16
Cobalt	0
Molybdenum	0
Tungsten	24
Tantalum	-16
Columbian	-22
Titanium	29
Aluminum	12
Rhenium	31

TABLE II-continued

Constituent	P_i Value
Carbon	-467
Hafnium	-12768
Zirconium	4522

[0019] Based on the equation for calculating R_e values using the P_i values of Table II, it can be seen that hafnium should have the strongest influence on freckle formation, and also the greatest beneficial effect on freckle prevention if present at sufficiently high levels. Tantalum and carbon also have beneficial effects, though not as pronounced as hafnium. On the other hand, aluminum, tungsten, and rhenium are expected to have a moderate detrimental effect due to their moderate P_i values in combination with their significant alloying levels in the N5 alloy. Other elements, including cobalt, chromium, titanium, niobium, and molybdenum should have negligible effects, either because of their low P_i values (cobalt, chromium, and molybdenum) or their very low amounts in N5 (titanium and columbium). Though an impurity in N5, the very high P_i value for zirconium suggests that it may also have a detrimental effect on freckling within the typically allowed range of up to 0.01 weight percent in the N5 alloy.

[0020] Independent of the process parameters, the influence that any one element might have on the Freckle Susceptibility Index, R_e , can be predicted based on the product of its convection potency factor, P_i , and its concentration tolerance (ΔC_i) in the production specification for the N5 alloy. For example, this product for hafnium is $-12768 \times 0.06 = -766$, evidencing a very strong positive affect. The same calculation indicates that tantalum (-3) and carbon (-5) should have moderate positive affects, rhenium (8), tungsten (6), and aluminum (2) should have moderate negative affects, and cobalt, chromium, and molybdenum should have negligible affects (approximately 0), as will titanium, columbium, and zirconium if present as impurities. On the other hand, zirconium may significantly promote freckling within the typically allowed range of up to 0.01 weight percent ($4522 \times 0.005 = 23$).

[0021] The extent to which a given constituent promoted or inhibited freckling influenced the targeted level for that constituent in the alloy, and consequently the nickel-base alloy of the present invention nominally contains more hafnium, tantalum and carbon and less rhenium, tungsten, aluminum, and zirconium than the nominal N5 composition. Because tantalum and aluminum are both gamma prime (Ni_3X) formers, a lower level of aluminum can be offset by the higher level of tantalum to maintain the gamma prime content desired for N5. However, rhenium and tungsten are both solid solution strengtheners, and as such attempts to offset reductions in both of these elements must be by increasing another solid solution strengthener in order to maintain the desirable properties of N5. As will be discussed below, experiments conducted to verify the predictions of the modeling technique suggested that the influence of hafnium may be sufficiently strong to eliminate freckling if hafnium levels exceed the hafnium upper limit for N5 (0.50 weight percent).

[0022] According to the invention, the nickel-base alloy has the following broad, preferred, and nominal compositions, by weight.

TABLE III

Constituent	Broad Range	Preferred Range	Nominal
Chromium	6 to 8%	6.75 to 7.25%	7%
Cobalt	6 to 9%	7 to 8%	7.5%
Molybdenum	0 to 2%	1.3 to 1.7%	1.5%
Tungsten	4 to 6%	4.5 to 5.0%	4.75%
Tantalum	6.4 to 6.9%	6.5 to 6.8%	6.7%
Titanium	0 to 2%	0 to 0.05%	0 to 0.02%
Aluminum	5 to 7%	6.0 to 6.2%	6.1%
Rhenium	2.7 to 3.0%	2.75 to 2.9%	2.8%
Carbon	0.04 to 0.08%	0.05 to 0.07%	0.06%
Hafnium	0.3 to 0.7%	0.4 to 0.6%	0.5%
Boron	0.002 to 0.006%	0.003 to 0.005%	0.004%
Yttrium	0 to 0.075%	0 to 0.075%	0 to 0.03%
Zirconium	0.002 to 0.004%	0.002 to 0.003%	0.0025%

The balance of the alloy is nickel and incidental impurities. Aside from freckling reduction, the alloy of this invention preferably has essentially the same properties as, and potentially superior properties to, the N5 alloy, and therefore provides an excellent alternative to N5.

[0023] As noted above, based on the above modeling technique and subsequent casting experiments, upper and lower limits of certain constituents in Table III are higher or lower than the production specification ranges for the N5 alloy of Table I. Though the alloying ranges of these alloying constituents are within or overlap the broadest ranges disclosed for N5, these ranges are very narrowly tailored to avoid the incidence and degree of freckling that has previously not been controlled. In view of the complexity of the N5 alloy and the interactions of its constituents, the reduction in freckling was viewed as unpredictable prior to the teachings of the present invention. Furthermore, it was unexpected that an alloy with specific constituent levels within the broad ranges taught for the N5 alloy could exhibit substantially reduced freckling as compared to other alloy chemistries within the N5 composition ranges and processed under identical conditions. Notably, certain elements noted in the past as inhibiting freckling, for example, carbon, must be limited to a low and narrow range in N5 to ensure the attainment of certain mechanical properties.

[0024] Components of the alloy having SX or DS microstructures can be produced by generally conventional casting unidirectional casting techniques. For example, single-crystal castings are produced from a melt of the alloy, for example, prepared by known vacuum induction melting techniques. As known in the art, heat transfer conditions during the solidification of the casting are controlled so that one section of the casting article does not cool faster than the rest of the casting to avoid the nucleation and formation of secondary grains from the melt in competition with the primary columnar single crystal. Secondary and multi-grains are further controlled by adjusting the heat transfer conditions during the withdrawal of the mold into a cooling bath or radiation cooling zone to ensure that all parts of the casting cool at approximately the same rate.

[0025] FIG. 2 represents a shell mold 20 of a type suitable for producing a single-crystal casting of the alloy of this invention. As known in the art, the mold 20 is preferably formed of a material such as alumina or silica, and has an internal cavity 22 corresponding to the desired shape of a casting 32, represented as a turbine bucket similar to that of FIG. 1. As such, the cavity 22 is configured to produce the casting 32 with an airfoil portion 34, shank 36, and dovetail

38. The mold **20** is shown secured to a chill plate **24** and placed in a heating zone **26** to heat the mold **20** to a temperature equal to or above the melting temperature of the alloy, and more particularly above the liquidus temperature of the alloy (about 1397° C.). The casting process is preferably carried out in a vacuum or an inert atmosphere. The molten alloy is poured into the preheated mold **20**, after which unidirectional solidification is initiated by withdrawing the base of the mold **20** and chill plate **24** downwardly at a fixed rate to a cooling zone (not shown), which may contain a liquid metal cooling bath or a vacuum or ambient or cooled air for radiation cooling. The casting **32** grows epitaxially (for example, with the <100> orientation) based on the crystalline structure and orientation of a small block of single-crystal seed material **28** at the base of the mold **20**, from which a single crystal forms from a crystal selector **30**. The columnar single crystal becomes larger in the enlarged section of the cavity **22**. A bridge **40** connects protruding sections of the casting **32** with lower sections of the casting **32** so that a unidirectional columnar single crystal forms substantially throughout the casting **32**. The casting **32** is deemed to be a substantially columnar single crystal if more than 50% of the casting is single crystal. Those skilled in the art will appreciate that a DS casting can be produced in a similar manner, though with modifications to the mold **20**, such a growth zone at the base of the mold **20** that is open to the chill plate **24**, and omission of the crystal selector **30**.

[0026] In the experiments used to verify the predictions of the modeling technique, nine stage 1 buckets were prepared for the 9FB class gas turbines manufactured by the assignee of the invention. The compositions of the buckets were formulated on the basis of data generated from the aforementioned modeling technique, by which the overall effect of each element of N5 on freckle formation was predicted. Targeted chemistries were then proposed, taking into consideration those elements believed to have a strong effect on freckle formation, as well as those believed to have a less effect. Two experimental compositions, Alloy A and Alloy B, were evaluated, along with an alloy formulated to have a baseline N5 chemistry ("Baseline Alloy"). As evident from Table IV below, Alloys A and B were substantially identical to the Baseline Alloy except for their levels of tungsten (which differed by only 0.15% from the Baseline), tantalum (which differed by only 0.24% or 0.25% from the Baseline), aluminum (which differed by only 0.15% from the Baseline), rhenium (which differed by only 0.11% and 0.13% from the Baseline), hafnium (which differed by only 0.06% or 0.36% from the Baseline), and zirconium (which differed by only 0.004% from the Baseline). Nonetheless, it will be seen that these small changes in chemistry had a significant impact on the incidence of freckling in their respective alloys.

TABLE IV

Constituent	Baseline Alloy	Alloy A	Alloy B
Chromium	7.12%	7.10%	7.10%
Cobalt	7.42%	7.42%	7.41%
Molybdenum	1.44%	1.42%	1.42%
Tungsten	4.90%	4.75%	4.75%
Tantalum	6.44%	6.68%	6.69%
Titanium	0.02%	0.02%	0.02%
Aluminum	6.20%	6.05%	6.05%
Rhenium	2.91%	2.80%	2.78%
Carbon	0.058%	0.058%	0.058%
Hafnium	0.14%	0.20%	0.50%

TABLE IV-continued

Constituent	Baseline Alloy	Alloy A	Alloy B
Boron	0.004%	0.004%	0.004%
Zirconium	0.007%	0.003%	0.003%
Nickel	Balance	Balance	Balance

[0027] Three single-crystal castings of each alloy composition were prepared in accordance with commercial practices for N5, generally in accordance with the casting process described above, as well as a heat treatment process disclosed in accordance with commonly-assigned U.S. Pat. No. 5,100,484, the contents of which relating to processing of the N5 alloy are incorporated herein by reference. The casting molds were about 400 millimeters in length and about 150 mm in width, and filled to contain about 15 kg of molten alloy. The variables in the experiment were based solely on the chemistry factors and not the process factors described for the Freckle Susceptibility Index, R_e . Casting parameters including furnace temperature, withdrawal rate, and thermal gradient in the castings during cooling were kept as constants throughout the experiment. Therefore, results of the experiment reflected only chemistry affects, and process parameters were not of significance when comparing the results obtained with Alloys A and B to the results obtained with the Baseline Alloy.

[0028] Following casting, the single-crystal buckets were examined by visual and fluorescent penetrant inspection for internal and external freckles. FIGS. 3 and 4 are scanned images showing external freckle chains in buckets formed of the Baseline Alloy and Alloy B, respectively. In FIG. 3, more than twenty freckle chains can be seen on the bucket root of the Baseline Alloy casting. In contrast, only two short freckle chains can be seen at the upper left corner of the bucket root of the Alloy B casting in FIG. 4. FIG. 5 is a graph plotting freckle length measurement data obtained from the buckets cast from all three alloys. The data evidence a reduction in total freckle chain length of about 30% with Alloy A as compared to the Baseline Alloy, and by a factor of about ten for the Alloy B castings. Because Alloys A and B were substantially identical to each other except for their levels of hafnium (0.20% versus 0.50%), it was concluded that hafnium was the single greatest chemistry factor in reducing freckling, and that superior results could be obtained with hafnium levels in excess of about 0.20%, more preferably at least 0.30%.

[0029] The significant reduction in freckling observed in the Alloy A castings evidenced the influence that small changes in aluminum, tantalum, tungsten, rhenium, and zirconium levels can also have on freckling. In particular, the experimental results indicated that N5 castings with aluminum levels of less than 6.20%, tantalum levels of more than 6.44%, tungsten levels of less than 4.90%, rhenium levels of less than 2.91%, and zirconium levels of less than 0.007% can exhibit significantly improved resistance to freckling over an N5 castings identical in every other aspect. Furthermore, it was evident that the resistance to freckling is extremely sensitive to the levels of these elements.

[0030] Finally, the results from the casting experiments were believed to confirm the predictions made with equation for the Freckle Susceptibility Index, R_e .

[0031] While the invention has been described in terms of specific embodiments, it is apparent that other forms could be

adopted by one skilled in the art. For example, the physical configuration of the castings could differ from that shown, and processes other than those noted could be used to produce the castings. Therefore, the scope of the invention is to be limited only by the following claims.

1. A nickel-base superalloy having a composition consisting of, by weight:

6% to 8% chromium;
6% to 9% cobalt;
0% to 2% molybdenum;
4% to 6% tungsten;
6.4% to 6.9% tantalum;
0% to 2% titanium;
5% to 7% aluminum;
2.7% to 3.0% rhenium;
0.3% to 0.7% hafnium;
0.04% to 0.08% carbon;
0.002% to 0.006% boron;
0% to 0.075% yttrium;
0.002% to 0.004% zirconium;

the balance being nickel and incidental impurities.

2. The nickel-base superalloy according to claim 1, wherein the nickel-base superalloy is in the form of a casting.

3. The nickel-base superalloy according to claim 2, wherein the casting is substantially free of freckle defects.

4. The nickel-base superalloy according to claim 2, wherein the casting has a unidirectional crystal structure.

5. The nickel-base superalloy according to claim 4, wherein the unidirectional crystal structure is a single crystal.

6. The nickel-base superalloy according to claim 4, wherein the casting is a component for a gas turbine.

7. The nickel-base superalloy according to claim 1, wherein the composition contains 6.5 to 6.8 weight percent tantalum.

8. The nickel-base superalloy according to claim 1, wherein the composition contains about 6.7 weight percent tantalum.

9. The nickel-base superalloy according to claim 1, wherein the composition contains 6.0 to 6.2 weight percent aluminum.

10. The nickel-base superalloy according to claim 1, wherein the composition contains about 6.1 weight percent aluminum.

11. The nickel-base superalloy according to claim 1, wherein the composition contains 2.75 to 2.9 weight percent rhenium.

12. The nickel-base superalloy according to claim 1, wherein the composition contains about 2.8 weight percent rhenium.

13. The nickel-base superalloy according to claim 1, wherein the composition contains 0.4 to 0.6 weight percent hafnium.

14. The nickel-base superalloy according to claim 1, wherein the composition contains about 0.5 weight percent hafnium.

15. The nickel-base superalloy according to claim 1, wherein the composition contains 0.002 to 0.003 weight percent zirconium.

16. The nickel-base superalloy according to claim 1, wherein the composition contains about 0.0025 weight percent zirconium.

17. The nickel-base superalloy according to claim 1, wherein the composition contains, by weight, less than 4.90% tungsten, more than 6.44% tantalum, less than 6.20% aluminum, and less than 2.91% rhenium.

18. (canceled)

19. A nickel-base superalloy in the form of a casting having a unidirectional crystal structure that is substantially free of freckle defects, the superalloy having a composition consisting of, by weight:

6.75% to 7.25% chromium;
7% to 8% cobalt;
1.3% to 1.7% molybdenum;
4.5% to 5.0% tungsten;
6.5% to 6.8% tantalum;
0% to 0.05% titanium;
6.0% to 6.2% aluminum;
2.75% to 2.90 rhenium;
0.4% to 0.6% hafnium;
0.04% to 0.08% carbon;
0.003% to 0.005% boron;
0% to 0.075% yttrium;
0.002% to 0.003% zirconium;

the balance being nickel and incidental impurities.

20. The nickel-base superalloy according to claim 19, wherein the composition consists of, by weight:

about 7% chromium;
about 7.5% cobalt;
about 1.5% molybdenum;
about 4.75% tungsten;
about 6.7% tantalum;
about 0% to 0.02% titanium;
about 6.1 % aluminum;
about 2.8% rhenium;
about 0.5% hafnium;
about 0.06% carbon;
about 0.004% boron;
0% to 0.03% yttrium;
about 0.0025% zirconium;

the balance being nickel and incidental impurities.

* * * * *