

US 20100032004A1

(19) **United States**

(12) **Patent Application Publication**
Baker et al.

(10) **Pub. No.: US 2010/0032004 A1**

(43) **Pub. Date: Feb. 11, 2010**

(54) **SOLAR SYSTEMS THAT INCLUDE ONE OR MORE SHADE-TOLERANT WIRING SCHEMES**

(76) Inventors: **James T. Baker**, Temple City, CA (US); **Charles R. Haythornthwaite**, Vancouver (CA); **Braden E. Hines**, Pasadena, CA (US); **Richard L. Johnson, JR.**, Suffolk, VA (US); **Michael F. Turk**, Los Angeles, CA (US)

Correspondence Address:
KAGAN BINDER, PLLC
SUITE 200, MAPLE ISLAND BUILDING, 221 MAIN STREET NORTH
STILLWATER, MN 55082 (US)

(21) Appl. No.: **12/454,319**

(22) Filed: **May 15, 2009**

Related U.S. Application Data

(60) Provisional application No. 61/128,009, filed on May 16, 2008, provisional application No. 61/131,178, filed on Jun. 6, 2008, provisional application No. 61/209,526, filed on Mar. 6, 2009.

Publication Classification

(51) **Int. Cl.**
H01L 31/052 (2006.01)
H01L 31/042 (2006.01)
H01L 31/18 (2006.01)
(52) **U.S. Cl. 136/246; 136/244; 438/80; 257/E21.499**

(57) **ABSTRACT**

The present invention provides shade tolerant wiring solutions for solar systems. Elements are grouped and wired in parallel within a group such that the total current of a group is substantially the same among multiple groups. Such a wiring scheme can be applied to solar targets (e.g., solar cells), solar , and solar modules.

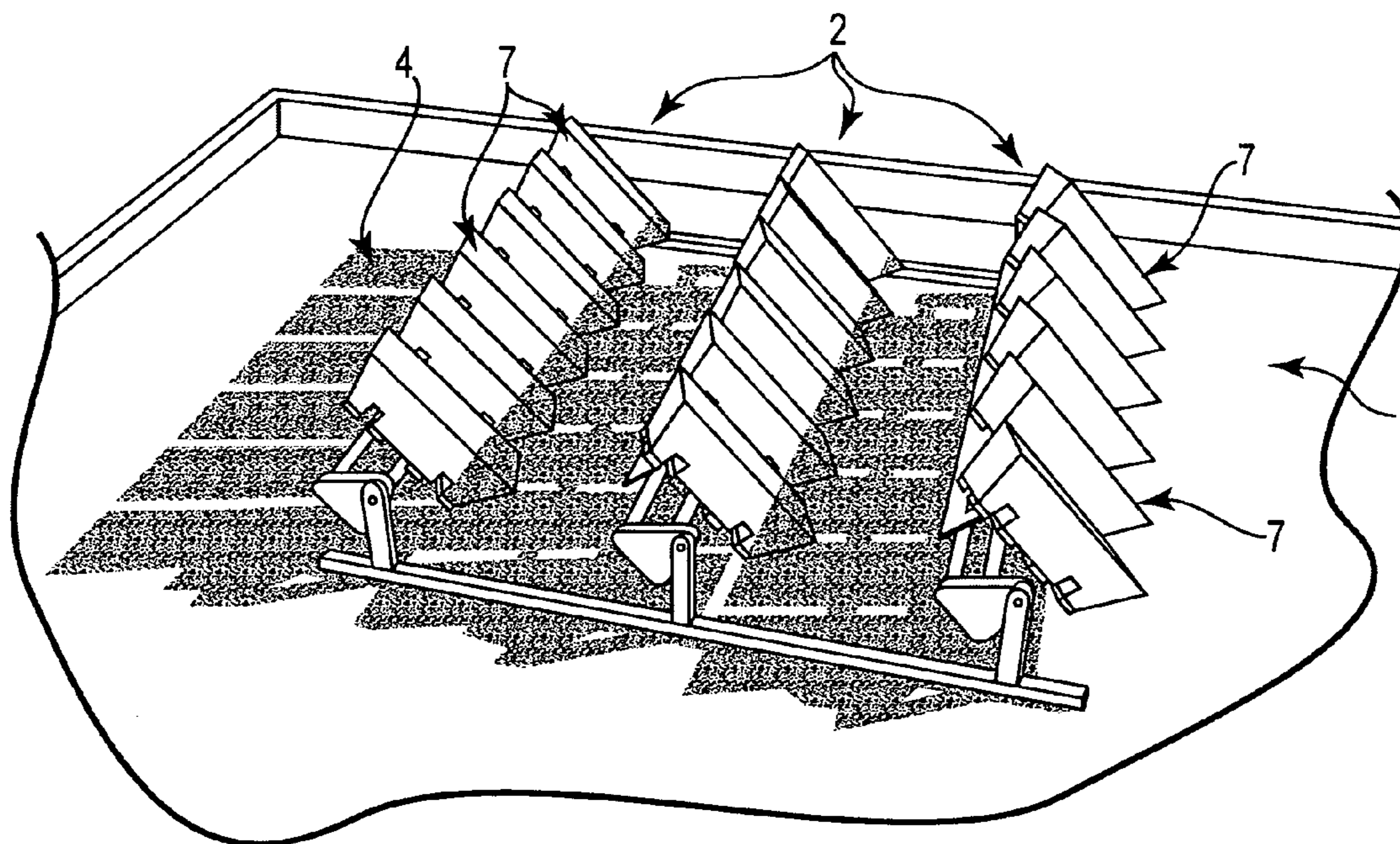

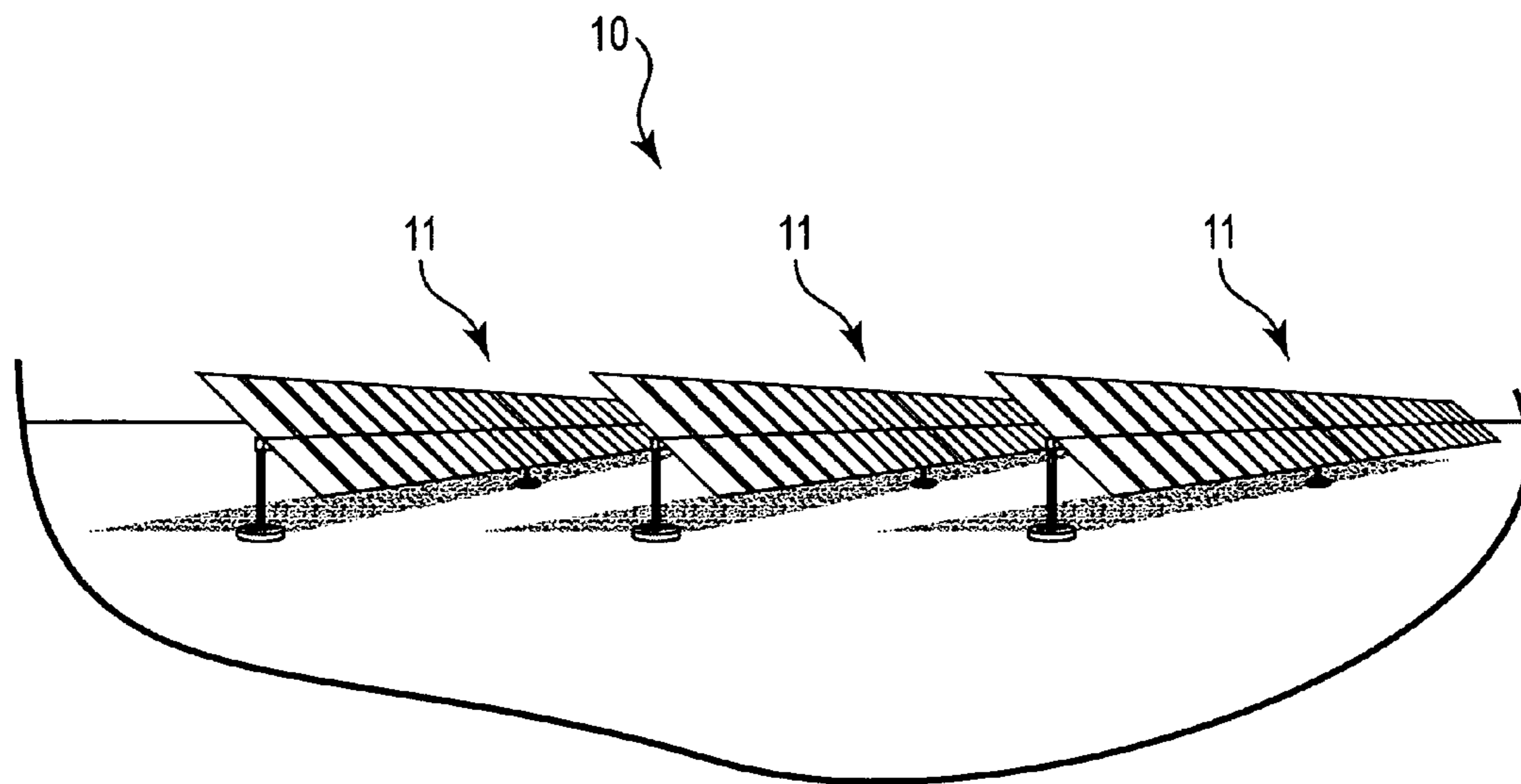

Fig. 1
PRIOR ART

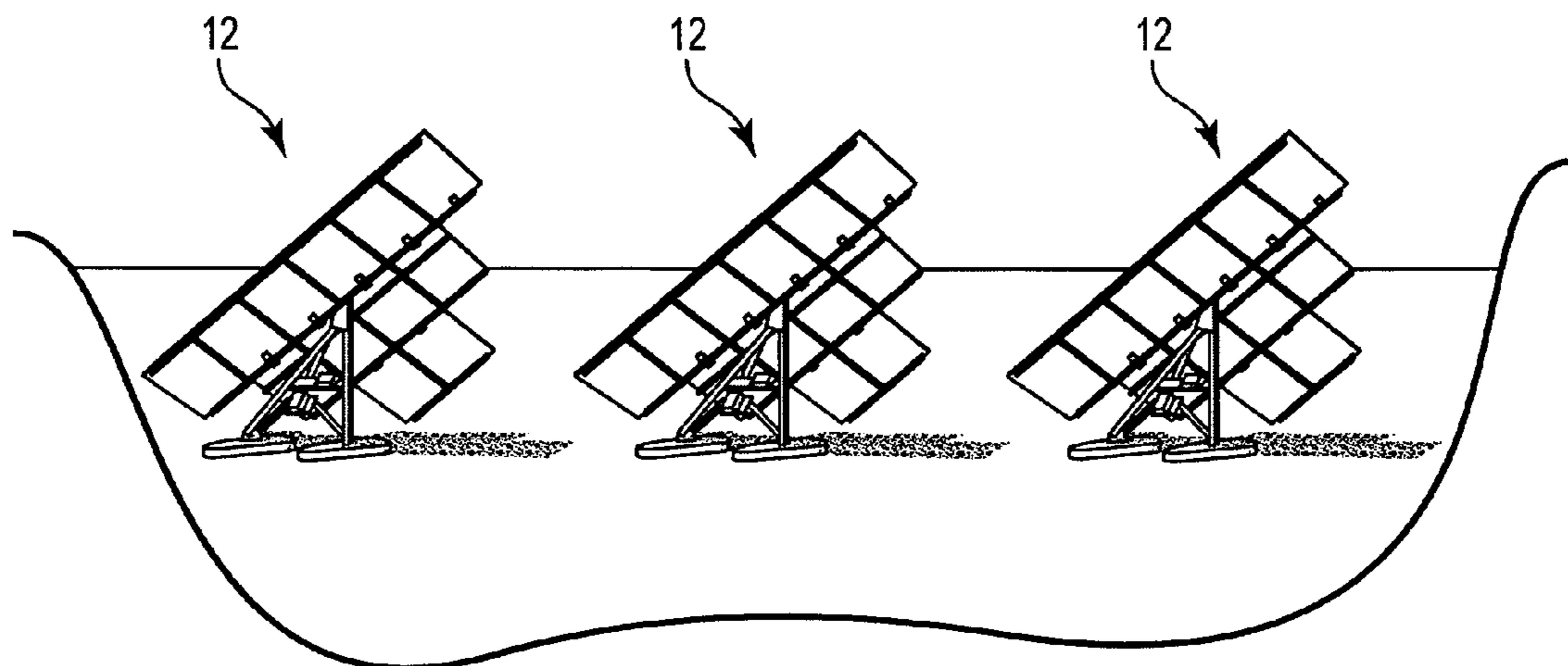

Fig. 2
PRIOR ART

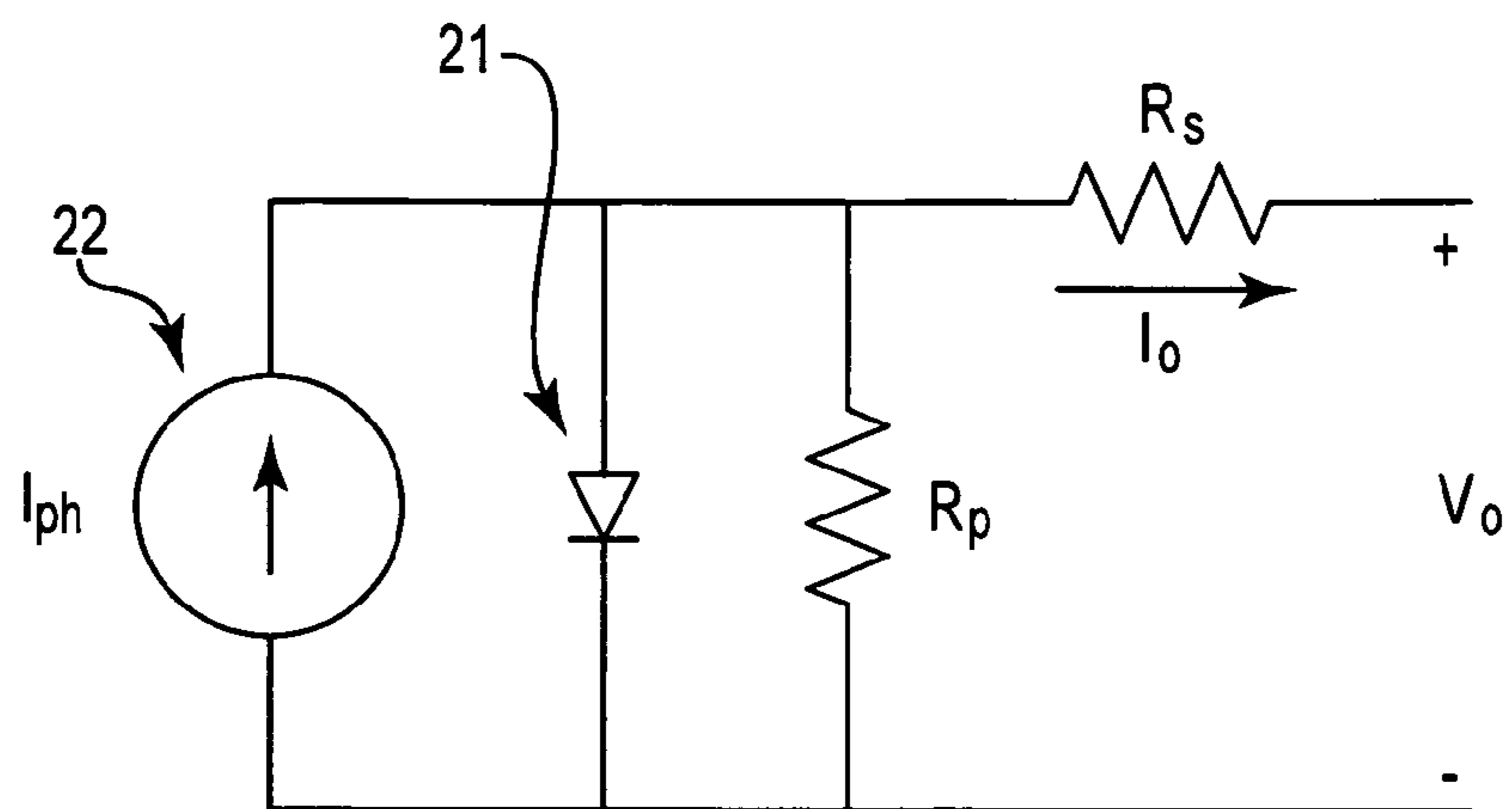

Fig. 3
PRIOR ART

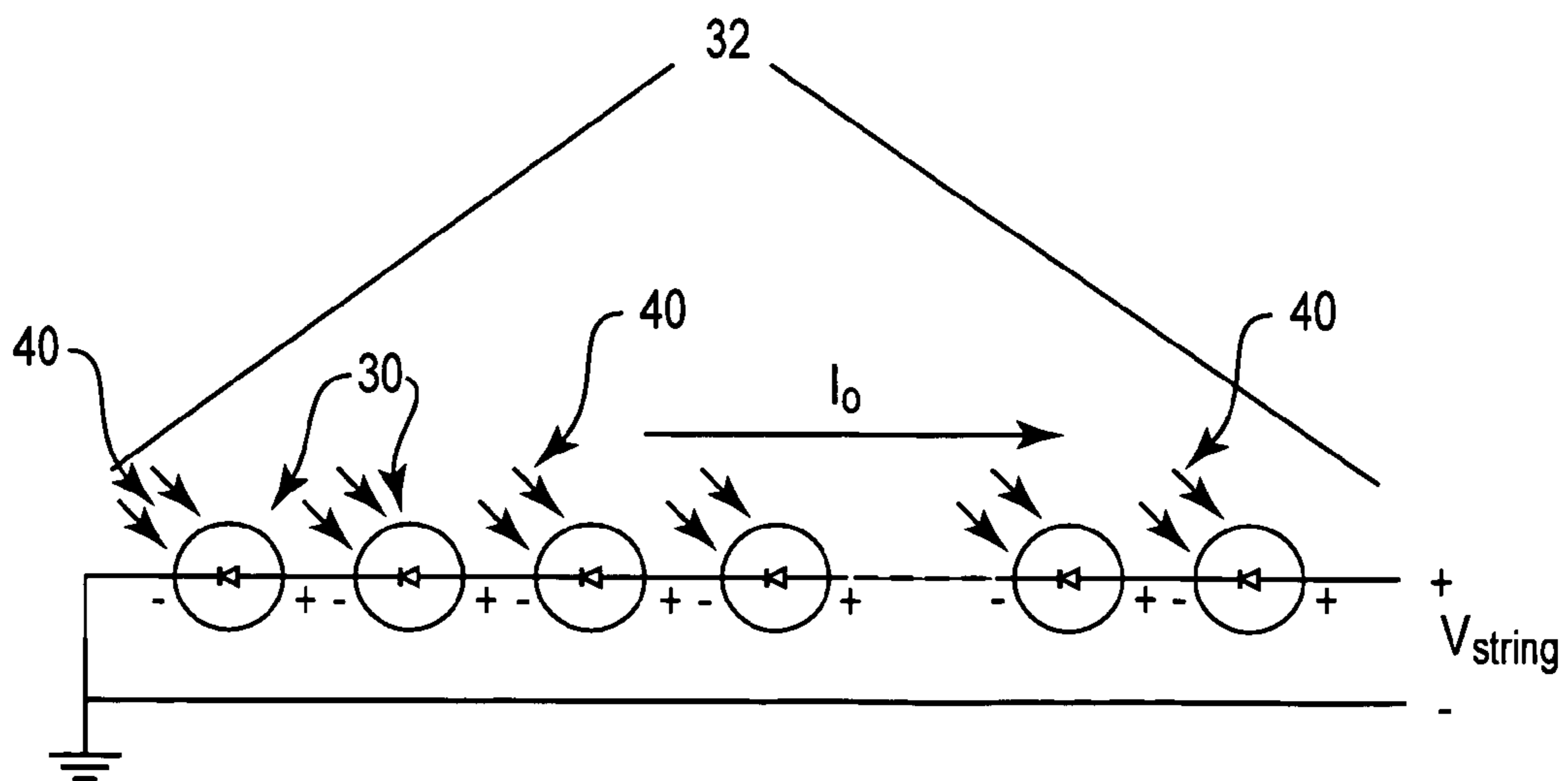

Fig. 4
PRIOR ART

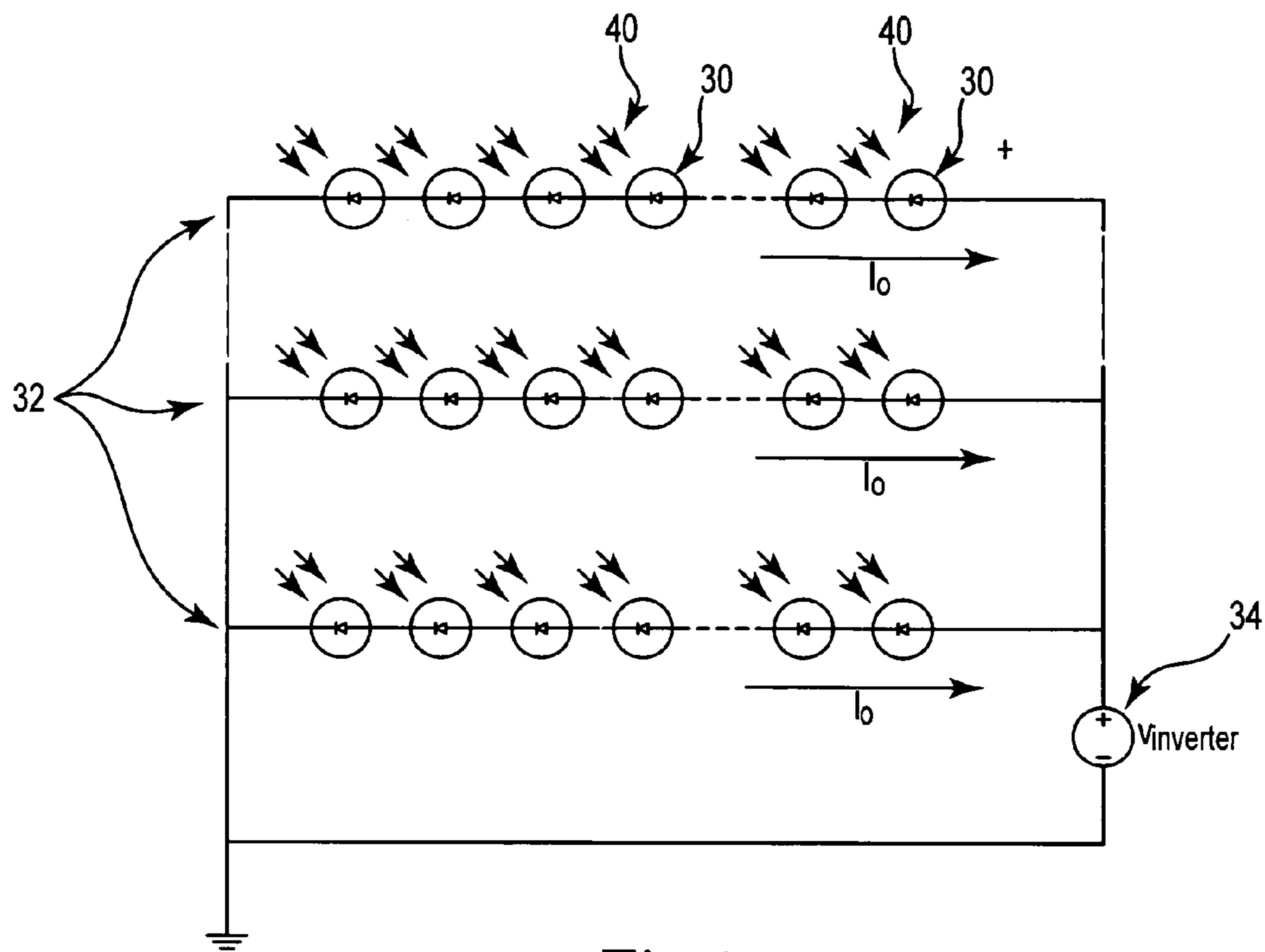

Fig. 5
PRIOR ART

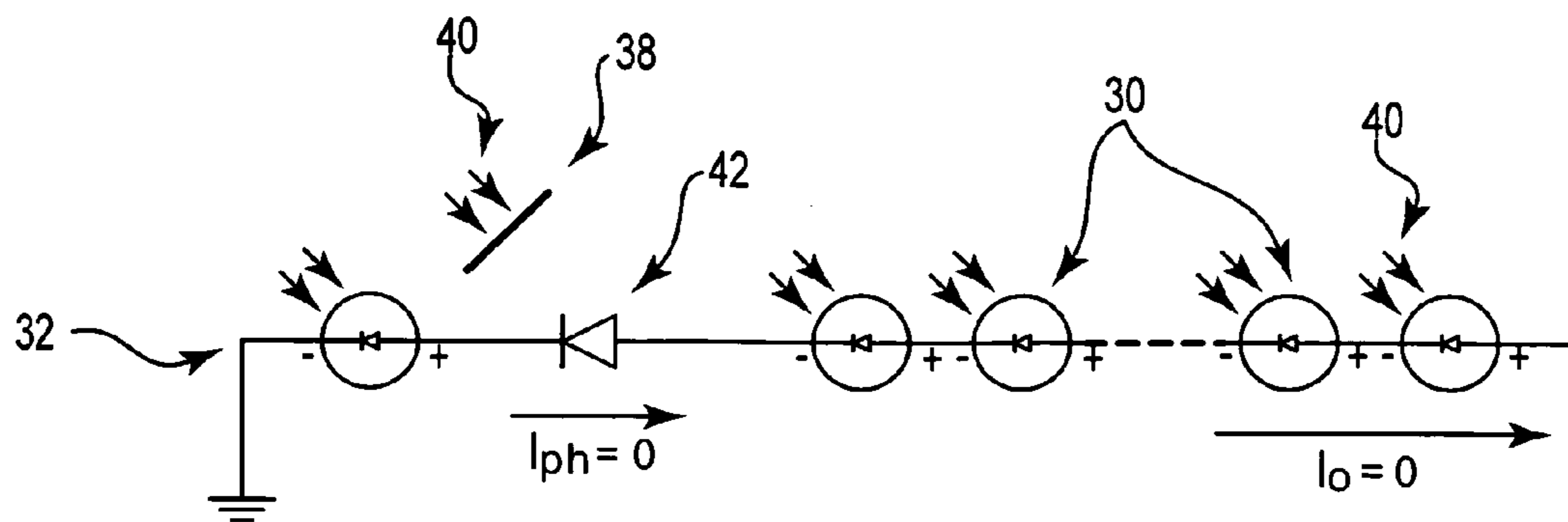

Fig. 6A
PRIOR ART

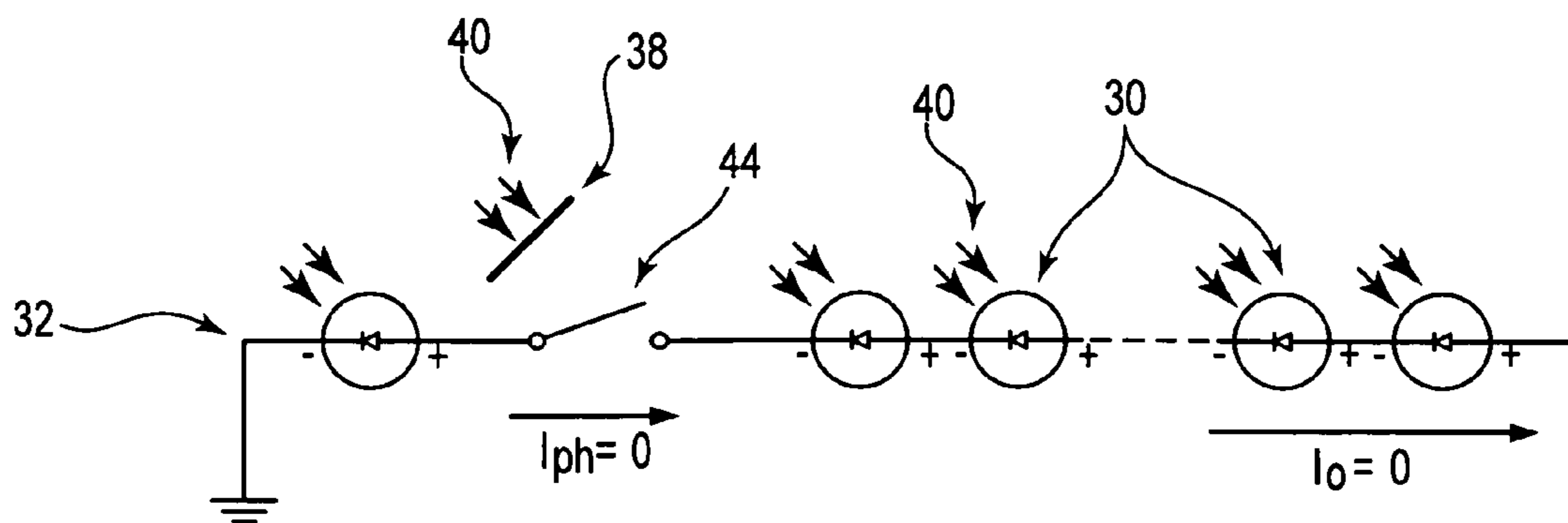

Fig. 6B
PRIOR ART

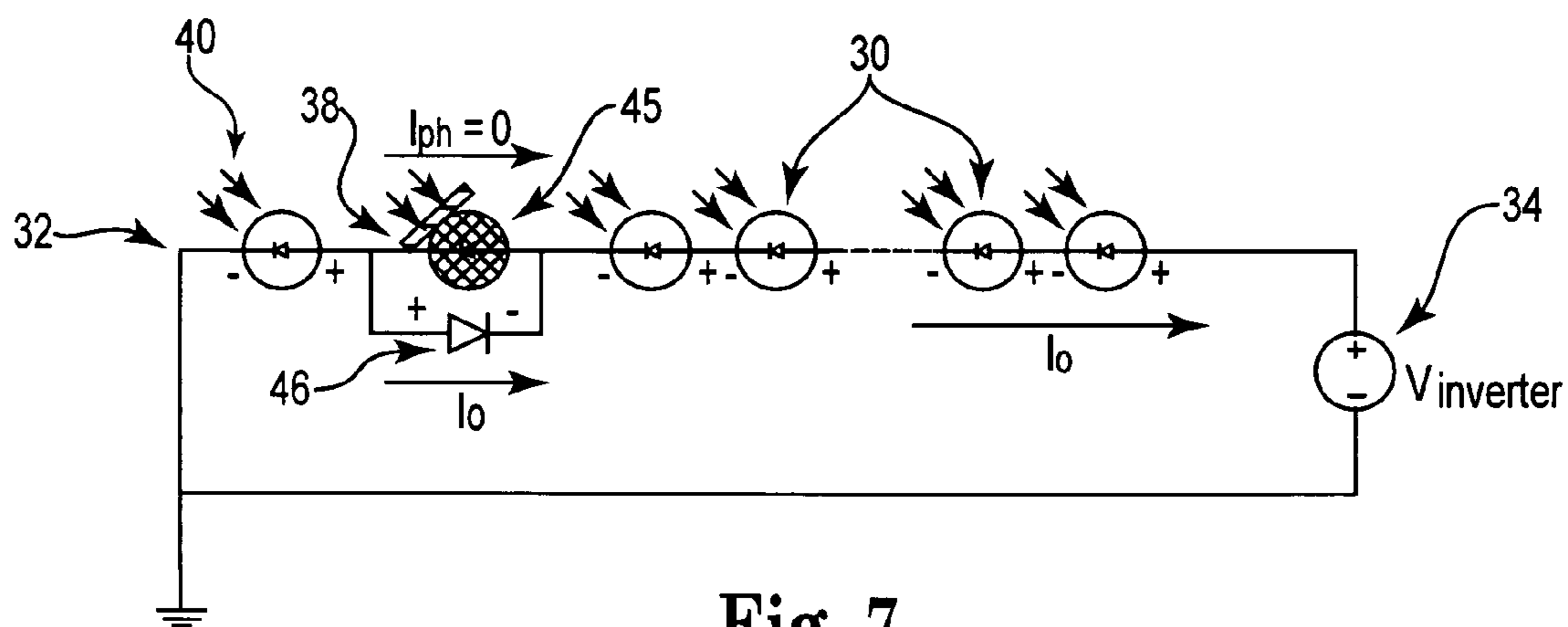

Fig. 7
PRIOR ART

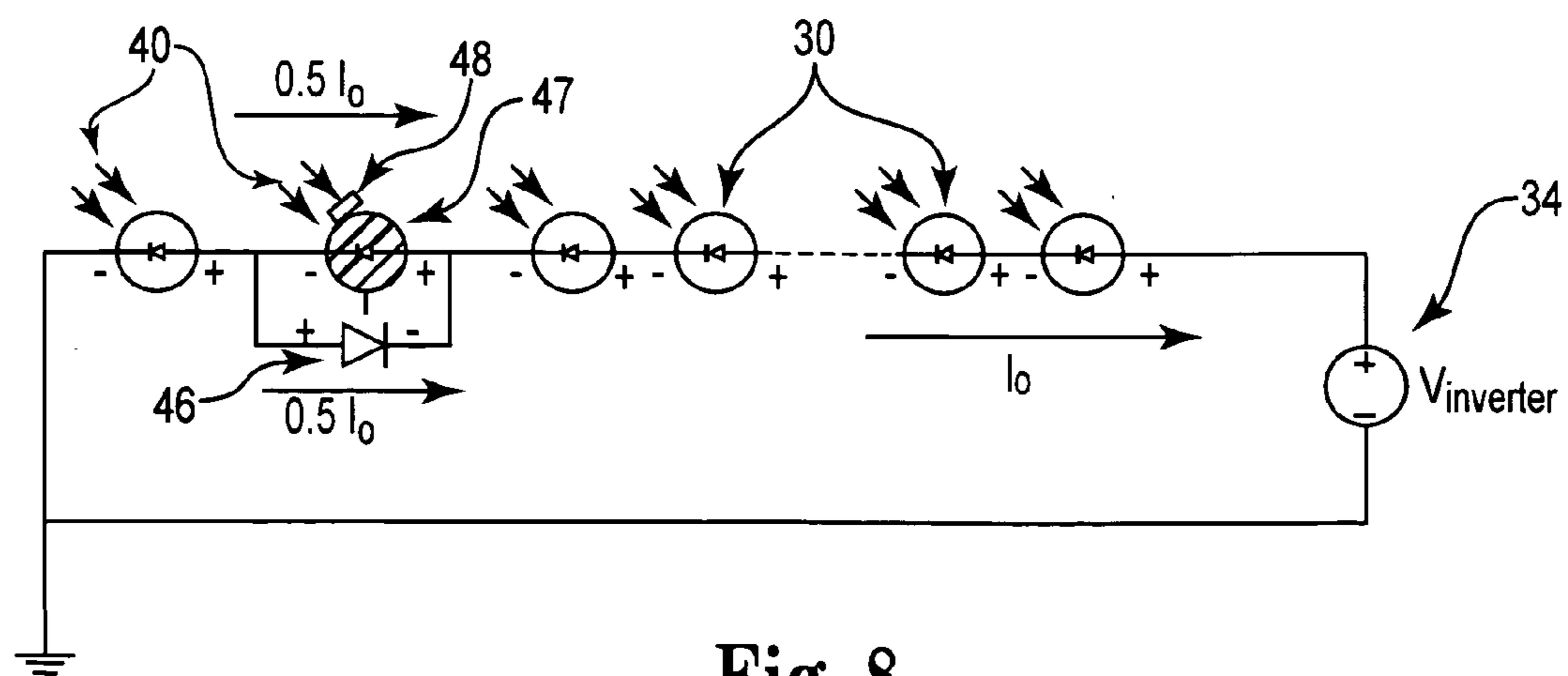

Fig. 8
PRIOR ART

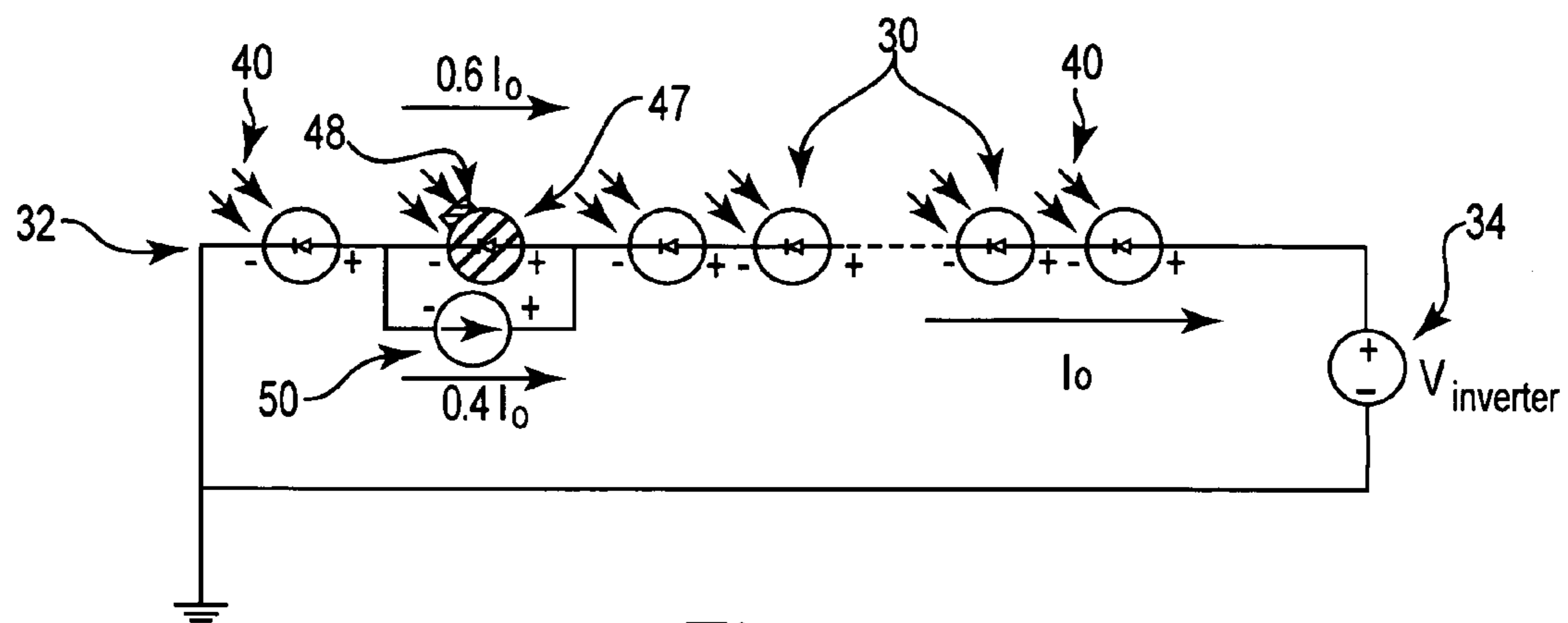

Fig. 9

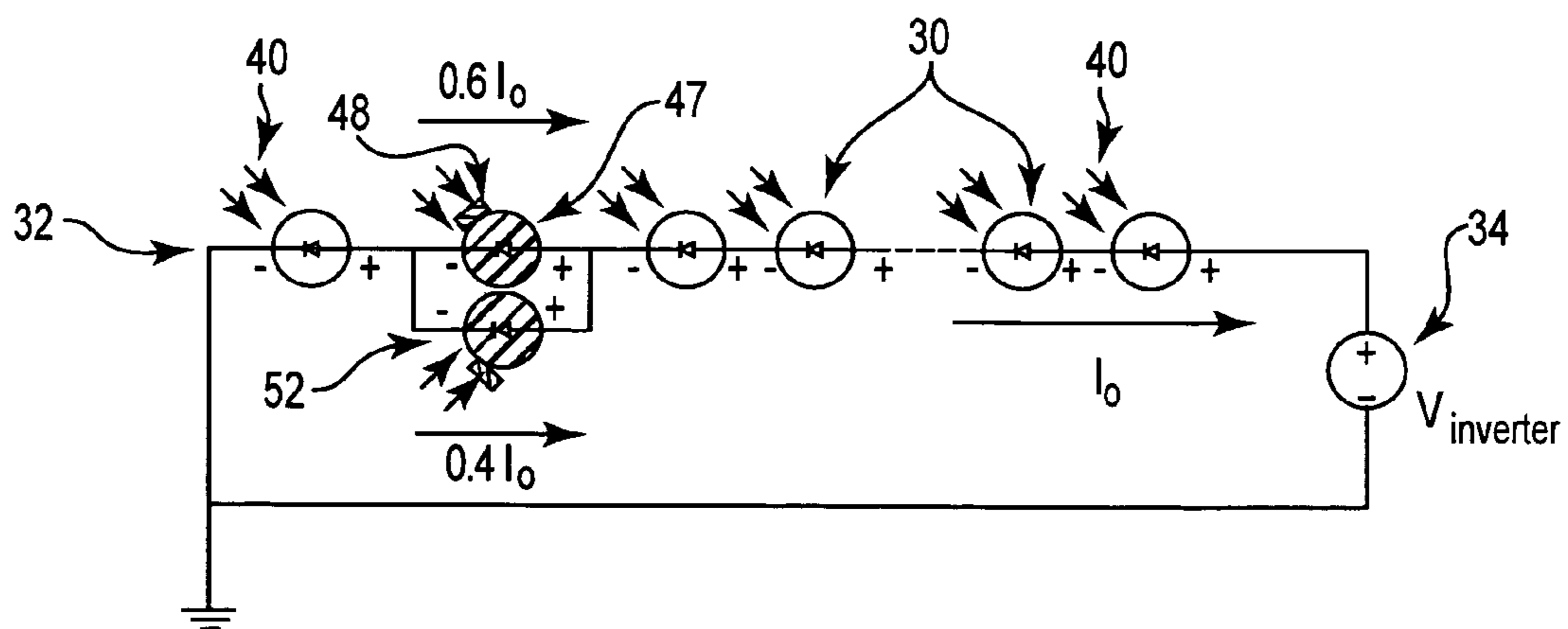

Fig. 10

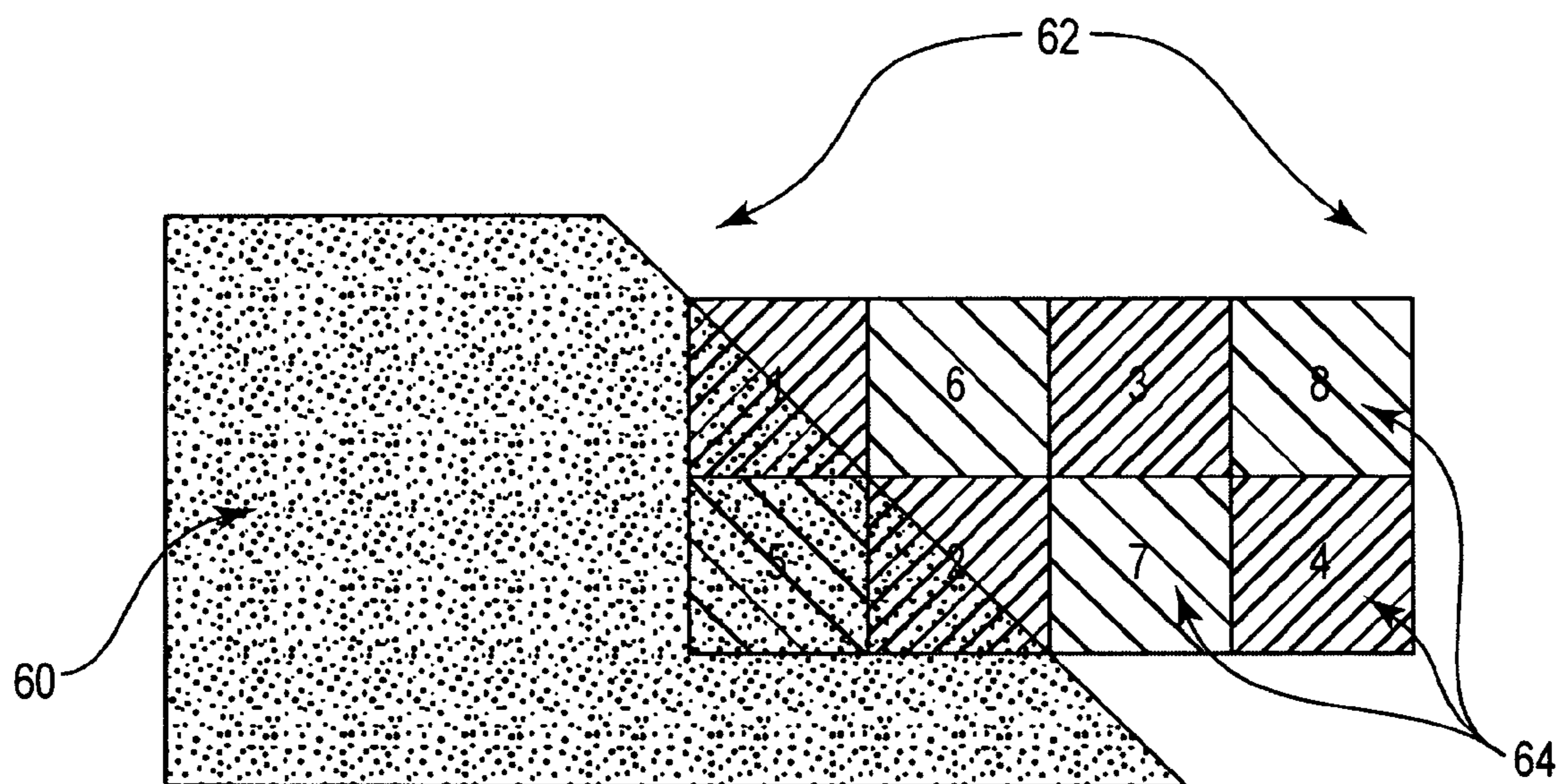

Fig. 11A

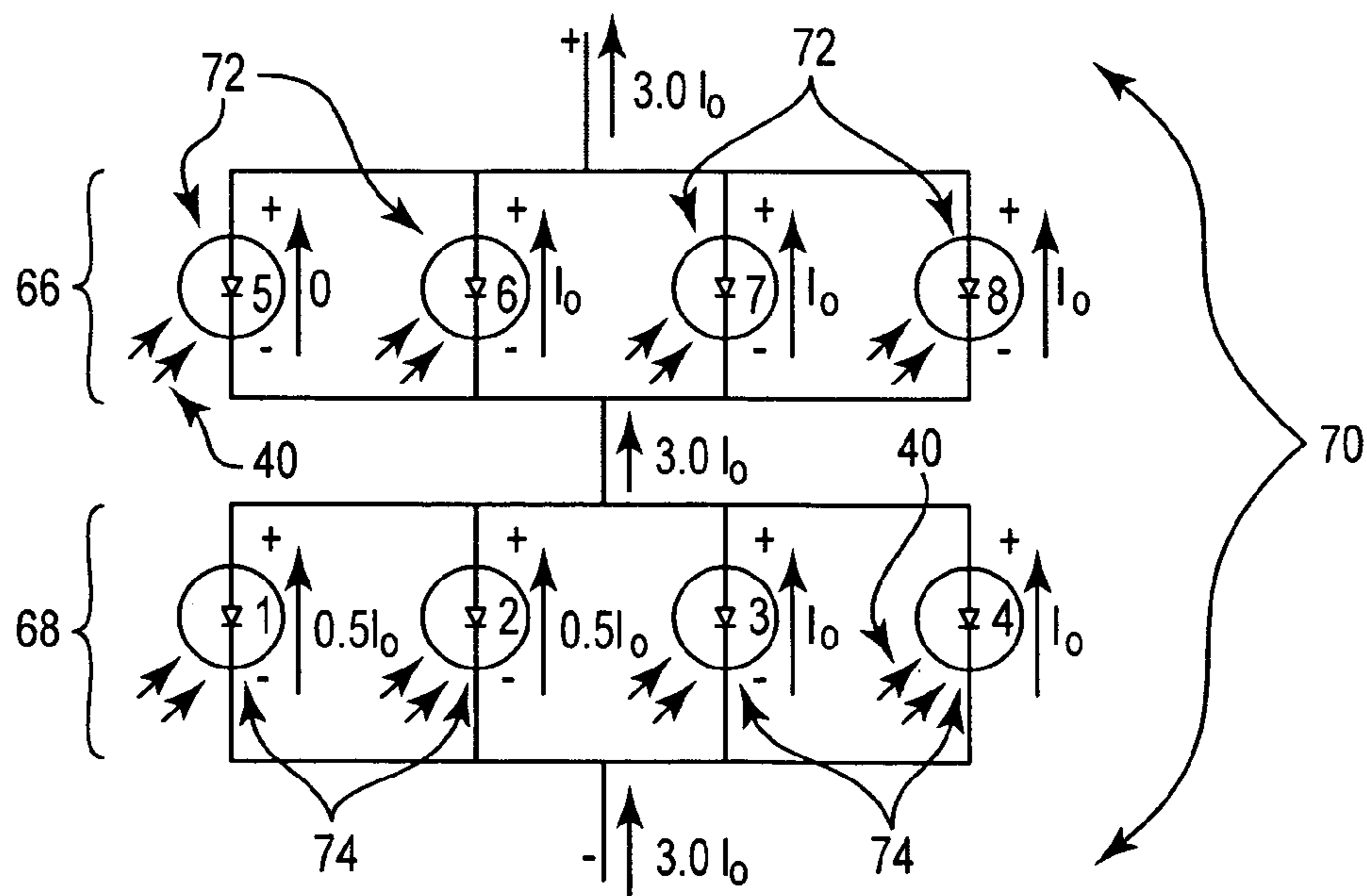

Fig. 11B

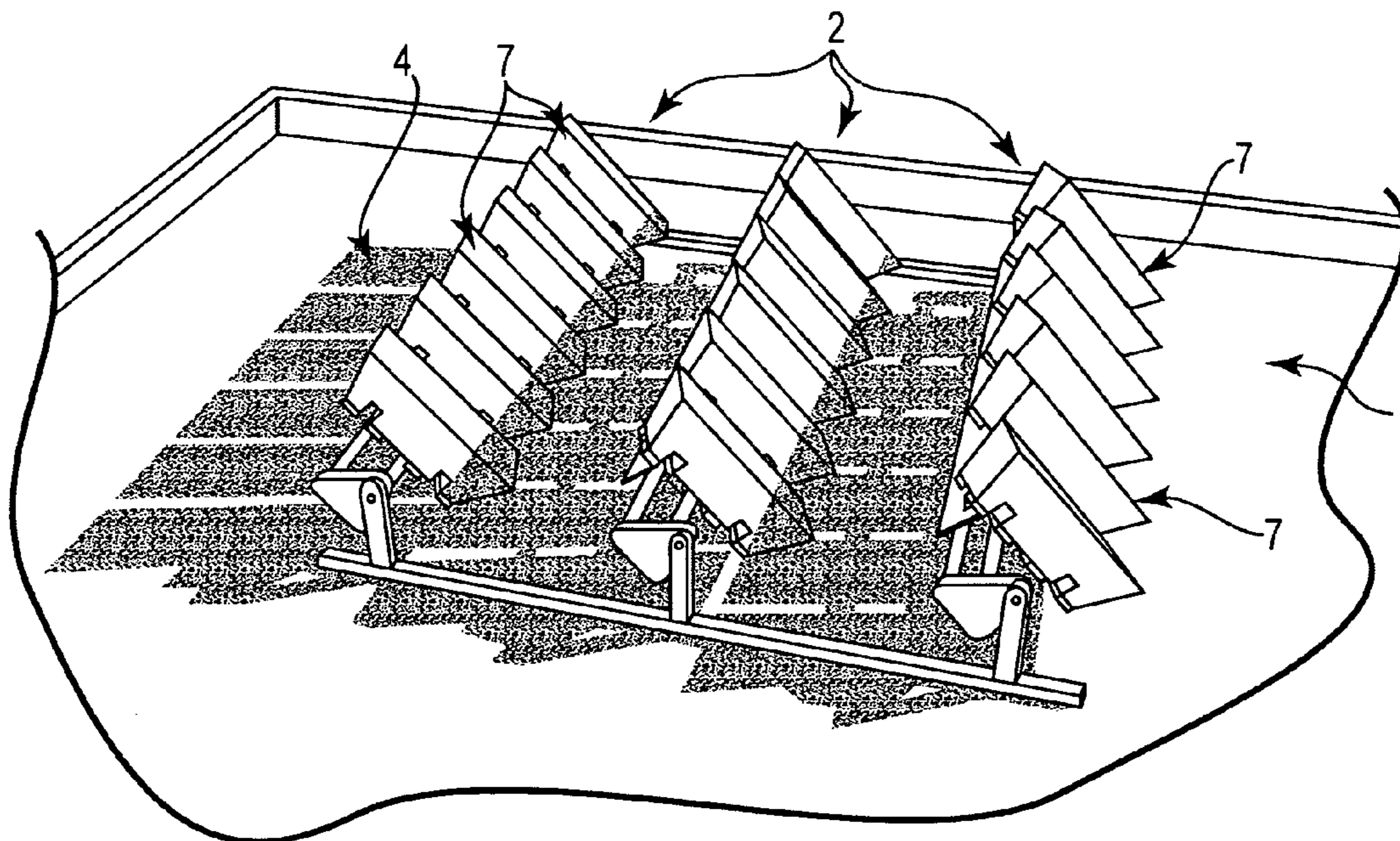

Fig. 12A

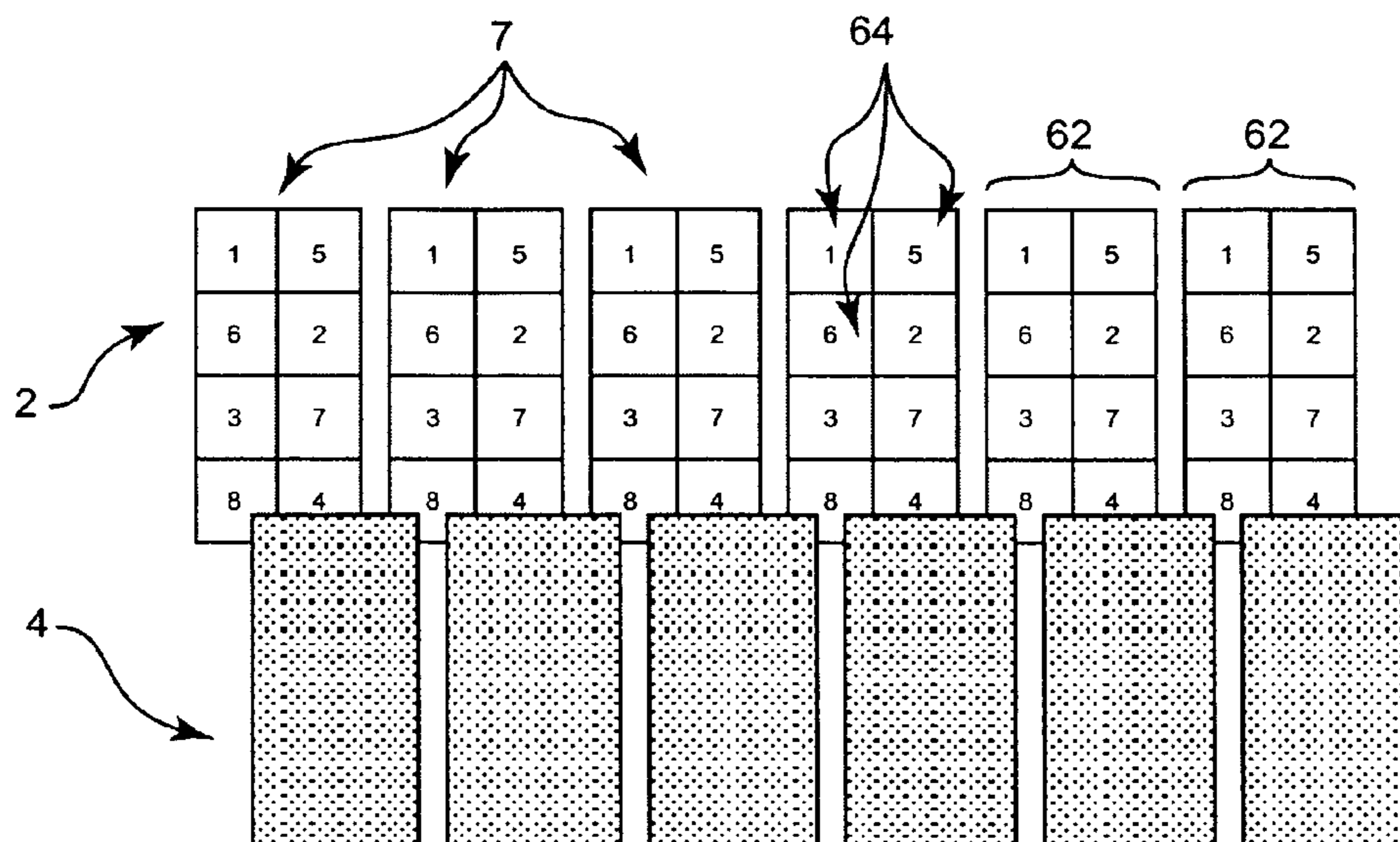

Fig. 12B

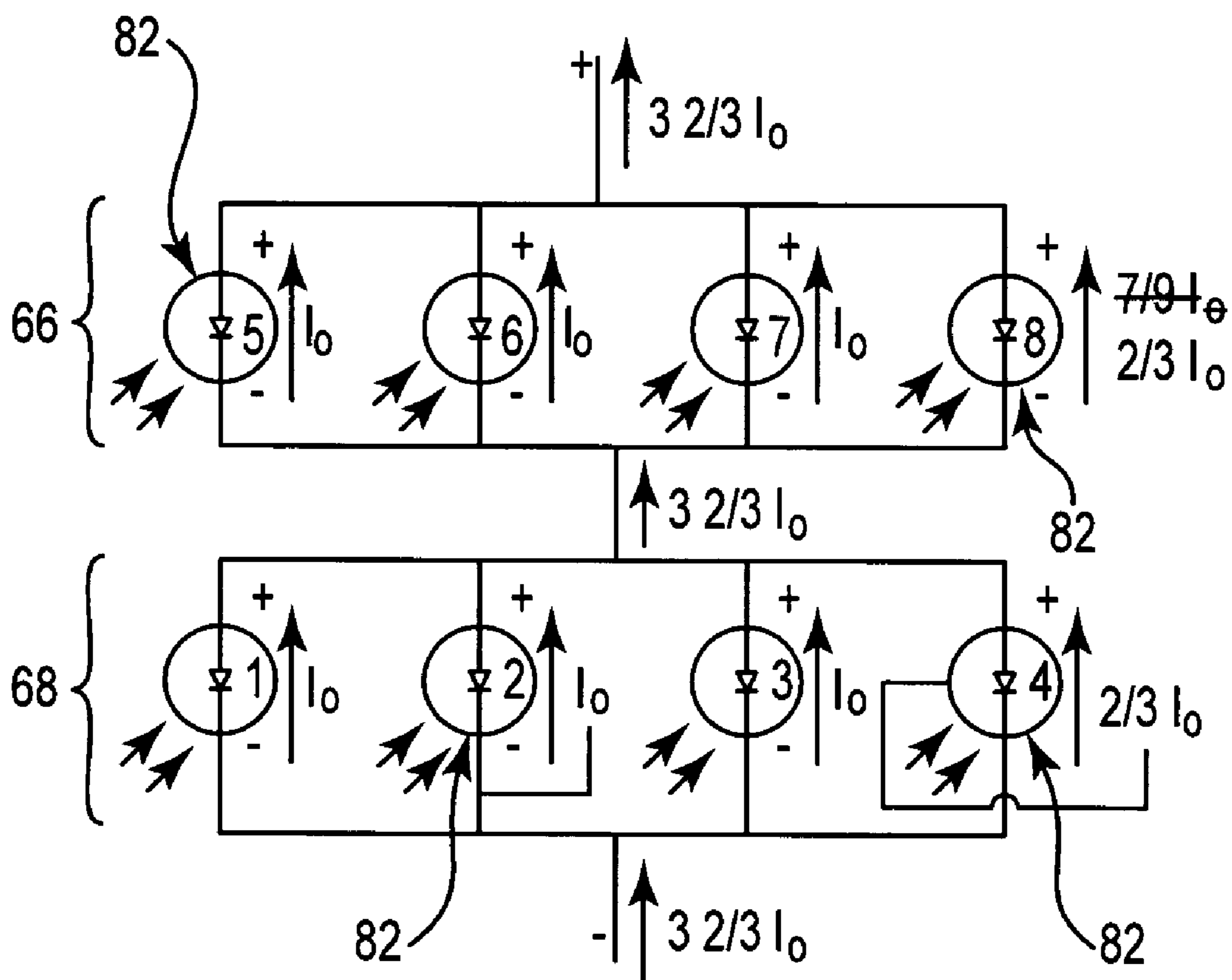

Fig. 13

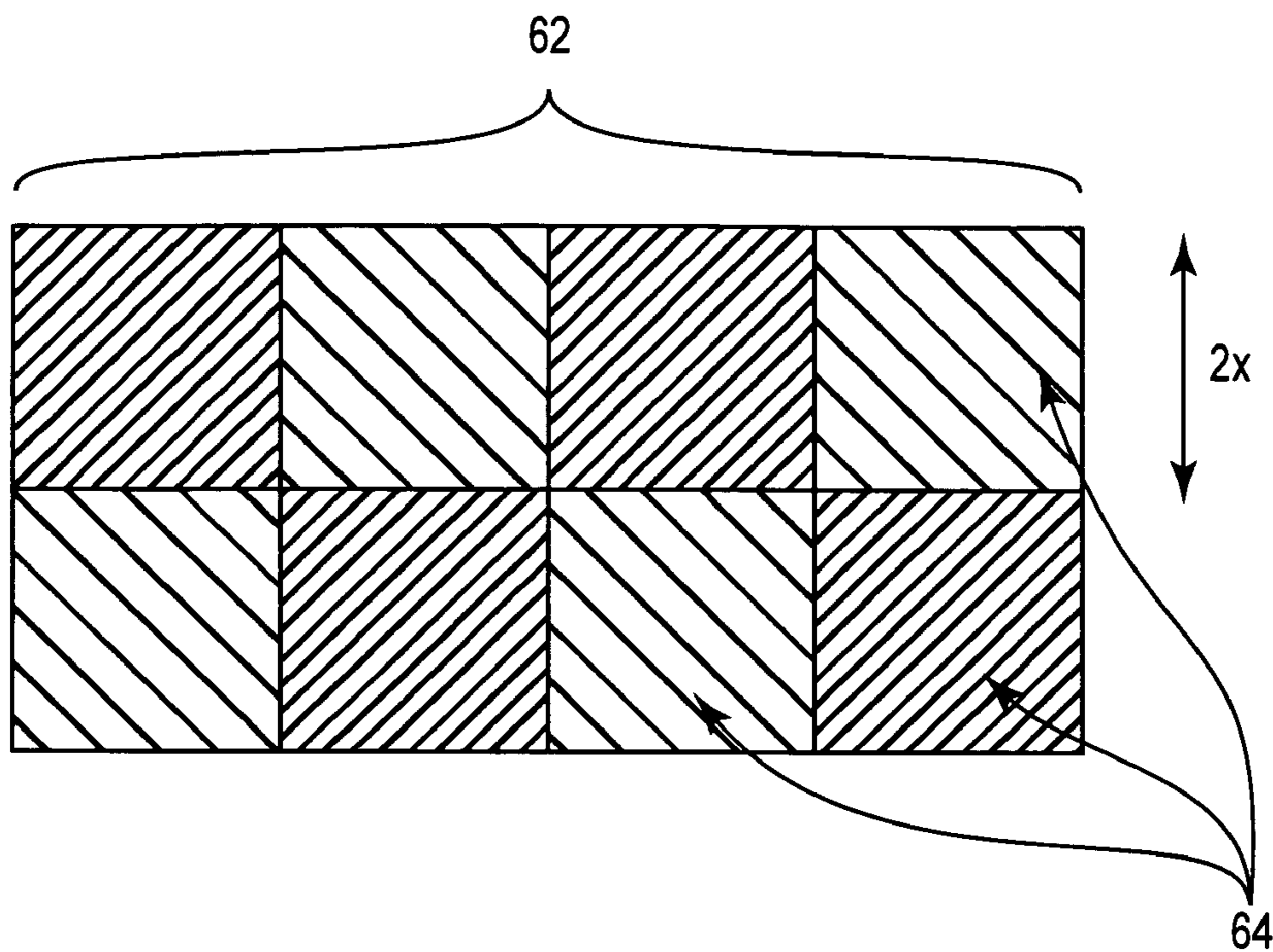

Fig. 14A

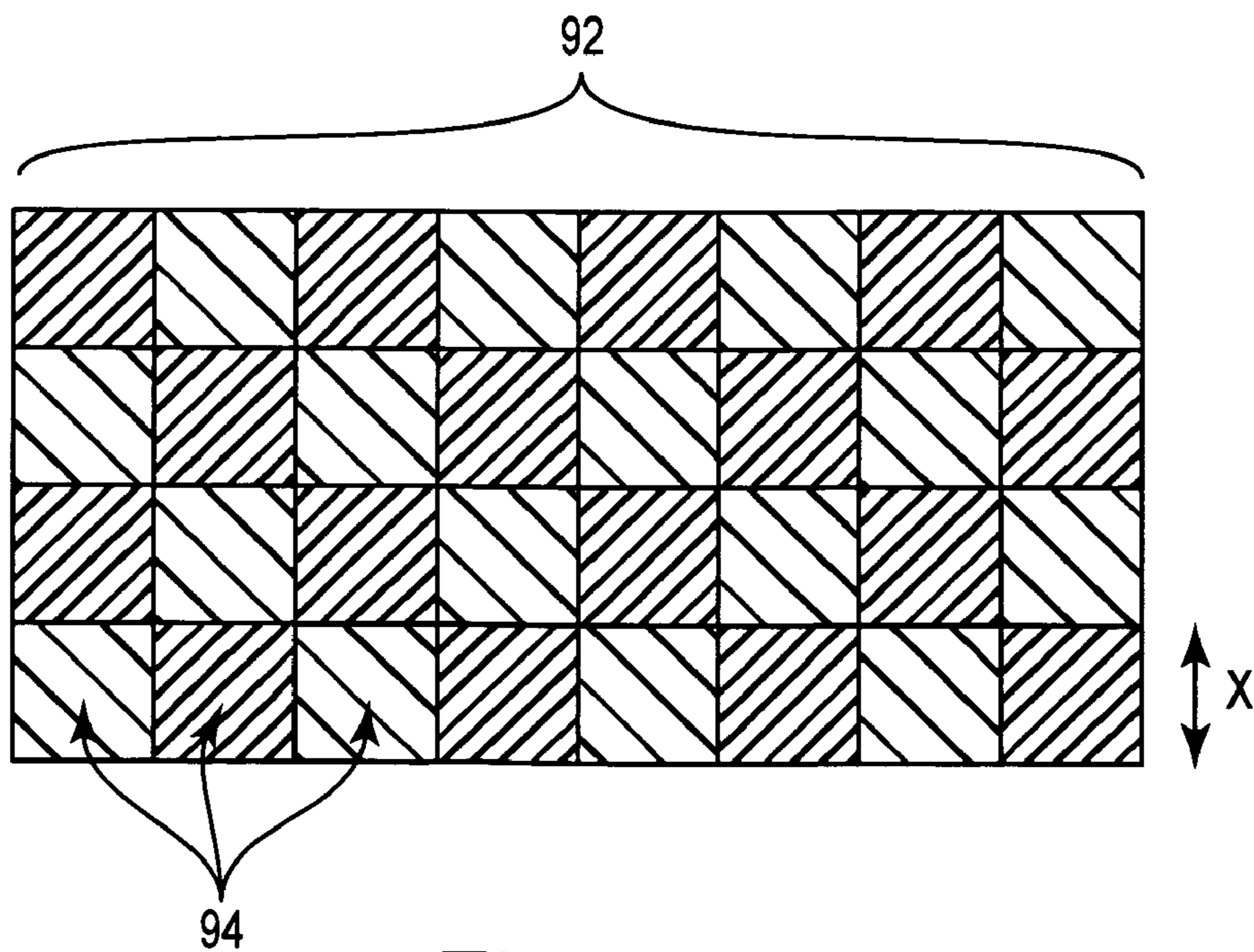

Fig. 14B

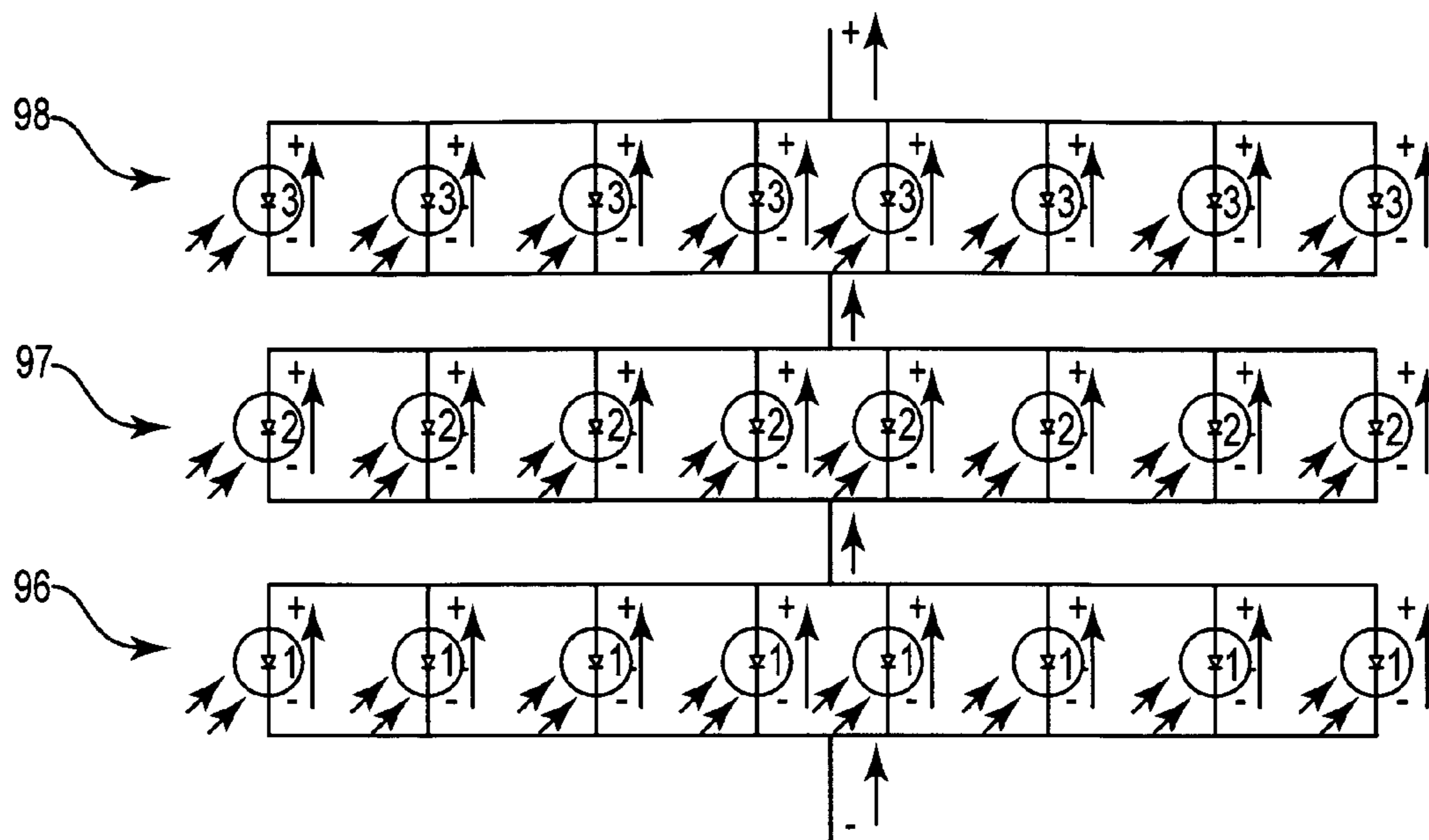

Fig. 15A

2	3	1	2	3	1
1	2	3	1	2	3
3	1	2	3	1	2
2	3	1	2	3	1

Fig. 15B

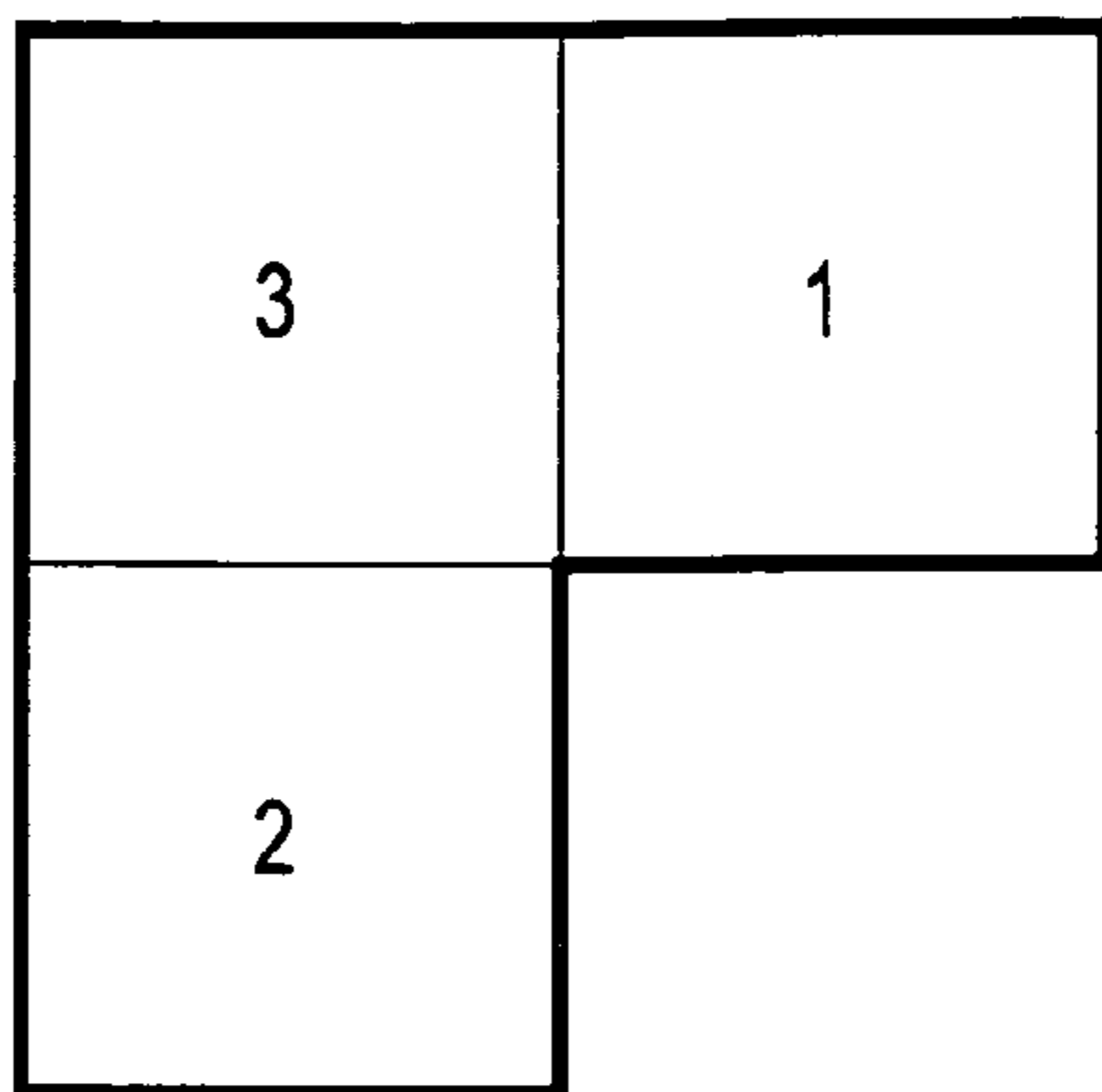

Fig. 15C

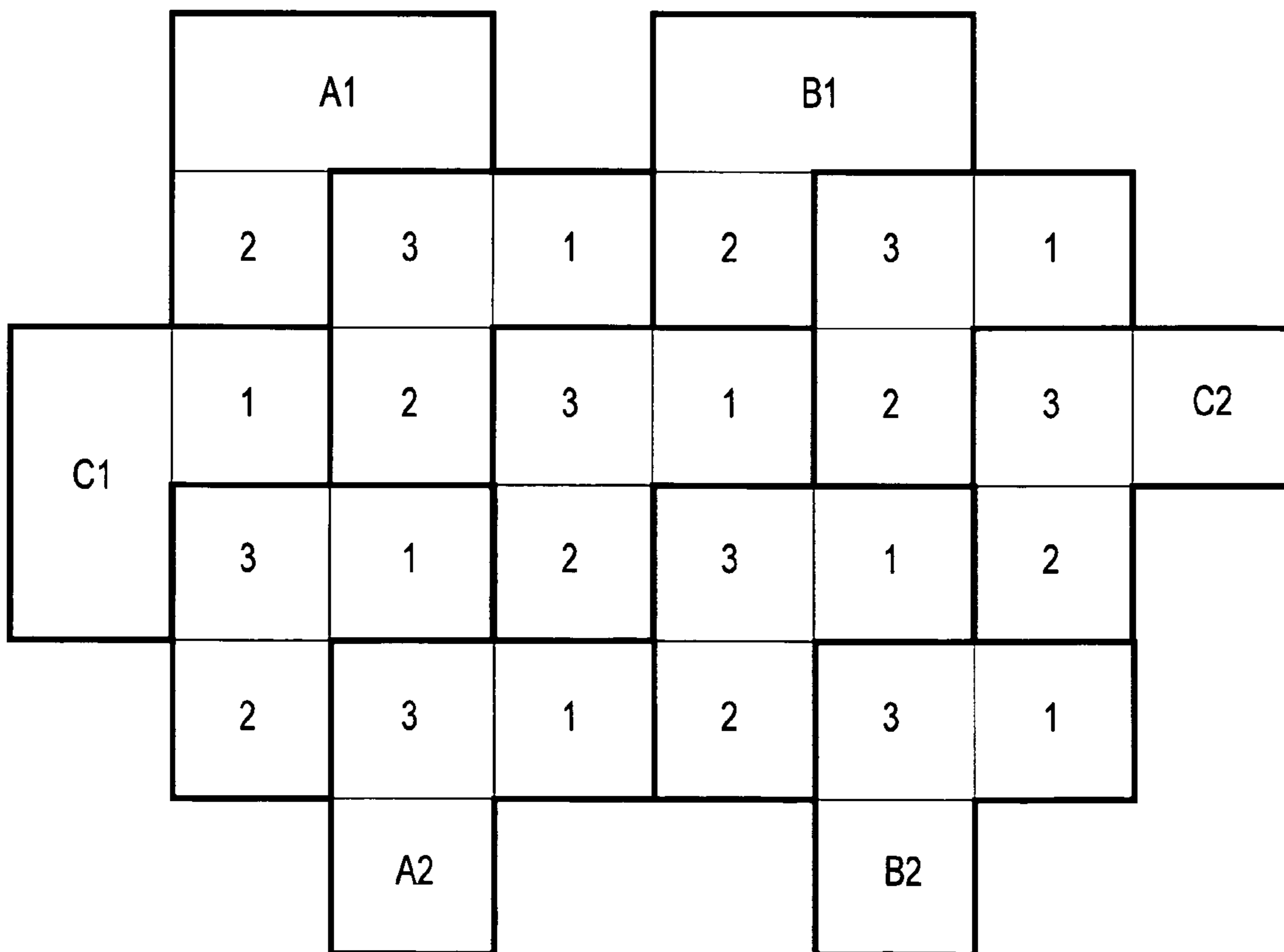

Fig. 15D

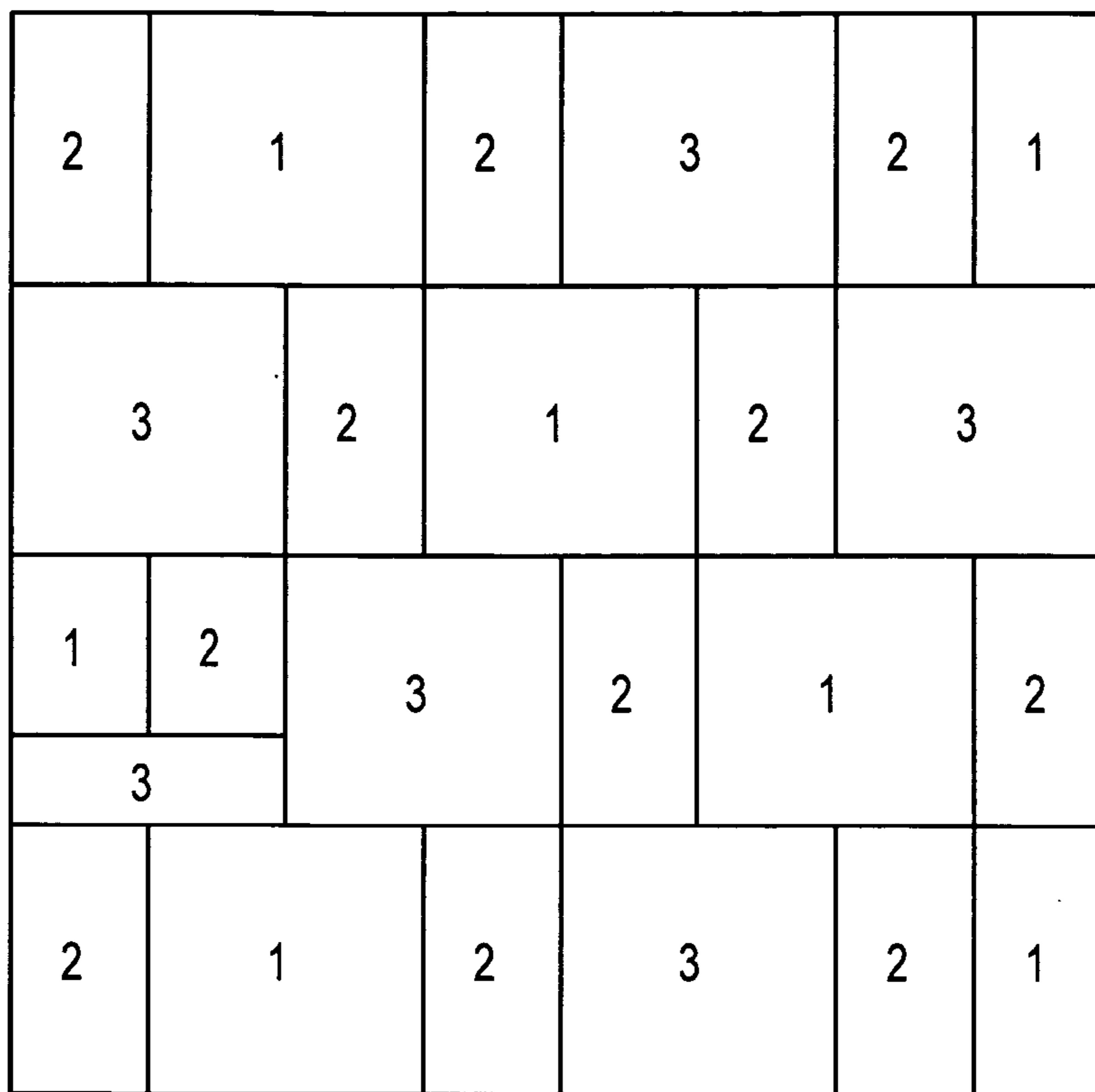

Fig. 16A

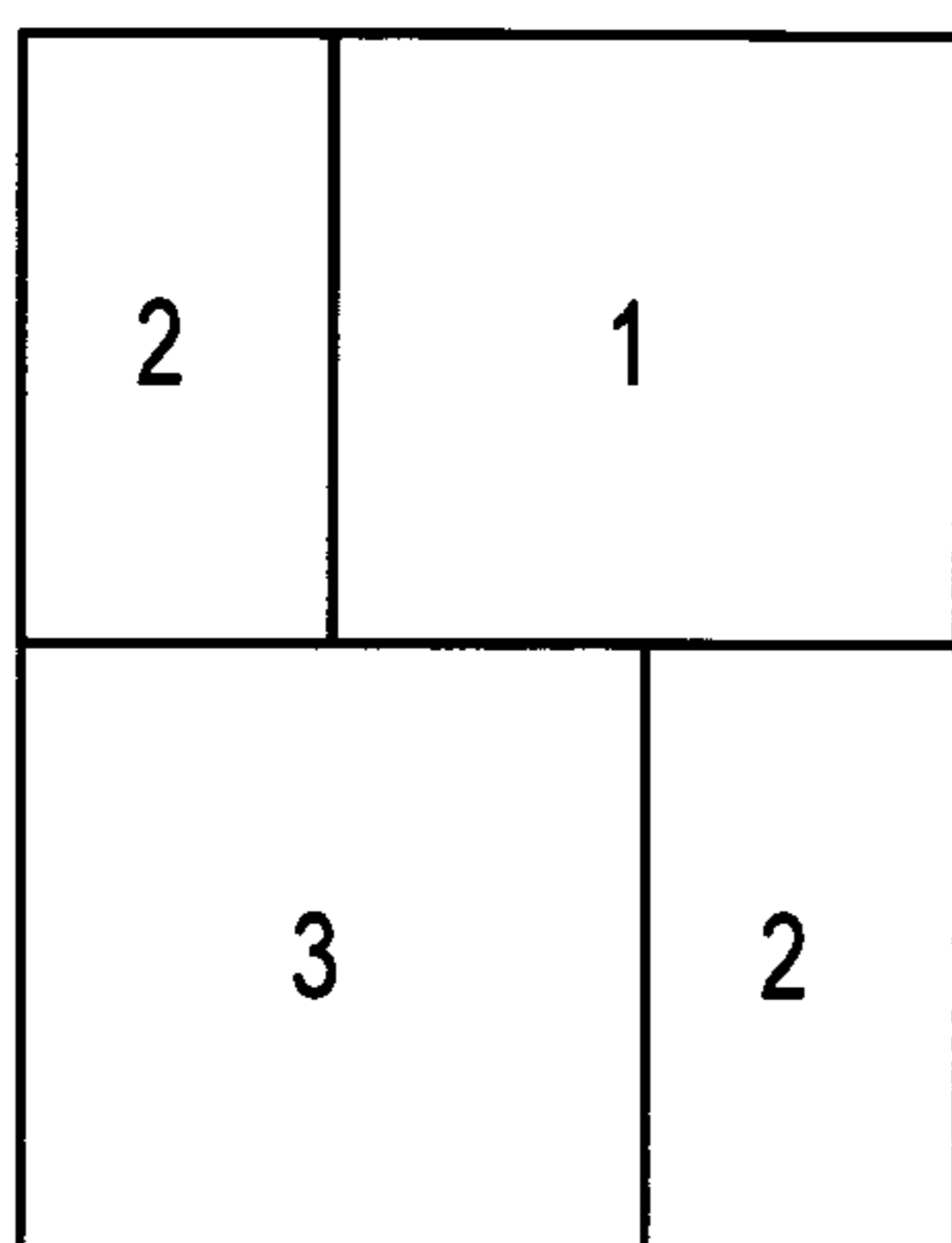

Fig. 16B

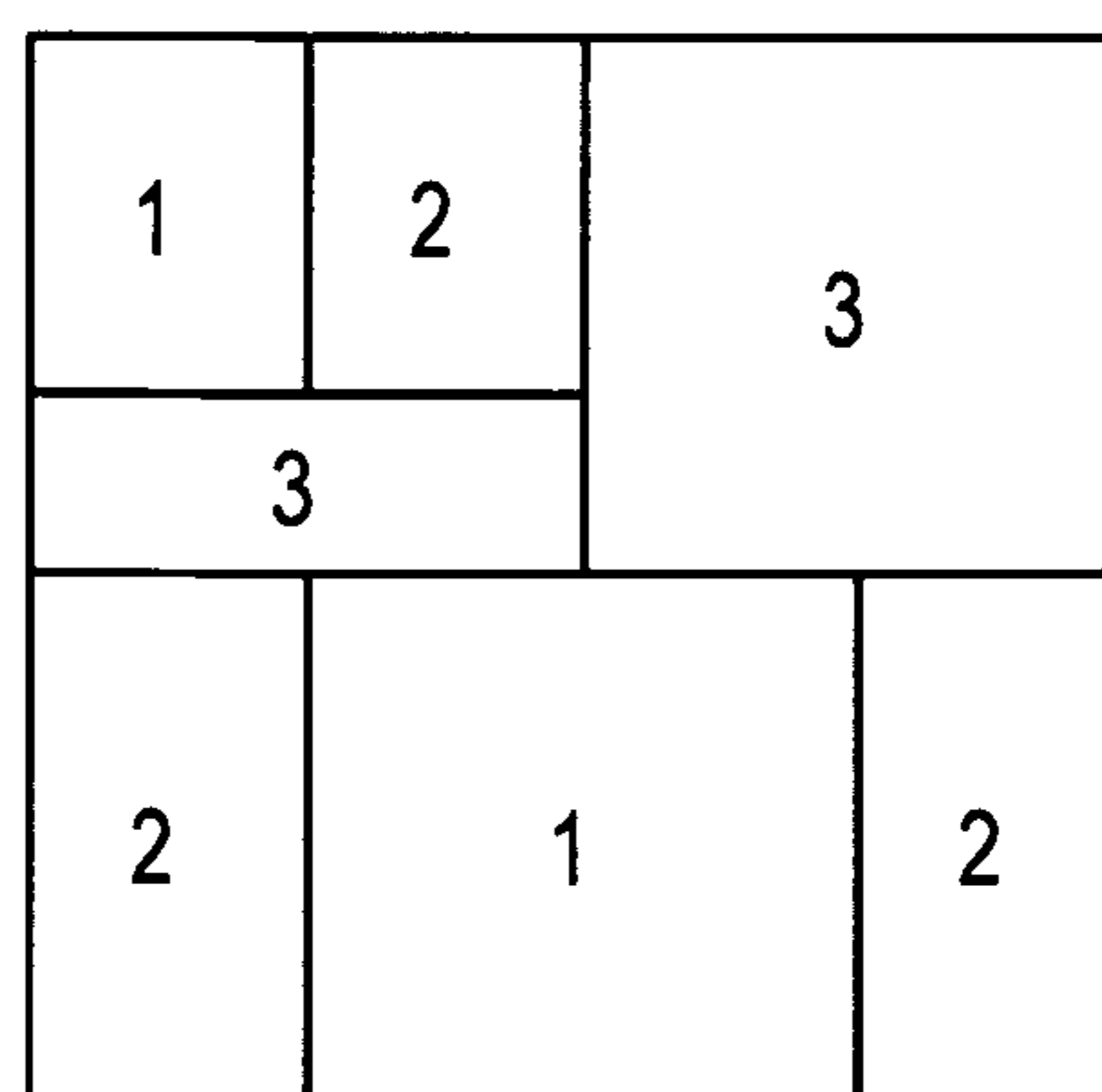

Fig. 16C

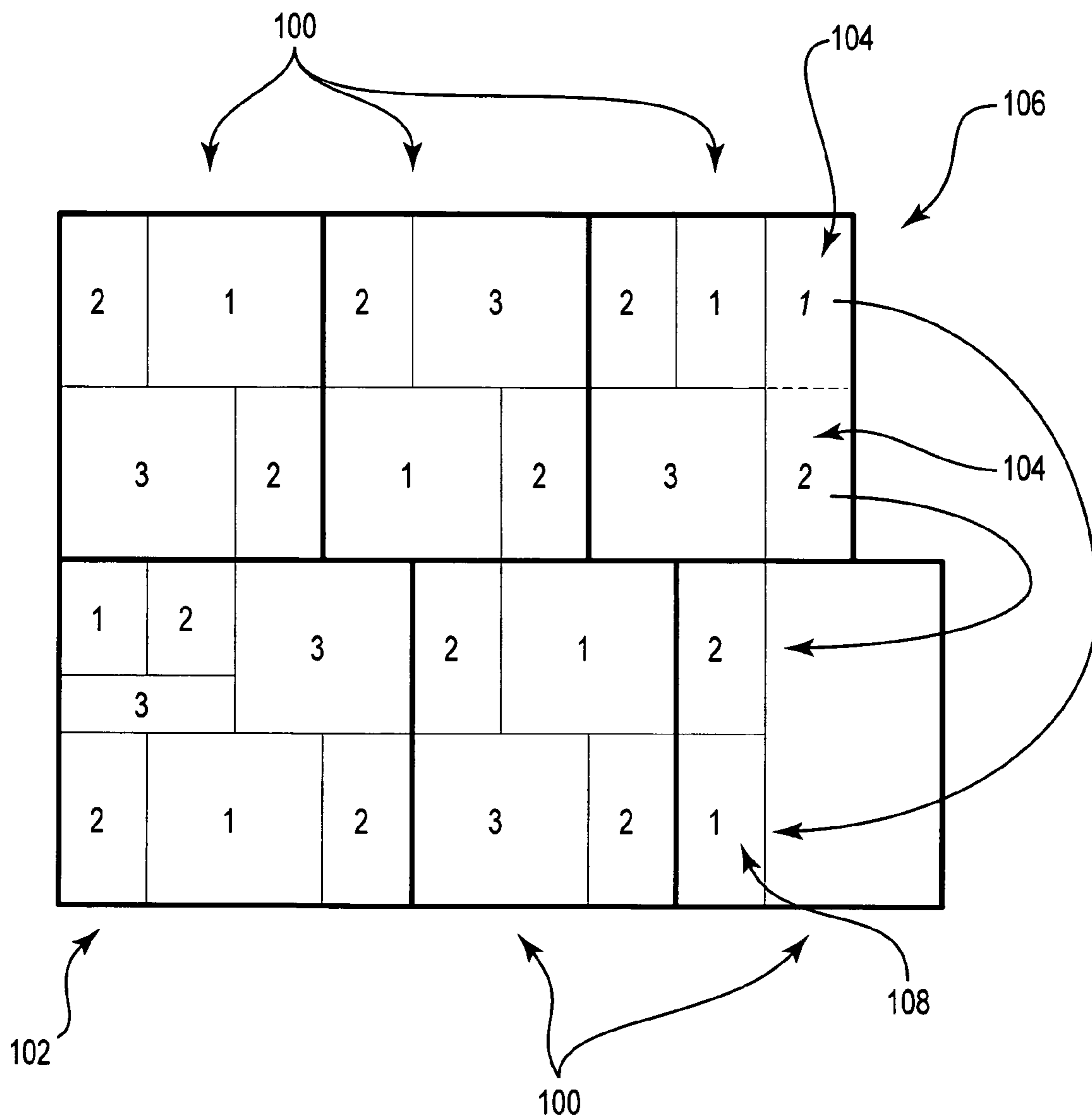

Fig. 16D

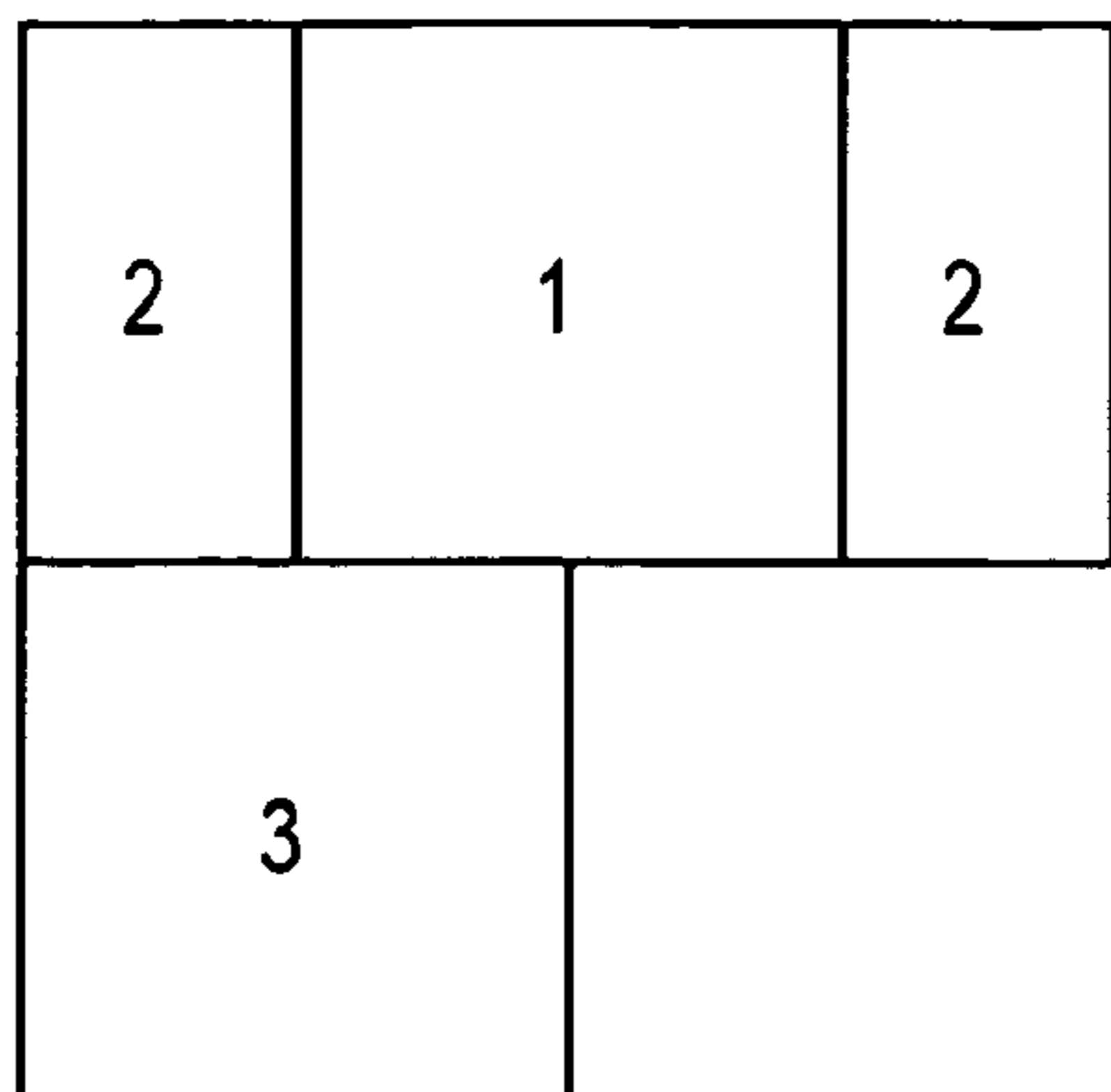

Fig. 17A

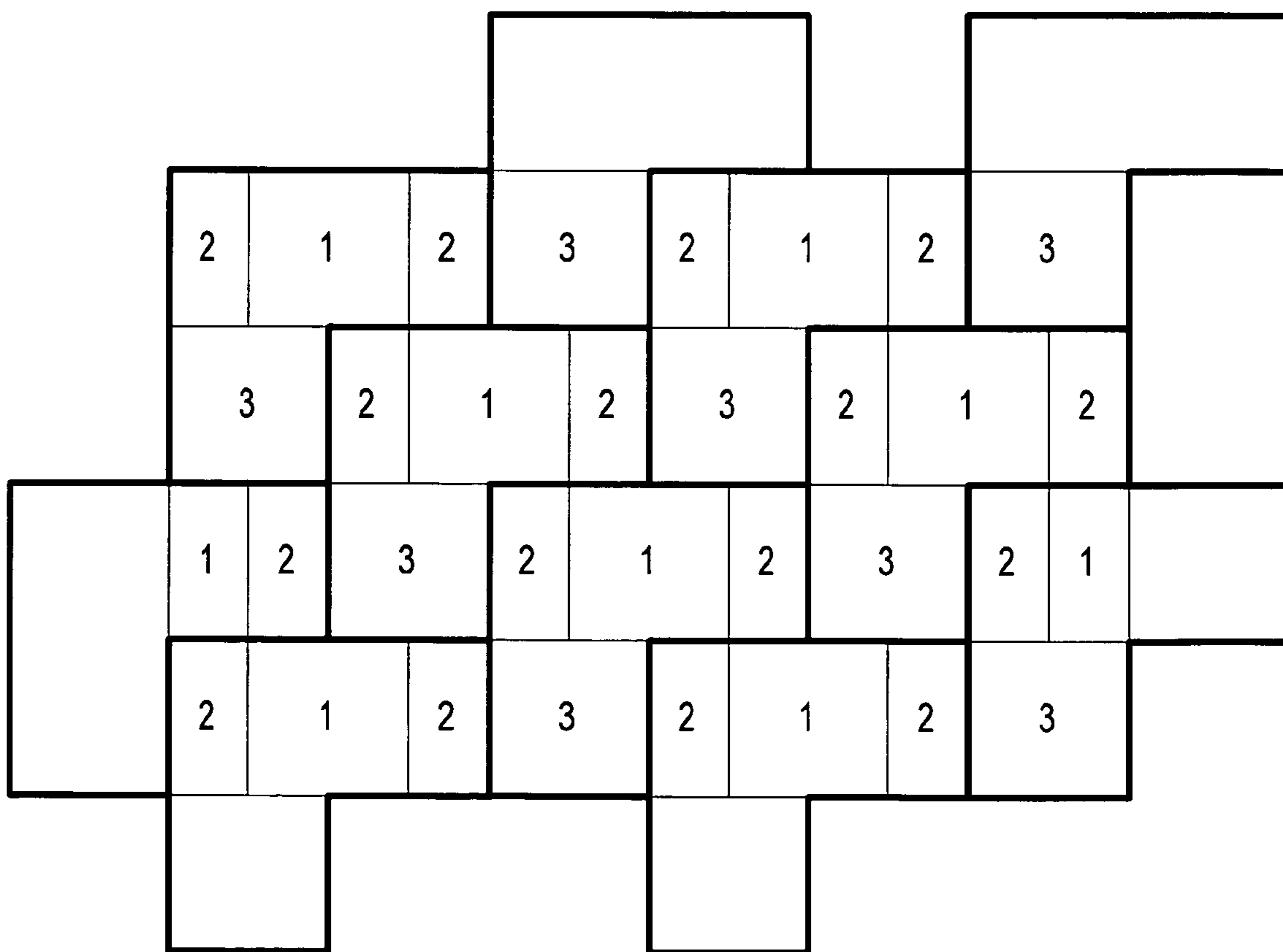

Fig. 17B

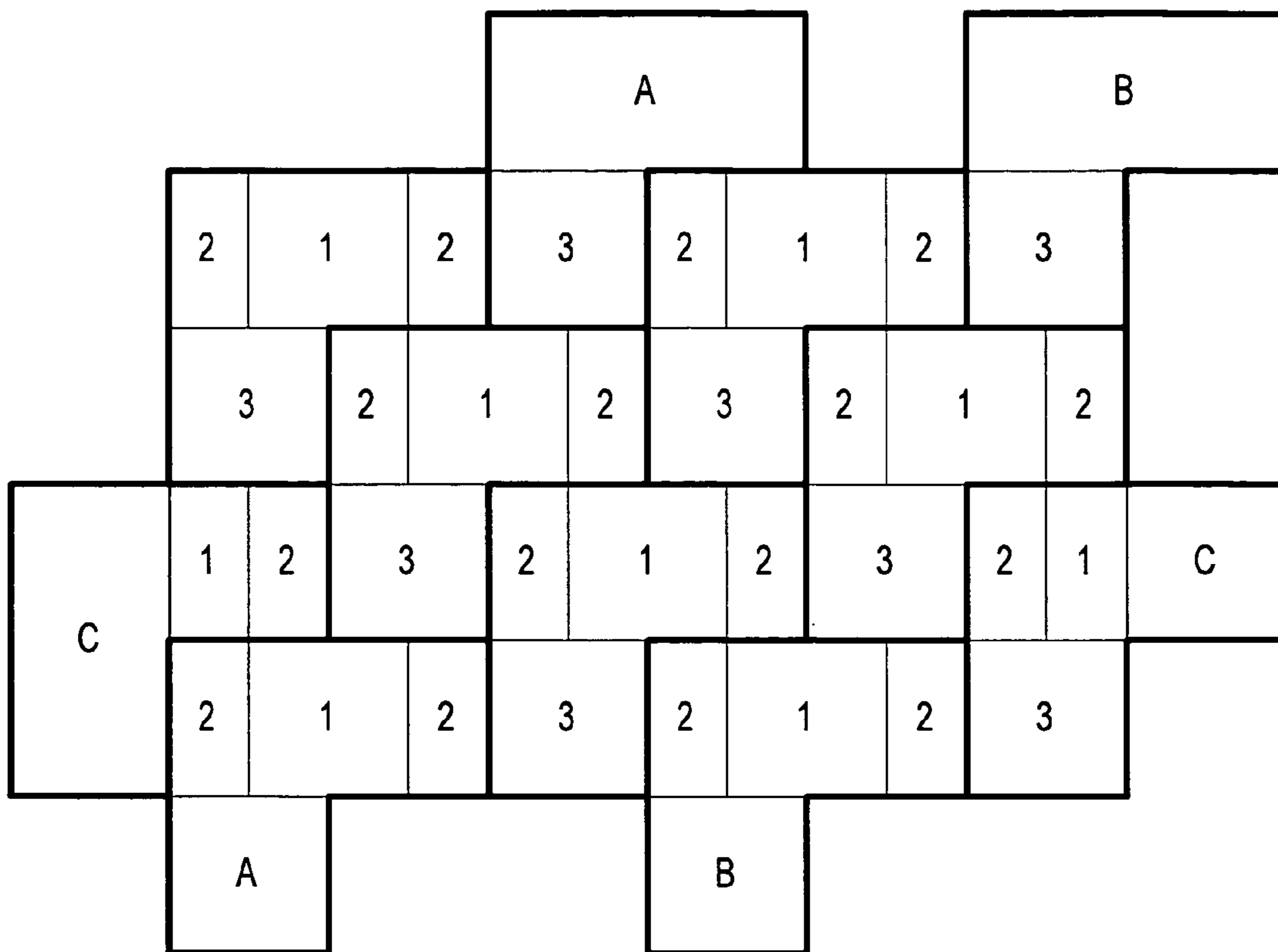

Fig. 17C

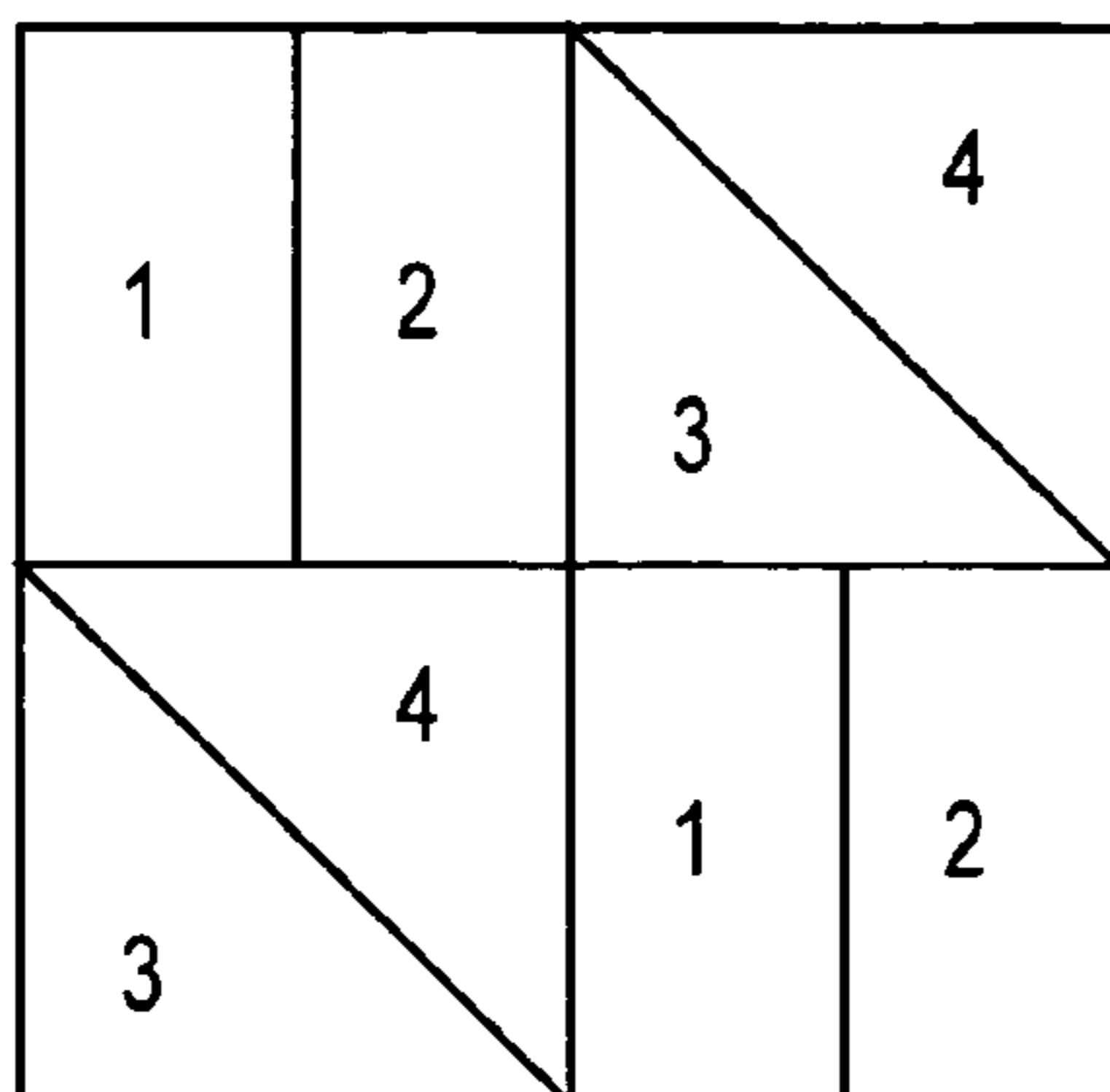

Fig. 18A

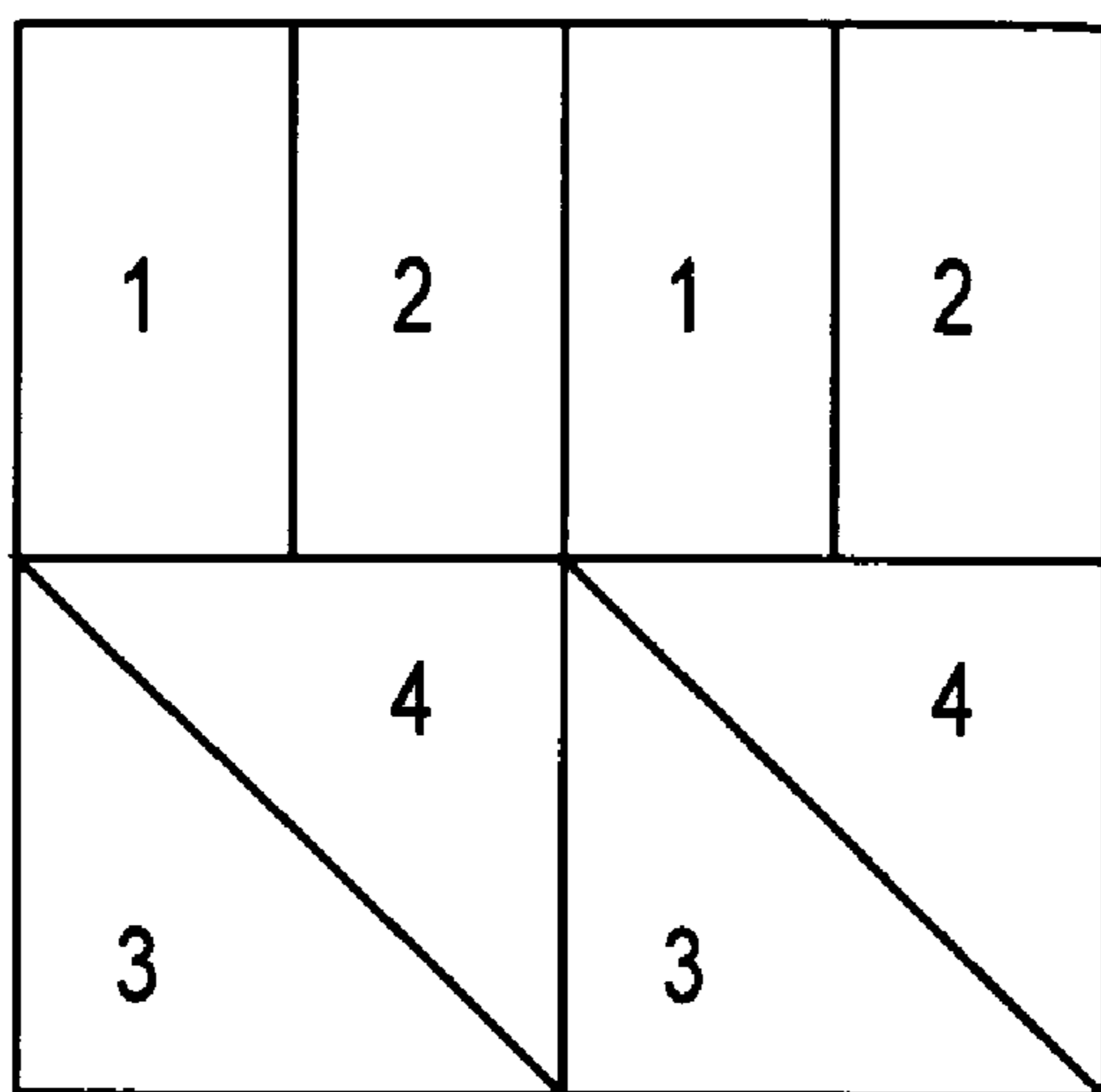

Fig. 18B

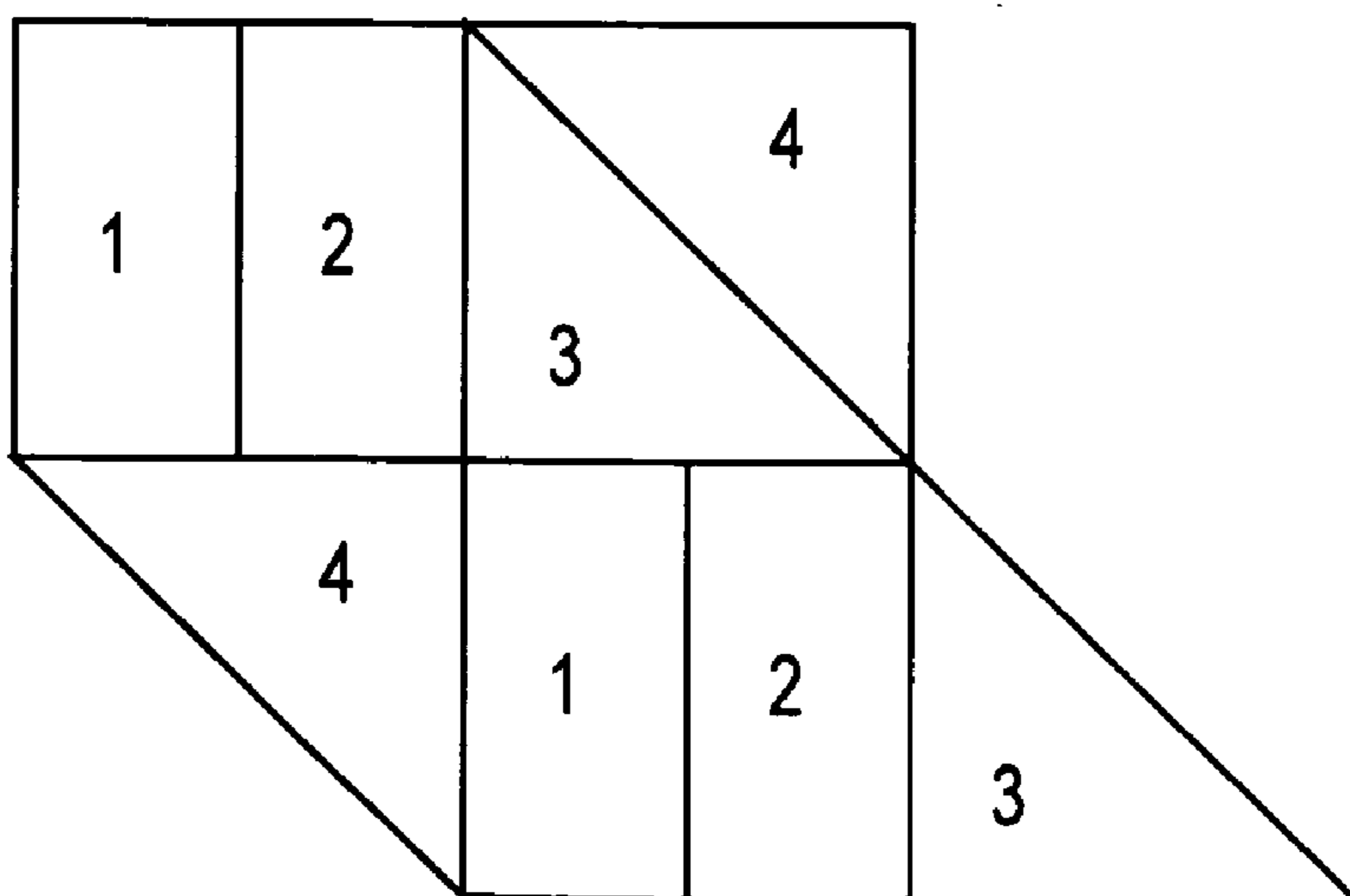

Fig. 18C

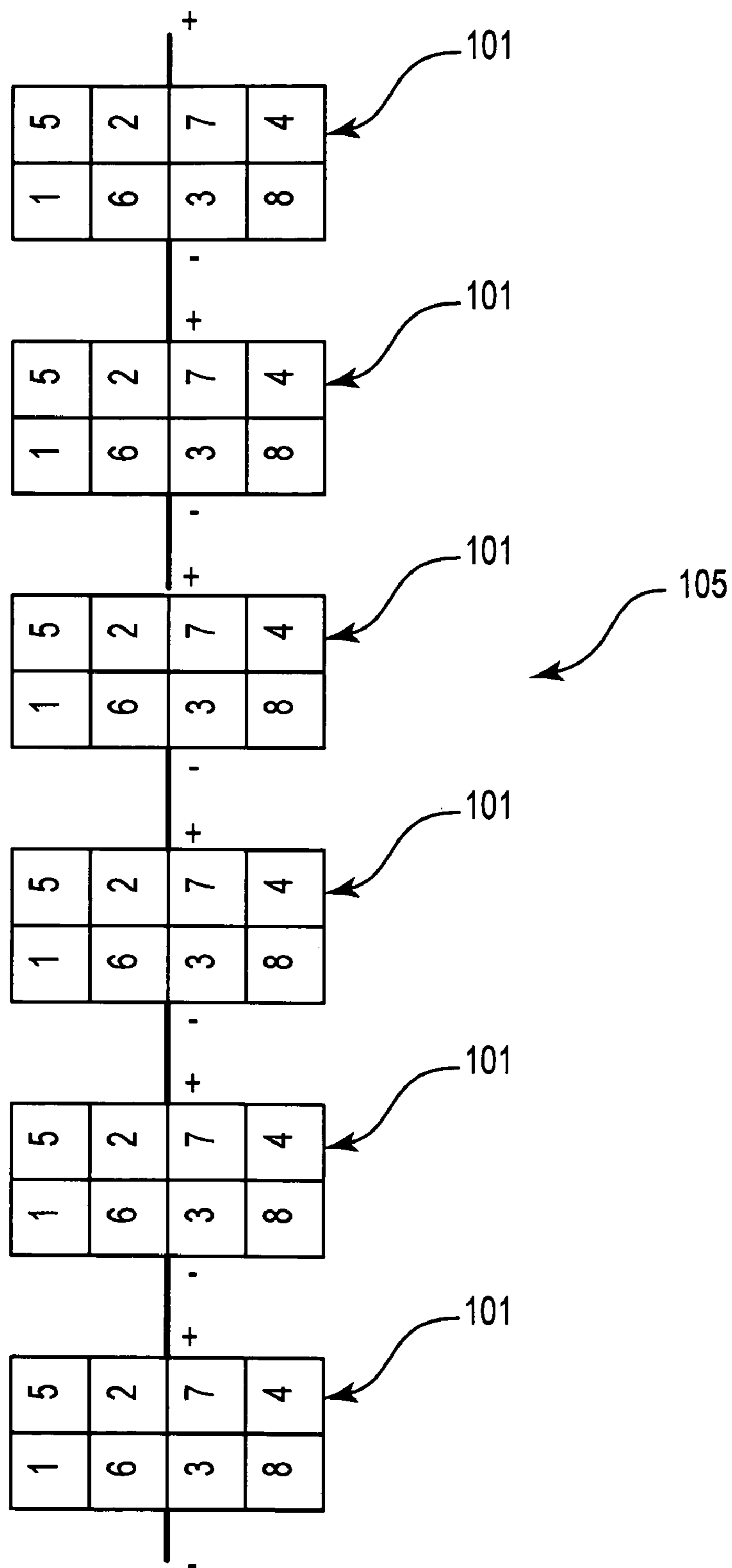

Fig. 19A

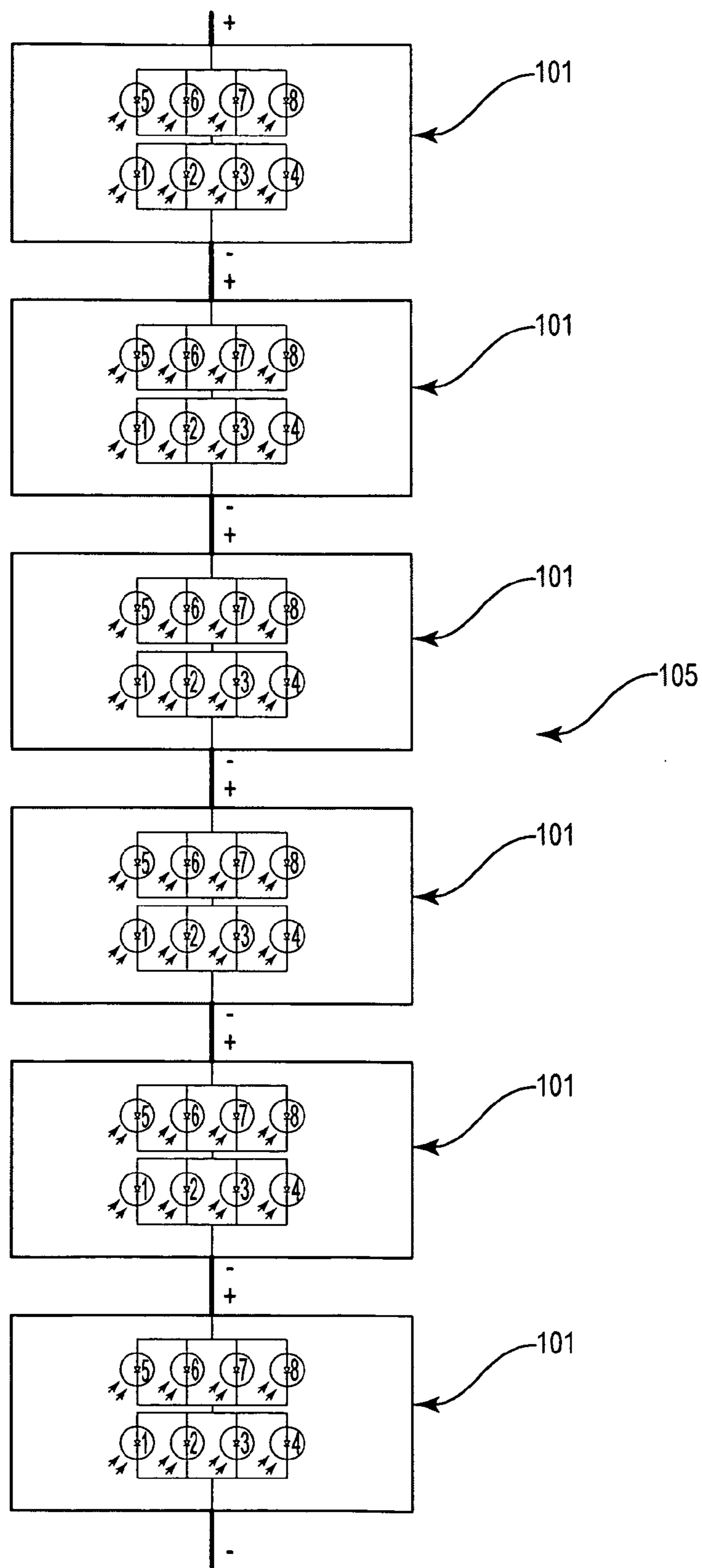

Fig. 19B

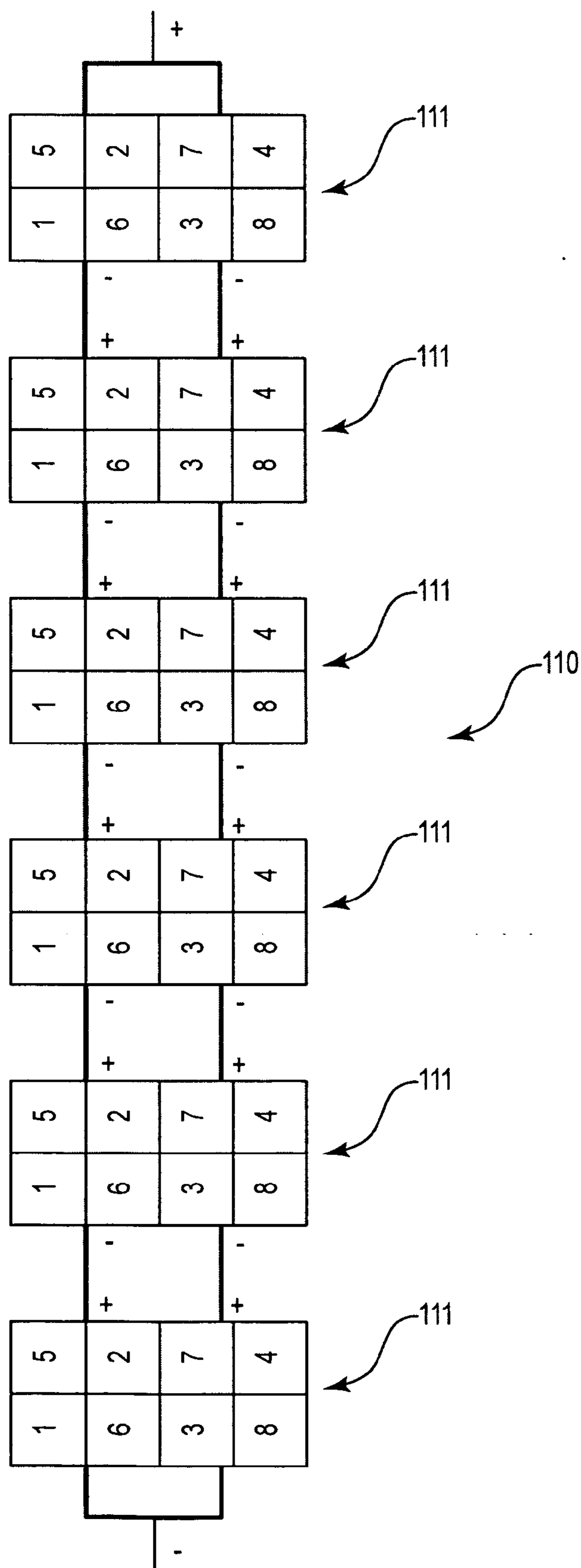

Fig. 19C

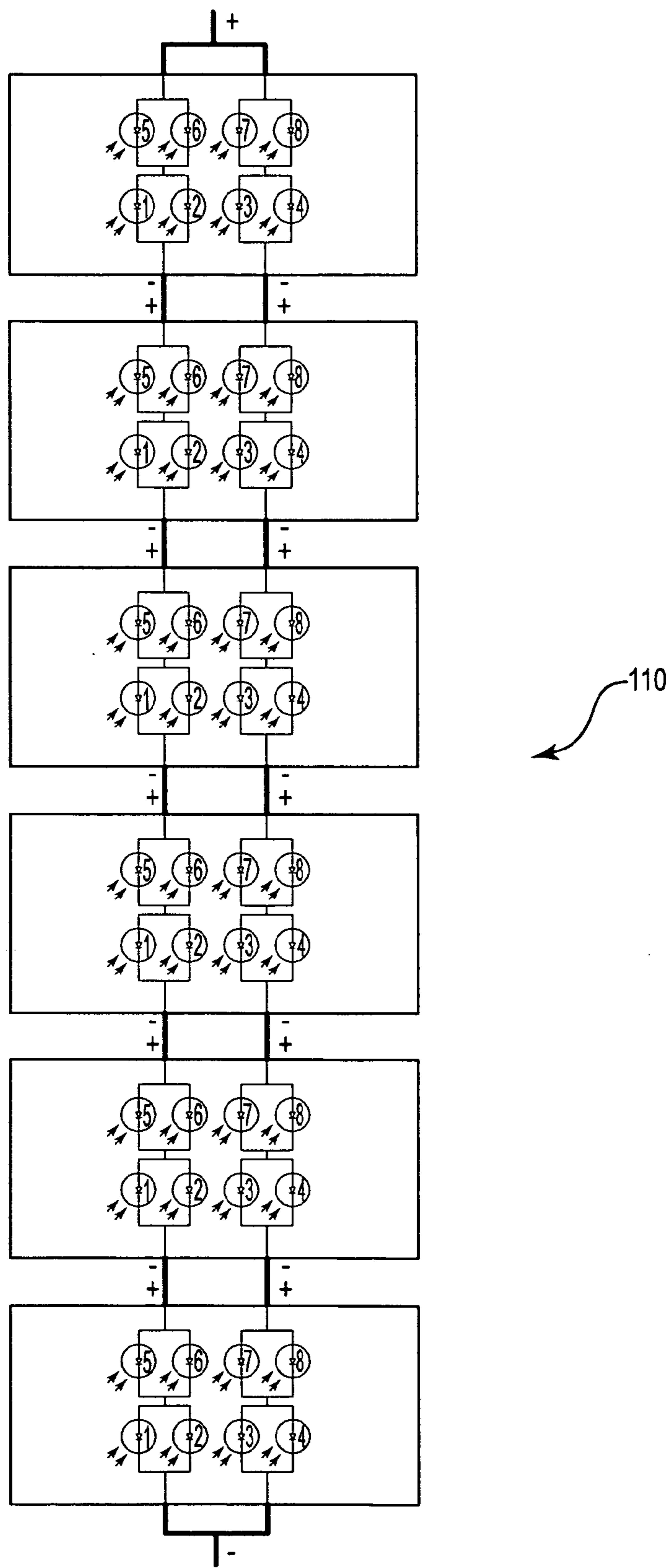
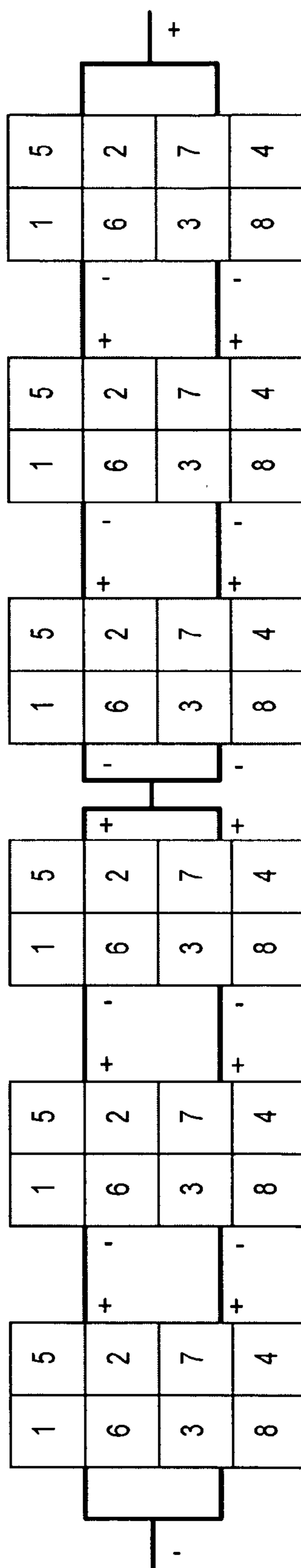

Fig. 19D



115

Fig. 19E

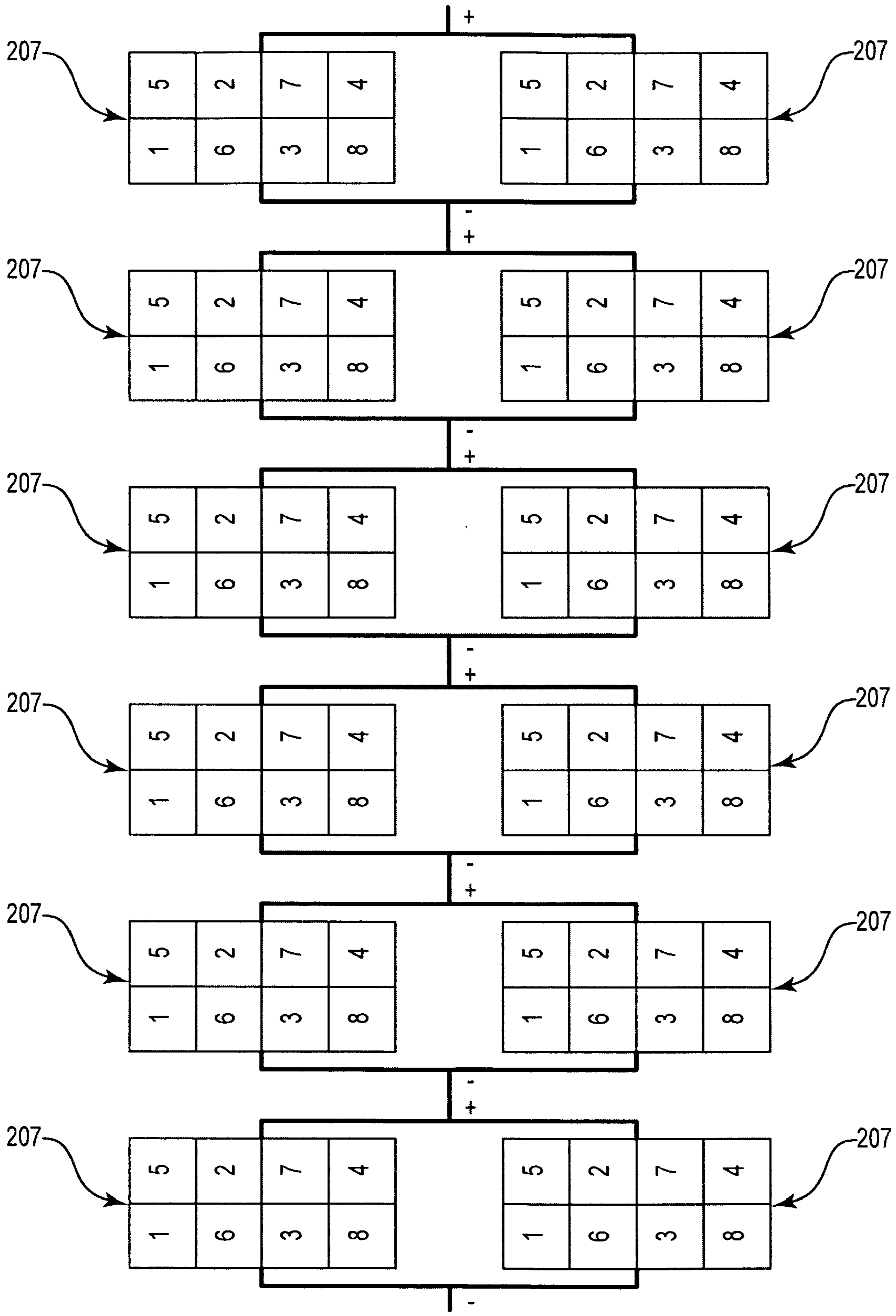

Fig. 19F

**SOLAR SYSTEMS THAT INCLUDE ONE OR
MORE SHADE-TOLERANT WIRING
SCHEMES**

PRIORITY CLAIM

[0001] The present non-provisional patent Application claims priority under 35 U.S.C. §119(e) from United States Provisional patent application having Ser. No. 61/128,009, filed on May 16, 2008, by Hines et al. and titled CONCENTRATING PHOTOVOLTAIC SOLAR PANEL, from United States Provisional patent application having Ser. No. 61/131,178, filed on Jun. 6, 2008, by Hines et al. and titled CONCENTRATING PHOTOVOLTAIC SOLAR PANEL, and from United States Provisional patent application having Ser. No. 61/209,526, filed on Mar. 6, 2009, by Baker et al. and titled SOLAR SYSTEMS THAT INCLUDE ONE OR MORE SHADE-TOLERANT WIRING SCHEMES, wherein the respective entireties of said provisional patent applications are incorporated herein by reference.

STATEMENT REGARDING FEDERALLY
SPONSORED RESEARCH OR DEVELOPMENT

[0002] The present invention was made with Government support under Cooperative Agreement No. DE-FC36-07G017044 awarded by the U.S. Department of Energy. The Government has certain rights in this invention.

FIELD OF THE INVENTION

[0003] The present invention relates to photovoltaic power systems, standard photovoltaic modules, photovoltaic concentrator modules, and related devices and methods.

BACKGROUND OF THE INVENTION

[0004] Solar panels are generally well known (see, e.g., U.S. Pub. No. 2006/0283497(Hines)). It is desirable to produce solar power systems (e.g., solar panels) that produce more power and/or that cost less.

[0005] One approach has been to attempt to produce more power per panel by orienting the solar panels at a fixed tilt relative to the ground. For example, a solar panel installed in the continental United States might be installed tilted 20 degrees towards the south.

[0006] A second approach has been to install solar panels on trackers, so that the panels follow the sun, resulting in more direct radiation on the solar panel over the course of a day and/or year.

[0007] However, when solar panels are not installed flat, they tend to cast shadows. Traditionally, solar panels are not especially tolerant of shadows. For example, the output of a solar panel may drop to zero even if only a small fraction of the panel is shadowed.

[0008] Therefore, when solar panels are installed at a static tilt or on trackers, it is common to space the panels apart so that the panels do not shadow each other to an undue degree (e.g., most of the time). For example, the single-axis tracking system 10 shown in FIG. 1 illustrates spacing sufficient to avoid shadowing from adjacent rows 11. Similarly, more elaborate trackers and tilted systems require still more spacing, as shown by the tilted-axis trackers 12 in FIG. 2.

[0009] While such spacing helps each solar panel to produce a high amount of energy, it does not make efficient use of space, whether it be land as shown in the FIG. 1 and 2, or rooftop space in the case of a rooftop installation.

[0010] It is desirable, therefore, to provide solar panels that are tolerant of shadowing in order to help make better use of available space, allowing more solar energy production from a given space.

[0011] Statically tilted or tracking solar panel systems may include both traditional flat-plate silicon modules as well as solar concentrator modules, such as those commercially available by companies such as SunPower or Sharp, and those described in U.S. Pub. No. 2006/0283497 (Hines), respectively.

[0012] Conventional photovoltaic solar panels tend to lack shadow tolerance because of the properties of the individual solar cells and because of the way photovoltaic systems are typically wired together. In order to produce a desired output voltage, strings of solar cells are typically wired together in series, and then these series strings can be wired together in parallel to produce a desired output current.

[0013] The equivalent circuit for a single solar cell, as shown in FIG. 3, includes a diode 21 wired in parallel with a current source 22. The diode 21 represents the large area semiconductor junction or junctions that are formed by the solar cell material. The current source 22 models the photovoltaic current I_{ph} that is generated when light shines on it. Resistor R_p models the shunt resistance, and resistor R_s models the series resistance of the cell package (e.g., contact resistance and the like). Note that current flowing through an illuminated photovoltaic cell actually flows from the cathode to the anode, the opposite of a standard non-illuminated diode that is conducting. However, when a photovoltaic cell is not illuminated, it just becomes an ordinary diode, capable of conducting only from anode to cathode.

[0014] As shown in FIG. 4, photovoltaic cells 30 receiving incident light 40 are typically wired together into a series "string" 32, in order to produce a desired voltage V_{string} , which may be as high as 600V in some cases. FIGS. 4-10 include a dashed line which indicates that the string can include any multiplicity of cells 30. For example, any number of cells 30 wired in series and/or any number of series strings wired in parallel. Generally, a rectangular matrix is formed.

[0015] As shown in FIG. 5, multiple strings 32 of cells 30 receiving incident light 40 are typically wired together in parallel in order to produce a desired total current and thus total power, which is fed to an inverter 34, which conditions the output power into a form that is compatible with the electric power grid.

[0016] However, when an individual solar cell 30 becomes shadowed, as shown in FIG. 6A, wherein some shadowing object 38 is blocking the light 40 from reaching the cell, the internal current source I_{ph} of the shadowed cell drops to zero current, and thus the shadowed cell instead operates as a normal diode 42, such that the shadowed solar cell essentially becomes an open circuit, as shown in FIG. 6B, wherein the diode 42 is represented by an open switch 44. Thus, no current flows in the string, and thus no power is produced, even though all of the other non-shadowed solar cells 30 in the string are capable of producing power were it not for the shadowed solar cell.

[0017] To help mitigate this problem, it is common in the art to provide one or more bypass diodes 46, as shown in FIG. 7, in order to provide an alternate path for current to flow. In FIG. 7, the shadowed cell 45 is represented as a photodiode, but is double-cross-hatched to represent its being fully shadowed. Regrettably however, while bypass diode 46 permits current to flow in the string and thus extract power from the

other photovoltaic cells **30** in the string, the bypass diode **46**, by virtue of its intrinsic forward voltage drop, typically approximately 0.5V, actually dissipates a certain amount of power.

[0018] FIG. 8 illustrates the effect when the photovoltaic cell **47** is partially shadowed—half shadowed in the case shown here (as indicated by the single-cross-hatching), by a partial obscuration object **48**. In such a case, the half-shadowed photovoltaic cell **47** could produce half the power were it connected in a favorably configured circuit. As wired, the combined current of the cell **47** and bypass diode **46** must total the output current of the string I_o . In this example, however, the bypass diode **46** is turned on resulting in a voltage drop across the photovoltaic cell **47** instead of a voltage increase. Consequently both bypass diode **46** and photovoltaic cell **47** dissipate power rather than generate power to the output circuit.

[0019] In fact, this regrettable situation continues to occur even as the partially shadowed cell **47** approaches nearly complete illumination (i.e., becomes non-shadowed); for example, assuming typical inverter behavior and fully illuminated parallel strings, then even at 90% illumination, the partially shaded cell **47** will continue to be bypassed if all the other cells **30** in the chain are 100% illuminated.

[0020] In fact, further exacerbating this problem, general practice is not to include a bypass diode **46** for every individual solar cells **30** and **47**, but to include a single bypass diode around a group of solar cells, or even around an entire solar submodule or module, thus regrettably leading to an even greater loss of potential power by virtue of bypassing completely illuminated cells in addition to a partially shaded cell or cells.

SUMMARY OF THE INVENTION

[0021] The present invention provides numerous solutions that are helpful singly or in combination to overcome and/or alleviate one or more of the problems present in prior art photovoltaic solar cell strings.

[0022] For example, the present invention can provide a photovoltaic solar module and/or system that can exhibit improved shadow tolerance relative to a module or system using traditional bypassing techniques, by providing one or more wiring schemes that allow partially shadowed solar cells to contribute output power to a series string. Advantageously, using such wiring schemes can help avoid the activation of bypass diodes with their concomitant power consumption.

[0023] The present invention first considers a hypothetically ideal partial bypassing component—a supplemental current source **50** that provides exactly the correct amount of current to complement the current lost in the partially shadowed solar cell **47**, as shown in FIG. 9. In FIG. 9, the solar cell **47** is shown to be 40% shadowed, and thus producing 60% of the current of the fully illuminated cells **30**. The supplemental current source **50** therefore would ideally provide 40% of the current of the fully illuminated cells **30**. In the situation where the supplemental current source is provided by an external power source (e.g. the power grid), the amount of power consumed by the current source **50** is equal to supplemental current times the voltage across the partially shadowed cell **47**. The net power gain or loss is therefore the difference between the photocurrent generated by the partially shadowed cell **47** and the supplemental current source **50** multiplied by the voltage across them. Given this arrangement,

whenever the cell is more than 50% illuminated, there is a net gain in power generated by the photovoltaic string.

[0024] Next, the present invention appreciates that if a large array of solar cells includes some fully shadowed cells, some partially shadowed cells, and some unshadowed cells, then it may be possible, through intelligent, dynamic rewiring of the overall series-parallel circuit of the solar array, to maximize the power output of the system. By way of a simple example, FIG. 10 illustrates a case where one photovoltaic cell **47** is partially shadowed, but has been wired in parallel with another photovoltaic cell **52** that is partially shadowed by a complementary amount, thus achieving full energy harvest from the pair of partially shadowed cells **47** and **52**, with no parasitic power dissipation in bypass diodes. The sum of the currents for cells **47** and **52** equals the current of the cells **30** wired in series.

[0025] It is theoretically possible to do this sort of dynamic rewiring for an entire solar array with, e.g., a massive central “switchboard” into which all the solar cell leads are input, with said switchboard including a relatively large array of lossless switches, controlled by an intelligent computer that could alternately sample the current through each solar cell in the array and then rewire the cells for optimal power output. A practical implementation of such a system, however, may pose significant challenges and costs thereby limiting its utility.

[0026] The present invention also teaches that patterns of light and shadow on a solar panel tend to be highly correlated and systematic, so that much of the benefit of an arbitrary-wiring central switchboard as discussed above in connection with FIG. 10 can be achieved with a much simpler static wiring approach that takes advantage of the systematic nature of the shadows that fall on the solar panel. The systematic nature of shadowing can arise because the primary shading source tends to be self-shading by adjacent solar modules that are either arranged at a fixed tilt or on tracking systems. For rooftop installations, other sources of shadowing include objects such as parapet walls, airconditioner units, and elevator shafts that tend to cast shadows having relatively simple geometry.

[0027] In particular, as shown in FIGS. 11A and 11B, a typical shadow **60** is not random but rather has a relatively simple structure (such as straight lines and a simple polygon), and it may be desirable to partition the aperture **62** of a solar submodule into sub-apertures **64** and then wire the solar cells **72** corresponding to some of the sub-apertures **64** in parallel into one group **66**, while wiring the solar cells **74** corresponding to the other subapertures **64** into one or more other groups **68**, and then producing a desired output voltage by wiring the groups into a series circuit **70**. Providing a multiplicity of parallel-wired groups **66** or **68** may allow the parallel-wired groups to receive similar amounts of total sunlight. By providing similar amounts of total sunlight to the multiplicity of parallel-wired groups, the groups then may be wired together in series without substantial loss of output power and without producing voltages which will forward bias shadowed solar cells or activate bypass diodes.

[0028] In the case of FIG. 11A, an aperture **62** of a solar panel is shown that includes eight distinct subapertures **64**, with a shadow that shadows 50% of each of subapertures #1 and #2, while fully shadowing subaperture #5. In this case, the wiring scheme shown in FIG. 11B will result in an approximately 100% harvest of the available energy, by balancing the photocurrents in the parallel groups of solar cells **66** and **68**.

[0029] In the context of a solar panel, a principle teaching of this invention, then, is the generalization of the example of FIGS. 11A and 11B and includes the steps of: 1) Dividing the aperture of a solar panel into subapertures whose solar cells can be wired together into any desired series-parallel pattern; 2) Wiring individual solar cells or groups of solar cells into groups of parallel circuits, where the total current of each parallel group is generally expected to be similar based on expected shadowing patterns; and 3) Preferably, wiring the parallel groups in series to produce a desired output voltage. The general concept of the invention permits an infinite number of levels of parallel-series groupings. In the simplest form, N1 groups are connected in series where each group has M1 cells connected in parallel. Building on the simplest form, a system X can have N2 groups connected in series where each group has M2 X's connected in parallel. Furthermore, an additional system Y can have N3 groups connected in series where each group has M3 Y's connected in parallel—ad infinitum. There can be practical limits to this arrangement. The general concept described above can be expanded to wiring individual solar and/or solar modules into groups of parallel circuits, where the total current of each parallel group is generally expected to be similar based on expected shadowing patterns and, preferably, wiring the parallel groups in series to produce a desired output voltage.

[0030] An approach using a wiring scheme according to the present invention is especially useful in cases where solar modules (and even more especially solar modules on trackers, including both concentrator modules and traditional flat plate modules (note: flat plate modules can also be referred to as solar panels)) are arrayed in close proximity to one another in regular patterns. When arrayed in these regular patterns, the shadow(s) that a solar module casts on its neighboring solar modules will typically be approximately identical to the shadow(s) casts by all the other solar modules in the system. Thus, arrays of regularly spaced solar will tend to cast the kinds of simple shadows that will make the overall array most amenable to the improvements taught by the present invention. As used herein, a solar panel is an example of a solar module and a solar collector is an example of a submodule.

[0031] Accordingly, the following optional “step 0” could be added prior to step 1 above: 0) Provide an array of solar panels in regularly spaced pattern(s) such that the shadows cast by individual solar panels on other solar panels among the array tend to be similar and have simple geometry, so as to inform the identification of 1) appropriate subapertures and groups of subapertures, 2) appropriate solar and groups of solar, and/or 3) appropriate solar modules and groups of solar modules.

[0032] By way of example of such an array, FIG. 12A illustrates an array of three concentrating solar panels or modules 2 (each solar panel 2 includes six collectors or 7) on a rooftop of the type described in applicant's co-pending application No. 61/128,009, filed May 16, 2008, entitled CONCENTRATING PHOTOVOLTAIC SOLAR PANEL, by Turk et al. (Attorney Docket Number: SE10033/P1) and co-pending application No. 61/131,178, filed Jun. 6, 2008, entitled CONCENTRATING PHOTOVOLTAIC SOLAR PANEL, by Turk et al. (Attorney Docket Number: SE10033/P2) illustrating the similarity of the shadows 4 cast by each solar panel on its neighbor(s), the entirety of said provisional patent applications are incorporated herein by reference for all purposes.

[0033] According to one aspect of the present invention, a photovoltaic solar system includes a plurality of solar electrically coupled in series. At least one of the solar has an aperture including a plurality of subapertures that independently focus incident light onto at least one solar cell. The solar cells of the subapertures are arranged in at least two groups of solar cells coupled in series. Each solar cell group includes at least two solar cells electrically coupled in parallel.

[0034] According to another aspect of the present invention, a solar, photovoltaic system includes at least one photovoltaic submodule. The at least one submodule includes a first group of photovoltaic cells including at least two photovoltaic cells wired in parallel, and a second group of photovoltaic cells including at least two photovoltaic cells wired in parallel. The at least two photovoltaic cells of the second group are different than the at least two photovoltaic cells of the first group. The first group and second group are wired in series.

[0035] According to another aspect of the present invention, a solar system includes a plurality of solar electrically coupled in series. At least one solar submodule includes a plurality of solar cells that independently capture incident light. The at least one submodule includes a first row of solar cells including at least first through fourth solar cells and a second row including at least fifth through eighth solar cells. The solar cells exist in at least two groups coupled in series. The first and second groups each include at least two solar cells from the first row and at least two solar cells from the second row. Each of the at least two solar cells from the first row and each of the at least two solar cells from the second row are electrically coupled in parallel with each other.

[0036] According to another aspect of the present invention, a photovoltaic solar system includes a plurality of solar modules electrically coupled in series. At least one solar module includes a plurality of solar that independently capture incident light. The solar are arranged in at least two groups coupled in series. Each submodule group includes at least two electrically coupled in parallel.

[0037] According to another aspect of the present invention, a solar system includes a plurality of solar electrically coupled in series. At least one solar submodule includes a plurality of targets that independently capture incident light. The at least one submodule includes a first row of targets including at least first through fourth targets and a second row including at least fifth through eighth targets. The targets exist in at least two groups coupled in series. The first and second groups each include at least two targets from the first row and at least two targets from the second row. Each of the at least two targets from the first row and each of the at least two targets from the second row are electrically coupled in parallel with each other.

[0038] According to another aspect of the present invention, a solar concentrator system includes a plurality of solar concentrator modules electrically coupled in series. At least one module includes first and second electrically coupled groups. Each group includes a plurality of electrically coupled to each other in parallel. Each submodule within each group is structurally positioned within a module such that each submodule is diagonally adjacent to at least one other submodule of the group.

[0039] According to another aspect of the present invention, a method of making a solar system includes the steps of: a) providing a plurality of solar modules; b) identifying two or more subaperture groups in a manner such that the sum of the

subaperture areas within each group is substantially equal among the subaperture groups; c) electrically coupling the solar cells associated with a subaperture group in parallel; and d) electrically coupling the submodule groups in series. At least one solar module includes a plurality of solar . Each submodule has an aperture including a plurality of subapertures. Each subaperture has an area that captures incident light and directs said light onto at least one solar cell.

[0040] According to another aspect of the present invention, a solar system includes a plurality of solar modules. At least one solar module includes two or more submodule groups. Each submodule group includes a plurality of solar . Each submodule has an aperture having an area that captures incident light. The sum of the submodule aperture areas within each group is substantially equal among the submodule groups. The with a submodule group are electrically coupled in parallel. The submodule groups are electrically coupled in series.

BRIEF DESCRIPTION OF THE DRAWINGS

[0041] FIG. 1 shows a prior art array of conventional photovoltaic modules mounted on spaced-apart single-axis trackers.

[0042] FIG. 2 shows a second prior art array of conventional photovoltaic modules mounted on spaced-apart, tilted single-axis trackers.

[0043] FIG. 3 shows an equivalent-circuit model of a solar cell, with generated photocurrent I_{ph} . FIG. 4 shows conventional wiring scheme for a string of solar cells of a solar collector/submodule.

[0044] FIG. 5 shows a conventional wiring scheme for multiple strings of solar cells of the type shown in FIG. 4.

[0045] FIG. 6A shows a cell of the string in FIG. 4 that is fully shadowed.

[0046] FIG. 6B shows the electrical effect on the string shown in FIG. 6A.

[0047] FIG. 7 shows the string in FIG. 6A that includes a bypass diode.

[0048] FIG. 8 shows a cell of the string in FIG. 4 that is partially shadowed.

[0049] FIG. 9 shows a hypothetical supplemental current source used in the string shown in FIG. 4.

[0050] FIG. 10 shows one embodiment of a wiring scheme according to the present invention for a string of solar cells.

[0051] FIG. 11 A shows the pattern of shadow on the aperture of a solar collector/submodule.

[0052] FIG. 11B shows another embodiment of a wiring scheme according to the present invention.

[0053] FIG. 12A shows an array of solar panels that incorporate a wiring scheme according to the present invention.

[0054] FIG. 12B shows a partial view of the array of solar panels shown in FIG. 12A, illustrating a shadow pattern.

[0055] FIG. 13 shows another embodiment of a wiring scheme according to the present invention for the shadowed solar panel shown in FIG. 12B.

[0056] FIG. 14A illustrates the subapertures of an aperture of a solar collector.

[0057] FIG. 14B shows an aperture of a solar collector having relatively smaller subapertures as compared to the subapertures shown in FIG. 14A.

[0058] FIG. 15A shows another embodiment of a wiring scheme according to the present invention.

[0059] FIG. 15B shows the subaperture layout corresponding to the wiring scheme shown in FIG. 15A.

[0060] FIG. 15C shows the repeating tile of subapertures used to make the aperture shown in FIG. 15B.

[0061] FIG. 15D shows how whole multiples of the repeating tile shown in FIG. 15C are used to make the aperture shown in FIG. 15B.

[0062] FIG. 16A shows another subaperture layout for a given aperture of a solar collector.

[0063] FIG. 16B shows a first type of repeating tile of subapertures used to make the aperture in FIG. 16A

[0064] FIG. 16C shows a second type of repeating tile of subapertures used to make the aperture in FIG. 16A.

[0065] FIG. 16D shows how whole multiples of each of the repeating tiles shown in FIGS. 16B and 16C are used to make the aperture shown in FIG. 16A.

[0066] FIG. 17A shows another type of repeating tile of subapertures that can be used to make an aperture of a solar collector/submodule.

[0067] FIGS. 17B and 17C show how whole multiples of the repeating tile shown in FIG. 17A is used to make the aperture shown in FIG. 17A.

[0068] FIG. 18A shows another type of repeating tile of subapertures that can be used to make an aperture of a solar collector/submodule.

[0069] FIG. 18B shows an alternative type of repeating tile of subapertures that can be used to make an aperture of a solar collector/submodule.

[0070] FIG. 18C shows yet another alternative type of repeating tile of subapertures that can be used to make an aperture of a solar collector/submodule.

[0071] FIG. 19A shows a preferred wiring scheme according to the present invention for electrically coupling multiple solar collectors together.

[0072] FIG. 19B shows a more detailed view of the wiring scheme shown in FIG. 19A.

[0073] FIG. 19C shows an alternative wiring scheme according to the present invention for electrically coupling multiple solar collectors together.

[0074] FIG. 19D shows a more detailed view of the wiring scheme shown in FIG. 19C.

[0075] FIG. 19E shows yet another alternative wiring scheme according to the present invention for electrically coupling multiple solar collectors together.

[0076] FIG. 19F shows an alternative embodiment according to the present invention.

DETAILED DESCRIPTION

[0077] The embodiments of the present invention described below are not intended to be exhaustive or to limit the invention to the precise forms disclosed in the following detailed description. Rather the embodiments are chosen and described so that others skilled in the art may appreciate and understand the principles and practices of the present invention.

[0078] In particular, while a preferred embodiment shown is a concentrating photovoltaic module, the methods and techniques taught by the invention apply equally well to ordinary solar panels that do not make use of concentration; the invention applies in any case where the (concentrating or not) photovoltaic module includes subapertures whose light is respectively collected on individual solar cells or groups of solar cells.

[0079] In the embodiments described below, the same reference characters are used to describe features that are the same among the embodiments.

[0080] As used herein, a sub-aperture generally has a one to one correspondence with a photovoltaic cell. So in any circumstance, an aperture overlying multiple solar cells can be recharacterized as multiple subapertures, where each subaperture has a one to one correspondence with each solar cell.

[0081] A first embodiment of a photovoltaic power system, according to the present invention, is shown in FIG. 12A. Photovoltaic power system 1 includes a plurality of individual photovoltaic collectors 7. Photovoltaic power system 1 may include any sort of photovoltaic module, including concentrating solar panels 2 as shown in FIG. 12A, or traditional solar panels as shown in FIGS. 1 and 2. Referring to FIG. 12A, individual solar panels 2 tend to cast shadows 4 that may, at certain times of the day or year, partially shadow adjacent solar panels 2.

[0082] Each photovoltaic collectors 7 can include multiple solar cells (not shown) wired together in series-parallel combinations. A given collector 7 may be considered to be divided into apertures 62 and/or subapertures 64, as shown in FIG. 12B. In the case of a traditional solar panel, the subapertures 64 are just the areas of the individual solar cells themselves; in the case of a solar concentrator, a subaperture 64 is typically the portion of the input aperture 62 that is focused onto a single solar cell (not shown). In either case, a single subaperture may focus onto a plurality of solar cells (such as a small solar cell array), or a single subaperture may comprise a plurality of individual solar cells, in the case of a traditional solar panel.

[0083] As discussed above, the present invention appreciates that shadowing-induced performance impairment of a solar panel occurs when the available photocurrents through different elements of a series string are not equal. If the currents could somehow be made equal—perhaps by providing a supplemental current source to aid partially illuminated cells, then it would be possible to harvest power from even these partially illuminated cells. Such a hypothetical “supplemental current” 50 is shown in FIG. 9, which illustrates a current source in parallel with a partially illuminated cell 47. While it may be possible to implement such a circuit, the supplemental current source 50 requires power to operate. In the case of a weak cell 47 which is producing less than half the photocurrent of the other cells in its string, the power required by the supplemental current source 50 will exceed the current produced by the weak cell 47.

[0084] The present invention considers that an alternative approach in a partially shadowed solar panel 2, such as in FIG. 12A, would be to intelligently re-wire solar cells within a collector 7 together in series-parallel groups as shadows move across the panel 2. If groups of cells are wired in parallel, and then those groups are wired in series, then the currents can be made equal by intelligently combining cells into parallel groups of one or more cells such that the sum of the currents within each group is substantially the same across all groups. (It may not be possible to combine cells perfectly in all cases but there will be an optimum combination to extract the most power). A very simple example of this is shown in FIG. 10, wherein two partially shadowed cells 47 and 52 are wired in parallel to produce the same total photocurrent as fully illuminated cells 30.

[0085] A hypothetical system, therefore, could connect the leads from each solar cell 30, 47, 52, etc. to a large intelligent multi-switch, which is capable of arbitrarily re-wiring the solar cells into series-parallel circuits as required in order to achieve equal currents among each group of parallel wired

cells. However, it can be challenging to implement such a switch without some disadvantage, such as power loss in the case of diodes, or expense and control complexity in the case of relays or more efficient semiconductor elements. While such an implementation may be challenging for some relatively larger systems, the present invention does appreciate that such a “central switchboard” may represent a viable embodiment of the concepts herein.

[0086] However, since shadowing patterns are typically not completely arbitrary, the present invention explores the possibility of static series-parallel wiring arrangements which may be able to achieve the goals of the intelligent multi-switch in the presence of typical shadowing patterns.

[0087] A simple exemplary solution to this problem has been disclosed in co-pending application No. 61/131,178, filed Jun. 6, 2008, entitled CONCENTRATING PHOTOVOLTAIC SOLAR PANEL, by Turk et al. (Attorney Docket Number: SE10033/P2), wherein said provisional patent application is incorporated herein by reference for all purposes. As discussed above, this exemplary solution is illustrated in FIGS. 1A and 1B. Applicants appreciate that this exemplary solution can apply to any sort of subapertures, shadowing patterns, and wiring requirements.

[0088] Describing this concept in general terms, the present invention teaches that it is desirable to organize the solar cells (or series strings of solar cells) within a solar submodule (or among multiple solar) into groups of parallel circuits which will tend to have similar total currents, and then to preferably wire these groups in series. Expanding this concept, the present invention can apply to any solar unit or subunit that could benefit from such shade tolerant wiring. For example, the present invention can apply to solar (or series strings of solar) within a solar module (or among multiple solar modules) into groups of parallel circuits which will tend to have similar total currents, and then to preferably wire these groups in series. As another example, the present invention can apply to solar modules (or series strings of solar modules) within a solar system into groups of parallel circuits which will tend to have similar total currents, and then to preferably wire these groups in series.

[0089] A simple approach would be to wire all of the solar cells of an entire solar panel, or even of an entire photovoltaic system, in parallel, thus avoiding any need to match currents in a series-connected chain. However, such a solution would have the disadvantage of producing an unduly high current at an unduly low voltage, which is not a practical implementation. Desirable systems produce relatively high voltages, for example 400-600V for a typical commercial installation, thus solar cells (or parallel groups of solar cells) are preferably wired together in series.

[0090] The present invention teaches that one approach to producing a desired higher voltage is to wire the solar cells associated with similarly shadowed subapertures in parallel so that the total current for a first group of cells wired in parallel is substantially the same as the total current for each of the other group(s) of cells wired in parallel, and then wire those parallel groups in series. It is typically a property of uniformly arrayed tracked solar (e.g., collector 7 shown in FIG. 12A) that the shadows cast by the collectors 7 onto adjacent collectors 7 of an adjacent panel 2 tend to be regular and patterned, resulting in similarly shadowed aperture groups on adjacent collectors 7. By way of example, one realistic shadowing situation is shown in FIG. 12B, which illustrates the shadows 4 from one concentrating solar panel 2

falling on a second concentrating solar panel 2. Concentrating solar panel 2 includes collectors 7, each collector 7 includes an aperture 62, and each aperture 62 includes a group of subapertures 64 which are numbered 1-8 for each aperture 62. The solar cells (not shown) associated with each subaperture 64 may then be collected into a series-parallel circuit as shown in FIG. 13. In such a situation, inasmuch as the total illumination of a subaperture group closely matches that of each of the other subaperture groups, the fact that individual solar cells produce more or less current than others is permissible—each solar cell still nearly fully contributes its individual photocurrent to power production so that the total current for each group is the same among the groups. In the case illustrated in FIG. 12B, the shadow 4 from the adjacent concentrating solar panel 2 covers one-third of each subaperture #4, while it generally covers two-ninths of (all but one of) each subaperture #8 of concentrating solar panel 2.

[0091] Referring further to FIG. 13, illustrating the wiring of solar cells 82 corresponding to each subaperture 64, with this shadowing pattern, then, each of the two parallel groups will produce three-and-two-thirds times the current I_o of an unshadowed subaperture. Since the areas of the shadows on subapertures #4 and #8 are not perfectly matched, a small amount of current is still lost—in this case, subaperture #8 was capable of producing seven-ninths the current I_o of an unshadowed aperture, but since the group consisting of subapertures (#1, #2, #3, #4) is only producing $3\frac{2}{3} I_o$ worth of current, the extra $\frac{1}{9}$ available in group (#5, #6, #7, #8) is lost. This is illustrated by the $\frac{7}{9} I_o$ associated with solar cell 82, associated with subaperture #8, being struck through and replaced by $\frac{2}{3} I_o$, the amount of current that is actually available. Note that, in a real system, the lost $\frac{1}{9}$ will not all come at the expense of subaperture #8 as shown; in practice, the $\frac{1}{9}$ loss will be shared amongst the four subapertures (#5, #6, #7, #8), with the particulars depending on the voltage setpoint for the entire array as chosen by an inverter such as inverter 34. As can be seen from FIGS. 12B and 13, solar cells associated with diagonally adjacent subapertures are wired in parallel to form a group of solar cells. For example, diagonally adjacent subapertures #5, #6, #7, and #8 form one group and diagonally adjacent subapertures #1, #2, #3, and #4 form another group. Such grouping of solar cells can be referred to as a “zig-zag” pattern of grouping solar cells. The zig-zag pattern can be especially effective when there are pure horizontal or pure vertical shadows present as the illuminated areas are the same for each series. When a 45 degree diagonal shadow is present, the zig-zag scheme can also be especially effective because the shadow clips across a diagonal of an even number so sub-apertures. Nevertheless, the zig-zag wiring scheme is a preferred wiring scheme for any shadow pattern as compared to other static arrangements.

[0092] When considering the entire solar panel array, such a series-parallel circuit, in isolation, may not produce a desirably high enough output voltage and/or may produce output currents which are undesirably high (requiring, for example, expensive thick wiring, fuses, electrical interconnects and so on). Thus, in order to produce a desired high-enough output voltage, and in order to help keep total current down to a desired low-enough level, it may not always be possible to wire as many solar cells in parallel as would be desired for good shadowing tolerance. The present invention therefore teaches a technique of further organizing subapertures into a larger number of parallel subcircuits comprising a smaller number of solar cells each. The preferred organization of

solar cells/subapertures into parallel subcircuits depends on the sort of shadows expected. For typical linear and rectangular shadow shapes expected in many situations, one appropriate organization of subapertures/solar cells into subcircuits is a repeating grid. The simplest form of such a grid is for the case of square subapertures and two parallel circuits, in which case the grid is simply a checkerboard pattern, as shown in FIGS. 11A and 11B. This two-circuit/square subaperture pattern was the exemplary solution disclosed in co-pending application No. 61/131,178, filed Jun. 6, 2008, entitled CONCENTRATING PHOTOVOLTAIC SOLAR PANEL, by Turk et al. (Attorney Docket Number: SE10033/P2), wherein said provisional patent application is incorporated herein by reference for all purposes.

[0093] Unusual shadow shapes can still result in poorly matched currents in the two parallel circuits of such a design, but typical shadow shapes are well mitigated. Nonetheless, the present invention teaches that current matching will be generally improved as the subaperture size is reduced because reducing the subaperture size tends to reduce the current contribution from any single subaperture. For shadows of reasonable shape, therefore, the total amount of current mismatch can be reduced by smaller subapertures. This is shown in FIGS. 14A and 14B, which illustrate two two-circuit/square subaperture designs, one with aperture 62 comprising subapertures 64 of dimension $2x$ and the other with aperture 92 comprising subapertures 94 of dimension x . As a rectangular shadow (not shown) creeps in from the corner, the worst-case current imbalance in the two parallel circuits is equal to the photocurrent produced by a single subaperture, and is therefore 4 times smaller for the system of FIG. 14B with subaperture dimension x than for that of FIG. 14A with subaperture dimension $2x$, thus resulting in $\frac{1}{4}$ as much worst case power loss due to the rectangular shadow for the case of FIG. 14B.

[0094] The present invention includes approaches for dealing with more than two parallel subcircuits (e.g. 66 or 68) in series (such as if a higher output voltage were desired) or for dealing with other than square subapertures. In the case of more than two parallel subcircuits, the subapertures (e.g. 94) corresponding to each subcircuit can be distributed relatively uniformly across the larger aperture (e.g. 92). For example, if three parallel subcircuits 96, 97, and 98 in series are desired, as shown in FIG. 15A, then a layout such as shown in FIG. 15B might be appropriate. Typical easily implemented approaches will tend to be repeating tiles of subapertures; in the example of FIG. 15B, the layout is comprised of the repeating tile shown in FIG. 15C. FIG. 15D shows how the full aperture is constructed from the tiles—the tiles are interlocked, and then truncated at the edges, just as would be done in laying out actual ceramic tiles for a countertop, for example. In such a case, note that the full aperture such as in FIG. 15B preferably has a number of subapertures that is a multiple of the repeating tile, so that the total number of each type of individual subaperture is the same. For example, the portion labeled A1 in FIG. 15D is made up of the subapertures numbered “3” and “1” in the repeating tile shown in FIG. 15C. And the portion labeled A2 in FIG. 15D is made up of the subaperture numbered “2” in the repeating tile shown in FIG. 15C. The sum of A1 and A2 correspond to a one repeating tile shown in FIG. 15C. Likewise, with reference to FIG. 15D, the sum of the portions labeled B1 and B2 and the sum of the portions labeled C1 and C2 each correspond to one repeating tile shown in FIG. 15C.

[0095] The present invention appreciates that it is not necessary even for the subapertures to be the same size, and any layout of subapertures will do as long as the total collecting area associated with each parallel subcircuit is approximately the same.

[0096] Likewise, the full aperture can comprise more than one sort of repeating tile, and tiles can be broken into pieces and placed in other places. Again, the analogy to a ceramic tile countertop is appropriate, wherein preferred embodiments can make use of whole numbers of tiles. That is, even if a tile must be cut into pieces to fill out the subaperture, it still represents a preferred embodiment if there are no fractional tiles left over.

[0097] By way of example, the subaperture pattern of FIG. 16A seems somewhat random at first appearance, but it is actually comprised of two basic tile types, the tiles of FIGS. 16B and 16C. Note that, as is preferred, each of the tiles allocates equal areas to subapertures of type #1, #2, and #3, in order to maintain approximately equal currents in each of the three associated parallel solar cell circuits. That is, with respect to the repeating tile shown in FIG. 16B, the area of the subaperture labeled #1 equals the sum of areas for the two subapertures labeled #2, and the area of the subaperture labeled #1 equals the area of the subaperture labeled #3. Likewise, with respect to the repeating tile shown in FIG. 16C, the sum of the areas for the two subapertures labeled #1 equals the sum of the areas for the three subapertures labeled #2, and the sum of the areas for the two subapertures labeled #1 equals the sum of the areas for the two subapertures labeled #3.

[0098] FIG. 16D shows how the aperture of FIG. 16A is assembled from the tiles shown in FIGS. 16B and 16C. Tiles 100 are of the type of FIG. 16B, while tile 102 is of the type of FIG. 16C. FIG. 16D also shows how a single tile can be cut into pieces and reassembled; a missing portion 104 of tile 106 has been cut off and is placed as tile fragment 108; further, the tile fragment 108 was placed upside down as compared to the orientation of the missing portion 104. All of these techniques, as well as any others that make use of whole numbers of tiles, represent preferred embodiments of the present invention.

[0099] FIG. 17A shows yet another type of repeating tile that embodies a three-parallel circuit design. FIG. 17B shows an aperture that is constructed from full and fragmented versions of the repeating tile shown in FIG. 17A. Note that there are many alternative embodiments of apertures that can be constructed from this tile that do not result in equal total areas of each subaperture; in the case shown, care has been taken, as shown in FIG. 17C, to construct a full aperture of appropriate proportions such that there are no tile fragments left over. Thus the two tile fragments labeled "A" may together form a single repeating tile shown in FIG. 17A, and likewise for the tile fragments labeled "B" and "C"; no tile fragments are left over, and thus this represents a preferred embodiment.

[0100] The present invention further appreciates that the tiles, subapertures, and apertures need not be restricted to just squares and rectangles; any shape is acceptable as long as the basic principles of equal areas of subaperture are devoted to each parallel circuit.

[0101] For example, FIG. 18A illustrates subapertures corresponding to four parallel subcircuits wired in series, said subapertures including both rectangular and triangular subapertures. FIG. 18A has a repeating grid which refers to the relative amount of symmetry in the grid. FIG. 18A shows a

rotationally symmetric pattern. And while a repeating grid is an obvious straightforward approach, it is not required, as shown in FIG. 18B, another sample embodiment. FIG. 18B shows a grid having a left-right symmetry but not a top-bottom nor rotational symmetry. FIG. 18B also illustrates that, while it is preferred to generally "stagger" the subapertures, i.e., to create maximum homogeneity across the aperture, alternative embodiments such as FIG. 18B may have less homogeneity.

[0102] Finally, FIG. 18C illustrates that apertures and/or subaperture tiles need not be rectangular, but may be any shape. In preferred embodiments, subaperture tiles tessellate (i.e., fill a 2D space using a shape that is translated and/or rotated, and tiled with other shapes) so that the aperture area is completely filled, but it is not required to completely fill the aperture area; portions of the aperture area may be left unused.

[0103] Additionally, although the embodiments shown in the figures mostly contemplate generally rectangular apertures, the apertures may be of any desired shape. In summary, then, the invention teaches the following preferred technique for organizing solar cells into circuits: 1) Identify subaperture groups within the aperture(s) of the photovoltaic submodule, with each subaperture group having a total subaperture area that is approximately equal to the area of each of the other subaperture groups. Preferably, the subaperture groups should be distributed homogeneously across the aperture. 2) Collect the solar cells from each of these groups together into parallel-wired sub-circuits 3) Wire the parallel sub-circuits in series. 4) Wire these parallel-series assemblies in series with other similarly shadowed assemblies from other apertures. As mentioned above, this preferred technique can be extrapolated to apply among multiple solar and/or among multiple solar modules.

[0104] A further alternative is to allow subaperture groups to span multiple apertures. That is, in the embodiments described up to this point, it has been generally assumed that the solar cells within an aperture form a single series-parallel group, with a single input and output wire from the group; this basic topology is illustrated in a preferred embodiment FIG. 19A where each collector 101 of solar panel 105 is wired in series with one or more adjacent collectors 101. FIG. 19B shows the entire solar panel 105 in further detail, revealing the series-parallel combination of the eight subapertures present in each collector 101 within the module 105.

[0105] However, the concept of combining subapertures, or groups of subapertures (for example, series-parallel combinations of subapertures) into series-parallel combinations can extend beyond an individual collector. For example, FIG. 19C illustrates an alternative wiring embodiment for a concentrating photovoltaic module 110 whose collectors 111 are wired into two parallel strings which are combined only at the ends of the module 110. As shown in FIG. 19D, the subapertures within each collector may also be wired together in series-parallel combinations. Alternatively, not shown, each collector may be wired individually into series strings. FIG. 19E shows yet another alternative series-parallel combination of individual collectors that is possible for module 115.

[0106] In short, the present invention allows that any series-parallel combination of subapertures throughout the photovoltaic submodule may be used, with preference given towards those series-parallel wiring combinations that provide maximum shade tolerance by tending to equalize the available photocurrents (i.e., the total currents of parallel sets

of cells are the same) in any subapertures or groups of subapertures that are wired in series.

[0107] FIG. 19F shows an example of how the present invention can be extrapolated to apply to multiple . 207 are grouped together and wired in parallel such that the total current for a given group is substantially similar to all of the other groups of 207 wired in parallel. As shown, each submodule 207 has eight subapertures (numbered 1-8) similar to each submodule 101 shown in FIG. 19A. The 207 can be from the same solar module or can be from two or more different solar modules.

What is claimed is:

1. A photovoltaic solar system, comprising a plurality of solar electrically coupled in series, wherein at least one of the solar has an aperture comprising a plurality of subapertures that independently focus incident light onto at least one solar cell, said solar cells of said subapertures are arranged in at least two groups of solar cells coupled in series, wherein each solar cell group comprises at least two solar cells electrically coupled in parallel.

2. The system of claim 1, wherein at least one of said solar cell groups comprises first and second solar cells electrically coupled in parallel, wherein the first and second solar cells are positioned diagonally adjacent each other.

3. The system of claim 1, wherein at least one of said solar cell groups comprises at least three solar cells electrically coupled in parallel, wherein each of said three solar cells is positioned at least diagonally adjacent to at least one of the other solar cells of said at least three solar cells.

4. The system of claim 1, wherein at least one of said solar cell groups comprises at least four solar cells electrically coupled in parallel, wherein each of said four solar cells is positioned at least diagonally adjacent to at least one of the other solar cells of said at least four solar cells.

5. The system of claim 1, wherein there is a one to one correspondence between each subaperture and each solar cell.

6. A solar, photovoltaic system comprising at least one photovoltaic submodule, wherein the at least one submodule comprises:

- a. a first group of photovoltaic cells comprising at least two photovoltaic cells wired in parallel;
- b. a second group of photovoltaic cells comprising at least two photovoltaic cells wired in parallel, wherein the at least two photovoltaic cells of the second group are different than the at least two photovoltaic cells of the first group, and wherein the first group and second group are wired in series.

7. The system of claim 6, wherein the first group of photovoltaic cells comprises four photovoltaic cells wired in parallel and the second group of photovoltaic cells comprises four photovoltaic cells wired in parallel.

8. The system of claim 6, wherein the system is a solar, photovoltaic concentrator system and wherein the are photovoltaic concentrator .

9. A solar system comprising a plurality of solar electrically coupled in series, wherein at least one solar submodule comprises a plurality of solar cells that independently capture incident light, wherein said at least one submodule comprises a first row of solar cells comprising at least first through fourth solar cells and a second row comprising at least fifth through eighth solar cells, wherein said solar cells exist in at least two groups coupled in series, wherein the first and second groups each comprises at least two solar cells from the first row and

at least two solar cells from the second row, wherein each of said at least two solar cells from the first row and each of said at least two solar cells from the second row are electrically coupled in parallel with each other.

10. The system of claim 9, wherein each group of solar cells comprises at least two solar cells that are diagonally adjacent to each other.

11. The system of claim 9, wherein the system is a solar concentrator system and the plurality of independently capture and concentrate incident light onto solar cells.

12. A photovoltaic solar system, comprising a plurality of solar modules electrically coupled in series, wherein at least one solar module comprises a plurality of solar that independently capture incident light, said solar arranged in at least two groups coupled in series, wherein each submodule group comprises at least two electrically coupled in parallel.

13. The system of claim 12, wherein at least one of the groups comprises first and second electrically coupled in parallel, wherein the first and second are positioned diagonally adjacent each other.

14. The system of claim 12, wherein said at least one group comprises at least three electrically coupled in parallel, wherein each of said three is positioned at least diagonally adjacent to at least one of the other of said at least three .

15. The system of claim 12, wherein the system is a solar concentrator system and the plurality of independently capture and concentrate incident light onto a target.

16. A solar system comprising a plurality of solar electrically coupled in series, wherein at least one solar submodule comprises a plurality of targets that independently capture incident light, wherein said at least one submodule comprises a first row of targets comprising at least first through fourth targets and a second row comprising at least fifth through eighth targets, wherein said targets exist in at least two groups coupled in series, wherein the first and second groups each comprises at least two targets from the first row and at least two targets from the second row, wherein each of said at least two targets from the first row and each of said at least two targets from the second row are electrically coupled in parallel with each other.

17. The system of claim 16, wherein the system is a solar concentrator system and the plurality of independently capture and concentrate incident light onto targets.

18. A solar concentrator system, comprising a plurality of solar concentrator modules electrically coupled in series, wherein at least one module comprises first and second electrically coupled groups, each group comprising a plurality of electrically coupled to each other in parallel, wherein each submodule within each group is structurally positioned within a module such that each submodule is diagonally adjacent to at least one other submodule of the group.

19. A method of making a solar system comprising the steps of:

- a) providing a plurality of solar modules, wherein at least one solar module comprises a plurality of solar , wherein each submodule has an aperture comprising a plurality of subapertures, wherein each subaperture has an area that captures incident light and directs said light onto at least one solar cell;
- b) identifying two or more subaperture groups in a manner such that the sum of the subaperture areas within each group is substantially equal among the subaperture groups;

- c) electrically coupling the solar cells associated with a subaperture group in parallel; and
- d) electrically coupling the submodule groups in series.

20. The method of claim **19**, further comprising the step of electrically coupling the solar modules in series.

21. The method of claim **19**, further comprising the step of electrically coupling the solar modules in parallel.

22. A solar system comprising a plurality of solar modules, wherein at least one solar module comprises two or more submodule groups, wherein each submodule group comprises a plurality of solar , wherein each submodule has an aperture having an area that captures incident light, wherein the sum of the submodule aperture areas within each group is substantially equal among the submodule groups, wherein

the with a submodule group are electrically coupled in parallel, and wherein the submodule groups are electrically coupled in series.

23. The system of claim **22**, wherein the solar modules are electrically coupled in series.

24. The system of claim **22**, wherein the system is a solar concentrator system and each of the submodule apertures captures and concentrates incident light onto a target.

25. The system of claim **24**, wherein the target comprises one or more solar cells.

26. The system of claim **22**, wherein each submodule within each group is structurally positioned within a module such that each submodule is diagonally adjacent to at least one other submodule of the group.

* * * * *