



US 20100002823A1

(19) **United States**

(12) **Patent Application Publication**  
**Monkhorst et al.**

(10) **Pub. No.: US 2010/0002823 A1**

(43) **Pub. Date: Jan. 7, 2010**

(54) **CONTROLLED FUSION IN A FIELD  
REVERSED CONFIGURATION AND DIRECT  
ENERGY CONVERSION**

(60) Provisional application No. 60/277,374, filed on Mar. 19, 2001, provisional application No. 60/297,086, filed on Jun. 8, 2001.

(76) Inventors: **Hendrik J. Monkhorst,**  
Gainesville, FL (US); **Norman  
Rostoker,** Irvine, CA (US)

**Publication Classification**

(51) **Int. Cl.**  
**G21B 1/05** (2006.01)

(52) **U.S. Cl.** ..... **376/121**

(57) **ABSTRACT**

A system and apparatus for controlled fusion in a field reversed configuration (FRC) magnetic topology and conversion of fusion product energies directly to electric power. Preferably, plasma ions are magnetically confined in the FRC while plasma electrons are electrostatically confined in a deep energy well, created by tuning an externally applied magnetic field. In this configuration, ions and electrons may have adequate density and temperature so that upon collisions ions are fused together by the nuclear force, thus forming fusion products that emerge in the form of an annular beam. Energy is removed from the fusion product ions as they spiral past electrodes of an inverse cyclotron converter. Advantageously, the fusion fuel plasmas that can be used with the present confinement and energy conversion system include advanced (aneutronic) fuels.

Correspondence Address:

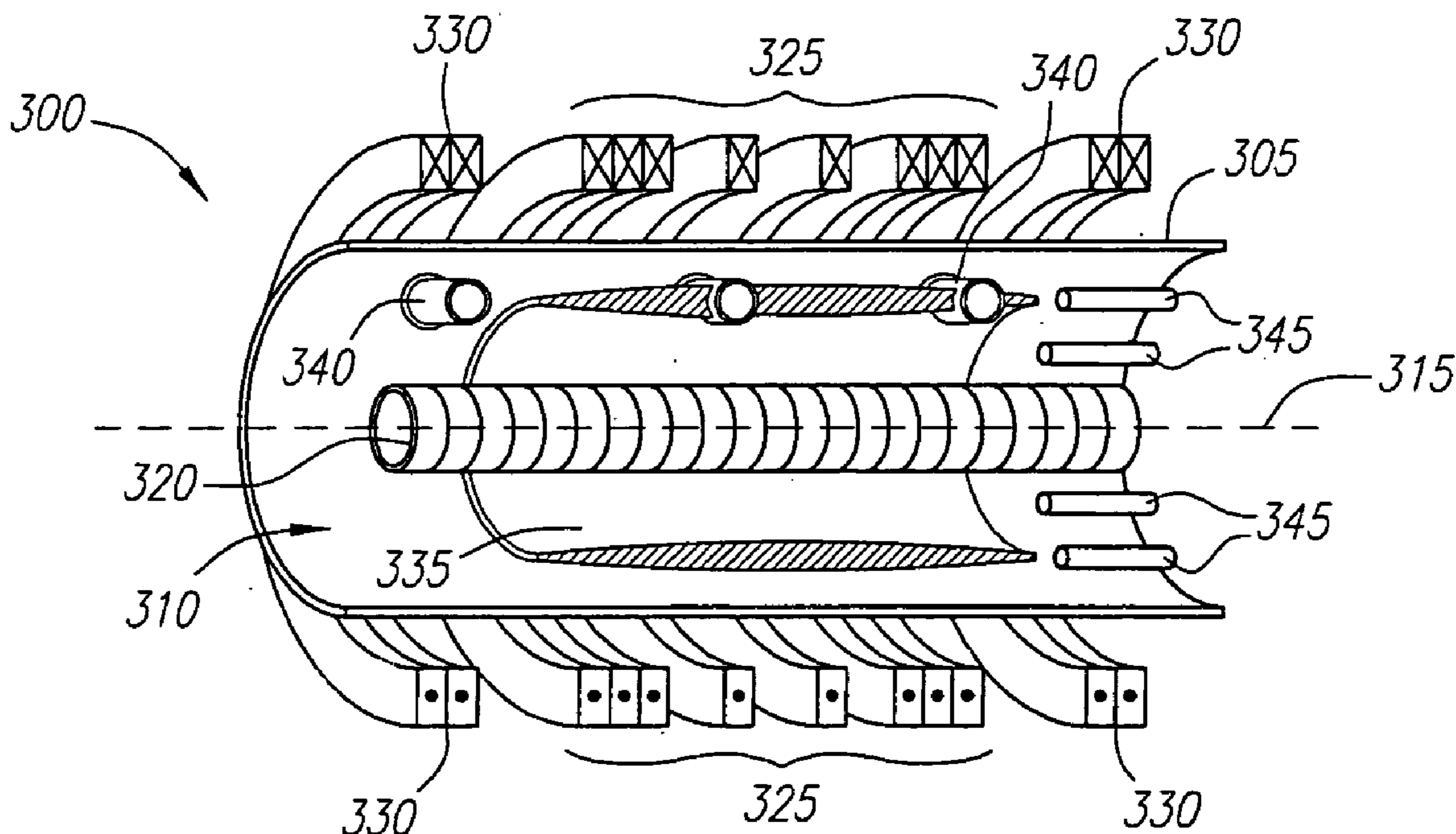
**ORRICK, HERRINGTON & SUTCLIFFE, LLP**  
**IP PROSECUTION DEPARTMENT**  
**4 PARK PLAZA, SUITE 1600**  
**IRVINE, CA 92614-2558 (US)**

(21) Appl. No.: **12/380,012**

(22) Filed: **Feb. 20, 2009**

**Related U.S. Application Data**

(60) Continuation of application No. 10/982,515, filed on Nov. 5, 2004, now abandoned, which is a division of application No. 10/410,830, filed on Apr. 9, 2003, now Pat. No. 6,850,011, which is a continuation of application No. 10/076,793, filed on Feb. 14, 2002, now Pat. No. 6,611,106.



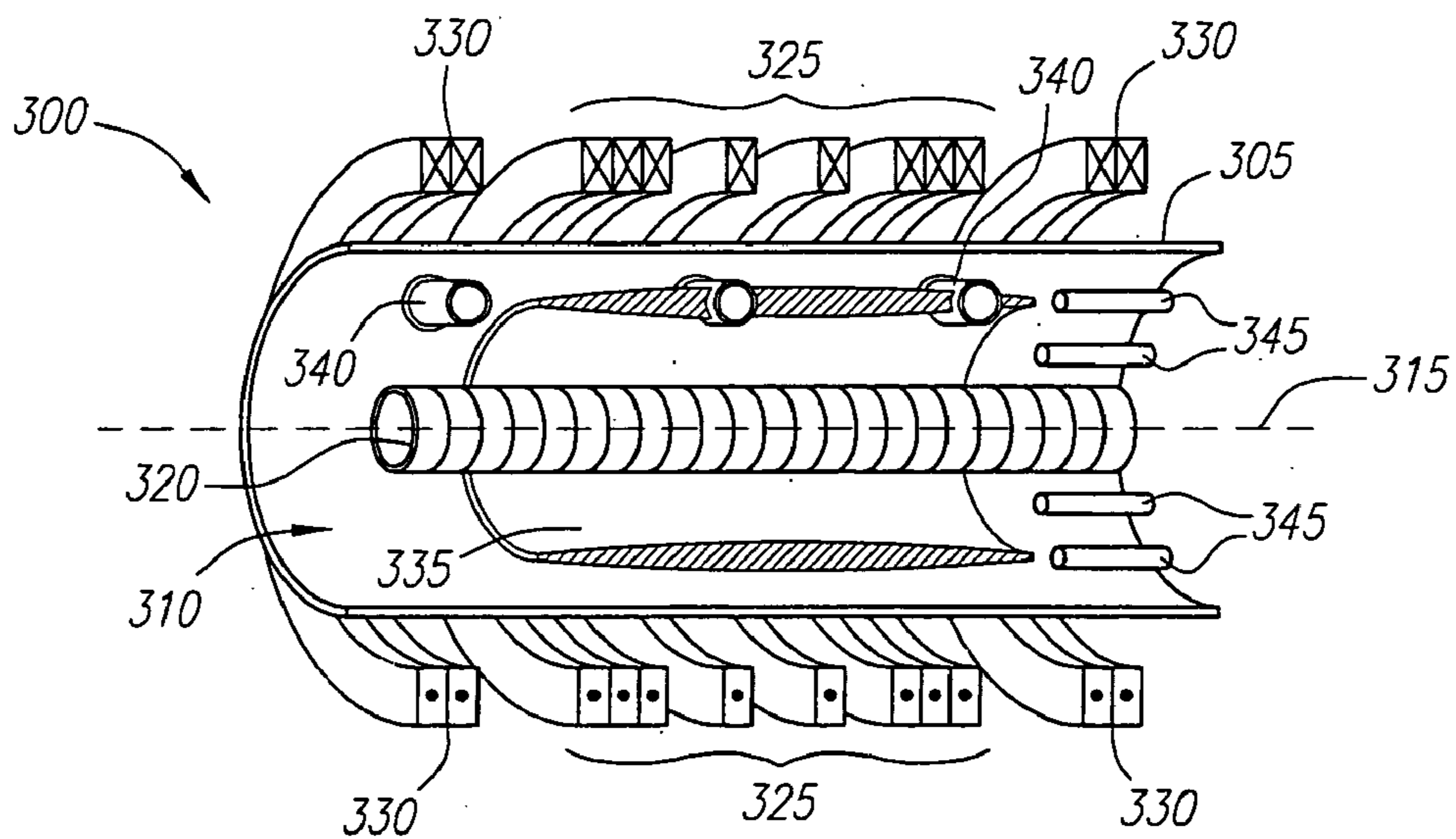


FIG. 1

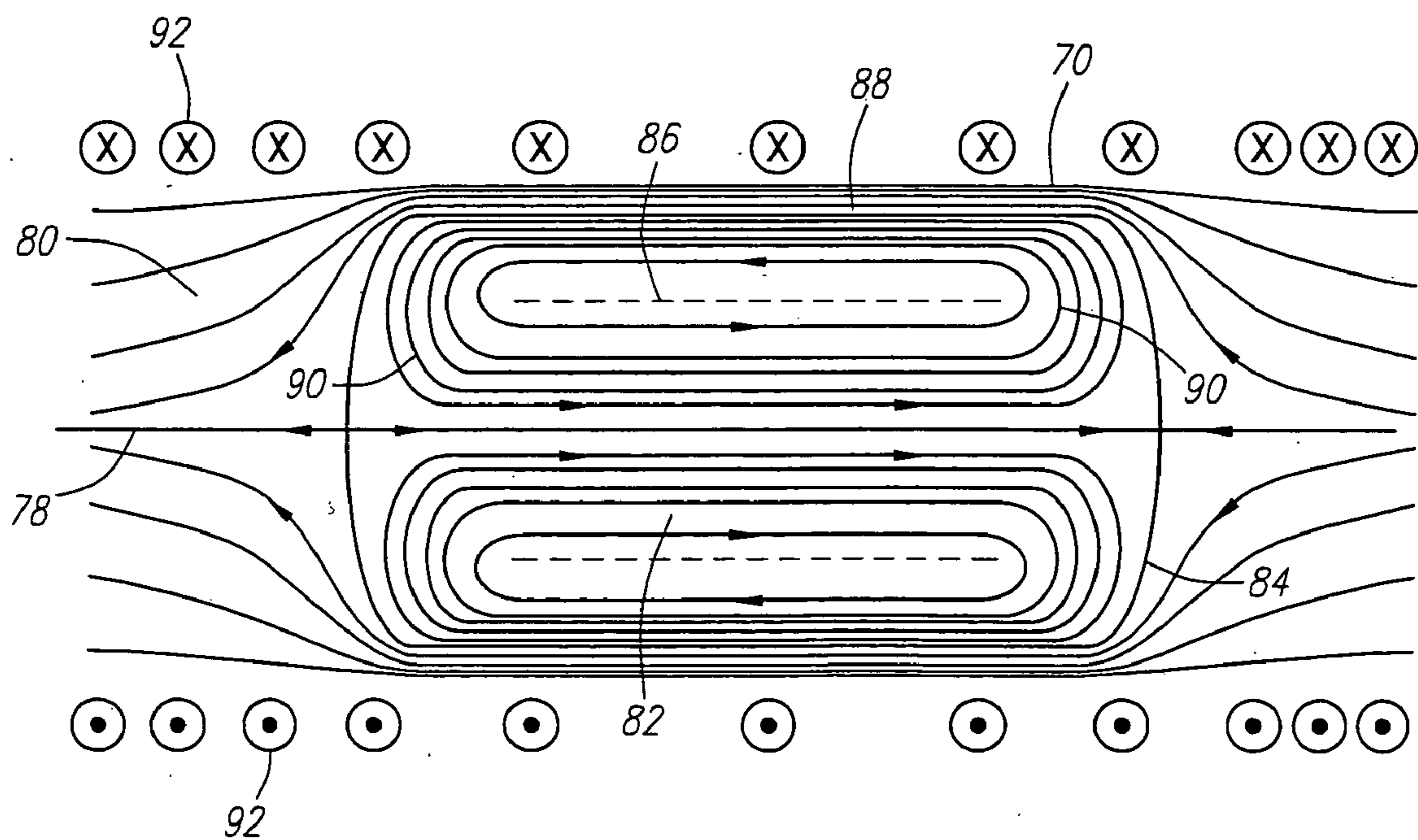
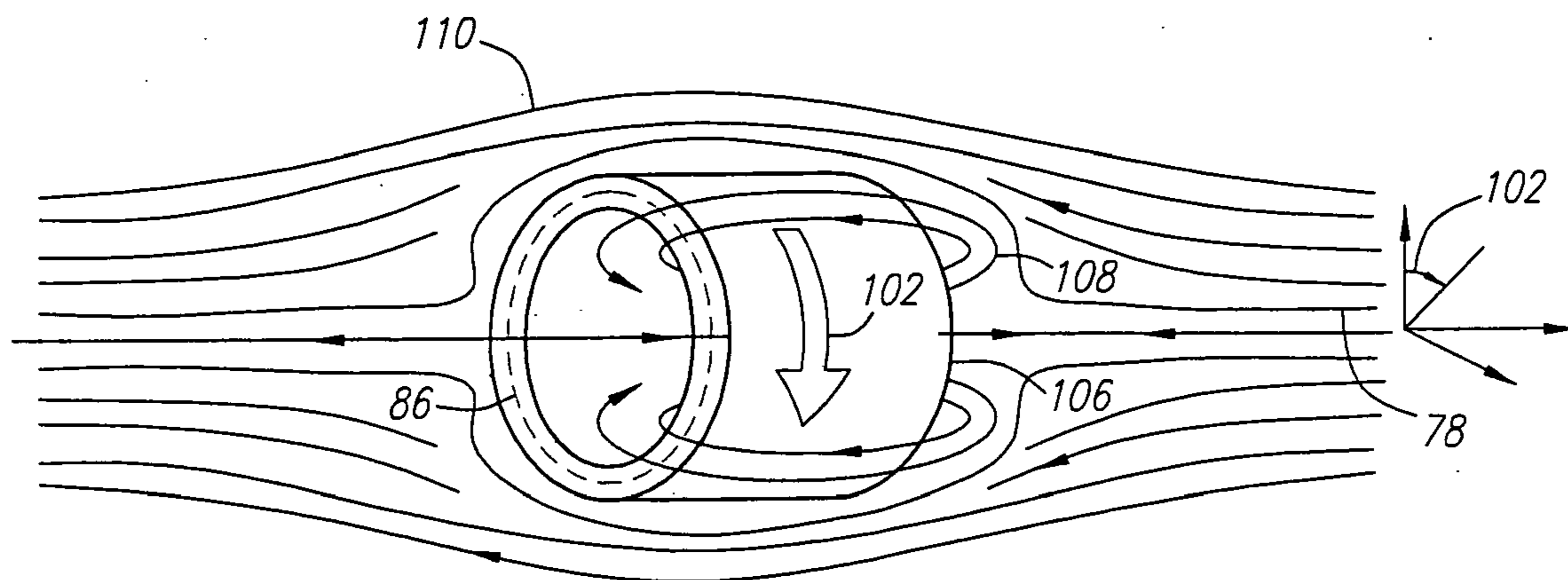
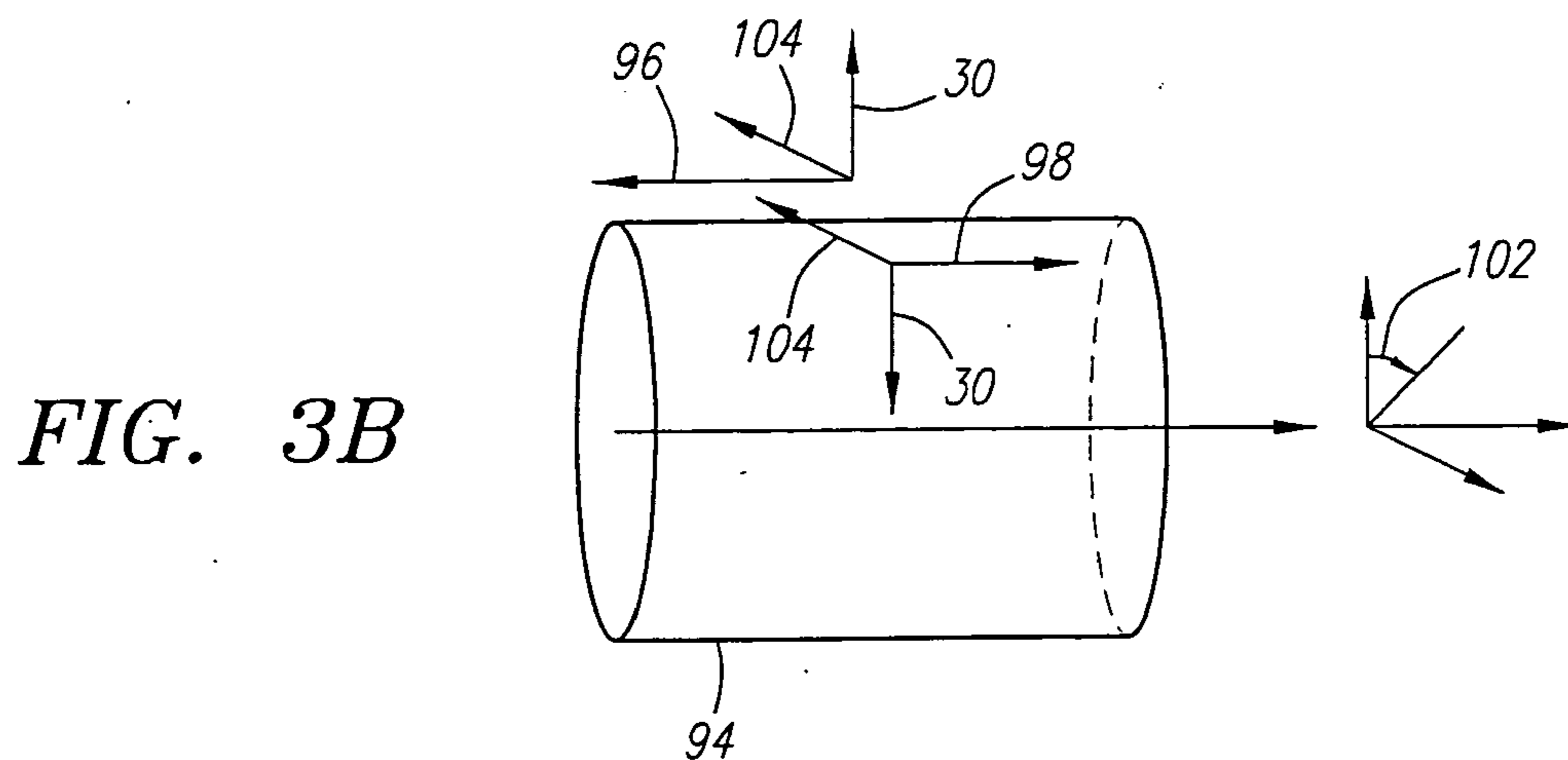
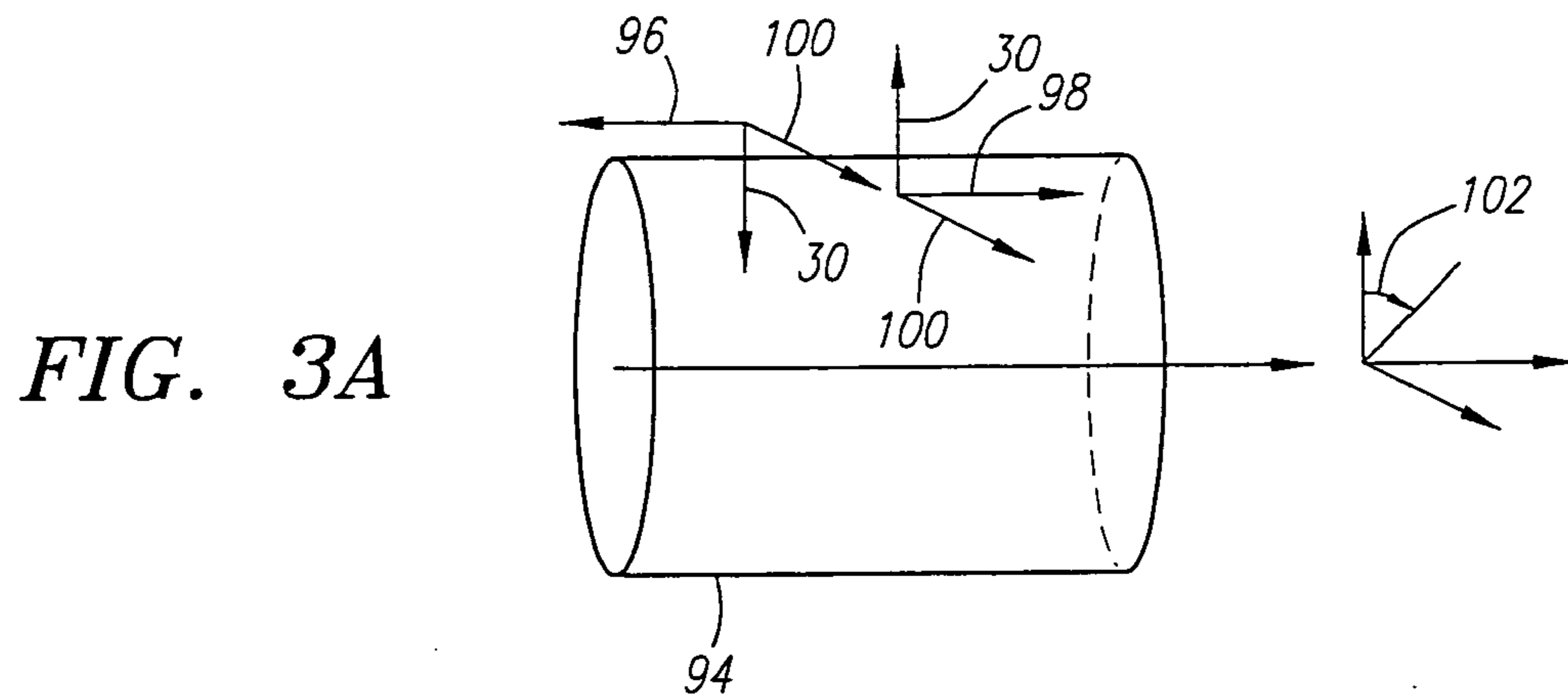
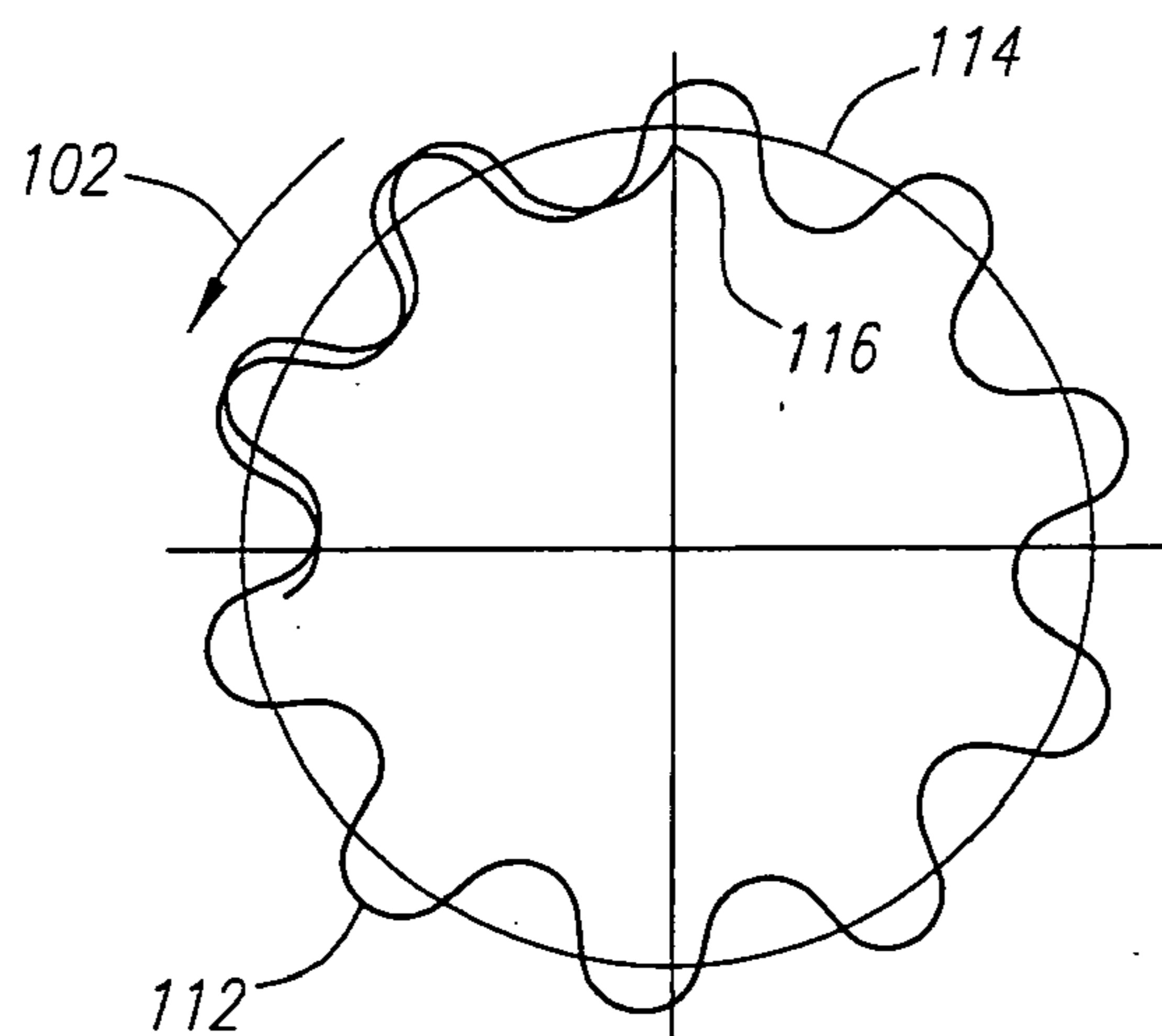


FIG. 2

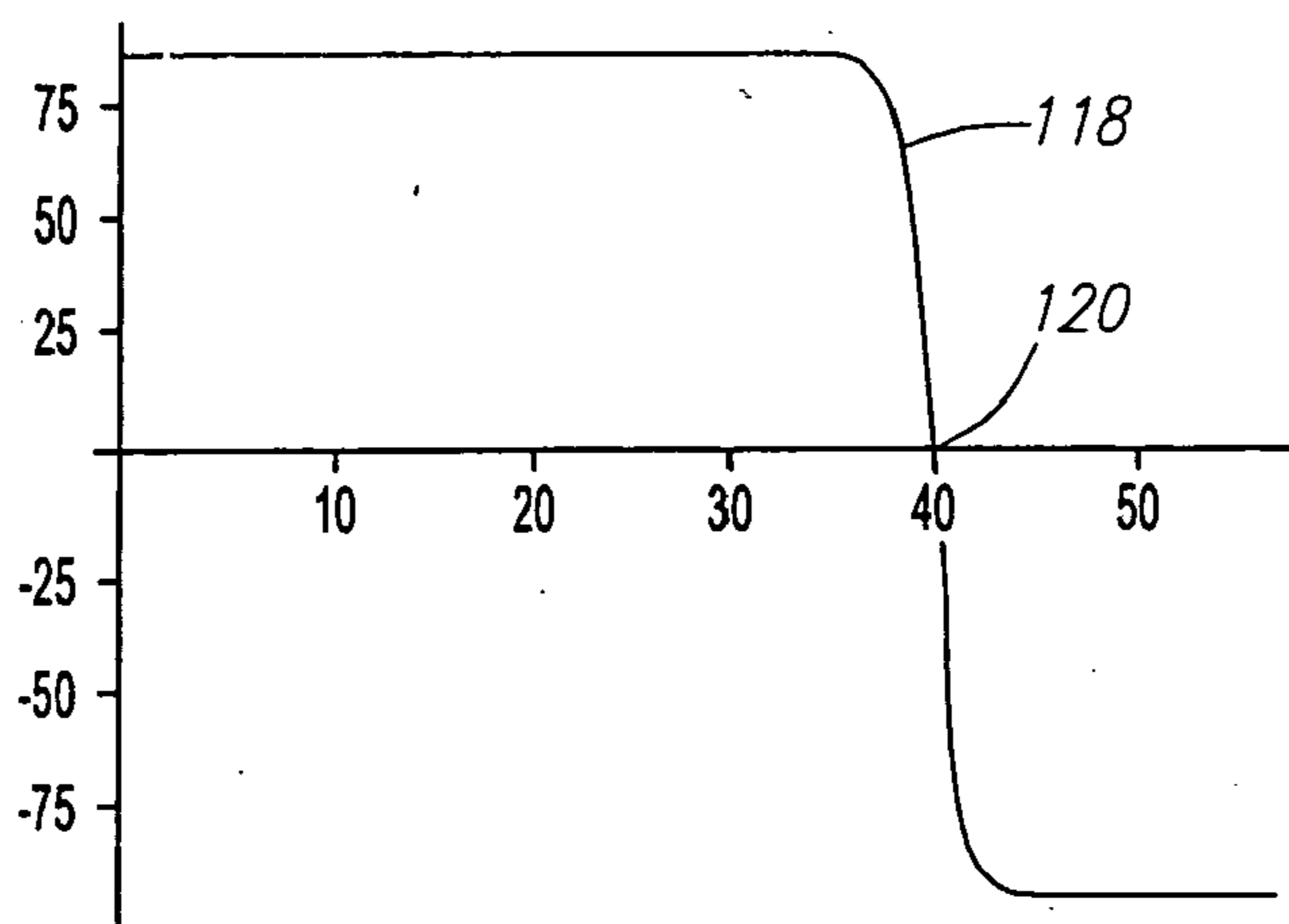
PRIOR ART



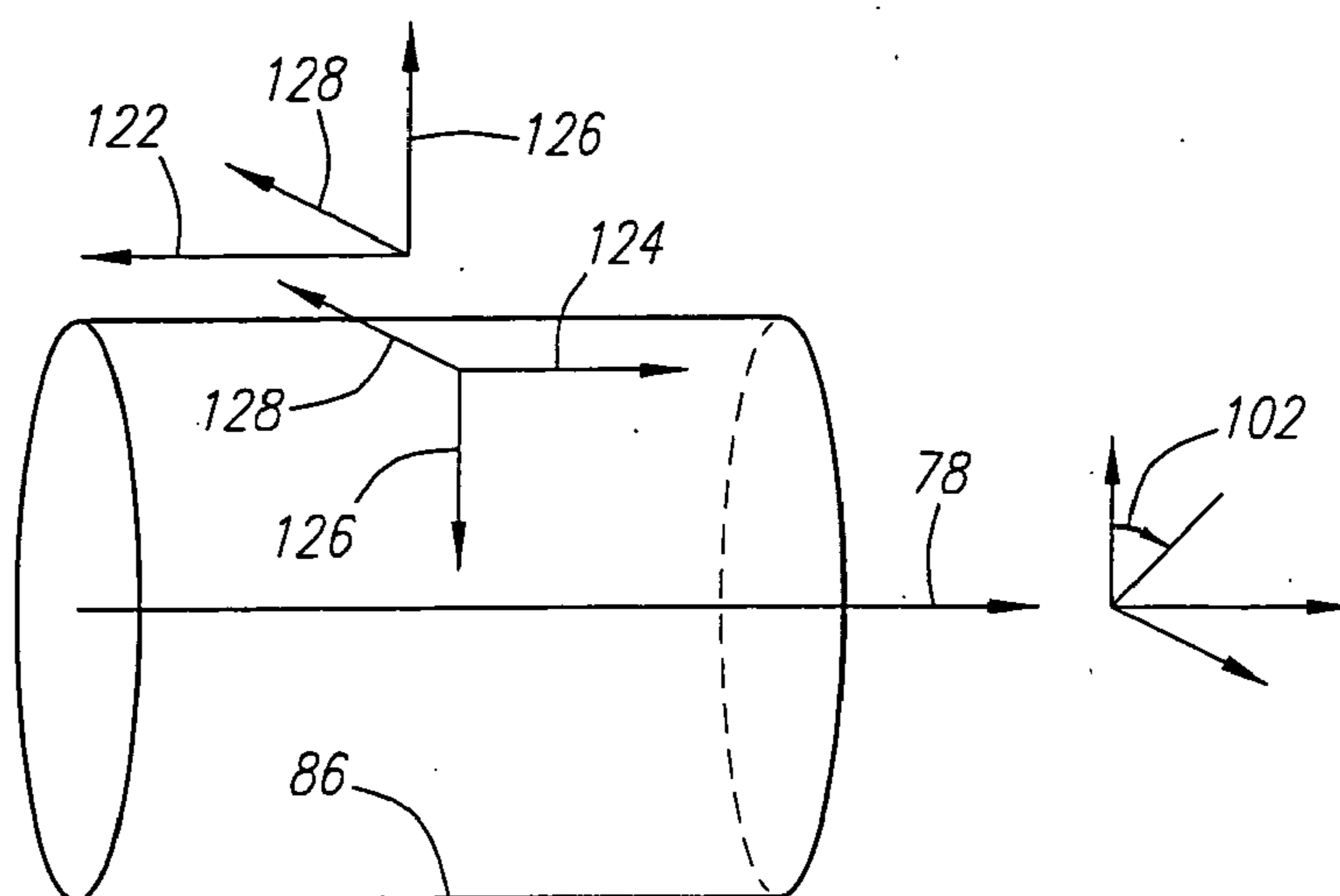


**FIG. 5**

PRIOR ART



**FIG. 6A**



**FIG. 6B**

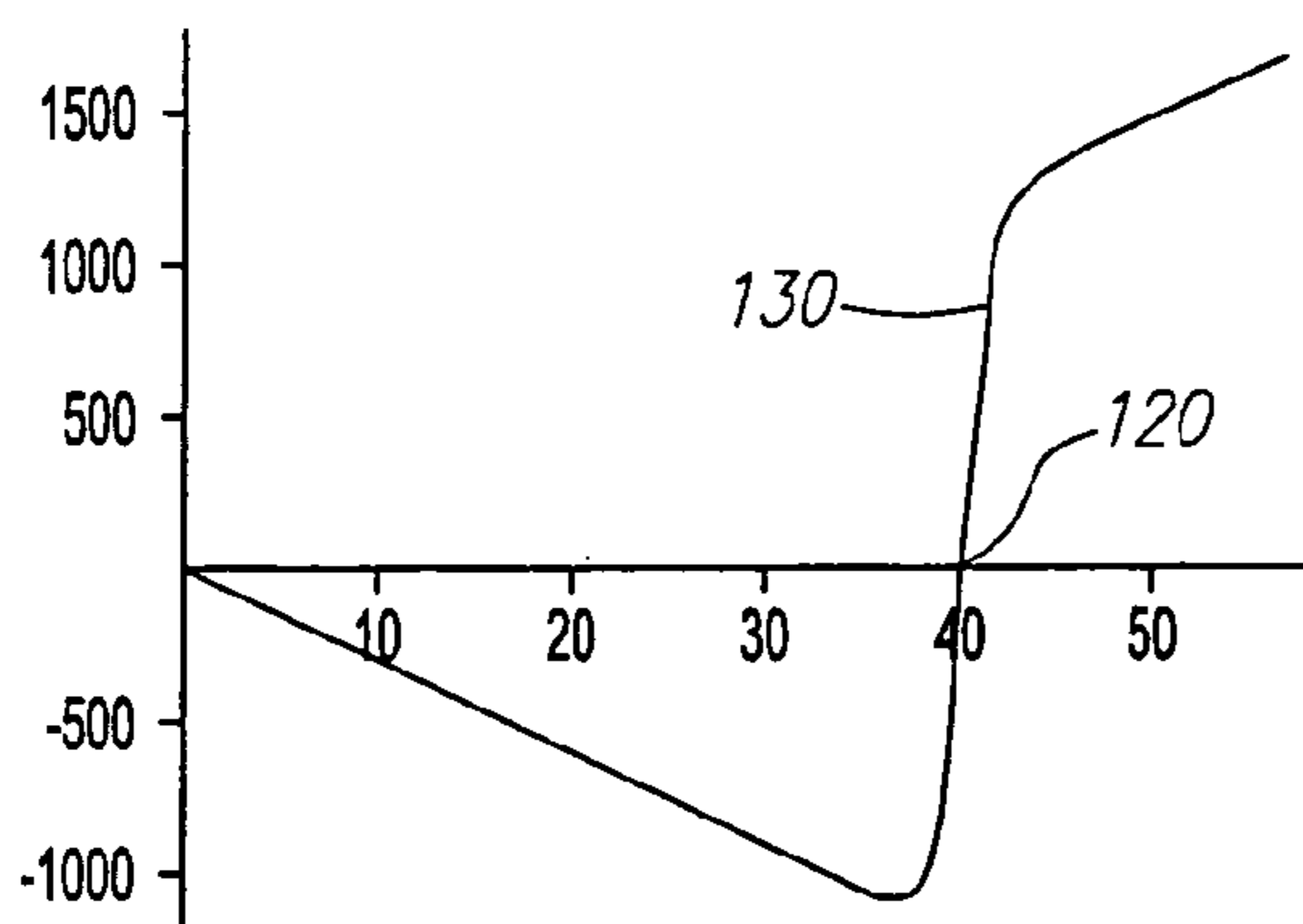


FIG. 7A

FIG. 7B

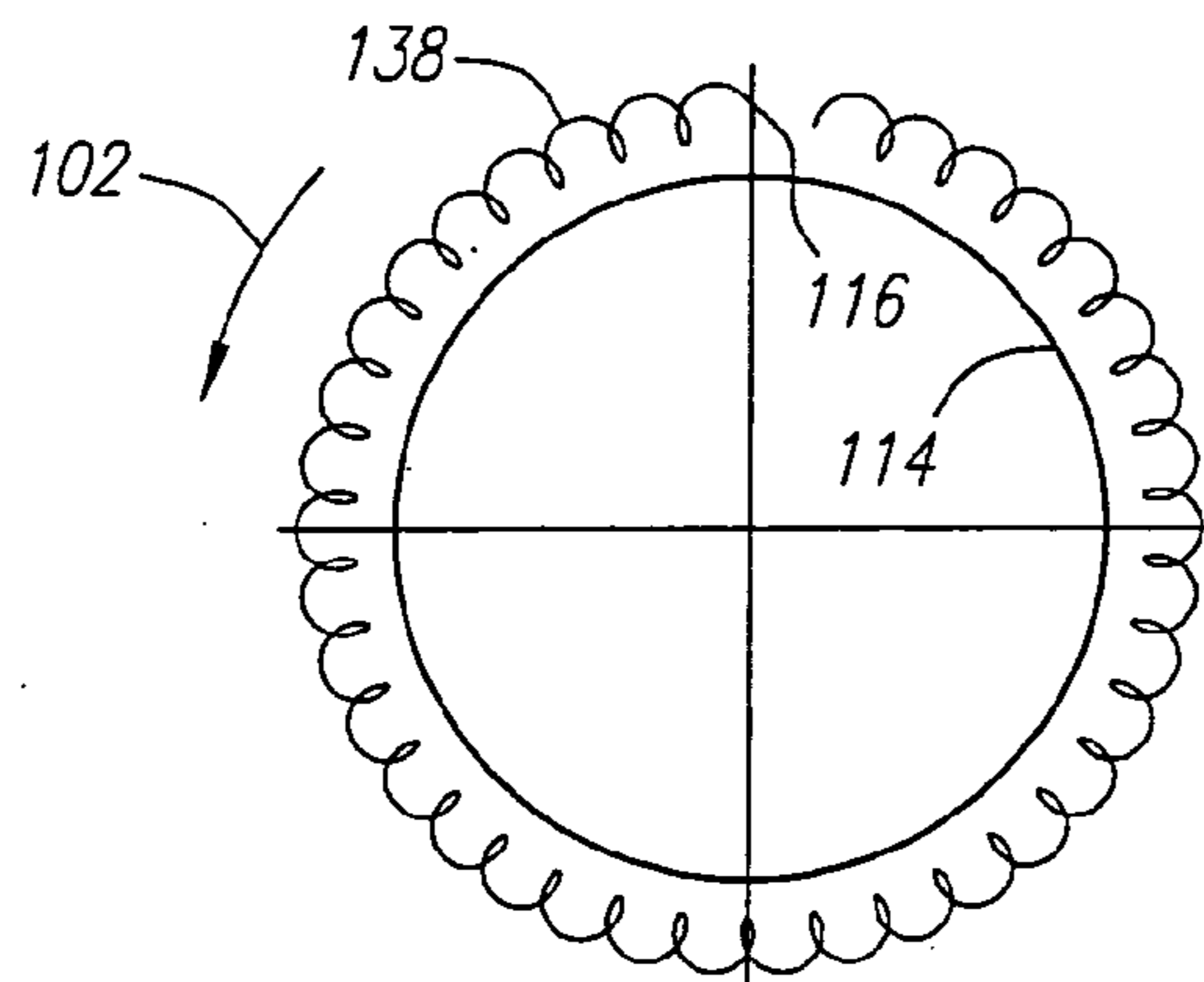
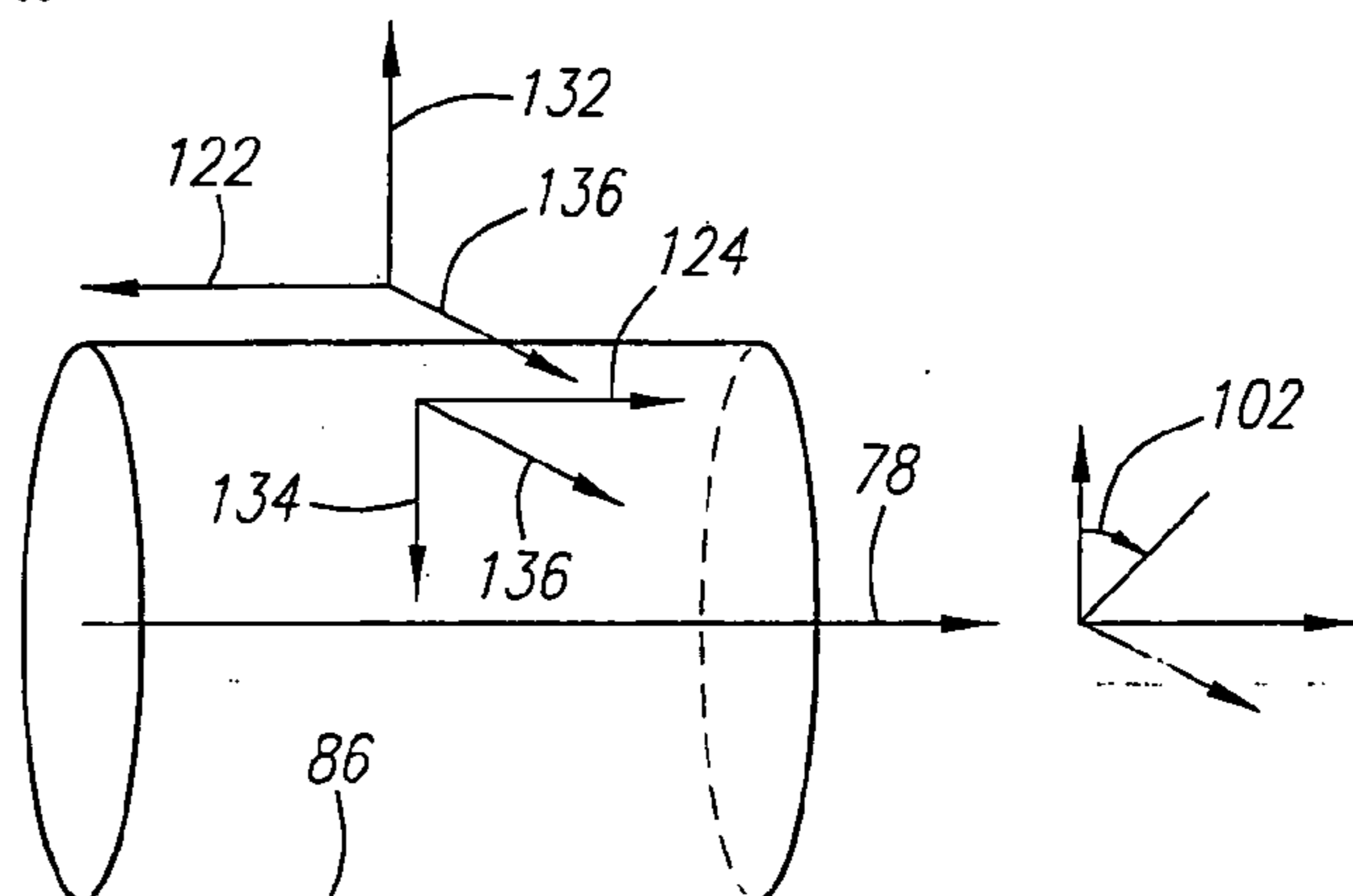


FIG. 8A

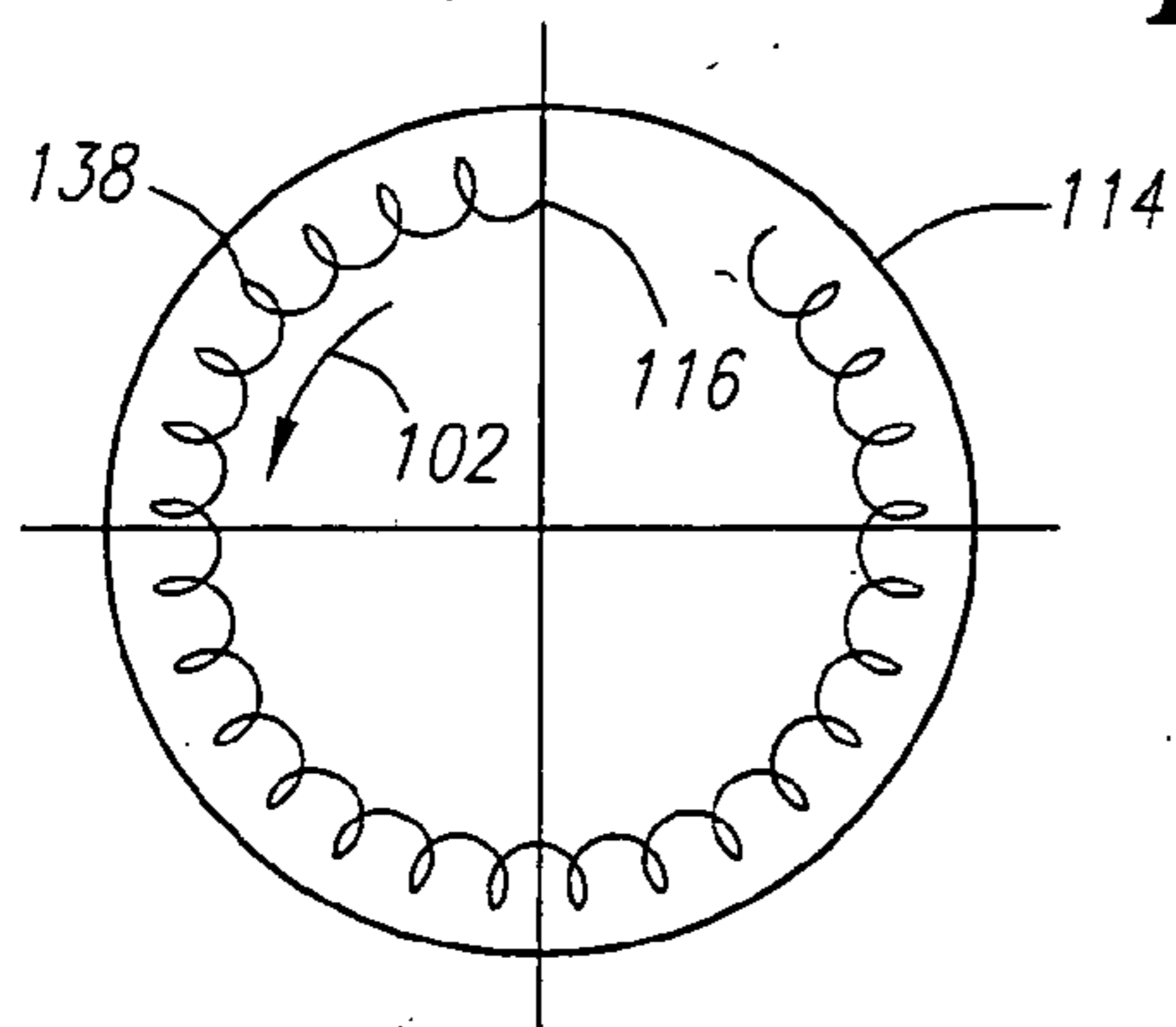


FIG. 8B

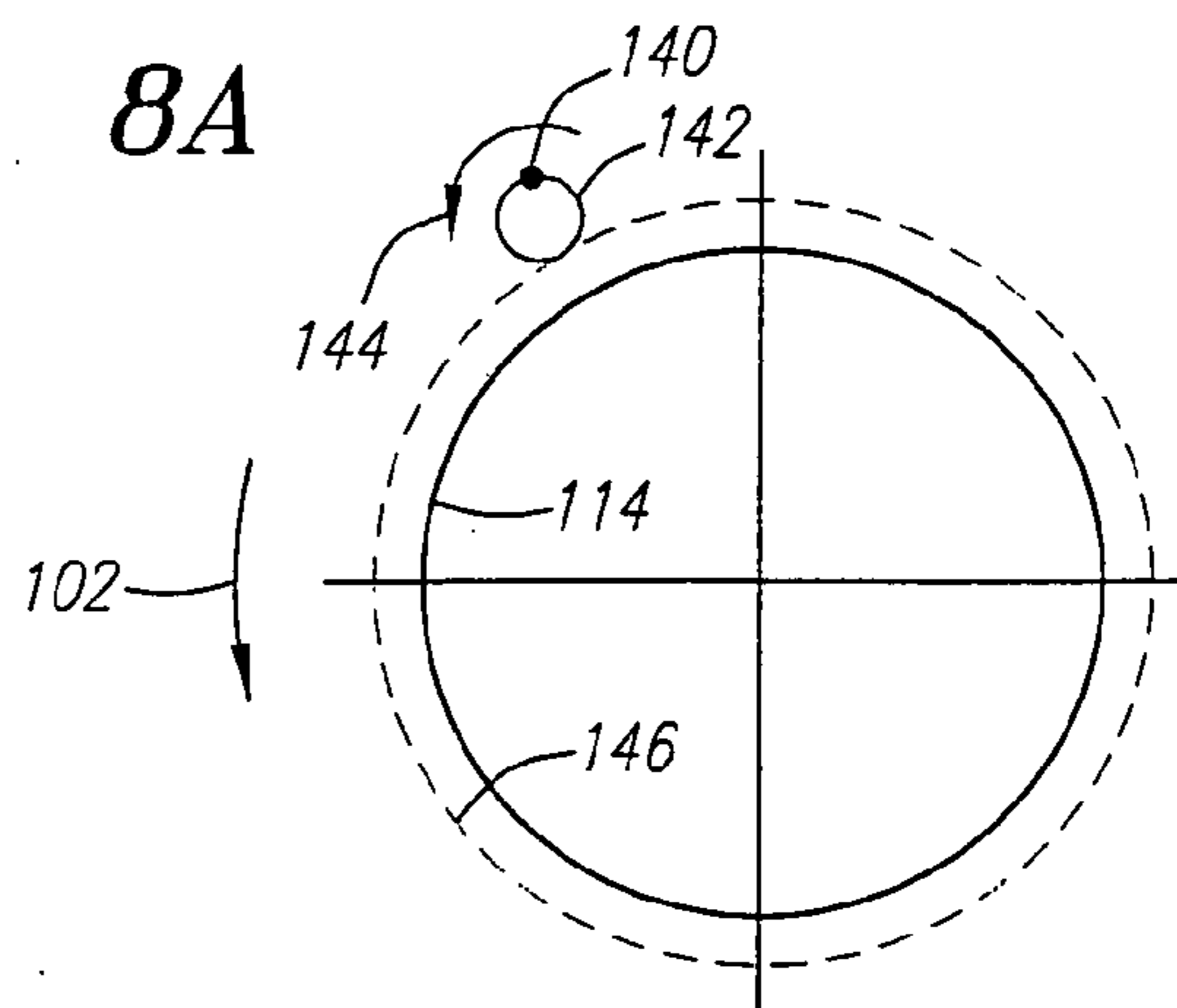


FIG. 8C

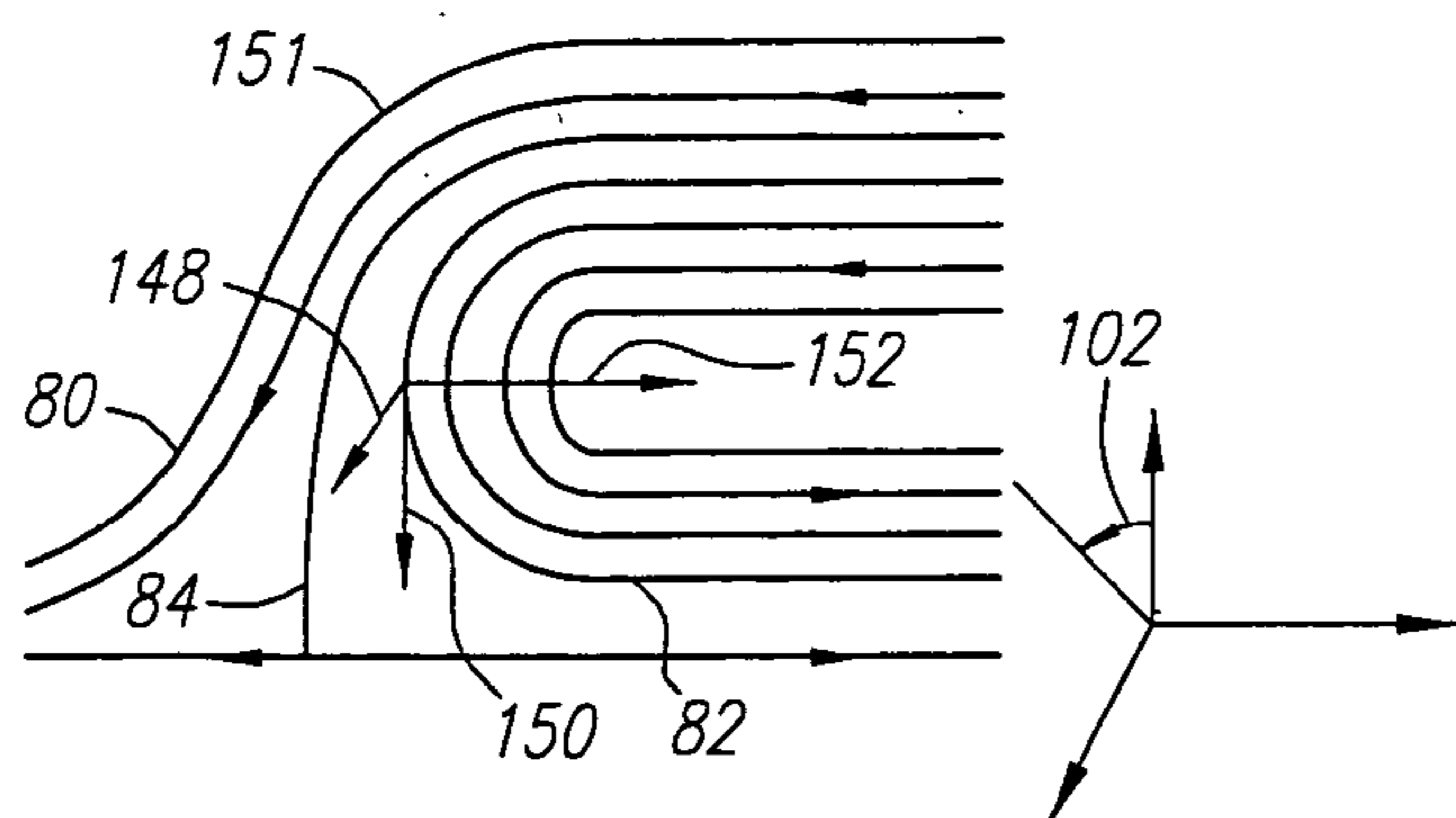


FIG. 9A

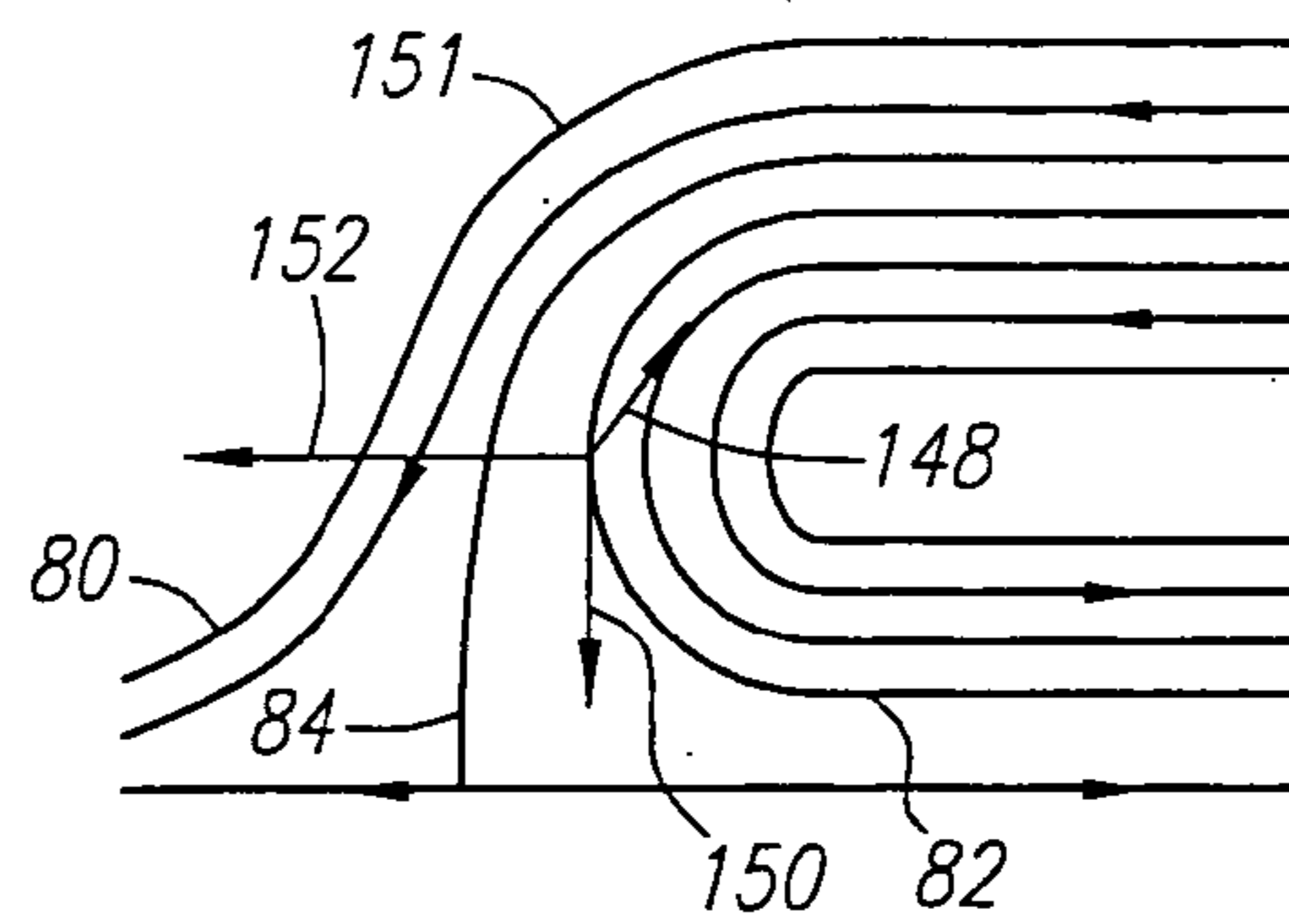


FIG. 9B

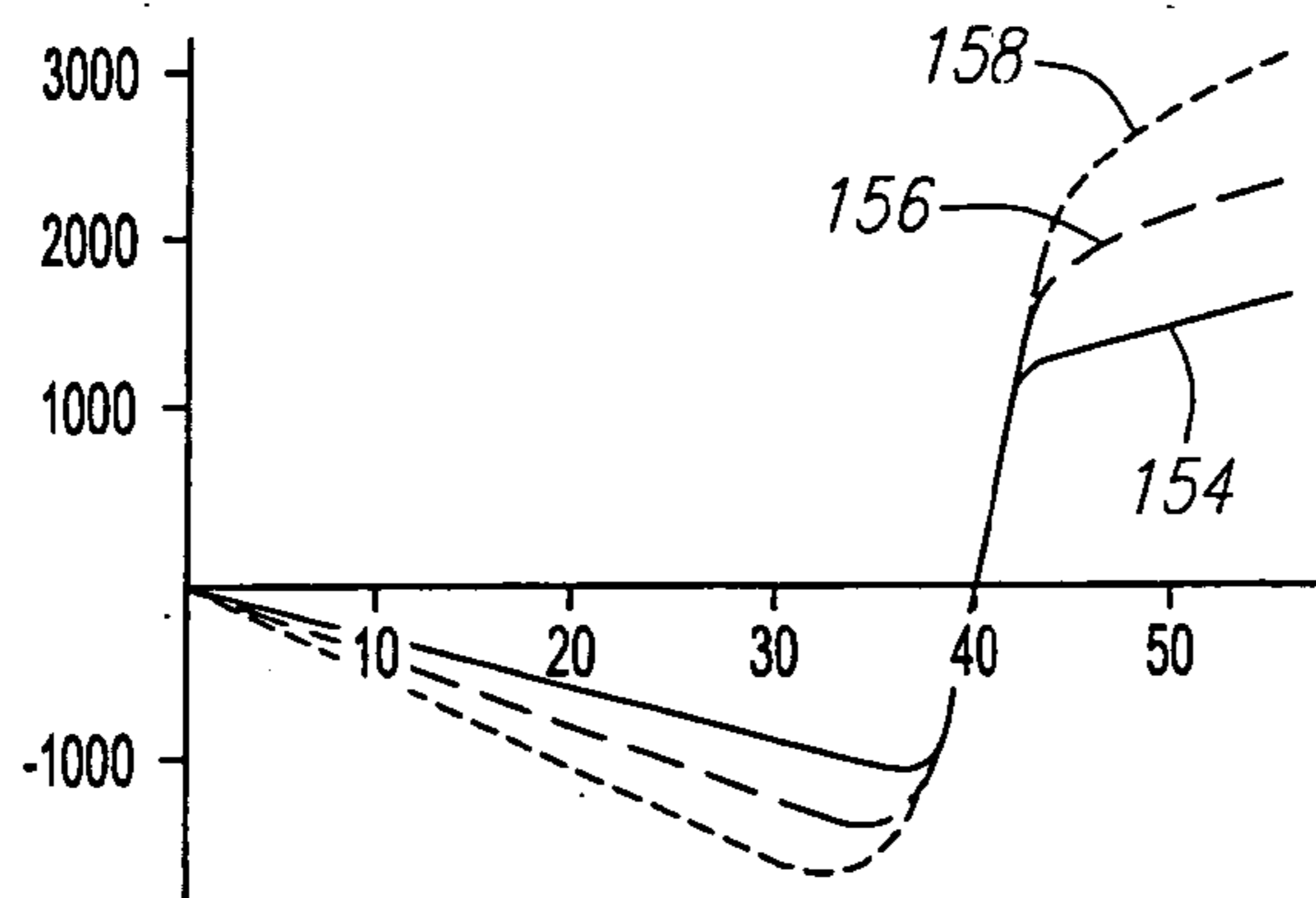


FIG. 10A

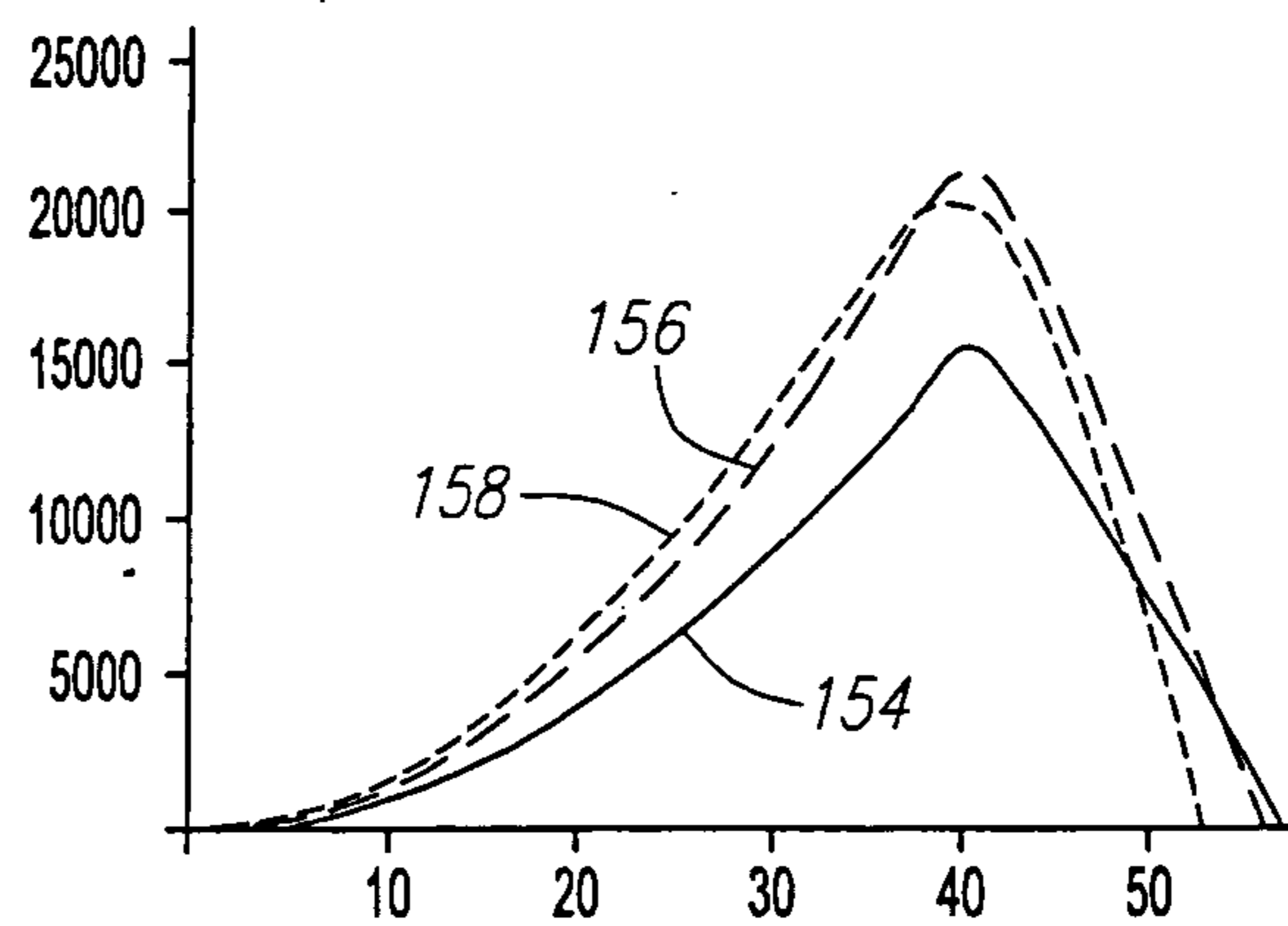


FIG. 10B

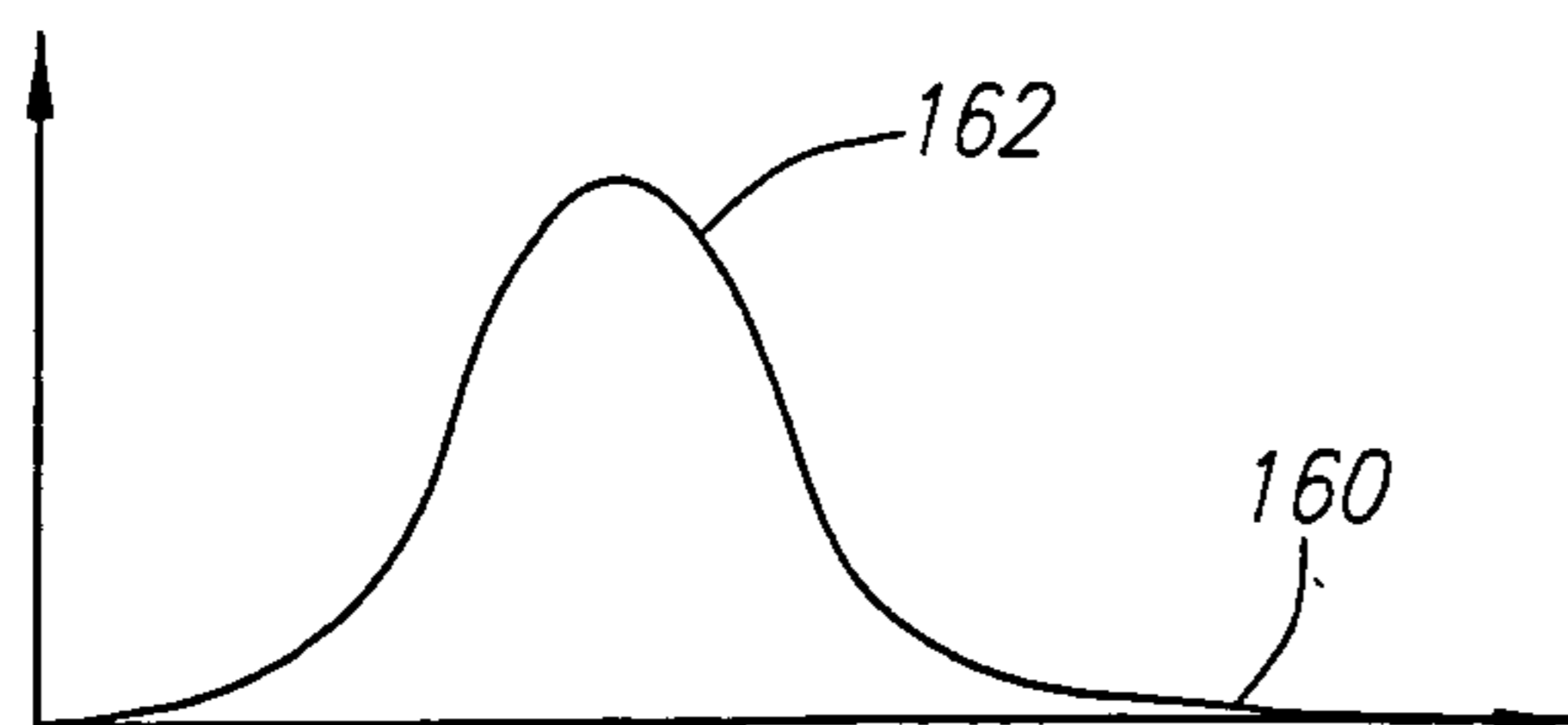


FIG. 11

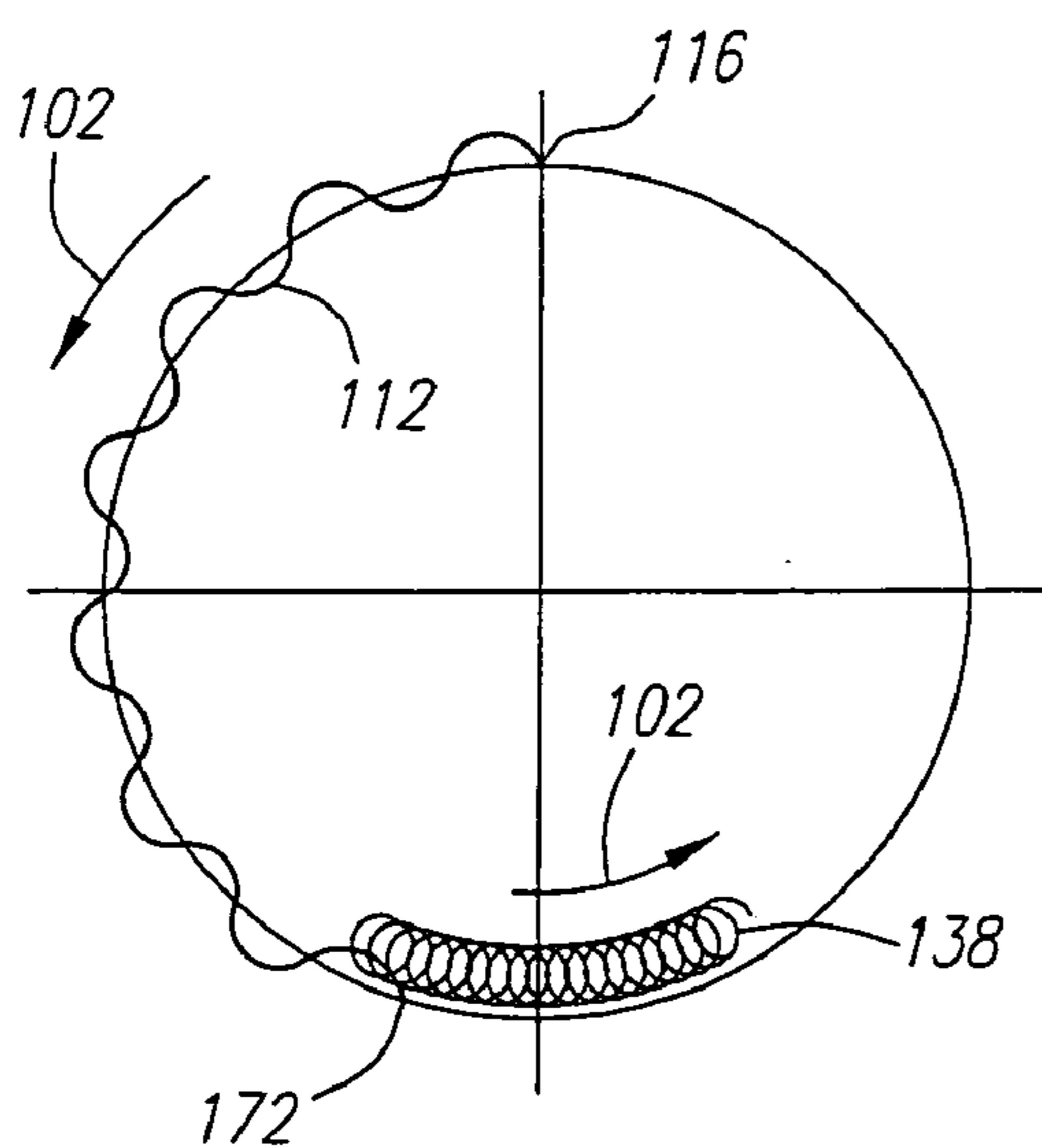


FIG. 12A

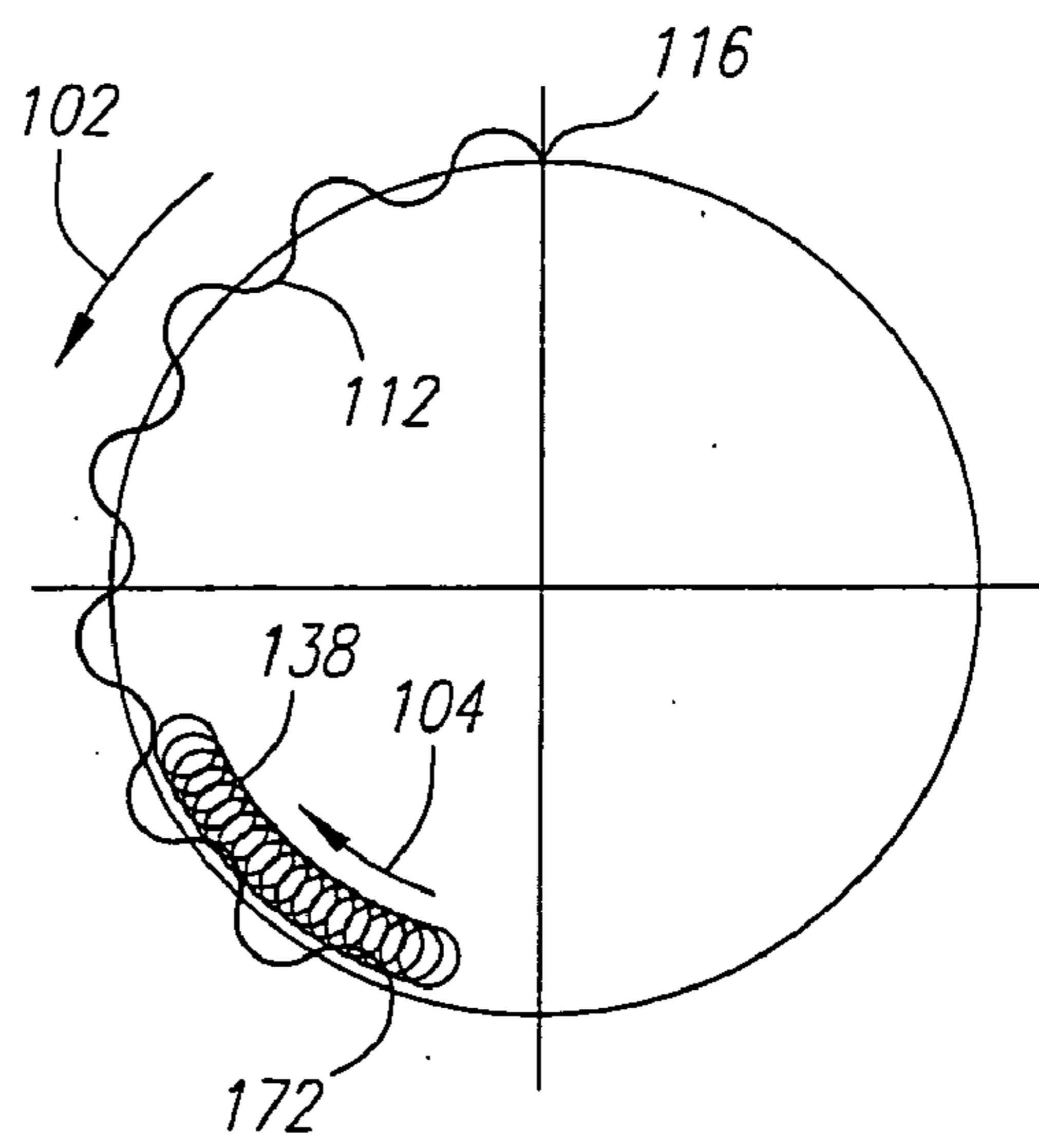


FIG. 12B

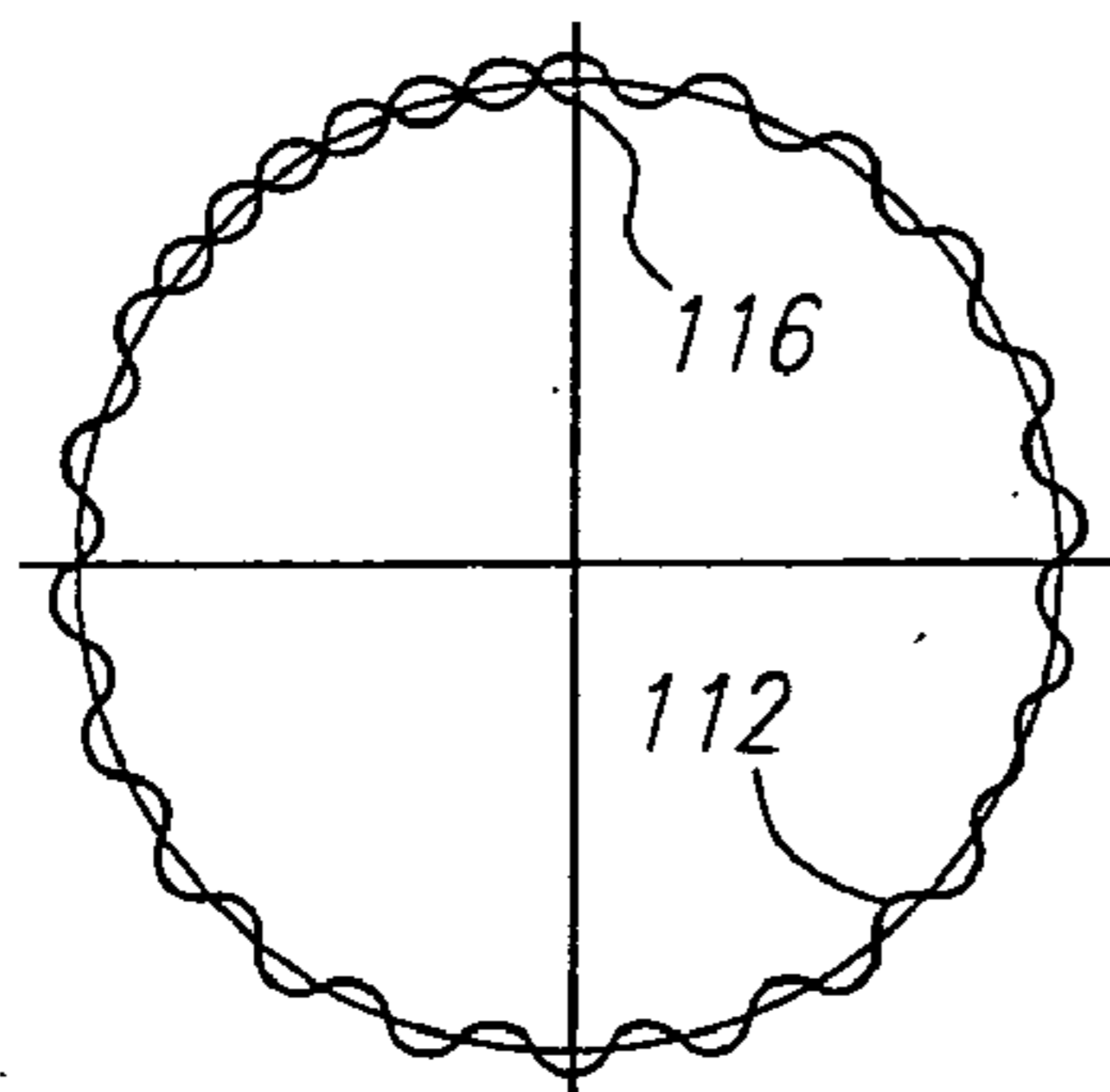


FIG. 13A

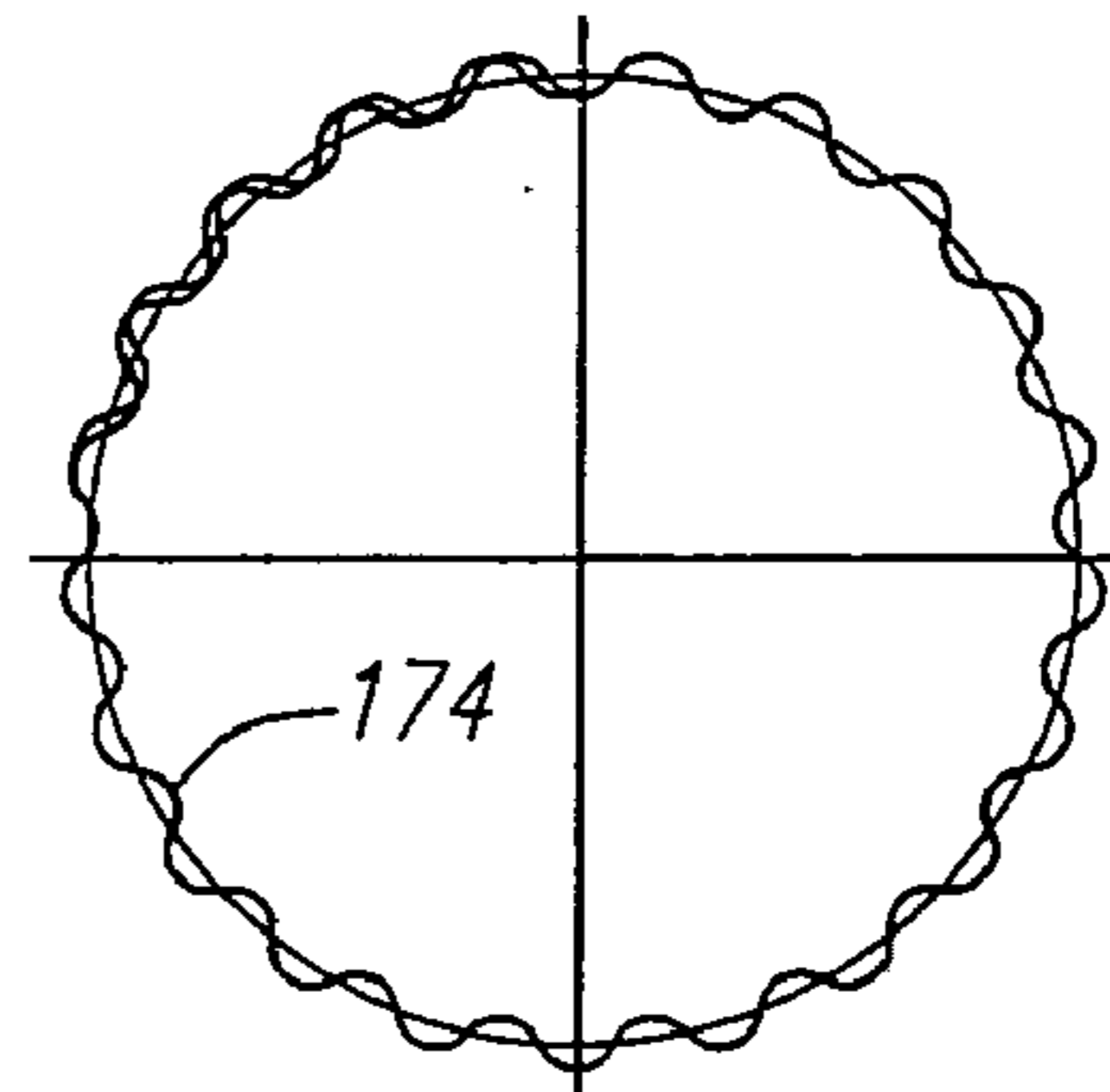


FIG. 13B

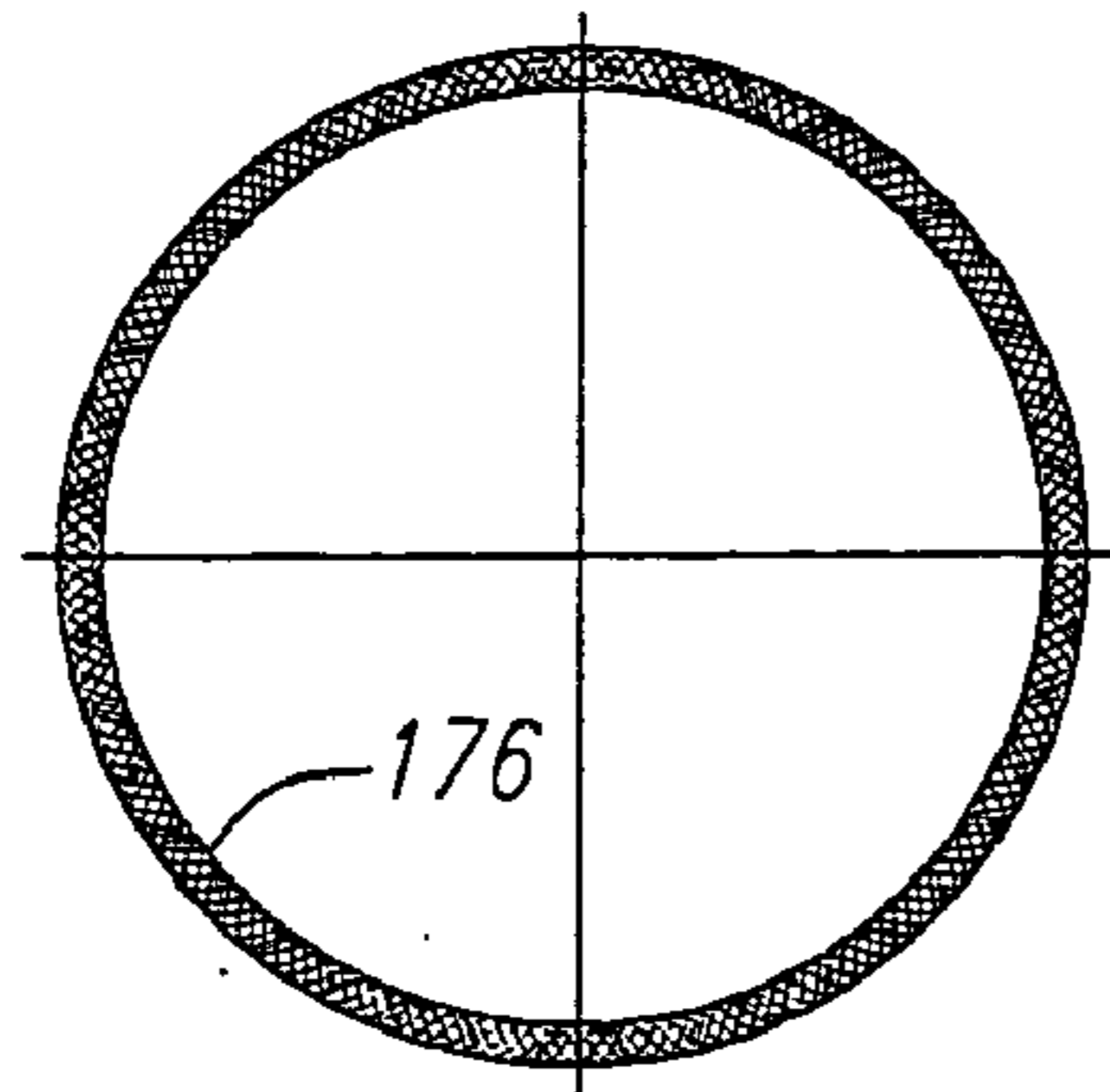


FIG. 13C

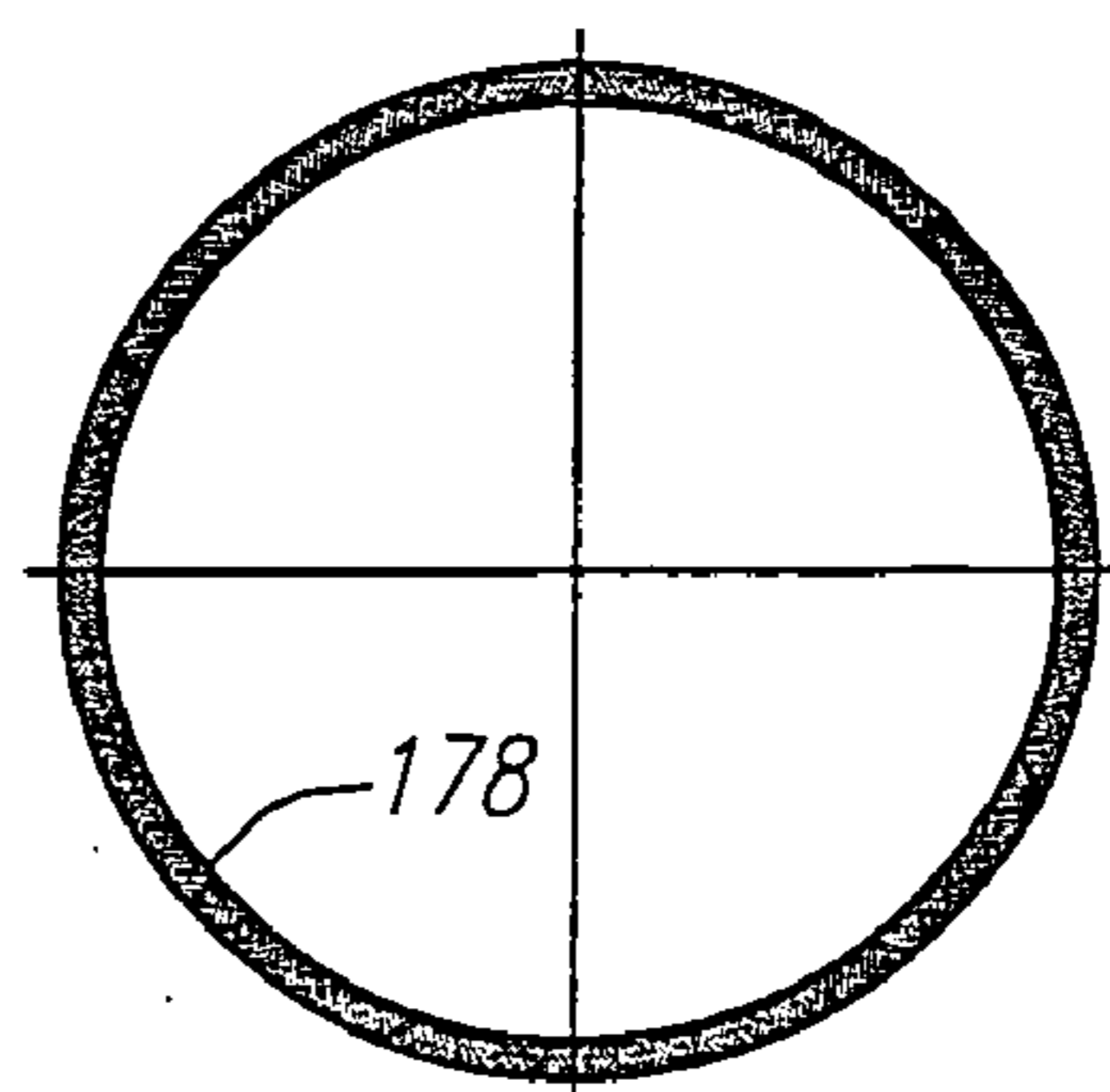
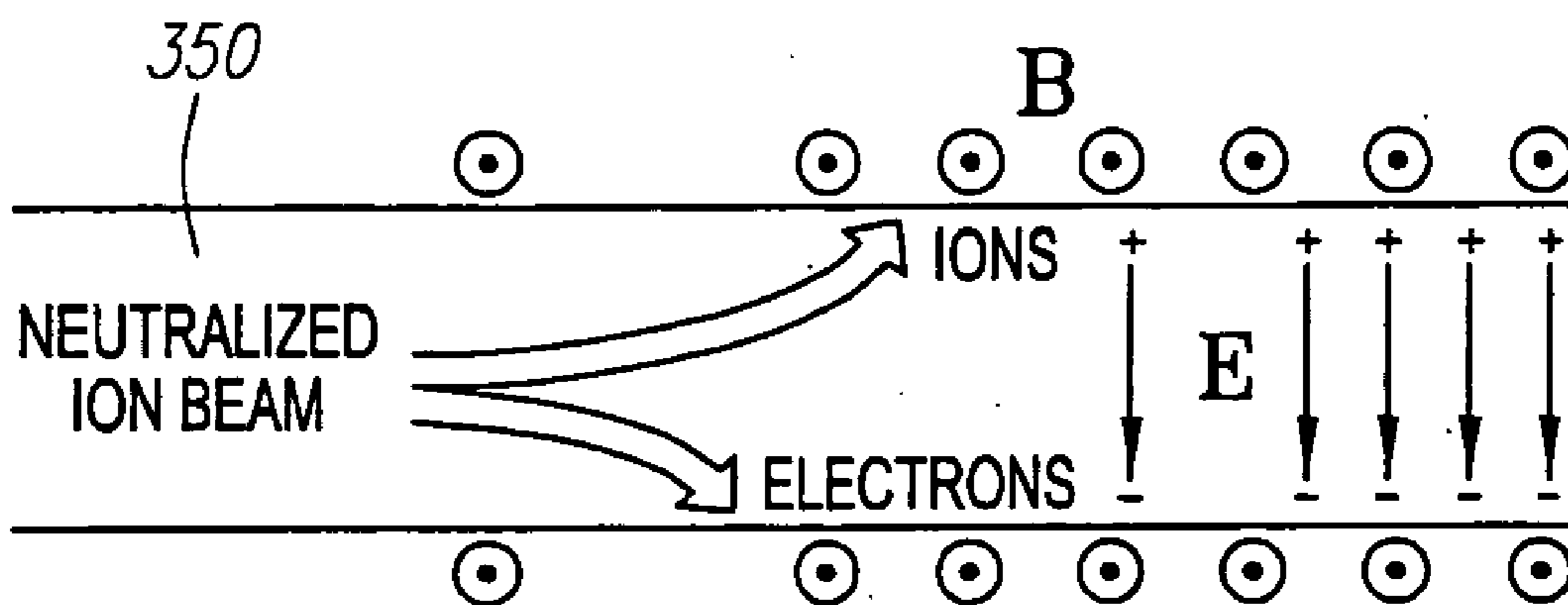
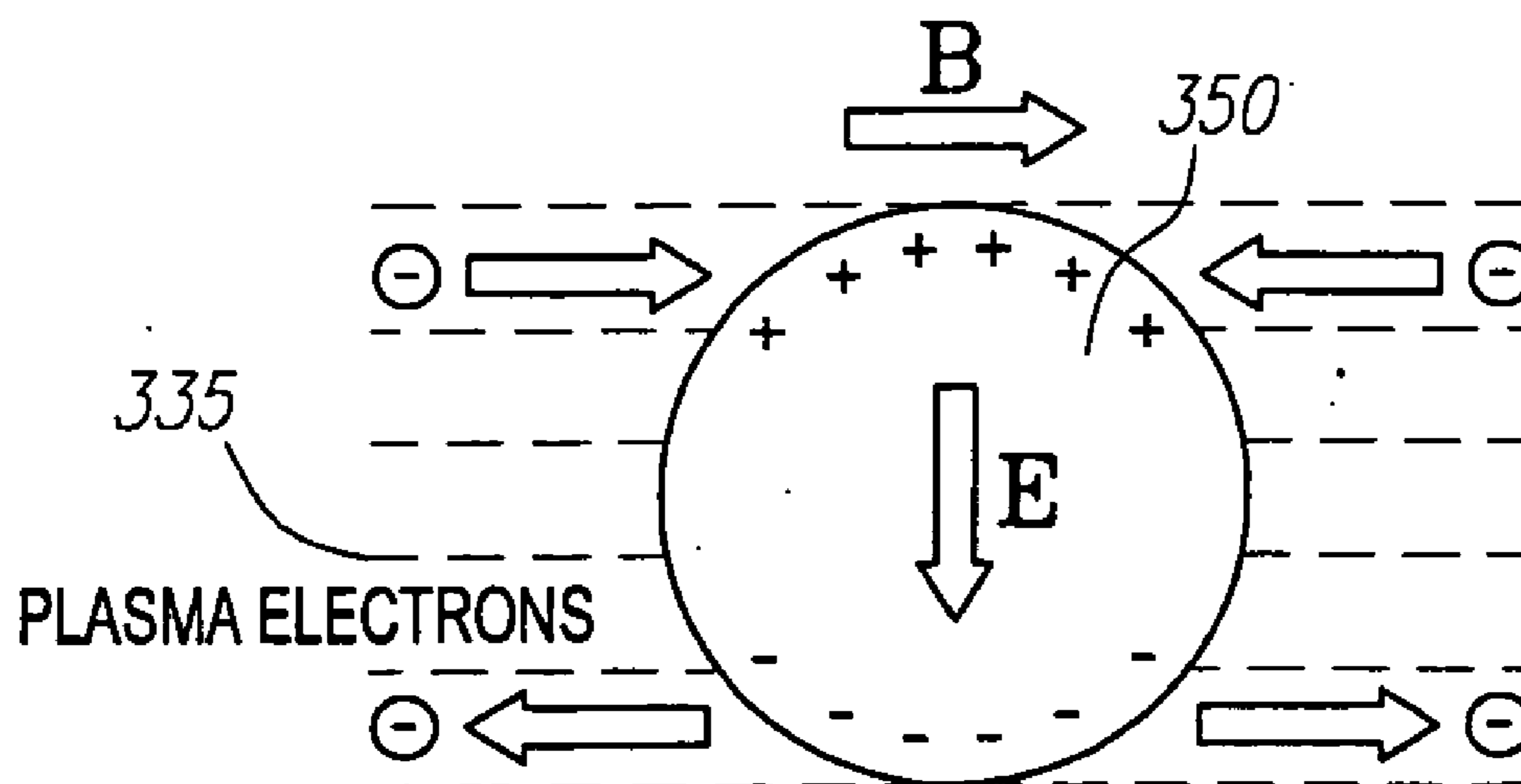


FIG. 13D

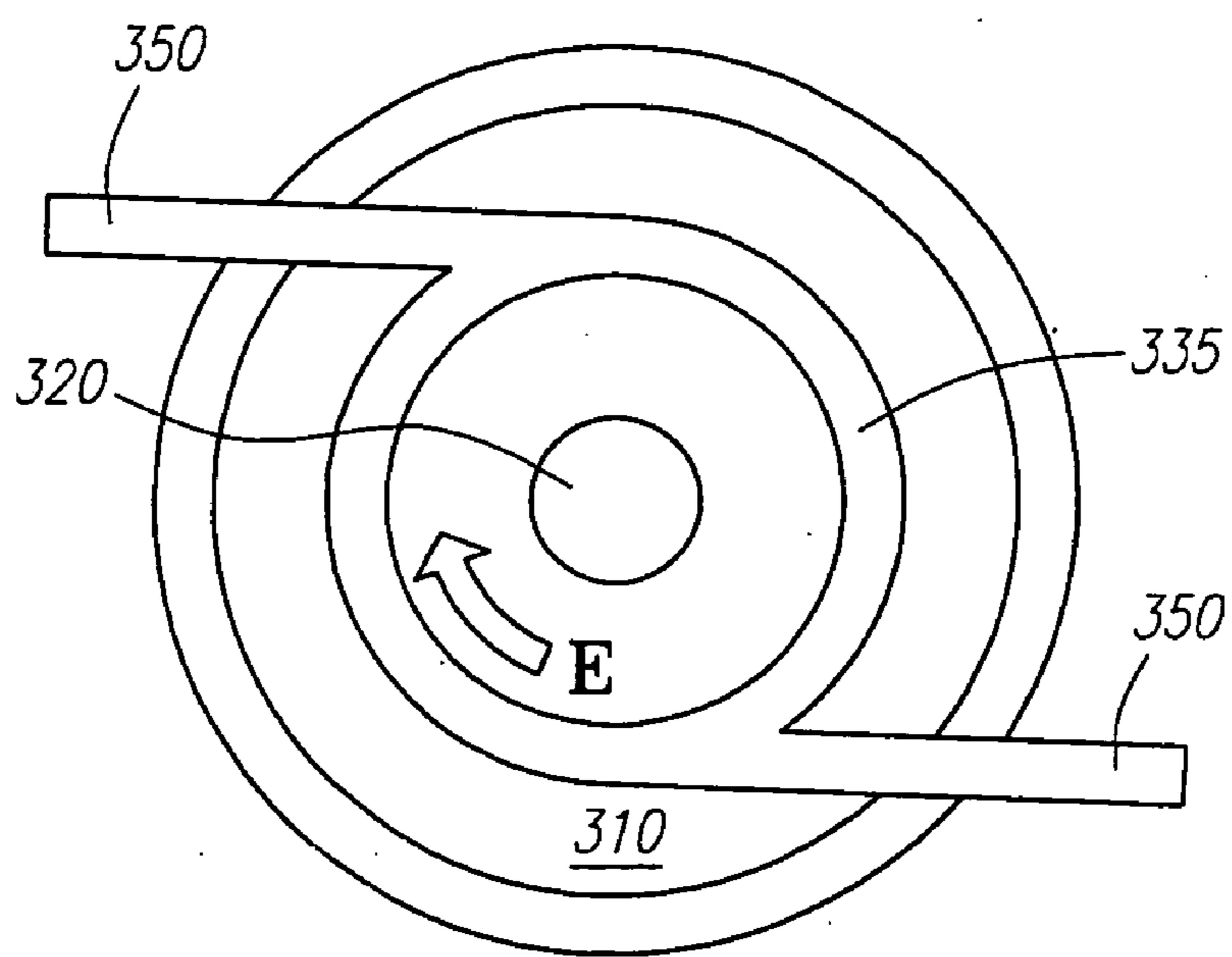


*FIG. 14*

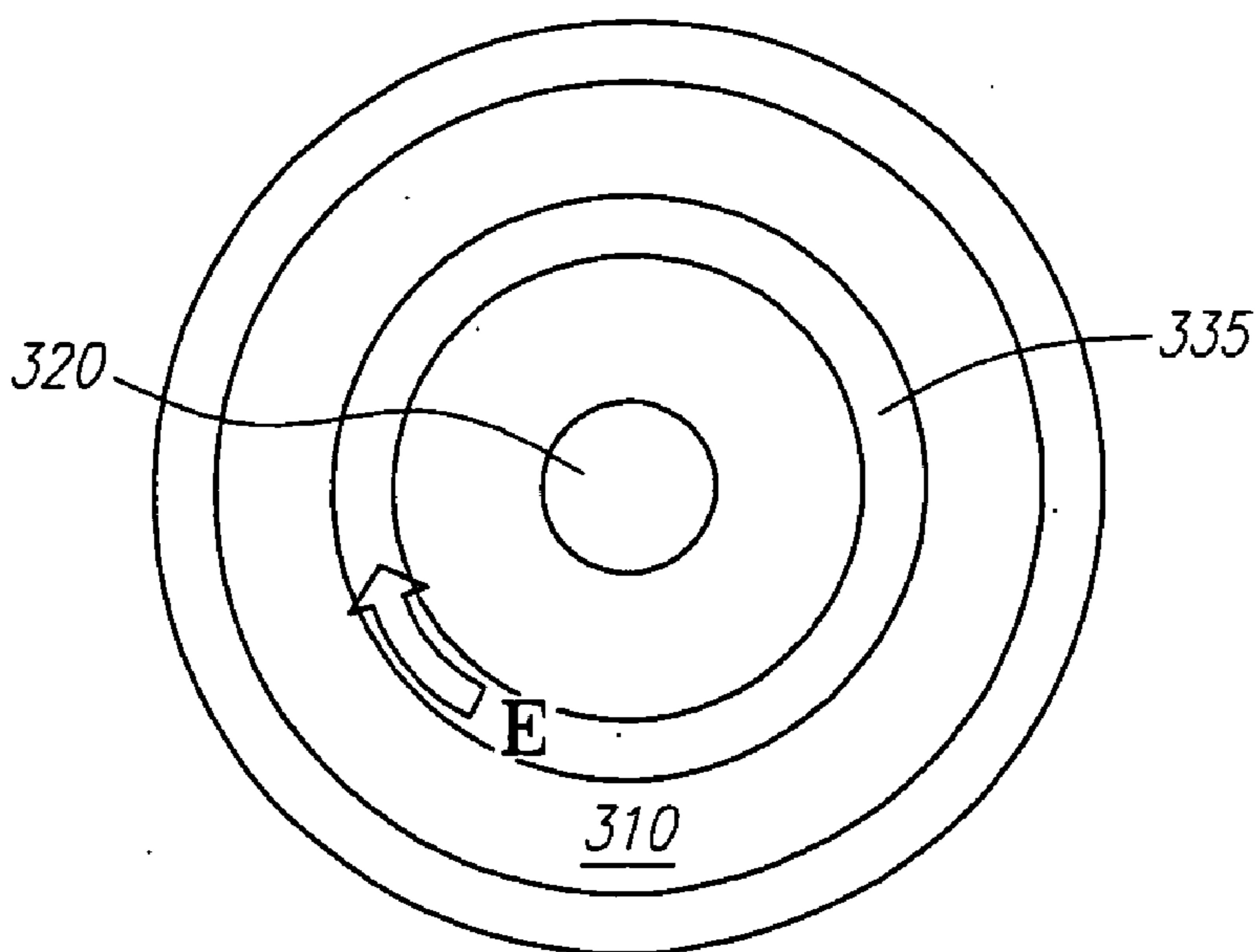


*FIG. 15*





*FIG. 16*



*FIG. 17*

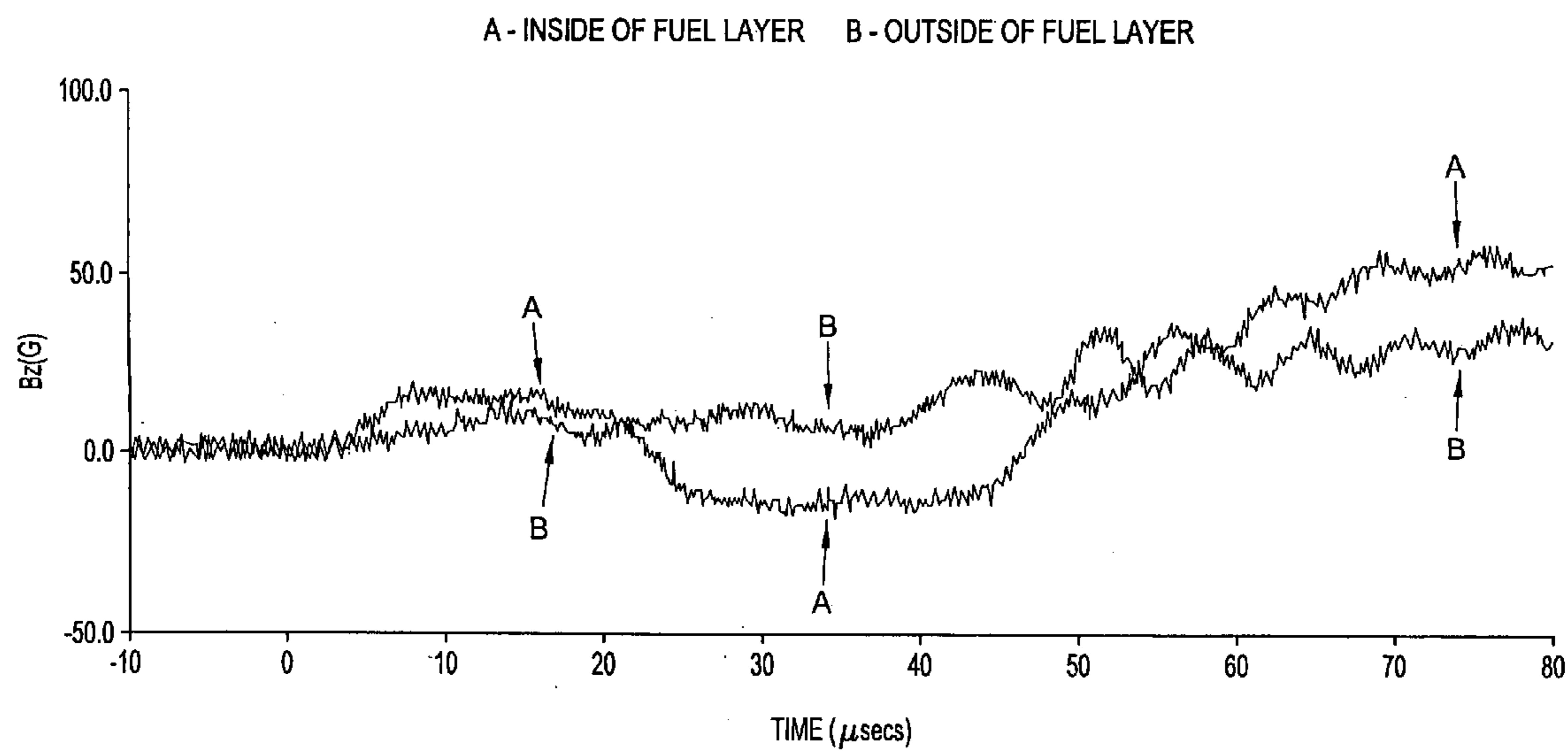


FIG. 18

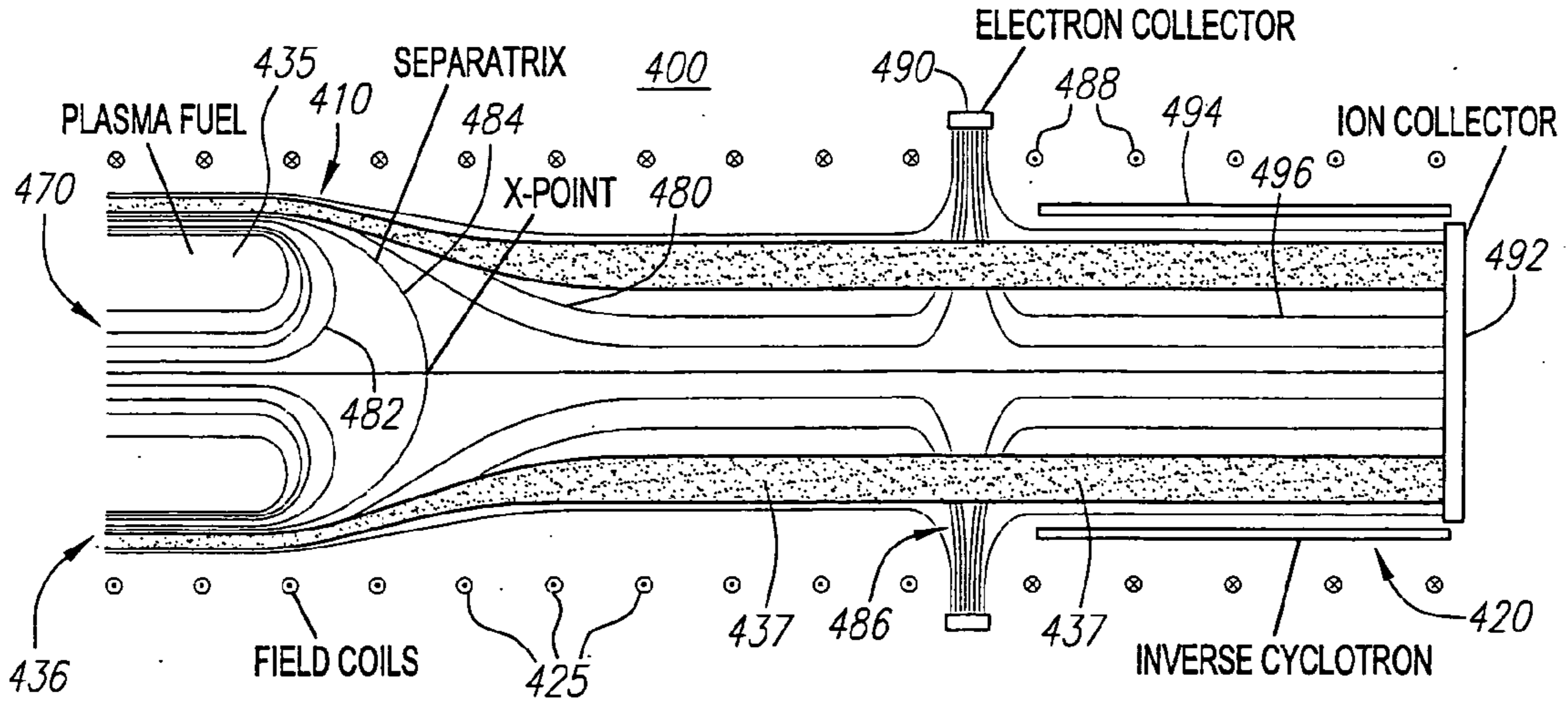


FIG. 19A

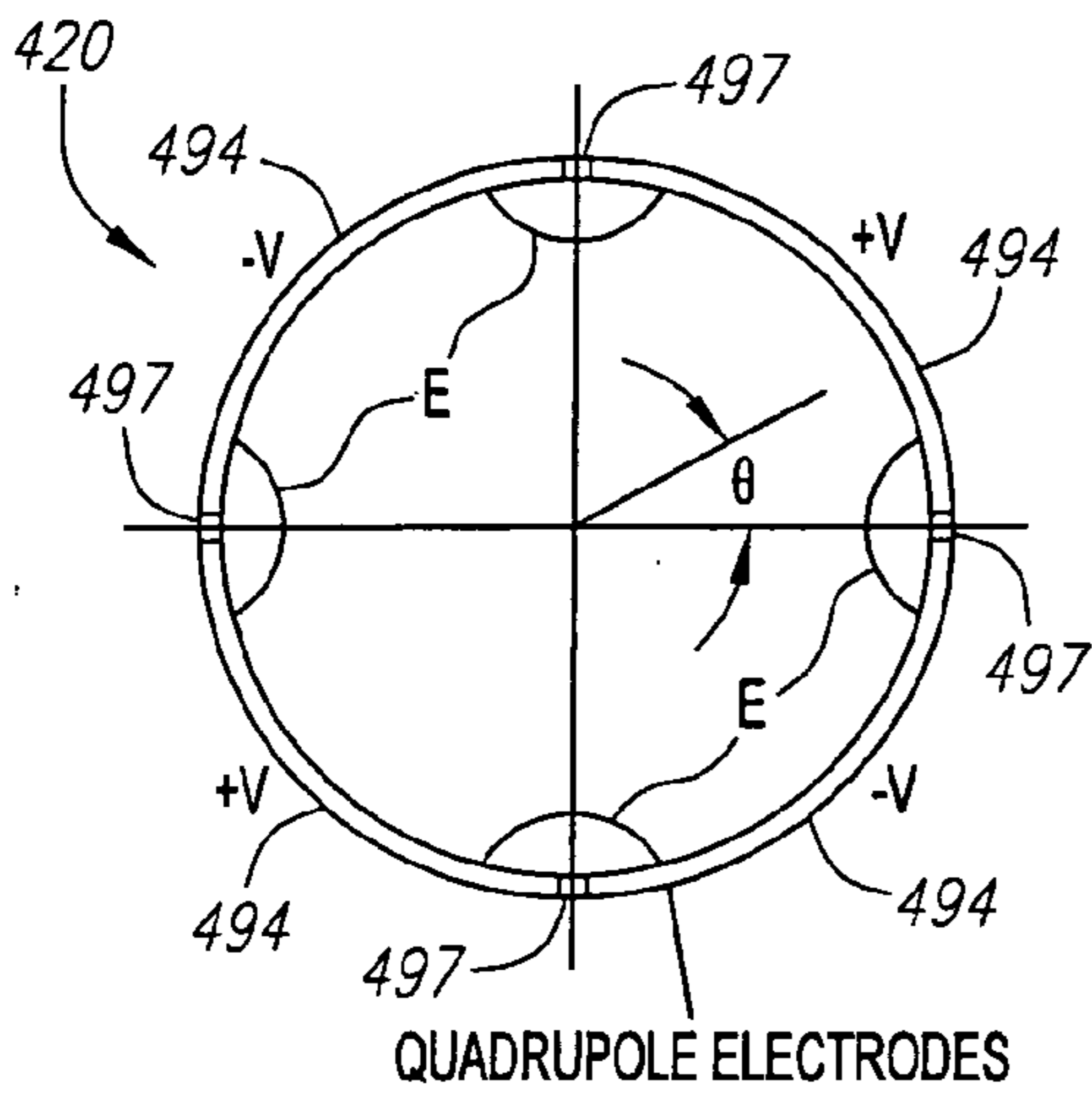
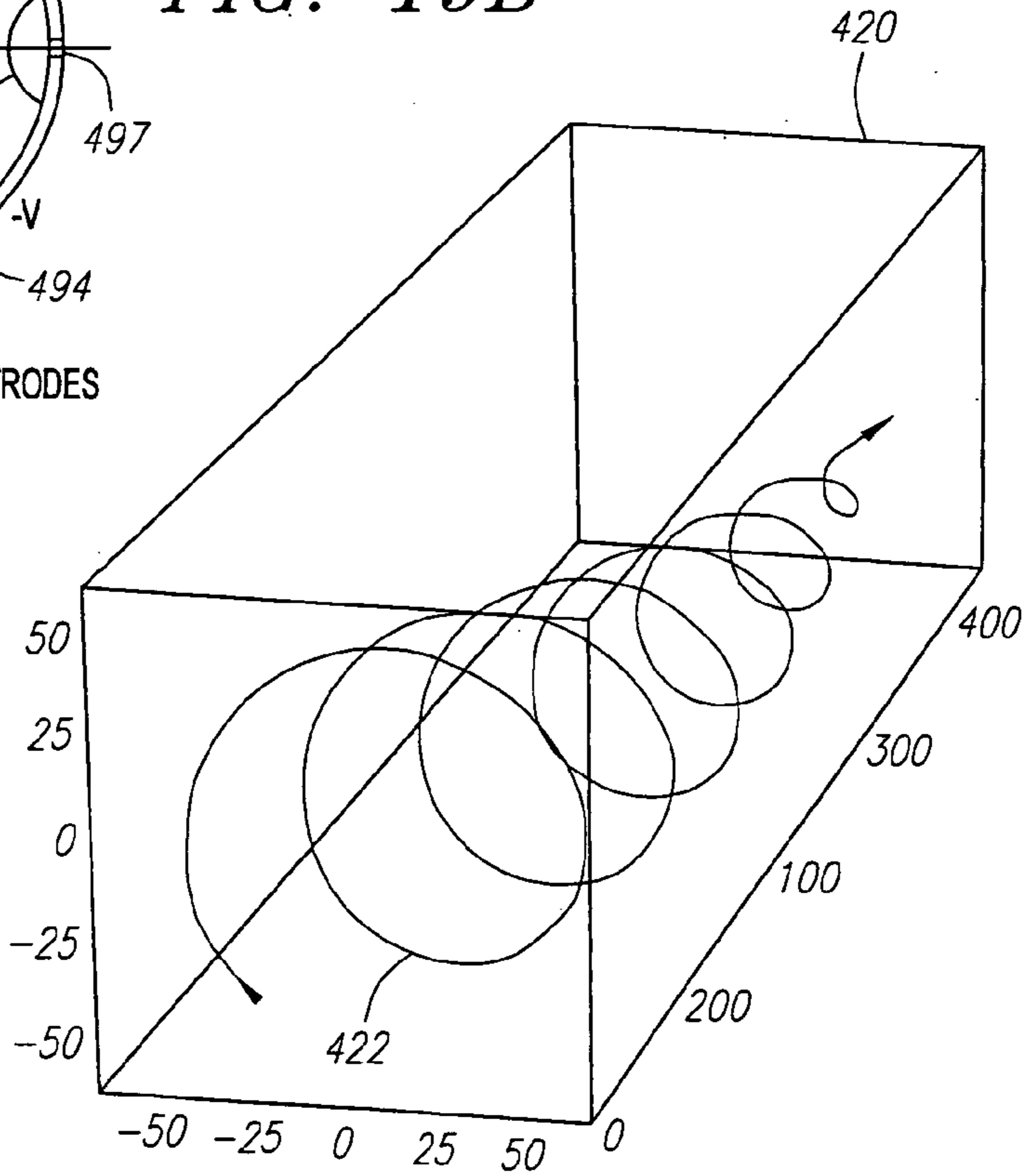


FIG. 19B

FIG. 19C



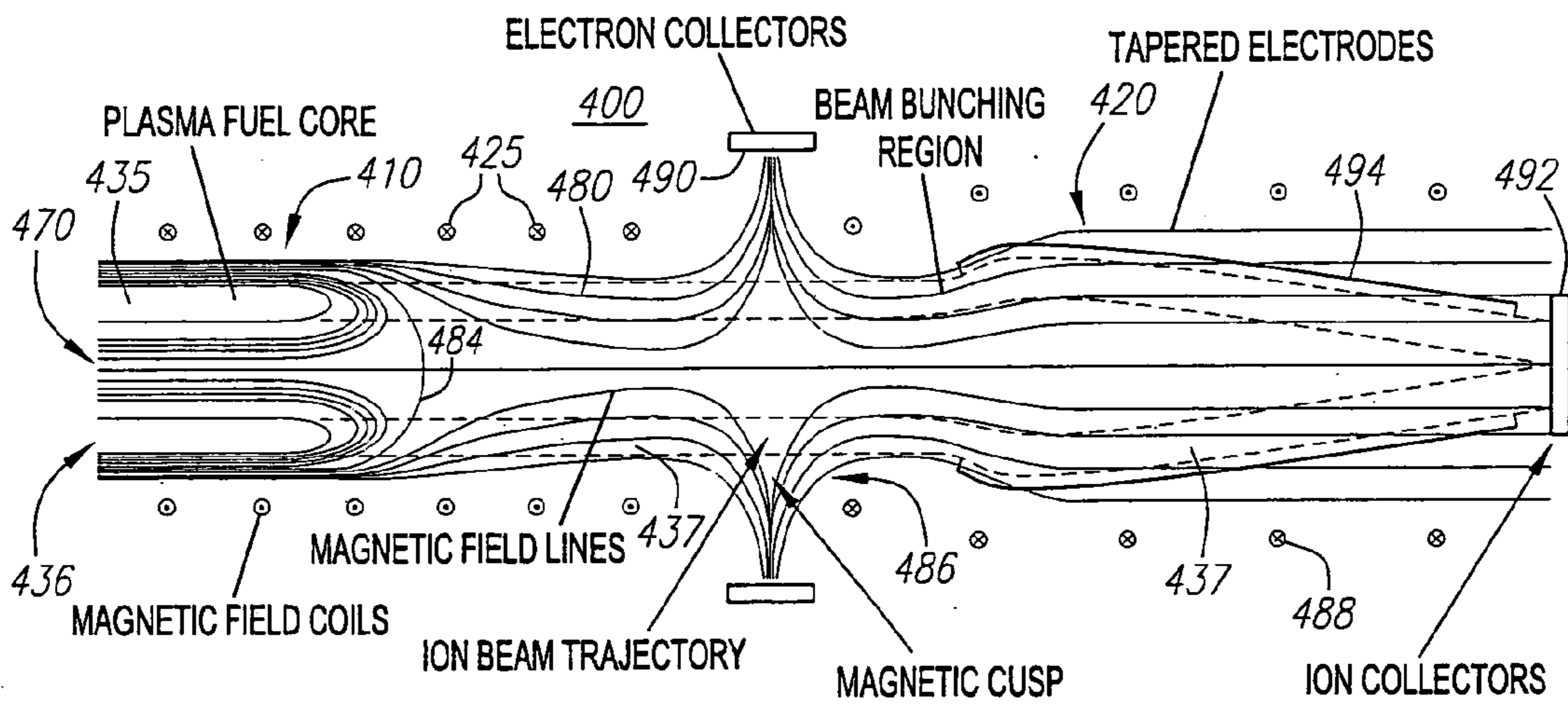


FIG. 20A

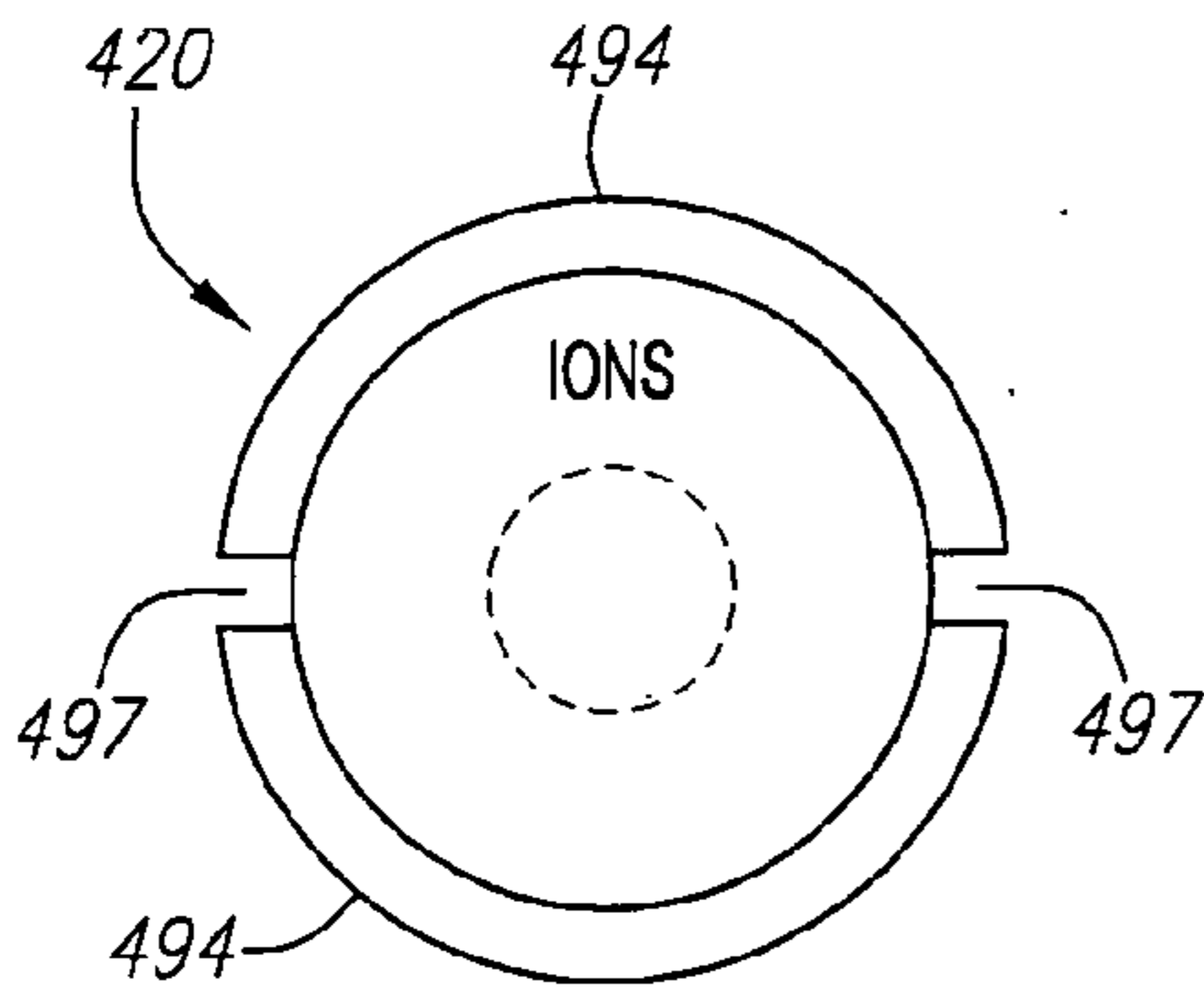


FIG. 20B

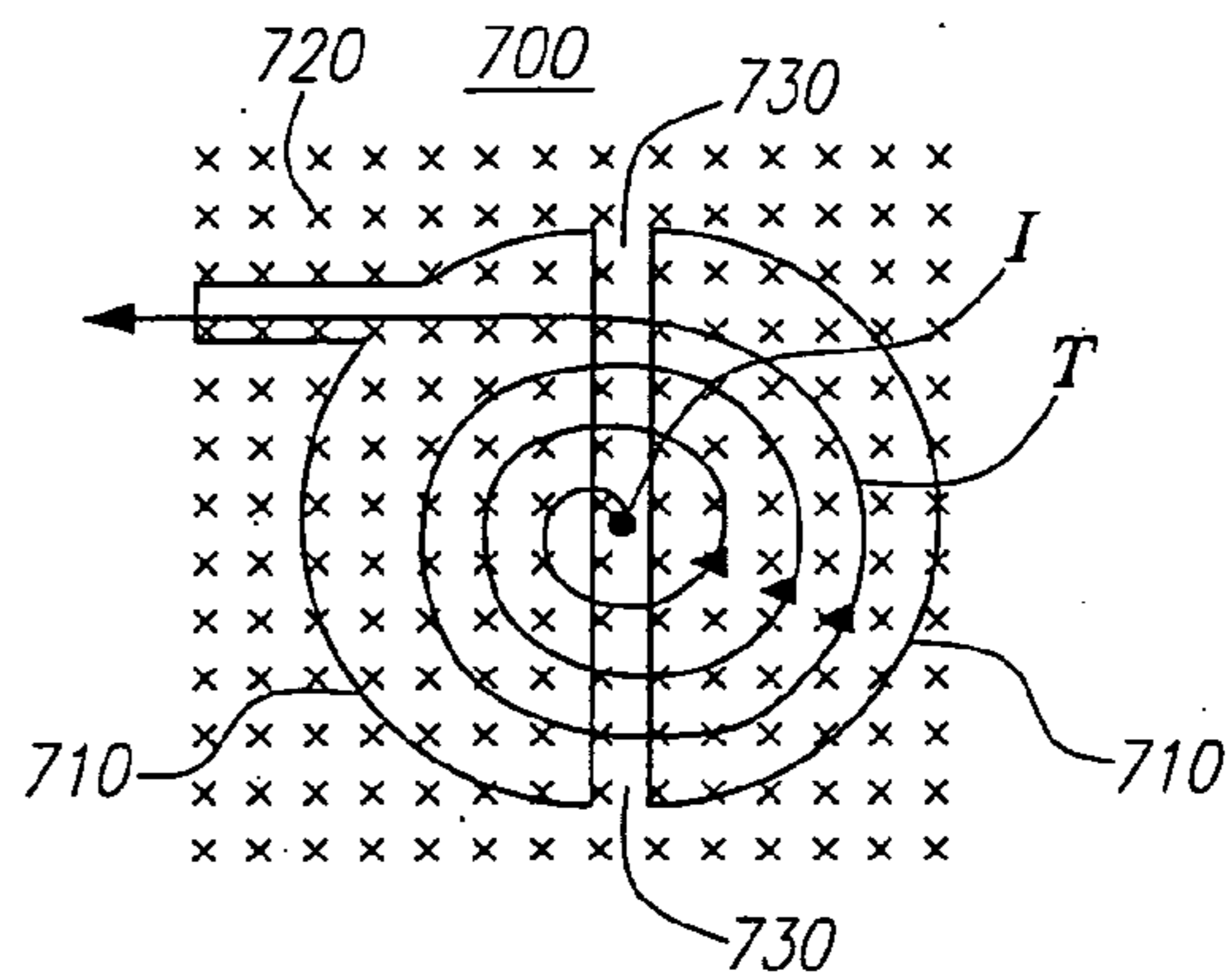


FIG. 21A

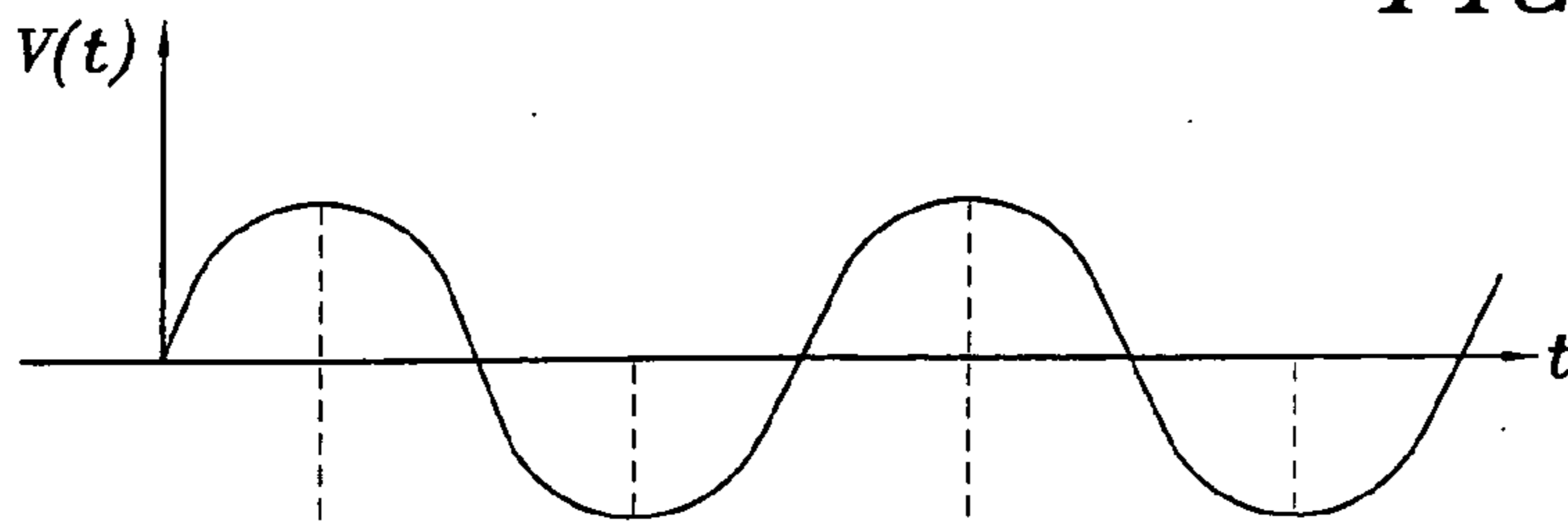


FIG. 21B

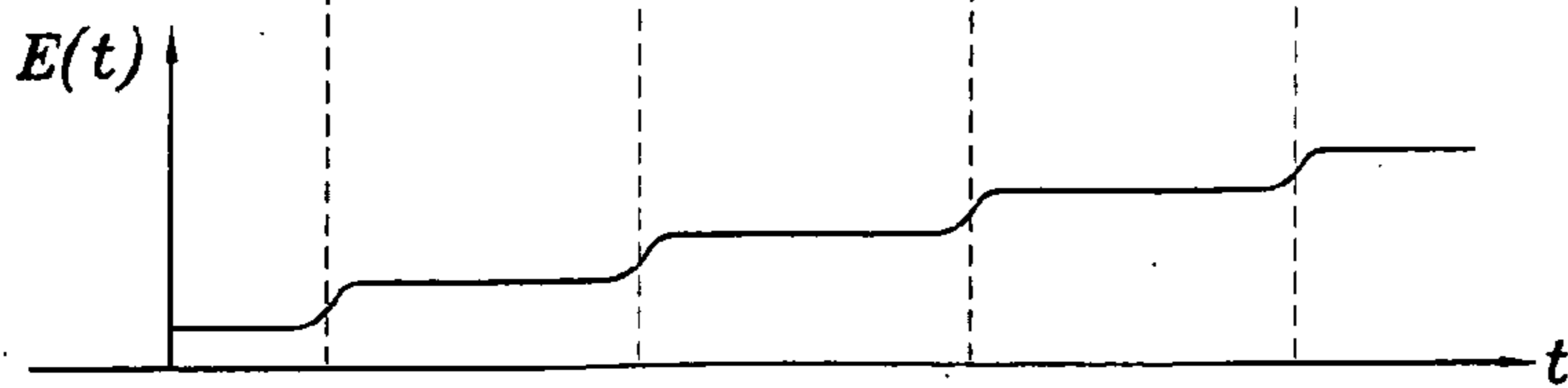


FIG. 21C

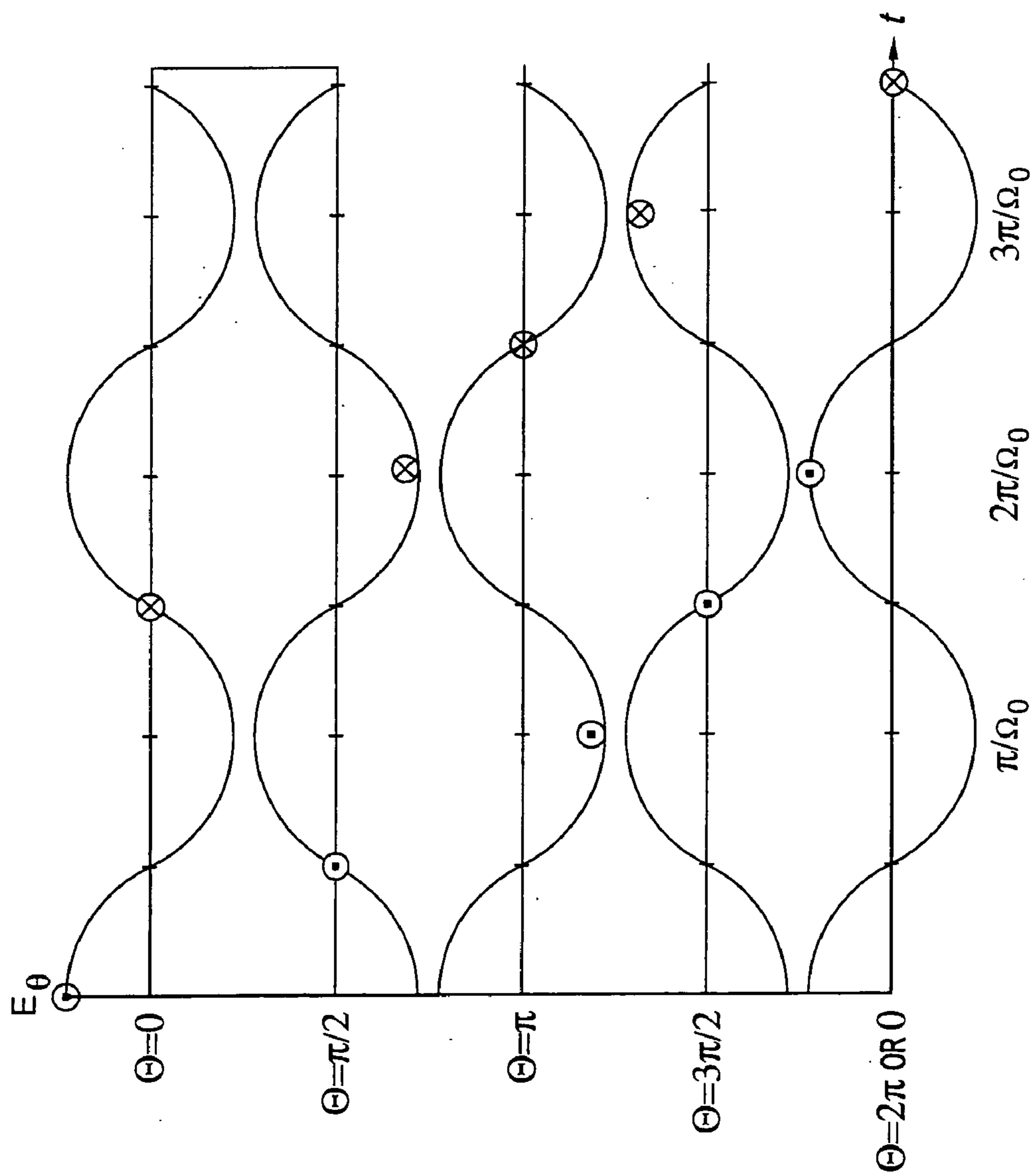
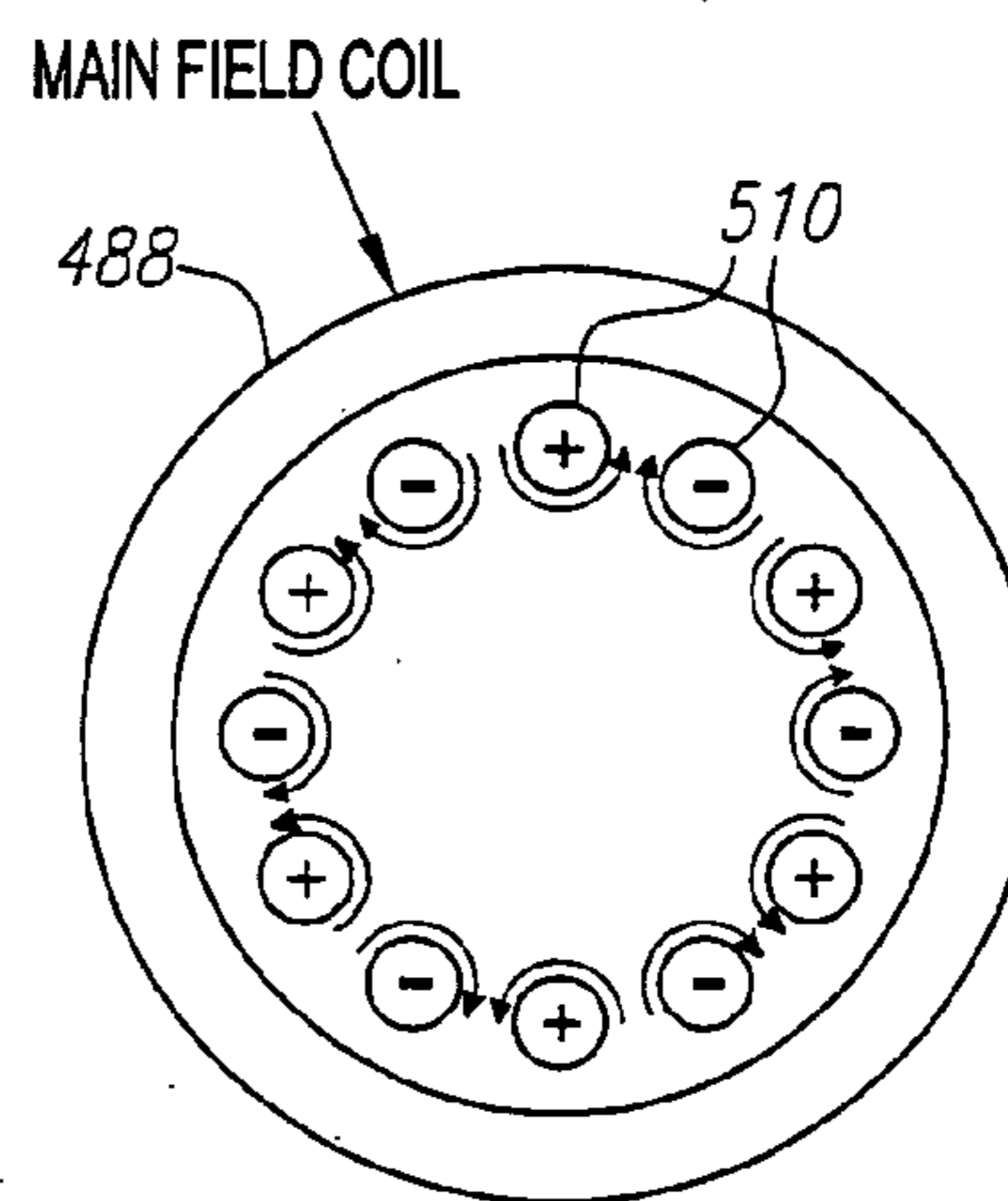
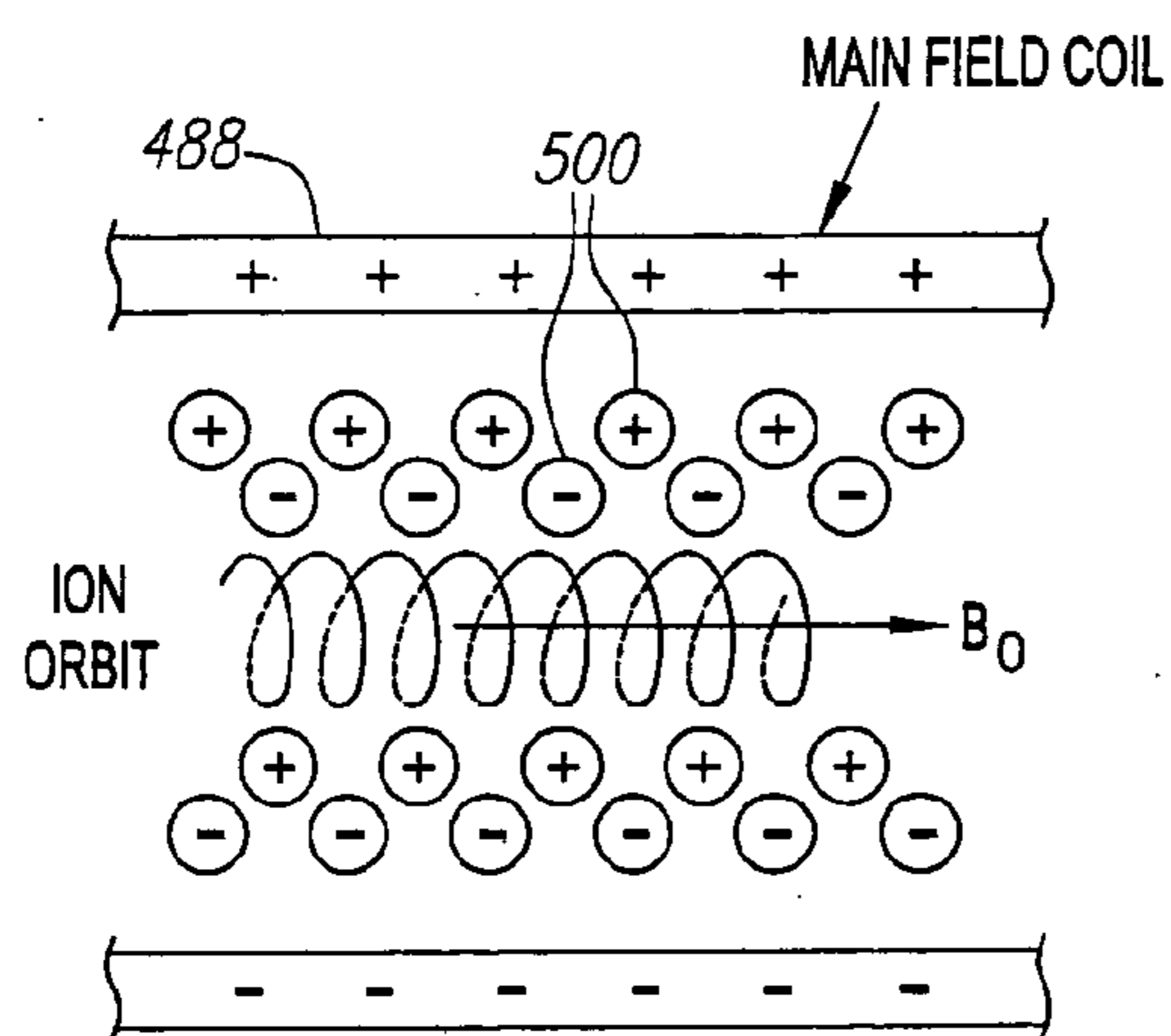
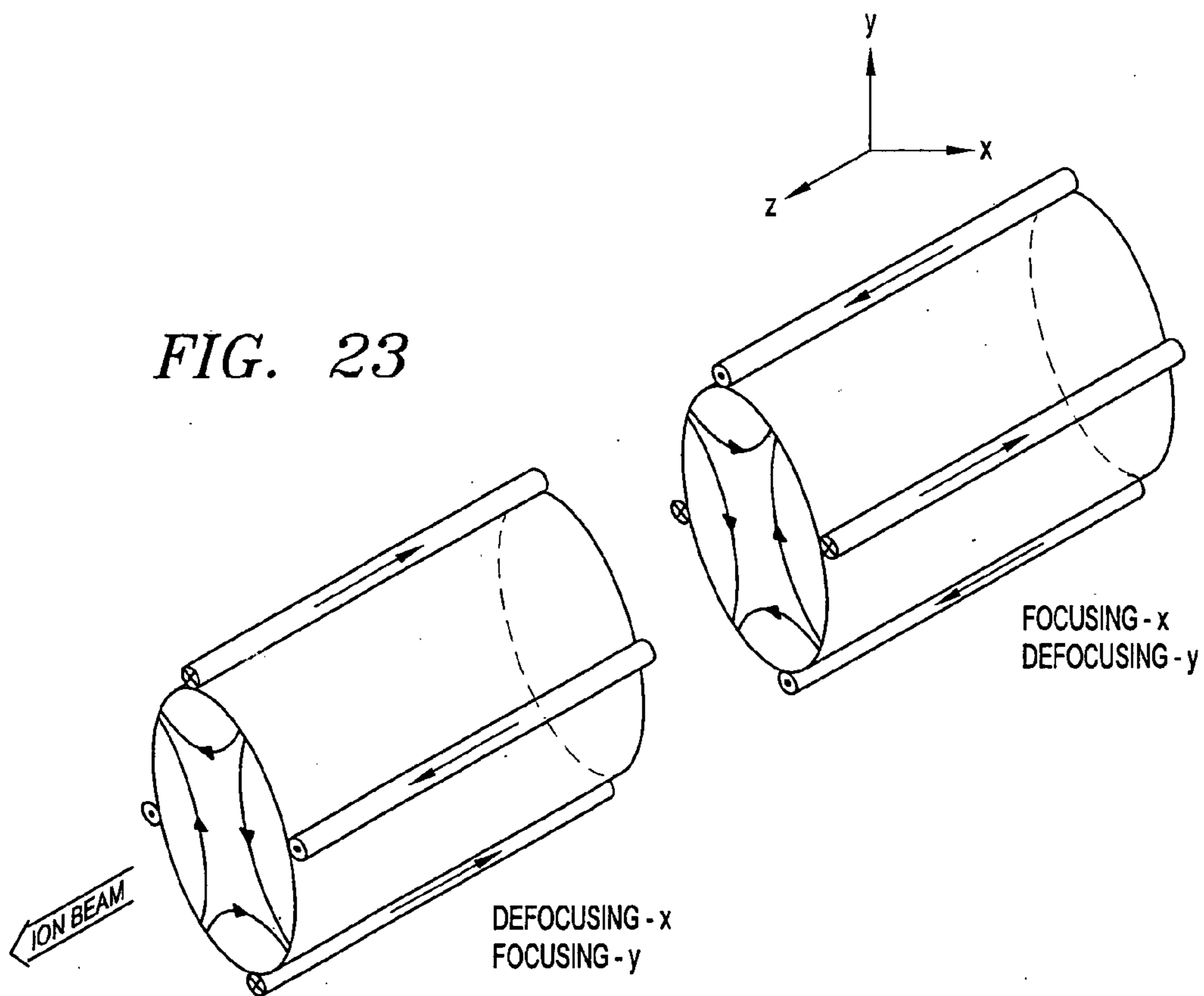


FIG. 22



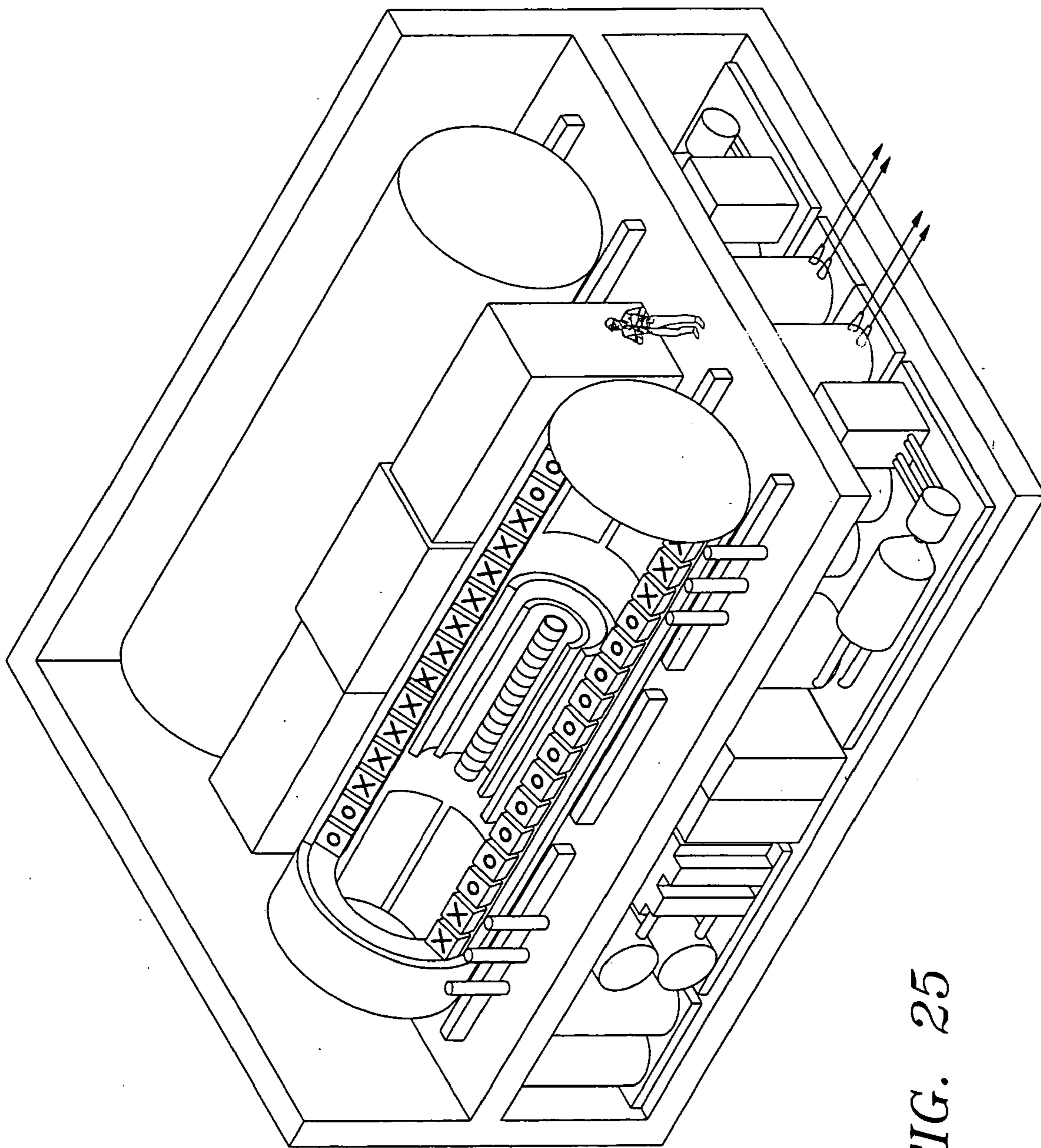
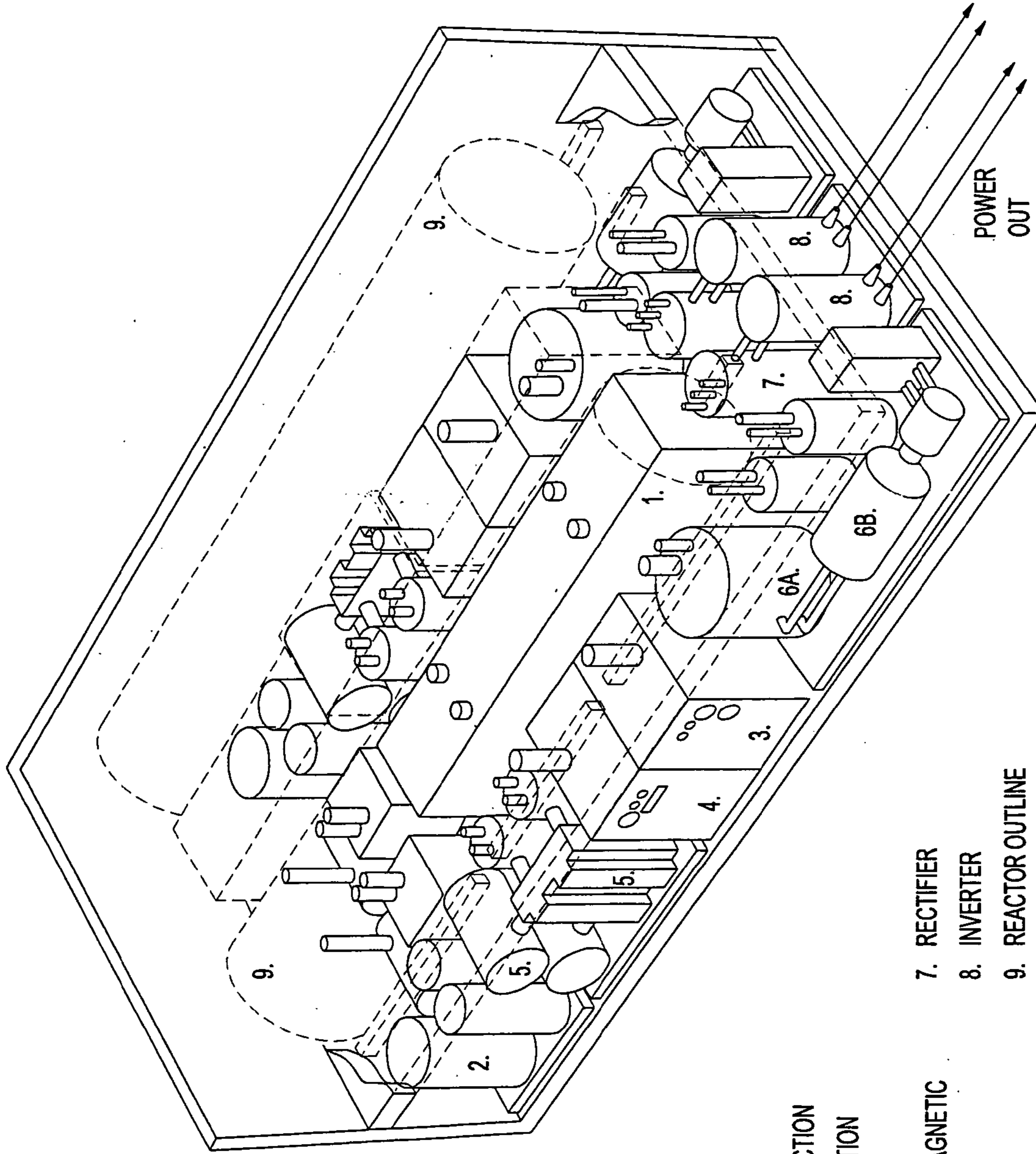


FIG. 25

FIG. 26



REACTOR  
SUPPORT  
EQUIPMENT

- 1. CAPACITOR BANK FOR  
INDUCTIVE START-UP
- 2. CRYOGENIC EQUIPMENT FOR  
SUPERCONDUCTING MAGNETS
- 3. ACCELERATOR FOR PROTON INJECTION
- 4. ACCELERATOR FOR BORON INJECTION
- 5. VACUUM PUMPS
- 6A. LITHIUM OR NAK TANK ELECTROMAGNETIC  
PUMP AND HEAT EXCHANGER
- 6B. STEAM TURBIN AND GENERATOR
- 7. RECTIFIER
- 8. INVERTER
- 9. REACTOR OUTLINE



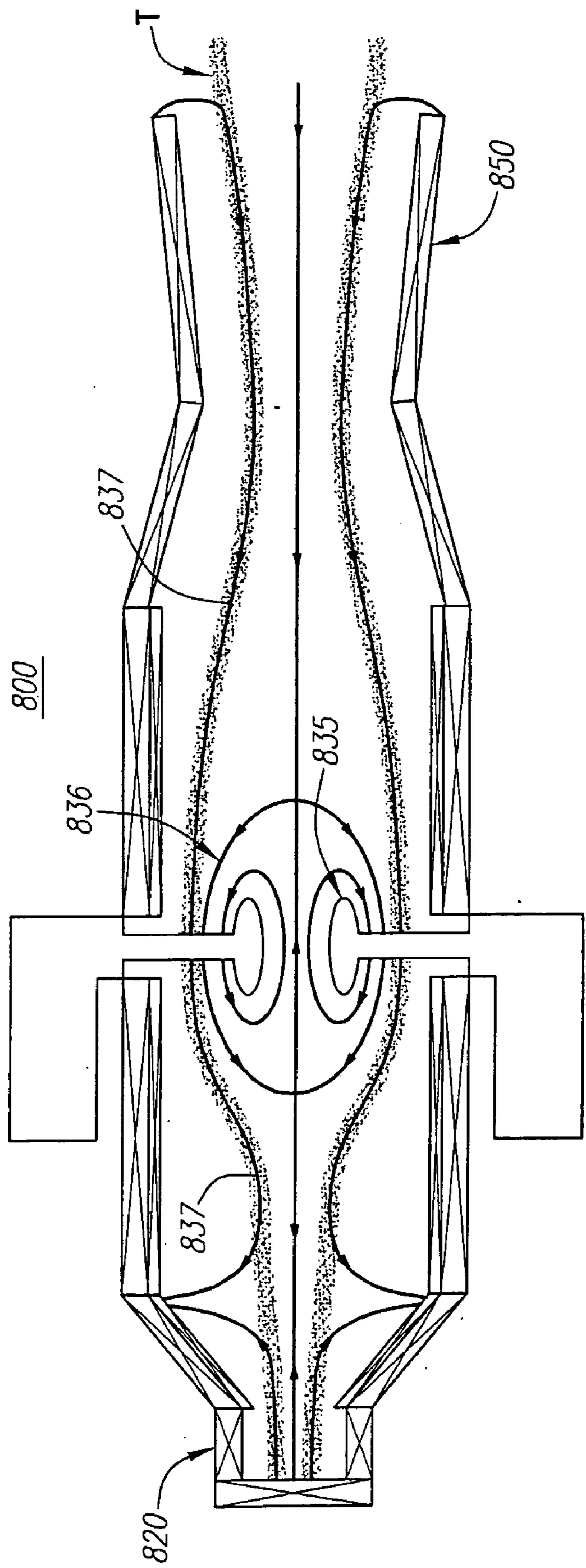


FIG. 27

**CONTROLLED FUSION IN A FIELD  
REVERSED CONFIGURATION AND DIRECT  
ENERGY CONVERSION**

CROSS-REFERENCE TO RELATED  
APPLICATIONS

**[0001]** This application is a continuation of U.S. application Ser. No. 10/982,515, filed Nov. 5, 2004, which is a divisional of U.S. application Ser. No. 10/410,830, filed Apr. 9, 2003, which is a continuation of U.S. application Ser. No. 10/076,793, filed Feb. 14, 2002, which claims the benefit of U.S. provisional application Ser. No. 60/277,374, filed Mar. 19, 2001, and U.S. provisional application Ser. No. 60/297,086, filed on Jun. 8, 2001, which applications are fully incorporated herein by reference.

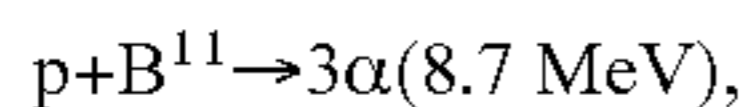
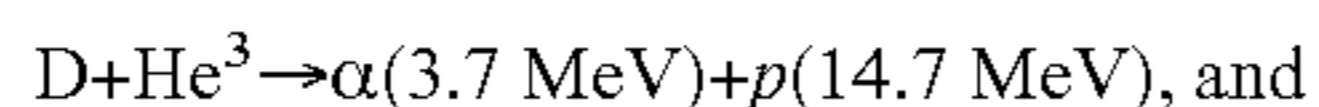
FIELD OF THE INVENTION

**[0002]** The invention relates generally to the field of plasma physics, and, in particular, to methods and apparatus for confining plasma to enable nuclear fusion and for converting energy from fusion products into electricity.

BACKGROUND OF THE INVENTION

**[0003]** Fusion is the process by which two light nuclei combine to form a heavier one. The fusion process releases a tremendous amount of energy in the form of fast moving particles. Because atomic nuclei are positively charged—due to the protons contained therein—there is a repulsive electrostatic, or Coulomb, force between them. For two nuclei to fuse, this repulsive barrier must be overcome, which occurs when two nuclei are brought close enough together where the short-range nuclear forces become strong enough to overcome the Coulomb force and fuse the nuclei. The energy necessary for the nuclei to overcome the Coulomb barrier is provided by their thermal energies, which must be very high. For example, the fusion rate can be appreciable if the temperature is at least of the order of  $10^8$  eV—corresponding roughly to 100 million degrees Kelvin. The rate of a fusion reaction is a function of the temperature, and it is characterized by a quantity called reactivity. The reactivity of a D-T reaction, for example, has a broad peak between 30 keV and 100 keV.

**[0004]** Typical fusion reactions include:



where D indicates deuterium, T indicates tritium,  $\alpha$  indicates a helium nucleus, n indicates a neutron, p indicates a proton, He indicates helium, and  $B^{11}$  indicates Boron-11. The numbers in parentheses in each equation indicate the kinetic energy of the fusion products.

**[0005]** The first two reactions listed above—the D-D and D-T reactions—are neutronic, which means that most of the energy of their fusion products is carried by fast neutrons. The disadvantages of neutronic reactions are that (1) the flux of fast neutrons creates many problems, including structural damage of the reactor walls and high levels of radioactivity for most construction materials; and (2) the energy of fast neutrons is collected by converting their thermal energy to

electric energy, which is very inefficient (less than 30%). The advantages of neutronic reactions are that (1) their reactivity peaks at a relatively low temperature; and (2) their losses due to radiation are relatively low because the atomic numbers of deuterium and tritium are 1.

**[0006]** The reactants in the other two equations—D-He<sup>3</sup> and p-B<sup>11</sup>—are called advanced fuels. Instead of producing fast neutrons, as in the neutronic reactions, their fusion products are charged particles. One advantage of the advanced fuels is that they create much fewer neutrons and therefore suffer less from the disadvantages associated with them. In the case of D-He<sup>3</sup>, some fast neutrons are produced by secondary reactions, but these neutrons account for only about 10 percent of the energy of the fusion products. The p-B<sup>11</sup> reaction is free of fast neutrons, although it does produce some slow neutrons that result from secondary reactions but create much fewer problems. Another advantage of the advanced fuels is that their fusion products comprise charged particles whose kinetic energy may be directly convertible to electricity. With an appropriate direct energy conversion process, the energy of advanced fuel fusion products may be collected with a high efficiency, possibly in excess of 90 percent.

**[0007]** The advanced fuels have disadvantages, too. For example, the atomic numbers of the advanced fuels are higher (2 for He<sup>3</sup> and 5 for B<sup>11</sup>). Therefore, their radiation losses are greater than in the neutronic reactions. Also, it is much more difficult to cause the advanced fuels to fuse. Their peak reactivities occur at much higher temperatures and do not reach as high as the reactivity for D-T. Causing a fusion reaction with the advanced fuels thus requires that they be brought to a higher energy state where their reactivity is significant. Accordingly, the advanced fuels must be contained for a longer time period wherein they can be brought to appropriate fusion conditions.

**[0008]** The containment time for a plasma is  $\Delta t = r^2/D$ , where r is a minimum plasma dimension and D is a diffusion coefficient. The classical value of the diffusion coefficient is  $D_c = a_i^2/\tau_{ie}$ , where  $a_i$  is the ion gyroradius and  $\tau_{ie}$  is the ion-electron collision time. Diffusion according to the classical diffusion coefficient is called classical transport. The Bohm diffusion coefficient, attributed to short-wavelength instabilities, is  $D_B = (1/16)a_i^2\Omega_i$ , where  $\Omega_i$  is the ion gyrofrequency. Diffusion according to this relationship is called anomalous transport. For fusion conditions,  $D_B/D_c = (1/16)\Omega_i\tau_{ie} \approx 10^8$ , anomalous transport results in a much shorter containment time than does classical transport. This relation determines how large a plasma must be in a fusion reactor, by the requirement that the containment time for a given amount of plasma must be longer than the time for the plasma to have a nuclear fusion reaction. Therefore, classical transport condition is more desirable in a fusion reactor, allowing for smaller initial plasmas.

**[0009]** In early experiments with toroidal confinement of plasma, a containment time of  $\Delta t \approx r^2/D_B$  was observed. Progress in the last 40 years has increased the containment time to  $\Delta t \approx 1000 r^2/D_B$ . One existing fusion reactor concept is the Tokamak. For the past 30 years, fusion efforts have been focussed on the Tokamak reactor using a D-T fuel. These efforts have culminated in the International Thermonuclear Experimental Reactor (ITER). Recent experiments with Tokamaks suggest that classical transport,  $\Delta t \approx r^2/D_c$ , is possible, in which case the minimum plasma dimension can be reduced from meters to centimeters. These experiments

involved the injection of energetic beams (50 to 100 keV), to heat the plasma to temperatures of 10 to 30 keV. See W. Heidbrink & G. J. Sadler, 34 *Nuclear Fusion* 535 (1994). The energetic beam ions in these experiments were observed to slow down and diffuse classically while the thermal plasma continued to diffuse anomalously fast. The reason for this is that the energetic beam ions have a large gyroradius and, as such, are insensitive to fluctuations with wavelengths shorter than the ion gyroradius ( $\lambda < a_i$ ). The short-wavelength fluctuations tend to average over a cycle and thus cancel. Electrons, however, have a much smaller gyroradius, so they respond to the fluctuations and transport anomalously.

**[0010]** Because of anomalous transport, the minimum dimension of the plasma must be at least 2.8 meters. Due to this dimension, the ITER was created 30 meters high and 30 meters in diameter. This is the smallest D-T Tokamak-type reactor that is feasible. For advanced fuels, such as D-He<sup>3</sup> and p-B<sup>11</sup> the Tokamak-type reactor would have to be much larger because the time for a fuel ion to have a nuclear reaction is much longer. A Tokamak reactor using D-T fuel has the additional problem that most of the energy of the fusion products energy is carried by 14 MeV neutrons, which cause radiation damage and induce reactivity in almost all construction materials due to the neutron flux. In addition, the conversion of their energy into electricity must be by a thermal process, which is not more than 30% efficient.

**[0011]** Another proposed reactor configuration is a colliding beam reactor. In a colliding beam reactor, a background plasma is bombarded by beams of ions. The beams comprise ions with an energy that is much larger than the thermal plasma. Producing useful fusion reactions in this type of reactor has been infeasible because the background plasma slows down the ion beams. Various proposals have been made to reduce this problem and maximize the number of nuclear reactions.

**[0012]** For example, U.S. Pat. No. 4,065,351 to Jassby et al. discloses a method of producing counterstreaming colliding beams of deuterons and tritons in a toroidal confinement system. In U.S. Pat. No. 4,057,462 to Jassby et al., electromagnetic energy is injected to counteract the effects of bulk equilibrium plasma drag on one of the ion species. The toroidal confinement system is identified as a Tokamak. In U.S. Pat. No. 4,894,199 to Rostoker, beams of deuterium and tritium are injected and trapped with the same average velocity in a Tokamak, mirror, or field reversed configuration. There is a low density cool background plasma for the sole purpose of trapping the beams. The beams react because they have a high temperature, and slowing down is mainly caused by electrons that accompany the injected ions. The electrons are heated by the ions in which case the slowing down is minimal.

**[0013]** In none of these devices, however, does an equilibrium electric field play any part. Further, there is no attempt to reduce, or even consider, anomalous transport.

**[0014]** Other patents consider electrostatic confinement of ions and, in some cases, magnetic confinement of electrons. These include U.S. Pat. No. 3,258,402 to Farnsworth and U.S. Pat. No. 3,386,883 to Farnsworth, which disclose electrostatic confinement of ions and inertial confinement of electrons; U.S. Pat. No. 3,530,036 to Hirsch et al. and U.S. Pat. No. 3,530,497 to Hirsch et al. are similar to Farnsworth; U.S. Pat. No. 4,233,537 to Limpaecher, which discloses electrostatic confinement of ions and magnetic confinement of electrons with multi-pole cusp reflecting walls; and U.S. Pat. No.

4,826,646 to Bussard, which is similar to Limpaecher and involves point cusps. None of these patents consider electrostatic confinement of electrons and magnetic confinement of ions. Although there have been many research projects on electrostatic confinement of ions, none of them have succeeded in establishing the required electrostatic fields when the ions have the required density for a fusion reactor. Lastly, none of the patents cited above discuss a field reversed configuration magnetic topology.

**[0015]** The field reversed configuration (FRC) was discovered accidentally around 1960 at the Naval Research Laboratory during theta pinch experiments. A typical FRC topology, wherein the internal magnetic field reverses direction, is illustrated in FIG. 2 and FIG. 4, and particle orbits in a FRC are shown in FIG. 5 and FIG. 8. Regarding the FRC, many research programs have been supported in the United States and Japan. There is a comprehensive review paper on the theory and experiments of FRC research from 1960-1988. See M. Tuszewski, 28 *Nuclear Fusion* 2033, (1988). A white paper on FRC development describes the research in 1996 and recommendations for future research. See L. C. Steinhauer et al., 30 *Fusion Technology* 116 (1996). To this date, in FRC experiments the FRC has been formed with the theta pinch method. A consequence of this formation method is that the ions and electrons each carry half the current, which results in a negligible electrostatic field in the plasma and no electrostatic confinement. The ions and electrons in these FRCs were contained magnetically. In almost all FRC experiments, anomalous transport has been assumed. See, e.g., Tuszewski, beginning of section 1.5.2, at page 2072.

**[0016]** Thus, it is desirable to provide a fusion system having a containment system that tends to substantially reduce or eliminate anomalous transport of ions and electrons and an energy conversion system that converts the energy of fusion products to electricity with high efficiency.

#### SUMMARY OF THE INVENTION

**[0017]** The present invention is directed to a system that facilitates controlled fusion in a magnetic field having a field-reversed topology and the direct conversion of fusion product energies to electric power. The system, referred to herein as a plasma-electric power generation (PEG) system, preferably includes a fusion reactor having a containment system that tends to substantially reduce or eliminate anomalous transport of ions and electrons. In addition, the PEG system includes an energy conversion system coupled to the reactor that directly converts fusion product energies to electricity with high efficiency.

**[0018]** In one innovative aspect of the present invention, anomalous transport for both ions and electrons tends to be substantially reduced or eliminated. The anomalous transport of ions tends to be avoided by magnetically confining the ions in a magnetic field of field reversed configuration (FRC). For electrons, the anomalous transport of energy is avoided by tuning an externally applied magnetic field to develop a strong electric field, which confines the electrons electrostatically in a deep potential well. As a result, fusion fuel plasmas that can be used with the present confinement apparatus and process are not limited to neutronic fuels, but also advantageously include advanced or aneutronic fuels. For aneutronic fuels, fusion reaction energy is almost entirely in the form of charged particles, i.e., energetic ions, that can be manipulated in a magnetic field and, depending on the fuel, cause little or no radioactivity.

[0019] In another innovative aspect of the present invention, a direct energy conversion system is used to convert the kinetic energy of the fusion products directly into electric power by slowing down the charged particles through an electromagnetic field. Advantageously, the direct energy conversion system of the present invention has the efficiencies, particle-energy tolerances and electronic ability to convert the frequency and phase of the fusion output power of about 5 MHz to match the frequency of an external 60 Hertz power grid.

[0020] In a preferred embodiment, the fusion reactor's plasma containment system comprises a chamber, a magnetic field generator for applying a magnetic field in a direction substantially along a principle axis, and an annular plasma layer that comprises a circulating beam of ions. Ions of the annular plasma beam layer are substantially contained within the chamber magnetically in orbits and the electrons are substantially contained in an electrostatic energy well. In one aspect of one preferred embodiment a magnetic field generator comprises a current coil. Preferably, the system further comprises mirror coils near the ends of the chamber that increase the magnitude of the applied magnetic field at the ends of the chamber. The system may also comprise a beam injector for injecting a neutralized ion beam into the applied magnetic field, wherein the beam enters an orbit due to the force caused by the applied magnetic field. In another aspect of the preferred embodiments, the system forms a magnetic field having a topology of a field reversed configuration.

[0021] In another preferred embodiment, the energy conversion system comprises inverse cyclotron converters (ICC) coupled to opposing ends of the fusion reactor. The ICC have a hollow cylinder-like geometry formed from multiple, preferably four or more equal, semi-cylindrical electrodes with small, straight gaps extending there between. In operation, an oscillating potential is applied to the electrodes in an alternating fashion. The electric field  $E$  within the ICC has a multi-pole structure and vanishes on the symmetry axes and increases linearly with radius; the peak value being at the gap.

[0022] In addition, the ICC includes a magnetic field generator for applying a uniform uni-directional magnetic field in a direction substantially opposite to that of the fusion reactor's containment system. At an end furthest from the fusion reactor power core the ICC includes an ion collector. In between the power core and the ICC is a symmetric magnetic cusp wherein the magnetic field of the containment system merges with the magnetic field of the ICC. An annular shaped electron collector is positioned about the magnetic cusp and electrically coupled to the ion collector.

[0023] In yet another preferred embodiment, product nuclei and charge-neutralizing electrons emerge as annular beams from both ends of the reactor power core with a density at which the magnetic cusp separates electrons and ions due to their energy differences. The electrons follow magnetic field lines to the electron collector and the ions pass through the cusp where the ion trajectories are modified to follow a substantially helical path along the length of the ICC. Energy is removed from the ions as they spiral past the electrodes, which are connected to a resonant circuit. The loss of perpendicular energy tends to be greatest for the highest energy ions that initially circulate close to the electrodes, where the electric field is strongest.

[0024] Other aspects and features of the present invention will become apparent from consideration of the following description taken in conjunction with the accompanying drawings.

#### BRIEF DESCRIPTION OF THE DRAWINGS

[0025] Preferred embodiments are illustrated by way of example, and not by way of limitation, in the figures of the accompanying drawings, in which like reference numerals refer to like components.

[0026] FIG. 1 shows an exemplary confinement chamber of the present invention.

[0027] FIG. 2 shows the magnetic field of a FRC.

[0028] FIGS. 3A and 3B show, respectively, the diamagnetic and the counterdiamagnetic direction in a FRC.

[0029] FIG. 4 shows the colliding beam system of the present invention.

[0030] FIG. 5 shows a betatron orbit.

[0031] FIGS. 6A and 6B show, respectively, the magnetic field and the direction of the gradient drift in a FRC.

[0032] FIGS. 7A and 7B show, respectively, the electric field and the direction of the  $\vec{E} \times \vec{B}$  drift in a FRC.

[0033] FIGS. 8A, 8B and 8C show ion drift orbits.

[0034] FIGS. 9A and 9B show the Lorentz force at the ends of a FRC.

[0035] FIGS. 10A and 10B show the tuning of the electric field and the electric potential in the colliding beam system.

[0036] FIG. 11 shows a Maxwell distribution.

[0037] FIGS. 12A and 12B show transitions from betatron orbits to drift orbits due to large-angle, ion-ion collisions.

[0038] FIG. 13 show A, B, C and D betatron orbits when small-angle, electron-ion collisions are considered.

[0039] FIG. 14 shows a neutralized ion beam as it is electrically polarized before entering a confining chamber.

[0040] FIG. 15 is a head-on view of a neutralized ion beam as it contacts plasma in a confining chamber.

[0041] FIG. 16 is a side view schematic of a confining chamber according to a preferred embodiment of a start-up procedure.

[0042] FIG. 17 is a side view schematic of a confining chamber according to another preferred embodiment of a start-up procedure.

[0043] FIG. 18 shows traces of B-dot probe indicating the formation of a FRC.

[0044] FIG. 19A shows a partial plasma-electric power generation system comprising a colliding beam fusion reactor coupled to an inverse cyclotron direct energy converter.

[0045] FIG. 19B shows an end view of the inverse cyclotron converter in FIG. 19A.

[0046] FIG. 19C shows an orbit of an ion in the inverse cyclotron converter.

[0047] FIG. 20A shows a partial plasma electric power generation system comprising a colliding beam fusion reactor coupled to an alternate embodiment of the inverse cyclotron converter.

[0048] FIG. 20B shows an end view of the inverse cyclotron converter in FIG. 20A.

[0049] FIG. 21A shows a particle orbit inside a conventional cyclotron.

[0050] FIG. 21B shows an oscillating electric field.

[0051] FIG. 21C shows the changing energy of an accelerating particle.

[0052] FIG. 22 shows an azimuthal electric field at gaps between the electrodes of the ICC that is experienced by an ion with angular velocity.

[0053] FIG. 23 shows a focusing quadrupole doublet lens.

[0054] FIGS. 24A and 24B show auxiliary magnetic-field-coil system.

[0055] FIG. 25 shows a 100 MW reactor.

[0056] FIG. 26 shows reactor support equipment.

[0057] FIG. 27 shows a plasma-thrust propulsion system.

#### DETAILED DESCRIPTION OF THE PREFERRED EMBODIMENTS

[0058] As illustrated in the figures, a plasma-electric power generation system of the present invention preferably includes a colliding beam fusion reactor coupled to a direct energy conversion system. As alluded to above, an ideal fusion reactor solves the problem of anomalous transport for both ions and electrons. The solution to the problem of anomalous transport found herein makes use of a containment system with a magnetic field having a field reversed configuration (FRC). The anomalous transport of ions is avoided by magnetic confinement in the FRC in such a way that the majority of the ions have large, non-adiabatic orbits, making them insensitive to short-wavelength fluctuations that cause anomalous transport of adiabatic ions. In particular, the existence of a region in the FRC where the magnetic field vanishes makes it possible to have a plasma comprising a majority of non-adiabatic ions. For electrons, the anomalous transport of energy is avoided by tuning the externally applied magnetic field to develop a strong electric field, which confines them electrostatically in a deep potential well.

[0059] Fusion fuel plasmas that can be used with the present confinement apparatus and process are not limited to neutronic fuels such as D-D (Deuterium-Deuterium) or D-T (Deuterium-Tritium), but also advantageously include advanced or aneutronic fuels such as D-He<sup>3</sup> (Deuterium-helium-3) or p-B<sup>11</sup> (hydrogen-Boron-11). (For a discussion of advanced fuels, see R. Feldbacher & M. Heindler, *Nuclear Instruments and Methods in Physics Research*, A271 (1988) JJ-64 (North Holland Amsterdam).) For such aneutronic fuels, the fusion reaction energy is almost entirely in the form of charged particles, i.e., energetic ions, that can be manipulated in a magnetic field and, depending on the fuel, cause little or no radioactivity. The D-He<sup>3</sup> reaction produces an H ion and an He<sup>4</sup> ion with 18.2 MeV energy while the p-B<sup>11</sup> reaction produces three He<sup>4</sup> ions and 8.7 MeV energy. Based on theoretical modeling for a fusion device utilizing aneutronic fuels, the output energy conversion efficiency may be as high as about 90%, as described by K. Yoshikawa, T. Noma and Y. Yamamoto in *Fusion Technology*, 19, 870 (1991), for example. Such efficiencies dramatically advance the prospects for aneutronic fusion, in a scalable (1-1000 MW), compact, low-cost configuration.

[0060] In a direct energy conversion process of the present invention, the charged particles of fusion products can be slowed down and their kinetic energy converted directly to electricity. Advantageously, the direct energy conversion system of the present invention has the efficiencies, particle-energy tolerances and electronic ability to convert the fre-

quency and phase of the fusion output power of about 5 MHz to match the frequency and phase of an external 60 Hertz power grid.

#### Fusion Containment System

[0061] FIG. 1 illustrates a preferred embodiment of a containment system 300 according to the present invention. The containment system 300 comprises a chamber wall 305 that defines therein a confining chamber 310. Preferably, the chamber 310 is cylindrical in shape, with principle axis 315 along the center of the chamber 310. For application of this containment system 300 to a fusion reactor, it is necessary to create a vacuum or near vacuum inside the chamber 310. Concentric with the principle axis 315 is a betatron flux coil 320, located within the chamber 310. The betatron flux coil 320 comprises an electrical current carrying medium adapted to direct current around a long coil, as shown, which preferably comprises parallel windings of multiple separate coils and, most preferably, parallel windings of about four separate coils, to form a long coil. Persons skilled in the art will appreciate that current through the betatron coil 320 will result in a magnetic field inside the betatron coil 320, substantially in the direction of the principle axis 315.

[0062] Around the outside of the chamber wall 305 is an outer coil 325. The outer coil 325 produce a relatively constant magnetic field having flux substantially parallel with principle axis 315. This magnetic field is azimuthally symmetrical. The approximation that the magnetic field due to the outer coil 325 is constant and parallel to axis 315 is most valid away from the ends of the chamber 310. At each end of the chamber 310 is a mirror coil 330. The mirror coils 330 are adapted to produce an increased magnetic field inside the chamber 310 at each end, thus bending the magnetic field lines inward at each end. (See FIGS. 2 and 4.) As explained, this bending inward of the field lines helps to contain the plasma 335 in a containment region within the chamber 310 generally between the mirror coils 330 by pushing it away from the ends where it can escape the containment system 300. The mirror coils 330 can be adapted to produce an increased magnetic field at the ends by a variety of methods known in the art, including increasing the number of windings in the mirror coils 330, increasing the current through the mirror coils 330, or overlapping the mirror coils 330 with the outer coil 325.

[0063] The outer coil 325 and mirror coils 330 are shown in FIG. 1 implemented outside the chamber wall 305; however, they may be inside the chamber 310. In cases where the chamber wall 305 is constructed of a conductive material such as metal, it may be advantageous to place the coils 325, 330 inside the chamber wall 305 because the time that it takes for the magnetic field to diffuse through the wall 305 may be relatively large and thus cause the system 300 to react sluggishly. Similarly, the chamber 310 may be of the shape of a hollow cylinder, the chamber wall 305 forming a long, annular ring. In such a case, the betatron flux coil 320 could be implemented outside of the chamber wall 305 in the center of that annular ring. Preferably, the inner wall forming the center of the annular ring may comprise a non-conducting material such as glass. As will become apparent, the chamber 310 must be of sufficient size and shape to allow the circulating plasma beam or layer 335 to rotate around the principle axis 315 at a given radius.

[0064] The chamber wall 305 may be formed of a material having a high magnetic permeability, such as steel. In such a

case, the chamber wall **305**, due to induced countercurrents in the material, helps to keep the magnetic flux from escaping the chamber **310**, “compressing” it. If the chamber wall were to be made of a material having low magnetic permeability, such as plexiglass, another device for containing the magnetic flux would be necessary. In such a case, a series of closed-loop, flat metal rings could be provided. These rings, known in the art as flux delimiters, would be provided within the outer coils **325** but outside the circulating plasma beam **335**. Further, these flux delimiters could be passive or active, wherein the active flux delimiters would be driven with a predetermined current to greater facilitate the containment of magnetic flux within the chamber **310**. Alternatively, the outer coils **325** themselves could serve as flux delimiters.

[0065] As explained in further detail below, a circulating plasma beam **335**, comprising charged particles, may be contained within the chamber **310** by the Lorentz force caused by the magnetic field due to the outer coil **325**. As such, the ions in the plasma beam **335** are magnetically contained in large betatron orbits about the flux lines from the outer coil **325**, which are parallel to the principle axis **315**. One or more beam injection ports **340** are also provided for adding plasma ions to the circulating plasma beam **335** in the chamber **310**. In a preferred embodiment, the injector ports **340** are adapted to inject an ion beam at about the same radial position from the principle axis **315** where the circulating plasma beam **335** is contained (i.e., around a null surface described below). Further, the injector ports **340** are adapted to inject ion beams **350** (See FIG. 16) tangent to and in the direction of the betatron orbit of the contained plasma beam **335**.

[0066] Also provided are one or more background plasma sources **345** for injecting a cloud of non-energetic plasma into the chamber **310**. In a preferred embodiment, the background plasma sources **345** are adapted to direct plasma **335** toward the axial center of the chamber **310**. It has been found that directing the plasma this way helps to better contain the plasma **335** and leads to a higher density of plasma **335** in the containment region within the chamber **310**.

#### Charged Particles in a FRC

[0067] FIG. 2 shows a magnetic field of a FRC **70**. The system has cylindrical symmetry with respect to its axis **78**. In the FRC, there are two regions of magnetic field lines: open **80** and closed **82**. The surface dividing the two regions is called the separatrix **84**. The FRC forms a cylindrical null surface **86** in which the magnetic field vanishes. In the central part **88** of the FRC the magnetic field does not change appreciably in the axial direction. At the ends **90**, the magnetic field does change appreciably in the axial direction. The magnetic field along the center axis **78** reverses direction in the FRC, which gives rise to the term “Reversed” in Field Reversed Configuration (FRC).

[0068] In FIG. 3A, the magnetic field outside of the null surface **94** is in a first direction **96**. The magnetic field inside the null surface **94** is in a second direction **98** opposite the first. If an ion moves in the direction **100**, the Lorentz force **30** acting on it points towards the null surface **94**. This is easily appreciated by applying the right-hand rule. For particles moving in the diamagnetic direction **102**, the Lorentz force always points toward the null surface **94**. This phenomenon gives rise to a particle orbit called betatron orbit, to be described below.

[0069] FIG. 3B shows an ion moving in the counterdiamagnetic direction **104**. The Lorentz force in this case points away

from the null surface **94**. This phenomenon gives rise to a type of orbit called a drift orbit, to be described below. The diamagnetic direction for ions is counterdiamagnetic for electrons, and vice versa.

[0070] FIG. 4 shows a ring or annular layer of plasma **106** rotating in the ions’ diamagnetic direction **102**. The ring **106** is located around the null surface **86**. The magnetic field **108** created by the annular plasma layer **106**, in combination with an externally applied magnetic field **110**, forms a magnetic field having the topology of a FRC (The topology is shown in FIG. 2).

[0071] The ion beam that forms the plasma layer **106** has a temperature; therefore, the velocities of the ions form a Maxwell distribution in a frame rotating at the average angular velocity of the ion beam. Collisions between ions of different velocities lead to fusion reactions. For this reason, the plasma beam layer or power core **106** is called a colliding beam system.

[0072] FIG. 5 shows the main type of ion orbits in a colliding beam system, called a betatron orbit **112**. A betatron orbit **112** can be expressed as a sine wave centered on the null circle **114**. As explained above, the magnetic field on the null circle **114** vanishes. The plane of the orbit **112** is perpendicular to the axis **78** of the FRC. Ions in this orbit **112** move in their diamagnetic direction **102** from a starting point **116**. An ion in a betatron orbit has two motions: an oscillation in the radial direction (perpendicular to the null circle **114**), and a translation along the null circle **114**.

[0073] FIG. 6A is a graph of the magnetic field **118** in a FRC. The horizontal axis of the graph represents the distance in centimeters from the FRC axis **78**. The magnetic field is in kilogauss. As the graph depicts, the magnetic field **118** vanishes at the null circle radius **120**.

[0074] As shown in FIG. 6B, a particle moving near the null circle will see a gradient **126** of the magnetic field pointing away from the null surface **86**. The magnetic field outside the null circle is in a first direction **122**, while the magnetic field inside the null circle is in a second direction **124** opposite to the first. The direction of a gradient drift is given by the cross

product  $\vec{B} \times \nabla B$ , where  $\nabla B$  is the gradient of the magnetic field; thus, it can be appreciated by applying the right-hand rule that the direction of the gradient drift is in the counterdiamagnetic direction, whether the ion is outside or inside the null circle **128**.

[0075] FIG. 7A is a graph of the electric field **130** in a FRC. The horizontal axis of the graph represents the distance in centimeters from the FRC axis **78**. The electric field is in volts/cm. As the graph depicts, the electric field **130** vanishes close to the null circle radius **120**.

[0076] As shown in FIG. 7B, the electric field for ions is deconfining; it points in directions **132**, **134** away from the null surface **86**. The magnetic field, as before, is in opposite directions **122**, **124** inside and outside of the null surface **86**. It can be appreciated by applying the right-hand rule that the direction of the  $\vec{E} \times \vec{B}$  drift is in the diamagnetic direction **102**, whether the ion is outside or inside the null surface **136**.

[0077] FIGS. 8A and 8B show another type of common orbit in a FRC, called a drift orbit **138**. Drift orbits **138** can be outside of the null surface **114**, as shown in FIG. 8A, or inside it, as shown in FIG. 8B. Drift orbits **138** rotate in the diamagnetic direction if the  $\vec{E} \times \vec{B}$  drift dominates or in the counterdiamagnetic direction if the gradient drift dominates. The

drift orbits **138** shown in FIGS. **8A** and **8B** rotate in the diamagnetic direction **102** from starting point **116**.

[**0078**] A drift orbit, as shown in FIG. **8C**, can be thought of as a small circle rolling over a relatively bigger circle. The small circle **142** spins around its axis in the sense **144**. It also rolls over the big circle **146** in the direction **102**. The point **140** will trace in space a path similar to **138**.

[**0079**] FIGS. **9A** and **9B** show the direction of the Lorentz force at the ends of a FRC **151**. In FIG. **9A**, an ion is shown moving in the diamagnetic direction **102** with a velocity **148** in a magnetic field **150**. It can be appreciated by applying the right-hand rule that the Lorentz force **152** tends to push the ion back into the region of closed field lines. In this case, therefore, the Lorentz force **152** is confining for the ions. In FIG. **9B**, an ion is shown moving in the counterdiamagnetic direction with a velocity **148** in a magnetic field **150**. It can be appreciated by applying the right-hand rule that the Lorentz force **152** tends to push the ion into the region of open field lines. In this case, therefore, the Lorentz force **152** is deconfining for the ions.

[**0080**] Magnetic and Electrostatic Confinement in a FRC

[**0081**] A plasma layer **106** (see FIG. **4**) can be formed in a FRC by injecting energetic ion beams around the null surface **86** in the diamagnetic direction **102** of ions. (A detailed discussion of different methods of forming the FRC and plasma ring follows below.) In the circulating plasma layer **106**, most of the ions have betatron orbits **112** (see FIG. **5**), are energetic, and are non-adiabatic; thus, they are insensitive to short-wavelength fluctuations that cause anomalous transport.

[**0082**] In a plasma layer **106** formed in a FRC and under equilibrium conditions, the conservation of momentum imposes a relation between the angular velocity of ions  $\omega_i$  and the angular velocity of electrons  $\omega_e$ . The relation is

$$\omega_e = \omega_i \left[ 1 - \frac{\omega_i}{\Omega_0} \right], \text{ where } \Omega_0 = \frac{ZeB_0}{m_i c}. \quad (1)$$

In Eq. 1,  $Z$  is the ion atomic number,  $m_i$  is the ion mass,  $e$  is the electron charge,  $B_0$  is the magnitude of the applied magnetic field, and  $c$  is the speed of light. There are three free parameters in this relation: the applied magnetic field  $B_0$ , the electron angular velocity  $\omega_e$ , and the ion angular velocity  $\omega_i$ . If two of them are known, the third can be determined from Eq. 1.

[**0083**] Because the plasma layer **106** is formed by injecting ion beams into the FRC, the angular velocity of ions  $\omega_i$  is determined by the injection kinetic energy of the beam  $W_i$ , which is given by

$$W_i = \frac{1}{2} m_i V_i^2 = \frac{1}{2} m_i (\omega_i r_0)^2 \quad (2)$$

Here,  $V_i = \omega_i r_0$ , where  $V_i$  is the injection velocity of ions,  $\omega_i$  is the cyclotron frequency of ions, and  $r_0$  is the radius of the null surface **86**. The kinetic energy of electrons in the beam has been ignored because the electron mass  $m_e$  is much smaller than the ion mass  $m_i$ .

[**0084**] For a fixed injection velocity of the beam (fixed  $\omega_i$ ), the applied magnetic field  $B_0$  can be tuned so that different values of  $W_e$  are obtainable. As will be shown, tuning the external magnetic field  $B_0$  also gives rise to different values of

the electrostatic field inside the plasma layer. This feature of the invention is illustrated in FIGS. **10A** and **10B**. FIG. **10A** shows three plots of the electric field (in volts/cm) obtained for the same injection velocity,  $\omega_i = 1.35 \times 10^7 \text{ s}^{-1}$ , but for three different values of the applied magnetic field  $B_0$ :

Plot	Applied magnetic field ( $B_0$ )	electron angular velocity ( $\omega_e$ )
154	$B_0 = 2.77 \text{ kG}$	$\omega_e = 0$
156	$B_0 = 5.15 \text{ kG}$	$\omega_e = 0.625 \times 10^7 \text{ s}^{-1}$
158	$B_0 = 15.5 \text{ kG}$	$\omega_e = 1.11 \times 10^7 \text{ s}^{-1}$

The values of  $\omega_e$  in the table above were determined according to Eq. 1. One can appreciate that  $\omega_e > 0$  means that  $\Omega_0 > \omega_i$  in Eq. 1, so that electrons rotate in their counterdiamagnetic direction. FIG. **10B** shows the electric potential (in volts) for the same set of values of  $B_0$  and  $\omega_e$ . The horizontal axis, in FIGS. **10A** and **10B**, represents the distance from the FRC axis **78**, shown in the graph in centimeters. The electric field and electric potential depend strongly on  $\omega_e$ .

[**0085**] The above results can be explained on simple physical grounds. When the ions rotate in the diamagnetic direction, the ions are confined magnetically by the Lorentz force. This was shown in FIG. **3A**. For electrons, rotating in the same direction as the ions, the Lorentz force is in the opposite direction, so that electrons would not be confined. The electrons leave the plasma and, as a result, a surplus of positive charge is created. This sets up an electric field that prevents other electrons from leaving the plasma. The direction and the magnitude of this electric field, in equilibrium, is determined by the conservation of momentum.

[**0086**] The electrostatic field plays an essential role on the transport of both electrons and ions. Accordingly, an important aspect of this invention is that a strong electrostatic field is created inside the plasma layer **106**, the magnitude of this electrostatic field is controlled by the value of the applied magnetic field  $B_0$  which can be easily adjusted.

[**0087**] As explained, the electrostatic field is confining for electrons if  $\omega_e > 0$ . As shown in FIG. **10B**, the depth of the well can be increased by tuning the applied magnetic field  $B_0$ . Except for a very narrow region near the null circle, the electrons always have a small gyroradius. Therefore, electrons respond to short-wavelength fluctuations with an anomalously fast diffusion rate. This diffusion, in fact, helps maintain the potential well once the fusion reaction occurs. The fusion product ions, being of much higher energy, leave the plasma. To maintain charge quasi-neutrality, the fusion products must pull electrons out of the plasma with them, mainly taking the electrons from the surface of the plasma layer. The density of electrons at the surface of the plasma is very low, and the electrons that leave the plasma with the fusion products must be replaced; otherwise, the potential well would disappear.

[**0088**] FIG. **11** shows a Maxwellian distribution **162** of electrons. Only very energetic electrons from the tail **160** of the Maxwell distribution can reach the surface of the plasma and leave with fusion ions. The tail **160** of the distribution **162** is thus continuously created by electron-electron collisions in the region of high density near the null surface. The energetic electrons still have a small gyroradius, so that anomalous diffusion permits them to reach the surface fast enough to accommodate the departing fusion product ions. The ener-

getic electrons lose their energy ascending the potential well and leave with very little energy. Although the electrons can cross the magnetic field rapidly, due to anomalous transport, anomalous energy losses tend to be avoided because little energy is transported.

[0089] Another consequence of the potential well is a strong cooling mechanism for electrons that is similar to evaporative cooling. For example, for water to evaporate, it must be supplied the latent heat of vaporization. This heat is supplied by the remaining liquid water and the surrounding medium, which then thermalize rapidly to a lower temperature faster than the heat transport processes can replace the energy. Similarly, for electrons, the potential well depth is equivalent to water's latent heat of vaporization. The electrons supply the energy required to ascend the potential well by the thermalization process that re-supplies the energy of the Maxwell tail so that the electrons can escape. The thermalization process thus results in a lower electron temperature, as it is much faster than any heating process. Because of the mass difference between electrons and protons, the energy transfer time from protons is about 1800 times less than the electron thermalization time. This cooling mechanism also reduces the radiation loss of electrons. This is particularly important for advanced fuels, where radiation losses are enhanced by fuel ions with an atomic number  $Z$  greater than 1;  $Z > 1$ .

[0090] The electrostatic field also affects ion transport. The majority of particle orbits in the plasma layer 106 are betatron orbits 112. Large-angle collisions, that is, collisions with scattering angles between  $90^\circ$  and  $180^\circ$ , can change a betatron orbit to a drift orbit. As described above, the direction of rotation of the drift orbit is determined by a competition between the  $\vec{E} \times \vec{A}$  drift and the gradient drift. If the  $\vec{E} \times \vec{A}$  drift dominates, the drift orbit rotates in the diamagnetic direction. If the gradient drift dominates, the drift orbit rotates in the counterdiamagnetic direction. This is shown in FIGS. 12A and 12B. FIG. 12A shows a transition from a betatron orbit to a drift orbit due to a  $180^\circ$  collision, which occurs at the point 172. The drift orbit continues to rotate in the diamagnetic direction because the  $\vec{E} \times \vec{B}$  drift dominates. FIG. 12B shows another  $180^\circ$  collision, but in this case the electrostatic field is weak and the gradient drift dominates. The drift orbit thus rotates in the counterdiamagnetic direction.

[0091] The direction of rotation of the drift orbit determines whether it is confined or not. A particle moving in a drift orbit will also have a velocity parallel to the FRC axis. The time it takes the particle to go from one end of the FRC to the other, as a result of its parallel motion, is called transit time; thus, the drift orbits reach an end of the FRC in a time of the order of the transit time. As shown in connection with FIG. 9A, the Lorentz force at the ends of the FRC is confining only for drift orbits rotating in the diamagnetic direction. After a transit time, therefore, ions in drift orbits rotating in the counterdiamagnetic direction are lost.

[0092] This phenomenon accounts for a loss mechanism for ions, which is expected to have existed in all FRC experiments. In fact, in these experiments, the ions carried half of the current and the electrons carried the other half. In these conditions the electric field inside the plasma was negligible, and the gradient drift always dominated the  $\vec{E} \times \vec{B}$  drift. Hence, all the drift orbits produced by large-angle collisions

were lost after a transit time. These experiments reported ion diffusion rates that were faster than those predicted by classical diffusion estimates.

[0093] If there is a strong electrostatic field, the  $\vec{E} \times \vec{B}$  drift dominates the gradient drift, and the drift orbits rotate in the diamagnetic direction. This was shown above in connection with FIG. 12A. When these orbits reach the ends of the FRC, they are reflected back into the region of closed field lines by the Lorentz force; thus, they remain confined in the system.

[0094] The electrostatic fields in the colliding beam system may be strong enough, so that the  $\vec{E} \times \vec{B}$  drift dominates the gradient drift. Thus, the electrostatic field of the system would avoid ion transport by eliminating this ion loss mechanism, which is similar to a loss cone in a mirror device.

[0095] Another aspect of ion diffusion can be appreciated by considering the effect of small-angle, electron-ion collisions on betatron orbits. FIG. 13A shows a betatron orbit 112; FIG. 13B shows the same orbit 112 when small-angle electron-ion collisions are considered 174; FIG. 13C shows the orbit of FIG. 13B followed for a time that is longer by a factor of ten 176; and FIG. 13D shows the orbit of FIG. 13B followed for a time longer by a factor of twenty 178. It can be seen that the topology of betatron orbits does not change due to small-angle, electron-ion collisions; however, the amplitude of their radial oscillations grows with time. In fact, the orbits shown in FIGS. 13A to 13D fatten out with time, which indicates classical diffusion.

#### Formation of the FRC

[0096] Conventional procedures used to form a FRC primarily employ the theta pinch-field reversal procedure. In this conventional method, a bias magnetic field is applied by external coils surrounding a neutral gas back-filled chamber. Once this has occurred, the gas is ionized and the bias magnetic field is frozen in the plasma. Next, the current in the external coils is rapidly reversed and the oppositely oriented magnetic field lines connect with the previously frozen lines to form the closed topology of the FRC (see FIG. 2). This formation process is largely empirical and there exists almost no means of controlling the formation of the FRC. The method has poor reproducibility and no tuning capability as a result.

[0097] In contrast, the FRC formation methods of the present invention allow for ample control and provide a much more transparent and reproducible process. In fact, the FRC formed by the methods of the present invention can be tuned and its shape as well as other properties can be directly influenced by manipulation of the magnetic field applied by the outer field coils 325. Formation of the FRC by methods of the present inventions also results in the formation of the electric field and potential well in the manner described in detail above. Moreover, the present methods can be easily extended to accelerate the FRC to reactor level parameters and high-energy fuel currents, and advantageously enables the classical confinement of the ions. Furthermore, the technique can be employed in a compact device and is very robust as well as easy to implement—all highly desirable characteristics for reactor systems.

[0098] In the present methods, FRC formation relates to the circulating plasma beam 335. It can be appreciated that the circulating plasma beam 335, because it is a current, creates a poloidal magnetic field, as would an electrical current in a circular wire. Inside the circulating plasma beam 335, the



magnetic self-field that it induces opposes the externally applied magnetic field due to the outer coil **325**. Outside the plasma beam **335**, the magnetic self-field is in the same direction as the applied magnetic field. When the plasma ion current is sufficiently large, the self-field overcomes the applied field, and the magnetic field reverses inside the circulating plasma beam **335**, thereby forming the FRC topology as shown in FIGS. **2** and **4**.

**[0099]** The requirements for field reversal can be estimated with a simple model. Consider an electric current  $I_p$  carried by a ring of major radius  $r_0$  and minor radius  $a \ll r_0$ . The magnetic field at the center of the ring normal to the ring is  $B_p = 2\pi I_p / (cr_0)$ . Assume that the ring current  $I_p = N_p e (\Omega_0 / 2\pi)$  is carried by  $N_p$  ions that have an angular velocity  $\Omega_0$ . For a single ion circulating at radius  $r_0 = V_0 / \Omega_0$ ,  $\Omega_0 = eB_0 / m_i c$  is the cyclotron frequency for an external magnetic field  $B_0$ . Assume  $V_0$  is the average velocity of the beam ions. Field reversal is defined as

$$B_p = \frac{N_p e \Omega_0}{r_0 c} \geq 2B_0, \quad (3)$$

which implies that  $N_p > 2 r_0 / \alpha_i$ , and

$$I_p \geq \frac{eV_0}{\pi \alpha_i}, \quad (4)$$

where  $\alpha_i = e^2 / m_i c^2 = 1.57 \times 10^{-16}$  cm and the ion beam energy is  $\frac{1}{2} m_i V_0^2$ . In the one-dimensional model, the magnetic field from the plasma current is  $B_p = (2\pi/c) i_p$ , where  $i_p$  is current per unit of length. The field reversal requirement is  $i_p > eV_0 / \pi \alpha_i = 0.225$  kA/cm, where  $B_0 = 69.3$  G and  $\frac{1}{2} m_i V_0^2 = 100$  eV. For a model with periodic rings and  $B_z$  is averaged over the axial coordinate  $\langle B_z \rangle = (2\pi/c) (I_p / s)$  ( $s$  is the ring spacing), if  $s = r_0$ , this model would have the same average magnetic field as the one dimensional model with  $i_p = I_p / s$ .

**[0100]** Combined Beam/Betatron Formation Technique

**[0101]** A preferred method of forming a FRC within the confinement system **300** described above is herein termed the combined beam/betatron technique. This approach combines low energy beams of plasma ions with betatron acceleration using the betatron flux coil **320**.

**[0102]** The first step in this method is to inject a substantially annular cloud layer of background plasma in the chamber **310** using the background plasma sources **345**. Outer coil **325** produces a magnetic field inside the chamber **310**, which magnetizes the background plasma. At short intervals, low energy ion beams are injected into the chamber **310** through the injector ports **340** substantially transverse to the externally applied magnetic field within the chamber **310**. As explained above, the ion beams are trapped within the chamber **310** in large betatron orbits by this magnetic field. The ion beams may be generated by an ion accelerator, such as an accelerator comprising an ion diode and a Marx generator. (see R. B. Miller, *An Introduction to the Physics of Intense Charged Particle Beams*, (1982)). As one of skill in the art can appreciate, the externally applied magnetic field will exert a Lorentz force on the injected ion beam as soon as it enters the chamber **310**; however, it is desired that the beam not deflect, and thus not enter a betatron orbit, until the ion beam reaches the circulating plasma beam **335**. To solve this problem, the

ion beams are neutralized with electrons and directed through a substantially constant unidirectional magnetic field before entering the chamber **310**. As illustrated in FIG. **14**, when the ion beam **350** is directed through an appropriate magnetic field, the positively charged ions and negatively charged electrons separate. The ion beam **350** thus acquires an electric self-polarization due to the magnetic field. This magnetic field may be produced by, e.g., a permanent magnet or by an electromagnet along the path of the ion beam. When subsequently introduced into the confinement chamber **310**, the resultant electric field balances the magnetic force on the beam particles, allowing the ion beam to drift undeflected. FIG. **15** shows a head-on view of the ion beam **350** as it contacts the plasma **335**. As depicted, electrons from the plasma **335** travel along magnetic field lines into or out of the beam **350**, which thereby drains the beam's electric polarization. When the beam is no longer electrically polarized, the beam joins the circulating plasma beam **335** in a betatron orbit around the principle axis **315**, as shown in FIG. **1** (see also FIG. **4**).

**[0103]** When the plasma beam **335** travels in its betatron orbit, the moving ions comprise a current, which in turn gives rise to a poloidal magnetic self-field. To produce the FRC topology within the chamber **310**, it is necessary to increase the velocity of the plasma beam **335**, thus increasing the magnitude of the magnetic self-field that the plasma beam **335** causes. When the magnetic self-field is large enough, the direction of the magnetic field at radial distances from the axis **315** within the plasma beam **335** reverses, giving rise to a FRC. (See FIGS. **2** and **4**). It can be appreciated that, to maintain the radial distance of the circulating plasma beam **335** in the betatron orbit, it is necessary to increase the applied magnetic field from the outer coil **325** as the plasma beam **335** increases in velocity. A control system is thus provided for maintaining an appropriate applied magnetic field, dictated by the current through the outer coil **325**. Alternatively, a second outer coil may be used to provide the additional applied magnetic field that is required to maintain the radius of the plasma beam's orbit as it is accelerated.

**[0104]** To increase the velocity of the circulating plasma beam **335** in its orbit, the betatron flux coil **320** is provided. Referring to FIG. **16**, it can be appreciated that increasing a current through the betatron flux coil **320**, by Ampere's Law, induces an azimuthal electric field,  $E$ , inside the chamber **310**. The positively charged ions in the plasma beam **335** are accelerated by this induced electric field, leading to field reversal as described above. When ion beams are added to the circulating plasma beam **335**, as described above, the plasma beam **335** depolarizes the ion beams.

**[0105]** For field reversal, the circulating plasma beam **335** is preferably accelerated to a rotational energy of about 100 eV, and preferably in a range of about 75 eV to 125 eV. To reach fusion relevant conditions, the circulating plasma beam **335** is preferably accelerated to about 200 keV and preferably to a range of about 100 keV to 3.3 MeV.

**[0106]** FRC formation was successfully demonstrated utilizing the combined beam/betatron formation technique. The combined beam/betatron formation technique was performed experimentally in a chamber 1 m in diameter and 1.5 m in length using an externally applied magnetic field of up to 500 G, a magnetic field from the betatron flux coil **320** of up to 5 kG, and a vacuum of  $1.2 \times 10^{-5}$  torr. In the experiment, the background plasma had a density of  $10^{13}$  cm<sup>-3</sup> and the ion beam was a neutralized Hydrogen beam having a density of

$1.2 \times 10^{13} \text{ cm}^{-3}$ , a velocity of  $2 \times 10^7 \text{ cm/s}$ , and a pulse length of around  $20 \text{ } \mu\text{s}$  (at half height). Field reversal was observed.

[0107] Betatron Formation Technique

[0108] Another preferred method of forming a FRC within the confinement system **300** is herein termed the betatron formation technique. This technique is based on driving the betatron induced current directly to accelerate a circulating plasma beam **335** using the betatron flux coil **320**. A preferred embodiment of this technique uses the confinement system **300** depicted in FIG. 1, except that the injection of low energy ion beams is not necessary.

[0109] As indicated, the main component in the betatron formation technique is the betatron flux coil **320** mounted in the center and along the axis of the chamber **310**. Due to its separate parallel windings construction, the coil **320** exhibits very low inductance and, when coupled to an adequate power source, has a low LC time constant, which enables rapid ramp up of the current in the flux coil **320**.

[0110] Preferably, formation of the FRC commences by energizing the external field coils **325**, **330**. This provides an axial guide field as well as radial magnetic field components near the ends to axially confine the plasma injected into the chamber **310**. Once sufficient magnetic field is established, the background plasma sources **345** are energized from their own power supplies. Plasma emanating from the guns streams along the axial guide field and spreads slightly due to its temperature. As the plasma reaches the mid-plane of the chamber **310**, a continuous, axially extending, annular layer of cold, slowly moving plasma is established.

[0111] At this point the betatron flux coil **320** is energized. The rapidly rising current in the coil **320** causes a fast changing axial flux in the coil's interior. By virtue of inductive effects this rapid increase in axial flux causes the generation of an azimuthal electric field  $E$  (see FIG. 17), which permeates the space around the flux coil. By Maxwell's equations, this electric field  $E$  is directly proportional to the change in strength of the magnetic flux inside the coil, i.e.: a faster betatron coil current ramp-up will lead to a stronger electric field.

[0112] The inductively created electric field  $E$  couples to the charged particles in the plasma and causes a ponderomotive force, which accelerates the particles in the annular plasma layer. Electrons, by virtue of their smaller mass, are the first species to experience acceleration. The initial current formed by this process is, thus, primarily due to electrons. However, sufficient acceleration time (around hundreds of micro-seconds) will eventually also lead to ion current. Referring to FIG. 17, this electric field  $E$  accelerates the electrons and ions in opposite directions. Once both species reach their terminal velocities, current is carried about equally by ions and electrons.

[0113] As noted above, the current carried by the rotating plasma gives rise to a self magnetic field. The creation of the actual FRC topology sets in when the self magnetic field created by the current in the plasma layer becomes comparable to the applied magnetic field from the external field coils **325**, **330**. At this point magnetic reconnection occurs and the open field lines of the initial externally produced magnetic field begin to close and form the FRC flux surfaces (see FIGS. 2 and 4).

[0114] The base FRC established by this method exhibits modest magnetic field and particle energies that are typically not at reactor relevant operating parameters. However, the inductive electric acceleration field will persist, as long as the

current in the betatron flux coil **320** continues to increase at a rapid rate. The effect of this process is that the energy and total magnetic field strength of the FRC continues to grow. The extent of this process is, thus, primarily limited by the flux coil power supply, as continued delivery of current requires a massive energy storage bank. However, it is, in principal, straightforward to accelerate the system to reactor relevant conditions.

[0115] For field reversal, the circulating plasma beam **335** is preferably accelerated to a rotational energy of about 100 eV, and preferably in a range of about 75 eV to 125 eV. To reach fusion relevant conditions, the circulating plasma beam **335** is preferably accelerated to about 200 keV and preferably to a range of about 100 keV to 3.3 MeV. When ion beams are added to the circulating plasma beam **335**, as described above, the plasma beam **335** depolarizes the ion beams.

[0116] FRC formation utilizing the betatron formation technique was successfully demonstrated at the following parameter levels:

[0117] Vacuum chamber dimensions: about 1 m diameter, 1.5 m length.

[0118] Betatron coil radius of 10 cm.

[0119] Plasma orbit radius of 20 cm.

[0120] Mean external magnetic field produced in the vacuum chamber was up to 100 Gauss, with a ramp-up period of  $150 \text{ } \mu\text{s}$  and a mirror ratio of 2 to 1. (Source: Outer coils and betatron coils).

[0121] The background plasma (substantially Hydrogen gas) was characterized by a mean density of about  $10^{13} \text{ cm}^{-3}$ , kinetic temperature of less than 10 eV.

[0122] The lifetime of the configuration was limited by the total energy stored in the experiment and generally was around  $30 \text{ } \mu\text{s}$ .

[0123] The experiments proceeded by first injecting a background plasma layer by two sets of coaxial cable guns mounted in a circular fashion inside the chamber. Each collection of 8 guns was mounted on one of the two mirror coil assemblies. The guns were azimuthally spaced in an equidistant fashion and offset relative to the other set. This arrangement allowed for the guns to be fired simultaneously and thereby created an annular plasma layer.

[0124] Upon establishment of this layer, the betatron flux coil was energized. Rising current in the betatron coil windings caused an increase in flux inside the coil, which gave rise to an azimuthal electric field curling around the betatron coil. Quick ramp-up and high current in the betatron flux coil produced a strong electric field, which accelerated the annular plasma layer and thereby induced a sizeable current. Sufficiently strong plasma current produced a magnetic self-field that altered the externally supplied field and caused the creation of the field reversed configuration. Detailed measurements with B-dot loops identified the extent, strength and duration of the FRC.

[0125] An example of typical data is shown by the traces of B-dot probe signals in FIG. 18. The data curve A represents the absolute strength of the axial component of the magnetic field at the axial mid-plane (75 cm from either end plate) of the experimental chamber and at a radial position of 15 cm. The data curve B represents the absolute strength of the axial component of the magnetic field at the chamber axial mid-plane and at a radial position of 30 cm. The curve A data set, therefore, indicates magnetic field strength inside of the fuel plasma layer (between betatron coil and plasma) while the curve B data set depicts the magnetic field strength outside of

the fuel plasma layer. The data clearly indicates that the inner magnetic field reverses orientation (is negative) between about 23 and 47  $\mu\text{s}$ , while the outer field stays positive, i.e., does not reverse orientation. The time of reversal is limited by the ramp-up of current in the betatron coil. Once peak current is reached in the betatron coil, the induced current in the fuel plasma layer starts to decrease and the FRC rapidly decays. Up to now the lifetime of the FRC is limited by the energy that can be stored in the experiment. As with the injection and trapping experiments, the system can be upgraded to provide longer FRC lifetime and acceleration to reactor relevant parameters.

**[0126]** Overall, this technique not only produces a compact FRC, but it is also robust and straightforward to implement. Most importantly, the base FRC created by this method can be easily accelerated to any desired level of rotational energy and magnetic field strength. This is crucial for fusion applications and classical confinement of high-energy fuel beams.

#### Fusion

**[0127]** Significantly, these two techniques for forming a FRC inside of a containment system **300** described above, or the like, can result in plasmas having properties suitable for causing nuclear fusion therein. More particularly, the FRC formed by these methods can be accelerated to any desired level of rotational energy and magnetic field strength. This is crucial for fusion applications and classical confinement of high-energy fuel beams. In the confinement system **300**, therefore, it becomes possible to trap and confine high-energy plasma beams for sufficient periods of time to cause a fusion reaction therewith.

**[0128]** To accommodate fusion, the FRC formed by these methods is preferably accelerated to appropriate levels of rotational energy and magnetic field strength by betatron acceleration. Fusion, however, tends to require a particular set of physical conditions for any reaction to take place. In addition, to achieve efficient burn-up of the fuel and obtain a positive energy balance, the fuel has to be kept in this state substantially unchanged for prolonged periods of time. This is important, as high kinetic temperature and/or energy characterize a fusion relevant state. Creation of this state, therefore, requires sizeable input of energy, which can only be recovered if most of the fuel undergoes fusion. As a consequence, the confinement time of the fuel has to be longer than its burn time. This leads to a positive energy balance and consequently net energy output.

**[0129]** A significant advantage of the present invention is that the confinement system and plasma described herein are capable of long confinement times, i.e., confinement times that exceed fuel burn times. A typical state for fusion is, thus, characterized by the following physical conditions (which tend to vary based on fuel and operating mode):

**[0130]** Average ion temperature: in a range of about 30 to 230 keV and preferably in a range of about 80 keV to 230 keV

**[0131]** Average electron temperature: in a range of about 30 to 100 keV and preferably in a range of about 80 to 100 keV

**[0132]** Coherent energy of the fuel beams (injected ion beams and circulating plasma beam): in a range of about 100 keV to 3.3 MeV and preferably in a range of about 300 keV to 3.3 MeV.

**[0133]** Total magnetic field: in a range of about 47.5 to 120 kG and preferably in a range of about 95 to 120 kG (with the externally applied field in a range of about 2.5 to 15 kG and preferably in a range of about 5 to 15 kG).

**[0134]** Classical Confinement time: greater than the fuel burn time and preferably in a range of about 10 to 100 seconds.

**[0135]** Fuel ion density: in a range of about  $10^{14}$  to less than  $10^{16}$   $\text{cm}^{-3}$  and preferably in a range of about  $10^{14}$  to  $10^{15}$   $\text{cm}^{-3}$ .

**[0136]** Total Fusion Power: preferably in a range of about 50 to 450 kW/cm (power per cm of chamber length)

**[0137]** To accommodate the fusion state illustrated above, the FRC is preferably accelerated to a level of coherent rotational energy preferably in a range of about 100 keV to 3.3 MeV, and more preferably in a range of about 300 keV to 3.3 MeV, and a level of magnetic field strength preferably in a range of about 45 to 120 kG, and more preferably in a range of about 90 to 115 kG. At these levels, high energy ion beams can be injected into the FRC and trapped to form a plasma beam layer wherein the plasma beam ions are magnetically confined and the plasma beam electrons are electrostatically confined.

**[0138]** Preferably, the electron temperature is kept as low as practically possible to reduce the amount of bremsstrahlung radiation, which can, otherwise, lead to radiative energy losses. The electrostatic energy well of the present invention provides an effective means of accomplishing this.

**[0139]** The ion temperature is preferably kept at a level that provides for efficient burn-up since the fusion cross-section is a function of ion temperature. High direct energy of the fuel ion beams is essential to provide classical transport as discussed in this application. It also minimizes the effects of instabilities on the fuel plasma. The magnetic field is consistent with the beam rotation energy. It is partially created by the plasma beam (self-field) and in turn provides the support and force to keep the plasma beam on the desired orbit.

#### Fusion Products

**[0140]** The fusion products are born in the power core predominantly near the null surface **86** from where they emerge by diffusion towards the separatrix **84** (see FIGS. 2 and 4). This is due to collisions with electrons (as collisions with ions do not change the center of mass and therefore do not cause them to change field lines). Because of their high kinetic energy (product ions have much higher energy than the fuel ions), the fusion products can readily cross the separatrix **84**. Once they are beyond the separatrix **84**, they can leave along the open field lines **80** provided that they experience scattering from ion-ion collisions. Although this collisional process does not lead to diffusion, it can change the direction of the ion velocity vector such that it points parallel to the magnetic field. These open field lines **80** connect the FRC topology of the core with the uniform applied field provided outside the FRC topology. Product ions emerge on different field lines, which they follow with a distribution of energies. Advantageously, the product ions and charge-neutralizing electrons emerge in the form of rotating annular beams from both ends of the fuel plasma. For example for a 50 MW design of a p-B<sup>11</sup> reaction, these beams will have a radius of about 50 centimeters and a thickness of about 10 centimeters. In the strong magnetic fields found outside the separatrix **84** (typically around 100 kG), the product ions have an associated distribution of gyro-radii that varies from a minimum value of about 1 cm to a maximum of around 3 cm for the most energetic product ions.

**[0141]** Initially the product ions have longitudinal as well as rotational energy characterized by  $\frac{1}{2}M(v_{par})^2$  and  $\frac{1}{2}$

$M(v_{perp})^2$ .  $v_{perp}$  is the azimuthal velocity associated with rotation around a field line as the orbital center. Since the field lines spread out after leaving the vicinity of the FRC topology, the rotational energy tends to decrease while the total energy remains constant. This is a consequence of the adiabatic invariance of the magnetic moment of the product ions. It is well known in the art that charged particles orbiting in a magnetic field have a magnetic moment associated with their motion. In the case of particles moving along a slow changing magnetic field, there also exists an adiabatic invariant of the motion described by  $\frac{1}{2} M(v_{perp})^2/B$ . The product ions orbiting around their respective field lines have a magnetic moment and such an adiabatic invariant associated with their motion. Since  $B$  decreases by a factor of about 10 (indicated by the spreading of the field lines), it follows that  $v_{perp}$  will likewise decrease by about 3.2. Thus, by the time the product ions arrive at the uniform field region their rotational energy would be less than 5% of their total energy; in other words almost all the energy is in the longitudinal component.

#### Energy Conversion

[0142] The direct energy conversion system of the present invention comprises an inverse cyclotron converter (ICC) 420 shown in FIGS. 19A and 20A coupled to a (partially illustrated) power core 436 of a colliding beam fusion reactor (CBFR) 410 to form a plasma-electric power generation system 400. A second ICC (not shown) may be disposed symmetrically to the left of the CBFR 410. A magnetic cusp 486 is located between the CBFR 410 and the ICC 420 and is formed when the CBFR 410 and ICC 420 magnetic fields merge.

[0143] Before describing the ICC 420 and its operation in detail, a review of a typical cyclotron accelerator is provided. In conventional cyclotron accelerators, energetic ions with velocities perpendicular to a magnetic field rotate in circles. The orbit radius of the energetic ions is determined by the magnetic field strength and their charge-to-mass ratio, and increases with energy. However, the rotation frequency of the ions is independent of their energy. This fact has been exploited in the design of cyclotron accelerators.

[0144] Referring to FIG. 21A, a conventional cyclotron accelerator 700 includes two mirror image C-shaped electrodes 710 forming mirror image D-shaped cavities placed in a homogenous magnetic field 720 having field lines perpendicular to the electrodes' plane of symmetry, i.e., the plane of the page. An oscillating electric potential is applied between the C-shaped electrodes (see FIG. 21B). Ions  $I$  are emitted from a source placed in the center of the cyclotron 700. The magnetic field 720 is adjusted so that the rotation frequency of the ions matches that of the electric potential and associated electric field. If an ion  $I$  crosses the gap 730 between the C-shaped electrodes 710 in the same direction as that of the electric field, it is accelerated. By accelerating the ion  $I$ , its energy and orbit radius increase. When the ion has traveled a half-circle arc (experiencing no increase in energy), it crosses the gap 730 again. Now the electric field between the C-shaped electrodes 710 has reversed direction. The ion  $I$  is again accelerated, and its energy is further increased. This process is repeated every time the ion crosses the gap 730 provided its rotation frequency continues to match that of the oscillating electric field (see FIG. 21C). If on the other hand a particle crosses the gap 730 when the electric field is in the opposite direction it will be decelerated and returned to the source at the center. Only particles with initial velocities

perpendicular to the magnetic field 720 and that cross the gaps 730 in the proper phase of the oscillating electric field will be accelerated. Thus, proper phase matching is essential for acceleration.

[0145] In principle, a cyclotron could be used to extract kinetic energy from a pencil beam of identical energetic ions. Deceleration of ions with a cyclotron, but without energy extraction has been observed for protons, as described by Bloch and Jeffries in *Phys. Rev.* 80, 305 (1950). The ions could be injected into the cavity such that they are brought into a decelerating phase relative to the oscillating field. All of the ions would then reverse the trajectory  $T$  of the accelerating ion shown in FIG. 21A. As the ions slow down due to interaction with the electric field, their kinetic energy is transformed into oscillating electric energy in the electric circuit of which the cyclotron is part. Direct conversion to electric energy would be achieved, tending to occur with very high efficiency.

[0146] In practice, the ions of an ion beam would enter the cyclotron with all possible phases. Unless the varying phases are compensated for in the design of the cyclotron, half of the ions would be accelerated and the other half decelerated. As a result, the maximum conversion efficiency would effectively be 50%. Moreover the annular fusion product ion beams discussed above are of an unsuitable geometry for the conventional cyclotron.

[0147] As discussed in greater detail below, the ICC of the present invention accommodates the annular character of the fusion product beams exiting the FRC of fusion reactor power core, and the random relative phase of the ions within the beam and the spread of their energies.

[0148] Referring back to FIG. 19A, a portion of a power core 436 of the CBFR 410 is illustrated on the left side, wherein a plasma fuel core 435 is confined in a FRC 470 formed in part due to a magnetic field applied by outside field coils 425. The FRC 470 includes closed field lines 482, a separatrix 484 and open field lines 480, which, as noted above, determines the properties of the annular beam 437 of the fusion products. The open field lines 480 extend away from the power core 436 towards the magnetic cusp 486. As noted above, fusion products emerge from the power core 436 along open field lines 480 in the form of an annular beam 437 comprising energetic ions and charge neutralizing electrons.

[0149] The geometry of the ICC 420 is like a hollow cylinder with a length of about five meters. Preferably, four or more equal, semi-cylindrical electrodes 494 with small, straight gaps 497 make up the cylinder surface. In operation, an oscillating potential is applied to the electrodes 494 in an alternating fashion. The electric field  $E$  within the converter has a quadrupole structure as indicated in the end view illustrated in FIG. 19B. The electric field  $E$  vanishes on the symmetry axis and increases linearly with the radius; the peak value is at the gap 497.

[0150] In addition, the ICC 420 includes outside field coils 488 to form a uniform field within the ICC's hollow cylinder geometry. Because the current runs through the ICC field coils 488 in a direction opposite to the direction of the current running through the CBFR field coils 425, the field lines 496 in the ICC 420 run in a direction opposite to the direction of the open field lines 480 of the CBFR 410. At an end furthest from the power core 436 of the CBFR 410, the ICC 420 includes an ion collector 492.

[0151] In between the CBFR 410 and the ICC 420 is a symmetric magnetic cusp 486 wherein the open field lines

**480** of the CBFR **410** merge with the field lines **496** of the ICC **420**. An annular shaped electron collector **490** is positioned about the magnetic cusp **486** and electrically coupled to the ion collector **498**. As discussed below, the magnetic field of the magnetic cusps **486** converts the axial velocity of the beam **437** to a rotational velocity with high efficiency. FIG. **19C** illustrates a typical ion orbit **422** within the converter **420**.

[0152] The CBFR **410** has a cylindrical symmetry. At its center is the fusion power core **436** with a fusion plasma core **435** contained in a FRC **470** magnetic field topology in which the fusion reactions take place. As noted, the product nuclei and charge-neutralizing electrons emerge as annular beams **437** from both ends of the fuel plasma **435**. For example for a 50 MW design of a p-B<sup>11</sup> reaction, these beams will have a radius of about 50 cm and a thickness of about 10 cm. The annular beam has a density  $n \approx 10^7$ - $10^8$  cm<sup>-3</sup>. For such a density, the magnetic cusp **486** separates the electrons and ions. The electrons follow the magnetic field lines to the electron collector **490** and the ions pass through the cusp **486** where the ion trajectories are modified to follow a substantially helical path along the length of the ICC **420**. Energy is removed from the ions as they spiral past the electrodes **494** connected to a resonant circuit (not shown). The loss of perpendicular energy is greatest for the highest energy ions that initially circulate close to the electrodes **494**, where the electric field is strongest.

[0153] The ions arrive at the magnetic cusp **486** with the rotational energy approximately equal to the initial total energy, i.e.,  $\frac{1}{2} M v_p^2 \approx \frac{1}{2} M v_0^2$ . There is a distribution of ion energies and ion initial radii  $r_0$  when the ions reach the magnetic cusp **486**. However, the initial radii  $r_0$  tends to be approximately proportional to the initial velocity  $v_0$ . The radial magnetic field and the radial beam velocity produce a Lorentz force in the azimuthal direction. The magnetic field at the cusp **486** does not change the particle energy but converts the initial axial velocity  $v_p \approx v_0$  to a residual axial velocity  $v_z$  and an azimuthal velocity  $v_\perp$ , where  $v_0^2 = v_z^2 + v_\perp^2$ . The value of the azimuthal velocity  $v_\perp$  can be determined from the conservation of canonical momentum

$$P_\theta = M r_0 v_\perp - \frac{q B_0 r_0^2}{2c} = \frac{q B_0 r_0^2}{2c} \quad (5)$$

[0154] A beam ion enters the left hand side of the cusp **486** with  $B_z = B_0$ ,  $v_z = v_0$ ,  $v_\perp = 0$  and  $r = r_0$ . It emerges on the right hand side of the cusp **486** with  $r = r_0$ ,  $B_z = -B_0$ ,  $v_\perp = q B_0 r_0 / M c$  and  $v_z = \sqrt{v_0^2 - v_\perp^2}$

$$\frac{v_z}{v_0} = \sqrt{1 - \left(\frac{r_0 \Omega_0}{v_0}\right)^2} \quad (6)$$

where

$$\Omega_0 = \frac{q B_0}{M c}$$

is the cyclotron frequency. The rotation frequency of the ions is in a range of about 1-10 MHz, and preferably in a range of about 5-10 MHz, which is the frequency at which power generation takes place.

[0155] In order for the ions to pass through the cusp **486**, the effective ion gyro-radius must be greater than the width of the cusp **486** at the radius  $r_0$ . It is quite feasible experimentally to reduce the axial velocity by a factor of 10 so that the residual axial energy will be reduced by a factor of 100. Then 99% of the ion energy will be converted to rotational energy. The ion beam has a distribution of values for  $v_0$  and  $r_0$ . However, because  $r_0$  is proportional to  $v_0$  as previously indicated by the properties of the FRC based reactor, the conversion efficiency to rotational energy tends to be 99% for all ions.

[0156] As depicted in FIG. **19B**, the symmetrical electrode structure of the ICC **420** of the present invention preferably includes four electrodes **494**. A tank circuit (not shown) is connected to the electrode structures **494** so that the instantaneous voltages and electric fields are as illustrated. The voltage and the tank circuit oscillate at a frequency of  $\omega = \Omega_0$ . The azimuthal electric field  $E$  at the gaps **497** is illustrated in FIG. **19B** and FIG. **22**. FIG. **22** illustrates the electric field in the gaps **497** between electrodes **494** and the field an ion experiences as it rotates with angular velocity  $\Omega_0$ . It is apparent that in a complete revolution the particle will experience alternately acceleration and deceleration in an order determined by the initial phase. In addition to the azimuthal electric field  $E_\theta$  there is also a radial electric field  $E_r$ . The azimuthal field  $E_\theta$  is maximum in the gaps **497** and decreases as the radius decreases. FIG. **22** assumes the particle rotates maintaining a constant radius. Because of the gradient in the electric field the deceleration will always dominate over the acceleration. The acceleration phase makes the ion radius increase so that when the ion next encounters a decelerating electric field the ion radius will be larger. The deceleration phase will dominate independent of the initial phase of the ion because the radial gradient of the azimuthal electric field  $E_\theta$  is always positive. As a result, the energy conversion efficiency is not limited to 50% due to the initial phase problem associated with conventional cyclotrons. The electric field  $E_r$  is also important. It also oscillates and produces a net effect in the radial direction that returns the beam trajectory to the original radius with zero velocity in the plane perpendicular to the axis as in FIG. **19C**.

[0157] The process by which ions are always decelerated is similar to the principle of strong focusing that is an essential feature of modern accelerators as described in U.S. Pat. No. 2,736,799. The combination of a positive (focusing) and negative lens (defocusing) is positive if the magnetic field has a positive gradient. A strong focusing quadrupole doublet lens is illustrated in FIG. **23**. The first lens is focusing in the x-direction and defocusing in the y-direction. The second lens is similar with x and y properties interchanged. The magnetic field vanishes on the axis of symmetry and has a positive radial gradient. The net results for an ion beam passing through both lenses is focusing in all directions independent of the order of passage.

[0158] Similar results have been reported for a beam passing through a resonant cavity containing a strong axial magnetic field and operating in the TE<sub>111</sub> mode (see Yoshikawa et al.). This device is called a peniotron. In the TE<sub>111</sub> mode the resonant cavity has standing waves in which the electric field has quadrupole symmetry. The results are qualitatively similar to some of the results described herein. There are quanti-

tative differences in that the resonance cavity is much larger in size (10 meter length), and operates at a much higher frequency (155 MHz) and magnetic field (10 T). Energy extraction from the high frequency waves requires a rectenna. The energy spectrum of the beam reduces the efficiency of conversion. The existence of two kinds of ions is a more serious problem, but the efficiency of conversion is adequate for a D-He<sup>3</sup> reactor that produces 15 MeV protons.

[0159] A single particle orbit **422** for a particle within the ICC **420** is illustrated in FIG. **19C**. This result was obtained by computer simulation and a similar result was obtained for the peniotron. An ion entering at some radius  $r_0$  spirals down the length of the ICC and after losing the initial rotational energy converges to a point on a circle of the same radius  $r_0$ . The initial conditions are asymmetric; the final state reflects this asymmetry, but it is independent of the initial phase so that all particles are decelerated. The beam at the ion collector end of the ICC is again annular and of similar dimensions. The axial velocity would be reduced by a factor of 10 and the density correspondingly increased. For a single particle an extracting efficiency of 99% is feasible. However, various factors, such as perpendicular rotational energy of the annular beam before it enters the converter, may reduce this efficiency by about 5%. Electric power extraction would be at about 1-10 MHz and preferably about 5-10 MHz, with additional reduction in conversion efficiency due to power conditioning to connect to a power grid.

[0160] As shown in FIGS. **20A** and **20B**, alternative embodiments of the electrode structures **494** in the ICC **420** may include two symmetrical semi-circular electrodes and/or tapered electrodes **494** that taper towards the ion collector **492**.

[0161] Adjustments to the ion dynamics inside the main magnetic field of the ICC **420** may be implemented using two auxiliary coil sets **500** and **510**, as shown in FIGS. **24A** and **24B**. Both coil sets **500** and **510** involve adjacent conductors with oppositely directed currents, so the magnetic fields have a short range. A magnetic-field gradient, as schematically illustrated in FIG. **24A**, will change the ion rotation frequency and phase. A multi-pole magnetic field, as schematically illustrated in FIG. **24B**, will produce bunching, as in a linear accelerator.

#### Reactor

[0162] FIG. **25** illustrates a 100 MW reactor. The generator cut away illustrates a fusion power core region having superconducting coils to apply a uniform magnetic field and a flux coil for formation of a magnetic field with field-reversed topology. Adjacent opposing ends of the fusion power core region are ICC energy converters for direct conversion of the kinetic energy of the fusion products to electric power. The support equipment for such a reactor is illustrated in FIG. **26**.

#### Propulsion System

[0163] FIG. **27** illustrates a plasma-thrust propulsion system **800**. The system includes a FRC power core **836** in which a fusion fuel core **835** is contained and from both ends of which fusion products emerge in the form of an annular beam **837**. An ICC energy converter **820** coupled to one end of the power core. A magnetic nozzle **850** is positioned adjacent the other end of the power core. The annular beam **837** of fusion products stream from one end of the fusion power core along

field lines into the ICC for energy conversion and from the other end of the power core along field lines out of the nozzle for thrust T.

[0164] While the invention is susceptible to various modifications and alternative forms, a specific example thereof has been shown in the drawings and is herein described in detail. It should be understood, however, that the invention is not to be limited to the particular form disclosed, but to the contrary, the invention is to cover all modifications, equivalents, and alternatives falling within the spirit and scope of the appended claims.

What is claimed is:

1. A plasma-electric power generation system comprising a fusion reactor comprising
  - a cylindrical chamber having first and second ends and a longitudinally extending axis,
  - a first magnetic field generator, wherein the first magnetic field generator comprises a plurality of annular coils with a first polarity and positioned about the chamber along the axis, and
  - a means for generating an azimuthal electric field within the chamber to accelerate an annular plasma layer within the chamber,
 an inverse cyclotron energy converter coupled to a first end of the chamber, the converter having a longitudinal extending axis coextensive with the longitudinal axis of the chamber, the converter comprising
  - four or more arcuate and longitudinally extending electrodes forming a cylindrical surface and in spaced relation to form a longitudinally extending gaps between adjacent electrodes,
  - a second magnetic field generator, wherein the second magnetic field generator comprises a plurality of annular coils with a second polarity and positioned about the electrodes along the axis, wherein the first and second polarity of the plurality of coils of the first and second magnetic field generators being adapted to cause the formation of a magnetic cusp positioned between the first and second magnetic field generators,
  - an annular electron collector positioned interposing the first and second magnetic field generators and about a first end of the four or more electrodes and the chamber at a formation region for the magnetic cusp, and
  - an ion collector positioned adjacent a second end of the four or more electrodes normal to the longitudinal axis of the converter.
2. The system of claim 1 further comprising a second inverse cyclotron energy converter coupled to the second end of the chamber.
3. The system of claim 1 wherein the reactor and converter form a cylindrical vessel.
4. The system of claim 1 further comprising a resonant circuit coupled to the four or more electrodes.
5. The system of claim 1 further comprising a tank circuit coupled to the four or more electrodes.
6. The system of claim 3, wherein the field lines of the magnetic field generatable by the field coils of the first magnetic field generator run in a direction opposite to the field lines of the magnetic field generatable by the field coils of the second magnetic field generator.
7. The system of claim 1 wherein the electron collector and ion collector are electrically coupled.
8. The system of claim 1 wherein the four or more electrodes are symmetrical.

**9.** The system of claim **1** wherein the first magnetic field generator further comprises first and second sets of mirror coils disposed in spaced relation about the vessel and defining a power core region therebetween.

**10.** The system of claim **9** wherein the means for generating an azimuthal electric field comprises a current coil concentric with a principle axis of the vessel and positioned within the power core region.

**11.** The system of claim **10** wherein the fusion reactor further comprises plasma injectors coupled to the vessel.

**12.** The system of claim **11** wherein the plasma injectors are axially oriented to inject plasma toward a mid-plane of the power core region.

**13.** The system of claim **1** wherein the first magnetic field generator is tunable.

**14.** The system of claim **13** further comprising a control system coupled to the first magnetic field generator.

**15.** The system of claim **10** wherein the current coil is a betatron flux coil.

**16.** The system of claim **11** wherein the current coil includes parallel windings of a plurality of separate coils.

**17.** The system of claim **3** wherein the fusion reactor further comprises ion beam injectors coupled to the vessel.

**18.** The system of claim **18** wherein the ion beam injectors include a means for neutralizing the electric charge of the ion beams emitted from the injectors.

\* \* \* \* \*