



US 20090266083A1

(19) **United States**

(12) **Patent Application Publication**
Shin et al.

(10) **Pub. No.: US 2009/0266083 A1**

(43) **Pub. Date: Oct. 29, 2009**

(54) **ROTATION TYPE REGENERATOR AND
MAGNETIC REFRIGERATOR USING THE
REGENERATOR**

(86) PCT No.: PCT/KR06/04729

§ 371 (c)(1),
(2), (4) Date: Feb. 17, 2009

(75) Inventors: **Seung Hoon Shin**, Seoul (KR);
Dong Kwan Lee, Seoul (KR)

(30) **Foreign Application Priority Data**

Jul. 10, 2006 (KR) 10-2006-0064344

Correspondence Address:
**HAMRE, SCHUMANN, MUELLER & LARSON,
P.C.
P.O. BOX 2902
MINNEAPOLIS, MN 55402-0902 (US)**

Publication Classification

(51) **Int. Cl.**
F25B 21/00 (2006.01)

(52) **U.S. Cl.** **62/3.1**

(73) Assignee: **DAEWOO ELECTRONICS
CORPORATION**, Seoul (KR)

(57) **ABSTRACT**

(21) Appl. No.: **12/307,876**

The present invention relates to a regenerator using a rotation type magnet member and an active magnetic regenerator, and a magnetic refrigerator using the same.

(22) PCT Filed: **Nov. 13, 2006**

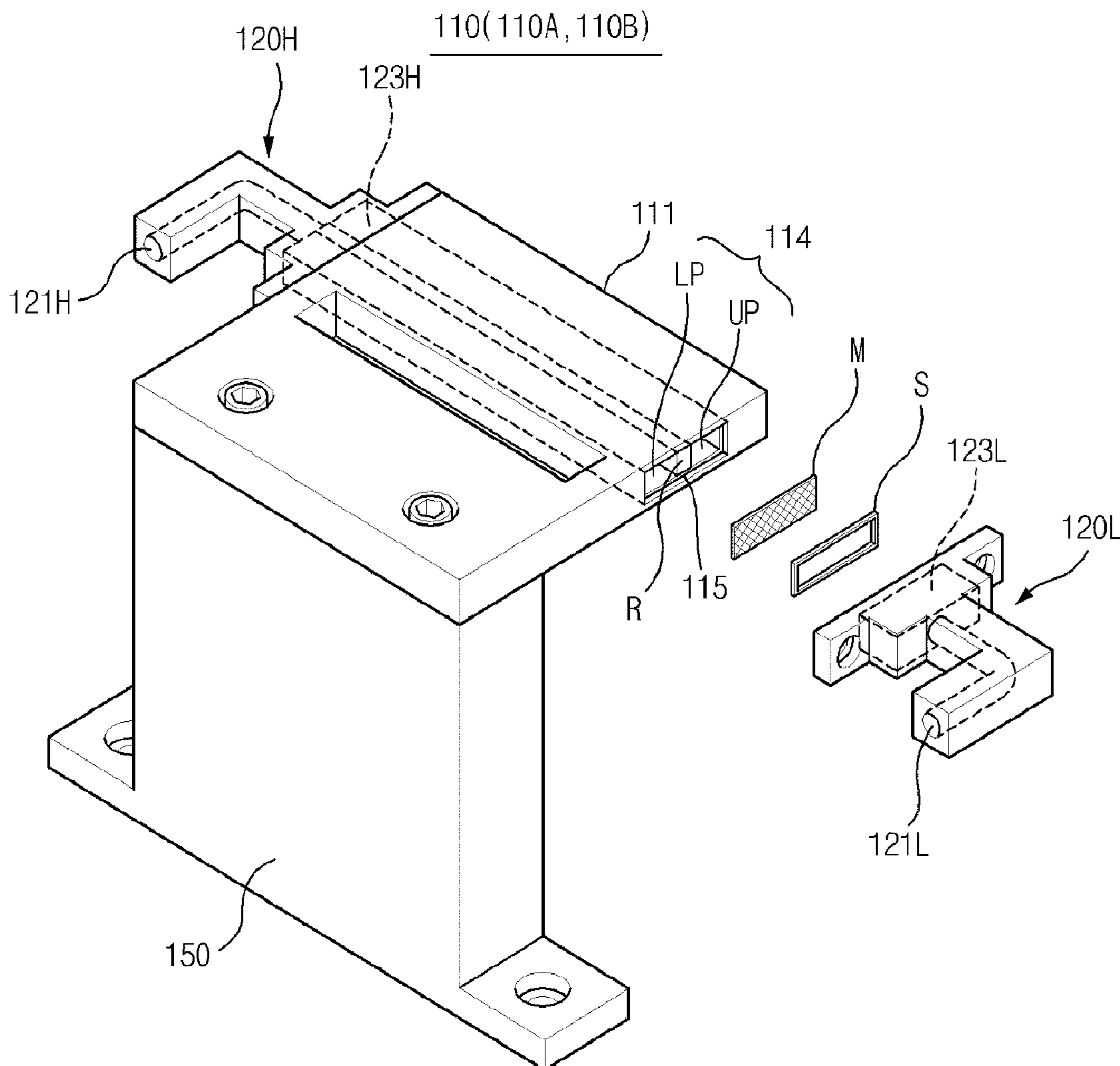

[Fig. 1]

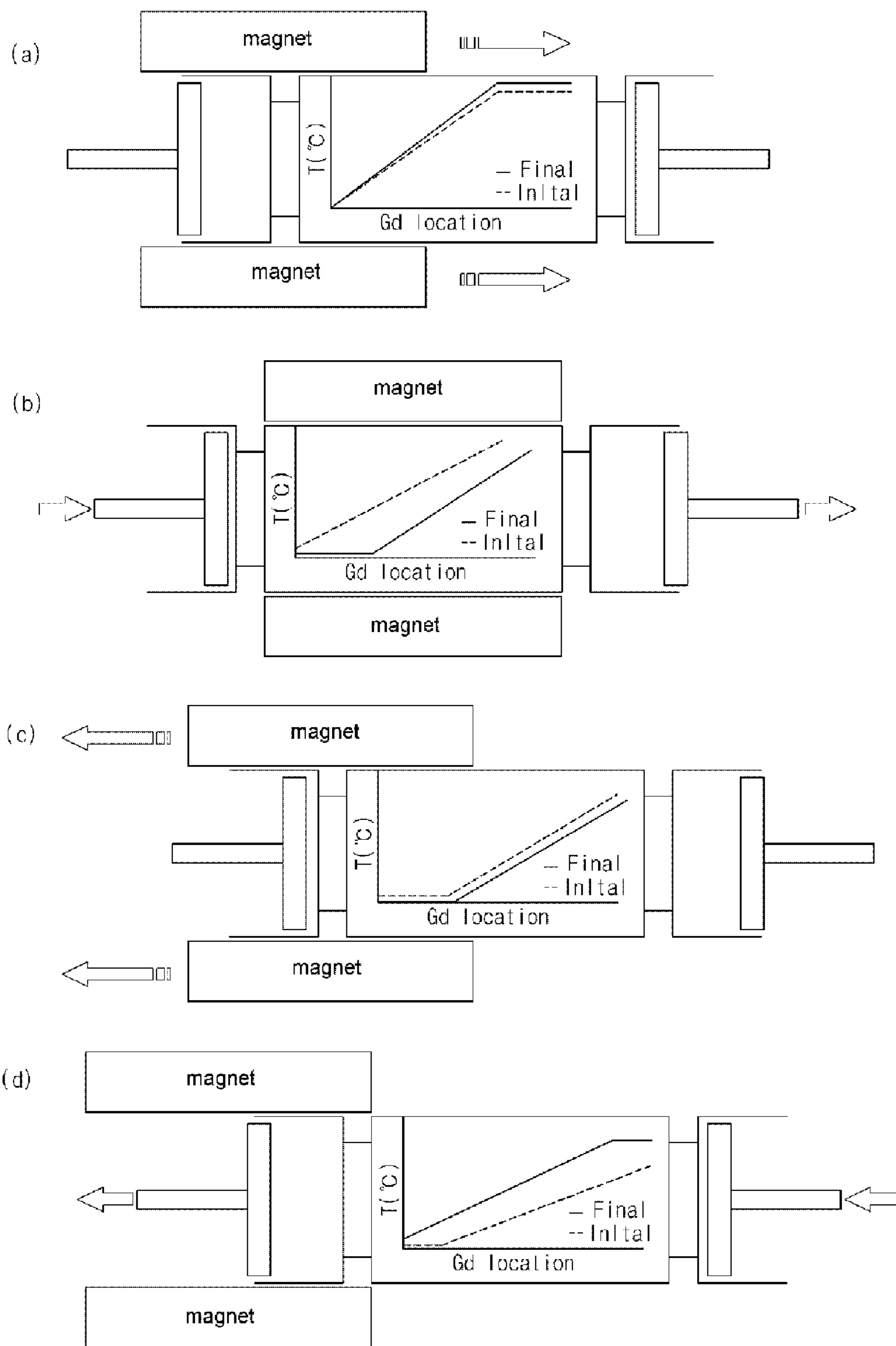

[Fig. 2]

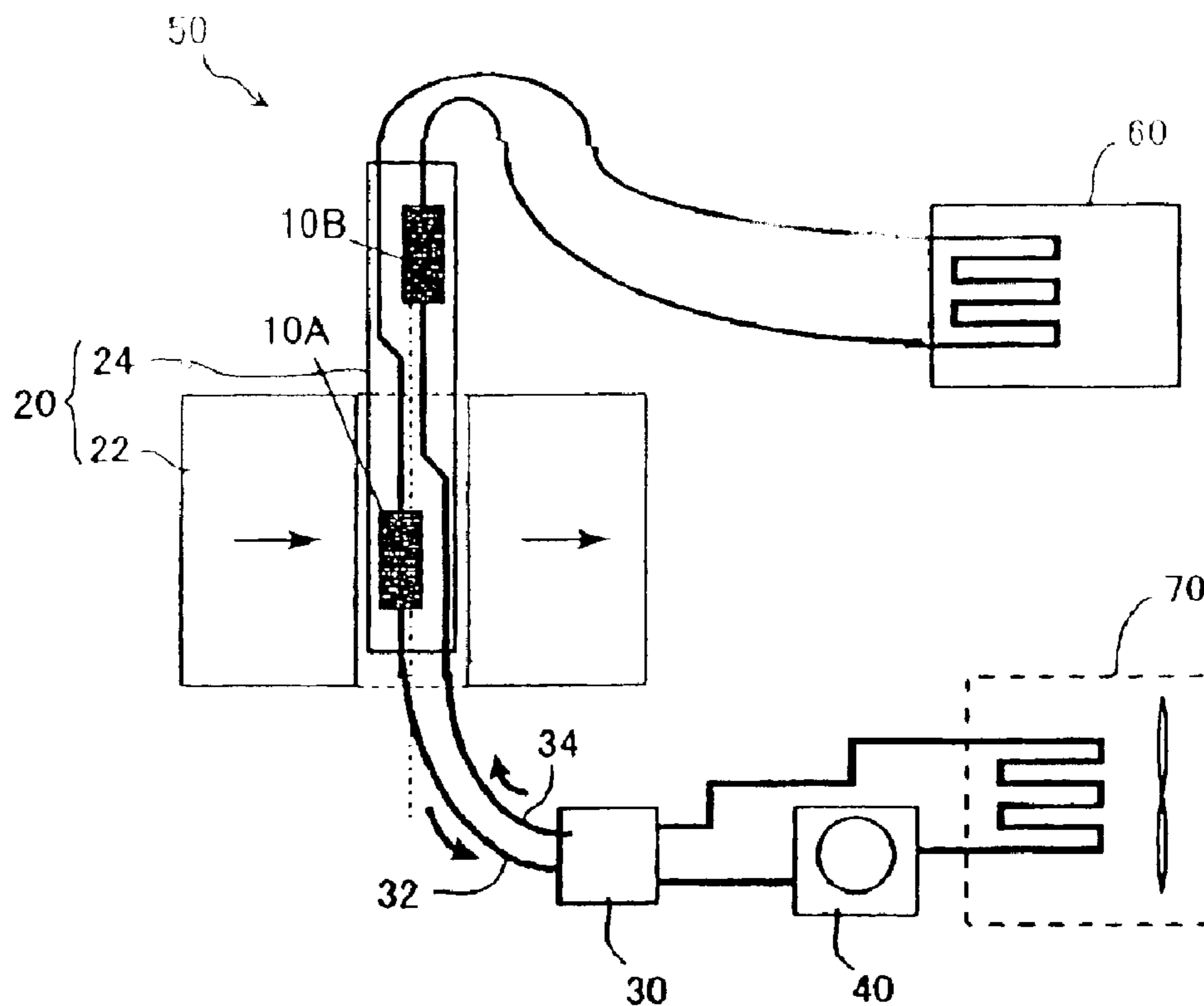

[Fig. 3]

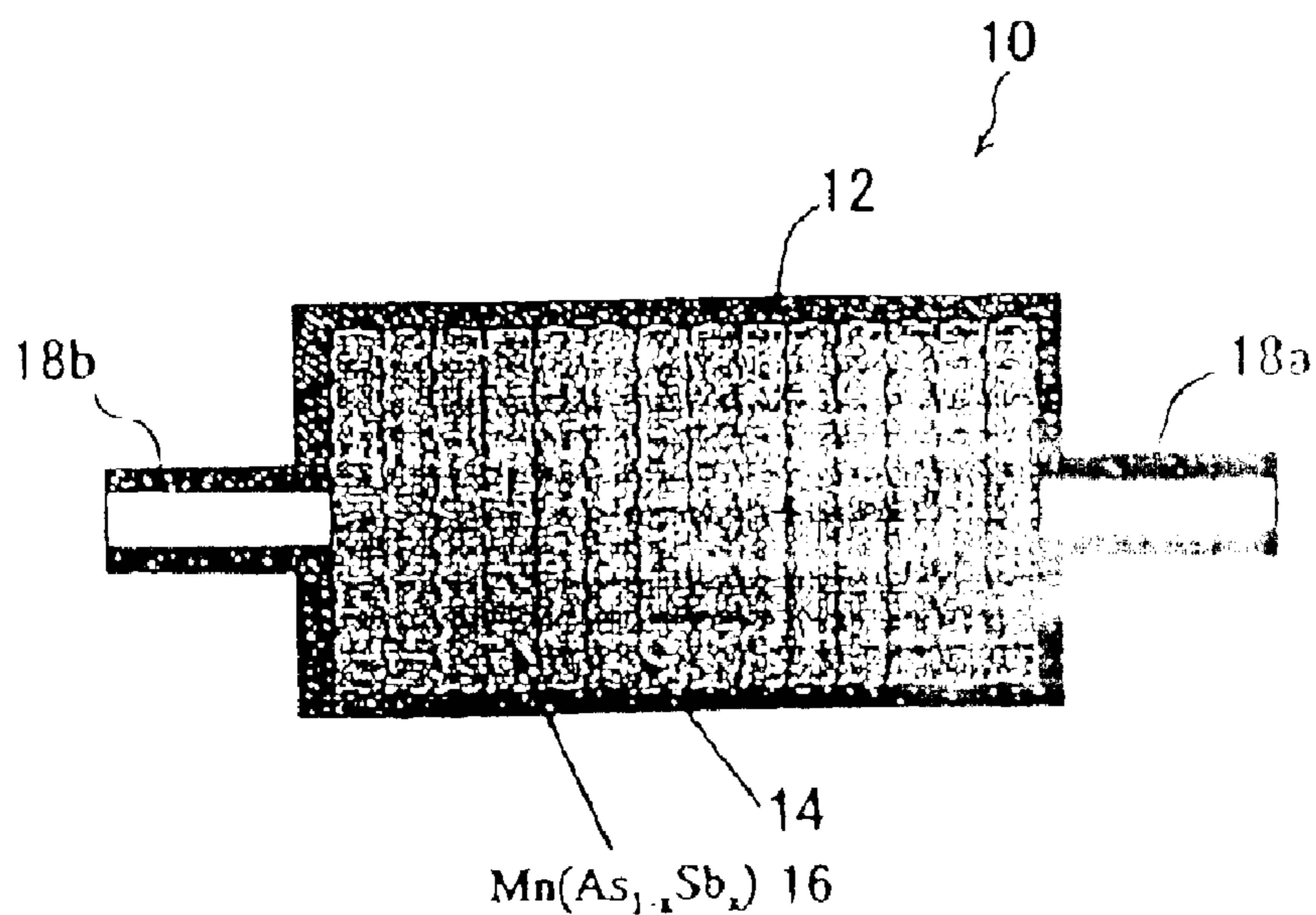

[Fig. 4]

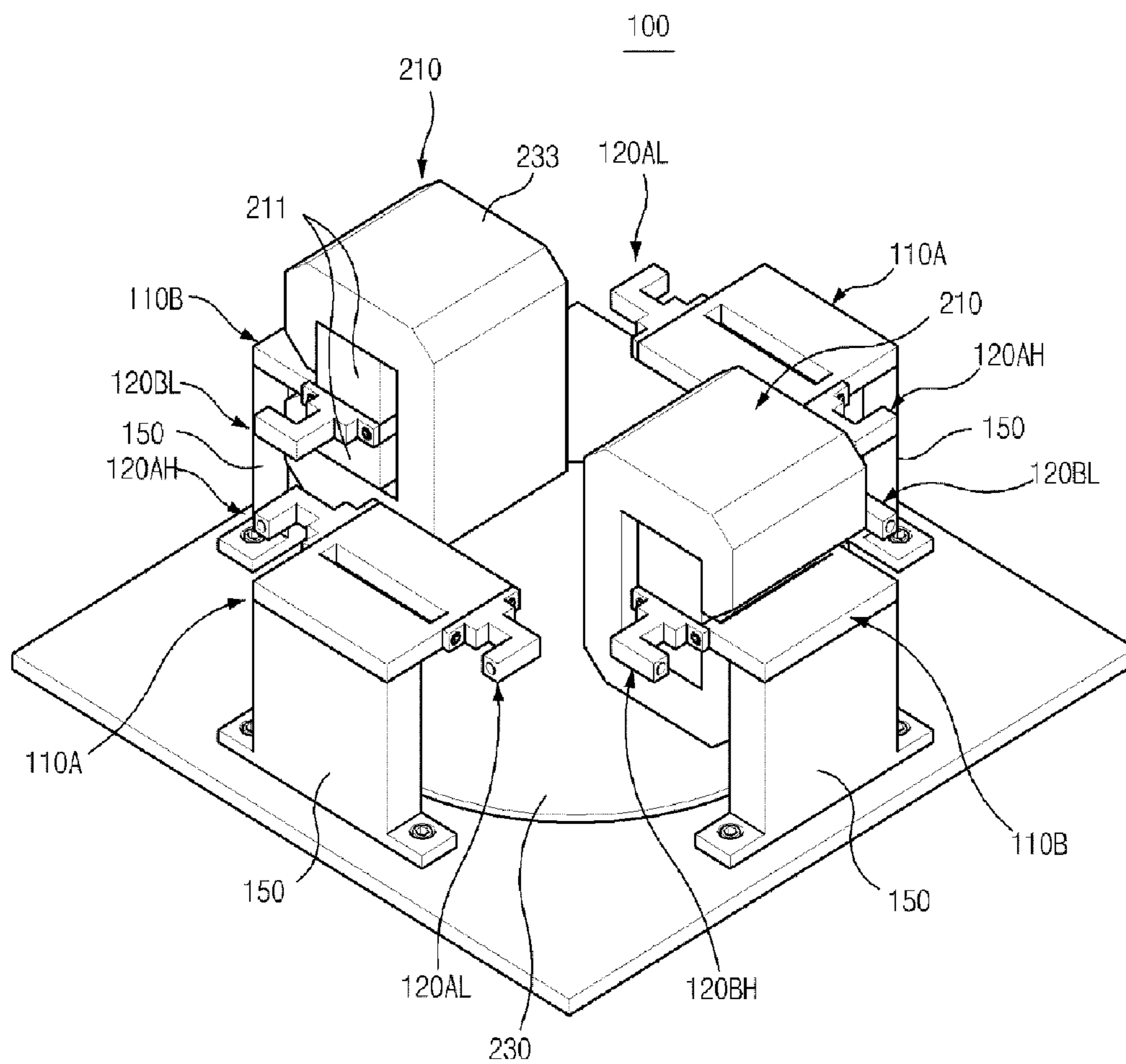

[Fig. 5]

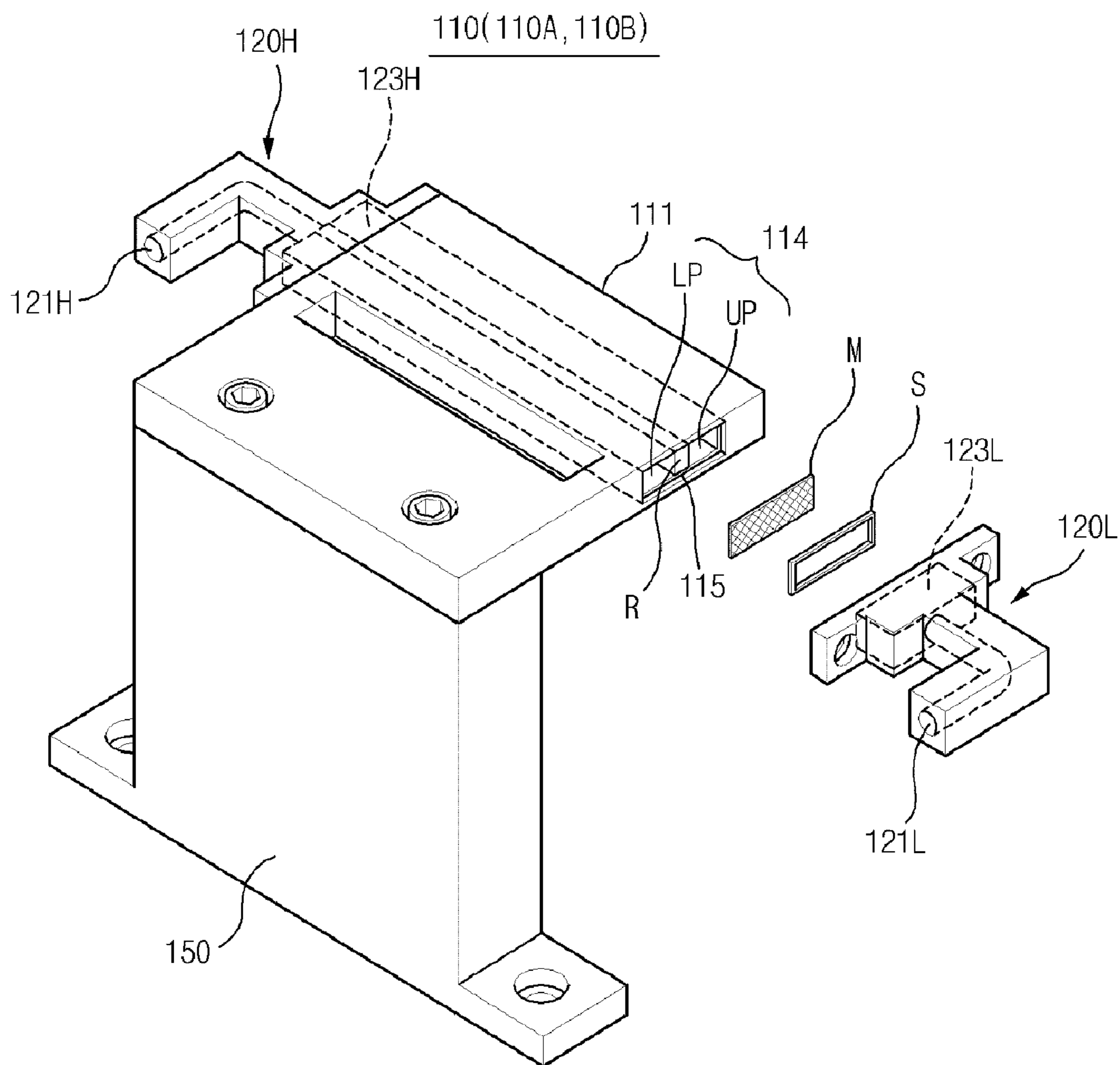

[Fig. 6]

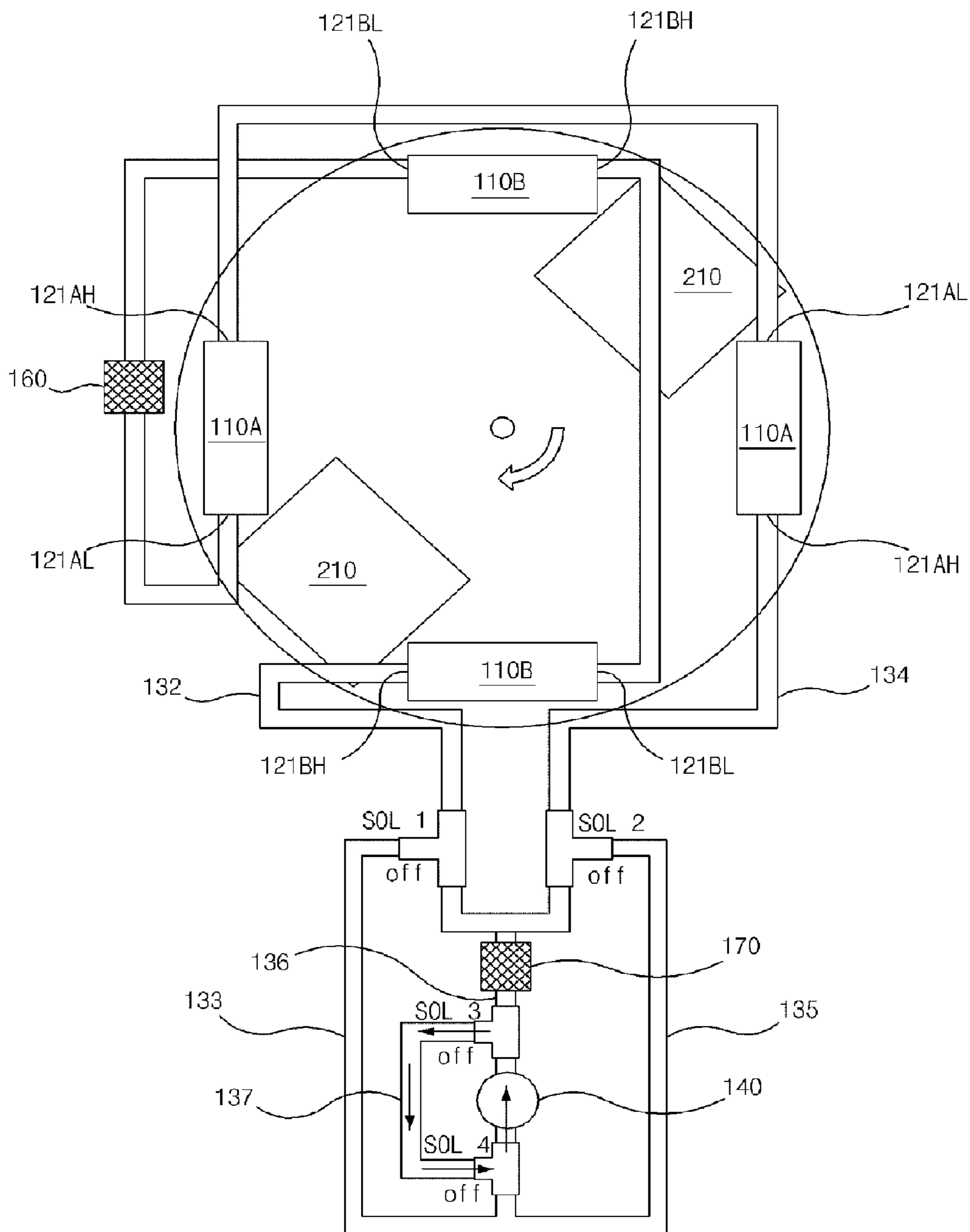

[Fig. 7]

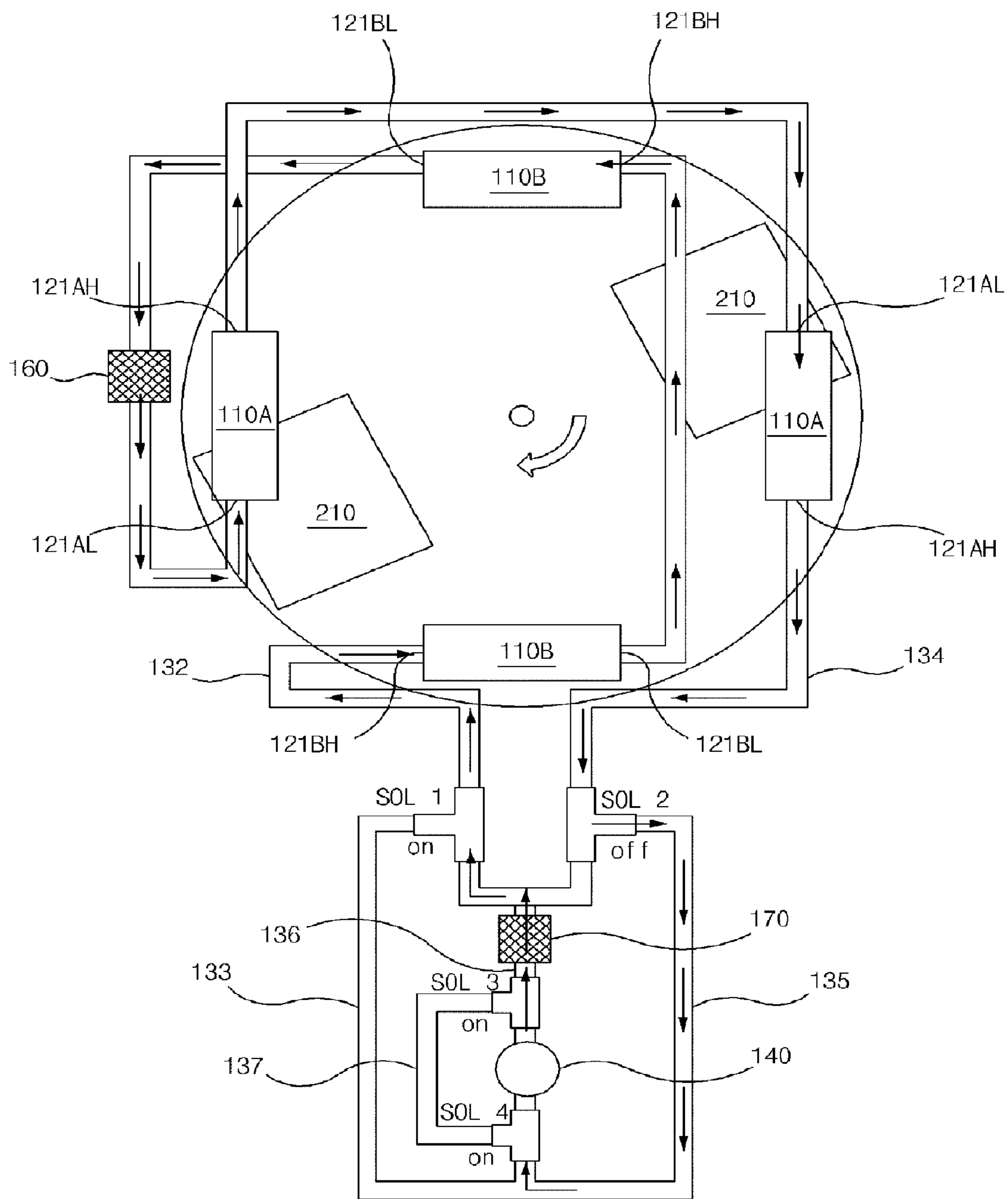

[Fig. 8]

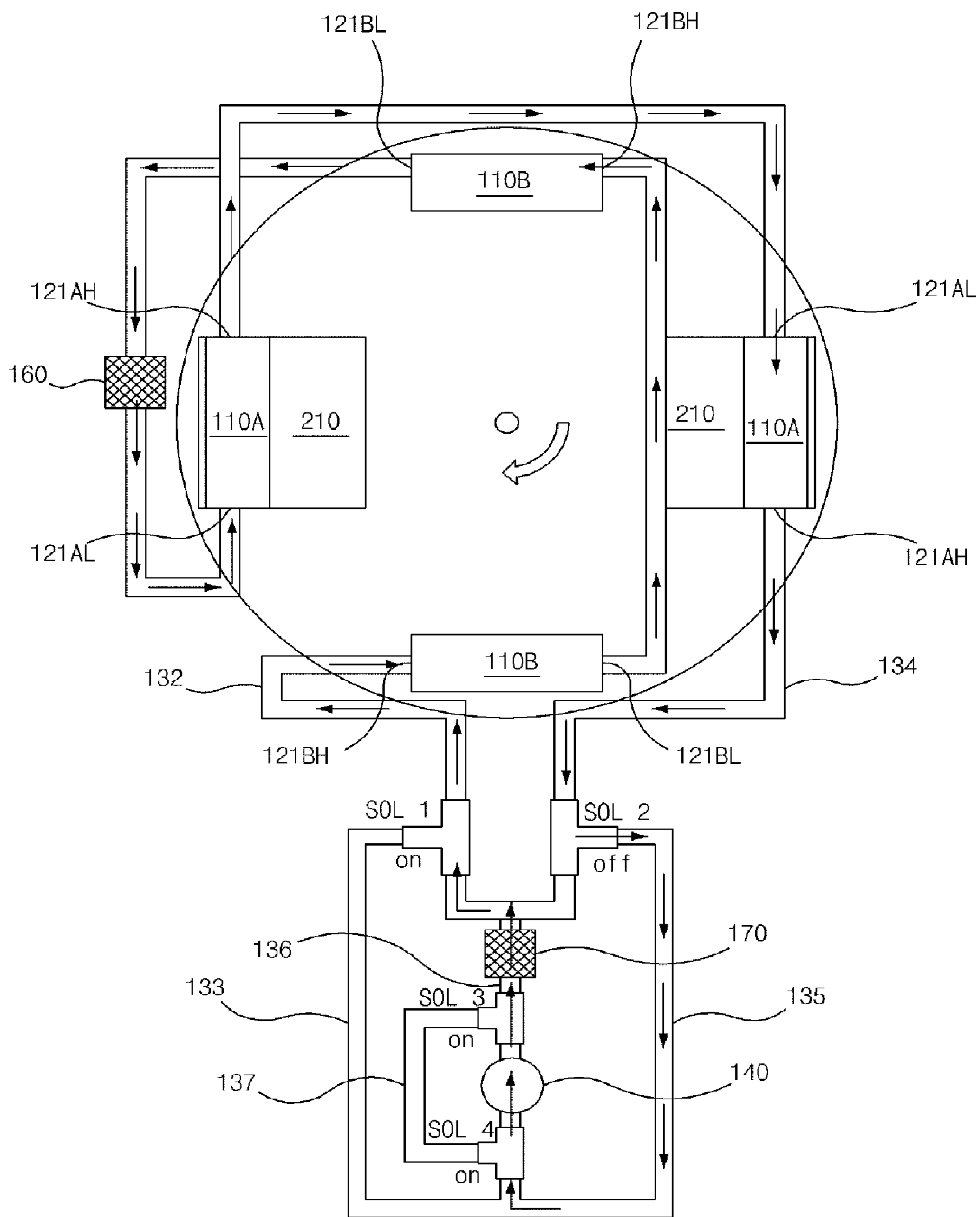

[Fig. 9]

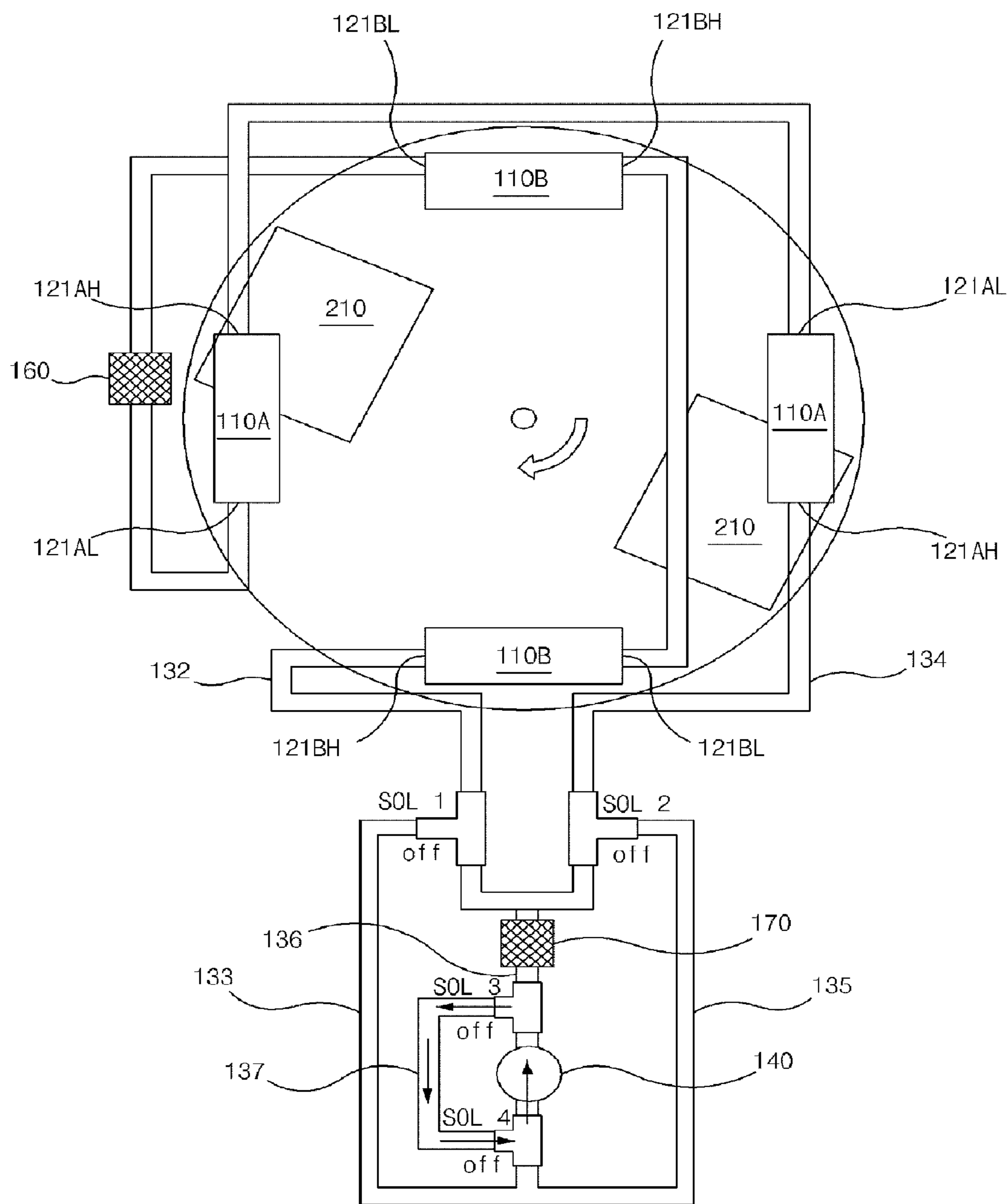

[Fig. 10]

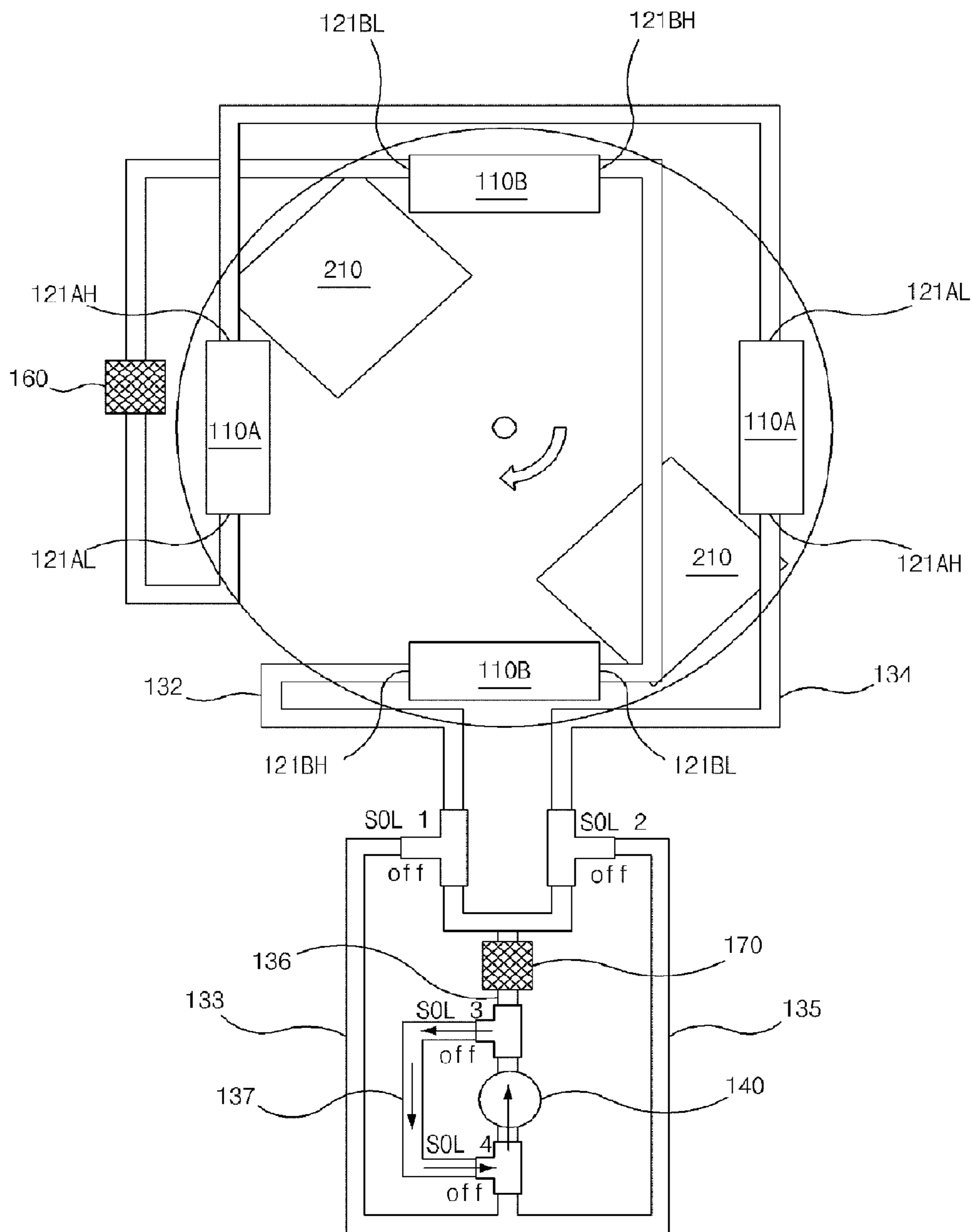

[Fig. 11]

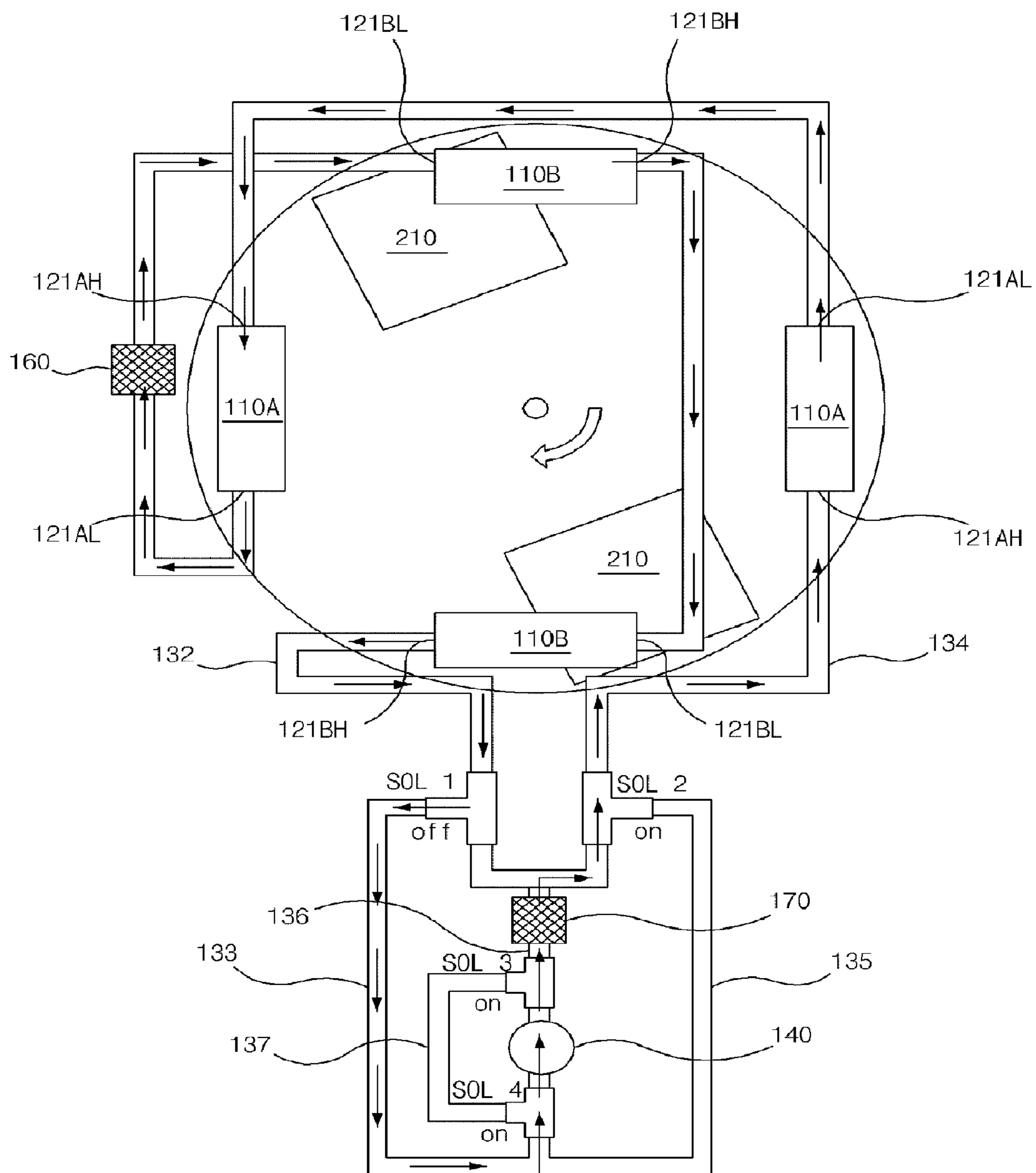

[Fig. 12]

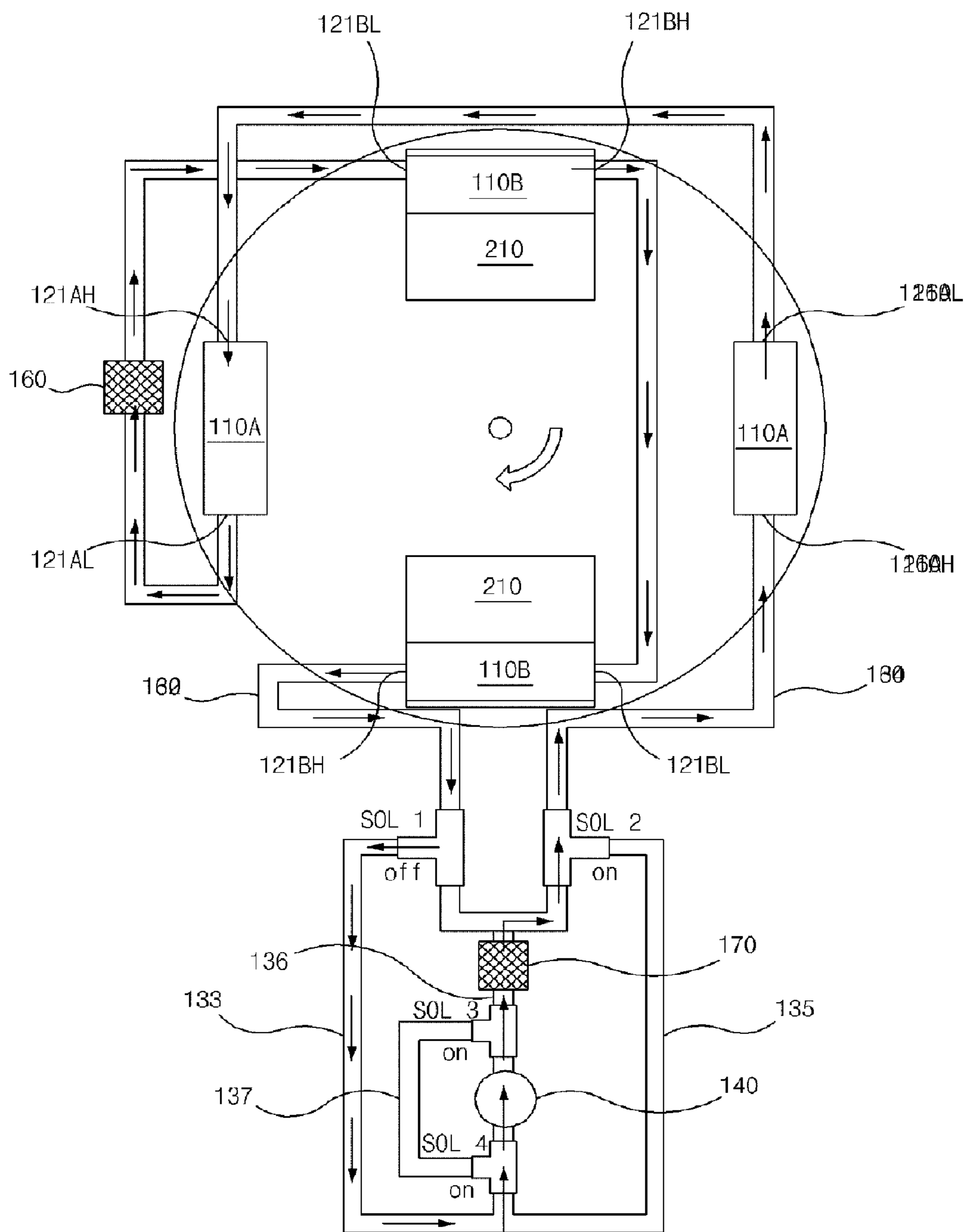

[Fig. 14]

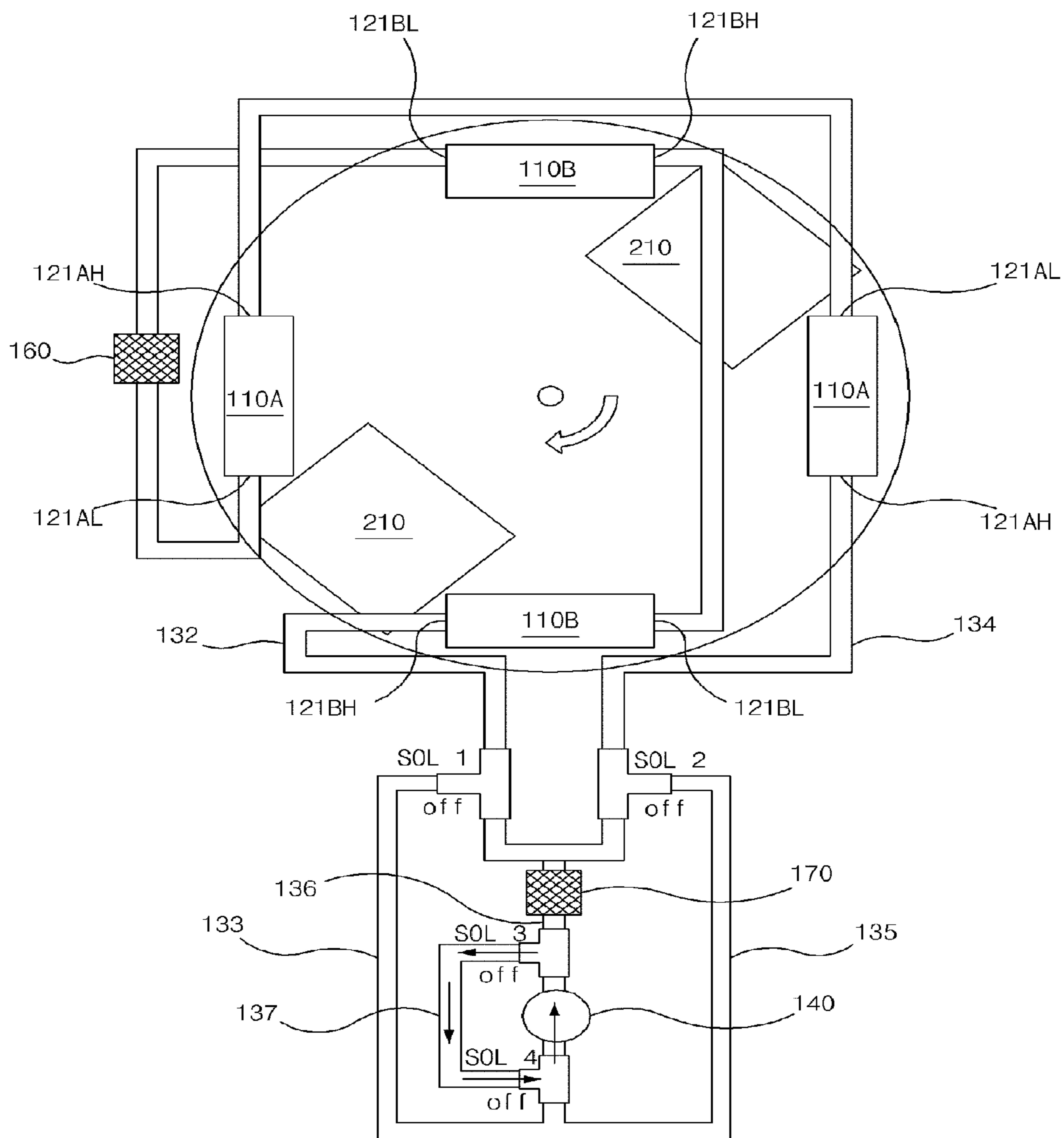

**ROTATION TYPE REGENERATOR AND
MAGNETIC REFRIGERATOR USING THE
REGENERATOR**

TECHNICAL FIELD

[0001] The present invention relates to a regenerator using a rotation type magnet member and an active magnetic regenerator (hereinafter referred to as "AMR"), and a magnetic refrigerator using the same.

BACKGROUND ART

[0002] A conventional active magnetic regenerator is disclosed in U.S. Pat. No. 6,826,915. As shown in FIG. 1, (a) a temperature of a magnetic refrigerant material which has a magnetic field applied thereto as a magnet moves to a right increases from a dotted line to a solid line. (b) The temperature of the magnetic refrigerant material drops from the dotted line to the solid line as a heat transfer fluid at a cold side moves to a hot side, and the heat transfer fluid is gradually heated to be hot at a right outlet, thereby emitting heat by an heat exchange with the hot side. (c) The temperature of the magnetic refrigerant material which has a magnetic field erased as the magnet moves to a left decreases more from the dotted line to the solid line, (d) Due to the movement of the heat transfer fluid from the hot side to the cold side, the magnetic refrigerant material is heated from the temperature of the dotted line to that of the solid line, and the heat transfer fluid is relatively cooled to be cold at a left outlet, thereby absorbing heat from the cold side to cool the cold side.

[0003] As shown in FIGS. 2 and 3, in accordance with the conventional active magnetic regenerator including the above-described cycle, a temperature of the heat transfer fluid heated in a first AMR bed 10A in the magnetic field is dropped to an atmospheric temperature by a hot-side heat exchanger 70 and the heat transfer fluid is then passed through the second AMR bed 10B. At the same time, since the second AMR bed 10B is outside the magnetic field, a magnetic refrigerant material layer 16 has a low temperature, the temperature of the heat transfer fluid drops while passing through the magnetic refrigerant material layer 16. The heat transfer fluid having the low temperature passes through a cold-side heat exchanger 60 and then enters the first AMR bed 10A to be heated. The heat transfer fluid then flows to the hot-side heat exchanger 70, the second AMR bed 10B and the cold-side heat exchanger 60 to complete the one cycle. Contrarily, when the second AMR bed 10B is moved to a magnet circuit 22 by a movable mechanism 24, a channel switch 30 reverses the flow of the heat transfer fluid to generate a reverse cycle.

[0004] (On the other hand, as shown in FIG. 3, an AMR bed 10 includes a container 12 of a cylinder type, a plurality of magnetic refrigerant material layers 16 stored inside the container 12, and meshes 14. The container 12 includes heat transfer fluid inlet/outlet ports 18a and 18b, which may be connected to the heat exchange the 32 or 34.

DISCLOSURE OF INVENTION

Technical Problem

[0005] However, the inlet/outlet ports 18a and 18b are installed at a center portion of the container 12. Therefore, the heat transfer fluid does not flow through an entire cross-section of the container 12, which renders the heat transfer

fluid to flow through the magnetic refrigerant material 16 at the same spot, thereby making a smooth heat exchange difficult.

Technical Solution

[0006] It is an object of the present invention to provide a regenerator and a magnetic refrigerator using the same wherein a heat transfer fluid is dispersed and flow through an entire the magnetic refrigerant material to obtain a superior heat exchange characteristic.

[0007] In order to achieve the above-described object, there is provided a rotational regenerator, comprising: a first AMR and a second AMR including a magnetocaloric material for passing through a flow of a heat transfer fluid, a magnet; and a magnet rotating assembly for applying or erasing a magnetic field by disposing the magnet at the first AMR or the second AMR, wherein each of the first AMR and the second AMR comprises an AMR bed disposed in a lengthwise direction of a through-hole being filled up with the magnetocaloric material, and cold-side and hot-side AMR nozzles coupled to the AMR bed and connected to the through-hole, and wherein one of the AMR nozzles includes a distribution chamber for uniformly distributing the heat transfer fluid to an entirety of a cross-section of the through-hole.

[0008] There is also provided a magnetic refrigerator, comprising: a first AMR, and a second AMR including a magnetocaloric material for passing through a flow of a heat transfer fluid; a magnet; a magnetic rotating assembly for applying or erasing a magnetic field by disposing the magnet at the first AMR or the second AMR; and cold-side and hot-side heat exchangers thermally connected to the first AMR and the second AMR, wherein each of the first AMR and the second AMR comprises an AMR bed disposed in a lengthwise direction of a through-hole being filled up with the magnetocaloric material, and cold-side and hot-side AMR nozzles coupled to the AMR bed and connected to the through-hole, and wherein one of the AMR nozzles includes a distribution chamber for uniformly distributing the heat transfer fluid to an entirety of a cross-section of the through-hole.

[0009] It is preferable that the magnet rotating assembly comprises a body for supporting the magnet disposed upper and lower sides of the first AMR or the second AMR, a rotating plate for supporting the body, and a rotational power transfer member for transferring a rotational power to the rotating plate, and wherein each of the first AMR and the second AMR is supported in a horizontal direction perpendicular to a vertical tower.

[0010] It preferable that the distribution chamber is connected to a first end of the AMR nozzle, and an inlet/outlet is formed at a second end thereof, and wherein the inlet/outlet of the AMR nozzle is right-angled such that the inlet/outlet is on a same plane with the first AMR and the second AMR, thereby reducing a radius of a rotation by preventing an interference with the rotation of the magnet.

[0011] In addition, when the AMRs include plastic, a wide temperature slope is obtained by an adiabatic state.

[0012] Moreover, when a mesh and a packing are disposed between the AMR bed and the AMR nozzle, a leakage of the magnetocaloric material and the heat transfer fluid is prevented.

[0013] In addition, when the through-hole comprises an upper through-hole and a lower through-hole divided by a

ribbed compartment, a distortion of the AMR bed due to a pressure of the heat transfer fluid is prevented.

Advantageous Effects

[0014] As described above, the regenerator and the magnetic refrigerator using the same in accordance with the present invention have following advantages,

[0015] As a first advantage, since the magnetic refrigerator includes the distribution chamber having a size almost identical to that of the cross-section of the magnetocaloric material of the AMR bed, the heat transfer fluid flows uniformly throughout the magnetocaloric material, resulting in a suppression of the corrugation formed by partial flow thereof to improve the heat exchange efficiency.

[0016] As a second advantage, the heat exchange efficiency is improved by employing the rotational AMR cycle operation.

[0017] As a third advantage, the heat exchange efficiency is improved by employing the structure wherein the heat transfer fluid always passes through the magnetocaloric material.

[0018] As a fourth advantage, the leakage of the heat transfer fluid and the magnetocaloric material is prevented by using the mesh and the plastic packing.

[0019] As a fifth advantage, the heat exchange efficiency is doubled using the four AMR.

[0020] As a sixth advantage, an adiabatic state is achieved by employing the plastic AMR and by preventing an exposure of the magnetocaloric material to outside, resulting in the improvement of the heat exchange efficiency.

[0021] As a seventh advantage, since the through-hole of the AMR bed has the upper and the lower through-holes divided by the ribbed compartment, the distortion of a shape of the AMR due to the pressure of the heat transfer fluid is prevented. Even when the distortion occurs, the heat transfer fluid cannot bypass the magnetocaloric material due to the stricture of the distribution chamber, resulting in the high heat exchange efficiency.

[0022] As the eighth advantage, since the inlet/outlet of the AMR nozzle is right-angled to be on the same plane as the AMR such that the interference of the rotation of the magnet member occurring due to a size of a nipple for flowing the heat transfer fluid into the magnetocaloric material which is larger than a distance between the magnets is prevented and the radius of the rotation of is minimized to be used in the small space.

BRIEF DESCRIPTION OF THE DRAWINGS

[0023] FIG. 1 is a schematic diagram a conventional active magnetic refrigerator.

[0024] FIG. 2 is a schematic diagram illustrating a configuration of a conventional active magnetic refrigerator.

[0025] FIG. 3 is a cross-sectional diagram illustrating an AMR bed of the conventional active magnetic refrigerator of FIG. 2.

[0026] FIG. 4 is a perspective view schematically illustrating a rotation type regenerator in accordance with a preferred embodiment of the present invention.

[0027] FIG. 5 is a perspective disassembled view illustrating a main portion of an AMR of FIG. 4.

[0028] FIGS. 6 through 14 are diagrams illustrating a cycle of a magnetic refrigerator.

DESCRIPTION OF REFERENCE NUMERALS

- [0029] 40,140: pump
- [0030] 60,160: cold-side heat exchangers
- [0031] 70,170: hot-side heat exchangers
- [0032] 100: regenerator
- [0033] 110 (110A, 110B): AMR
- [0034] 111: AMR bed
- [0035] 114: through-hole
- [0036] 115: mounting groove
- [0037] 120L: cold-side AMR nozzle connector
- [0038] 120H: hot-side AMR nozzle connector
- [0039] 121L: cold-side inlet
- [0040] 121H: hot-side inlet
- [0041] 123L: cold-side distribution chamber
- [0042] 123H: hot-side distribution chamber
- [0043] 150: tower
- [0044] 210: magnet member
- [0045] 211: magnet
- [0046] 213: body
- [0047] 230: rotating plate
- [0048] M: mesh
- [0049] R: ribbed compartment
- [0050] S: packing
- [0051] SOL1-SOL4: solenoid valves

BEST MODE FOR CARRYING OUT THE INVENTION

[0052] The above-described objects and other objects and characteristics and advantages of the present invention will now be described in detail with reference to the accompanied drawings.

[0053] FIG. 4 is a perspective view schematically illustrating a rotation type regenerator in accordance with a preferred embodiment of the present invention, FIG. 5 is a perspective disassembled view illustrating a main portion of an AMR of FIG. 4, and FIGS. 6 through 14 are diagrams illustrating a cycle of a magnetic refrigerator. As shown in FIGS. 4 through 14, a magnetic refrigerator in accordance with a preferred embodiment of the present invention comprises a regenerator 100, a cold-side heat exchanger 160 and a hot-side heat exchanger 170 thermally connected to the regenerator 100. While the cold-side heat exchanger 160 performs a cooling, the hot-side heat exchanger 170 performs a heat emission.

[0054] As shown in FIGS. 4 and 5, the regenerator 100 comprises an AMR 110, a magnet member 210 and a magnet rotating assembly for applying or erasing a magnetic field to the AMR 110.

[0055] The AMR 110 comprises a first AMR 110A and a second AMR 110B. As shown in FIG. 5, each of the AMR 110 comprises an AMR bed 111 including the magnetocaloric material for passing through a flow of the heat transfer fluid, a cold-side AMR nozzle connector 120L and a hot-side AMR nozzle connector 120L attached to both sides of the AMR bed the AMR bed 111.

[0056] A through-hole 114 to be filled up with the magnetocaloric material is formed in the AMR bed 111 along a lengthwise direction thereof. In addition, the cold-side AMR nozzle connector 120L and the hot-side AMR nozzle connector 120L are attached to the through-hole 114.

[0057] In addition, a cold-side inlet **121L** and a cold-side distribution chamber **123L** are disposed at each end of the cold-side AMR nozzle connector **120L**, and a hot-side inlet **121H** and a hot-side distribution chamber **123H** are disposed at each end of the hot-side AMR nozzle connector **120H**. The distribution chambers **123L** and **123H** serve as a distribution chamber for uniform distribution through entire cross-section of a flow path of the through-hole **114**. Therefore, a partial contact with the magnetocaloric material and a corrugated shape is minimized to improve the heat exchange efficiency since the heat transfer fluid proceeds at the cold-side inlet **121L** or the hot-side inlet **121H** at a sufficient velocity to be diffused at the distribution chambers **123L** and **123H**, thereby flowing through the entire the through-hole **114**. In addition, the cold-side inlet **121L** and the hot-side inlet **121H** are connected to heat exchange tubes **132** and **134**.

[0058] A plurality of the first AMR **110A** are mounted at an opposing position, and a plurality of the second AMR **110B** are mounted between the first AMR **110A**, i.e. a cross structure.

[0059] Due to the cross structure, when an AMR bed **111A** is in a magnet **211**, an AMR bed **111** is position outside the magnet **211**. A reason that a space exists between the AMR bed **111A** and the AMR bed **111B** is that the heat transfer fluid should not flow when the AMR bed **111** is outside the magnetic field. That is, the AMR bed **111B** is cooled when the AMR bed **111A** is heated.

[0060] Due to an above-described structure of the AMR **110**, the heat transfer fluid always passes through the magnetocaloric material, thereby improving the heat exchange efficiency.

[0061] In addition, it is preferable that the AMR beds **111A** and **111B** or the entire AMR bed **111** comprises a plastic. The plastic has a large adiabatic effect and a wide temperature slope.

[0062] On the other hand, the through-hole **114** comprises an upper through-hole UP and a lower through-hole LP divided by a ribbed compartment R. The ribbed compartment R serves a function of a rib such that the ribbed compartment R prevents a distortion of the AMR bed **111** due to a pressure.

[0063] It is preferable that a mesh M and plastic packing S are mounted at a mounting groove **115** of the through-hole **114** in order to prevent a leakage of the magnetocaloric material and the heat transfer fluid.

[0064] The cold-side heat exchanger **160** and the hot-side heat exchanger **170** are thermally coupled to the AMR **110** through heat exchange tubes **132**, **133**, **134**, **135** and **136**. The flow of the heat transfer fluid is formed by a pump **140**. In addition, a change of a direction of the heat transfer fluid is carried out by solenoid valves SOL1 through SOL4. Moreover, a bypass tube the bypass tube **137** is connected between an inlet and an outlet of the pump **140**.

[0065] The magnet member **210** comprises the magnet **211** and a body **213** for supporting the magnet **211**.

[0066] The magnet rotating assembly comprises a rotating plate **230** for supporting the magnet member **210** and a rotational power transfer member (not shown) for transferring a rotational power to the rotating plate **230**. The rotational power transfer member may be embodied various components such as a gear, a belt and a motor.

[0067] It is preferable that the AMR bed **111** is supported in a horizontal direction perpendicular to a vertical tower **150** such that the AMR bed **111** may move between the magnet **211**.

[0068] It is preferable that the cold-side inlet **121L** and the hot-side inlet **121H** of the cold-side AMR nozzle connector **120L** and the hot-side AMR nozzle connector **120H** are right-angled toward a vertical tower **150** such that the cold-side inlet **121L** and the hot-side inlet **121H** lie on a same plane as the AMR bed **111**. This is to prevent an interference of a rotation of the magnet member occurring due to a size of a nipple for flowing the heat transfer fluid into the magnetocaloric material which is larger than a distance between the magnets. In addition, the magnet member **210** may be used in a small space when a radius of a rotation is minimized.

[0069] The cyclic operation of the magnetic refrigerator in accordance with the preferred embodiment of the present invention will now be described with reference to FIGS. **6** through **14**. It should be noted that the solenoid valves shown in FIGS. **6** through **14** switches in a manner that the solenoid valves operates as an elbow type when OFF and as a straight type when ON.

[0070] FIG. **6** illustrates a state wherein the two magnet members **210** are accurately positioned at the space between the first AMR **110A** and the second AMR **110B**. It is preferable that the magnet members **210** have an angle of 180 therebetween. Since the heat transfer fluid should not flow in the first AMR **110A** and the second AMR **110B** in FIG. **1**, the solenoid valves SOL1 through SOL4 are OFF, and the heat transfer fluid is bypassed though the solenoid valve SOL3 and the solenoid valve SOL4 coupled to the bypass tube **137**.

[0071] As shown FIGS. **7** and **8**, while a plurality of the first AMRs **110A** are in the magnet **211**, a plurality of the second AMRs **110B** are completely out of the magnet **211**.

[0072] Therefore, the heat transfer fluid having the atmospheric temperature that has passed through the hot-side heat exchanger **170** is cooled by passing through the second AMR **110B** via the heat exchange tube **132**, and the heat transfer fluid is cooled additionally by passing through the opposing second AMR **110B**, thereby providing a dual-cooling effect. The temperature of the dual-cooled heat transfer fluid returns to the atmospheric temperature (actually, to a temperature a little lower than the atmospheric temperature) by passing through the cold-side heat exchanger **160** to be subjected to a first heating by passing through the first AMR **110A** and to a second heating by passing through the opposing first AMR **110A**. The heat transfer fluid that has passed through the opposing first AMR **110A** is subjected to the dual-cooling and flows to the pump **140** through the heat exchange tube **134** and the heat exchange tube **135**. The heat transfer fluid passes through the pump **140** and the hot-side heat exchanger **170** to return to the atmospheric temperature (actually, to a temperature a little higher than the atmospheric temperature). The heat transfer fluid is then enters the AMR **110B**. The above-described process forms a single cycle. FIG. **8** illustrates a state after the plurality of the AMRs **110A** is in the magnet **211** completely and before the plurality of the AMRs **110A** move out of the magnet **211** while the heat transfer fluid flows in a direction described above. At this time, the solenoid valve SOL2 is OFF and the solenoid valves SOL1, SOL3 and SOL4 are ON, wherein a cold-side inlet **121AL** and a hot-side inlet **121AH** of the AMR **110A** serve as a cold-side inlet and a hot-side outlet, a hot-side inlet **121BH** and a cold-side inlet **121BL** of the AMR **101B** serve as the hot-side outlet and the cold-side inlet.

[0073] As shown FIGS. **9** and **10**, the heat transfer fluid does not flow to the AMR **110** from a moment when the

plurality of the AMR 110A starts to move in order to move out of the magnet 211 but bypassed.

[0074] As shown FIGS. 11 and 12, contrary to the cycle show in FIGS. 7 and 8, while the plurality of the AMRs 111B are in the magnet 211, the plurality of the AMRs 110A are completely out of the magnet 211. Therefore, the heat transfer fluid having the atmospheric temperature that has passed through the hot-side heat exchanger 170 is subjected to the dual-cooling by passing through the opposing AMR 110A and the AMR 110A via the heat exchange tube 134, and the heat transfer fluid returns to the atmospheric temperature (actually, to a temperature a little lower than the atmospheric temperature) by passing through the cold-side heat exchanger 160 to be subjected to the dual-heating by passing through the opposing AMR 111B and the AMR 110B and flows to the pump 140 through the heat exchange tube 132 and the heat exchange tube 133. The heat transfer fluid pass through the pump 140 and the hot-side heat exchanger 170 to return to the atmospheric temperature (actually, to a temperature a little higher than the atmospheric temperature) to enter the plurality of the AMR 110A via the heat exchange tube 134. The above-described process forms a single cycle. At this time, the solenoid valve SOL1 is OFF and the solenoid valves SOL2, SOL3 and SOL4 are ON, wherein the cold-side inlet 121AL and the hot-side inlet 121AH of the AMR 110A serve as a cold-side outlet and a hot-side inlet, a hot-side inlet 121BH and a cold-side inlet 121BL of the AMR 110B serve as the hot-side inlet and the cold-side outlet.

[0075] As shown FIGS. 13 and 14, the heat transfer fluid does not flow to the AMR 110 from a moment when the plurality of the AMR 110B starts to move in order to move out of the magnet 211 but bypassed.

[0076] Nine steps of FIGS. 6 through 14 illustrates a half cycle of a total rotational cycle, and the half cycle shown in FIGS. 6 through 14 is repeated until the magnet member 210 returns to an initial position to complete the total rotational cycle.

[0077] An advantage of the cycle of the magnetic refrigerator in accordance with the preferred embodiment of the present invention lies in that the heat exchange efficiency is improved by employing a structure wherein the heat transfer fluid directly passes through the magnetocaloric material, and the four AMRs 110 are connected for more magnetocaloric material, resulting in double cooling effects. In addition, the AMR includes the ribbed compartment which prevents the distortion of a shape of the AMR due to the pressure of the heat transfer fluid. Even when the distortion occurs, the heat transfer fluid cannot bypass the magnetocaloric material due to the structure of the distribution chamber, resulting in a high heat exchange efficiency. Moreover, while the AMR 110 having a shape of a simple plate, the AMR 110 provides the high efficiency and is formed in plastic for an easy molding.

[0078] In addition, since the magnetic refrigerator in accordance with the preferred embodiment of the present invention employs a rotational AMR cycle operation, the high cooling effect is provided due to a temperature slope of a low temperature and a high temperature. As described above, the heat transfer fluid is dual-cooled by passing two AMRs, and dual-heated by passing two AMRs to provide twice the cooling efficiency.

[0079] Moreover, in accordance with a basic characteristic of the cycle, the heat transfer fluid flows from the cold-side to the hot-side when AMR enters into the magnet, and the heat transfer fluid does not flow in the AMR when the AMR moves

out of the magnet. The heat transfer fluid flows from the hot-side to the cold-side when the AMR moves out of the magnet to be cooled.

[0080] In addition, since the hot-side heat exchanger is disposed at the outlet of the pump, the hot-side heat exchanger cools the heat transfer fluid heated by the pump to the atmospheric temperature prior to entering the AMR.

[0081] Moreover, the magnetocaloric material has a characteristic wherein the temperature thereof is changed when the magnetic field is applied. The magnetocaloric material 112 comprises a gadolinium (Gd) of a fine powder type. The gadolinium has pores having a high osmosis to the flow of the heat transfer fluid, and a superior absorption and emission of a heat.

[0082] While the present invention has been particularly shown and described with reference to the preferred embodiment thereof, it will be understood by those skilled in the art that various changes in form and details may be effected therein without departing from the spirit and scope of the invention as defined by the appended claims

INDUSTRIAL APPLICABILITY

[0083] In accordance to present invention, a regenerator and a magnetic refrigerator using the same wherein a heat transfer fluid is dispersed and flown through an entire the magnetic refrigerant material to obtain a superior heat exchange characteristic can be provided.

1. A rotational regenerator, comprising:

a first AMR and a second AMR including a magnetocaloric material for passing through a flow of a heat transfer fluid;

a magnet; and

a magnet rotating assembly for applying or erasing a magnetic field to the magnetocaloric material by disposing the magnet at the first AMR or the second AMR, wherein each of the first AMR and the second AMR comprises an AMR bed disposed in a lengthwise direction of a through-hole being filled up with the magnetocaloric material, and cold-side and hot-side AMR nozzles coupled to the AMR bed and connected to the through-hole, and wherein at least one of the AMR nozzles includes a distribution chamber for uniformly distributing the heat transfer fluid to an entirety of a cross-section of the through-hole.

2. The rotational regenerator in accordance with claim 1, wherein the magnet rotating assembly comprises a body for supporting the magnet disposed upper and lower sides of the first AMR or the second AMR, a rotating plate for supporting the body, and a rotational power transfer member for transferring a rotational power to the rotating plate, and wherein each of the first AMR and the second AMR is supported in a horizontal direction perpendicular to a vertical tower.

3. The rotational regenerator in accordance with claim 2, wherein the distribution chamber is connected to a first end of the AMR nozzle, and an inlet/outlet is formed at a second end thereof, and wherein the inlet/outlet of the AMR nozzle is right-angled such that the inlet/outlet is on a same plane with the first AMR and the second AMR.

4. The rotational regenerator in accordance with claim 1, wherein the first AMR and the second AMR include plastic, respectively.

5. The rotational regenerator in accordance with claim 4, wherein the through-hole comprises an upper through-hole and a lower through-hole divided by a ribbed compartment.

6. The rotational regenerator in accordance with claim 5, wherein a mesh and a packing are disposed between the AMR bed and the AMR nozzle.

7. A magnetic refrigerator, comprising:

a first AMR and a second AMR including a magnetocaloric material for passing through a flow of a heat transfer fluid;

a magnet;

a magnetic rotating assembly for applying or erasing a magnetic field to the magnetocaloric material by disposing the magnet at the first AMR or the second AMR; and

cold-side and hot-side heat exchangers thermally connected to the first AMR and the second AMR,

wherein each of the first AMR and the second AMR comprises an AMR bed disposed in a lengthwise direction of a through-hole being filled up with the magnetocaloric material, and cold-side and hot-side AMR nozzles coupled to the AMR bed and connected to the through-hole, and wherein one of the AMR nozzles includes a distribution chamber for uniformly distributing the heat transfer fluid to an entirety of a cross-section of the through-hole.

8. The magnetic refrigerator in accordance with claim 7, wherein the magnet rotating assembly comprises a body for supporting the magnet disposed upper and lower sides of the first AMR or the second AMR, a rotating plate for supporting the body, and a rotational power transfer member for transferring a rotational power to the rotating plate, and wherein each of the first AMR and the second AMR is supported in a horizontal direction perpendicular to a vertical tower.

9. The magnetic refrigerator in accordance with claim 8, wherein the distribution chamber is connected to a first end of the AMR nozzle, and an inlet/outlet is formed at a second end thereof, and wherein the inlet/outlet of the AMR nozzle is right-angled such that the inlet/outlet is on a same plane with the first AMR and the second AMR.

10. The magnetic refrigerator in accordance with claim 7, wherein the first AMR and the second AMR include plastic, respectively, and wherein a mesh and a packing are disposed between the AMR bed and the AMR nozzle.

11. The magnetic refrigerator in accordance with claim 10, wherein the through-hole comprises an upper through-hole and a lower through-hole divided by a ribbed compartment.

* * * * *