



US 20090240236A1

(19) **United States**

(12) **Patent Application Publication**  
**Fogarty**

(10) **Pub. No.: US 2009/0240236 A1**

(43) **Pub. Date: Sep. 24, 2009**

(54) **REINFORCED MEDICAL TUBING**

**Publication Classification**

(75) Inventor: **Terence M. Fogarty**, Hudson, WI  
(US)

(51) **Int. Cl.**  
*A61M 39/00* (2006.01)  
*F16L 9/14* (2006.01)

Correspondence Address:  
**FAEGRE & BENSON LLP**  
**PATENT DOCKETING - INTELLECTUAL**  
**PROPERTY**  
**2200 WELLS FARGO CENTER, 90 SOUTH SEV-**  
**ENTH STREET**  
**MINNEAPOLIS, MN 55402-3901 (US)**

(52) **U.S. Cl.** ..... **604/533; 138/140**

(57) **ABSTRACT**

(73) Assignee: **Composite Plastic, Inc.**, Hudson,  
WI (US)

A molded spiral reinforced tubing suitable for use in an implantable medical device includes a molded inner layer comprised of an elastomeric material. The molded inner layer includes an inner surface having an inner diameter that defines a lumen and further includes an outer surface having an outer diameter. The outer surface includes one or more recessed pathways formed therein. A continuous reinforcement element is provided within each of the one or more recessed pathways. A molded outer layer comprised of an elastomeric material includes an inner surface having an inner diameter and an outer surface having an outer diameter. The inner surface of the outer layer substantially conforms with the reinforcement element and the outer surface of the inner layer.

(21) Appl. No.: **12/276,761**

(22) Filed: **Nov. 24, 2008**

**Related U.S. Application Data**

(60) Provisional application No. 61/038,206, filed on Mar. 20, 2008.

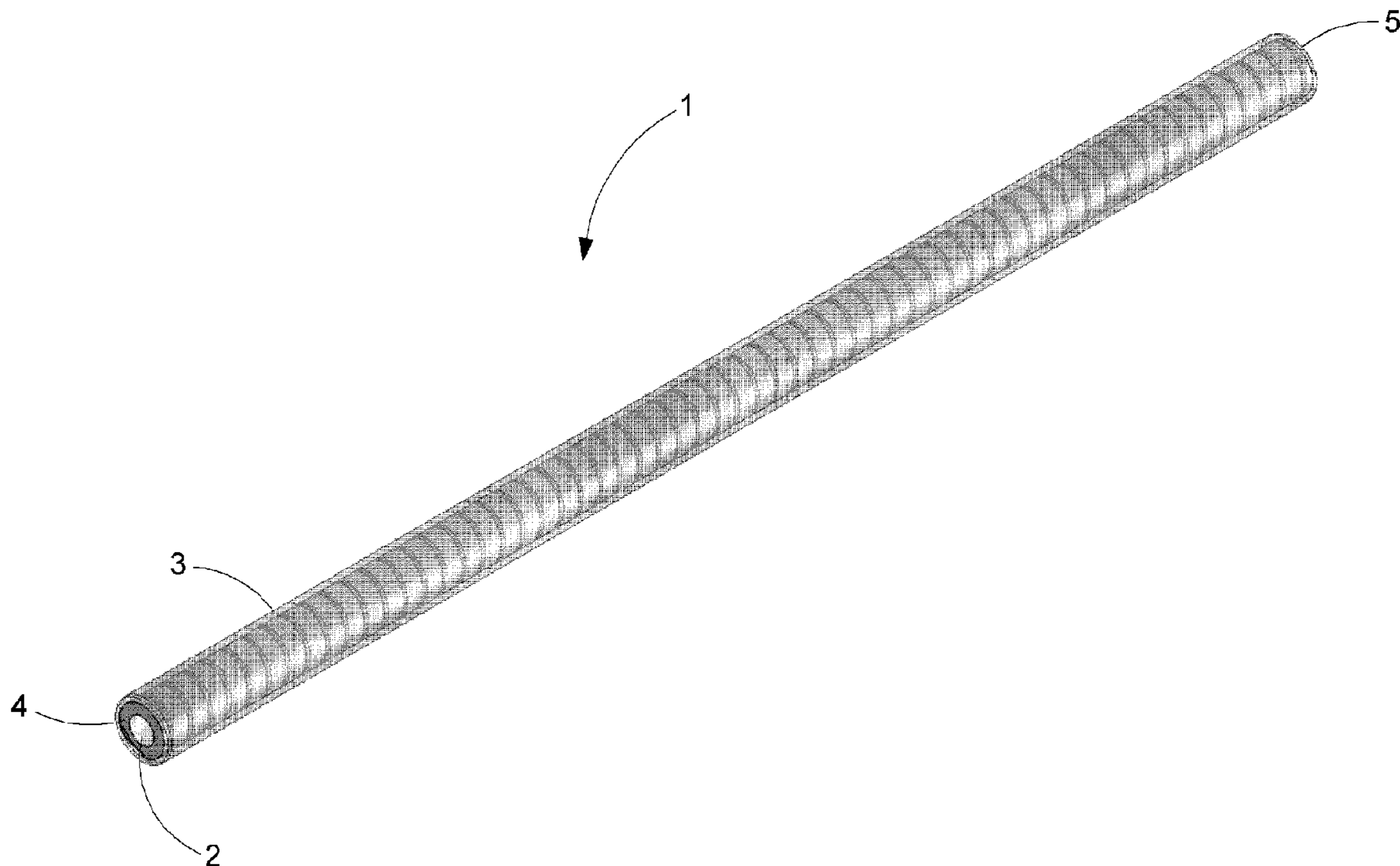

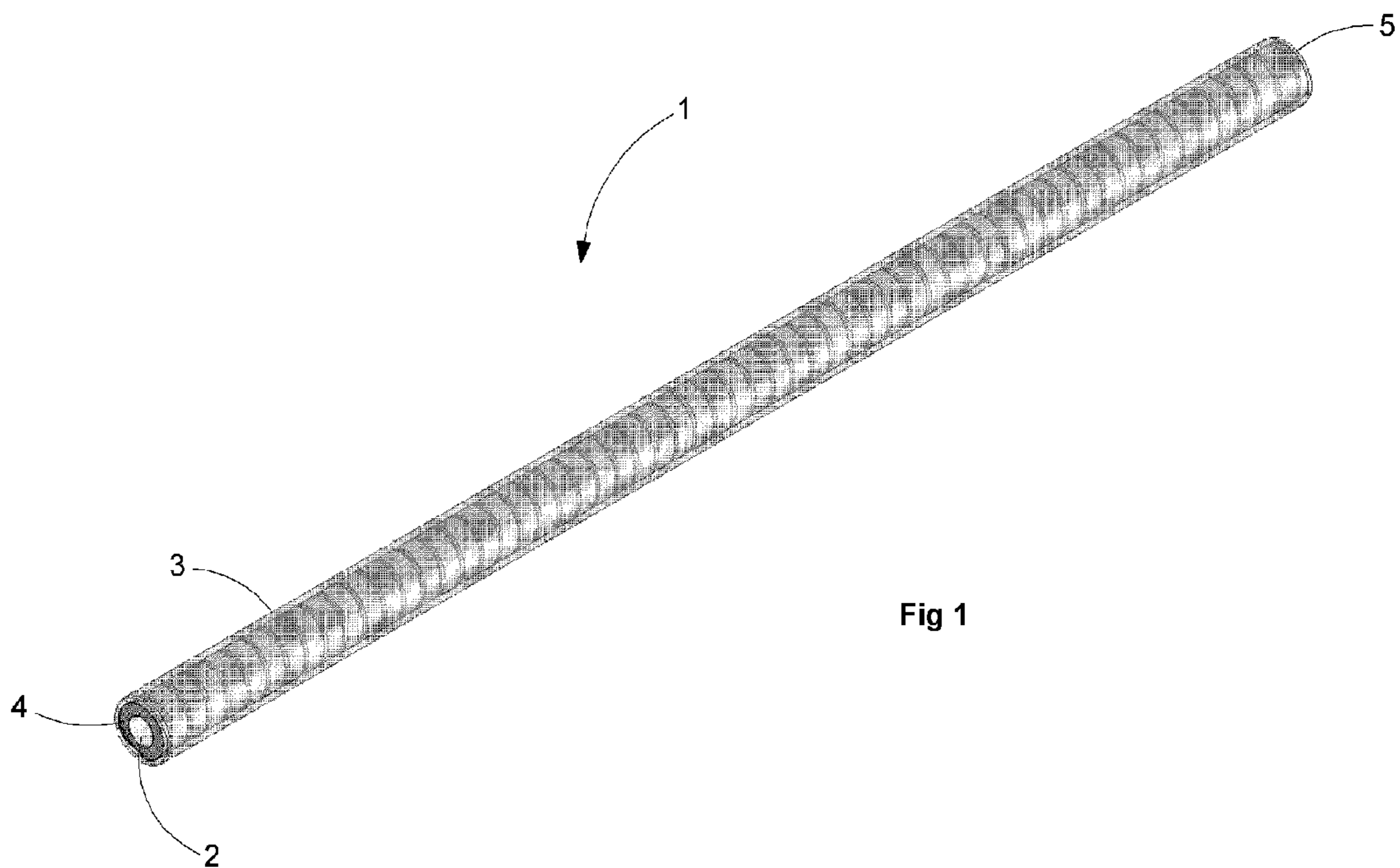

Fig 1

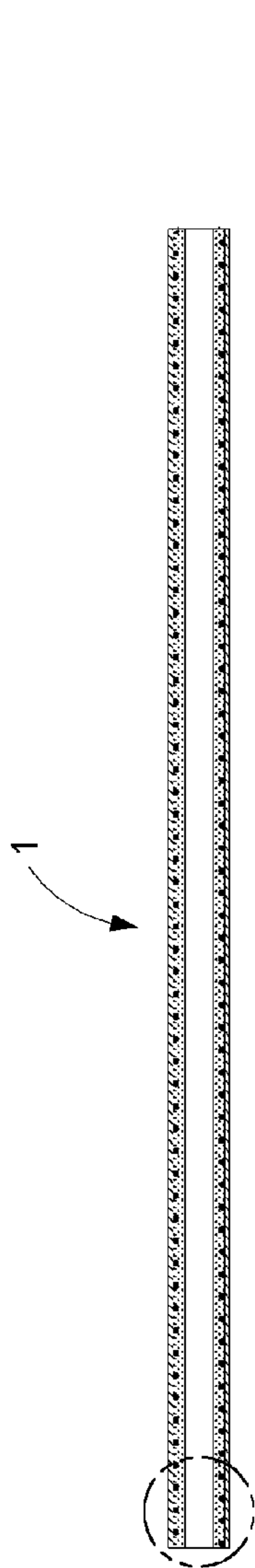

Fig 2

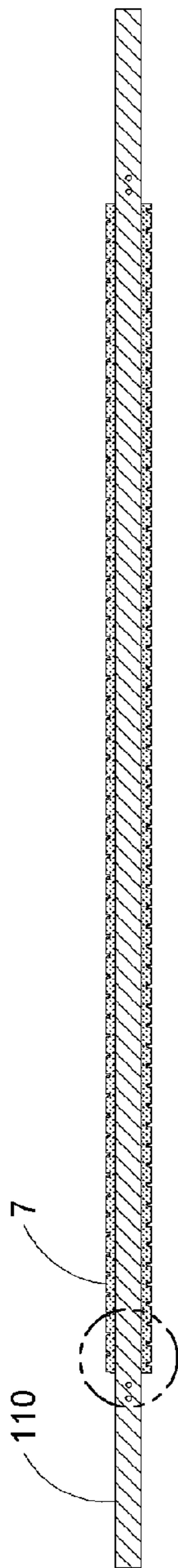

Fig 3

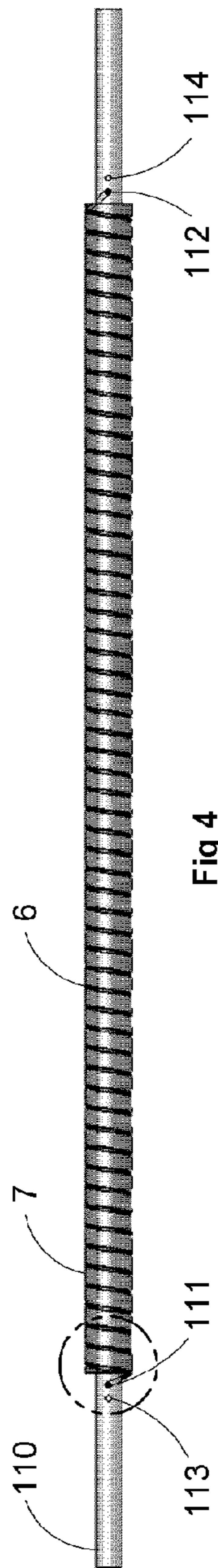

Fig 4

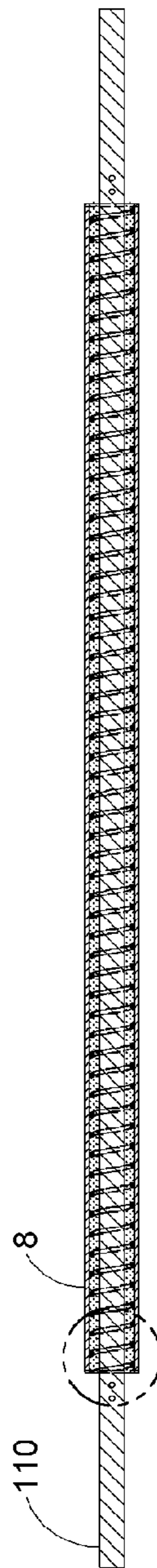

Fig 5

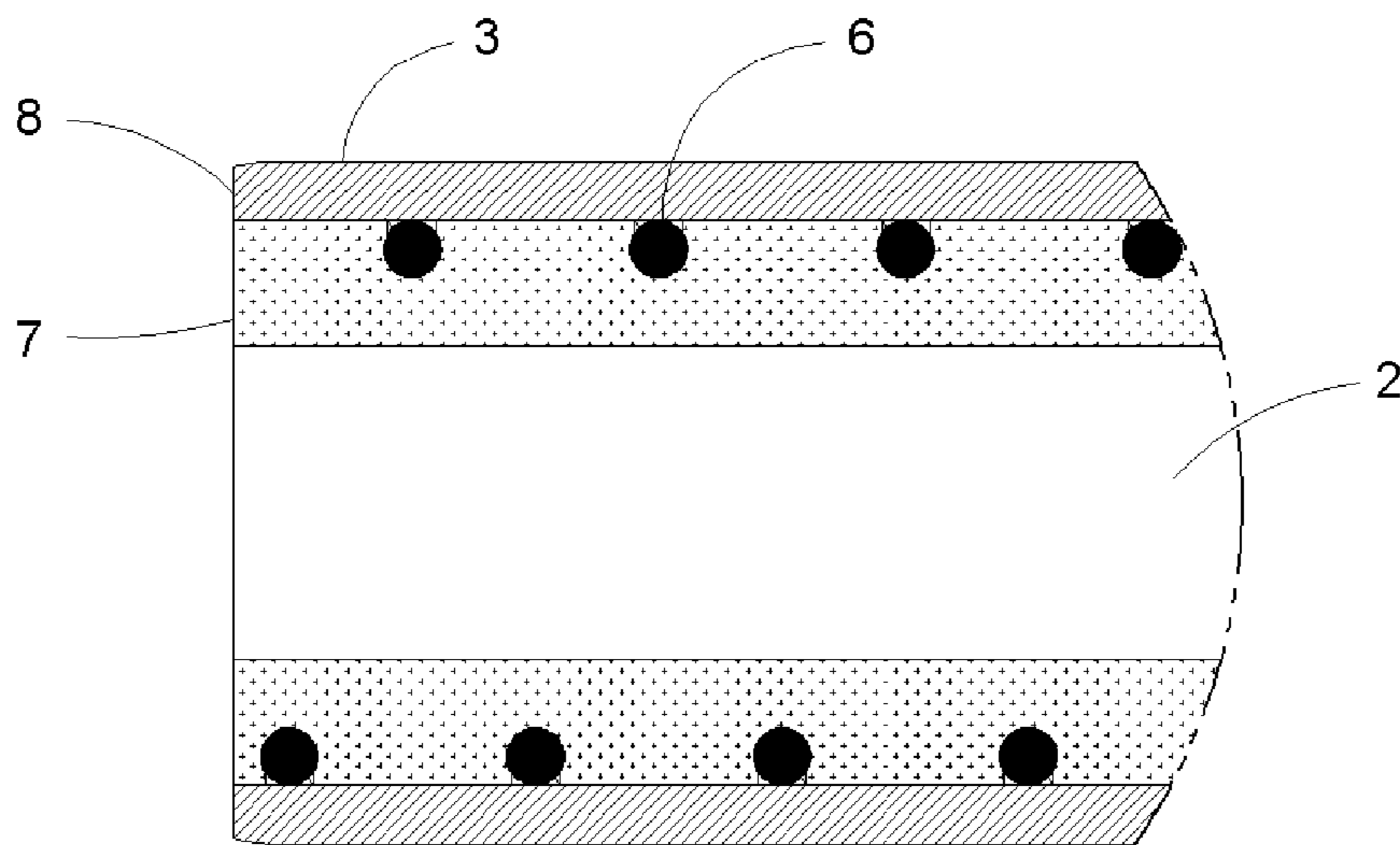

Fig 2a

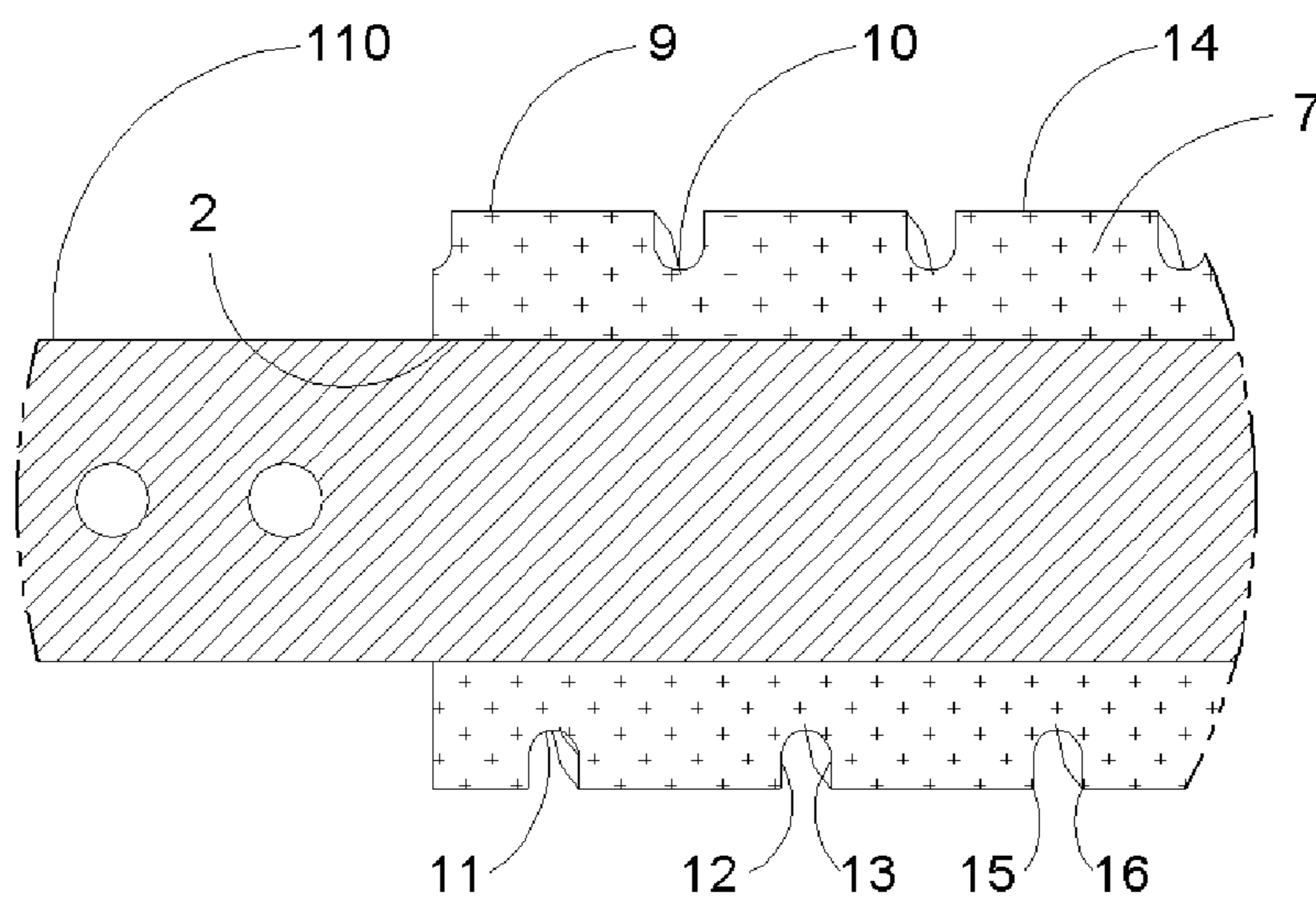

Fig 3a

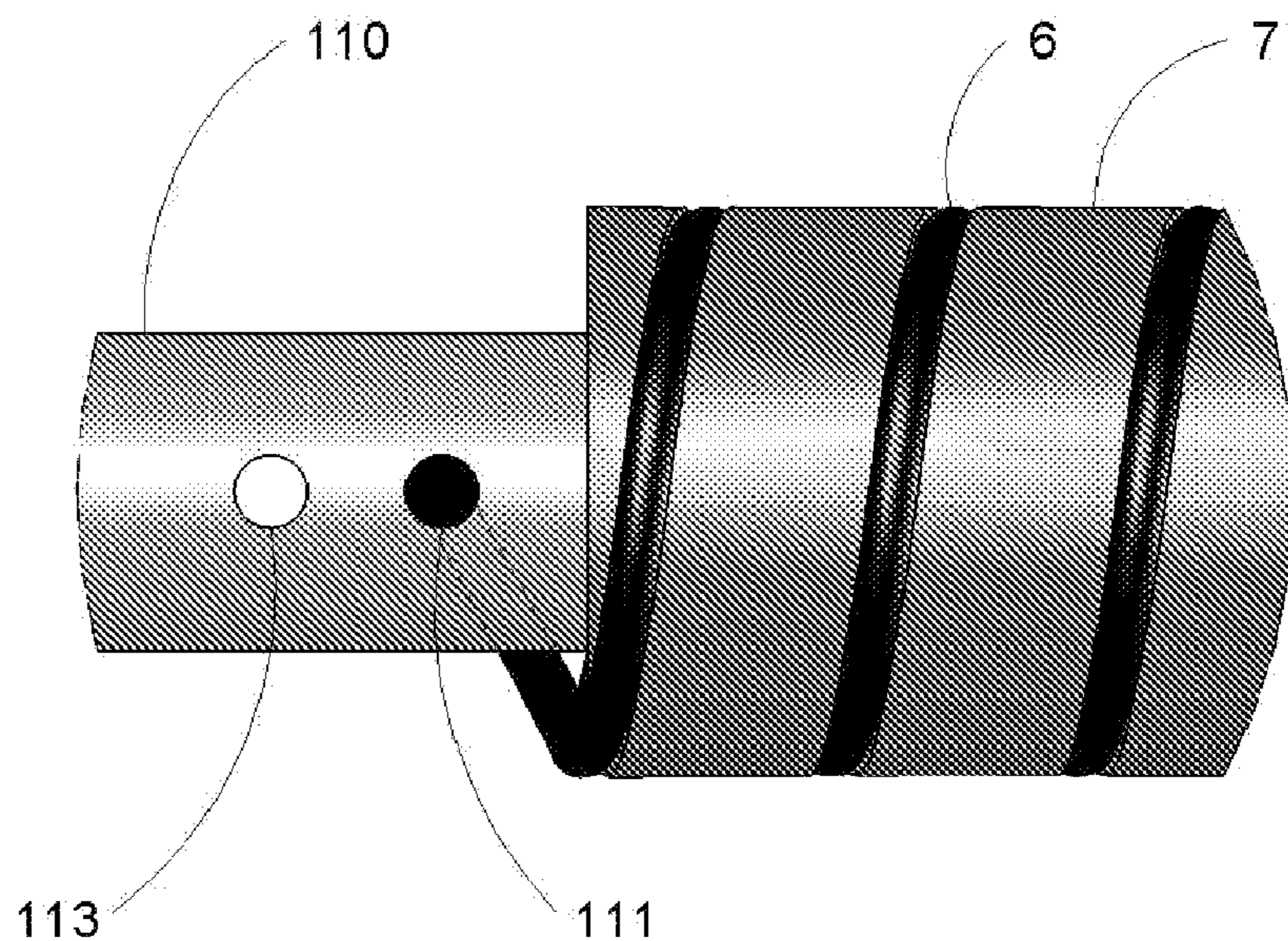

Fig 4a

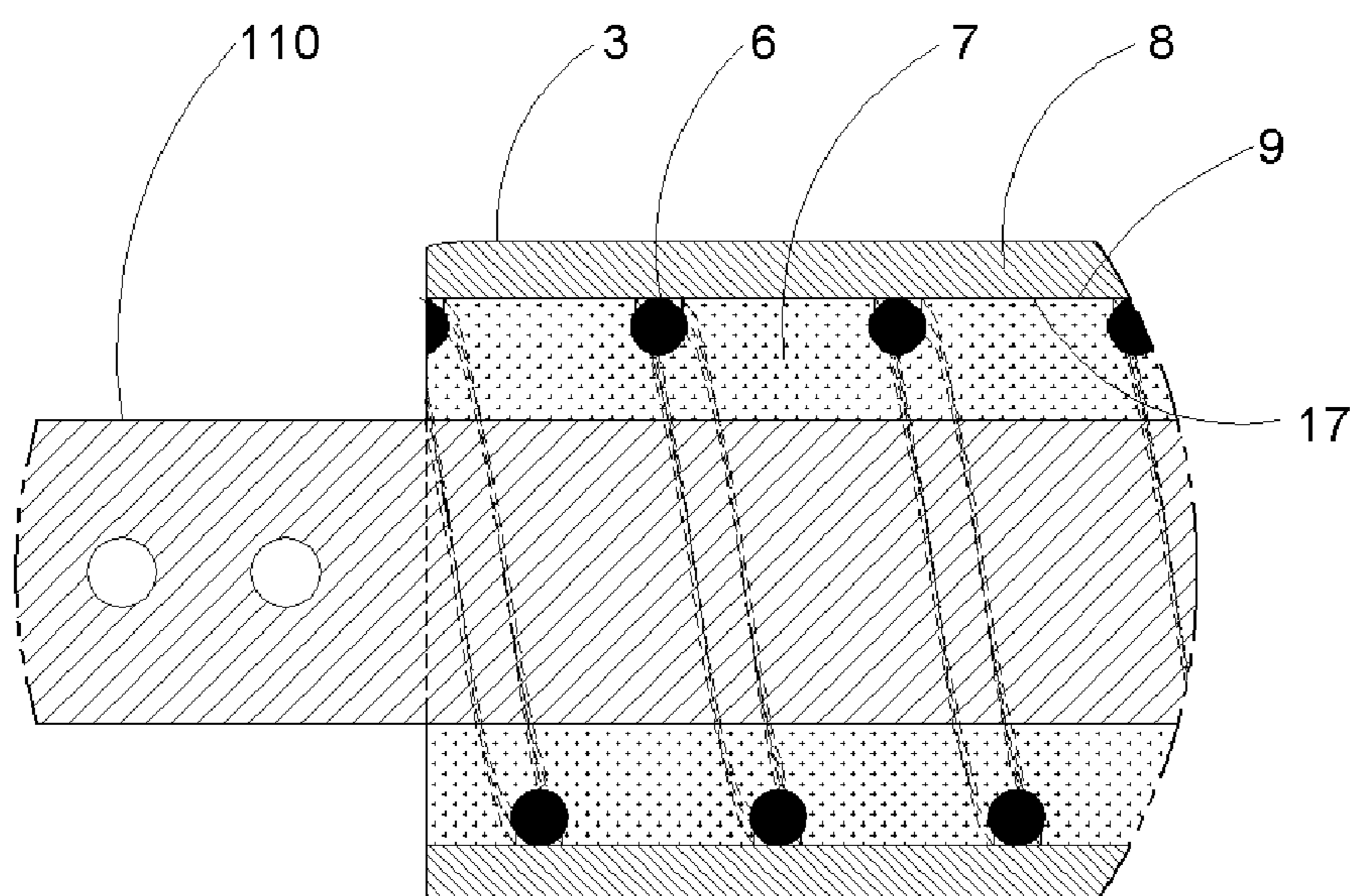

Fig 5a

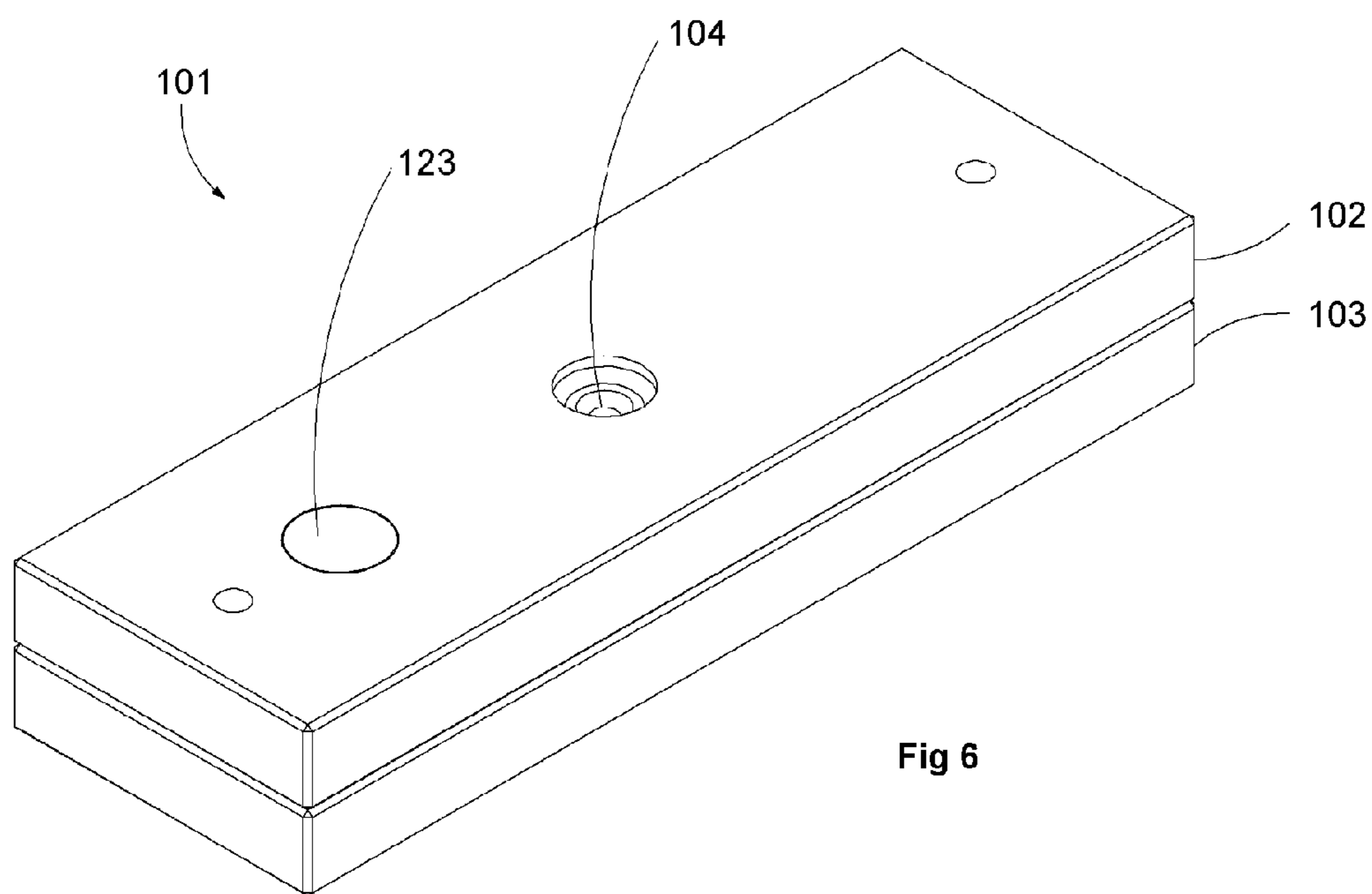

Fig 6

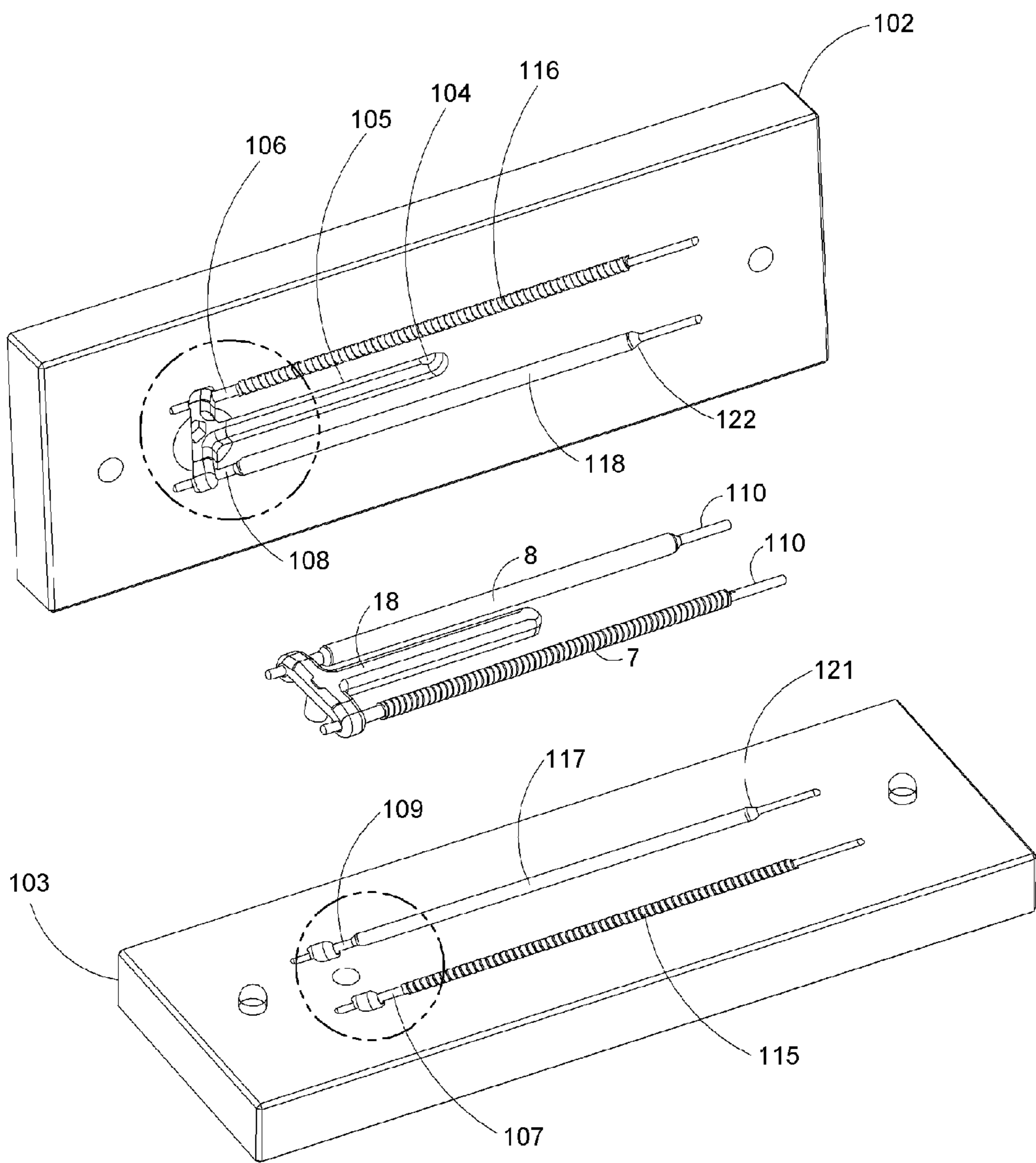

Fig 7

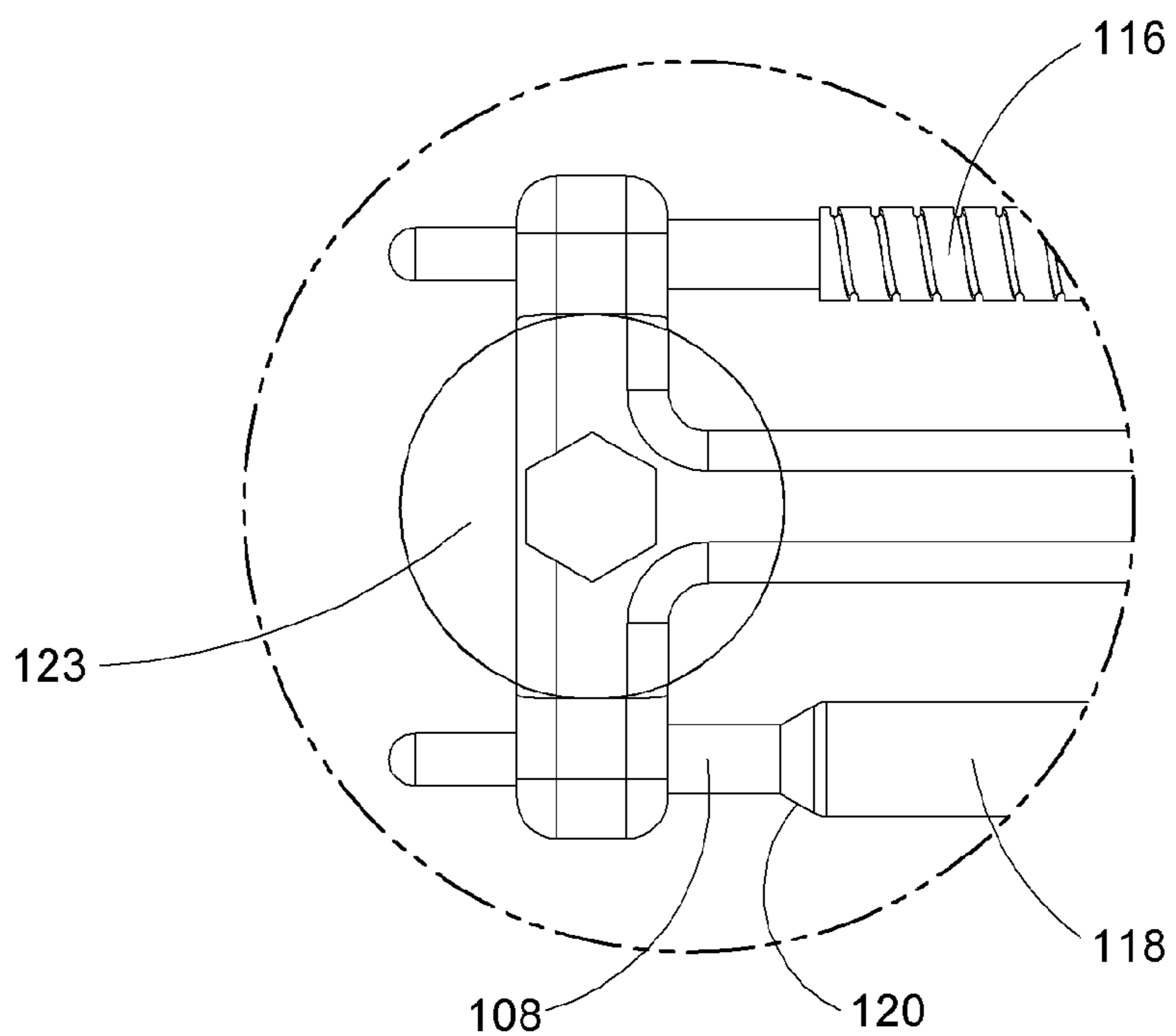

Fig 7b

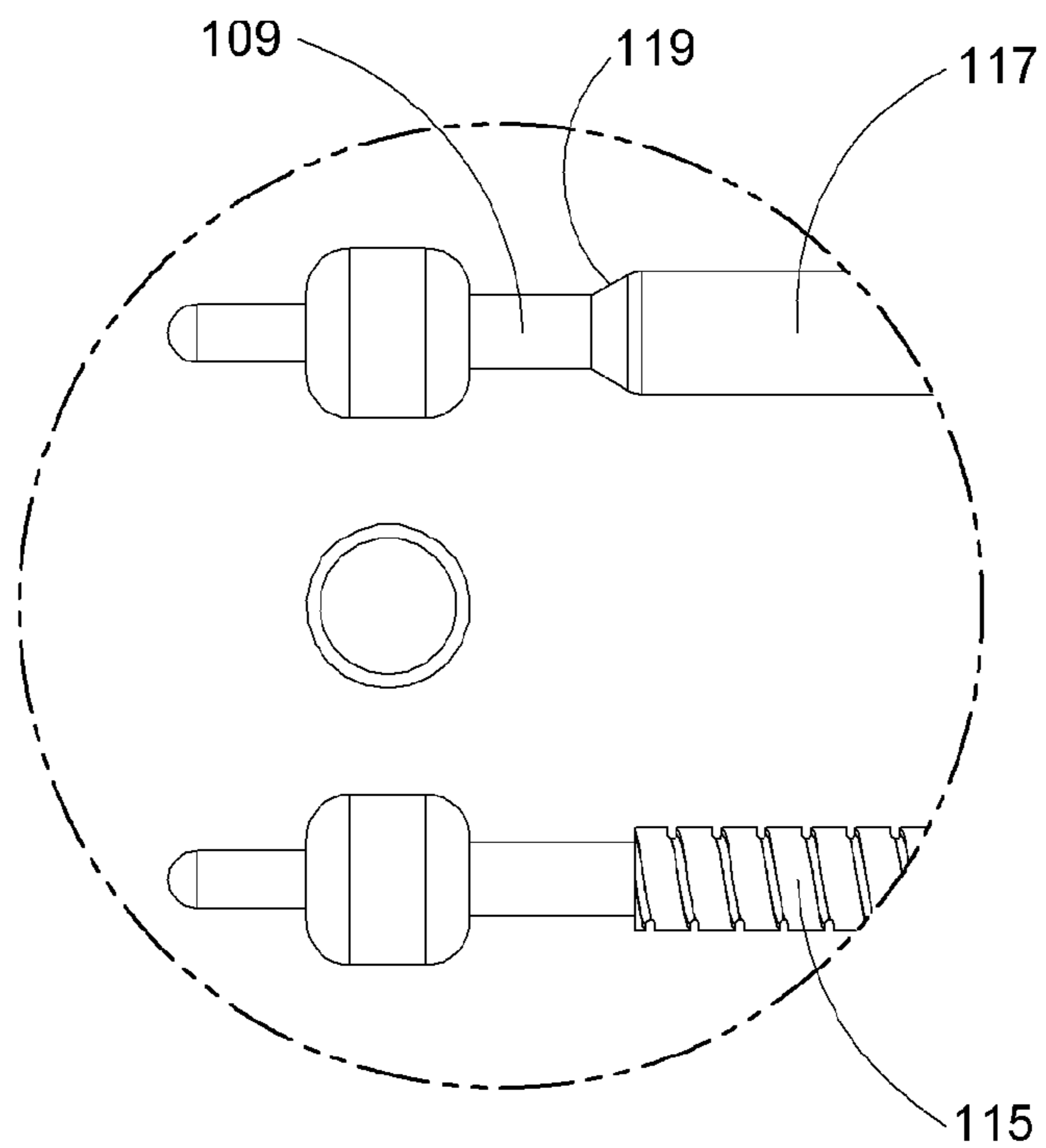
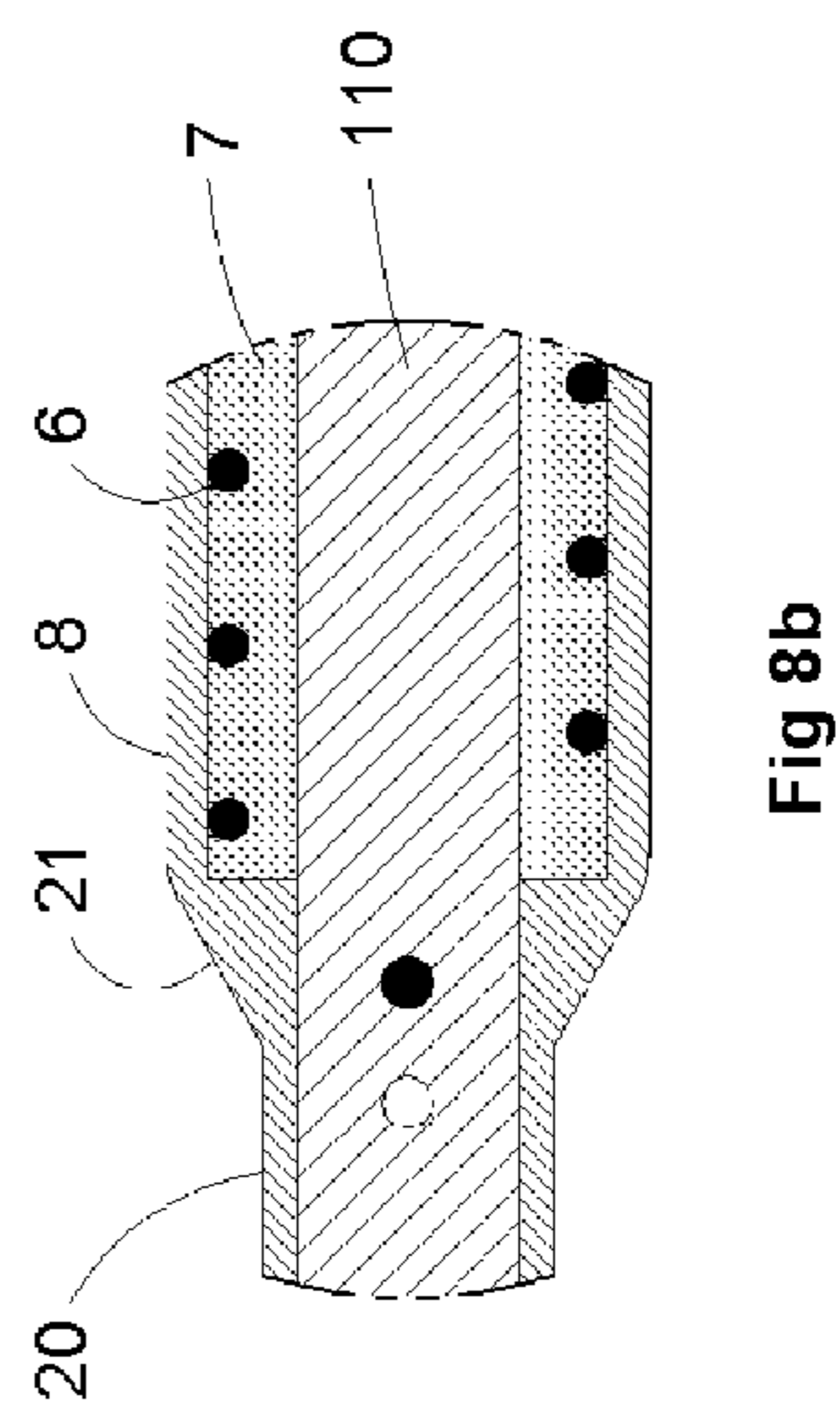
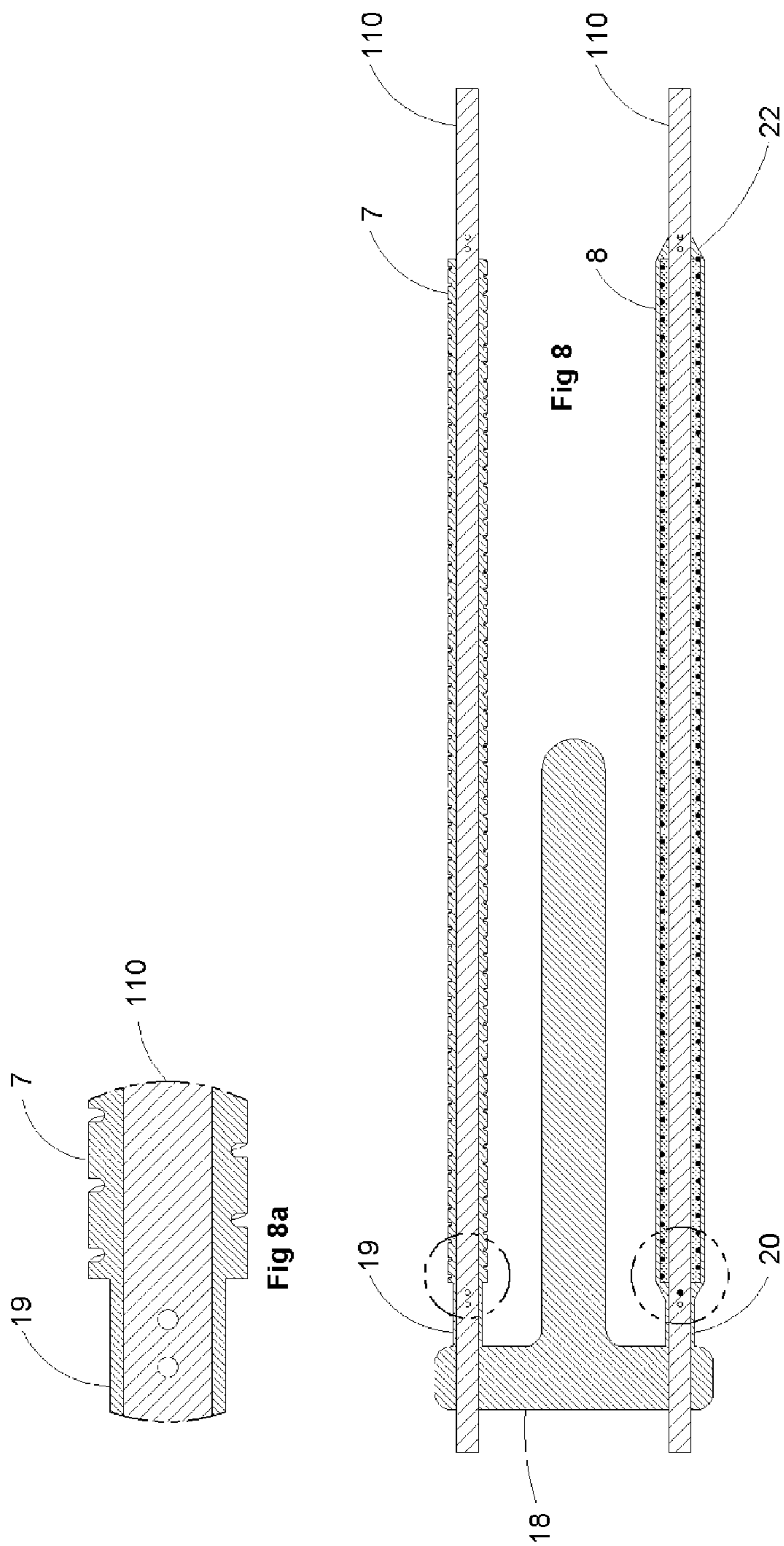

Fig 7a





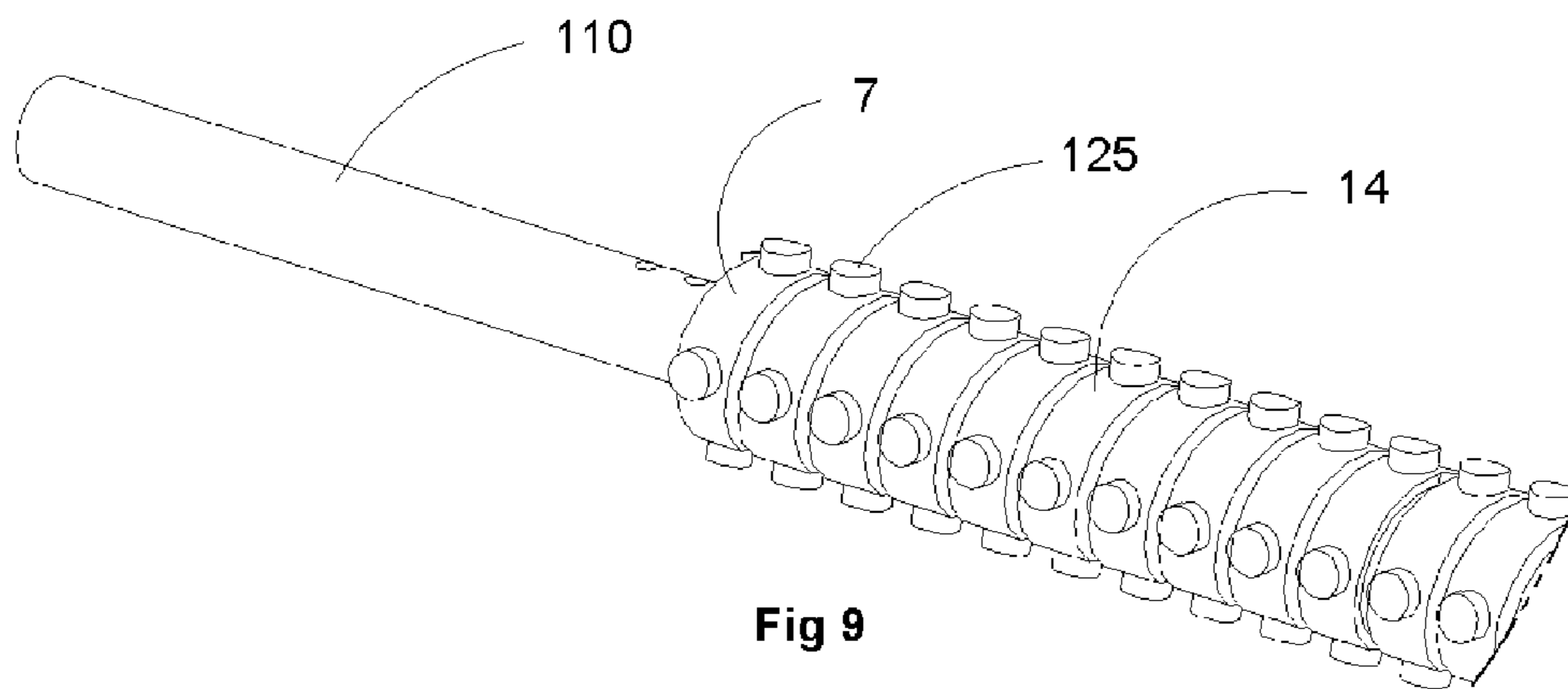

Fig 9

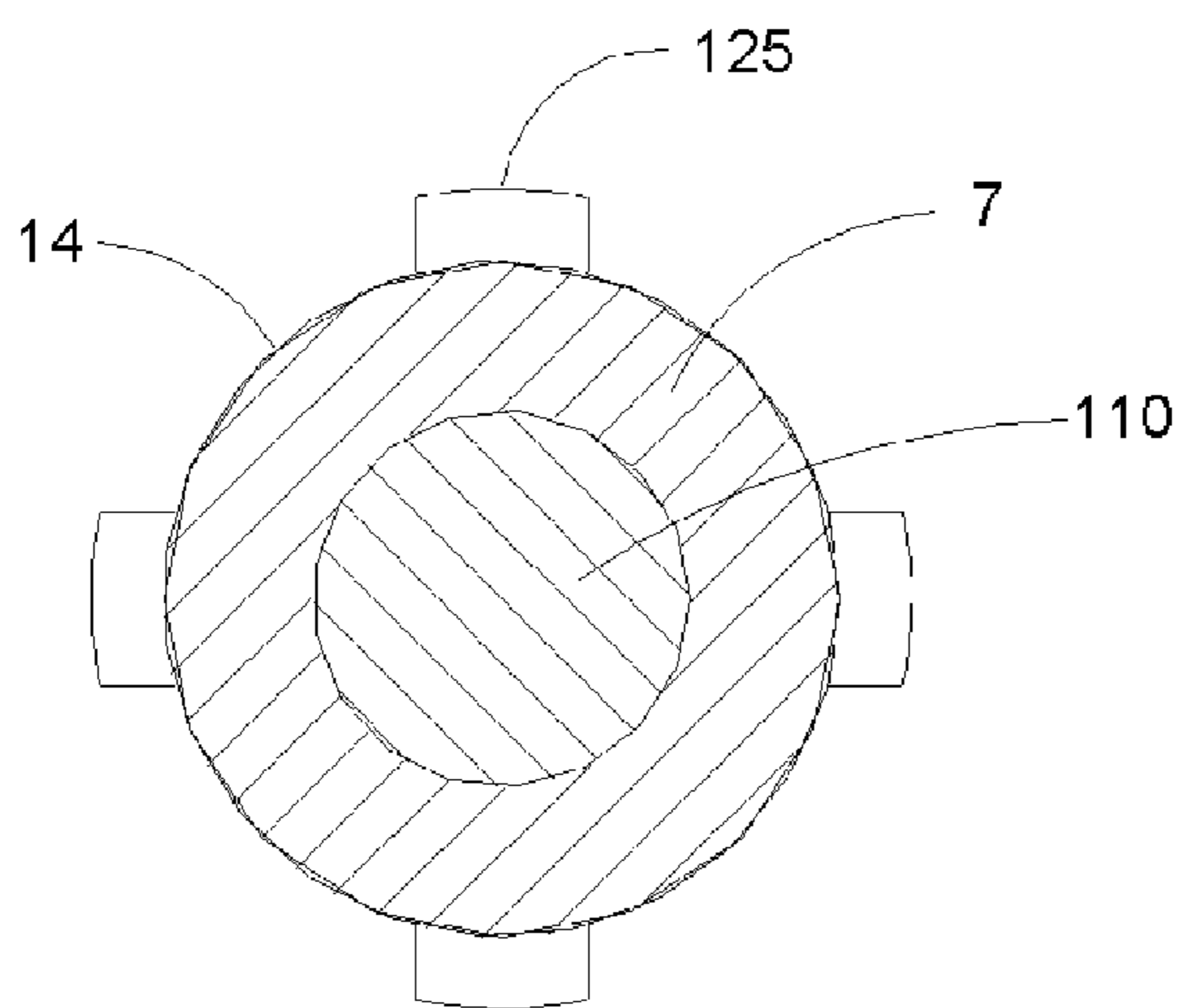
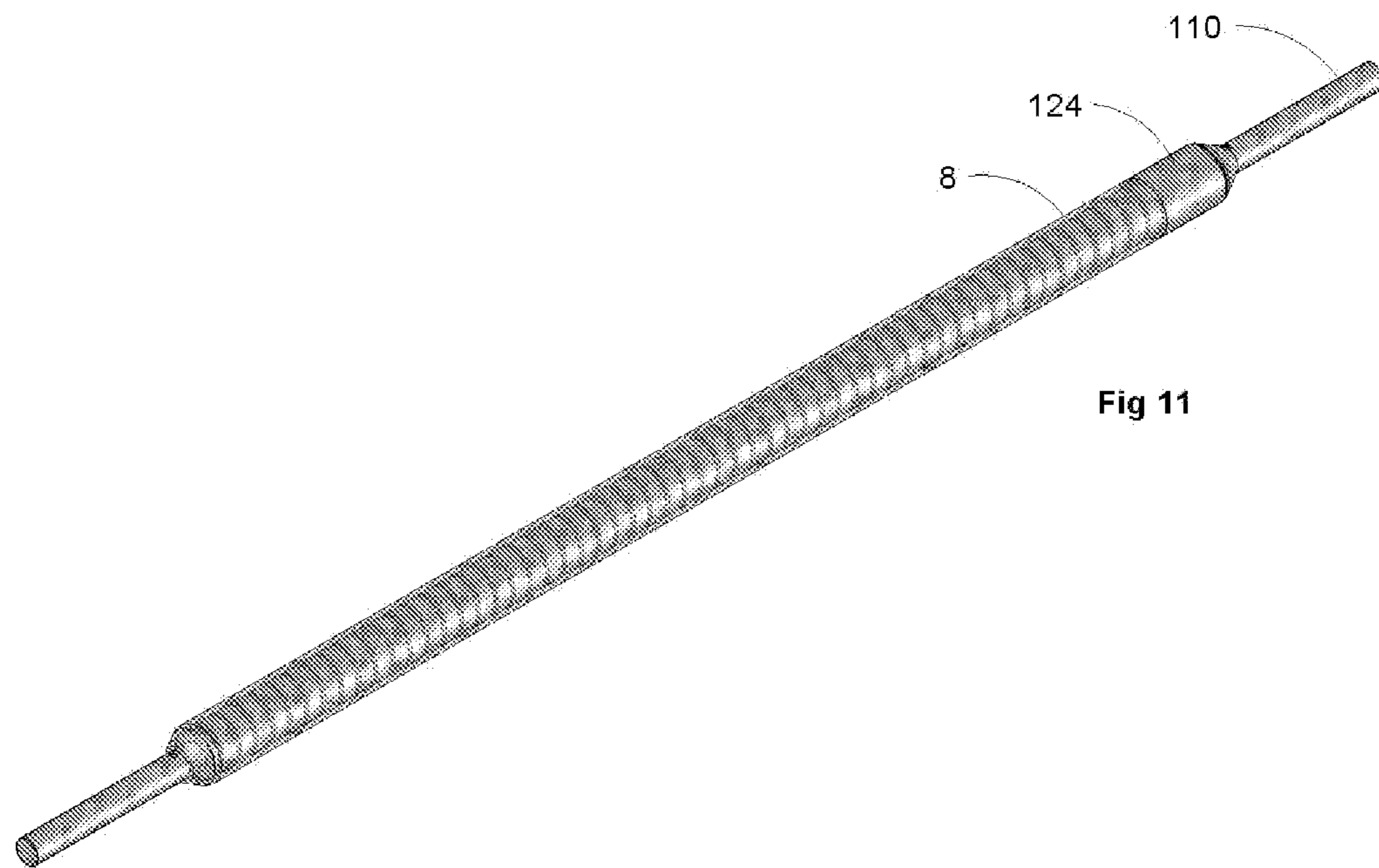
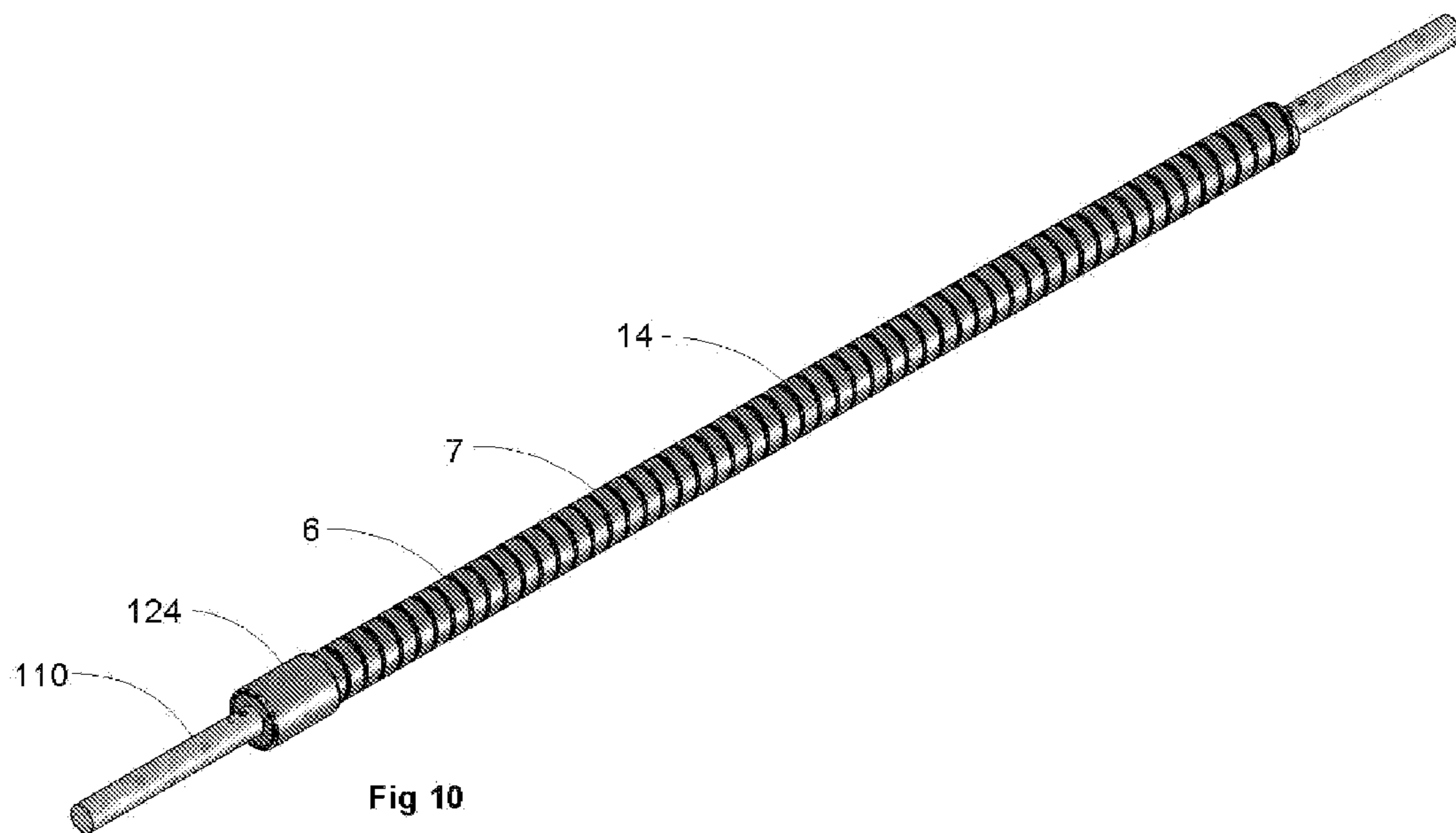

Fig 9a



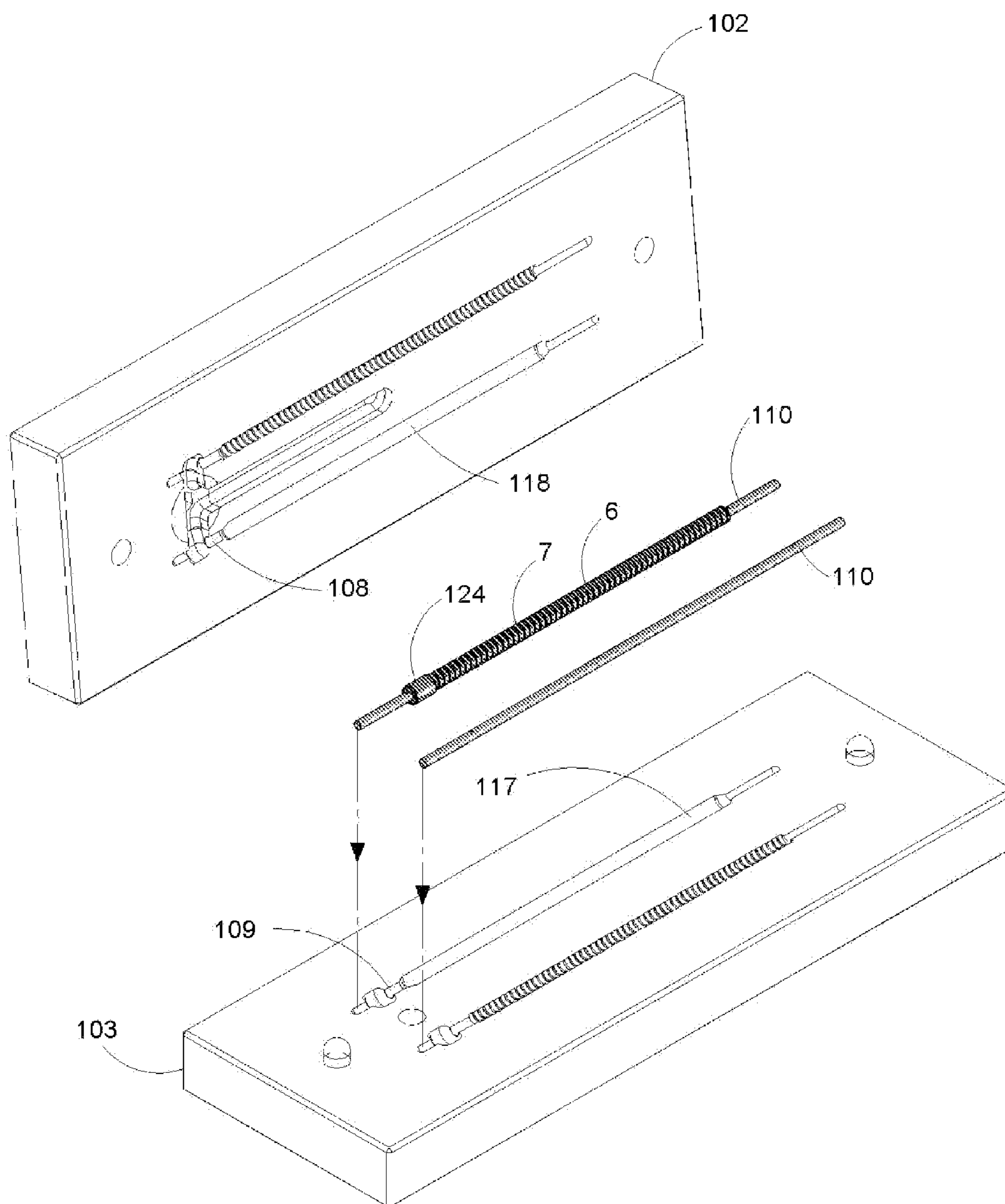

Fig 12

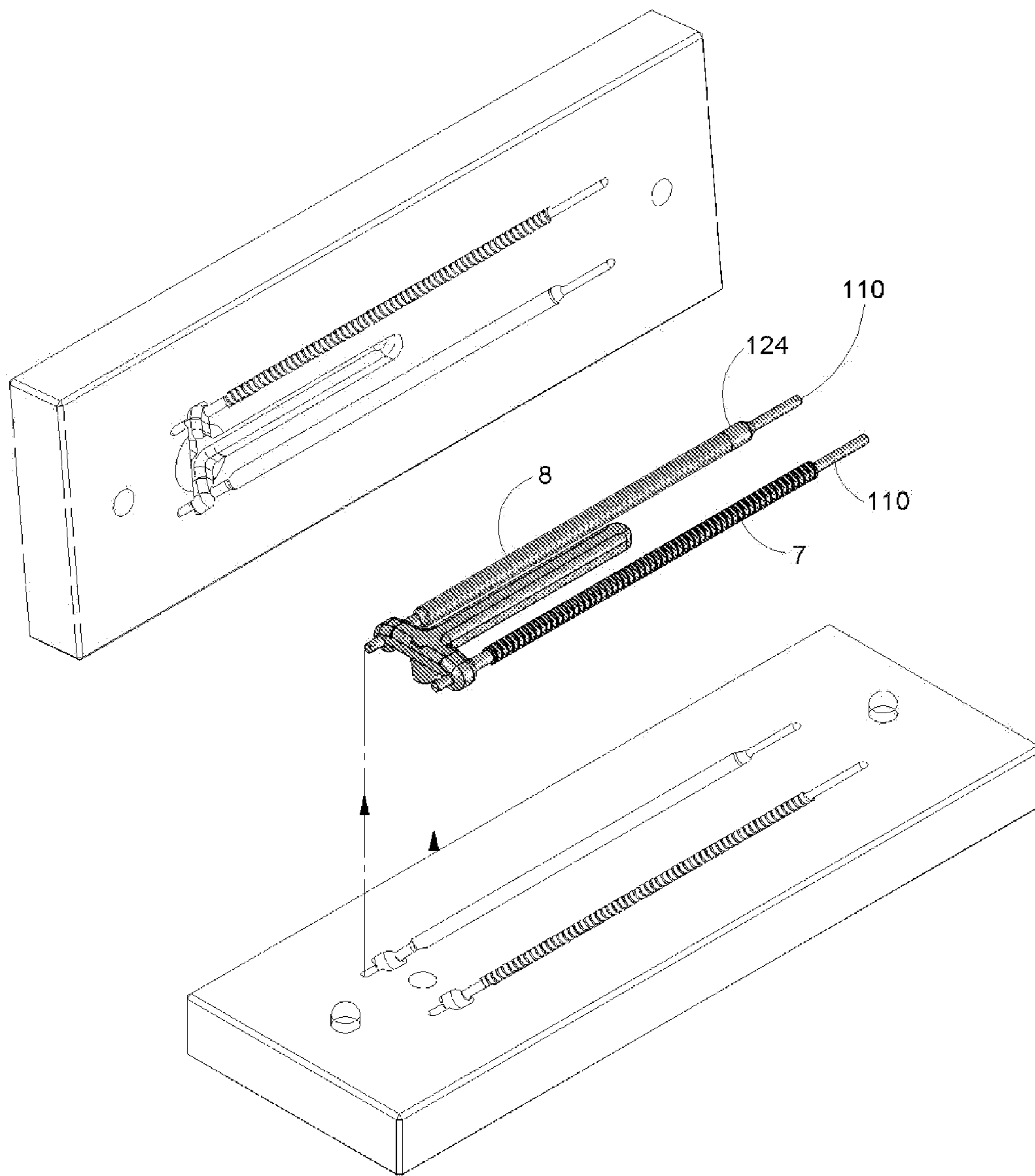

Fig 13

**REINFORCED MEDICAL TUBING****CROSS-REFERENCE TO RELATED APPLICATION**

[0001] This application claims the benefit of provisional application Ser. No. 61/038,206, filed Mar. 20, 2008, entitled "REINFORCED MEDICAL TUBING AND METHOD TO MANUFACTURE," which is incorporated by reference in its entirety. This application is related to co-pending application Ser. No. \_\_\_\_\_, filed on even date herewith, entitled "Method for Manufacturing Reinforced Medical Tubing."

**TECHNICAL FIELD**

[0002] The present invention relates to medical devices. In particular, the present invention relates to a reinforced tubing suitable for use in medical devices.

**BACKGROUND**

[0003] In certain implantable devices, flexible silicone tubing is used to provide a fluid conduit between and connect device components. One such implantable device is a multi-component inflatable penile prosthesis (IPP). In the early 1980's, spiral reinforcement was incorporated in silicone tubing for IPP to provide kink-resistance. Historically, spiral reinforced silicone tubing is fabricated by first extruding and curing an inner layer of silicone elastomer over a core material, wrapping the inner layer of silicone with spiral reinforcement, extruding and curing an outer layer of silicone elastomer over the spiral reinforced inner layer, cutting the tubing and core material to desired lengths, and separating the tubing from the core material.

**SUMMARY**

[0004] The present invention relates to a molded spiral reinforced tubing suitable for use in an implantable medical device. In one embodiment, a molded inner layer comprised of an elastomeric material includes an inner surface having an inner diameter that defines a lumen and further includes an outer surface having an outer diameter. The outer surface includes one or more recessed pathways formed therein. A continuous reinforcement element is provided within each of the one or more recessed pathways. A molded outer layer comprised of an elastomeric material includes an inner surface having an inner diameter and an outer surface having an outer diameter. The inner surface of the outer layer substantially conforms with the reinforcement element and the outer surface of the inner layer.

[0005] While multiple embodiments are disclosed, still other embodiments of the present invention will become apparent to those skilled in the art from the following detailed description, which shows and describes illustrative embodiments of the invention. Accordingly, the drawings and detailed description are to be regarded as illustrative in nature and not restrictive.

**BRIEF DESCRIPTION OF THE DRAWINGS**

[0006] FIG. 1 is an isometric view of a molded spiral reinforced tubing according to embodiments of the present invention.

[0007] FIG. 2 is a cross-sectional view of the molded spiral reinforced tubing shown in FIG. 1.

[0008] FIG. 3 is a cross-sectional view of a core and inner layer of the molded spiral reinforced tubing according to the present invention.

[0009] FIG. 3a is an enlarged cross-sectional view of the core and inner layer shown in FIG. 3.

[0010] FIG. 4 is a plan view of the core and inner layer of the molded spiral reinforced tubing with a reinforcement member according to the present invention.

[0011] FIG. 4a is an enlarged plan view of the core and inner layer with the reinforcement member shown in FIG. 4.

[0012] FIG. 5 is a cross-sectional view of the core and inner layer with an outer layer molded over the inner layer and the reinforcement member according to the present invention.

[0013] FIG. 5a is an enlarged cross-sectional view of the outer layer molded over the inner layer and the reinforcement member shown in FIG. 5.

[0014] FIG. 6 is an isometric view of a transfer mold for molding inner and outer layers of a spiral reinforced tubing according to the present invention.

[0015] FIG. 7 is an isometric view of a transfer mold in an open arrangement showing the mold cavity halves and a molded shot with inner and outer tubing layers.

[0016] FIGS. 7a and 7b are enlarged plan views of portions of the mold cavity halves shown in FIG. 7.

[0017] FIG. 8 is a cross-sectional view of the molded shot with inner and outer tubing layers shown in FIG. 7.

[0018] FIGS. 8a and 8b are enlarged cross-sectional views of portions of the molded shot shown in FIG. 8.

[0019] FIG. 9 is an isometric view of a molded inner layer on the mold core, with multiple centering projections emanating from the outer surface of the inner molded layer according to embodiments of the present invention.

[0020] FIG. 9a is a cross-sectional view of the molded inner layer on the mold core shown in FIG. 9.

[0021] FIG. 10 is an isometric view of a molded inner layer and reinforcement on a mold core, with a centering sleeve installed over the outer surface of the inner molded layer according to embodiments of the present invention.

[0022] FIG. 11 is an isometric view of molded spiral reinforced tubing with the centering sleeve on the mold core after molding the outer layer.

[0023] FIG. 12 is an isometric view of a transfer mold for molding inner and outer layers of a molded spiral reinforced tubing, depicting axial orientation of the centering sleeve over inner layer prior to molding.

[0024] FIG. 13 is an isometric view of a transfer mold for molding inner and outer layers of a molded spiral reinforced tubing, depicting axial orientation of the centering sleeve after molding.

[0025] While the invention is amenable to various modifications and alternative forms, specific embodiments have been shown by way of example in the drawings and are described in detail below. The intention, however, is not to limit the invention to the particular embodiments described. On the contrary, the invention is intended to cover all modifications, equivalents, and alternatives falling within the scope of the invention as defined by the appended claims.

**DETAILED DESCRIPTION**

[0026] FIG. 1 depicts a reinforced tubing 1 according to embodiments of the present invention. FIG. 2 depicts a sectional view of the molded spiral reinforced tubing 1, and FIG. 2a is an enlarged view of a segment from FIG. 2 depicting a single spiral reinforcement member 6, an inner molded layer

7, and an outer molded layer 8. The tubing 1 includes a continuous lumen 2 and an outer surface 3 between tubing ends 4 and 5. As will be described in more detail herein, the tubing 1 is molded and includes a spiral reinforcement. It has utility in a variety of applications where flexible fluid conduit with spiral reinforcement improves performance characteristics by enhancing resistance to deformation from internal or external forces. In some applications, the reinforced tubing 1 may be used in medical devices, since the construction conforms with variations in the patient's anatomy. One example use for tubing 1 in a medical device is as a fluid conduit between components in the medical device. Examples of medical devices that might utilize reinforced tubing 1 as a fluid conduit between components are inflatable penile prostheses, inflatable mammary prostheses, inflatable urinary or fecal incontinence devices, inflatable tissue expanders, and devices utilizing implantable injection ports.

[0027] FIGS. 3-5 illustrate steps in the formation of the spiral reinforced tubing 1 illustrated in FIGS. 1 and 2. FIG. 3 is a sectional view of a core 110 and the inner layer 7 of a molded spiral reinforced tubing 1. FIG. 3a is an enlarged view of the portion circled in FIG. 3 depicting the inner molded layer 7 including the lumen 2 (defined by the diameter of the core 110) and an outer surface 9. The outer surface 9 has a major diameter 14 and includes a recessed pathway 10 for receiving the continuous spiral reinforcement member 6 (not shown in FIGS. 3 and 3a). The pathway 10 includes arc 11 at its base (i.e., the portion of the pathway most proximate to the lumen 2). Surfaces 12 and 13 connect the arc 11 to the outer surface 9. A transition arc 15 may extend between the surface 12 and the outer surface 9, and a transition arc 16 may extend between the surface 13 and the outer surface 9. In some embodiments, the radius of the arc 11 is sized between about 2% and about 40% smaller than the radius of the reinforcement member 6, to retain the reinforcement member 6 in the pathway 10 between the surfaces 12 and 13. More preferably, the radius of the arc 11 is sized between about 10% and about 20% smaller than the radius of the reinforcement member 6. The depth of the pathway 10 (extending from the outer surface 9 to the bottom of the arc 11) is preferably equal to the diameter of the reinforcement member 6.

[0028] FIG. 4 depicts the core 110 and the inner layer 7 of the spiral reinforced tubing 1 with the reinforcement member 6 secured to the core 110. FIG. 4a is an enlarged view of the portion circled in FIG. 4 depicting the inner molded layer 7 and the reinforcement member 6. The core 110 includes crossholes 111 and 112 formed proximate the ends of the core 110. The reinforcement member 6 is spirally wound and deposited into the recessed pathway 10. The ends of the reinforcement member 6 are inserted through the crossholes 111 and 112 of the core 110. The ends of the reinforcement member 6 are secured to the core 110 by mechanical means such as a knot, swedging, heading, or a retention cuff, or the reinforcement member 6 may be tucked between the core 110 and the inner layer 7. If the reinforcement member 6 is metallic in composition, swedging or heading may be accomplished mechanically. If the reinforcement member 6 is a thermoplastic composition, swedging or heading may be accomplished thermally. The core 110 may also have additional crossholes 113 and 114 to facilitate securement of the reinforcement member 6 to the core 110. The reinforcement member 6 is secured to the core 110 by first routing the reinforcement member 6 through the crosshole 111, then through the crosshole 113, then depositing the reinforcement

into the recessed pathway 10, then routing the reinforcement through the crosshole 112, and finally through the crosshole 114. The crossholes 111-114 may penetrate the core 110 in the same or different radial orientations or may be angled so that the crosshole entry and exit may be at different elevations along the axis of the core 110 to ease installation of the reinforcement member 6. The crossholes 111-114 may be tapered to provide a larger opening or entry target to introduce the reinforcement member 6 and a smaller exit to retain the reinforcement member 6. The crossholes 111-114 may be electro-discharge machined (EDM) in the core 110, wherein the shape of each crosshole 111-114 is not limited to a uniform configuration as might be the case with twist drilling.

[0029] In some embodiments, the reinforcement member 6 has a diameter at least 0.002 inch smaller than the diameters of the crossholes 111 and 112. In one actual implementation, a 0.013-inch diameter Nylon 6 monofilament was utilized with a single 0.015-inch diameter crosshole on both ends of core 110.

[0030] The reinforcement member 6 forms a sharp bend as it transitions from the crosshole entry to overlying the circumference of the core 110 that provides a means to retain the reinforcement member 6 in the crosshole. Excess portions of the reinforcement member 6 may be trimmed flush with the exit side of the crossholes 111, 112.

[0031] FIG. 5 depicts a sectional view of the core 110 with the outer tubing layer 8 molded over the inner tubing layer 7 and the reinforcement member 6. FIG. 5a is an enlarged view of the portion circled from FIG. 5 depicting the outer molded layer 8 over the inner molded layer 7 and the reinforcement member 6. The outer molded layer 8 has an outer surface 3 and an inner surface 17. The inner surface 17 is conformal with the reinforcement member 6 and the outer surface 9 of the inner molded layer 7. In some embodiments, the outer molded layer 8 is chemically and mechanically bonded to inner molded layer 7, but not to the reinforcement member 6. Bonding of the molded layers 7 and 8 mechanically retains the reinforcement member 6 between the recessed pathway 10 of the inner layer 7 and the inner surface 17 of the outer layer 8. Materials selected for the outer layer 8 and the reinforcement member 6 prevent bonding of the outer layer 8 to the reinforcement member 6. If necessary, the reinforcement member 6 should be coated to prevent adhesion of the molded outer layer 8 to the reinforcement member 6. Additionally, the reinforcement member 6 may be coated to reduce the surface tension between the molded layers 7 and 8. The reinforcement member 6 should move freely in the recessed pathway 10 when the tubing is flexed, to prevent localized stresses that will reduce fatigue life.

[0032] Components of the spiral reinforced tubing 1 may be molded from a thermoplastic elastomer (e.g., polyurethane or polyvinyl chloride (PVC)), a thermoset elastomer (e.g., silicone or ethylene propylene diene monomer (EPDM)), or a combination of thermoplastic and thermoset elastomers. In certain implantable medical devices, such as implantable penile prostheses (IPP), silicone elastomer may be favored for its biocompatibility and low modulus. In these embodiments, the inner layer 7 is molded from a gum or high-consistency elastomer such as Nusil MED 4755, a platinum cured two-part elastomer. Two-part platinum elastomers have one part containing a catalyst that is mixed with the another part containing a crosslinker. Platinum cured two-part liquid injection molding (LIM) elastomer such as Nusil MED 4850 may also be used for the inner layer. High-consistency elastomers have

good tear resistance, making them particularly suitable for the inner layer 7. The two parts of high consistency silicone elastomer are usually combined on a two-roll mill and molded using either compression or transfer molding methods. Alternatively, the inner layer 7 may be molded with one-part high-consistency elastomer, such as peroxide cured silicone elastomer, that may be compression or transfer molded.

[0033] The outer layer 8 may be molded from a gum or high-consistency elastomer such as Nusil MED 4755 because it has a high tear strength. The surface tension between the core 110 and the inner tubing layer 7 is configured to allow removal of the core 110 after molding, but also to minimize movement of the inner layer 7 on core 110 during overmolding of the outer layer 8. The selected overmolding parameters, such as mold temperature and transfer speed, optimize the elastomer flow over the reinforcement member 6 and inner layer 7.

[0034] The outer layer 8 may also be dispersion coated by dipping or spraying a dispersion grade elastomer. Dispersion grade elastomers can be formulated from peroxide, platinum or acetoxy cure silicone elastomers with a range of solids content using chemical solvents such as xylene, trichloroethane, naphtha, hexane and toluene. Two part elastomers may be converted to dispersions prior to or after combining the two parts. Molding by dispersion coating is considerably slower than molding with gum or LIM elastomers using matched metal molds. The desired thickness of the outer layer 8 may be achieved with multiple dispersion coatings. Subsequent to volatilizing the dispersion solvent, the silicone elastomer is vulcanized. Acetoxy cured elastomers may also be used to provide improved abrasion resistance.

[0035] The reinforcement member 6 may be comprised of a metallic or polymeric material. Examples of metallic reinforcement are AISI 316L, a low carbon steel, or MP35N, a chromium, nickel, molybdenum and cobalt alloy. Metallic reinforcement has significantly higher tensile modulus than plastic reinforcement and can sustain permanent deformation if deformed beyond its elastic limit. The higher modulus metal reinforcement has less fatigue resistance than lower modulus plastic reinforcement. Metal reinforcements may be formed using spring winding equipment prior to placement on the inner layer 7.

[0036] Examples of polymeric materials suitable for reinforcement member 6 are nylon, polyester or polypropylene. Plastic reinforcement may be wound directly onto the tubing inner layer 7. For certain long-term medical applications, such as IPP, plastic reinforcement may be better suited than metal, because it is less susceptible to permanent deformation, more resistant to fatigue and provides a more compliant tubing. In some embodiments, polyamide, commonly referred to as nylon, is favored for the reinforcement member 6 due its physical properties, biocompatibility, and because it is less likely to bond with the inner layer 7 during vulcanization.

[0037] FIG. 6 depicts a family transfer mold 101 with cavity plates 102 and 103 in the closed mode. A sprue 104 is depicted in the center of the cavity plate 102. The family transfer mold 101 depicted in FIG. 6 is for molding a short length of molded spiral reinforced tubing 1 for developing test samples and prototypes. It will be appreciated that the cavity plates 102 and 103 can be sized to mold tubing 1 having a desired length. A rotary cavity shut off valve 123 in the cavity plate 102 allows for molding either the inner or outer layers separately or simultaneously. In actual implementa-

tion, production molds would likely be multi-cavity versions of either the inner layer 7 or the outer layer 8, since the inner layer 7 and the outer layer 8 may be molded from different elastomers or require different molding parameters such as transfer pressure, transfer speed, mold temperature and vulcanization or curing cycle times.

[0038] FIG. 7 depicts an isometric view of an opened family transfer mold 101 with the cavity plates 102 and 103 separated along their longitudinal axis for molding the inner layer 7 and the outer tubing layer 8. The cavity plate 102 includes a sprue 104 and a runner 105 for transferring elastomer to ring gate halves 106 and 108 in the cavity plate 102 and the opposing ring gate halves 107 and 109 located in the cavity plate 103. Ring gating from a single end of the tubing to introduce elastomer into the mold cavities substantially eliminates the potential for knit lines. Ring gating from a single end also minimizes the potential for bending of the mold core 110 that forms the lumen 2. FIG. 7 also depicts an inner layer cavity half 115 and an outer layer cavity half 117 in the cavity plate 103 and an inner layer cavity half 116 and an outer cavity half 118 in the cavity plate 102.

[0039] FIGS. 7a and 7b are enlarged plan views of the circled portions on the cavity plate 103 and the cavity plate 102, respectively, in FIG. 7. FIG. 7a is a plan view of the reinforcement securement surround half 119 located between the ring gate half 109 and the outer layer cavity half 117 in the cavity plate 103. FIG. 7b is a plan view of the reinforcement securement surround half 120 located between the ring gate half 108 and the outer layer cavity half 118 in the cavity plate 102. A reinforcement securement surround half 121 adjacent the outer layer cavity half 117 in cavity plate 103 and a reinforcement securement surround half 122 adjacent the outer layer cavity half 118 in cavity plate 102 are shown in FIG. 7. The reinforcement securement surrounds provide a segment to accommodate the bulk of the reinforcement securement means described above. FIG. 7 also shows a molded shot between separated cavity plates 102 and 103. The molded shot includes the inner layer 7 over the core 110, the outer tubing layer 8 over the inner tubing layer 7 and the reinforcement member 6, and a runner 18 connecting the cores 110.

[0040] The mold cavity plates 102 and 103 may be filled with a thermoset elastomer material using any suitable molding technique, such as compression, transfer, or LIM molding. With compression molding, the elastomer is placed in the mold cavities 115-118 and the elastomer is compressed as the mold is closed to fill out the part, replicating the mold detail. With transfer molding, the elastomer is placed in a transfer pot, usually a component of the press or mold. Transfer molding is accomplished by either closing the mold, if using a compression molding press, or closing the mold and activating the transfer plunger if using a transfer press. In either case, the elastomer is transferred through the sprue 104 in the mold and subsequently through the ring gate 106-109 to fill the mold forming the part. The runner 105 may be used to connect the sprue 104 and the gate 106-109. With LIM molding, multiple components of liquid elastomer are pumped separately to a mixing chamber from which they are fed into an injection chamber. The injection molding press closes the mold cavity plates 102 and 103 and subsequently injects the combined multi-component elastomer into the mold cavities 115-118, filling out the part. For thermoset elastomers, the parts may be compression, transfer or injection molded by introducing uncured elastomer into the mold cavities 115-



**118**, thermally curing the elastomer for a specific time, opening the mold, and removing the part along with the sprue **104** and runner **105**. For any thermoplastic elastomer, the parts may be injection molded by introducing molten elastomer into the mold cavities **115-118**, thermally cooling the elastomer for a specific time, opening the mold, and removing the part along with the sprue **104** and runner **105**.

[0041] FIG. **8** is a cross-sectional view of a single molded shot including the molded inner layer **7** on the core **110**, the outer layer **8** molded over the inner layer **7** and the reinforcement member **6**, and the runner **18** connecting cores **110**. FIG. **8a** is an enlarged cross-sectional view of the portion circled of the inner layer **7** on the core **110** in FIG. **8** depicting the ring gate **19**. FIG. **8b** is an enlarged cross-sectional view of the portion circled of the outer layer **8** on the core **110** in FIG. **8**, depicting the ring gate **20** and the reinforcement securement surround **21**.

[0042] While the present invention has been described with regard to a reinforced tubing **1** including a single spiral reinforcement member **6**, it will be appreciated that variations on this design are contemplated. For example, in an alternative embodiment, the tubing **1** may be configured to accommodate a plurality of continuous spiral reinforcement members **6**. Multiple spiral reinforcement members **6** may have advantages in certain applications and may be accomplished by providing detail for multiple reinforcement pathways **10** in the inner layer cavity halves **115** and **116**, additional crossholes in the core **110**, multiple recessed pathways **10** in the inner layer **7** and multiple reinforcement members **6** in the molded spiral reinforced tubing **1**. Multiple reinforcement members **6** may be used, for example, to reduce the reinforcement angle with respect to the longitudinal axis of the tubing **1**. Multiple reinforcement members **6** provide a larger reinforcement angle with respect to the tubing axis and will facilitate greater radial expansion of the lumen **2** for applications involving insertion of a connector or tubing insert.

[0043] In alternative embodiments, the reinforced tubing **1** is assembled with elements that provide additional functional components in the tubing **1**. For example, in embodiments including multiple recessed pathways **10**, a color coding member may be formed in one of the recessed pathways **10** to color code the tubing **1** for identification for particular applications. As another example, one or more of the multiple recessed pathways **10** may have one or more electrically conductive paths formed therein to communicate electrical signals between components connected by the tubing **1**. One or more of the multiple recessed pathways **10** may also include a fiber optic element to facilitate optical communication across the tubing **1**. Furthermore, one or more of the multiple recessed pathways **10** may have a sensing element formed therein to sense physiological characteristics (e.g., oxygen or pH levels) around the tubing **1**.

[0044] FIG. **9** depicts inner layer **7** on the core **110** with multiple centering projections **125** emanating from the outer surface **14** of the inner layer **7**, according to an alternative embodiment of the present invention. FIG. **9a** is an enlarged view of a cross-section of the inner layer **7** and the core **110** shown in FIG. **9** depicting multiple centering projections **125** emanating from the major diameter **14** of the inner layer **7**. The embodiment shown in FIGS. **9** and **9a** is configured to center the inner layer **7** with respect to the outer layer mold cavities **117** and **118** during molding of the outer layer **8**. In particular, the centering projections **125** are configured to contact the outer layer mold cavity halves **117** and **118**, during

molding of the outer molded layer **8**, to facilitate centering of inner molded tubing layer **7** within outer molded tubing layer **8**. In some embodiments, the centering projections **125** are positioned at a minimum of 120° apart radially, and a suitable distance apart axially, to maintain centering with respect to the mold cavity halves **117** and **118**.

[0045] The centering projections **125** is just one example mechanism that may be used to center the inner layer **7** with respect to the outer layer mold cavities **117** and **118** during overmolding. For example, FIG. **10** depicts the inner layer **7** and the reinforcement member **6** on the core **110** and a centering sleeve **124** positioned over the outer surface **14** of the inner layer **7** and the reinforcement member **6**, according to another embodiment of the present invention. The centering sleeve **124** is disposed around the outer surface **14** of the inner layer **7** and centers the inner layer **7** and the reinforcement member **6** within outer molded tubing layer **8**, during molding of the outer layer **8**. In some embodiments, the diameter of the bore of centering sleeve **124** is sized 0.001 to 0.002 inch greater than the diameter of the outer surface **14** of the inner layer **7** and the outer radius of the centering sleeve **124** is sized 0.001 to 0.002 inch smaller than the radii of the outer layer cavity halves **117** and **118**. The centering sleeve **124** is placed over the inner layer **7** and the reinforcement member **6** and axially located proximal to outer layer ring gate halves **108** and **109**. As elastomer is introduced into the mold, it advances the centering sleeve **124** axially between inner molded tubing layer **7** and cavity halves **117** and **118** until the elastomer flow is complete and the centering sleeve **124** is distal to the ring gate **108**, **109**. The centering sleeve **124** can be fabricated from a heat resistant plastic such as polysulfone or metal such as aluminum or stainless steel. FIG. **11** depicts molded spiral reinforced tubing with the outer layer **8** and the centering sleeve **124** on the mold core **110** after molding the outer layer **8**.

[0046] FIG. **12** is an isometric view of a family transfer mold for molding the inner layer **7** and the outer layer **8**, prior to molding the device shown in FIGS. **10** and **11**. The cavity plates **102** and **103** are separated along their longitudinal axis. The centering sleeve **124** is located proximal to the ring gate half **108** of the cavity plate **102** and the ring gate half **109** of the cavity plate **103** prior to molding. The centering sleeve **124** is radially positioned over the inner layer **7** and the reinforcement member **6** on the core **110**. FIG. **13** is an isometric view of a family transfer mold after molding the inner layer **7** on the core **110** and the outer layer **8** over the inner layer **7** and the reinforcement member **6**. As is shown, the centering sleeve **124** travels to the end distal to the ring gate **108**, **109** during molding of the outer layer **8**.

[0047] Molded tubing provides design opportunity because the bore and major diameter need not have a continuous profile. Molding multiple layer tubing provides additional design freedom especially when reinforcement is incorporated in the tubing. For example, the tubing **1** of the present invention has a non-continuous outer surface **14** on the inner layer **7** that includes a recessed pathway **10** for accommodating a spiral reinforcement member **6**. The recessed pathway **10** eliminates the need to tension the reinforcement member **6** to stabilize it during subsequent manufacturing operations, which also provides design opportunity to fabricate tubing **1** with a continuous lumen **2**. A reinforcement member **6** that is not tensioned is less likely to cause localized stress that could initiate fatigue failure than a tensioned reinforcement. In addition, the greatest elongation during bending or flexing of

the inner layer of the tubing **1** is directed to the thinnest cross-section at the bottom of the recessed pathway **10**. The compressive and tensile stresses from flex of the tubing **1** are minimized by reducing the thickness. Spiral reinforcement member **6** causes the greatest abrasive activity at the base of the recessed pathway during flex of the tubing **1**. However, the reduction or elimination of tension on the reinforcement member **6** as is done in the tubing **1** according to the present invention can significantly reduce this abrasive activity. That is, the tubing **1** is provided with the recessed pathway **10** on the inner layer **7**, facilitating spiral reinforcement with minimal or no tension, so that compressive forces caused by the reinforcement member **6** on the adjacent inner layer **7** during flex of tubing **1** are reduced for greater fatigue resistance.

**[0048]** One or more of the following advantages may be provided in certain implementations. First, molded spiral reinforced tubing can be provided that is simple to manufacture. Second, molded spiral reinforced tubing can be provided that can be manufactured more consistently than extruded spiral reinforced tubing. Third, molded tubing provides greater design freedom over extruded tubing because the tubing profile need not be continuous and enables incorporation of features for ease of manufacture or improved performance. Fourth, molded spiral reinforced tubing can be provided with a constant lumen without undulations from tensioned reinforcement. Fifth, molded spiral reinforced tubing can be provided with greater fatigue resistance than extruded spiral reinforced tubing.

**[0049]** A significant advantage in molded silicone tubing over extruded silicone tubing is that molded tubing is compressed and densified during vulcanization or curing. Extruding tubing is compressed as it is forced through an extrusion die but is not densified during vulcanization. Physical properties are enhanced as the interface between the elastomer and reinforcing filler improves and mechanical densification that occurs during closed molding improves that interface.

**[0050]** Various modifications and additions can be made to the exemplary embodiments discussed without departing from the scope of the present invention. For example, while the embodiments described above refer to particular features, the scope of this invention also includes embodiments having different combinations of features and embodiments that do not include all of the described features. Accordingly, the scope of the present invention is intended to embrace all such alternatives, modifications, and variations as fall within the scope of the claims, together with all equivalents thereof.

What is claimed is:

**1.** A tubing for connecting components in medical devices, the tubing comprising:

a molded inner layer comprised of an elastomeric material, wherein the inner layer includes an inner surface having an inner diameter that defines a lumen and further includes an outer surface having an outer diameter, and wherein the outer surface includes one or more recessed pathways formed therein;

a continuous reinforcement element within at least one of the one or more recessed pathways; and

a molded outer layer comprised of an elastomeric material, wherein the outer layer includes an inner surface having an inner diameter and an outer surface having an outer diameter, and wherein the inner surface of the outer layer substantially conforms with the reinforcement element

and the outer surface of the inner layer and is secured to the outer surface of the inner layer.

**2.** The tubing of claim **1**, wherein the outer layer is chemically and/or mechanically secured to the inner layer.

**3.** The tubing of claim **1**, wherein the outer layer is not chemically or mechanically secured to the reinforcement element.

**4.** The tubing of claim **1**, wherein the reinforcement element comprises a coating to reduce surface tension between the reinforcement element and the inner and outer layers.

**5.** The tubing of claim **1**, wherein at least one of the inner layer and the outer layer comprises a thermoplastic elastomer.

**6.** The tubing of claim **5**, wherein the thermoplastic elastomer comprises a material selected from the group consisting of polyvinyl chloride (PVC) and polyurethane.

**7.** The tubing of claim **1**, wherein at least one of the inner layer and the outer layer comprises a thermoset elastomer.

**8.** The tubing of claim **7**, wherein the thermoset elastomer comprises a material selected from the group consisting of ethylene propylene diene monomer (EPDM) and silicone.

**9.** The tubing of claim **8**, wherein the outer layer is coated with an acetoxy cured silicone to enhance abrasion resistance.

**10.** A tubing of claim **9**, wherein the acetoxy cured silicone is applied as a dispersion.

**11.** The tubing of claim **1**, wherein each recessed pathway includes an arc having a radius at its base.

**12.** The tubing of claim **11**, wherein the radius of the arc is between about 2% and about 40% smaller than a radius of the reinforcement element.

**13.** The tubing of claim **12**, wherein the radius of the arc is between about 10% and about 20% smaller than a radius of the reinforcement element.

**14.** The tubing of claim **1**, wherein each recessed pathway includes transition arcs between the outer surface of the inner layer and the recessed pathway.

**15.** The tubing of claim **1**, wherein a depth of the one or more recessed pathway is substantially equal to a diameter of the reinforcement element.

**16.** The tubing of claim **1**, wherein the reinforcement element is comprised of a metallic material.

**17.** The tubing of claim **16**, wherein the metallic material is selected from the group consisting of carbon steel, non-carbon steel, stainless steel, and MP35N.

**18.** The tubing of claim **1**, wherein the reinforcement element is comprised of a polymeric material.

**19.** The tubing of claim **18**, wherein the polymeric material is selected from the group consisting of polypropylene and polyamide.

**20.** The tubing of claim **1**, wherein the outer surface of the inner layer includes a plurality of projections configured to contact an outer layer mold during molding of the outer layer to facilitate centering of the inner layer with respect to the outer layer.

**21.** The tubing of claim **1**, and further comprising at least one of a sensor, a fiber optic cable, and an electrical conductor within at least one of the one or more recessed pathways.

**22.** The tubing of claim **1**, wherein the medical device is selected from the group consisting of an inflatable penile prosthesis, an inflatable urinary incontinence device, and inflatable fecal incontinence device, an inflatable mammary prosthesis, an inflatable tissue expander, and a medical device with a remote injection port.