



(19) **United States**

(12) **Patent Application Publication**
Coleman et al.

(10) **Pub. No.: US 2009/0217574 A1**

(43) **Pub. Date: Sep. 3, 2009**

(54) **PROCESS, SYSTEM AND APPARATUS FOR PASSIVATING CARBONACEOUS MATERIALS**

(76) Inventors: **James Coleman, Perth (AU); David Cork, Mayfield (AU)**

Correspondence Address:
LADAS & PARRY LLP
224 SOUTH MICHIGAN AVENUE, SUITE 1600
CHICAGO, IL 60604 (US)

(21) Appl. No.: **12/091,503**

(22) PCT Filed: **Oct. 26, 2006**

(86) PCT No.: **PCT/AU2006/001604**

§ 371 (c)(1),
(2), (4) Date: **Sep. 16, 2008**

(30) **Foreign Application Priority Data**

Oct. 26, 2005 (AU) 2005905934
Dec. 5, 2005 (AU) 2005906808

Publication Classification

(51) **Int. Cl.**
C10L 9/02 (2006.01)
C10L 5/00 (2006.01)
C10L 9/08 (2006.01)
C10L 9/10 (2006.01)
(52) **U.S. Cl.** **44/501; 202/99; 202/100; 201/9; 422/233**

(57) **ABSTRACT**

A process, system and apparatus is provided for passivating carbonaceous material against spontaneous combustion. The process involves drying the carbonaceous material in a low oxygen environment and pre-conditioning the carbonaceous material by contacting it with volatile matter contained in a countercurrent gas stream. The volatile matter coats the particles of dried carbonaceous material and plugs the micropores of the dried carbonaceous material, thereby passivating it against adsorption of water and oxygen, and thus spontaneous combustion. The pre-conditioned dried material then undergoes devolatilisation at temperatures at which volatile matter is evolved. The evolved volatile matter mixes with the countercurrent gas stream and is used to pre-condition dried carbonaceous material located upstream.

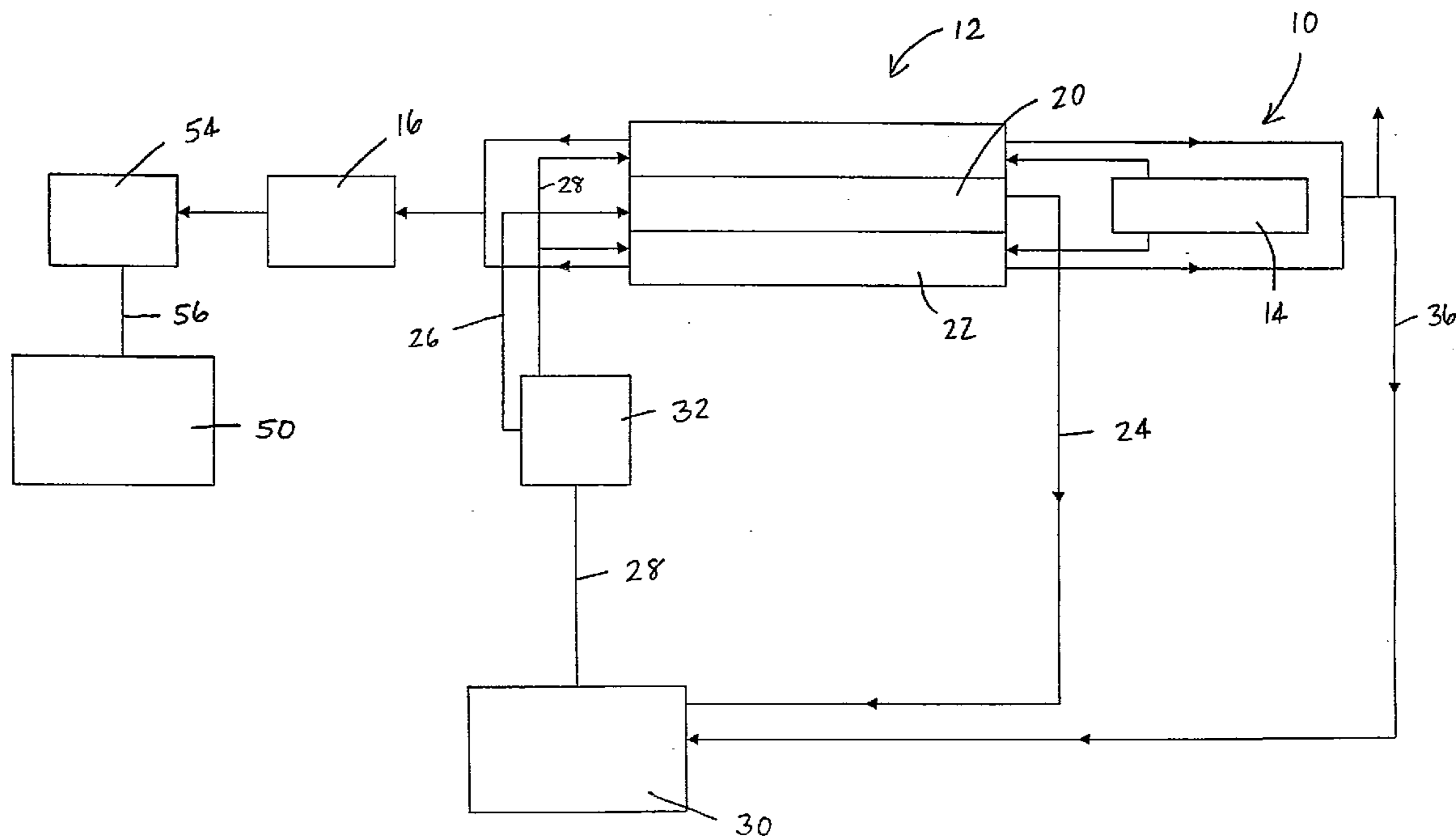

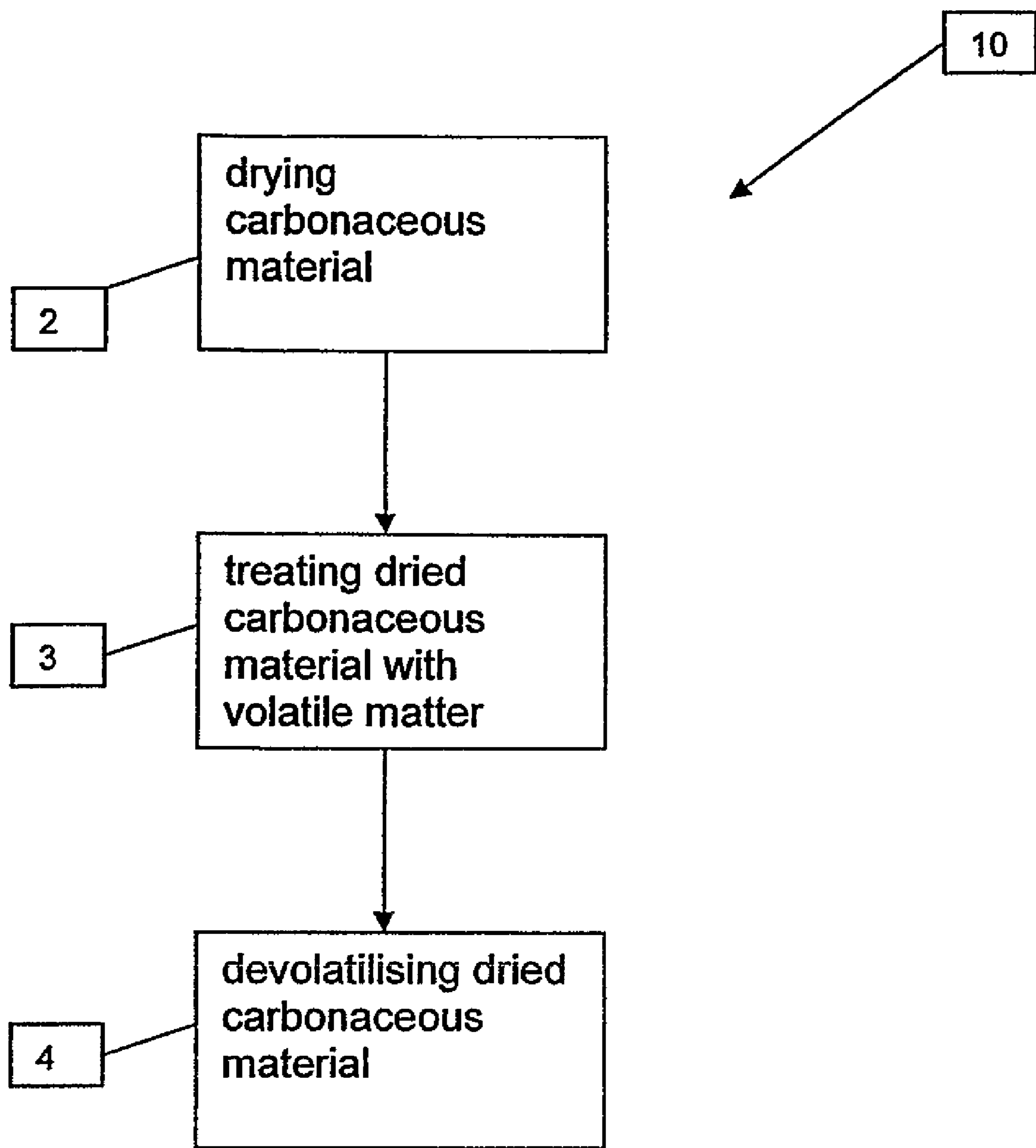

Figure 1

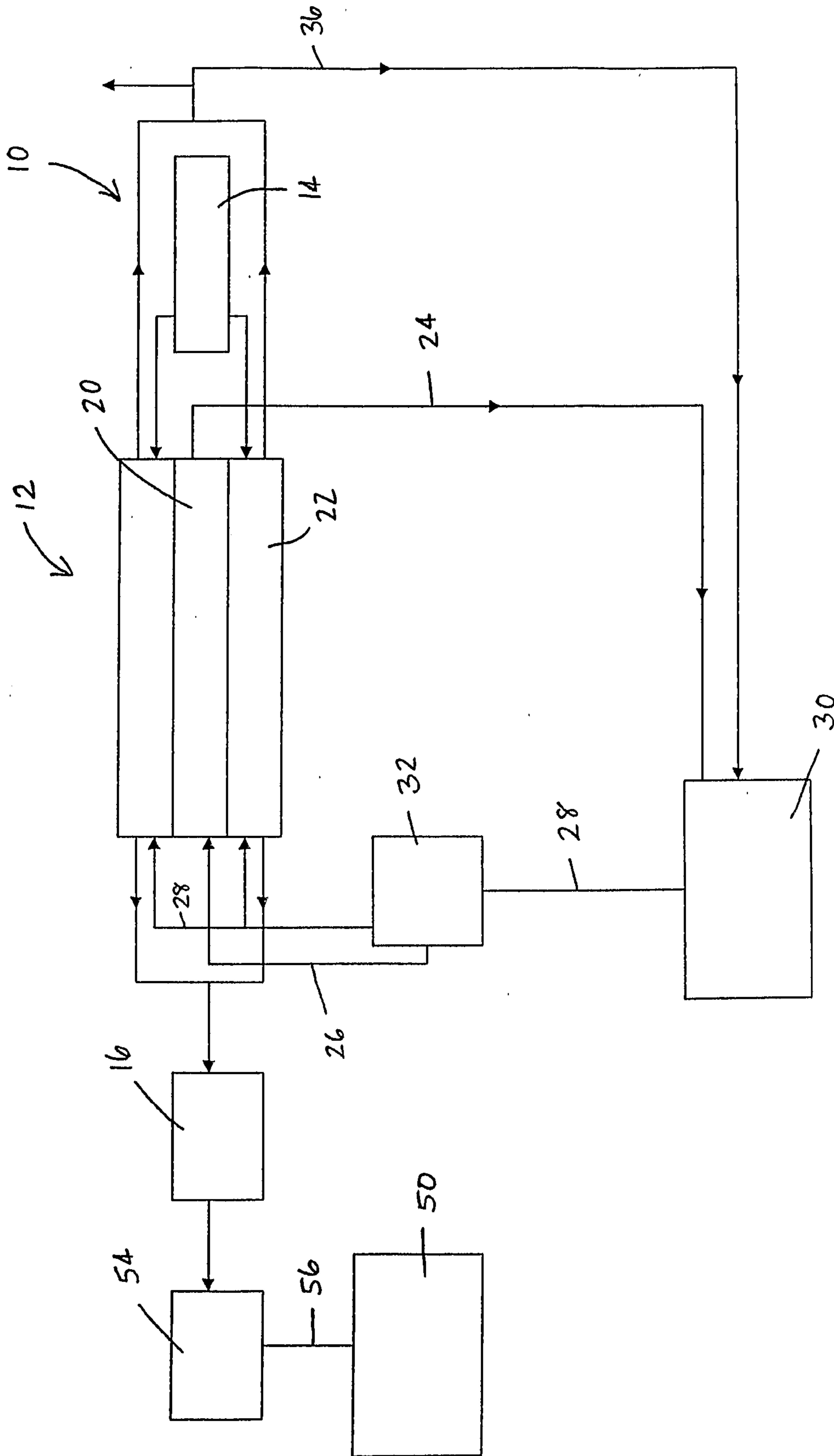

FIGURE 2

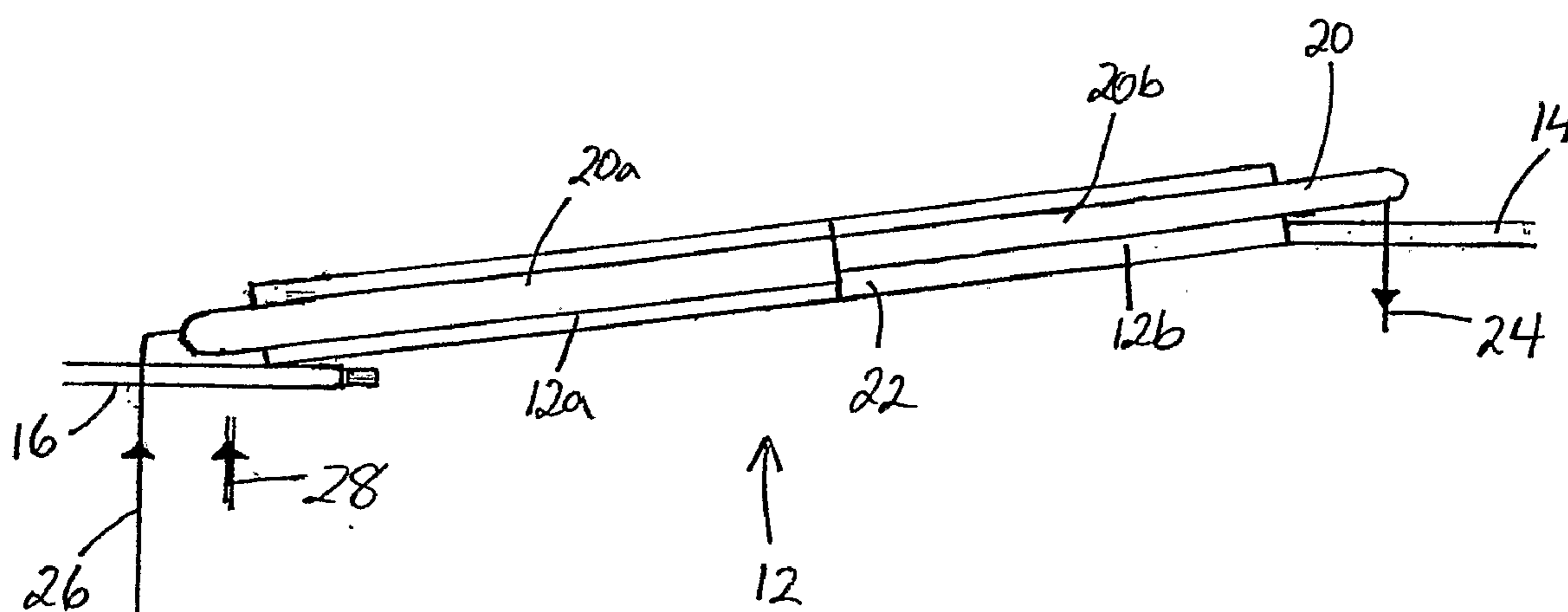

Figure 3

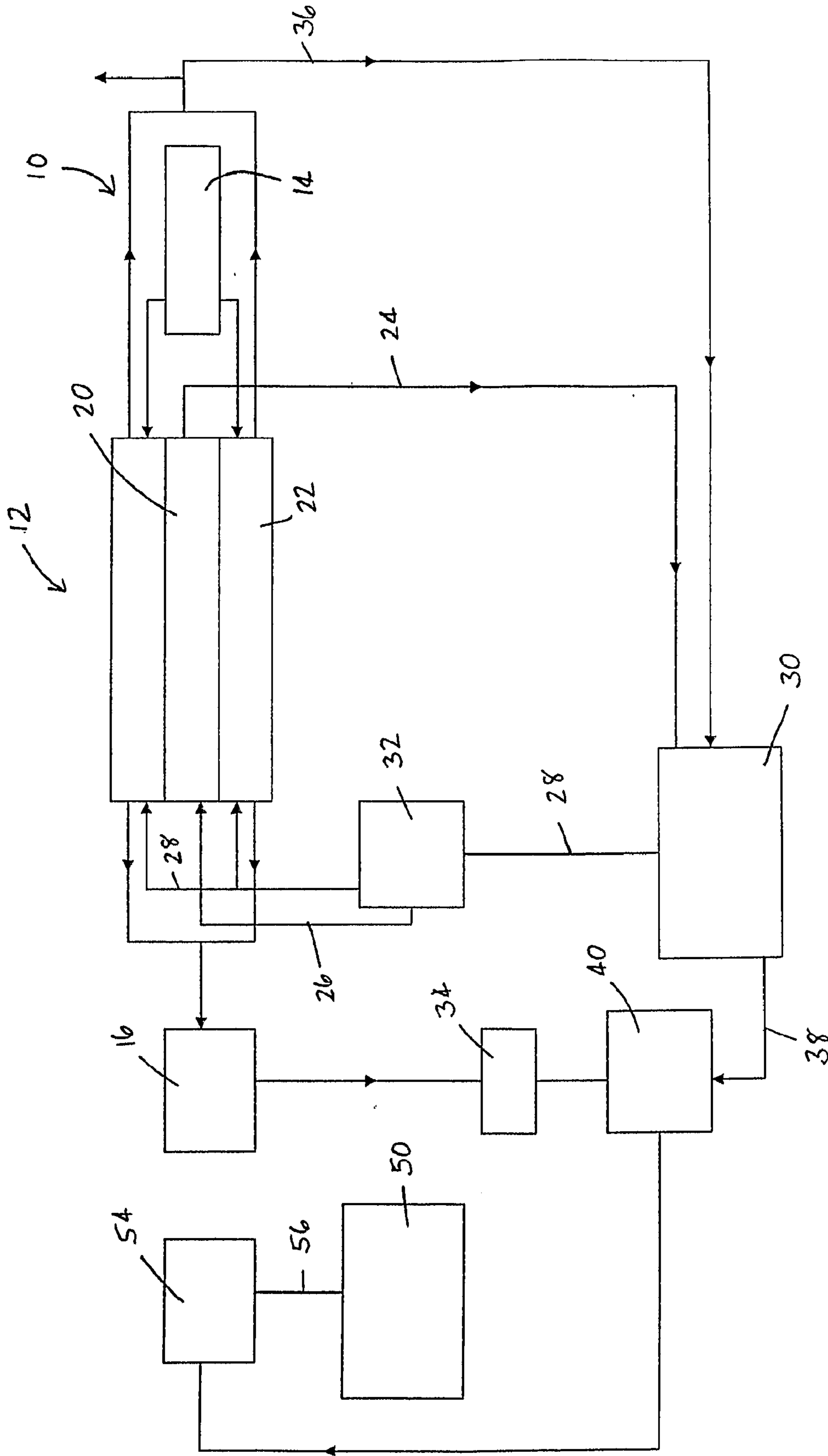

FIGURE 4

**PROCESS, SYSTEM AND APPARATUS FOR
PASSIVATING CARBONACEOUS
MATERIALS**

FIELD OF THE INVENTION

[0001] The present invention relates to a process, system and apparatus for passivating carbonaceous materials against spontaneous combustion. An apparatus for heating oxygen sensitive carbonaceous material in a controlled oxygen environment is also described.

BACKGROUND OF THE INVENTION

[0002] Coal pyrolysis occurs upon heating coal to produce gases, liquids, and a solid residue (char or coke). Pyrolysis occurs in all coal utilisation processes, including combustion, gasification, liquefaction, and carbonisation. The nature of pyrolysis and of the resulting products is intimately related to the operating conditions and to the composition and properties of the coal. Consequently, control of pyrolysis is important in coal utilisation processes.

[0003] The principal difference between char and coke is that the parent coal for char has high oxygen content and a non-aromatic structure and therefore the char particles do not tend to agglomerate during pyrolysis. The parent coal for coke has much lower oxygen content and an aromatic structure. Coke feed stock undergoes a plastic phase and agglomerates during pyrolysis. Feed stock that normally produces coke can be used to produce char by pyrolysis thereof in an atmosphere with a slight to moderate oxygen content.

[0004] Historically, on an industrial scale, char has been an undesirable by-product of a smokeless fuel plant, coke works or coal gasification plant, although smaller scale plants produce char for activated carbon and micro blast furnaces. One of the least desirable characteristics of some dried chars is that they can be pyrophoric when exposed to an oxygen-containing atmosphere.

[0005] This tendency to spontaneously combust is promoted by rapid adsorption of water vapour and oxygen by dried char. Oxygen physically adsorbs onto the surface of the dried char and chemically reacts in an exothermic oxidation reaction with the organic molecules within the char. The heat release, if not dissipated, will promote a self-accelerating oxidation process, causing the temperature of the char to rise progressively until the char spontaneously ignites. The rise in temperature of the char is also promoted by latent heat of vaporization released by adsorption of water onto the char particles.

[0006] Other dried carbonaceous material, in particular dried low rank coal is also susceptible to spontaneous combustion for similar reasons as outlined above. Thus the storage of stock piles of carbonaceous material is closely dependent on control of the moisture content within the stock pile, and it is desirable that the carbonaceous material is suitably treated to passivate it against water adsorption and oxidation.

[0007] One approach to reduce the potential for spontaneous combustion of dried char is to seal the exterior surface of the char by using oils, polymers, waxes or other materials to coat the surface thereof. Examples of such coating processes are U.S. Pat. Nos. 3,985,516 and 3,985,517, which disclose heating and intimate mixing of coal with heavy oils to coat the particles. Such coating procedures are effective in preventing

reabsorption of moisture by the char, however, such coatings are expensive due to the cost of the hydrocarbon materials added.

[0008] Another approach is to subsequently treat the dried coal or char particles with oxygen under controlled conditions to oxidatively passivate the char. U.S. Pat. No. 5,601,692 describes a continuous process for treating a non-caking coal to form stable char. The process involves several sequential steps including drying the coal to remove moisture therefrom and pyrolysing the dried coal to vaporise and remove low end volatile materials from the coal to form char and to mobilize at least a portion of high end volatile materials within the char and at least partially collapse micropores within the char. The char is then cooled to a temperature sufficient to demobilize the volatile materials within the partially collapsed micropores of the char to pyrolytically passivate the char, and is subsequently treated with an oxygen containing gas to oxidatively passivate the coal by chemisorption of oxygen. The oxidatively passivated char is then simultaneously rehydrated and cooled.

[0009] It would be advantageous to dry coals and process them in such a manner that the dried coal or char particles are passivated against spontaneous combustion without the need for externally supplied coating materials or subsequent multi-step treatment processes.

[0010] The present invention seeks to overcome at least some of the aforementioned disadvantages. Advantageously, the invention increases the specific energy of the treated carbonaceous material making it a more commercially attractive product, particularly for shipping. Additionally, the organic sulfur content thereof is also reduced.

[0011] It is to be understood that, although prior art use and publications may be referred to herein, such reference does not constitute an admission that any of these form a part of the common general knowledge in the art, in Australia or any other country.

SUMMARY OF THE INVENTION

[0012] It has been demonstrated that a carbonaceous material feed stream may be dried and carbonised to produce char, both processes being conducted simultaneously in a single vessel or, alternatively, the drying and carbonisation processes may be conducted sequentially in two separate vessels. The volatile matter evolved from the carbonaceous material feed stream during carbonisation, often referred to as coal gas, generally has a high calorific content and contains tars. Previously, attention has been directed to separating the coal gas from the char and improving the high calorific content of the coal gas generated during carbonisation so that its commercial potential can be fully exploited.

[0013] The present invention is based on the realisation that it is possible to passivate carbonaceous material by treating the dried carbonaceous material with the volatile matter evolved during low temperature and/or medium temperature devolatilisation of the carbonaceous material.

[0014] Accordingly, in one aspect of the invention there is provided a process for preparing a passivated carbonaceous material comprising the steps of:

- [0015]** a) drying a carbonaceous material feed stream;
- [0016]** b) treating the dried carbonaceous material with volatile matter; and
- [0017]** c) devolatilising the dried carbonaceous material feed stream and forming the passivated carbonaceous material and volatile matter.

[0018] In one embodiment of the invention, the step of treating the dried carbonaceous material feed stream comprises contacting the dried carbonaceous material feed stream with a gas stream containing volatile matter.

[0019] While not wishing to be bound by theory, the inventors opine that tars and other organic compounds contained in the volatile matter coat particles of the carbonaceous material, plugging the micropores of the particles and thereby reducing the adsorption of water and oxygen. Upon further heating of the carbonaceous material during step c), the tars and organic compounds undergo pyrolysis. Pyrolytic rupture of functional groups attached to aromatic and hydroaromatic moieties on the carbonaceous material leads to release of low molecular weight reactive free radical fragments and stabilization of the former fragment sites by hydrogen. They hydrophilic polar functional groups are thereby converted to, and replaced by, an hydrophobic aromatic coating, thus passivating the dried carbonaceous material against spontaneous combustion.

[0020] In one embodiment, the gas stream containing volatile matter is directed in a counter current flow relative to the dried carbonaceous material.

[0021] In one embodiment of the invention, the volatile matter contained in the gas stream comprises volatile matter evolved during step c). In another embodiment, the volatile matter evolved during devolatilisation of the dried carbonaceous material is augmented by doping the carbonaceous material feed stream with materials containing large amounts of hydrophobic aromatic moieties that would enrich the volatile matter with these species during devolatilisation. Suitable examples of such materials containing large amounts of hydrophobic aromatic moieties will be well known to those skilled in the art and include, but are not limited to, waste rubber, in particular vehicle tyres, and plastics materials.

[0022] In an alternative embodiment, the volatile matter contained in the gas stream comprises volatile matter evolved from devolatilisation of a volatile matter feedstock distinct and separate from the carbonaceous material feed stream of the present process. Typically, the volatile matter feedstock comprises materials containing large amounts of hydrophobic aromatic moieties as described above.

[0023] While the temperature of the onset of thermal decomposition proper is generally recognized to be approximately 350° C., low molecular weight species will evolve at temperatures less than 350° C. during low temperature devolatilisation. For example at temperatures just in excess of 100° C., a coal such as lignite, which contains many carboxylic functions as part of the coal structure, will evolve carbon dioxide by thermal decarboxylation. As the temperature of the thermal treatment is increased to the range 200-370° C., coals lose a variety of lower molecular weight organic species, especially aliphatic compounds, and some of the lower molecular weight aromatic species can also be obtained. At higher temperatures e.g. >370° C., methane, polycyclic aromatics, phenols, and nitrogen compounds are produced. Thus, volatile matter including, but not limited to, acidic species, hydrophobic species such as low molecular weight aromatic species, polycyclic aromatics and phenols, evolves during step a) of the present invention.

[0024] Accordingly, in another embodiment of the invention, the volatile matter contained in the gas stream comprises volatile matter evolved during step a).

[0025] In one embodiment, the step of drying the carbonaceous material feed stream comprises heating the carbon-

aceous material feed stream from about 100° C. to 400° C. Typically, the drying step is conducted under a low oxygen (0-5% O₂ v/v) and high moisture (up to 50% v/v) atmosphere.

[0026] The carbonaceous material feed stream may be heated directly or indirectly to the temperatures at which the drying step is performed.

[0027] The terms “direct heating” or “heated directly” as used herein refer to a manner of heating the carbonaceous material feed stream wherein a hot gas stream, from a local or a remote source, at a pre-determined temperature is arranged to come into contact with the particles of carbonaceous material of the carbonaceous material feed stream to facilitate a gas-solid heat exchange.

[0028] The terms “indirect heating” or “heated indirectly” as used herein encompass a manner of heating the carbonaceous material feed stream wherein a gas stream from a local or a remote source, at a pre-determined temperature is prevented from coming into contact with the particles of the carbonaceous material feed stream, but is used instead to heat the vessel containing the carbonaceous material feed stream.

[0029] Additionally, the terms “indirect heating” or “heated indirectly” also encompass any manner of heating the vessel containing the carbonaceous material feed stream so as to heat the carbonaceous material feed stream to a desired temperature, as would be understood and known to a person skilled in the art.

[0030] In one embodiment, the carbonaceous material feed stream is directly heated.

[0031] In one embodiment of the invention, the carbonaceous material feed stream is directly heated by contacting the carbonaceous material feed stream with a hot gas stream having a low oxygen content. Typically, the oxygen content of the hot gas stream is less than 5% v/v, and preferably less than 1% v/v.

[0032] In one embodiment, the hot gas stream is contacted with the carbonaceous material feed stream in a countercurrent direction relative to the carbonaceous material feed stream.

[0033] As described previously, volatile matter can evolve at the temperatures at which the carbonaceous material feed stream is dried. The volatile matter evolved during step a) mixes with the hot gas stream and is directed in a countercurrent flow relative to the carbonaceous material feed stream, and subsequently contacts the dried carbonaceous material thereby treating the dried carbonaceous material. Thus, in one embodiment of the invention, step a) and step b) are performed at substantially the same time.

[0034] In another embodiment, the step of contacting the dried carbonaceous material with a gas stream containing volatile matter is facilitated by directing a countercurrent flow of the hot gas stream relative to the dried carbonaceous material, wherein the hot gas stream is used to heat the carbonaceous material feed stream to temperatures at which step a) is performed.

[0035] In return, the countercurrent flow of dried particles cools and scrubs the hot gas stream, thereby improving the thermal efficiency of the process.

[0036] In one embodiment of the invention, the step of devolatilising the dried carbonaceous material comprises heating the dried carbonaceous material from about 400° C. to 900° C., preferably 600° C. to 800° C. Typically, the devolatilising step is conducted under a low oxygen (0-5% O₂ v/v) atmosphere.

[0037] In one embodiment, the dried carbonaceous material is directly heated. Typically, the dried carbonaceous material is directly heated by contacting the dried carbonaceous material with a hot gas stream having a low oxygen content. The oxygen content of the hot gas stream is less than 5% v/v, and preferably less than 1% v/v.

[0038] In one embodiment, the hot gas stream is contacted with the dried carbonaceous material in a countercurrent direction relative to the dried carbonaceous material.

[0039] Volatile matter evolves at the temperatures at which the dried carbonaceous material undergoes devolatilisation in step c). In accordance with one embodiment of the invention the same hot gas stream is used in step c) and then subsequently in step a). The volatile matter mixes with the hot gas stream and is directed in a countercurrent flow relative to the dried carbonaceous material, and subsequently contacts the dried carbonaceous material located upstream, thereby pre-conditioning the dried carbonaceous material before it is devolatilised.

[0040] Typically, the passivated carbonaceous material feed stream produced by the process of the present invention has its moisture content reduced to between 0-20% moisture and its volatile matter content reduced to 0-25% in comparison with the moisture and volatile matter content of the carbonaceous material feed stream.

[0041] The process further comprises the step of quenching the passivated carbonaceous material. In one embodiment, the passivated carbonaceous material is quenched with water and/or cool inert gas. The quenched passivated carbonaceous material can then be cooled to ambient temperature, stock-piled and loaded out. In an alternative embodiment, the passivated carbonaceous material is quenched with untreated carbonaceous material, including but not limited to wet screened coal.

[0042] In a second aspect of the present invention there is provided a system for preparing passivated carbonaceous materials comprising:

[0043] a dryer for drying a carbonaceous material feed stream;

[0044] a pyrolyser for devolatilising dried carbonaceous material and forming passivated carbonaceous material and volatile matter; and

[0045] a carrier vehicle for facilitating contact of volatile matter with the dried carbonaceous material.

[0046] Suitable examples of a dryer include, but are not limited to, a rotary kiln, a multiple hearth furnace (MHF), flash dryer, or a circulating fluid bed (CFB). In one embodiment, the dryer comprises a rotary kiln. In an alternative embodiment, the dryer comprises a circulating fluidized bed, preferably a differentially circulating fluidized bed.

[0047] Typically, the rotary kiln is configured at an angle of up to 10°, preferably 2-5°, above the horizontal to facilitate passage of the carbonaceous material feed stream through the rotary kiln under gravity. The rotary kiln is provided with a means to rotate the rotary kiln about its central longitudinal axis, and the rotational speed thereof is typically selected to correspond with the length of the rotary kiln such that a residence time of the carbonaceous material feed stream in the rotary kiln is about 15-40 minutes.

[0048] In one embodiment of the present invention the dryer is arranged to heat the carbonaceous material feed stream to 100° C. to 400° C. Typically, the dryer is heated by a hot gas stream (400° C. to 800° C.) having a low oxygen content. The oxygen content of the hot stream of gas is less

than 5% v/v and preferably less than 1% v/v. Oxygen is preferably substantially excluded from the carbonaceous material feed stream, or at least at a controlled low concentration, throughout its residence time within the dryer.

[0049] The pyrolyser for devolatilising the dried carbonaceous material feed stream and forming the passivated carbonaceous material and volatile matter comprises any one or more in combination of a rotary kiln, multiple hearth furnace (MHF), or a circulating fluid bed (CFB). In the preferred embodiment, the pyrolyser comprises a multiple hearth furnace.

[0050] In one embodiment, the dried carbonaceous material feed stream in the multiple hearth furnace is directly heated with a hot gas stream having a low oxygen content to temperatures of about 600° C.-800° C.

[0051] The oxygen content of the hot gas stream is less than 5% v/v and preferably less than 1% v/v. Typically, the hot gas stream comprises combustion gas generated from an external burner. In one embodiment the system is further provided with an external burner to generate a hot gas stream used for directly heating the pyrolyser and heating the dryer of the system, respectively. In this way, the carbonaceous material feed stream may be heated in the dryer and/or the pyrolyser at a controlled temperature and oxygen concentration. Oxygenated hot gas is not unnecessarily mixed with the carbonaceous material feed stream unless combustion is required.

[0052] The hot gas stream is directed in counter current flow against the dried carbonaceous material in the pyrolyser. The hot gas stream combines with the volatile matter evolved in the pyrolyser and thus acts as a carrier vehicle for the volatile matter. In this way, the volatile matter is directed in counter current flow against the dried carbonaceous material in the pyrolyser to facilitate contact of the volatile matter with the dried carbonaceous material.

[0053] In another embodiment of the invention, the system further comprises a means for feeding the dried carbonaceous material from the dryer to the pyrolyser. Typically, the means for feeding the dried carbonaceous material to the pyrolyser comprises a closed pneumatic system.

[0054] In the description of the present invention it will be evident that the inherent moisture of the carbonaceous materials is reduced. Additionally, the specific energy of the carbonaceous materials is also increased by both the removal of oxygen and sulfur from the carbonaceous material during drying and carbonisation of the dried carbonaceous material. In this way, carbonaceous materials treated by the process of the present invention are able to be transported more economically over long distances.

[0055] Thus, in a further aspect of the present invention there is provided a process for reducing inherent moisture in and/or increasing a specific energy of a carbonaceous material comprising the steps of:

[0056] a) drying a carbonaceous material feed stream; and

[0057] b) carbonising the dried carbonaceous material by contacting the dried carbonaceous material with a counter current gas stream having a low oxygen content.

[0058] In one embodiment the oxygen content of the gas stream is less than 5%. Typically, the oxygen content of the gas stream is less than 1%. In some embodiments, the gas stream having the low oxygen content is produced by the combustion of a carbon source. Typical examples of such carbon sources include, but are not limited to, coal gas, pulverized coal, char or coke.

[0059] In one embodiment the gas stream having a low oxygen content is contacted with the dried carbonaceous material at a temperature of between 400° C. and 800° C.

[0060] In another embodiment, steps a) and b) are both carried out by contacting the carbonaceous material with the gas stream having a low oxygen content whereby said gas stream initially dries the carbonaceous material and then proceeds to carbonise the carbonaceous material.

[0061] In a further embodiment of the invention, the gas stream contains volatile matter. In one embodiment the volatile matter evolves during step b) and mixes with the gas stream. In another embodiment, the volatile matter evolves during step a) and mixes with the gas stream. The volatile matter coats the carbonaceous material and provides the aforementioned advantages.

[0062] One of the most surprising benefits of the process of the present invention is that the character of some carbonaceous materials can be significantly changed. For example, low rank coals have a high inherent moisture content, comparatively low specific energy, and are unsuitable for production of metallurgical coke. The suitability of the present invention to reduce inherent moisture content and increase specific energy of a carbonaceous material has already been described. Additionally, however, the process of the present invention produces a carbonaceous material whose particles are coated with tarry gases, aromatic and other hydrophobic moieties comprised in the volatile matter. These species improve the plasticity of the carbonaceous material during high temperature carbonization. In this way, low rank coals treated in accordance with the process of the present invention are converted to a carbonaceous material which has improved characteristics for inclusion in a coking coal blend.

[0063] Thus, in a yet further aspect of the present invention there is provided a process for improving the coking characteristics of non-coking carbonaceous material comprising the steps of:

[0064] a) drying a non-coking carbonaceous material feed stream;

[0065] b) treating the dried non-coking carbonaceous material with volatile matter; and

[0066] c) devolatilising the treated dried non-coking carbonaceous material and forming a carbonaceous material with improved coking characteristics and volatile matter.

[0067] In prior art systems, hot char produced in a carbonising process is typically quenched with water and/or inert gases to lower the temperature of the particles to below 100° C. Carefully controlled conditions for the quenching process and subsequent storage of the quenched char are required because of the tendency of char to spontaneously combust under conditions where oxygen and/or water adsorption onto the char particles is allowed to occur, as described above.

[0068] The present invention is based on the realisation that passivated char does not tend to spontaneously combust when exposed to conditions under which water and/or oxygen adsorption occur, and thus it is possible to quench hot passivated char by contacting the hot passivated char with a particulate material under ambient conditions to facilitate solid-solid heat transfer. Precautions against exposing the char to conditions under which oxygen and/or water adsorption occur, to prevent spontaneous combustion of the char, are no longer required.

[0069] Thus, in, an alternative aspect of the present invention there is provided a process for quenching hot passivated char comprising contacting the hot passivated char with a particulate material.

[0070] In one embodiment of the invention the step of contacting the hot passivated char with the particulate material comprises mixing the hot passivated char with the particulate material and facilitating a solid-solid heat exchange between particles of the hot passivated char and the particulate material. Typically, the particulate material will be at ambient temperature. The hot passivated char and the particulate material blend can be further mixed with a cool inert gas stream to facilitate further quenching thereof.

[0071] In one embodiment of the invention the particulate material is a carbonaceous material, in particular wet screened coal. Advantageously, when the particulate material is wet screened coal, the temperature of the hot passivated char is lowered by direct heat transfer to the wet screened coal at ambient temperature. Additionally, thermal energy contained in the hot passivated char will also be employed in removing moisture from the wet screened coal. Preferably, the step of blending the carbonaceous material and passivated char is conducted in a substantially oxygen-free atmosphere.

[0072] In this way, it is possible to mix wet screened coal with hot passivated char to produce a blended carbonaceous material with desired particle size, fixed carbon content, volatile matter content, and moisture to meet specific market requirements, the preferred proportion of passivated char to carbonaceous material being dependent on the preferred parameter, such as for example volatile matter content of the blend.

[0073] According to another aspect the present invention provides an apparatus, for use in a continuous process, for passivating carbonaceous material, the apparatus comprising:

[0074] a) an inlet for receiving a feed stream of carbonaceous material;

[0075] b) an inlet for receiving a gas stream containing volatile matter;

[0076] c) a reaction portion configured to allow the carbonaceous material to come into contact with the gas stream containing volatile matter;

[0077] d) an outlet for receiving the passivated carbonaceous material after it has passed through the reaction portion; and

[0078] e) an outlet for receiving the gas after it has passed through the reaction portion.

[0079] Additionally, there is provided an apparatus for heating oxygen sensitive carbonaceous material in a controlled oxygen environment, the apparatus comprising:

[0080] a) an inlet for receiving a flow of carbonaceous material;

[0081] b) an inlet for receiving a flow of gas with a controlled oxygen content containing volatile matter;

[0082] c) a reaction portion, configured to allow the carbonaceous material to come into contact with the gas with a controlled oxygen content containing volatile matter;

[0083] d) an outlet for receiving the carbonaceous material after it has passed through the reaction portion; and,

[0084] e) an outlet for receiving the gas after it has passed through the reaction portion.

[0085] In the description of the invention and the claims, except where the context requires otherwise due to express language or necessary implication, the words “comprise” or

variations such as “comprises” or “comprising” are used in an inclusive sense, i.e. to specify the presence of the stated features, but not to preclude the presence or addition of further features in various embodiments of the invention.

BRIEF DESCRIPTION OF THE FIGURES

[0086] Preferred embodiments of the present invention will now be described, by way of example only, with reference to the accompanying figures, in which:

[0087] FIG. 1 shows a block diagram illustrating the steps involved in a process for preparing passivated carbonaceous material in accordance with the present invention;

[0088] FIG. 2 shows schematically a process flow diagram in accordance with a process for preparing passivated carbonaceous material under low temperature carbonisation conditions;

[0089] FIG. 3 shows a schematic diagram of a dryer comprised in an apparatus for preparing passivated carbonaceous material in accordance with the present invention; and,

[0090] FIG. 4 shows schematically a process flow diagram in accordance with a process for preparing passivated carbonaceous material under medium temperature carbonisation conditions.

DETAILED DESCRIPTION OF THE PREFERRED EMBODIMENTS OF THE INVENTION

[0091] Before the preferred embodiment of the present process and apparatus is described, it is understood that this invention is not limited to the particular materials described, as these may vary. It is also to be understood that the terminology used herein is for the purpose of describing the particular embodiment only, and is not intended to limit the scope of the present invention in any way. It must be noted that as used herein, the singular forms “a”, “an”, and “the” include plural reference unless the context clearly dictates otherwise. Unless defined otherwise, all technical and scientific terms used herein have the same meanings as commonly understood by one of ordinary skill in the art to which this invention belongs.

[0092] Additionally, in considering the Figures, it will be appreciated that for purposes of clarity certain details of construction are not provided in view of such details being conventional and well within the skill of the person skilled in the art once the invention is disclosed and explained. For example, a hopper, a conveyor, a bag house filter, a cyclone, a multi-hearth furnace, flues, blowers and valves may be any such known commercially available components with the exception that such components may be modified as necessary by one skilled in the art to be employed in the overall process of the present inventions discussed herein. In addition, many control devices which are conventional and standard in chemical processing have been omitted for clarity of illustrating and describing the invention. For example, control valves, thermocouples, thermistors, coupled with suitable servo circuits are readily available and conventionally used for measuring and controlling temperature and process flow.

[0093] Referring to the figures in which like numerals refer to like features, in FIG. 1 there is shown a block diagram of the steps of a process **10** for preparing a passivated carbonaceous material.

[0094] The steps of the process **10** include drying **2** a carbonaceous material feed stream, treating **3** the dried carbon-

aceous material with volatile matter, and devolatilising **4** the dried carbonaceous material and forming passivated carbonaceous material.

[0095] The terms “devolatilisation” or “devolatilising” as used herein refers to a process that involves thermal decomposition of carbonaceous material, typically coal, in a controlled oxygen atmosphere with production of volatile matter, liquor (low molecular weight liquids), tar (high molecular weight liquids), and char or coke. There is some variation of the product distribution with the temperature of thermal decomposition. It will be appreciated that the process of carbonisation of carbonaceous materials undertaken at low, medium or high temperature conditions is encompassed by the terms “devolatilisation” and “devolatilising”.

[0096] The term “volatile matter” as used herein refers to those products described previously, exclusive of moisture, given off as gas and vapour. The content of volatile matter in coal can be determined by definite prescribed methods (ASTM, 1981, D2361-66, D3761-79, D3175-77, D3175-77, D3176-74, D3178-73, and D3179-73, and will vary according to the composition of the coal or feedstock materials for the volatile matter.

[0097] The term “passivated carbonaceous material” refers to carbonaceous material which has been treated to be resistant to spontaneous combustion in conditions where carbonaceous material would be reasonably expected to spontaneously combust.

[0098] The term “carbonaceous material” as used herein is defined in the broadest terms and includes coal, coal-based products, charcoal, activated carbon, wood, wood chips, sawdust, biomass, waste rubber including but not limited to vehicle tyres, waste plastic materials, contaminated soils, mixtures thereof and mixtures of said carbonaceous materials with other substances.

[0099] Typically, the carbonaceous material feed stream comprises a plurality of particles of non-agglomerating coal including but not limited to lignite, sub-bituminous coal, bituminous coal, anthracite, and a blend of two or more thereof. Anthracite is a class of non-agglomerating coals as defined by the American Society for Testing and Materials having more than 86 percent fixed carbon and less than 14 percent volatile matter on a dry, mineral-matter-free basis. Bituminous coal is a class of coals as defined by the American Society for Testing and Materials high in carbonaceous matter, having less than 86 percent fixed carbon, more than 14 percent volatile matter on a dry, mineral-matter-free basis, a moisture content from 1.5 to 7 percent, and more than 10,500 Btu/lb (29.68 MJ/kg) on a moist, mineral-matter-free basis. Bituminous coals may be either agglomerating or non-agglomerating coals. Sub-bituminous coal is a class of non-agglomerating coals with a carbon content between 71 and 77 percent and a moisture content to 10 percent, and having a heat value content of more than 8,300 Btu/lb and less than 11,500 Btu/lb on a moist, mineral-matter-free basis. Lignite is a class of brownish-black, low-rank coal defined by the American Society for Testing and Materials as having less than 8,300 Btu/lb (23.46 MJ/kg) on a moist, mineral-matter-free basis. Typically, lignites or brown coal have high oxygen content (up to 30 percent), a relatively low carbon content (60-75 percent on a dry basis) and a high moisture content (30-70 percent).

[0100] The carbonaceous material feed stream can also comprise a plurality of particles of agglomerating coal (or

coking coal) in combination with an anti-caking agent to reduce swelling and agglomeration of the coal particles during carbonization.

[0101] The process of the present invention is particularly suited in respect of a carbonaceous material feed stream comprising a plurality of coal particles of low rank coal with a high moisture content, such as lignite, sub-bituminous coal, and bituminous coal with a moisture content of 10%-70%.

[0102] For example, the process 10 of the present invention is particularly suited for sub-bituminous coal from the Ewington mine in Western Australia having approximately the following composition by weight: 44% fixed carbon, 6% ash, 25% moisture, and 27% volatile matter.

[0103] Although the process 10 with reference to FIGS. 1, 2 and 4 refers to performing the invention with respect to sub-bituminous coal or lignite, it will be appreciated that the process 10 the present invention may be used to prepare passivated dried coal or passivated char from other types of coals, biomass, waste rubber products such as for example tyres, woodchips, and other carbonaceous materials. Alternatively, the process may be used to dry other oxygen sensitive, flammable substances, for example thermal desorption of activated carbon or even contaminated soil.

[0104] Typically, the particles of carbonaceous material are sized less than 50 mm, preferably less than 20 mm, and even more preferably less than 15 mm. Advantageously, with a particle size of less than 20 mm, the particles of carbonaceous material do not tend to suffer excessive stress due to shrinkage and subsequent decrepitation when dried, or at temperatures under which devolatilisation and/or carbonization occurs. Thus, the percentage particle breakdown throughout the process is typically <15%.

[0105] Additionally, the particles do not tend to suffer excessive transient heat transfer. In other words, the temperature at the centre of the particle is similar to the temperature at the surface of the particle, and thus each particle can be rapidly heated or cooled.

[0106] Referring now to the flow diagrams shown in FIGS. 2 and 4, where like numerals refer to like parts throughout, typically the carbonaceous material feed stream is prepared by washing, crushing and classifying to provide coal of suitable quality, quantity and particle size. The carbonaceous material feed stream is fed into a dryer 12 at ambient temperature via a screw conveyor 14, typically at a rate of 90-100 tph.

[0107] The dryer 12 is shown in more details in FIG. 3. The dryer 12 comprises two 20 m long, 3 m diameter co-axial rotary kilns 12a, 12b in fluid communication with one another. However, the dryer 12 is operated as if it were a single rotary kiln, the dual configuration of the rotary kilns 12a, 12b being arranged merely to facilitate control of operating conditions within each rotary kiln 12a, 12b and ensure safe operating conditions. The rotary kilns 12a, 12b are disposed on an angle of 0-10°, preferably 2-5° above the horizontal which facilitates passage of the carbonaceous material feed stream therethrough by gravity. Each rotary kiln 12a, 12b is rotated via its own gearbox and motor. The dryer running gear has a temperature transmitter and a local temperature indicator to the monitor lubricant temperature to ensure the bearings operate properly.

[0108] Additionally, at the end of each rotary kiln 12a, 12b there is a temperature indicator and temperature transmitter PLC instrumentation. The dried carbonaceous material feed stream exiting each rotary kiln 12a, 12b of the dryer 12 is

monitored to ensure that the temperature of the dried carbonaceous material feed stream does not increase more than 10° C. per second, which would indicate imminent spontaneous combustion. In the event of a rapid temperature rise means are provided for water to be sprayed on the dried carbonaceous material feed stream. Explosion flaps are also provided at each transfer box to vent the dryer 12 should the internal pressure exceed 20 kPa (g).

[0109] Each co-axial rotary kiln 12a, 12b houses an internal tube 20a, 20b having a diameter of 1.5 m and 1.8 m, respectively. The external diameter of each co-axial rotary kiln 12a, 12b is about 3 m. The internal tubes 20a, 20b are provided with a thick wall to withstand high temperature conditions. For example, the strength of steel at 650° C. is approximately 30% of its original strength at ambient temperature. Thus the internal tubes 20a, 20b are provided with the thick wall to prevent creep in the steel at temperatures of 650° C. and above.

[0110] The co-axial rotary kilns 12a, 12b are configured to receive the carbonaceous material feed stream in an outer passage 22 between an outer shell of the co-axial rotary kilns 12a, 12b and the internal tubes 20a, 20b. Immediately after passing through the outer passage 22 of rotary kiln 12b, the carbonaceous material feed stream is fed into the outer passage in rotary kiln 12a by a screw conveyor (not shown). The carbonaceous material feed stream then travels through the outer passage 22 of rotary kiln 12a. Typical residence time of the carbonaceous material feed stream in the rotary kilns 12b, 12a is about 30 minutes.

[0111] During the passage of the carbonaceous material feed stream in the outer passage 22 of the rotary kilns 12b, 12a, the carbonaceous material feed stream is heated so that the temperature of the carbonaceous material feed stream progressively increases from ambient temperatures to between 100-400° C., under which temperature conditions the carbonaceous material feed stream is dried. At temperatures >100° C. low temperature devolatilisation commences. Volatile matter is thus evolved from the carbonaceous material feed stream in the dryer 12.

[0112] The carbonaceous material feed stream is heated to temperatures of about 100° C.-400° C. by a counter current flow of a gas stream with low oxygen content at temperatures of 400° C. to 900° C., preferably 600° C. to 800° C.

[0113] The volatile matter evolved in the dryer 12 mixes with the gas stream in the outer passage 22 and is directed in a counter current flow relative to the carbonaceous feed stream. Tar and other organic compounds contained in the volatile matter coat the particles of the carbonaceous material in the dryer 10, plugging the micropores of the particles, thereby passivating the particles against spontaneous combustion.

[0114] The gas stream has a low oxygen (0-5% O₂ v/v), high moisture (up to 50% moisture) content. Typically, the gas stream is generated from an external burner 30 and fed to the outer passage 22 of the rotary kiln 12a via conduit 28, and then from the outer passage 22 of rotary kiln 12a to the outer passage 22 of rotary kiln 12b. The gas stream flows at approximately at 33 m³/s i.e. 37500 kg/h.

[0115] The heat load capacity of the external burner 30 is selected according to the moisture content of the carbonaceous material feed stream. In this particular embodiment the heat load of the external burner 30 is about 18-20 MW. At the commencement of operation of the process of the present invention, the external burner 30 may be fuelled by LPG

combustion, and/or pulverised coal can be conveyed into the combustion chamber thereof, where it mixes with preheated secondary combustion air and combustion takes place. Later in the process, it will be understood that coal gas generated during devolatilisation of the carbonaceous material feed stream can be diverted and fed to the external burner **30** and combusted for heating purposes as a replacement fuel for LPG or PCI.

[0116] The gas stream with a low oxygen content is supplied to the external passages **22b**, **22a** of the rotary kilns **12a**, **12b** and comprises the hot combustion gases produced by the external burner **30**.

[0117] Before being directed to the dryer through conduit **28**, the hot combustion gases pass through a heat exchanger **32** which transfers some of the heat to ambient air to produce a hot air stream.

[0118] The ambient air that is passed through the heat exchanger **32** is supplied by two fans, a Variable Speed Drive (VSD) fan and a soft start fan. The hot air stream leaves the heat exchanger at 650° C. and a flow rate of 33 m³/s through a conduit **26** which is typically a 1.5 m diameter stainless steel duct. Conduit **26** is provided with a butterfly valve to bleed off excess hot air.

[0119] The hot combustion gases leaves the heat exchanger **32** at 400° C.-800° C., typically 650° C., at a flow rate of 33 m³/s. The hot combustion gases travel through conduit **28** which is typically a 1.8 m diameter refractory lined steel pipe. A refractory lining is used to protect the pipe because the hot combustion gas is low in oxygen content and could potentially decarbonise the steel.

[0120] The hot combustion gas tends to cool as it traverses the external passage **22** of the dryer **12** in counter current flow to the carbonaceous material feed stream by virtue of gas-solid heat exchange.

[0121] In order to maintain the drying capacity of the hot combustion gas, the hot air stream produced by heat exchanger **32** is fed simultaneously to the internal tubes **20a**, **20b** of the dryer **12** via conduit **26**. The hot air stream is 400° C. to 800° C., preferably about 600° C.-700° C., and flows at 33 m³/s through the internal tubes **20a**, **20b** in the same direction as the hot combustion gas. One portion of the hot air stream is fed into the internal tube **20a** of the rotary kiln **12a** and the other portion of the hot air stream is fed into the internal tube **20b** of the rotary kiln **12b**.

[0122] Typically, after these two streams pass through rotary dryers **12a**, **12b** their temperatures are reduced to about 200° C. The streams are then recombined and fed as secondary combustion air into the external burner **30** by two fans, a VSD fan and a soft start fan via conduit **24**.

[0123] Thus it will be understood that the dryer **12** is externally heated and oxygen is substantially excluded from contact with the carbonaceous material feed stream and the dried carbonaceous material feed stream produced in the dryer **12**.

[0124] Fine dried coal particles (approximately -2 mm) are entrained in the hot combustion gas and exit the dryer **12** with this gas through conduit **36**. The hot inert gas and fine dried coal particles are separated after leaving the dryer **12** with a plurality of cyclones (not shown). The cyclones have two induced draft fans, a VSD fan and a soft start fan. The fine dried coal particles are removed and stored in a fine coal bin, and can be subsequently briquetted in accordance with a briquetting process described in WO2004/072212.

[0125] The separated combustion gas is now warm, humid and corrosive. After passing through the cyclones the hot

combustion gas travels to two heat recovery regenerators where trace amounts of volatile materials are thermally destroyed in an oxidising environment. These after burners are designed so that around 70% of the heat used in the combustion of these volatiles is regenerated; the remaining heat comes from the air blown through the heat exchanger that arrives at about 650° C. The combustion gas then flows to a scrubber by two scrubber fans, a VSD fan and a soft start fan. The scrubber is chemically active towards acidic gases, in particular SO_x, NO_x, and PO_x. Thickened sludge flows out of the bottom of the scrubber which is sent to the tailings pond.

[0126] Around half of the hot combustion gas is fed back into the external burner **30** to dilute down the oxygen content of the pre-heated combustion air.

[0127] After completion of the drying process, the dried carbonaceous material feed stream can be cooled, stockpiled and stored, or it can undergo further pyrolysis.

[0128] When the dried carbonaceous material feed stream is immediately cooled after completion of the drying process, the dried carbonaceous material feed stream is transferred from the dryer **12** by a conveyor **16** which takes the dried coal feed stream to a further two conveyors. The dried coal feed stream travels at a nominal 100 tph along the conveyors to a coal holding bin **54** disposed above a cooler **50**, such as, for example, a multi hearth fluidised bed cooler. Each of the conveyors is provided with temperature transmitters to monitor the temperature of the dried carbonaceous material feed stream. Similarly, at the coal holding bin **54** disposed above the cooler **50** there are local instruments consisting of a low level switch and a high level switch. The PLC instruments include a level high alarm, a high level sensor and a low level sensor. The dried carbonaceous material feed stream is then fed into the cooler **50** by a screw conveyor **56**.

[0129] The dried carbonaceous material, typically dried low rank coals, are then cooled by mixing the dried carbonaceous material with ambient particulate matter, preferably wet screened coal to produce a solid-solid heat exchange between the two materials. In this way, the inherent heat of the dried carbonaceous material is not only transferred to the particulate matter to facilitate thermal equilibrium, but the thermal energy of the dried carbonaceous material is also utilized to dry the particulate matter and therefore facilitate moisture equilibrium. Cool inert gas, typically comprising N₂, CO₂, and Ar, is also blown through the fluidised bed cooler to help bring the mixed materials to thermal and moisture equilibrium.

[0130] The mixed carbonaceous material is eventually discharged onto a conveyor at a nominal rate of 100 tph, and transported to stockpiling.

[0131] The cool inert gas which has circulated through the cooler is then passed through six 1 m diameter cyclones to remove fine coal particles (-2 mm) entrained in the cool inert gas. The fine coal particles are stored and then transported in a pneumatic conveyor. The de-dusted air is returned as exhaust to the atmosphere via a bag house.

[0132] In an alternative embodiment of the invention, the dried carbonaceous feed material produced in the dryer **12** may undergo further devolatilisation, such as medium temperature carbonization, to produce passivated char.

[0133] Referring to FIG. 3, the dried carbonaceous material feed stream is fed from the dryer **12** by a screw conveyor **16** onto one or more pneumatic conveyors **18**. Typically, the dried carbonaceous material feed stream is already heated to 100-400° C., which reduces the heating load required during

carbonization and improves thermal efficiencies in the system. The dried carbonaceous material feed stream is transported by the pneumatic conveyor(s) **18** in a substantially oxygen free atmosphere (0-5% O₂) composed mostly of N₂, CO₂, and Ar with traces of CO, H₂ and CH₄, at a temperature of 100° C.-500° C., typically 300° C. The inert gas is pressurized via a compressor before being heated. The transport fans exert high pressures on both the inlet and the outlet of the pneumatic conveyor so as only to overcome any pressure drops associated with transport of the dried carbonaceous material feed stream, line losses, cyclones and multi-clones.

[0134] Dried carbonaceous material feed stream is then fed into a large cyclone **34** disposed above a pyrolyser **40**, in this instance a multi-hearth furnace **40**. The feed rate of dried carbonaceous material into the pneumatic transport system is controlled by the pressure drop across the cyclone **34**. The inert gas is re-circulated at 20 m/s through the system except in the portion of the system immediately before the cyclone **34** where the flow rate is 12 m/s.

[0135] The cyclone **34** removes particles \sim 1.5 mm thus preventing fine particles being fed to the pyrolyser **40**. The separated inert gas is recirculated and the fines are fed to either the external burner **30** or to a briquette plant.

[0136] In this embodiment, one or more multi-hearth furnaces **40** are employed as the pyrolyser.

[0137] Further, additional thermal efficiency is obtained in the process of the present invention by feeding the dried carbonaceous material feed stream from the dryer **12** to the pyrolyser **40** at a high temperature, thereby reducing the heat load and gas volume required in the pyrolyser **40**.

[0138] The hot dried carbonaceous material feed stream cascades down through the multi-hearth furnace **40** against a counter current flow of hot gases which rise to the top of the multi-hearth furnace **40**. The hot gases comprise coal gas evolved from the devolatilised carbonaceous material feed stream (i.e. volatile matter), combustion product gas arising from instances of combustion of the carbonaceous material feed stream that occur in the multi-hearth furnace **40**, and hot inert gases fed from the external burner **30** by conduit **38**. The hot inert gases are preheated in the external burner **30** to 650° C. before being delivered to the multi-hearth furnace **40**. However, the majority of the heat for carbonisation will be derived from the combustion of coal gas in the external burner **30**.

[0139] There are significant advantages in feeding a pre-heated dried carbonaceous material feed stream to the pyrolyser, including but not limited to:

[0140] the water vapour content of the coal gas generated during devolatilisation is reduced by pre-drying the coal and venting off the moisture laden gases

[0141] the following undesirable reactions are less likely to occur if the coal gas has a reduced water vapour content

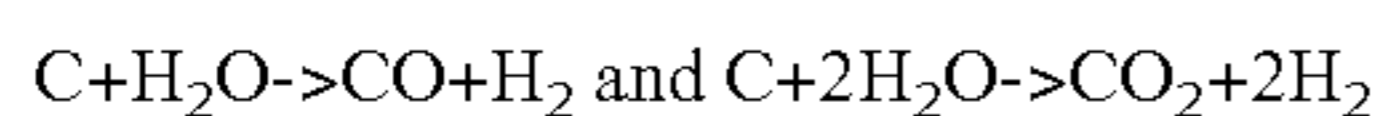

[0142] the formation of carbon monoxide by the following reaction is less likely to occur as carbon dioxide is generally evolved in low temperature pyrolysis and is vented before the dried carbonaceous material is transferred to the pyrolyser **40**

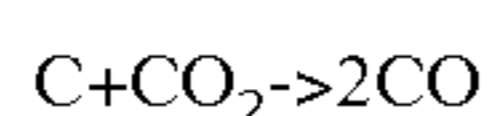

[0143] combustion within the pyrolyser **40** is minimized.

[0144] Typically, the dried carbonaceous material feed stream cascades down through each of the hearths in counter

current flow with a stream of gas with a low oxygen content of less than 5% and preferably less than 1% comprising hot combustion fuel gases generated in each of the hearths and/or an external burner. Under the operating conditions of the multiple hearth furnace, the dried carbonaceous material feed stream thermally decomposes to form char and a gas product stream containing volatile matter. The gas product stream mixes with the hot combustion fuel gases and is directed in a counter current flow through the multi-hearth furnace. In this way, volatile matter contained in the gas product stream is brought into contact with the dried carbonaceous material feed stream immediately prior to its ingress to the multi-hearth furnace, as described above, and additionally as the dried carbonaceous material feed stream cascades through the multi-hearth furnace and undergoes carbonization. Hydrophobic species in the volatile matter coat the particles in the dried carbonaceous material feed stream, plug the micropores of the dried particles as described above, and passivate the particles of dried carbonaceous material against adsorption of water and oxygen, and thus spontaneous combustion.

[0145] As the dried carbonaceous material feed stream traverses the multi-hearth furnace **40**, the dried carbonaceous material feed stream is heated to temperatures of about 600° C.-850° C. by a counter current flow of hot gases as described above, at which temperatures the dried carbonaceous material feed stream is carbonized and converted to char.

[0146] Volatile matter is also evolved from the dried carbonaceous material feed stream at these temperatures. The volatile matter mixes with the hot gases and is subsequently directed in a counter current flow against the dried carbonaceous material feed stream. Thus the volatile matter coats the dried particles, plugging the micropores, and reducing the absorption of water and oxygen. At the temperatures in the multi-hearth furnace **40** the tar and the particles undergo pyrolysis. Pyrolytic rupture of functional groups attached to aromatic and hydro-aromatic units of the coal particle structure leads to the release of low molecular weight, reactive, free radicals (fragments) and stabilisation of the former fragment sites by hydrogen. Thus hydrophilic polar-functional groups are removed from the coal particles and replaced by hydrophobic aromatic coating. During low temperature carbonisation this process can produce a passivated carbonaceous material with similar properties to a reduced sulphur, pseudo-bituminous coal from low rank coal. The passivated carbonaceous material may be as chemically stable as any other naturally occurring bituminous coal. Upon further heating the tar coating mobilises and in the subsequent pyrolysis phase the tar provides the hydrogen used to stabilise more radical sites on the coal particle thus producing a passivated char with similar properties to a reduced sulphur, pseudo anthracite coal.

[0147] The mixed coal and combustion gases produced and used in the multi-hearth furnace can be processed in several ways including but not limited to combustion to produce electricity, or used to make fertilizer. Additionally, as described above, the coal gas can be used as an alternative fuel source for the external burner **30**. Regardless of the method of gas utilization, there is provided a safe and environmentally acceptable method of flaring the mixed gases generated in the multi-hearth furnace.

[0148] The passivated char exits the multi-hearth furnace and can be quenched by water and cool inert gas in a manner well known to a person skilled in the art, including using a

multi-hearth cooler **50** as described above, before being cooled to ambient temperature, stockpiled and loaded out. The passivated char produced in the pyroliser is at greater temperatures than the passivated dried carbonaceous material produced in the dryer **12**. Thus, due to the potential to generate explosive gases and dusts within the cooler **50**, as a precautionary measure, liquid water is not introduced to the cooler **50** as a quenching medium until the temperature of the passivated char is below 200° C.

[0149] The passivated char produced by the above described process from the above described coal feedstock has approximately the following composition by weight: 81.3% fixed carbon, 11.9% ash, 2% moisture, and 5% volatile matter.

[0150] Alternatively, the hot passivated char is blended with wet screened coal of the above described composition to produce a blended carbonaceous material with the following composition by weight: 64.8% fixed carbon, 9.2% ash, 10% moisture, and 14.7% volatile matter.

[0151] The process **10** of the present invention can also be conducted under conditions wherein the carbonaceous feed material undergoes high temperature carbonisation, as described in the following example.

EXAMPLE

[0152] Crushed coal from the Ewington mine in Western Australia (100%-15 mm) at 28% moisture is fed at 49 tph to a 16.5-m long five cell fluidised bed dryer. The coal in the fluidised bed dryer is heated with a flow (28,500 kg/h) of waste gas containing 1.6% (m/m) O₂ at temperatures of 800° C. produced in a 10 MW burner. The coal feed stream has a residence time of 9 to 10 minutes in the dryer. The last cell of the dryer is heated by the off gas generated from the pyrolysing means in this system.

[0153] Hot (150° C.) dry coal is fed to a 13.2-m long refractory lined carboniser via a gas lock feeder. The dried coal is heated to 1,300° C. These high temperatures are generated by feeding hot air (800° C.) to the carboniser which combusts with some of the coal gas evolved during pyrolysis. The coal gas flows in a counter-current direction to the flow of the coal/char feed stream. The total residence time of the char feed stream held above 900° C. is between 11 and 12 minutes. Approximately 24,500 kg/h of dry char is produced. Excess coal gas and combustion gases are collected.

[0154] The carboniser feeds three 9.9-m long refractory lined coolers which depress the char temperature from 1,300° C. to less than 500° C. These coolers are fed a counter-current flow of coal inert gas. The quenched char is then fed to a further six steel refractory coolers which reduce the gas temperature to below 70° C. The moisture content of the char is raised to about 6% to suppress dust.

[0155] The above-described high temperature carbonisation system has a nominal capacity of 190,000 tpa of passivated char with 6% moisture, 2% volatile matter content.

Example 2

Trial Data

[0156] Collie coal, with 24% moisture, was pre-dried in an oven under nitrogen at 120° C. This coal was then heated at 5° C./min until it reached 300° C. The mass lost was 0.6% and the equilibrium moisture was 6.5%. The same dried coal was placed in an oven for 10 minutes at 400° C. The resulting mass

loss was 2.6% and the equilibrium moisture was 4.5%. The feed coal typically has an equilibrium moisture of about 13%.

[0157] A large scale trial was performed using a rotary kiln with recycled coal gas and air dried coal. The results are presented below in Table 1. The coal residence time was 20 minutes to heat the coal to an average discharge temperature of 266° C.

TABLE 1

Low Temperature Carbonized Coal						
	Total Moisture	Volatile Level	Ash	Fixed Carbon	Sulfur	Specific Energy MJ/kg
feed coal (gar)	25.5%	27.2%	3.60%	43.7%	0.55%	21.28
feed coal (db)		36.5%	4.83%	58.7%	0.74%	28.56
carbonised coal (gar)	8.5%	26.0%	5.5%	60.0%	0.66%	27.4
carbonised coal (db)		28.4%	6.0%	65.7%	0.72%	29.2

[0158] The overall yield was 65.6% on wet basis or 82.8% yield on dry basis. The increase in specific energy was 28.8% and the reduction in sulfur was 215%. The drying and carbonization energy was 15.5% of total energy throughput.

[0159] A higher degree of carbonization was trialed using a heating rate of 10° C. per minute and dry coal pre-heated to 100° C. for 20 minutes. The results are presented below in Table 2. The coal residence time was 60 minutes to heat the coal to an average discharge temperature of 700° C. The carbonized coal was cooled using inert gas.

TABLE 2

Mid Temperature Carbonized Coal						
	Total Moisture	Volatile Level	Ash	Fixed Carbon	Sulfur	Specific Energy MJ/kg
feed coal (gar)	24.5%	25.75%	3.00%	46.55%	0.20%	20.9
feed coal (db)		33.82%	3.97%	61.90%	0.26%	27.6
carbonised coal (gar)	7.9%	12.0%	5.25%	73.7%	0.22%	32.1
carbonised coal (db)		13.0%	5.70%	80.0%	0.24%	35.1
	C	H	N	S	O	
feed coal (db)	77.87%	4.05%	1.64%	0.32%	17.12%	
carbonised coal (db)	87.0%	5.61%	2.16%	0.24%	5.02%	

[0160] The overall yield was 57.1% on wet basis or 65.7% yield on dry basis. The increase in specific energy was 53% and the reduction in sulfur was 37%. The drying and carbonization energy was 12.6% of total energy throughput.

[0161] From the above description of the preferred embodiment of the process of preparing passivated carbonaceous material in accordance with the invention, it will be evident that the process has significant advantages compared to the prior art processes, including the following advantages:

(1) The process does not produce excessive fine particles due to the deliberate sizing of the feed stock.

(2) The economy of this process is improved by:

[0162] drying the carbonaceous material prior to carbonisation;

[0163] feeding the carboniser with hot dried carbonaceous material;

[0164] directing the coal gas containing volatile matter to flow counter current to the carbonaceous material feed stream; and

[0165] directly heating the carbonaceous material feed stream by partially combusting the carbonaceous material feed stream and the coal gas in the pyroliser.

[0166] coal gas containing volatile matter is also burnt outside the carboniser to provide heat for the process.

(3) The process can use a variety of feed stocks but in particular it is readily suited to removing oxygen and organic sulphur from lignite, sub-bituminous and bituminous coals.

(4) The process prepares a passivated char from low rank coals and reduces the risk of spontaneous combustion. Thus it is expected that these coals will be the prime feed stock.

(5) Drier, pneumatic transport and coal gases are separated where possible and are controlled in terms of temperature, flow and pressure independently

(6) The process is not equipment limited as it could employ fluidised beds, multi-hearth furnaces or rotary kilns or a combination of these unit operations.

(7) The activity of the tarry material in the coal gas is greatly increased by pre-drying the coal and not combining this drier gas with the carbonizing gas. Thus the effect of moisture stabilization can occur at lower temperature if there is a pre-drying step due to less coal gas being required.

[0167] Numerous variations and modifications will suggest themselves to persons skilled in the relevant art, in addition to those already described, without departing from the basic inventive concepts. All such variations and modifications are to be considered within the scope of the present invention, the nature of which is to be determined from the foregoing description.

[0168] For example, the process of the present invention can be applied to other heat sensitive, flammable substances, for example thermal desorption of activated carbon or even contaminated soil.

1. A process for preparing a passivated carbonaceous material comprising the steps of:

- a) drying a carbonaceous material feed stream;
- b) treating the dried carbonaceous material with volatile matter, and
- c) devolatilising the treated dried carbonaceous material feed stream and forming the passivated carbonaceous material and volatile matter.

2. The process according to claim 1, wherein the step of pre-conditioning the dried carbonaceous material feed stream comprises contacting the dried carbonaceous material feed stream with a gas stream containing volatile matter.

3. The process according to claim 2, wherein the gas stream containing volatile matter is directed in a counter current flow relative to the dried carbonaceous material.

4. The process according to claim 2, wherein the volatile matter contained in the gas stream comprises volatile matter evolved during step c).

5. The process according to claim 4, wherein the volatile matter evolved during devolatilisation of the dried carbonaceous material is augmented by doping the carbonaceous material feed stream with materials containing large amounts of hydrophobic aromatic moieties.

6. The process according to claim 2, wherein the volatile matter contained in the gas stream comprises volatile matter

evolved from devolatilisation of a volatile matter feedstock distinct and separate from the carbonaceous material feed stream of the present process.

7. The process according to claim 6, wherein the volatile matter feedstock comprises materials containing large amounts of hydrophobic aromatic moieties.

8. The process according to claim 2, wherein the volatile matter contained in the gas stream comprises volatile matter evolved during step a).

9. The process according to claim 1, wherein the step of drying the carbonaceous material feed stream comprises heating the carbonaceous material feed stream from about 100° C. to 400° C.

10. The process according to claim 1, wherein the drying step is conducted under a low oxygen (0-5% O₂ v/v) and high moisture (up to 50% v/v) atmosphere.

11. The process according to claim 9, wherein the carbonaceous material feed stream is directly heated.

12. The process according to claim 11, wherein the carbonaceous material feed stream is directly heated by contacting the carbonaceous material feed stream with a hot gas stream having a low oxygen content.

13. The process according to claim 12, wherein the oxygen content of the hot gas stream is less than 5% v/v.

14. The process according to claim 13, wherein the oxygen content of the hot gas stream is less than 1% v/v.

15. The process according to claim 12, wherein the hot gas stream is contacted with the carbonaceous material feed stream in a countercurrent direction relative to the carbonaceous material feed stream.

16. The process according to claim 12, wherein volatile matter evolves at the temperatures at which the carbonaceous material feed stream is dried.

17. The process according to claim 16, wherein the volatile matter evolved during step a) mixes with the hot gas stream and is directed in a countercurrent flow relative to the carbonaceous material feed stream, and subsequently contact the dried carbonaceous material thereby treating the dried carbonaceous material.

18. The process according to claim 12, wherein the step of contacting the dried carbonaceous material with a gas stream containing volatile matter is facilitated by directing a countercurrent flow of the hot gas stream relative to the dried carbonaceous material, whereby the hot gas stream is used to heat the carbonaceous material feed stream to temperatures at which step a) is performed.

19. The process according to claim 1, wherein step a) and step b) are performed at substantially the same time.

20. The process according to claim 1, wherein the step of devolatilising the dried carbonaceous material comprises heating the dried carbonaceous material from about 400° C. to 900° C.

21. The process according to claim 20, wherein the step of devolatilising the dried carbonaceous material comprises heating the dried carbonaceous material from about 600° C. to 800° C.

22. The process according to claim 1, wherein the devolatilising step is conducted under a low oxygen (0-5% O₂ v/v) atmosphere.

23. The process according to claim 20, wherein the dried carbonaceous material is directly heated.

24. The process according to claim **23**, wherein the dried carbonaceous material is directly heated by contacting the dried carbonaceous material with a hot gas stream having a low oxygen content.

25. The process according to claim **24**, wherein the oxygen content of the hot gas stream is less than 5% v/v.

26. The process according to claim **25**, wherein the oxygen content of the hot gas stream is less than 1% v/v.

27. The process according to claim **24**, wherein the same hot gas stream is contacted with the dried carbonaceous material in a countercurrent direction relative to the dried carbonaceous material.

28. The process according to claim **24**, wherein the same hot gas stream is used in step c) and then subsequently in step a).

29. The process according to claim **28**, wherein the volatile matter mixes with the hot gas stream and is directed in a countercurrent flow relative to the dried carbonaceous material, and subsequently contacts the dried carbonaceous material located upstream, thereby treating the dried carbonaceous material before it is devolatilised.

30. The process according to claim **1**, wherein the passivated carbonaceous material feed stream produced by the process of the present invention has its moisture content reduced to between 0-20% moisture and its volatile matter content reduced to 0-25% in comparison with the moisture and volatile matter content of the carbonaceous material feed stream.

31. The process according to claim **1**, further comprising the step of quenching the passivated carbonaceous material.

32. The process according to claim **31**, wherein the passivated carbonaceous material is quenched with water and/or cool inert gas.

33. The process according to claim **31**, wherein the passivated carbonaceous material is quenched with untreated carbonaceous material, including but not limited to wet screened coal.

34. A system for preparing passivated carbonaceous materials comprising:

- a dryer for drying a carbonaceous material feed stream;
- a pyrolyser for devolatilising dried carbonaceous material and forming passivated carbonaceous material and volatile matter; and
- a carrier vehicle for facilitating contact of volatile matter with the dried carbonaceous material.

35. The system according to claim **34**, wherein the dryer comprises a rotary kiln, a multiple hearth furnace (MHF), flash dryer, or a circulating fluid bed (CFB).

36. The system according to claim **35**, wherein the rotary kiln is configured at an angle of up to 10° above the horizontal to facilitate passage of the carbonaceous material feed stream through the rotary kiln under gravity.

37. The system according to claim **35**, wherein the rotary kiln is provided with a means to rotate the rotary kiln about its central longitudinal axis, and the rotational speed thereof is typically selected to correspond with the length of the rotary kiln such that a residence time of the carbonaceous material feed stream in the rotary kiln is about 15-40 minutes.

38. The system according to claim **34**, wherein the dryer is arranged to heat the carbonaceous material feed stream to 100° C. to 400° C.

39. The system according to claim **38**, wherein the dryer is heated by a hot gas stream (400° C. to 800° C.) having a low oxygen content.

40. The system according to claim **39**, wherein the oxygen content of the hot stream of gas is less than 5% v/v and preferably less than 1% v/v.

41. The system according to claim **34**, wherein the pyrolyser for devolatilising the dried carbonaceous material feed stream and forming the passivated carbonaceous material and volatile matter comprises any one or more in combination of a rotary kiln, multiple hearth furnace (MHF), or a circulating fluid bed (CFB).

42. The system according to claim **41**, wherein the dried carbonaceous material feed stream in the pyrolyser is directly heated with a hot gas stream having a low oxygen content to temperatures of about 600° C.-800° C.

43. The system according to claim **42**, wherein the oxygen content of the hot gas stream is less than 5% v/v and preferably less than 1% v/v.

44. The system according to claim **38**, wherein the system is further provided with an external burner to generate the hot gas stream used for directly heating the pyrolyser and heating the dryer of the system, respectively.

45. The system according to claim **44**, wherein the hot gas stream is directed in counter current flow against the dried carbonaceous material in the pyrolyser and the carbonaceous material feed stream in the dryer.

46. The stream according to claim **45**, wherein the hot gas stream combines with the volatile matter evolved in the gas pyrolyser and thus acts as the carrier vehicle for the volatile matter.

47. The system according to claim **34**, wherein the system further comprises a means for feeding the dried carbonaceous material to the pyrolyser.

48. The system according to claim **47**, wherein the means for feeding the dried carbonaceous material to the pyrolyser comprises a closed pneumatic system.

49. A process for reducing inherent moisture in and/or increasing a specific energy of a carbonaceous material comprising the steps of:

- a) drying a carbonaceous material feed stream; and
- b) carbonising the dried carbonaceous material by contacting the dried carbonaceous material with a counter current gas stream having a low oxygen content.

50. The process according to claim **49**, wherein the gas stream is contacted with the dried carbonaceous material at a temperature of between 400° C. and 800° C.

51. The process according to claim **49**, wherein the oxygen content of the gas stream is less than 5%.

52. The process according to claim **51**, wherein the oxygen content of the gas stream is less than 1%.

53. The process according to claim **49**, wherein steps a) and b) are both carried out by contacting the carbonaceous material with the gas stream having a low oxygen content whereby said gas stream initially dries the carbonaceous material and then proceeds to carbonise the carbonaceous material.

54. The process according to claim **49**, wherein the gas stream contains volatile matter.

55. The process according to claim **54**, wherein the volatile matter evolves during step b) and mixes with the gas stream.

56. The process according to claim **54**, wherein the volatile matter evolves during step a) and mixes with the gas stream.

57. A process for improving the coking characteristics of non-coking carbonaceous material comprising the steps of:

- a) drying a non-coking carbonaceous material feed stream;
- b) treating the dried non-coking carbonaceous material with volatile matter, and

- c) devolatilising the treated dried non-coking carbonaceous material and forming a carbonaceous material with improving coking characteristics and volatile matter.

58. A process for quenching hot passivated char comprising contacting the hot passivated char with a particulate material.

59. The process according to claim **58**, contacting the hot passivated char with the particulate material comprises blending the hot passivated char with the particulate material and facilitating a solid-solid heat exchange between particles of the hot passivated char and the particulate material.

60. The process according to claim **58** wherein the particulate material is at ambient temperature.

61. The process according to claim **58**, further comprising mixing the hot passivated char and the particulate material blend with a cool inert gas stream to facilitate further quenching thereof.

62. The process according to claim **58**, wherein the particulate material is a carbonaceous material.

63. The process according to claim **62**, wherein the particulate material is wet screened coal.

64. The process according to claim **59**, wherein the step of blending the carbonaceous material and passivated char is conducted in a substantially oxygen-free atmosphere.

65. An apparatus, for use in a continuous process, for passivating carbonaceous material, the apparatus comprising:

- a) an inlet for receiving a feed stream of carbonaceous material;
- b) an inlet for receiving a gas stream containing volatile matter;
- c) a reaction portion configured to allow the carbonaceous material to come into contact with the gas stream containing volatile matter,
- d) an outlet for receiving the passivated carbonaceous material after it has passed through the reaction portion; and
- e) an outlet for receiving the gas after it has passed through the reaction portion.
- 66.** An apparatus for heating oxygen sensitive carbonaceous material in a controlled oxygen environment, the apparatus comprising:
- f) an inlet for receiving a flow of carbonaceous material;
- g) an inlet for receiving a flow of gas with a controlled oxygen content containing volatile matter;
- h) a reaction portion, configured to allow the carbonaceous material to come into contact with the gas with a controlled oxygen content containing volatile matter,
- i) an outlet for receiving the carbonaceous material after it has passed through the reaction portion; and,
- j) an outlet for receiving the gas after it has passed through the reaction portion.

* * * * *