



(19) **United States**

(12) **Patent Application Publication**  
**Zhang et al.**

(10) **Pub. No.: US 2009/0093403 A1**

(43) **Pub. Date: Apr. 9, 2009**

(54) **SYSTEMS, METHODS AND COMPOSITIONS FOR OPTICAL STIMULATION OF TARGET CELLS**

**Publication Classification**

(76) Inventors: **Feng Zhang**, Stanford, CA (US);  
**Karl Deisseroth**, Palo Alto, CA (US);  
**Viviana Gradinaru**, Palo Alto, CA (US)

(51) **Int. Cl.**  
*A61K 38/17* (2006.01)  
*C07H 21/04* (2006.01)  
*C07K 14/435* (2006.01)  
*A61P 25/00* (2006.01)  
*C12N 15/63* (2006.01)  
(52) **U.S. Cl. ....** 514/12; 536/23.5; 530/350; 435/320.1

Correspondence Address:  
**CRAWFORD MAUNU PLLC**  
**1150 NORTHLAND DRIVE, SUITE 100**  
**ST. PAUL, MN 55120 (US)**

(57) **ABSTRACT**

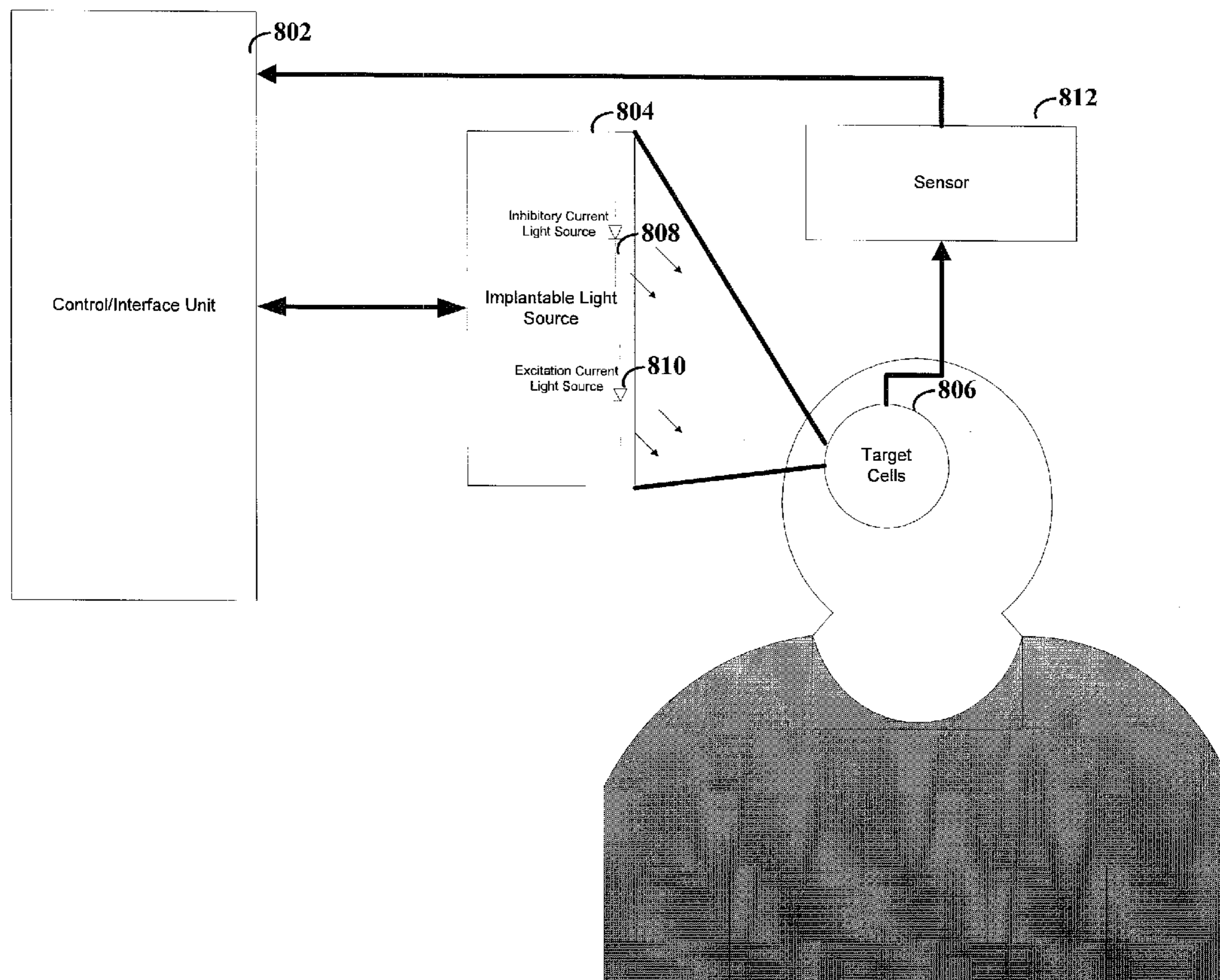
Stimulation of target cells using light, e.g., in vivo or in vitro, is implemented using a variety of methods and devices. One example involves a vector for delivering a light-activated NpHR-based molecule comprising a nucleic acid sequence that codes for light-activated NpHR-based molecule and a promoter. Either a high expression of the molecule manifests a toxicity level that is less than about 75%, or the light-activated NpHR-based proteins are expressed using at least two NpHR-based molecular variants. Each of the variants characterized in being useful for expressing a light-activated NpHR-based molecule that responds to light by producing an inhibitory current to dissuade depolarization of the neuron. Other aspects and embodiments are directed to systems, methods, kits, compositions of matter and molecules for ion pumps or for controlling inhibitory currents in a cell (e.g., in in vivo and in vitro environments).

(21) Appl. No.: **12/041,628**

(22) Filed: **Mar. 3, 2008**

**Related U.S. Application Data**

(60) Provisional application No. 60/904,303, filed on Mar. 1, 2007.



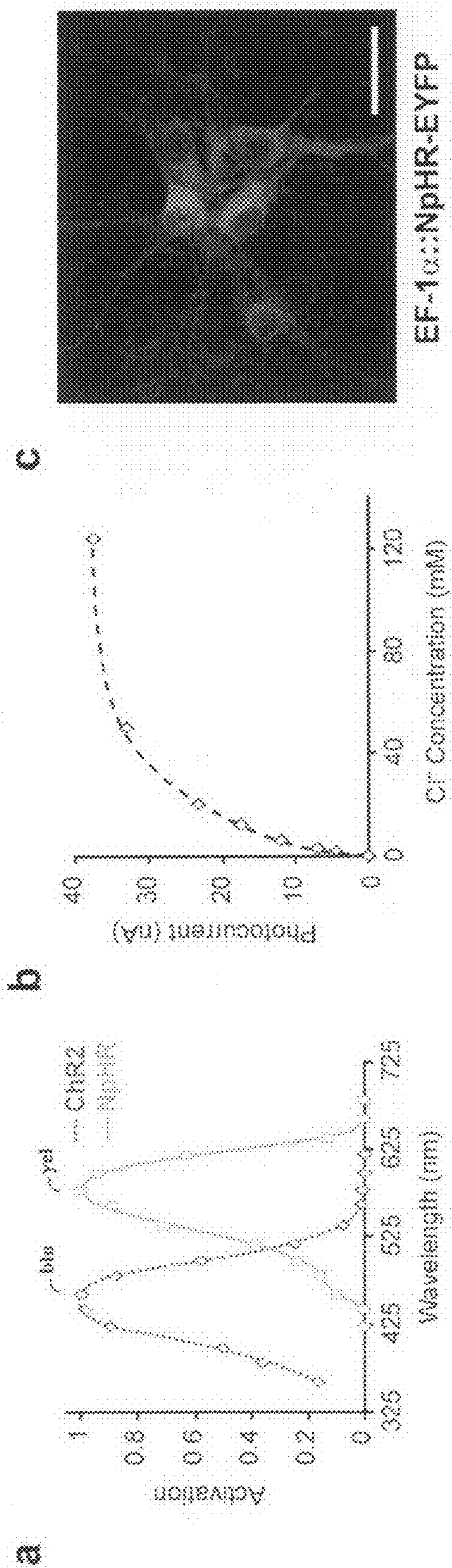


FIG. 1

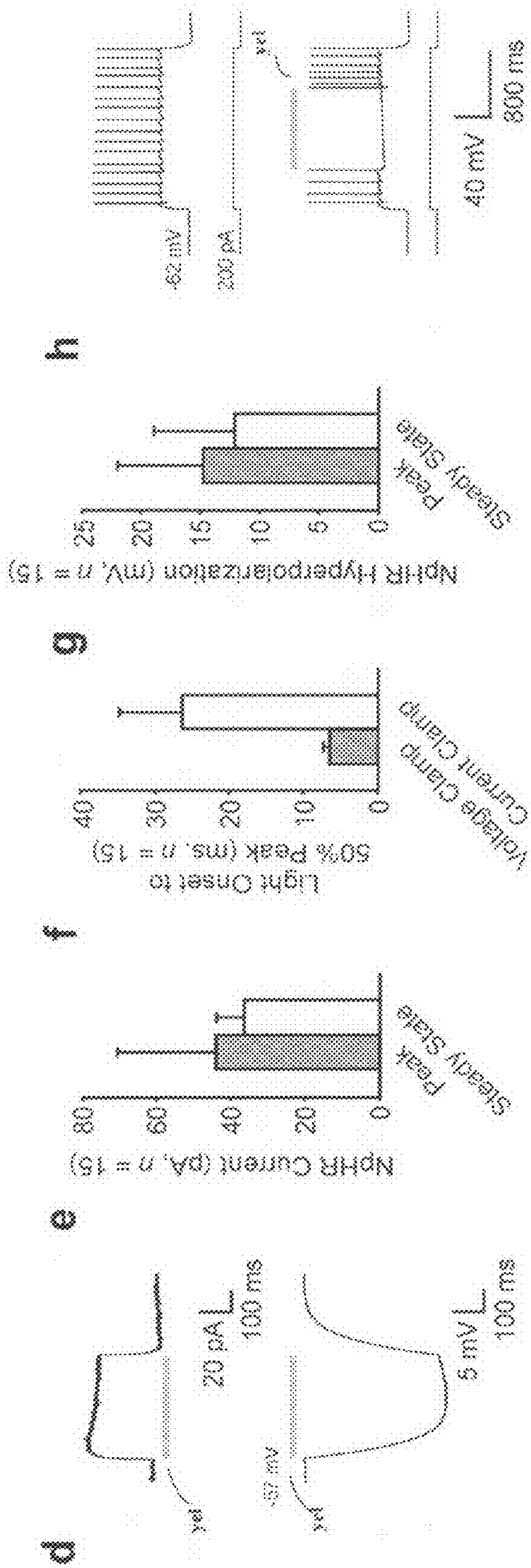


FIG. 1

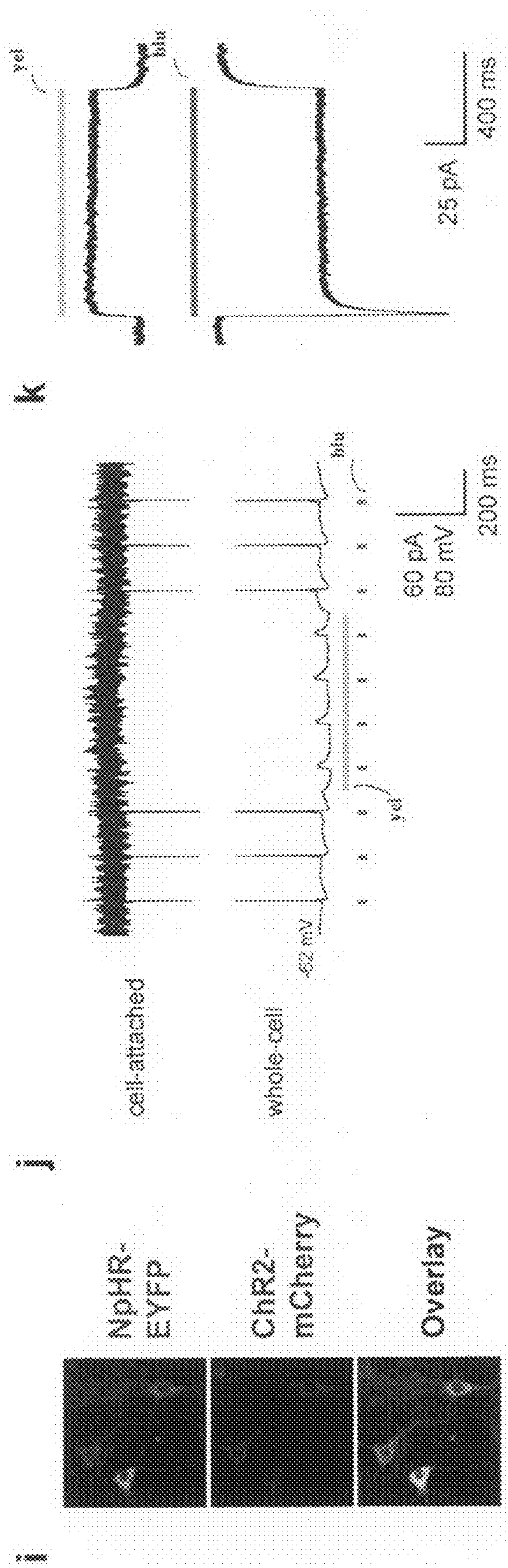


FIG. 1

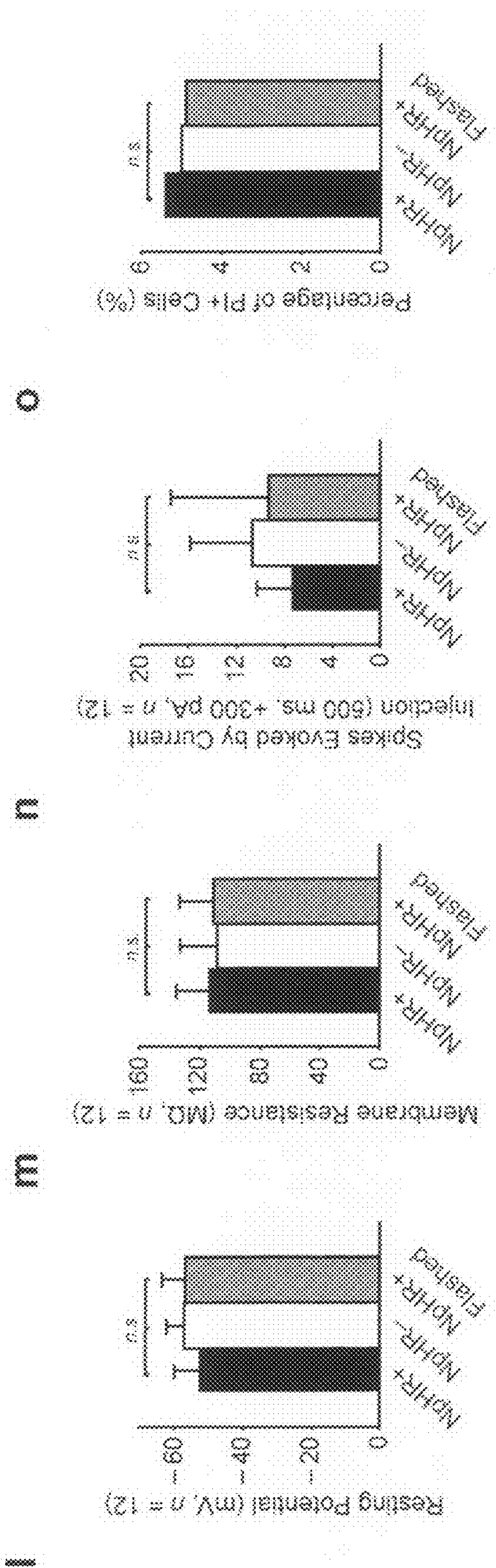


FIG. 1

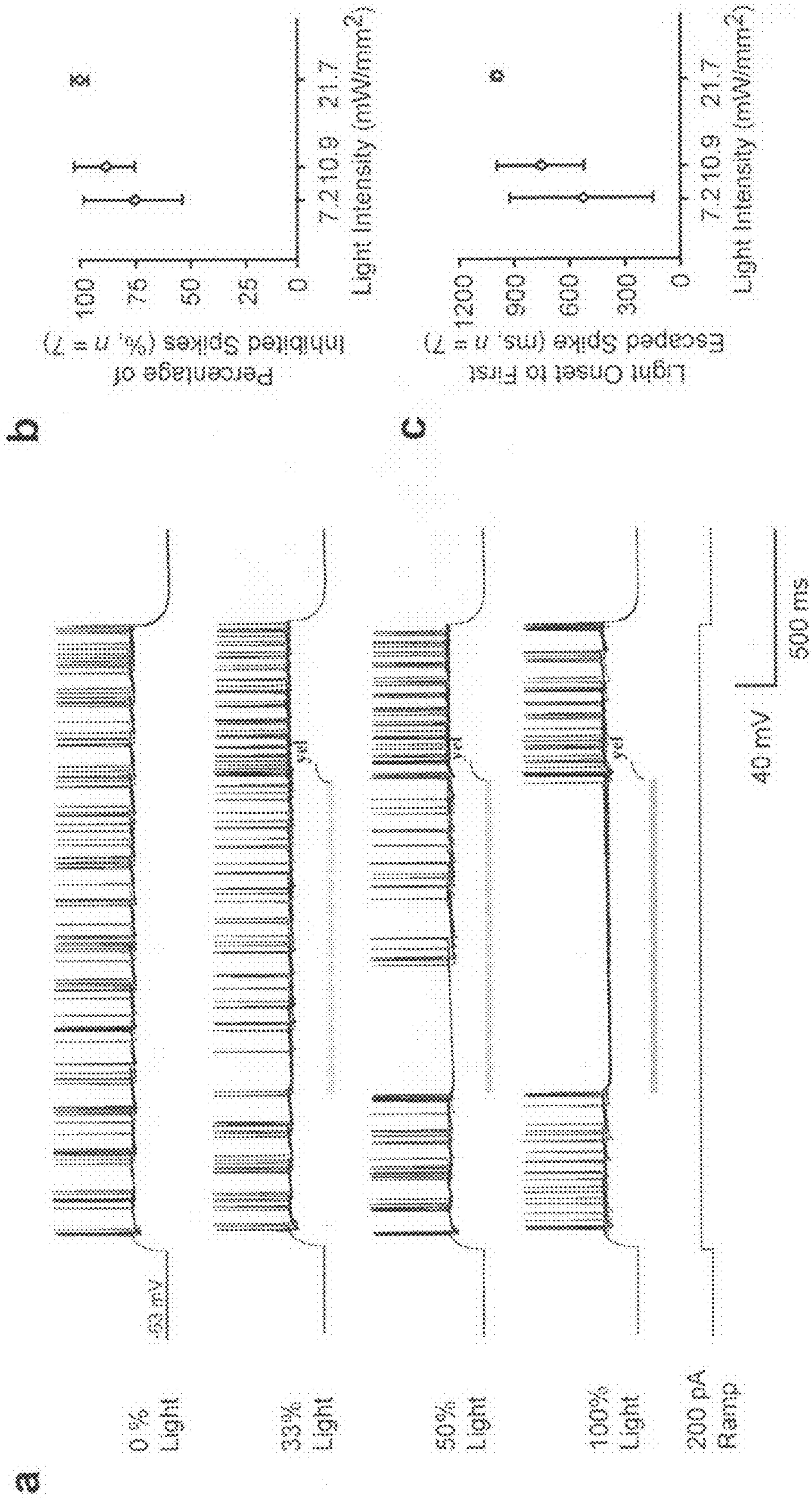
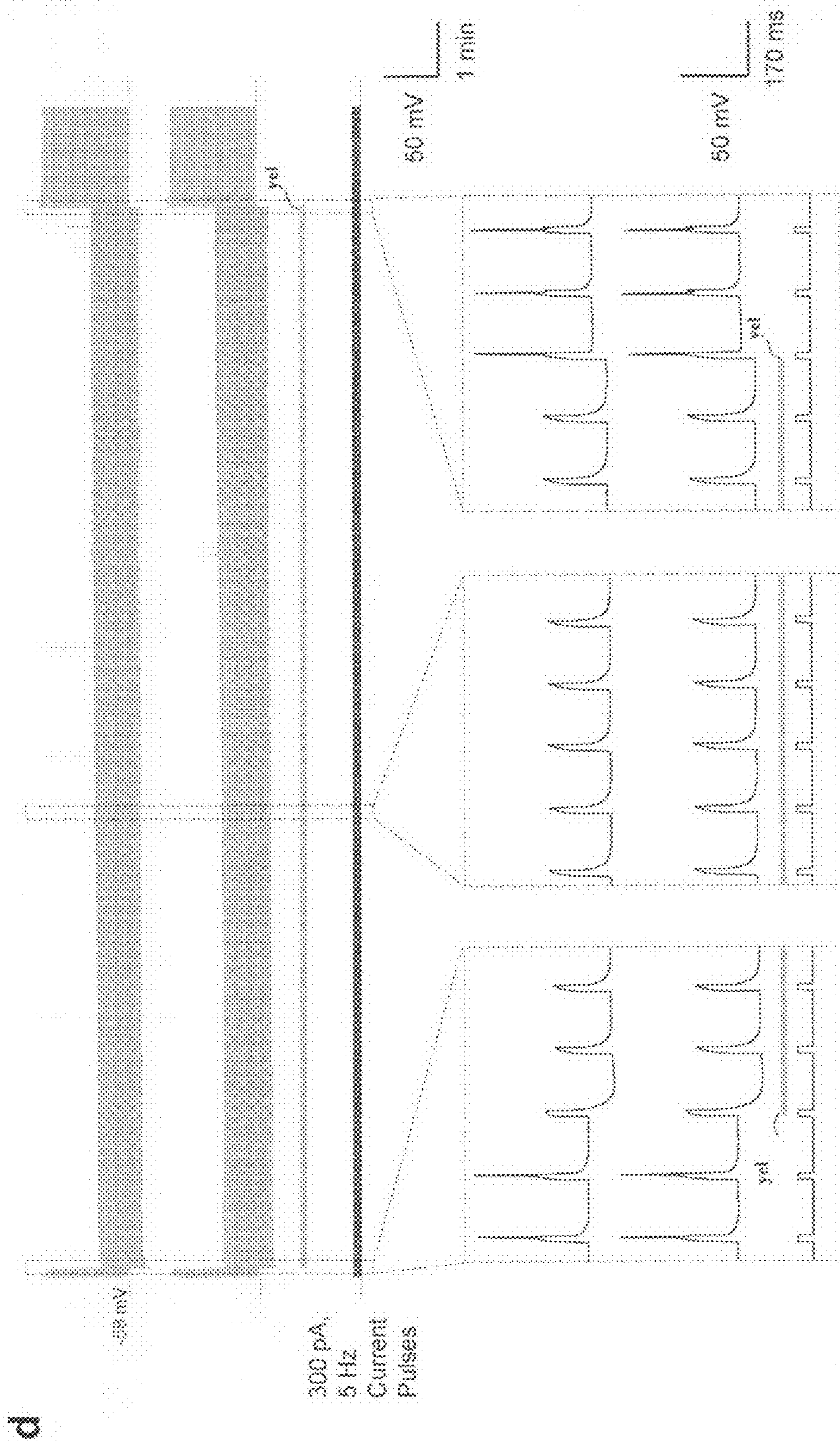
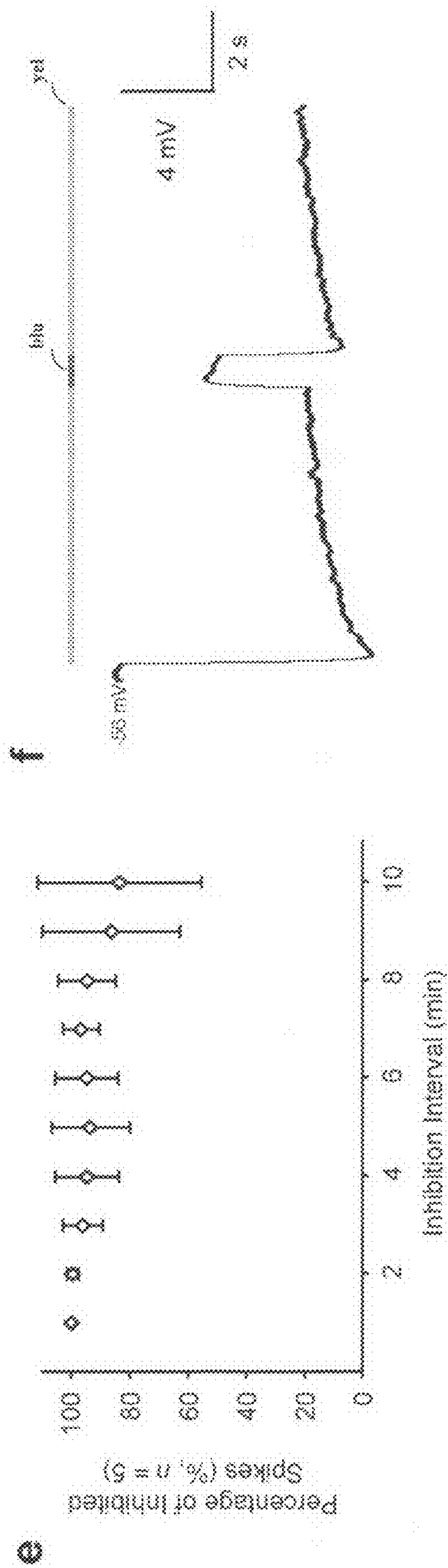


FIG. 2



**FIG. 2**



**FIG. 2**



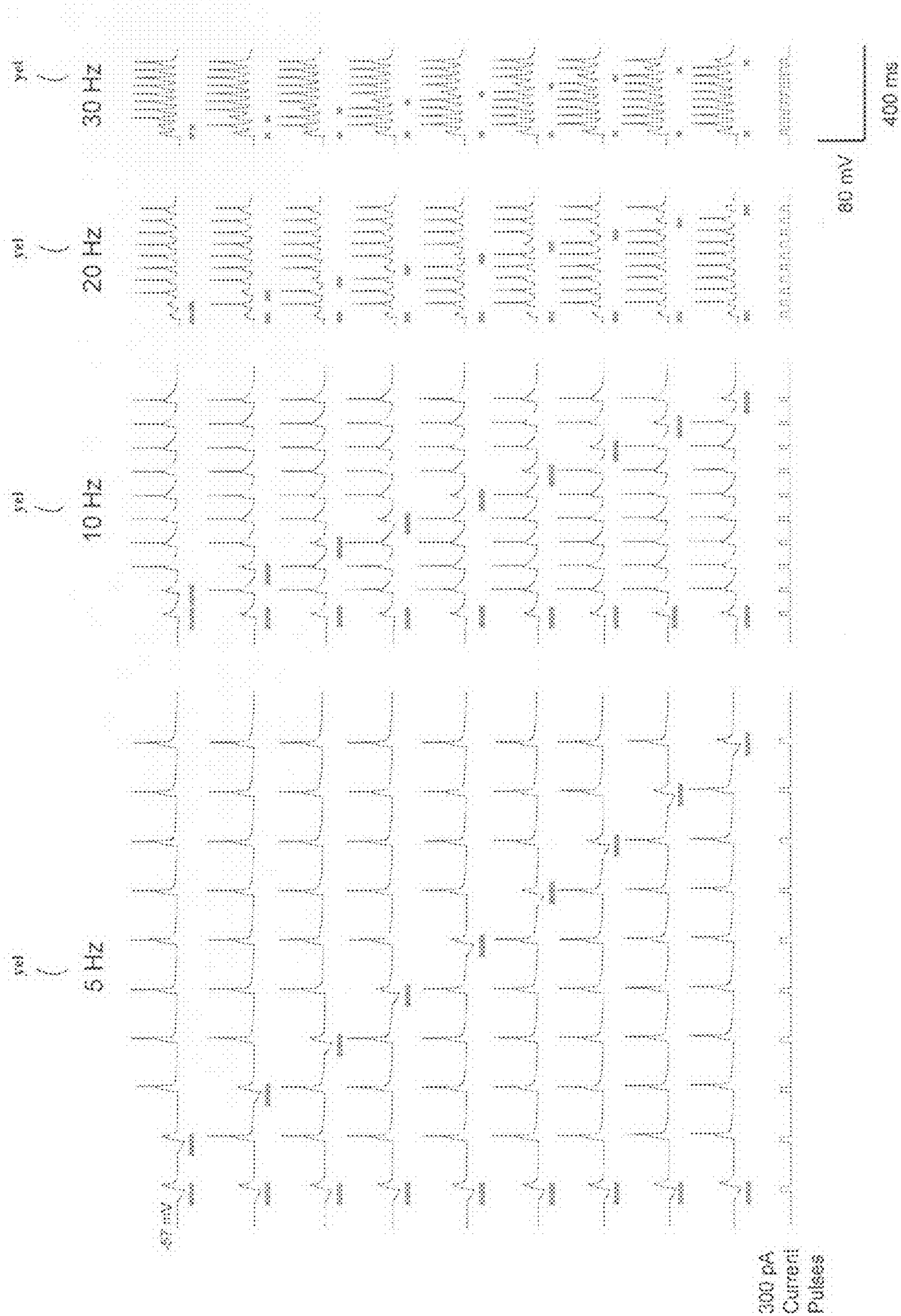
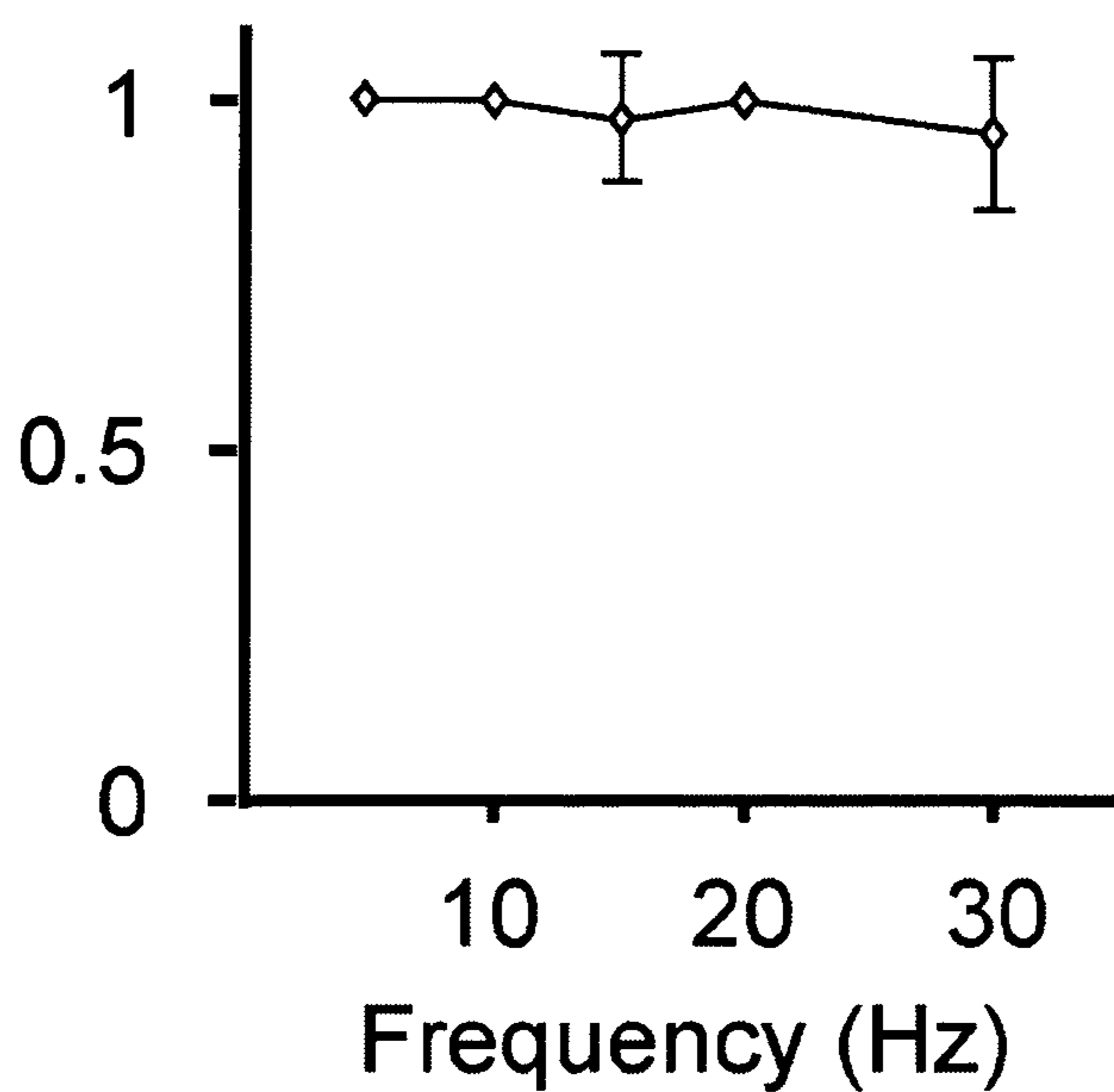


FIG. 3

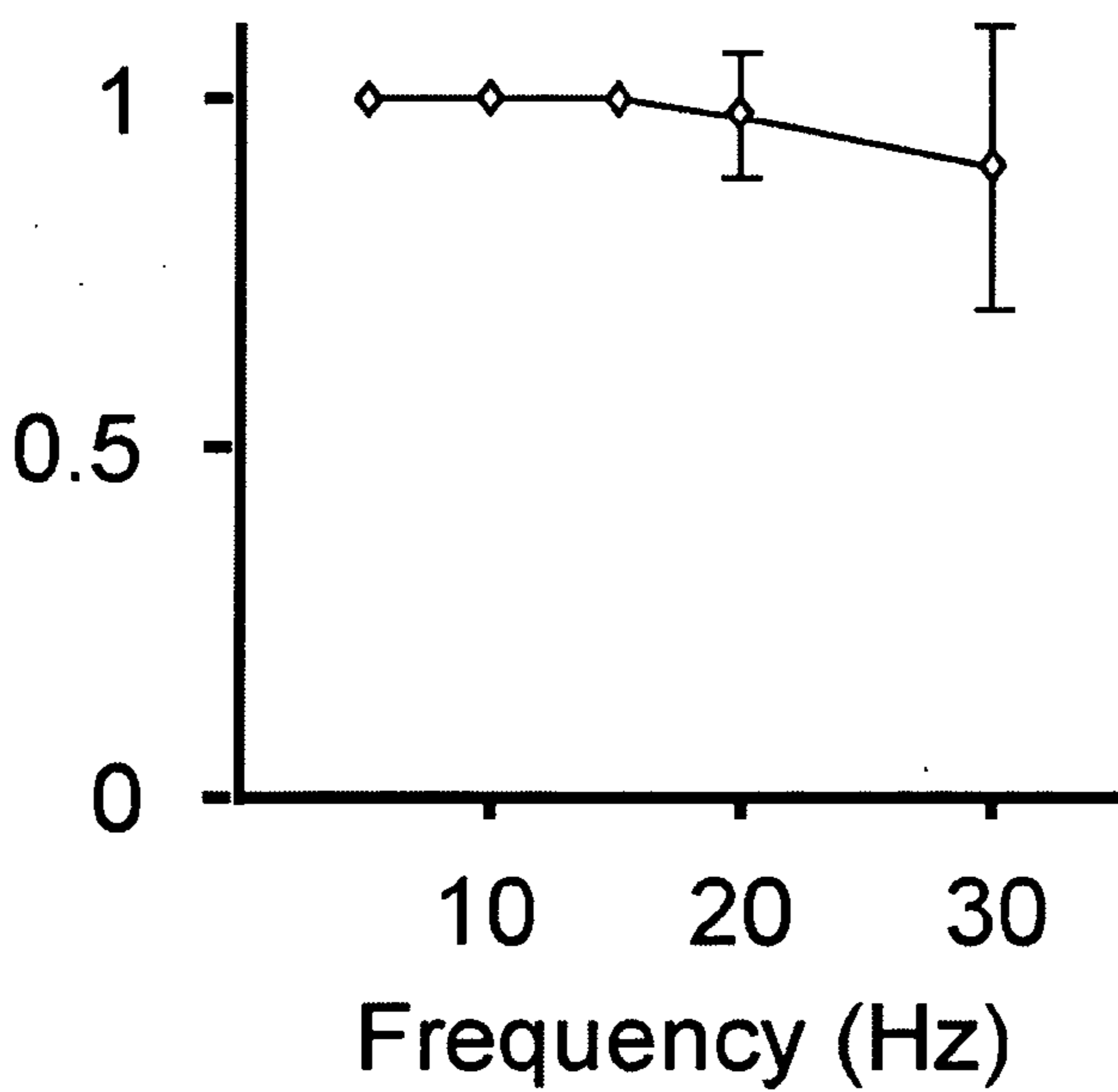
**b**

Probability of Inhibiting the  
Second Spike (2-5,  $n = 6$ )

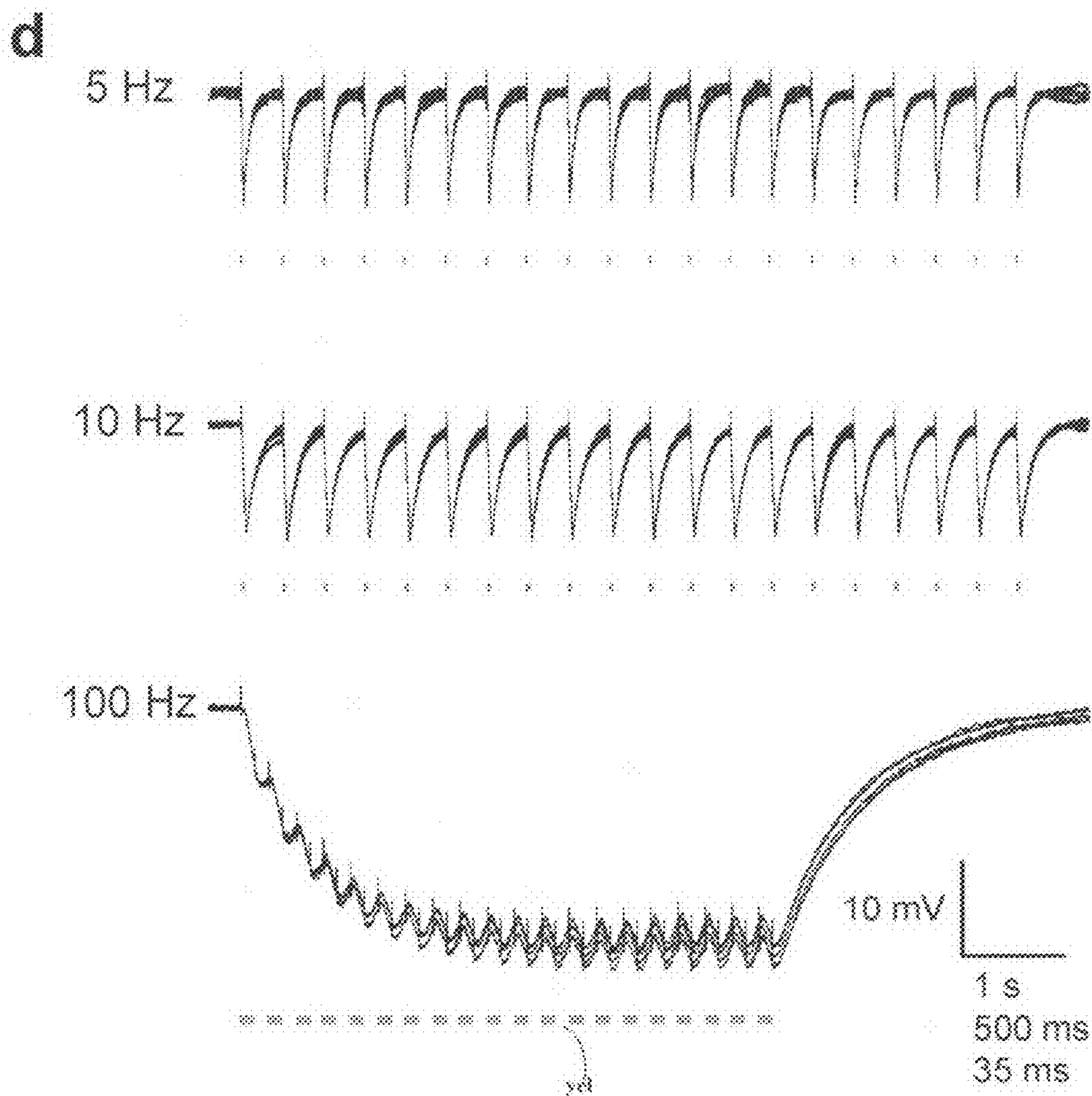


**c**

Probability of Inhibiting the  
Second Spike (6-9,  $n = 6$ )

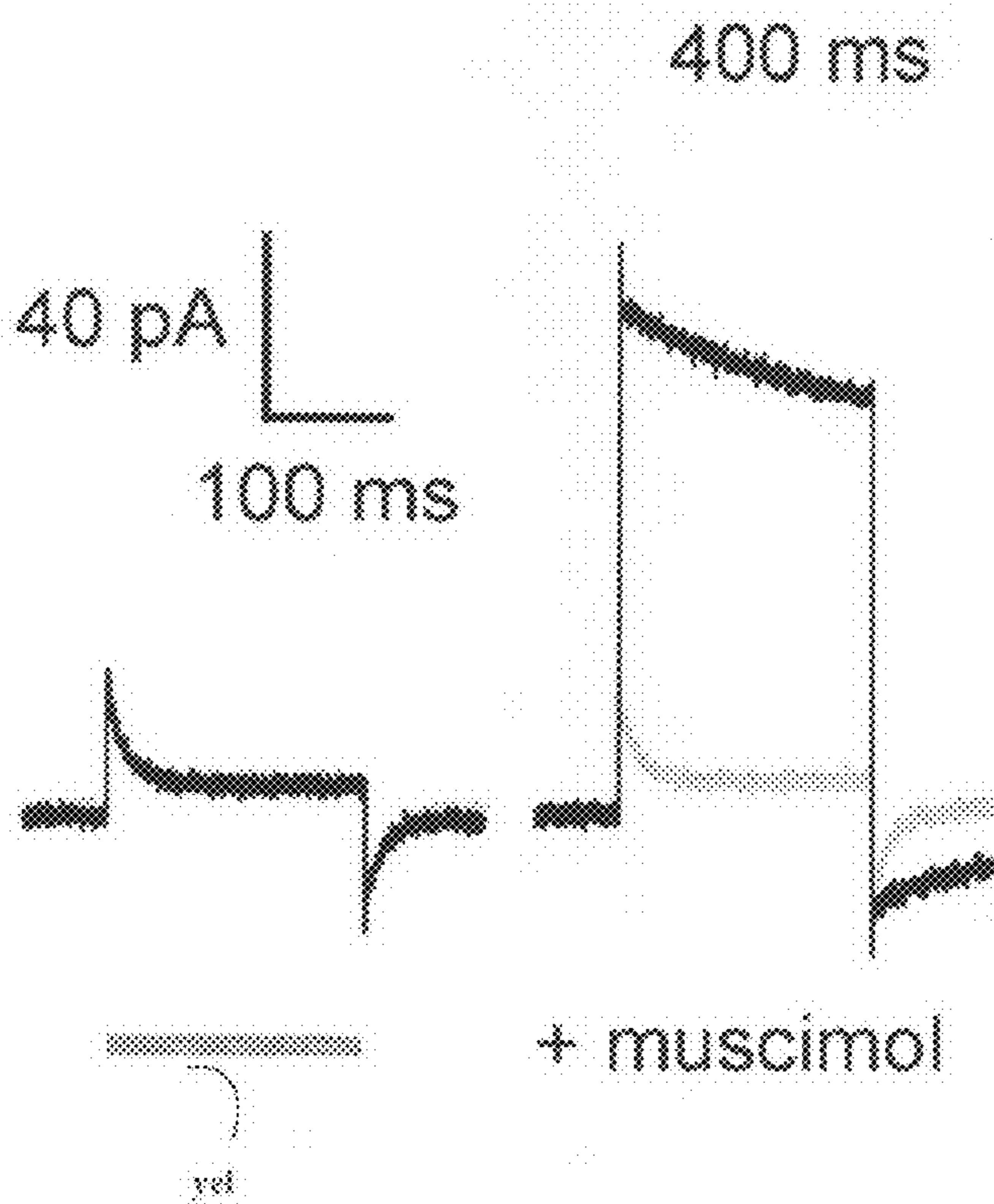


**FIG. 3**

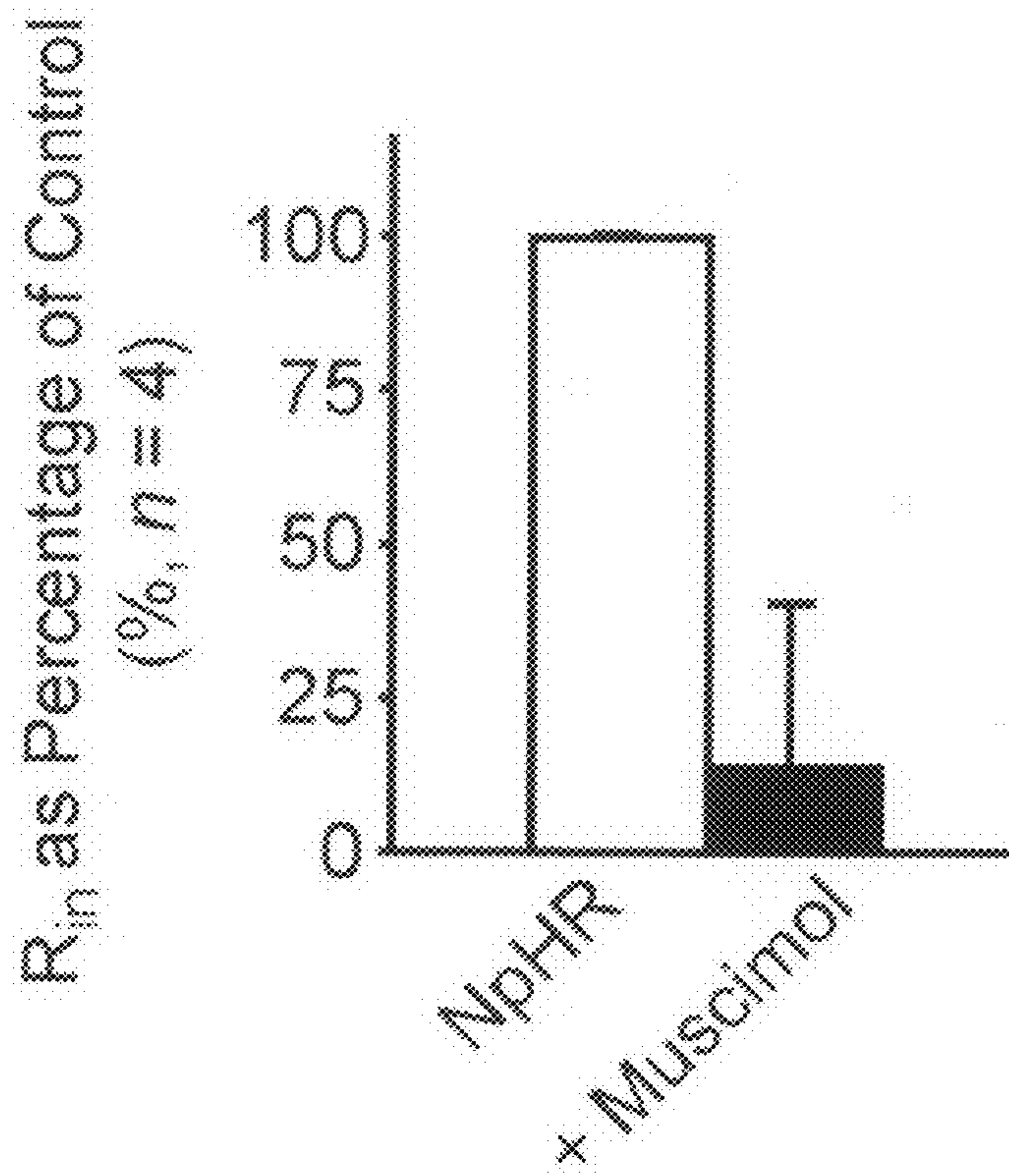


**FIG. 3**

**e**



**f**



**FIG. 3**

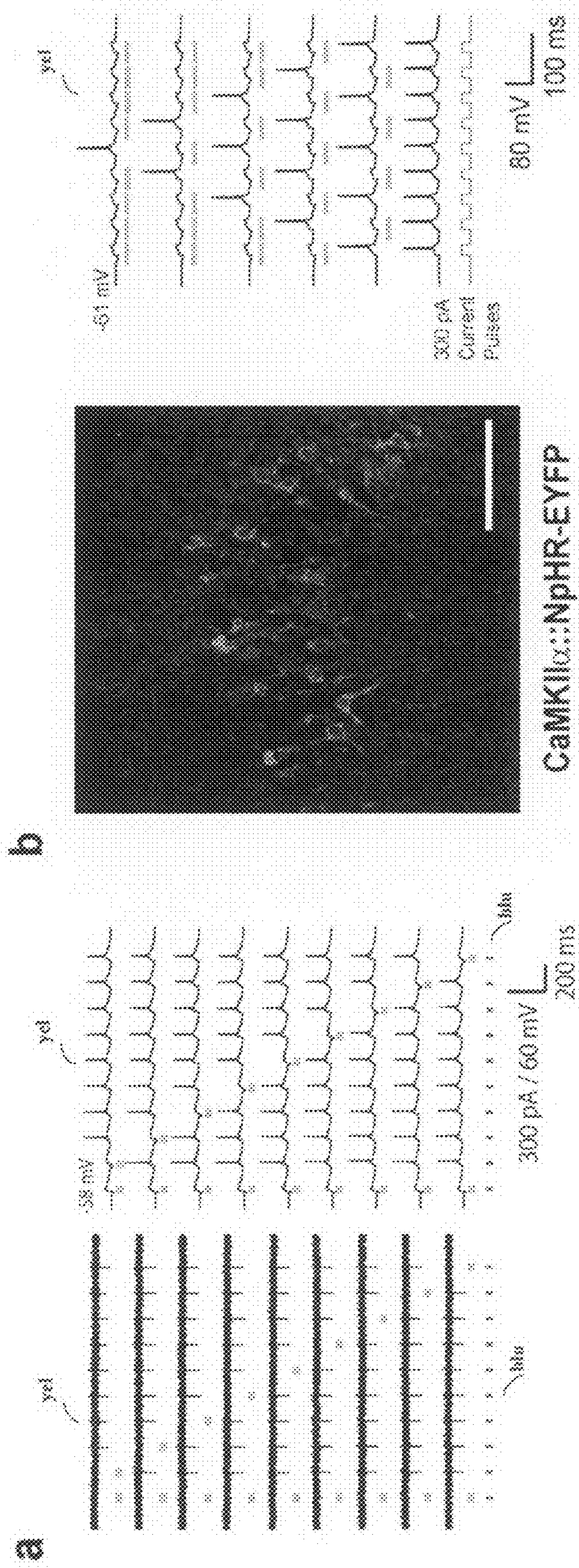


FIG. 4

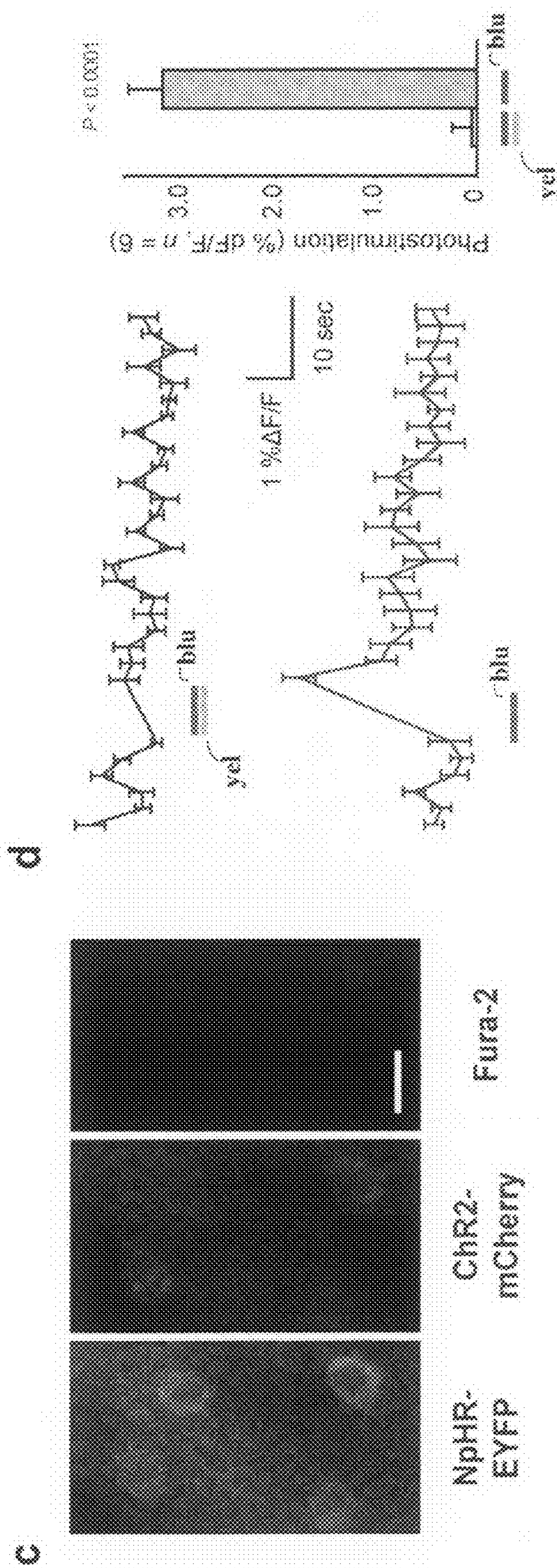


FIG. 4

f

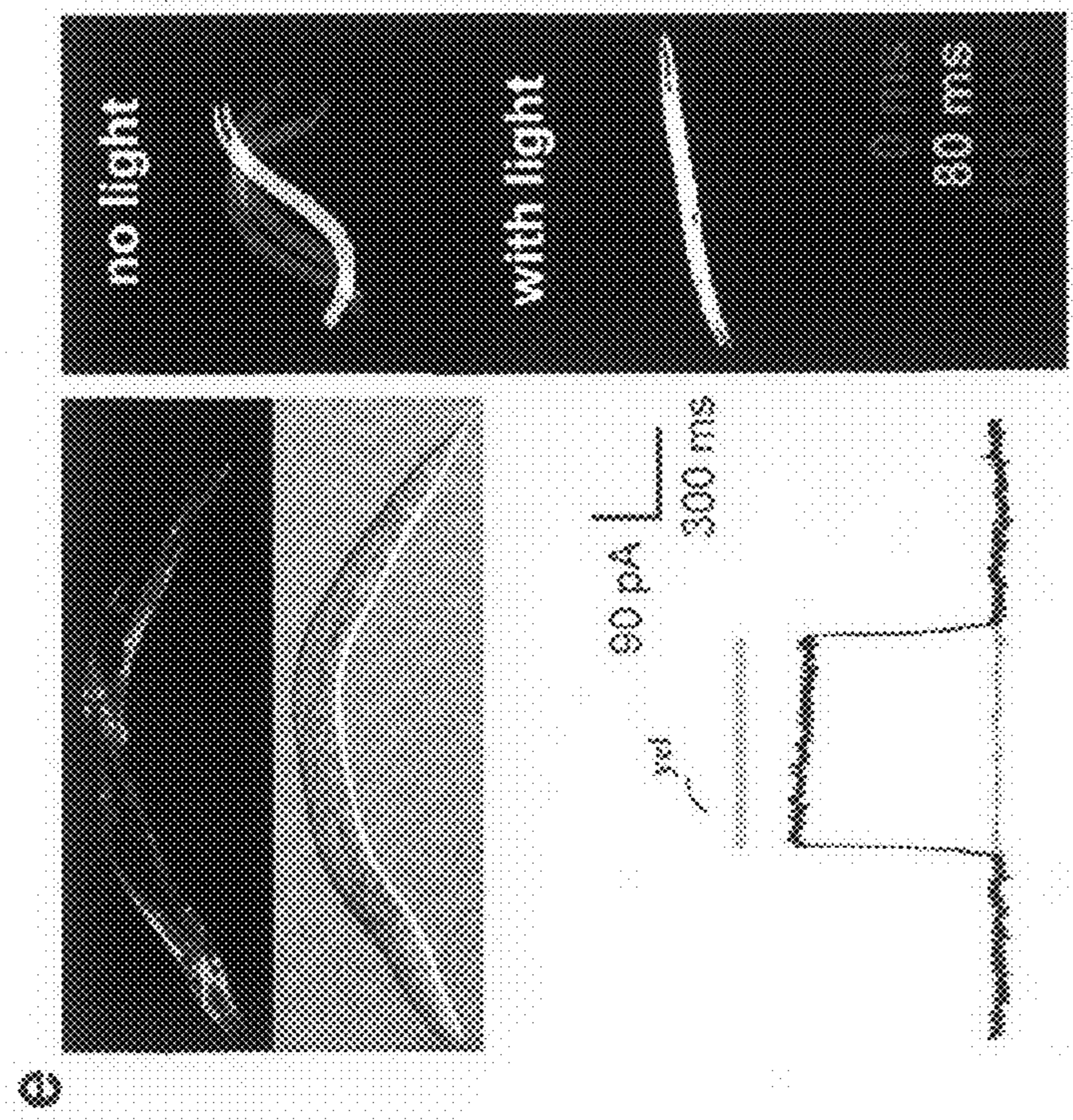
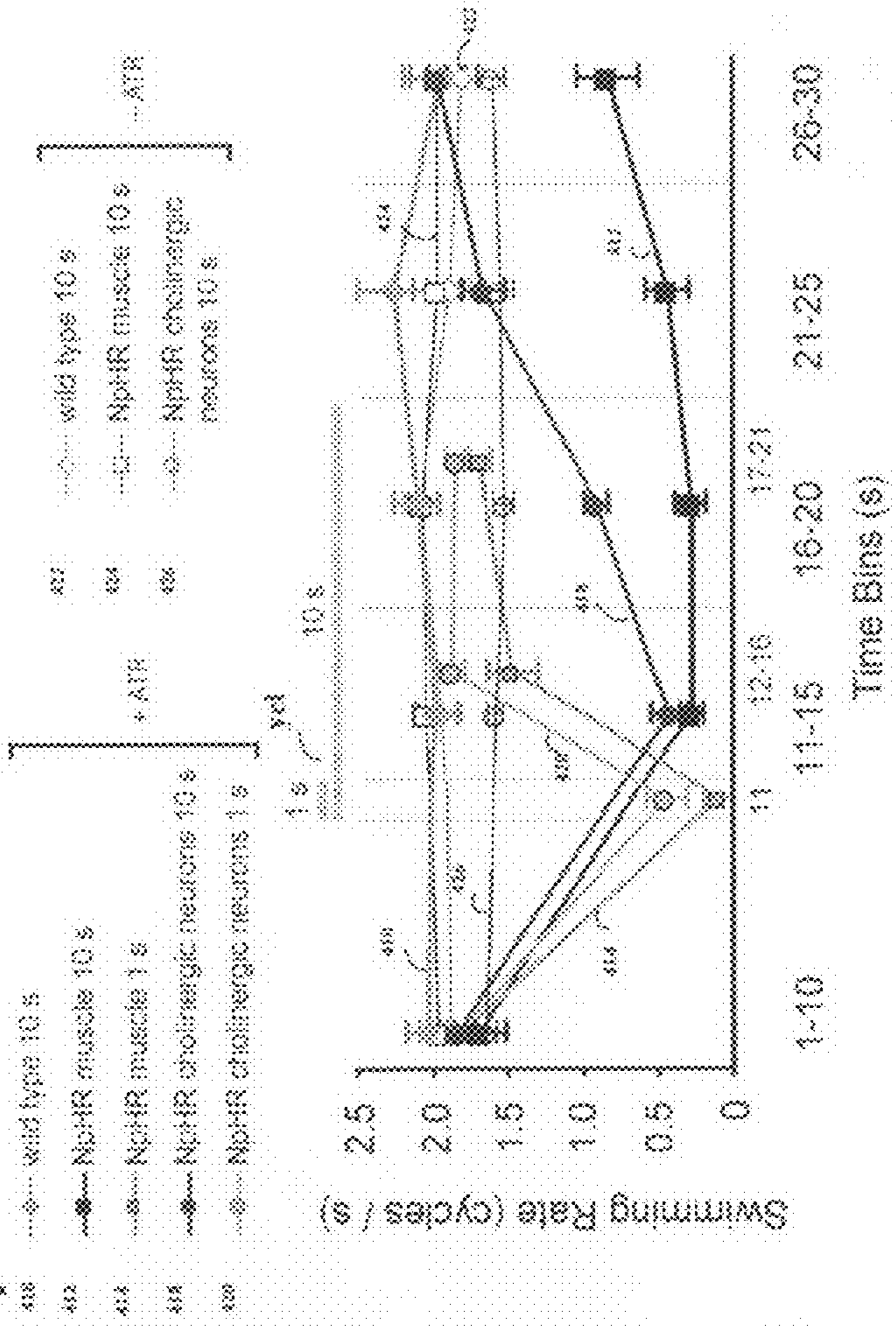


FIG. 4





**FIG. 5**

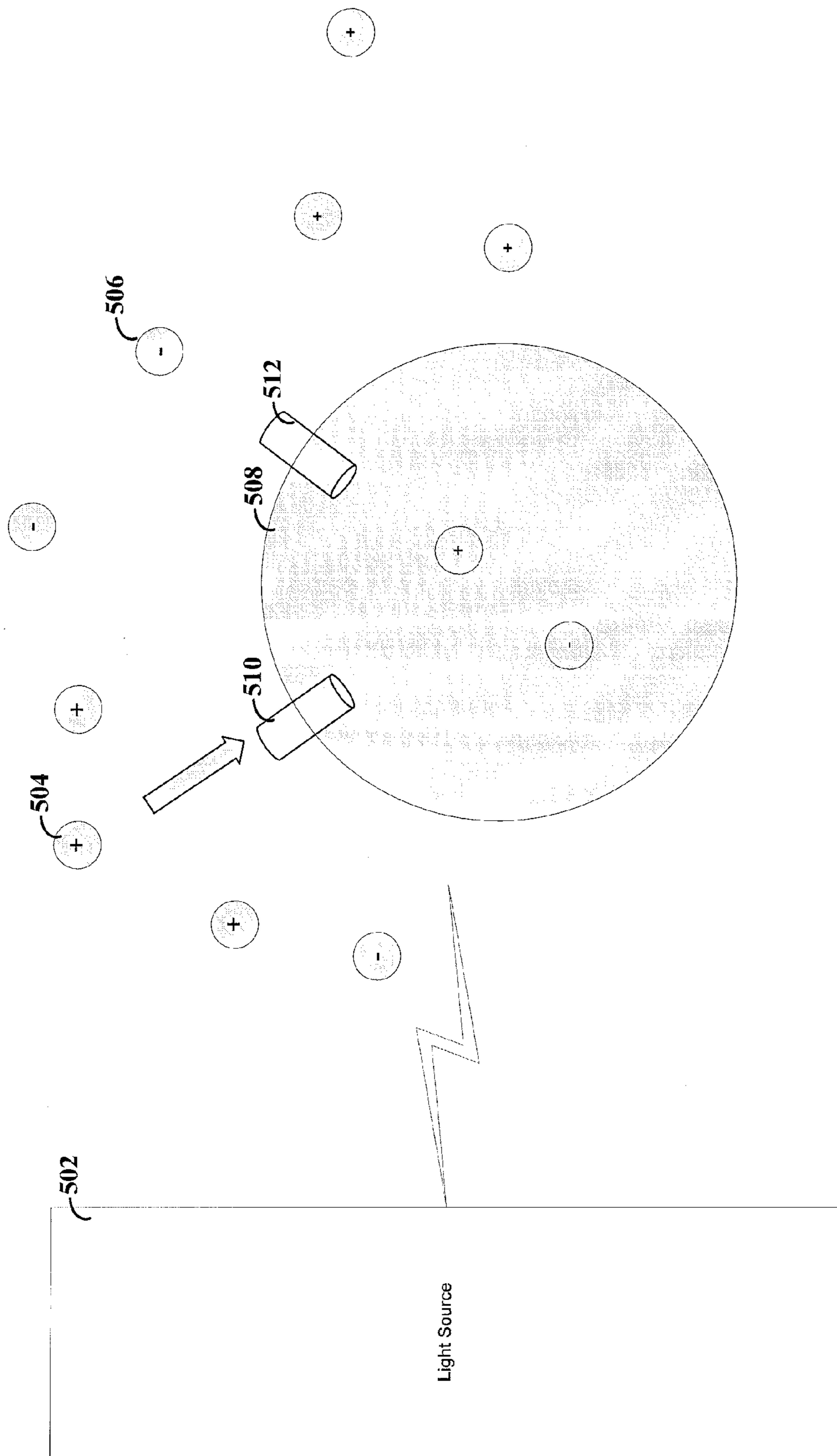
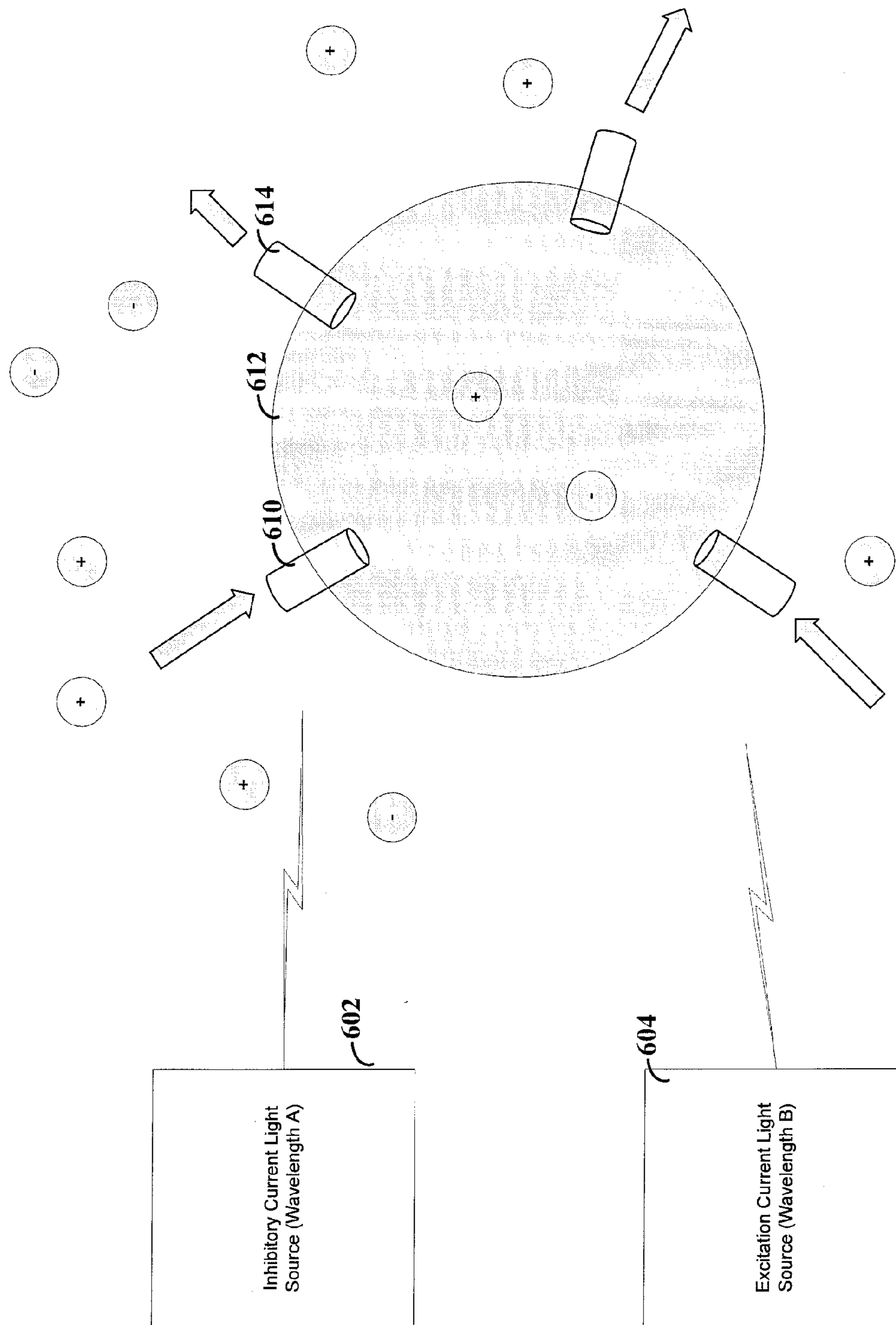
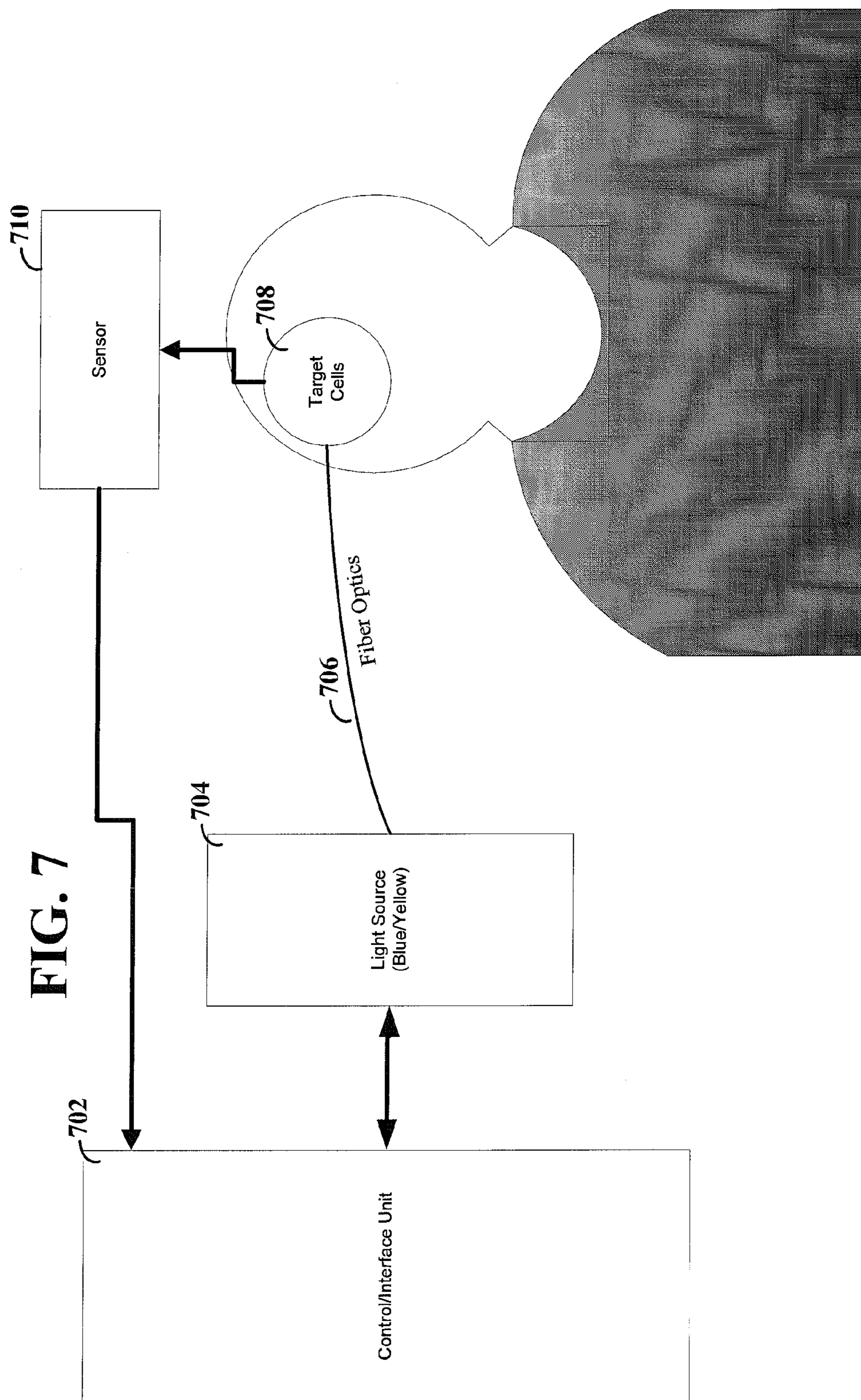
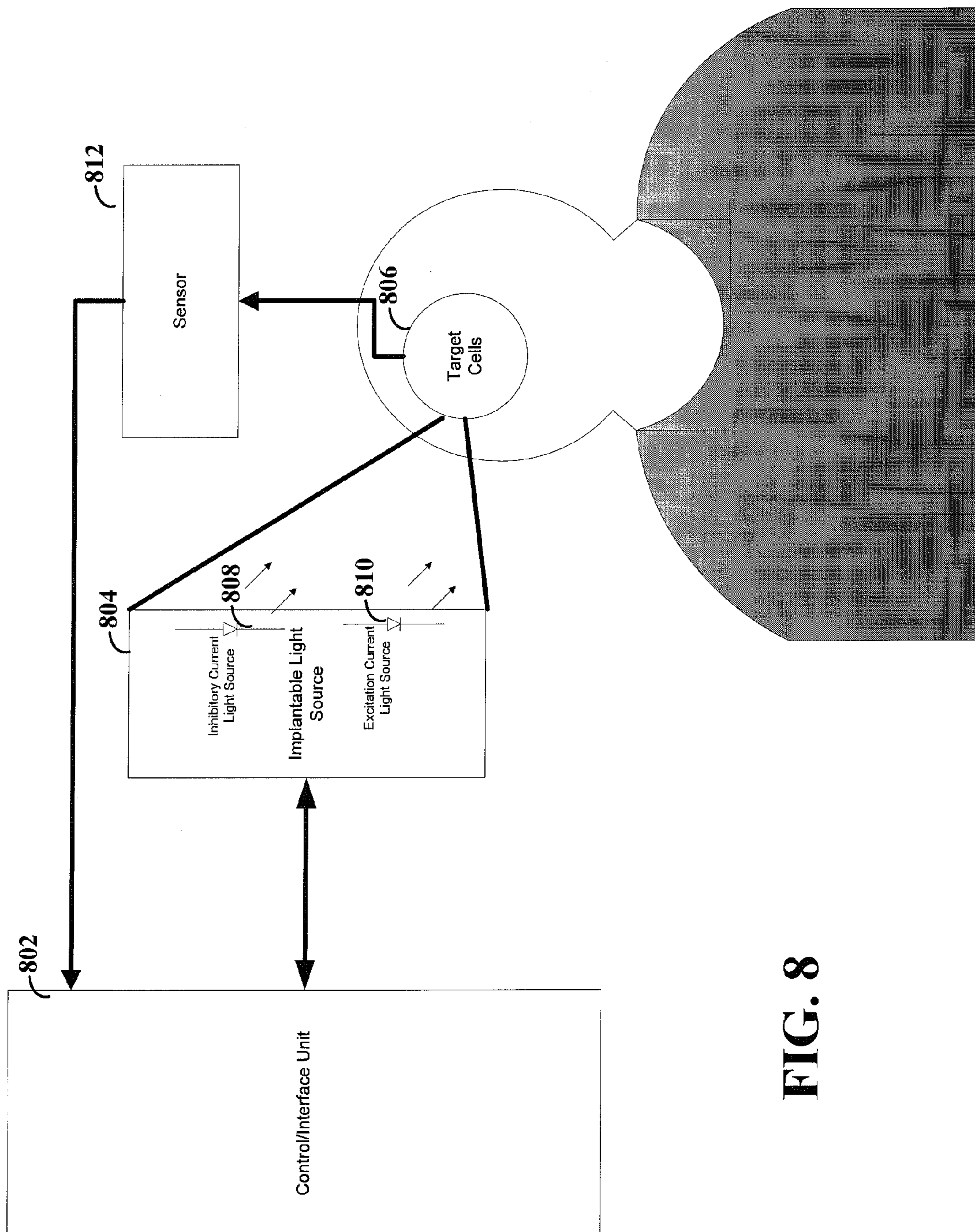


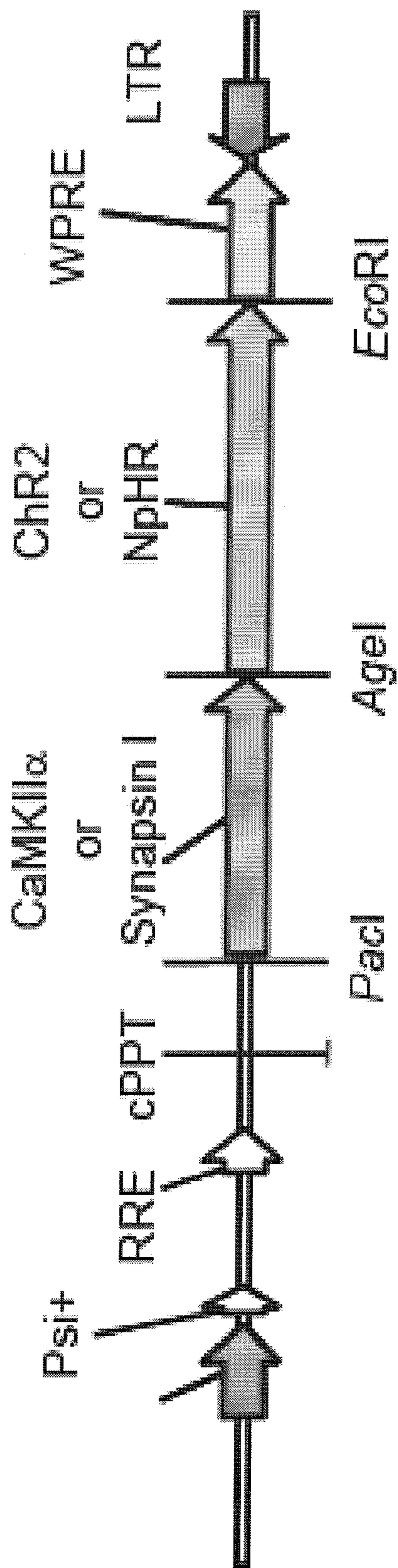
FIG. 6







**FIG. 8**



**FIG. 9**

**SYSTEMS, METHODS AND COMPOSITIONS  
FOR OPTICAL STIMULATION OF TARGET  
CELLS**

RELATED PATENT DOCUMENTS

**[0001]** This patent document claims benefit under 35 U.S. § 119(e) of U.S. Provisional Application Ser. No. 60/904,303 filed on Mar. 1, 2007 (STFD.165P1), this patent document is incorporated by reference in its entirety.

FIELD OF THE INVENTION

**[0002]** The present invention relates generally to systems and approaches for stimulating target cells, and more particularly to using optics to stimulate the target cells.

BACKGROUND

**[0003]** The stimulation of various cells of the body has been used to produce a number of beneficial effects. One method of stimulation involves the use of electrodes to introduce an externally generated signal into cells. One problem faced by electrode-based brain stimulation techniques is the distributed nature of neurons responsible for a given mental process. Conversely, different types of neurons reside close to one another such that only certain cells in a given region of the brain are activated while performing a specific task. Alternatively stated, not only do heterogeneous nerve tracts move in parallel through tight spatial confines, but the cell bodies themselves may exist in mixed, sparsely embedded configurations. This distributed manner of processing seems to defy the best attempts to understand canonical order within the central nervous system (CNS), and makes neuromodulation a difficult therapeutic endeavor. This architecture of the brain poses a problem for electrode-based stimulation because electrodes are relatively indiscriminate with regards to the underlying physiology of the neurons that they stimulate. Instead, physical proximity of the electrode poles to the neuron is often the single largest determining factor as to which neurons will be stimulated. Accordingly, it is generally not feasible to absolutely restrict stimulation to a single class of neuron using electrodes.

**[0004]** Another issue with the use of electrodes for stimulation is that because electrode placement dictates which neurons will be stimulated, mechanical stability is frequently inadequate, and results in lead migration of the electrodes from the targeted area. Moreover, after a period of time within the body, electrode leads frequently become encapsulated with glial cells, raising the effective electrical resistance of the electrodes, and hence the electrical power delivery required to reach targeted cells. Compensatory increases in voltage, frequency or pulse width, however, may spread the electrical current and increase the unintended stimulation of additional cells.

**[0005]** Another method of stimulus uses photosensitive bio-molecular structures to stimulate target cells in response to light. For instance, light activated proteins can be used to control the flow of ions through cell membranes. By facilitating or inhibiting the flow of positive or negative ions through cell membranes, the cell can be briefly depolarized, depolarized and maintained in that state, or hyperpolarized. Neurons are an example of a type of cell that uses the electrical currents created by depolarization to generate communication signals (i.e., nerve impulses). Other electrically excitable cells include skeletal muscle, cardiac muscle, and

endocrine cells. Neurons use rapid depolarization to transmit signals throughout the body and for various purposes, such as motor control (e.g., muscle contractions), sensory responses (e.g., touch, hearing, and other senses) and computational functions (e.g., brain functions). Thus, the control of the depolarization of cells can be beneficial for a number of different purposes, including (but not limited to) psychological therapy, muscle control and sensory functions.

SUMMARY

**[0006]** The claimed invention is directed to photosensitive bio-molecular structures and related methods. The present invention is exemplified in a number of implementations and applications, some of which are summarized below.

**[0007]** According to one example embodiment of the present invention, an implantable arrangement is implemented having a light-generation device for generating light. The arrangement also has a biological portion that modifies target cells for stimulation in response to light generated by the light-generation means in vivo.

**[0008]** According to another example embodiment of the present invention, target cells are stimulated using an implantable arrangement. The arrangement includes an electrical light-generation means for generating light and a biological portion. The biological portion has a photosensitive bio-molecular arrangement that responds to the generated light by stimulating target cells in vivo. Stimulation may be manifest as either up-regulation, or down-regulation of activity at the target.

**[0009]** According to another example embodiment of the present invention, an implantable device delivers gene transfer vector, such as a virus, which induces expression of photosensitive bio-molecular membrane proteins. The device has a light generator, responsive to (for example, charged by or triggered by) an external signal, to generate light and a biological arrangement that includes the photosensitive bio-molecular protein that responds to the generated light by interacting with target cells in vivo. In this manner, the electronic portions of the device may be used to optically stimulate target cells. Stimulation may be manifested as either upregulation (e.g., increased neuronal firing activity), or downregulation (e.g., neuronal hyperpolarization, or alternatively, chronic depolarization) of activity at the target.

**[0010]** According to another example embodiment of the present invention, a method is implemented for stimulating target cells using photosensitive proteins that bind with the target cells. The method includes a step of implanting the photosensitive proteins and a light generating device near the target cells. The light generating device is activated and the photosensitive protein stimulates the target cells in response to the generated light.

**[0011]** Applications include those associated with any population of electrically-excitable cells, including neurons, skeletal, cardiac, and smooth muscle cells, and insulin-secreting pancreatic beta cells. Major diseases with altered excitation-effector coupling include heart failure, muscular dystrophies, diabetes, pain, cerebral palsy, paralysis, depression, and schizophrenia. Accordingly, the present invention has utility in the treatment of a wide spectrum of medical conditions, from Parkinson's disease and brain injuries to cardiac dysrhythmias, to diabetes, and muscle spasm.

**[0012]** According to other example embodiments of the present invention, methods for generating an inhibitory neuron-current flow involve, in a neuron, engineering a protein

that responds to light by producing an inhibitory current to dissuade depolarization of the neuron. In one such method, the protein is halorhodopsin-based and in another method the protein is an inhibitory protein that uses an endogenous cofactor.

**[0013]** According to another example embodiment of the present invention, a method for controlling action potential of a neuron involves the following steps: engineering a first light responsive protein in the neuron; producing, in response to light, an inhibitory current in the neuron that is generated from the first light responsive protein; engineering a second light responsive protein in the neuron; and producing, in response to light, an excitation current in the neuron from the second light responsive protein.

**[0014]** In another method for controlling a voltage level across a cell membrane of a cell, the method comprises: engineering a first light responsive protein in the cell; measuring the voltage level across the cell membrane; and producing, in response to light of a first wavelength and using the first light responsive protein, a current across the cell membrane that is responsive to the measured voltage level.

**[0015]** According to another example embodiment of the present invention, a method for generating an inhibitory-current flow in neurons is implemented. The method includes in a neuron, engineering an inhibitory protein that responds to light by producing an inhibitory current to dissuade depolarization of the neuron, wherein the inhibitory protein does not have the sequence as set forth in GenBank accession number EF474018 and uses an endogenous cofactor to produce the inhibitory current.

**[0016]** According to another example embodiment of the present invention, a method for generating an inhibitory-current flow in neurons is implemented. The method includes in a neuron, engineering a protein that responds to light by producing an inhibitory current to dissuade depolarization of the neuron, wherein the protein uses an endogenous cofactor and results in a toxicity of the engineered neuron that is less than about 75%.

**[0017]** According to another example embodiment of the present invention, a method for controlling action potential of a neuron is implemented. A first light responsive protein is engineered in the neuron. The first light responsive protein does not have the sequence as set forth in GenBank accession number EF474018 and uses an endogenous cofactor to produce the inhibitory current. In response to light, an inhibitory current is produced in the neuron, the current generated from the first light responsive protein. A second light responsive protein is engineered in the neuron. In response to light, an excitation current is produced in the neuron from the second light responsive protein.

**[0018]** According to another example embodiment of the present invention, a method for controlling a voltage level across a cell membrane of a cell is implemented. A first light responsive protein is engineered in the cell. The voltage level across the cell membrane is measured. Light of a first wavelength is generated in response to the measured voltage level. In response to light of a first wavelength and using the first light responsive protein, a first current is produced across the cell membrane that.

**[0019]** According to another example embodiment of the present invention, system controls an action potential of a neuron in vivo. A delivery device introduces a light responsive protein to the neuron, wherein the light responsive protein produces an inhibitory current and is not the sequence as

set forth in GenBank accession number EF474018. A light source generates light for stimulating the light responsive protein. A control device controls the generation of light by the light source.

**[0020]** According to another example embodiment of the present invention, a method for treatment of a disorder is implemented. In a group of neurons associated with the disorder, inhibitory proteins are engineered that use an endogenous cofactor to respond to light by producing an inhibitory current to dissuade depolarization of the neurons, wherein the engineered group of neurons have a toxicity of less than about 75%. The neurons to light are exposed to light, thereby dissuading depolarization of the neurons.

**[0021]** According to an example embodiment of the present invention, a light-responsive opsin is provided for use in therapy. The opsin can be a NpHR-based molecule for use in therapy wherein the molecule is capable of responding to light by producing an inhibitory current to dissuade depolarization of a neuron and wherein the protein/molecule is capable of using an endogenous cofactor to produce the inhibitory current and manifests a toxicity level that is less than 75%, at a high expression level.

**[0022]** According to an example embodiment of the present invention, a light-responsive opsin is used in treating neurological diseases. The opsin can include a nucleic acid molecule comprising a nucleotide sequence encoding a NpHR based protein for use in the treatment of CNS disorders wherein said protein is capable of responding to light by producing an inhibitory current to dissuade depolarization of a neuron using an endogenous cofactor to produce the inhibitory current and manifests a toxicity level that is less than 50%, at a high expression level.

**[0023]** According to another example embodiment, a light-responsive opsin is used in the manufacture of a medicament for the treatment of neurological diseases. For example, an NpHR-based protein in the manufacture of a medicament for the treatment of CNS disorders wherein the said protein is capable of responding to light by producing an inhibitory current to dissuade depolarization of a neuron and is capable of using an endogenous cofactor to produce the inhibitory current and manifests a toxicity level that is less than 75%, at a high expression level.

**[0024]** According to another example embodiment, kit is provided for administering treatment. The kit includes, for example a product containing a first light-responsive opsin and a second-light responsive opsin as a combined preparation for simultaneous, separate or sequential use in the treatment of neurological diseases.

**[0025]** According to another example embodiment, a transgenic animal is produced with a light-responsive opsin expressed in one or more cells.

**[0026]** According to another example embodiment, cells are modified, in a live animal, using light-responsive opsins. The animal is sacrificed and the modified cells are removed for study.

**[0027]** Other aspects and embodiments are directed to systems, methods, kits, compositions of matter and molecules for ion pumps or for controlling inhibitory currents in a cell (e.g., in in vivo and in vitro environments).

**[0028]** The above summary of the present invention is not intended to describe each illustrated embodiment or every

implementation of the present invention. The figures and detailed description that follow more particularly exemplify these embodiments.

#### BRIEF DESCRIPTION OF THE DRAWINGS

[0029] The invention may be more completely understood in consideration of the detailed description of various embodiments of the invention that follows in connection with the accompanying drawings, in which:

[0030] FIGS. 1A, 1B, 1C, 1D, 1E, 1F, 1G, 1H, 1I, 1J, 1K, 1L, 1M, 1N and 1O show experimental results that are consistent with an example embodiment of the present invention;

[0031] FIGS. 2A, 2B, 2C, 2D, 2E and 2F show experimental results that are consistent with an example embodiment of the present invention;

[0032] FIGS. 3A, 3B, 3C, 3D, 3E and 3F, show experimental results that are consistent with an example embodiment of the present invention;

[0033] FIGS. 4A, 4B, 4C, 4D, 4E, 4F, 4G and 4H, show experimental results that are consistent with an example embodiment of the present invention;

[0034] FIG. 5 shows a light source and modified cell, according to an example embodiment of the present invention;

[0035] FIG. 6 depicts an arrangement with multiple light sources, according to an example embodiment of the present invention;

[0036] FIG. 7 shows a system for controlling electrical properties of one or more cells in vivo, according to an example embodiment of the present invention;

[0037] FIG. 8 shows a system for controlling electrical properties of one or more cells in vivo, according to an example embodiment of the present invention, and

[0038] FIG. 9 shows Lentiviral vector construction, according to an example embodiment of the present invention.

[0039] While the invention is amenable to various modifications and alternative forms, specifics thereof have been shown by way of example in the drawings and will be described in detail. It should be understood, however, that the intention is not to limit the invention to the particular embodiments described. On the contrary, the intention is to cover all modifications, equivalents, and alternatives falling within the spirit and scope of the invention.

#### DETAILED DESCRIPTION

[0040] The present invention is believed to be useful for facilitating practical application of a variety of photosensitive bio-molecular structures, and the invention has been found to be particularly suited for use in arrangements and methods dealing with cellular membrane voltage control and stimulation. While the present invention is not necessarily limited to such applications, various aspects of the invention may be appreciated through a discussion of various examples using this context.

[0041] Consistent with one example embodiment of the present invention, a light-responsive protein/molecule is engineered in a cell. The protein affects a flow of ions across the cell membrane in response to light. This change in ion flow creates a corresponding change in the electrical properties of the cells including, for example, the voltage and current flow across the cell membrane. In one instance, the protein functions in vivo using an endogenous cofactor to modify ion flow across the cell membrane. In another

instance, the protein changes the voltage across the cell membrane so as to dissuade action potential firing in the cell. In yet another instance, the protein is capable of changing the electrical properties of the cell within several milliseconds of the light being introduced. For details on delivery of such proteins, reference may be made to U.S. patent application Ser. No. 11/459,636 filed on Jul. 24, 2006 and entitled "Light-Activated Cation Channel and Uses Thereof", which is fully incorporated herein by reference.

[0042] Consistent with a more specific example embodiment of the present invention a protein, NpHR, from *Natronomonas pharaonis* is used for temporally-precise optical inhibition of neural activity. NpHR allows for selective inhibition of single action potentials within rapid spike trains and sustained blockade of spiking over many minutes. The action spectrum of NpHR is strongly red-shifted relative to ChannelRhodopsin-2 (ChR2) (derived from *Chlamydomonas reinhardtii*) but operates at similar light power, and NpHR functions in mammals without exogenous cofactors. In one instance, both NpHR and ChR2 can be expressed in the target cells. Likewise, NpHR and ChR2 can be targeted to *C. elegans* muscle and cholinergic motoneurons to control locomotion bidirectionally. In this regard, NpHR and ChR2 form an optogenetic system for multimodal, high-speed, genetically-targeted, all-optical interrogation of living neural circuits.

[0043] Certain aspects of the present invention are based on the identification and development of an archaeal light-driven chloride pump, such as halorhodopsin (NpHR), from *Natronomonas pharaonis*, for temporally-precise optical inhibition of neural activity. The pump allows both knockout of single action potentials within rapid spike trains and sustained blockade of spiking over many minutes, and it operates at similar light power compared to ChR2 but with a strongly red-shifted action spectrum. The NpHR pump also functions in mammals without exogenous cofactors.

[0044] According to other example embodiments of the present invention, methods for generating an inhibitory neuron-current flow involve, in a neuron, engineering a protein that responds to light by producing an inhibitory current to dissuade depolarization of the neuron. In one such method, the protein is halorhodopsin-based and in another method the protein is an inhibitory protein that uses an endogenous cofactor.

[0045] In another example embodiment, a method for controlling action potential of a neuron involves the following steps: engineering a first light responsive protein in the neuron; producing, in response to light, an inhibitory current in the neuron and from the first light responsive protein; engineering a second light responsive protein in the neuron; and producing, in response to light, an excitation current in the neuron from the second light responsive protein.

[0046] Another embodiment involves method for controlling a voltage level across a cell membrane of a cell, the method includes: engineering a first light responsive protein in the cell; measuring the voltage level across the cell membrane; and producing, in response to light of a first wavelength and using the first light responsive protein, a current across the cell membrane that is responsive to the measured voltage level.

[0047] Another aspect of the present invention is directed to a system for controlling an action potential of a neuron in vivo. The system includes a delivery device, a light source, and a control device. The delivery device introduces a light



responsive protein to the neuron, with the light responsive protein producing an inhibitory current. The light source generates light for stimulating the light responsive protein, and the control device controls the generation of light by the light source.

**[0048]** In more detailed embodiments, such a system is further adapted such that the delivery device introduces the light responsive protein by one of transfection, transduction and microinjection, and/or such that the light source introduces light to the neuron via one of an implantable light generator and fiber-optics.

**[0049]** Another aspect of the present invention is directed to a method for treatment of a disorder. The method targets a group of neurons associated with the disorder; and in this group, the method includes engineering an inhibitory protein that uses an endogenous cofactor to respond to light by producing an inhibitory current to dissuade depolarization of the neurons, and exposing the neurons to light, thereby dissuading depolarization of the neurons.

**[0050]** According to yet another aspect of the present invention is directed to identifying and developing an archaeal light-driven chloride pump, such as halorhodopsin (NpHR), from *Natronomonas pharaonis*, for temporally-precise optical inhibition of neural activity. The pump allows both knockout of single action potentials within rapid spike trains and sustained blockade of spiking over many minutes, and it operates at similar light power compared to ChR2 but with a strongly red-shifted action spectrum. The NpHR pump also functions in mammals without exogenous cofactors.

**[0051]** More detailed embodiments expand on such techniques. For instance, another aspect of the present invention co-expresses NpHR and ChR2 in the species (e.g., a mouse and *C. elegans*). Also, NpHR and ChR2 are integrated with calcium imaging in acute mammalian brain slices for bidirectional optical modulation and readout of neural activity. Likewise, NpHR and ChR2 can be targeted to *C. elegans* muscle and cholinergic motoneurons to control locomotion bidirectionally. Together NpHR and ChR2 can be used as a complete and complementary opto-genetic system for multimodal, high-speed, genetically-targeted, all-optical interrogation of living neural circuits.

**[0052]** In addition to NpHR and ChR2, there are a number of channelrhodopsins, halorhodopsins, and microbial opsins that can be engineered to optically regulate ion flux or second messengers within cells. Various embodiments of the invention include codon-optimized, mutated, truncated, fusion proteins, targeted versions, or otherwise modified versions of such ion optical regulators. Thus, ChR2 and NpHR (e.g., GenBank accession number is EF474018 for the 'mammalianized' NpHR sequence and EF474017 for the 'mammalianized' ChR2(1-315) sequence) are used as representative of a number of different embodiments. Discussions specifically identifying ChR2 and NpHR are not meant to limit the invention to such specific examples of optical regulators. For further details regarding the above mentioned sequences reference can be made to "Multimodal fast optical interrogation of neural circuitry" by Feng Zhang, et al, Nature (Apr. 5, 2007) Vol. 446: 633-639, which is fully incorporated herein by reference.

**[0053]** Consistent with an example embodiment of the present invention, a method is implemented for stimulating target cells in vivo using gene transfer vectors (for example,

viruses) capable of inducing photosensitive ion channel growth (for example, ChR2 ion channels). The vectors can be implanted in the body.

**[0054]** Consistent with a particular embodiment of the present invention, a protein is introduced to one or more target cells. When introduced into a cell, the protein changes the potential of the cell in response to light having a certain frequency. This may result in a change in resting potential that can be used to control (dissuade) action potential firing. In a specific example, the protein is a halorhodopsin that acts as a membrane pump for transferring charge across the cell membrane in response to light. Membrane pumps are energy transducers which use electromagnetic or chemical bond energy for translocation of specific ions across the membrane. For further information regarding halorhodopsin membrane pumps reference can be made to "Halorhodopsin Is a Light-driven Chloride Pump" by Brigitte Schobert, et al, The Journal of Biological Chemistry Vol. 257, No. 17. Sep. 10, 1982, pp. 10306-10313, which is fully incorporated herein by reference.

**[0055]** The protein dissuades firing of the action potential by moving the potential of the cell away from the action potential trigger level for the cell. In many neurons, this means that the protein increases the negative voltage seen across the cell membrane. In a specific instance, the protein acts as a chloride ion pump that actively transfers negatively charged chloride ions into the cell. In this manner, the protein generates an inhibitory current across the cell membrane. More specifically, the protein responds to light by lowering the voltage across the cell thereby decreasing the probability that an action potential or depolarization will occur.

**[0056]** As used herein, stimulation of a target cell is generally used to describe modification of properties of the cell. For instance, the stimulus of a target cell may result in a change in the properties of the cell membrane that can lead to the depolarization or polarization of the target cell. In a particular instance, the target cell is a neuron and the stimulus affects the transmission of impulses by facilitating or inhibiting the generation of impulses by the neuron.

**[0057]** As discussed above, one embodiment of the present invention involves the use of an optically responsive ion-pump that is expressed in a cell. In a particular instance, the cell is either a neural cell or a stem cell. A specific embodiment involves in vivo animal cells expressing the ion-pump. Certain aspects of the present invention are based on the identification and development of an archaeal light-driven chloride pump, such as halorhodopsin (NpHR), from *Natronomonas pharaonis*, for temporally-precise optical inhibition of neural activity. The pump allows both knockout of single action potentials within rapid spike trains and sustained blockade of spiking over many minutes, and it operates at similar light power compared to ChR2 but with a strongly red-shifted action spectrum. The NpHR pump also functions in mammals without exogenous cofactors.

**[0058]** According to an example embodiment of the present invention, an optically responsive ion-pump and/or channel is expressed in one or more stem cells, progenitor cells, or progeny of stem or progenitor cells. Optical stimulation is used to activate expressed pumps/channels. The activation can be used to control the ion concentrations (e.g., chloride, calcium, sodium, and potassium) in the cells. This can be particularly useful for affecting the survival, proliferation, differentiation, de-differentiation, or lack of differentiation in

the cells. Thus, optical stimulus is implemented to provide control over the (maturation) of stem or progenitor cells.

**[0059]** In a particular embodiment, optically-controlled stimulus patterns are applied to the stem or progenitor cells over a period of hours or days. For further details regarding the effects of membrane potentials and ion concentrations on such cells reference can be made to “Excitation-Neurogenesis Coupling in Adult Neural Stem/Progenitor Cells” by Karl Deisseroth, et al, *Neuron* (May 27, 2004) *Neuron*, Vol. 42, 535-552 and to U.S. Patent Publication No. 20050267011 (U.S. patent application Ser. No. 11/134,720) entitled “Coupling of Excitation and Neurogenesis in Neural Stem/Progenitor Cells” to Deisseroth et al and filed on May 19, 2005, which are each fully incorporated herein by reference.

**[0060]** In a particular embodiment, a method of driving differentiation in cells is implemented. The cells are caused to express light-activated NpHR-based protein. The cells are exposed to light to activate the NpHR-based protein. The activation drives differentiation of the exposed cell or the progeny of the exposed cell.

**[0061]** In another embodiment, the cells comprise stem cells.

**[0062]** Two exemplary ion pumps originate from two strains of archaea, *Halobacterium salinarum* (HsHR) and *Natronomonas pharaonis* (NpHR). Illumination of HsHR or NpHR-expressing oocytes leads to rapid outward currents. Both HsHR and NpHR have excitation maxima near 580 nm as shown in FIG. 1A. Specifically, FIG. 1A shows the action spectrum of NpHR when measured in *Xenopus oocytes* using a Xenon short arc lamp and narrowbandwidth 20 nm filters, which is red-shifted from the known ChR2 maximum of ~460 nm. This spectral separation allows for ChR2 and an HR to be activated independently or in synchrony to effect bidirectional optical modulation of membrane potential.

**[0063]** In an experimental test, HsHR was found to have a lower extracellular Cl<sup>-</sup> affinity than NpHR (K<sub>m,NpHR</sub>=16 mM in FIG. 1B, K<sub>m,HsHR</sub>=32 mM) and measured currents displayed rapid rundown at low extracellular [Cl<sup>-</sup>] that did not fully recover in darkness. The influence of cytoplasmic [Cl<sup>-</sup>] on HR pump currents was studied using excised giant patches. HR pump currents were not influenced by cytoplasmic [Cl<sup>-</sup>] (from 0 to 124 mM), indicating a very low affinity for Cl<sup>-</sup> on the cytoplasmic side where Cl<sup>-</sup> ions are released, as expected since HR-mediated chloride pumping can achieve molar concentrations of cytoplasmic Cl<sup>-</sup>. The pump current exhibits more or less linear voltage dependence, and Cl<sup>-</sup> current is robust for both HRs across all physiological voltage regimes.

**[0064]** In one instance, a mammalian codon-optimized NpHR gene fused with enhanced yellow fluorescent protein (NpHR-EYFP) was introduced into cultured rat hippocampal CA3/CA1 neurons using lentiviruses carrying the ubiquitous EF-1 $\alpha$  promoter (EF1  $\alpha$ ::NpHR-EYFP). Cells expressing NpHR-EYFP exhibited robust expression for weeks after infection (FIG. 1C). In voltage clamp, illumination of NpHR-EYFP cells with yellow light (bandwidth 573-613 nm via Semrock filter FF01-593/40-25; 300 W xenon lamp) induced rapid outward currents (FIG. 1D, top) with a peak level of 43.8 $\pm$ 25.9 pA and a steady-state level of 36.4 $\pm$ 24.4 pA (mean $\pm$ s.d. reported throughout this paper, n=15; FIG. 1E). The relatively small difference between the peak and steady-state currents is believed to be indicative of rare deprotonation of the NpHR Schiff base during the pump cycle<sup>24</sup>. The rise time from light onset to 50% of the peak current is consistent

across all cells (6.0 $\pm$ 1.0 ms; FIG. 1F) with rise and decay time constants of T<sub>on</sub>=6.1 $\pm$ 2.1 ms and T<sub>off</sub>=6.9 $\pm$ 2.2 ms respectively. Light-evoked responses were never seen in cells expressing EYFP alone. In current clamp, NpHR-EYFP neurons exhibited light-evoked hyperpolarization (FIG. 1D; bottom) with an average peak of 14.7 $\pm$ 6.9 mV and a steady-state of 12.1 $\pm$ 6.6 mV (FIG. 1G). The delay from light onset to 50% of hyperpolarization peak was 26.0 $\pm$ 8.6 ms (FIG. 1F) and the rise and decay time constants were T<sub>on</sub>=35.6 $\pm$ 15.1 ms and T<sub>off</sub> 40.5 $\pm$ 25.3 ms respectively. To test whether NpHR-mediated hyperpolarization could inhibit neuronal firing, current-clamped neurons were injected with a 200 pA current step for 2 s to evoke robust spike firing; concurrent light delivery abolished the evoked activity (FIG. 1H).

**[0065]** Images of NpHR-EYFP and ChR2-mCherry co-expressed in cultured hippocampal neurons were taken (FIG. 1I). NpHR function was probed using cell-attached recordings with ChR2 photostimulation to drive reliable spike trains. Indeed, whereas trains of blue light pulses (see “blu” in FIG. 1J) were able to evoke action potentials, concomitant yellow light illumination (see “yel” in FIG. 1J) abolished spike firing in both cell-attached and subsequent whole-cell recording modes (FIG. 1J). After achieving the whole-cell configuration, voltage-clamp recording showed that independent exposure to yellow or blue light led to outward or inward photocurrents respectively (FIG. 1K), further confirming that ChR2 and NpHR can be combined to achieve bidirectional, independently addressable modulation of membrane potential in the same neuron. Further confirming that NpHR inhibitory function does not require a specific pipette chloride concentration under these recording conditions, it was found that NpHR-mediated inhibition is robust across a range of relevant whole-cell pipette chloride concentrations (4-25 mM) and physiologically negative resting potentials, as expected from the fact that NpHR is designed to deliver chloride ions to molar levels in the archaeal intracellular milieu.

**[0066]** Extensive controls were conducted to test whether heterologous expression of NpHR in neurons would alter the membrane properties or survival of neurons. Lentiviral expression of NpHR for at least 2 weeks did not alter neuronal resting potential (-53.1 $\pm$ 6.3 mV for NpHR+ cells, -57.0 $\pm$ 4.8 mV for NpHR- cells, and -56.7 $\pm$ 5.7 mV for NpHR+ cells exposed to yellow light for 10 min followed by a delay period of 1 day; FIG. 1L, n=12 each) or membrane resistance (114.5 $\pm$ 34.1 M $\Omega$  for NpHR+ cells, 108.9 $\pm$ 20.1 M $\Omega$  for NpHR- cells, and 111.4 $\pm$ 23 M $\Omega$  for the light-exposed NpHR+ cells; FIG. 1M, n=12 each). These electrical measurements indicated that NpHR has little basal electrical activity or passive current-shunting ability and can be acceptable regarding cell health.

**[0067]** The dynamic electrical properties of neurons were tested with and without NpHR. There was no significant difference in the number of spikes evoked by 500 ms current injection of 300 pA (7.5 $\pm$ 2.8 for NpHR+ neurons, 10.7 $\pm$ 7.9 for NpHR- neurons, and 9.3 $\pm$ 5.1 for the light-exposed NpHR+ neurons; FIG. 1N).

**[0068]** To assess cell survivability, both live NpHR+ neurons (with and without light exposure) and NpHR- neurons were stained with the membrane-impermeant DNA-binding dye propidium iodide to assess cell survival. NpHR expression did not affect the percentage of neurons that took up propidium iodide (13/240 for NpHR+ cells, 7/141 for NpHR- cells, and 10/205 for the light-exposed NpHR+ cells; FIG. 1M, P>0.999 by X<sup>2</sup> test). These experiments indicated that

NpHR expression does not significantly affect the health or basal electrical properties of neurons.

**[0069]** The tunability of NpHR efficacy with different intensities of delivered light was measured using a 200 pA current step that drove reliable action potential trains. It was discovered that maximal light intensity of 21.7 mW/mm<sup>2</sup> under a 40×, 0.8 NA water-immersion objective inhibited 98.2±3.7% of the spikes.

**[0070]** Using a 200 pA current step to drive reliable action potential trains, a maximal light intensity of 21.7 mW/mm<sup>2</sup> under 40×, 0.8 NA water-immersion objective inhibited 98.2±3.7% of spikes (FIGS. 2A and 2B). Using 33% or 50% of the full light intensity inhibited 74.9±22.2% and 87.3±13.5% of spikes, respectively (FIG. 2B). FIG. 2C shows that with steady current injection, lower intensities of light were effective for a shorter period of time; the delays from light onset to the first escaped spike under 33%, 50% and 100% light intensity were 533.65±388.2 ms, 757.5±235.5 ms, and 990.5±19.1 ms, respectively. Therefore inhibition is likely to be more effective early in the light pulse, presumably due to the slight inactivation of NpHR. Except where otherwise noted, the remaining experiments were conducted with 21.7 mW/mm<sup>2</sup> yellow light delivered to the neurons.

**[0071]** Using trains of brief current pulses to generate spike trains, NpHR was tested for mediation of both long-term inhibition (to emulate lesions on the timescale of seconds to minutes) and short-term inhibition (to modify spike firing on the millisecond timescale). For long-term inhibition NpHR was tested over 10 min by injecting 300 pA current pulses at 5 Hz to drive steady action potential firing. Concurrent yellow light was delivered continuously for 10 minutes. NpHR mediated inhibition of spike trains remained effective over many minutes as shown by FIG. 2D. 99.0±1.9% of spikes were inhibited within the first two minutes while over 90% of spikes were inhibited for up to 8 minutes as shown in FIG. 2E, with n=5. The slight decrease in efficacy is likely due to accumulation of non-functional NpHRs with a deprotonated Schiff base over long periods of light exposure. While natural reprotonation of the Schiff base is slow, any non-functional NpHRs can be readily and quickly restored via brief illumination with blue light as shown by FIG. 2F.

**[0072]** NpHR activation was tested for the ability to allow the “knockout” of single action potentials. The fast photocurrent of ChR2 enables brief pulses of blue light to drive reliable action potential trains. Concurrently applied brief pulses of yellow light were used to test NpHR-mediated inhibition. FIG. 3A shows the results of an attempt to inhibit pairs of spikes in action potential trains of 5, 10, 20, and 30 Hz. Indeed, single spikes could be reliably inhibited from within longer spike trains. Several pairs of spikes within a range of inter-spike temporal delays were inhibited in an effort to define the temporal precision of NpHR. FIGS. 3A, 3B and 3C show that both closely timed and temporally separated spike pairs were able to be reliably inhibited, while sparing spikes between the targeted times (n=6). Over spike rates of 5 to 30 Hz, the closely timed spikes could be selectively inhibited with a probability of 0.95 or greater. Moreover, FIG. 3D shows that by giving trains of millisecond-scale yellow light pulses, it is straightforward to simulate barrages of IPSP-like events with precise, reliable timing and amplitudes, from 5 to 100 Hz.

**[0073]** Since NpHR is a Cl<sup>-</sup> pump and not a channel, the light-driven inhibition acts by shifting the membrane potential and will not contribute (significantly) to shunting or input

resistance changes. FIGS. 3E and 3F show that, whereas the GABAA chloride channel agonist muscimol significantly decreased neuronal input resistance, NpHR activation had no detectable effect on the input resistance.

**[0074]** Since both ChR2 and NpHR can be activated with high temporal precision using millisecond-scale blue or yellow light pulses, an experiment was implemented to test the possibility of driving both proteins in intermingled temporally precise patterns. Such ability can be useful to noninvasively activate or inhibit single identified action potentials with light in the same experiment or even in the same cell. Cell attached and whole-cell recordings in hippocampal pyramidal neurons revealed that precisely patterned trains of yellow and blue light pulses can be used to evoke and inhibit neural activity with single spike precision, and that NpHR can be used to override multiple preselected ChR2-driven spikes at identified positions in prolonged spike trains.

**[0075]** Both NpHR and ChR2 can be functionally expressed in the mammalian brain without exogenous delivery of its required cofactor all-trans-retinal (ATR), presumably due to the presence of endogenous retinoids in the mammalian brain. As an experiment, lentiviruses carrying NpHR-EYFP were delivered under the neuronal CaMKII $\alpha$  promoter into the hippocampus of the adult mouse. Neurons throughout the hippocampus exhibited stable expression of NpHR-EYFP, as indicated by a robust EYFP fluorescence.

**[0076]** NpHR-EYFP cells in acute hippocampal slices exhibited voltage clamp photocurrents similar to those observed in cultured neurons. A current clamp recording of NpHR-EYFP neurons revealed that temporally precise patterns of spike inhibition could be achieved readily as in dissociated culture. No exogenous cofactors were delivered at any point, indicating that NpHR can be functionally applied to mammalian systems in vivo.

**[0077]** In another instance, NpHR/ChR2 was combined in a system by expressing in living mammalian neural circuitry, with fura-2 calcium imaging, in an all-optical experiment. Lentiviruses carrying ChR2-mCherry under the neuron-specific CaMKII $\alpha$  promoter and NpHR-EYFP under the EF-1 $\alpha$  promoter were injected into the brain of postnatal d4 mouse pups; acute cortical slices were prepared at postnatal d10-14 and labeled with fura-2-AM. In neurons co-expressing ChR2-mCherry and NpHR-EYFP, initial simultaneous illumination with both blue and yellow light did not lead to [Ca<sup>2+</sup>] transients while subsequent pulsed blue light alone in the same neurons evoked ChR2-triggered [Ca<sup>2+</sup>] transients. This demonstrates that NpHR and ChR2 can be integrated to achieve multimodal, bidirectional control of neural activity in intact tissue. In the same imaged cells (where ChR2 stimulation led to a 3.1±0.3% increase in AF/F), the combination of NpHR and ChR2 activation resulted in a 0.0±0.2% effect on AF/F (n=6, P<0.0001). Yellow illumination alone had no detectable effect on [Ca<sup>2+</sup>]. Since not all targeted cells are necessarily affected to the same degree, this optical system could complement electrophysiology to probe successful modulation of the targeted cell population. Thus, according to one embodiment, the combination of ChR2 and NpHR with calcium imaging provides an all-optical system for interrogation of neural circuits.

**[0078]** Another set of experiments were conducted to show control of animal behavior in vivo. An in vivo experiment involved expression of NpHR-EYFP fusion protein in the body wall muscles of the nematode *Caenorhabditis elegans* using the muscle-specific myosin promoter (Pmyo-3). EYFP

fluorescence could be readily observed throughout muscle cells and membranous muscle arm extensions. As worms (unlike mammals) appear not to have sufficient levels of endogenous retinoids, transgenic animals expressing NpHR in muscle were grown in medium containing ATR. Whole-cell voltage-clamp recordings from dissected muscles indeed demonstrated light-evoked outward currents ( $265 \pm 82$  pA,  $n=9$ ). To test effects on muscle activity, swimming behavior in liquid medium was analyzed. Consistent with the photocurrents observed, photoactivation of NpHR immediately (within  $\sim 150$  ms) and essentially completely arrested swimming behavior. Transgenic animals, raised in the absence of ATR and wild type animals raised with and without ATR, were used as controls. Robust paralyzing effects of light were observed, but consistently only in transgenic animals raised in the presence of ATR.

**[0079]** When transgenic muscle-expressing animals were illuminated for 1 second, they quickly returned to their natural swimming rate after light stimulus termination. When NpHR was activated in muscle for 10 seconds, animals remained uncoordinated for prolonged periods (up to 40 seconds), before a full recovery became apparent and normal swimming commenced.

**[0080]** Another experiment involved targeting of NpHR to a specific class of genetically defined neurons *in vivo*. NpHR-ECFP was expressed in cholinergic motoneurons using the vesicular acetylcholine transporter promoter (Punc-17). When illuminated for 1 or 10 seconds, respectively, these animals also strongly reduced or essentially stopped swimming behavior. These animals, in contrast to the muscle targeted individuals, recovered to normal swimming behavior immediately, perhaps indicating more powerful Cl<sup>-</sup> homeostasis in neurons than in muscles, although in all cases full recovery was observed consistent with the lack of toxicity observed in mammalian neurons. When illuminated on solid agar substrate, transgenic animals expressing NpHR either in muscle, or in cholinergic motoneurons, exhibited rapid inhibition of movement and relaxed their bodies, resulting in overall elongation by up to 9% within  $\sim 600$  ms of illumination.

**[0081]** ChR2 and NpHR were found to be able to be driven simultaneously in *C. elegans*. With either muscle or targeted cholinergic neuron expression (using the Pmyo-3 or Punc-17 promoters, respectively), NpHR rapidly and reversibly counteracted the shortening behavior observed with ChR2 alone. These experiments demonstrate that acetylcholine release can be efficiently triggered from *C. elegans* motoneurons using ChR2, and that ChR2 and NpHR work well together in nematodes as well as mammals. In some instances, such an NpHR/ChR2 system enables rapid bidirectional control of neurons on the timescale of milliseconds, thus enabling emulation or alteration of the neural code. These fast genetically based neural spike-controlling technologies powerfully augment existing tools for interrogating neural systems. Indeed, integration of the NpHR/ChR2 neural control system with optical activity markers like fura-2, and with GFP-based morphological markers, delivers a versatile triad of technologies for watching, listening to, and controlling living neural circuitry with light.

**[0082]** Both NpHR and ChR2 can be functionally expressed and operate at high speed in the mammalian brain without necessitating cofactor addition. Moreover, NpHR and ChR2 function in behaving *C. elegans* as well after simple dietary ATR supplementation. When combined with

optical imaging or behavioral measures in intact tissue or freely moving animals, the NpHR/ChR2 system provides the capability to directly and causally link precisely defined patterns of neural activity with specific circuit behaviors.

**[0083]** The ability to use light to inhibit or activate neurons has practical applications beyond basic science investigations. The NpHR/ChR2 system may be genetically targeted to specific classes of neurons or other excitable cells involved in disease processes to enable highly precise optical therapeutic treatments. For example, in Parkinson's disease where electrode-based deep brain stimulation (DBS) can be therapeutic for symptomatic relief but also gives rise to side effects, delivery of these optogenetic tools targeted by cell type-specific promoters to distinct disease-related neuronal types may ultimately provide a more precise alternative with fewer side-effects. Whether in basic science or clinical applications, the spectral separation between the NpHR and ChR2 activation maxima allows for the first time bidirectional optical control in the same target tissue, and permits both sufficiency and necessity testing in elucidation of the roles of specific cell types in high-speed intact circuit function.

**[0084]** Oocyte microinjection and physiology were experimentally carried out using the following procedures. NpHR cRNA was generated using the T7-cap scribe kit from Ambion (Austin, Tex.). Stage V/VI oocytes were prepared. Each oocyte was injected with 30 to 50 ng cRNA, incubated for 4 to 7 days at 16 to 18° C. with 1  $\mu$ M ATR in the medium (90 mM NaCl, 2 mM KCl, 1 mM MgCl<sub>2</sub>, 1.8 mM CaCl<sub>2</sub>, 5 mM HEPES, pH 7.4/NaOH) to reconstitute functional HR. As a control uninjected oocytes were incubated in the same medium. Oocytes were recorded using two-electrode voltage-clamp (Turbo Tec-05) and illuminated with a continuous He—Ne laser (594 nm, LYHR-0600M, Laser 2000, Wessling, Germany). The maximum light intensity was 3 mW/mm<sup>2</sup> and was focused to a diameter close to the dimensions of the oocyte. In giant patch experiments from halorhodopsin-expressing oocytes a continuous He—Ne laser of 633 nm with light intensities up to 400 mW/mm<sup>2</sup> was used.

**[0085]** Lentiviral vector construction was experimentally carried out using the following procedures. Lentiviral vectors containing Synapsin I::ChR2-mCherry, CaMKII $\alpha$ ::ChR2-mCherry, and CaMKII $\alpha$ ::NpHR-EYFP were based on the FCK(1.3)GW plasmid. For the construction of these lentiviral vectors, the promoter was PCR amplified and cloned into the PacI and AgeI restriction sites (FIG. 9). The transgene ChR2-mCherry or NpHR-EYFP were PCR amplified and cloned into the AgeI and EcoRI restriction sites. The pLE-HYT vector is constructed in the same way as pLECYT3 by inserting the NpHR-EYFP gene into the AgeI and SpeI restriction sites of pLEGT.

**[0086]** For both NpHR-EYFP and ChR2-mCherry, the protein fusion was made via a NotI restriction site. The linker between the two proteins is 5'-GCGGCCGCC-3'. The start codon on the fluorescent protein was removed deliberately to avoid translation of the fluorescent protein alone. In addition to the promoter, each lentiviral vector contains the HIV-1 central polypurine tract (cPPT) and the Woodchuck Hepatitis Virus Post-transcriptional Regulatory Element (WPPE) to improve transduction efficiency.

**[0087]** Lentiviral production and transduction were experimentally carried out using the following procedures. High-titer lentiviruses were produced using a second generation lentiviral system, by cotransfection of 293FT cells (Invitro-

gen) with pCMV $\Delta$ R8.74 and pMD2.G in addition to the viral vector. The following protocol was used.

**[0088]** Day 0: Split 4 T-225 flasks (Nunc) of 95% confluent 293FT cells into one 4 layer CellFactory (Nunc). Culture using 500 mL of DMEM with 10% FBS. Incubate the plates at 37° C. overnight. The cells should reach 90% confluence in 24 hours.

**[0089]** Day 1: Perform calcium phosphate transfection; make DNA mixture containing 690  $\mu$ g of the viral vector, 690  $\mu$ g of pCMV $\Delta$ R8.74, and 460  $\mu$ g of pMD2.G. Add 5.7 mL of 2M CaCl<sub>2</sub> to the DNA mixture and bring the total volume to 23.75 mL with distilled H<sub>2</sub>O; then, quickly combine the DNA/CaCl<sub>2</sub> solution with 23.75 mL of 2 $\times$ HBS (50 mM HEPES, 1.5 mM Na<sub>2</sub>HPO<sub>4</sub>, 180 mM NaCl, pH 7.05; note that the pH is important); after quickly mixing by inverting 5 times, add the DNA/CaCl<sub>2</sub>/HBS solution to 500 mL of room-temperature DMEM with 10% FBS to make the transfection media; then, exchange the media in the CellFactory with the transfection media.

**[0090]** Day 2: 15 hours from the time of transfection, remove the transfection media from the CellFactory and wash the cells 3 times with fresh room-temperature DMEM; incubation longer than 15 hours may lead to cell death and reduced viral titer; finally, replace the media with 500 mL of fresh DMEM containing 10% FBS and incubate in a 37° C. incubator for 9 hours.

**[0091]** Day 2.5: 24 hours from the time of transfection, remove the media from the CellFactory and replace with 200 mL of serum-free media (UltraCULTURE, Cambrex) containing 5 mM Sodium Butyrate; return the CellFactory to the incubator.

**[0092]** Day 3: 40 hours from the time of transfection, collect the 200 mL of media from the CellFactory. This is the viral-containing supernatant. Centrifuge at 1000 rpm for 5 minutes to precipitate large cell debris and then filter the viral supernatant using a 0.45  $\mu$ m low-protein binding filter flask. Then, centrifuge the supernatant using a SW-28 rotor (Beckman Coulter) for 2 hours at 55,000 $\times$ g to precipitate the virus. Usually 6 centrifuge tubes are required to concentrate all of the viral supernatant. Before spinning, add 2 mL of PBS containing 20% sucrose to the bottom of the centrifuge tube to remove any remaining cell debris during centrifugation. After centrifugation, gently decant the liquid from the centrifuge tubes and re-suspend all 6 viral pellets with 100  $\mu$ L of 4° C. PBS. Then, aliquot the viral solution and store at -80° C. for future use. If desired, 10 mL of unconcentrated viral supernatant can be stored before centrifugation for in vitro use in cultured neurons. For culture applications, neurons can be transduced simply by adding 50  $\mu$ L of unconcentrated viral supernatant per 24-well plate well. Protein expression can be observed 4 to 5 days later. For in vivo applications, concentrated virus can be directly injected into the mammalian brain.

**[0093]** For whole-cell and cell-attached recording in cultured hippocampal neurons or acute brain slices, three intracellular solutions containing 4 mM chloride were prepared (135 mM K-Gluconate, 10 mM HEPES, 4 mM KCl, 4 mM MgATP, 0.3 mM Na<sub>3</sub>GTP, titrated to pH 7.2), 10 mM chloride (129 mM K-Gluconate, 10 mM HEPES, 10 mM KCl, 4 mM MgATP, 0.3 mM Na<sub>3</sub>GTP, titrated to pH 7.2), or 25 mM chloride (114 mM K-Gluconate, 10 mM HEPES, 25 mM KCl, 4 mM MgATP, 0.3 mM Na<sub>3</sub>GTP, titrated to pH 7.2).

**[0094]** For cultured hippocampal neurons, Tyrode's solution was employed as the extracellular solution (125 mM

NaCl, 2 mM KCl, 3 mM CaCl<sub>2</sub>, 1 mM MgCl<sub>2</sub>, 30 mM glucose, and 25 mM HEPE, titrated to pH 7.3).

**[0095]** For preparation of acute brain slices, mice were sacrificed 2 weeks after viral injection. 250  $\mu$ m acute brain slices were prepared in ice-cold cutting solution (64 mM NaCl, 25 mM NaHCO<sub>3</sub>, 10 mM glucose, 120 mM sucrose, 2.5 mM KCl, 1.25 mM NaH<sub>2</sub>PO<sub>4</sub>, 0.5 mM CaCl<sub>2</sub>, 7 mM MgCl<sub>2</sub>, and equilibrated with 95% O<sub>2</sub>/5% CO<sub>2</sub>) using a vibratome (VT1000S, Leica). Slices were incubated in oxygenated ACSF (124 mM NaCl, 3 mM KCl, 26 mM NaHCO<sub>3</sub>, 1.25 mM NaH<sub>2</sub>PO<sub>4</sub>, 2.4 mM CaCl<sub>2</sub>, 1.3 mM MgCl<sub>2</sub>, 10 mM glucose, and equilibrated with 95%+O<sub>2</sub>/5% CO<sub>2</sub>) at 32° C. for 30 min to recover.

**[0096]** For calcium imaging, lentiviruses were injected into the cortex of C57BL/6 mice at postnatal day 4 or 5 and acute brain slices were prepared 7 to 8 days later for adult mice.

**[0097]** Transgenic *C. elegans* Lines and Transgenes were experimentally developed using the following procedures. The NpHR gene was placed under the muscle-specific myo-3 promoter (untagged NpHR in transgene zxEx29[pmyo-3::NpHR; lin-15+] and NpHR-ECFP in transgene zxEx30[pmyo-3::NpHR-ECFP; rol-6d]) or under the cholinergic motoneuron specific unc-17 promoter (NpHRECFP in transgene zxEx33[punc-17::NpHR-ECFP; lin-15+]). The NpHR-ECFP fusion (zxEx30 and zxEx34, see below) was employed to assess expression pattern. NpHR-ECFP (zxEx30) animals showed light induced effects that were comparable to the untagged version (zxEx29).

**[0098]** For co-activation of Chr2/NpHR in muscles or cholinergic motoneurons, transgenes zxEx32[pmyo-3::NpHR; pmyo-3::Chr2(H134R)-EYFP; lin-15+] and zxEx34[punc-17::NpHRECFP; punc-17::Chr2(gf)-YFP; rol-6d] were used. Table 1 lists examples of transgenes and worm lines used in various experimental tests.

TABLE 1

Transgene	Genotype	Strain
zxEx29 [p myo-3::NpHR; lin-15 <sup>+</sup> ]	lin-15 (n765ts <sup>-</sup> )	ZX396
zxEx30 [p myo-3::NpHR-ECFP; rol-6d]	N2	ZX397
zxEx32 [p myo-3::NpHR; p myo-3::Chr2(H134R)-EYFP; lin-15 <sup>+</sup> ]	lin-15 (n765ts <sup>-</sup> )	ZX399
zxEx33 [p unc-17::NpHR-ECFP; lin-15 <sup>+</sup> ]	lin-15 (n765ts <sup>-</sup> )	ZX416
zxEx34 [p unc-17::NpHR-ECFP; p unc-17::Chr2(H134R)-EYFP; rol-6d]	N2	ZX417

**[0099]** Experimental tests for bidirectional optical neural control and in vivo implementation were implemented. NpHR in muscle were grown in medium containing ATR. Whole-cell voltage-clamp recordings from dissected muscles indeed demonstrated light-evoked outward currents (265 $\pm$ 82 pA, n=9). To test effects on muscle activity, swimming behavior in liquid medium was analyzed. Consistent with the photocurrents observed, photoactivation of NpHR immediately (within ~150 ms) and essentially completely arrested swimming behavior. As controls, transgenic animals that were raised in the absence of ATR, and wild type animals that were raised with and without ATR were used. Robust paralyzing effects of light were observed, but consistently only in transgenic animals raised in the presence of ATR. When muscle-expressing animals were illuminated for 1 s, they quickly returned to their natural swimming rate after light stimulus termination. When NpHR was activated in muscle for 10 s,

animals remained uncoordinated for prolonged periods (up to 40 seconds), before a full recovery became apparent and normal swimming commenced.

**[0100]** Next, NpHR was targeted to a specific class of genetically defined neurons in vivo. NpHR-ECFP was expressed in cholinergic motoneurons using the vesicular acetylcholine transporter promoter (Punc-17). When illuminated for 1 or 10 s, respectively, these animals also strongly reduced or essentially stopped swimming behavior. These animals, in contrast to the muscle-targeted individuals, recovered to normal swimming behavior immediately, perhaps indicating more powerful  $Cl^-$  homeostasis in neurons than in muscles, although in all cases full recovery was observed consistent with the lack of toxicity observed in mammalian neurons.

**[0101]** When illuminated on solid agar substrate, transgenic animals expressing NpHR either in muscle, or in cholinergic motoneurons, exhibited rapid inhibition of movement and relaxed their bodies, resulting in overall elongation by up to 9% within ~600 ms of illumination. It was found that ChR2 and NpHR could be driven simultaneously in *C. elegans* as well. With either muscle or targeted cholinergic neuron expression (using the Pmyo-3 or Punc-17 promoters, respectively), NpHR rapidly and reversibly counteracted the shortening behavior observed with ChR2 alone. These experiments demonstrate that acetylcholine release can be efficiently triggered from *C. elegans* motoneurons using ChR2, and that ChR2 and NpHR work well together in nematodes as well as mammals.

**[0102]** Slides were developed showing cell-attached (FIG. 4A left) and whole-cell (FIG. 4A right) recording of cultured hippocampal neurons co-expressing ChR2-mCherry and NpHR-EYFP. Action potentials were evoked via trains of blue light pulses (5 Hz trains, 15 ms pulse width, lowest set of bars). NpHR-mediated inhibition was co-administered by brief yellow light pulses (50 ms pulse width, upper sets of bars).

**[0103]** A confocal image was taken from acute mouse brain slice showing membrane-localized NpHR-EYFP expression in the hippocampal CA3 subfield (FIG. 4B left). Current clamp recording showed NpHR-mediated inhibition of specific spikes during a train of action potentials evoked by pulsed current injection (300 pA, 20 Hz, FIG. 4B right).

**[0104]** Epifluorescence images of cortical neurons triple-labeled with NpHR-EYFP, ChR2-mCherry, and Fura-2 showed expression in the neurons. (FIG. 4C)

**[0105]** Simultaneous illumination of cells co-expressing NpHR-EYFP and ChR2-mCherry with steady yellow (continuous illumination, 6 s) and pulsed blue light (50 pulses at 15 ms per flash, 10 Hz) prevented  $[Ca^{2+}]$  transients (FIG. 4D). Subsequent photostimulation of the same cells with blue light pulses (50 pulses at 15 ms per flash, 10 Hz) evoked reliable  $[Ca^{2+}]$  transients. A bar graph was generated that shows the photostimulation-induced fluorescence changes (FIG. 4D, n=6 ChR2-activated triple-labeled cells).

**[0106]** Epifluorescence images showed Pmyo-3-mediated (transgene zxEx30) NpHR-ECFP expression in the body wall muscles of *C. elegans* (FIG. 4E). A muscle voltage clamp trace showed photocurrent in transgenic *C. elegans* expressing NpHR-ECFP (transgene zxEx30) and raised in the presence of ATR. A lack of response in transgenic animal raised in the absence of ATR was noted. Animal postures from three consecutive movie frames (frame rate 12.5 Hz), either with or

without NpHR photoactivation, were superimposed to show lack of movement in NpHR photoactivated animals.

**[0107]** The effect of 10 s illumination on swimming rate (n=10 for each set) in wild type controls, animals expressing NpHR in muscles (transgene zxEx29, FIG. 4F blue), or cholinergic motoneurons (transgene zxEx33, FIG. 4F red) was monitored. The number of swimming cycles per second was counted in bins of 5 s intervals. A briefer 1 s illumination protocol was also used, revealing rapid inhibition during illumination and faster recovery by comparison with the 10 s illumination.

**[0108]** The effect of 1 s illumination on body length (n=5-6 for each set) was monitored (FIG. 4G). Movies were taken from transgenic worms expressing NpHR in muscles (transgene zxEx29) or cholinergic motoneurons (transgene zxEx33). Combined ChR2/NpHR expression in muscle cells (transgene zxEx32) or cholinergic motoneurons (transgene zxEx34) of behaving worms. A plot was generated that shows the body length during the first frame before illumination, the 13 frames during the illumination and the next 11 frames after illumination ended (FIGS. 4F, 4G and 4H) including controls and combined ChR2/NpHR expression in muscle cells (transgene zxEx32) or cholinergic motoneurons (transgene zxEx34) of behaving worms.

**[0109]** NpHR activation significantly reversed the muscle contraction caused by ChR2 activation (n=6 per condition; \*, p<0.05; \*\*, p<0.01; \*\*\*, p<0.001; between consecutive time points; t-test), but not in animals raised in the absence of ATR.

**[0110]** According to a first experimental method, swimming of a transgenic *C. elegans* expressing NpHR (transgene zxEx29) in muscles is instantaneously, and repeatedly, inhibited by photoactivation of HR.

**[0111]** According to a second experimental method, swimming of a transgenic *C. elegans* expressing NpHR in cholinergic motoneurons (transgene zxEx33) is instantaneously inhibited by photoactivation of NpHR.

**[0112]** According to a third experimental method, transgenic *C. elegans* expressing NpHR-ECFP in muscles (transgene zxEx30). Movement is rapidly inhibited (3x) by photoactivation of HR, and the body relaxes and dilates.

**[0113]** According to a fourth experimental method, one transgenic *C. elegans* expressing NpHR in muscles (transgene zxEx29), and one non-transgenic control animal. Movement of the transgenic animal is rapidly inhibited by photoactivation of HR.

**[0114]** According to a fifth experimental method, transgenic *C. elegans* expressing NpHR in cholinergic motoneurons (transgene zxEx33). Movement is rapidly inhibited by photoactivation of HR, and the body relaxes and dilates.

**[0115]** According to a sixth experimental method, co-expression and -activation of ChR2(H134R)-EYFP and NpHR in cholinergic motoneurons of transgenic *C. elegans* (transgene zxEx34). The animal is illuminated with blue light (for ChR2 activation, causing contractions, then, while ChR2 is still photoactivated, NpHR is photoactivated by yellow light, causing significant body relaxation. When NpHR activation ends, the animal contracts again (ChR2 still activated), and finally, when ChR2 activation ends, the animal relaxes to the initial body length.

**[0116]** According to a seventh experimental method, co-expression and rapidly alternating activation of ChR2 (H134R)EYFP and NpHR in muscles of transgenic *C. elegans* (transgene zxEx32). The animal is illuminated with

alternating blue light (for ChR2 activation), causing contractions, and yellow light causing significant body relaxation.

[0117] FIG. 5 depicts an arrangement with multiple light sources, according to an example embodiment of the present invention. FIG. 5 shows light sources 502 and 504 that illuminate proteins 510 and 514. The proteins 510 and 514 are engineered within cell 512 to control current across the cell membrane in response to light from light sources 502 and 504, respectively. In one instance, the first protein 510 functions to dissuade action potential firing, while the second protein 514 functions to encourage action potential firing. Each of proteins 510 and 514 are responsive to light. In a particular instance, the first protein is responsive to light from light source 502 having a wavelength A and the second protein is responsive to light from light source 504 having a wavelength B. Thus, the light sources can be used to control each protein independently. This can be useful for both encouraging and dissuading action potentials in the cell. In another instance, having both types of proteins allows for both positive and negative control of the cell membrane voltage. Thus, the different light sources and proteins could be used to control the voltage or current level (e.g., clamping) of the cell membrane.

[0118] One method of determining responsiveness involves quantifying the responsiveness in terms of the intensity of light required to produce a given response. In some instances, the first or second protein can still be responsive to the alternate wavelength of light although the responsiveness of the protein may be less than that of the primary wavelength. Accordingly, a protein of a first type may have some responsiveness to the wavelength corresponding to the other type of protein while still maintaining sufficient independence of operation. In one such instance, control of the cell can be implemented by shifting either the wavelength of light or the intensity of the light. For instance, the wavelength can be shifted between A and B to induce a corresponding increase or decrease the membrane voltage potential.

[0119] Embodiments of the invention can be implemented with just the protein based ion pump(s). In a specific example, pump 510 is designed to operate using an endogenous cofactor, such as ATR, which can be found in people and many animals. This is particularly useful for minimizing intrusiveness of in vivo applications because it can reduce the need for foreign substances (e.g., cofactors). In a particular instance, pump is a halorhodopsin that acts as an anion pump (e.g., Cl<sup>-</sup>) that is activated in response to light from light source 502 within milliseconds. Such a fast response allows for the system to control (dissuade) individual action potentials in the cell.

[0120] According to one embodiment of the present invention, pump 514 can optionally be implemented for purposes other than dissuading action potential firing, such as controlling the voltage level of cell 508. More specifically, a sensor can be used provide feedback to the light source 502. For instance, this feedback could be a measurement of the voltage or current across the cell membrane. Thus, the light source could be configured to maintain a constant current or voltage (e.g., clamp) across the cell. Moreover, the amount of responsiveness can be controlled by modifying one or more of the intensity and wavelength of the light.

[0121] FIG. 6 shows a system for controlling electrical properties of one or more cells in vivo, according to an example embodiment of the present invention. Control/Interface unit 602 enables/disables light source 604 to illuminate

target cells 608. A delivery mechanism, such as fiber optic cable 606, routes or otherwise directs the light to target cells 608. Fiber optic cable 606 may include a bundle of optical cables, each capable of carrying and directing light independently. Thus, fiber optic cable 606 can be configured to deliver light having one or more wavelengths to multiple locations. Sensor 610 can be implemented, e.g., as an optical device such as an optical scope or as a voltmeter, to provide feedback to control unit 642. In a particular instance, the feedback includes optical imaging of the target cells or of other related cells. In another instance, the feedback could monitor the voltage response of the target cells, including the amount of action potential firing.

[0122] FIG. 7 shows a system for controlling electrical properties of one or more cells in vivo, according to an example embodiment of the present invention. Control/Interface unit 702 enables/disables implantable light source 704, which in turn illuminates target cells 706. Light source 704 is shown with two light source, inhibitory current light source 708 and excitation current light source 710. Light source 708 produces light at a wavelength and intensity that an inhibitory protein is responsive to, while light source 710 produces light at a wavelength and intensity that an excitation protein is responsive to. One skilled in the art would recognize that various configurations of light source 710 are possible, including a single inhibitory light source or an array of light sources having one or more wavelengths. Control/Interface unit 702 communicates with light source 704 through any suitable communication mechanisms, such as wired communications or wireless communications using radio-frequency signals, magnetic signals and the like. As discussed above in connection with FIG. 6, sensor 712 can optionally be implemented for providing feedback to control unit 702.

[0123] Another important aspect of the present invention concerns applications and uses which benefit by reducing toxicity of cells. In certain applications and uses, cells modified to include ion pump molecules can become intolerably toxic. Toxicity can become increasingly problematic as the expression level increases in a cell or the network, for example, when expecting consistent results under repeated tests using the same cell or neural network. A number of embodiments discussed above specifically mention the mammalianized NpHR sequence (GenBank Accession No. EF474018). In connection with the present invention, it has been discovered that this mammalianized NpHR coding sequence has a toxicity that is nearly 100%. It has been discovered that for high expression levels the mammalianized NpHR sequence manifests toxicity at 87% which is considered near enough complete toxicity to be considered as a baseline toxicity reference level which can be substantially reduced using different (NpHR-based but having a different NpHR-based sequence) molecules. Accordingly, various aspects of the present invention are implemented with significantly reduced toxicity.

[0124] The toxicity levels were obtained by a stringent process of identifying any cell abnormality, such as blebs on the cell membrane. For the purposes of this disclosure and the data presented herein, a cell with even single abnormality is considered toxic as are any dead cells. A "toxicity level," as used in this disclosure, means the percentage of cells that are considered toxic.

[0125] As discussed herein, the expression levels are obtained by increasing the original expression levels discussed above (i.e., about 2×10<sup>7</sup> infectious units (ifu) per

milliliter) to one of high expression of at least  $3 \times 10^7$  ifu per milliliter; very high expression of at least  $4 \times 10^7$  ifu per milliliter; ultra high expression of at least  $5 \times 10^7$  ifu per milliliter; or very ultra high expression of at least  $1 \times 10^8$  ifu per milliliter. In a particular embodiment the expression levels can be characterized in terms of their mean photo current being 44 pA or higher.

**[0126]** Various embodiments of the present invention allow for substantially reduced toxicity levels in high expression level (relative to the mammalianized NpHR sequence).

**[0127]** According to one embodiment, an opsin sequence is implemented that exhibits a toxicity of about 72%. A specific example is SPChR2-NpHR, where a signal peptide (first 15aa) from ChR2 is added to the N-terminus: DYGGALSAVGRELL.

**[0128]** According to one embodiment, an opsin sequence is implemented that exhibits a toxicity of about 69%. A specific example is SPnAChR-L-NpHR, where signal peptide (23aa) from nicotinic acetylcholine receptor is added to the N-terminus: MGLRALMLWLLAAAGLVRESLQG.

**[0129]** According to one embodiment, an opsin sequence is implemented that exhibits a toxicity of about 59%. A specific example is NpHR-VSNL, where the PDZ binding motif VSNL is added to the C-terminus.

**[0130]** According to one embodiment, an NpHR coding sequence is implemented with a toxicity of about half of the base-line toxicity. A specific example is an NpHR-based sequence that uses the codons originally present in *Natronomonas pharaonis*. Another example is an NpHR-based sequence where a signal peptide (18aa) from nicotinic acetylcholine receptor is added to the N-terminus: MRGT-PLLLVVSFLSLLQD.

**[0131]** According to another embodiment, an NpHR coding sequence is implemented with a toxicity of between about 34% and 40%. A specific example is an NpHR-based sequence that is formed by adding the PDZ binding motif ETQZ to the C-terminus (NpHR-ETQV).

**[0132]** According to another embodiment, an NpHR coding sequence is implemented with a toxicity of between about 20% and 26%. A specific example is an NpHR-based sequence that is formed by adding the PTPP sequence to the C-terminus to promote interaction with actin-binding protein filamin (NpHR-actin).

**[0133]** According to another embodiment, an NpHR coding sequence is implemented with a toxicity of between about 4% and 10%. A specific example is an NpHR-based sequence that is formed by adding the ER export signal to the C-terminus: VLGSL or, more generally, VXXSL (NpHR-ERexport).

**[0134]** According to another embodiment, an NpHR coding sequence is implemented with a peak current of between about 11.1 pA and 50 pA. A specific example is an NpHR-based sequence that uses the codons originally present in *Natronomonas pharaonis*.

**[0135]** According to another embodiment, an NpHR coding sequence is implemented with a peak current of between about 40 pA and 61 pA. A specific example is an NpHR-based sequence where a signal peptide (18aa) from nicotinic acetylcholine receptor is added to the N-terminus: MRGT-PLLLVVSFLSLLQD.

**[0136]** According to another embodiment, an NpHR coding sequence is implemented with a peak current of between about 49 pA and 77 pA. A specific example is an NpHR-based sequence that is formed by adding the PDZ binding motif ETQZ to the C-terminus (NpHR-ETQV).

**[0137]** According to another embodiment, an NpHR coding sequence is implemented with a peak current of between about 11 pA and 70 pA. A specific example is an NpHR-based sequence that is formed by adding the PTPP sequence to the C-terminus to promote interaction with actin-binding protein filamin (NpHR-actin). Another example is an NpHR-based sequence that is formed by adding the ER export signal to the C-terminus: VLGSL or, more generally, VXXSL (NpHR-ERexport).

**[0138]** Experimental data results showing toxicity and peak current for various NpHR sequences are shown in Table 2.

TABLE 2

Construct	Molecular Modification	Toxicity in neurons	Peak photocurrent (mean $\pm$ s.d)
Humanized NpHR	none	87%	48.0 $\pm$ 7.0 pA
Non-Humanized NpHR	use the original codons from bacteria	37%	29.6 $\pm$ 18.5 pA
SP <sub>nAChR-S</sub> NpHR	Added signal peptide (18aa) from nicotinic acetylcholine receptor to the N-terminus: MRGTPLLLVVSFLSLLQD	37%	51.5 $\pm$ 9.2 pA
NpHR-ETQV	Added the PDZ binding motif ETQV to the C-terminus	34%	63.7 $\pm$ 12.7 pA
NpHR-actin	Added the PTPP sequence to the C-terminus to promote interaction with actin-binding protein filamin	23%	39.8 $\pm$ 20.2 pA
NpHR-ERexport	Added the ER export signal to the C-terminus: VLGSL (more general VXXSL)	7%	40.3 $\pm$ 28.5 pA

**[0139]** Toxicity was assessed in cultured hippocampal neurons as follows: neurons 4 days in vitro were infected with lentivirus for each of the constructs and allowed to accumulate protein for two weeks before assessing toxicity. Cells that displayed large round intracellular blobs either in the soma or dendrites were counted as toxic cells. The photocurrents for each of the constructs were assessed by electrophysiology as described herein and also similar to that taught by “Multimodal fast optical interrogation of neural circuitry” by Zhang, et al, Nature (Apr. 5, 2007) Vol. 446: 633-639, which is fully incorporated herein by reference. It should be noted that while the neurons were allowed to express protein for at least one week, this time frame was about half of the time allotted in various underlying experimental tests discussed above. Additional expression time would allow for more expression, which in turn would result in increased toxicity and photocurrents. Accordingly, assuming a near-linear increase in toxicity, the embodiments showing around 37% toxicity would reach about 74%.

**[0140]** Various embodiments are directed toward a construct that includes ER export signals, including, but not limited to: VXXSL; FXYENE (see “A sequence motif responsible for ER export and surface expression of Kir2.0 inward rectifier K(+) channels” Stockklausner et al., FEBS Lett.; 493 (2-3):129-133 March, 2001; and “Role of ER Export Signals in Controlling Surface Potassium Channel Numbers” Ma et al., Science Vol. 291. no. 5502:316-319, 2001); C-terminal valine residue (see “A Specific Endoplasmic Reticulum Export Signal Drives Transport of Stem Cell Factor (Kit1) to the Cell Surface” Paulhe et al., J. Biol. Chem., Vol. 279, Issue 53, 55545-55555, Dec. 31, 2004); VMI (see



“Signal-dependent export of GABA transporter 1 from the ER-Golgi intermediate compartment is specified by a C-terminal motif” Farhan et al., *J. Cell Sci.* 121:753-761, Feb. 19, 2008.) Each of the above-mentioned references is incorporated herein by reference in their entirety.

**[0141]** Various embodiments are directed toward a construct that includes signal peptides for insertion into plasma membrane including, but not limited to, signal peptides from other opsins or from other transmembrane proteins such as the nicotinic acetylcholine receptor (Isenberg et al., 1989, *J. Neurochemistry*).

**[0142]** For additional information regarding implementation of a signal peptide (first 15aa) from ChR2 added to the N-terminus reference can be made to “Millisecond-timescale, genetically-targeted optical control of neural activity” Boyden, et al., *Nature Neuroscience* 8(9):1263-1268 (2005), which is fully incorporated herein by reference.

**[0143]** For additional information regarding implementation of a signal peptide (23aa) from nicotinic acetylcholine receptor added to the N-terminus reference can be made to Bocquet et al., “A prokaryotic proton-gated ion channel from the nicotinic acetylcholine receptor family” *Nature* 445:116-119, January, 2007.

**[0144]** Various embodiments are directed toward a construct that includes PDZ binding motifs including, but not limited to, X(S/T)XV (e.g., ETQV) or X(S/T)XL (e.g., VSNL).

**[0145]** For additional information regarding implementation of NpHR-VSNL, where the PDZ binding motif VSNL is added to the C-terminus, reference can be made to “Interactions with PDZ proteins are required for L-type calcium channels to activate cAMP response element-binding protein-dependent gene expression” Weick et al., *J. Neurosci.* 23:3446-3456, 2003, which is fully incorporated herein by reference.

**[0146]** For additional information regarding implementation of NpHR-ETQV-based sequences, reference can be made to “Targeting and Readout Strategies for Fast Optical Neural Control In Vitro and In Vivo” Gradinaru, et al., *The Journal of Neuroscience* 27(52):14231-14238, Dec. 26, 2007, which is fully incorporated herein by reference.

**[0147]** For additional information regarding implementation of original codon-based sequences, reference can be made to “Light Driven Proton Pump or Chloride Pump by Halorhodopsin” Bamberg, et al., *Proc. Natl. Acad. Sci. USA* Vol. 90: 639-643, January 1993 *Biophysics*, which is fully incorporated herein by reference.

**[0148]** For additional information regarding implementation of SP<sub>nAChR-S</sub>-pHR-based sequences, reference can be made to “Rapid Communication Cloning of a Putative Neuronal Nicotinic Acetylcholine Receptor Subunit” Isenberg, et al., *J. Neurochem.* 52(3):988-991, 1989, which is fully incorporated herein by reference.

**[0149]** For additional information regarding implementation of NpHR-actin-based sequences, reference can be made to “Localization and Enhanced Current Density of the Kv4.2 Potassium Channel by Interaction with the Actin-binding Protein Filamin” Petrecca, et al., *The Journal of Neuroscience* 20(23):8763-8744, December, 2000, which is fully incorporated herein by reference.

**[0150]** For additional information regarding implementation of ERexport-based sequences, reference can be made to “Surface Expression of Kv1 Voltage-Gated K<sup>+</sup> Channels is

Governed by a C-terminal Motif” Levitan, et al., *TCM* 10(7): 317-320, 2000, which is fully incorporated herein by reference.

**[0151]** The various sequences need not be implemented in isolation. To the contrary, embodiments of the present invention involve various combinations of the above sequences with one another on the same gene. For example, the desired expression levels, peak currents and toxicity levels are tailored through a combination of two or more different sequences within the target cellular structure(s). Specific embodiments involve the selection and use of specific sequences that bind to different portions of the gene (e.g., the C-terminus and the N-terminus). Such selections results in characteristics (e.g., toxicity, current levels and expression levels) not present in embodiments that use only a single sequence. Thus, various embodiments are directed toward combinations of two or more of the above listed modifications. For example, a hybrid construct of SP<sub>nAChR-S</sub>-NpHR-ERexport. Another example involves that addition of ChR2 to the cell.

**[0152]** Thus, various embodiments can be implemented in which two or more constructs are used to express an NpHR-based protein in the cell. Each construct is capable of independently expressing the protein. In one instance, the constructs can be implemented in the same sequence. In another instance, the constructs can be sequentially delivered using two or more different sequences.

**[0153]** Additional constructs can be implemented by co-expressing helper proteins, such as chaperones, that could be useful in aiding NpHR folding and trafficking.

**[0154]** A few example sequence listings are provided in the Appendix, which forms part of this specification. It should be noted that all the sequences contain the EYFP fluorescent protein for visualization purposes. Embodiments of the present invention can be implemented without this EYFP fluorescent protein. For example, each of the sequences can be implemented either on the NpHR alone (with no fluorescent protein) or on the NpHR-X fluorescent protein complex.

**[0155]** Many human applications of the present invention require governmental approval prior to their use. For instance, human use of gene therapy may require such approval. However, similar gene therapies in neurons (nonproliferative cells that are non-susceptible to neoplasms) are proceeding rapidly, with active, FDA-approved clinical trials already underway involving viral gene delivery to human brains. This is likely to facilitate the use of various embodiments of the present invention for a large variety of applications. The following is a non-exhaustive list of a few examples of such applications and embodiments.

**[0156]** Addiction is associated with a variety of brain functions, including reward and expectation. Additionally, the driving cause of addiction may vary between individuals. According to one embodiment, addiction, for example nicotine addiction, may be treated with optogenetic stabilization of small areas on the insula. Optionally, functional brain imaging—for example cued-state PET or fMRI—may be used to locate a hypermetabolic focus in order to determine a precise target spot for the intervention on the insula surface.

**[0157]** Optogenetic excitation of the nucleus accumbens and septum may provide reward and pleasure to a patient without need for resorting to use of substances, and hence may hold a key to addiction treatment. Conversely, optogenetic stabilization of the nucleus accumbens and septum may be used to decrease drug craving in the context of addiction.

In an alternative embodiment, optogenetic stabilization of hypermetabolic activity observed at the genus of the anterior cingulate (BA32) can be used to decrease drug craving. Optogenetic stabilization of cells within the arcuate nucleus of the medial hypothalamus which contain peptide products of pro-opiomelanocortin (POMC) and cocaine-and-amphetamine-regulating transcript (CART) can also be used to decrease drug addiction behavior. For further information in this regard, reference may be made to: Naqvi N H, Rudrauf D, Damasio H, Bechara A. "Damage to the insula disrupts addiction to cigarette smoking." *Science*. 2007 Jan. 26; 315(5811): 531-534, which is fully incorporated herein by reference.

**[0158]** Optogenetic stimulation of neuroendocrine neurons of the hypothalamic periventricular nucleus that secrete somatostatin can be used to inhibit secretion of growth hormone from the anterior pituitary, for example in acromegaly. Optogenetic stabilization of neuroendocrine neurons that secrete somatostatin or growth hormone can be used to increase growth and physical development. Among the changes that accompany "normal" aging, is a sharp decline in serum growth hormone levels after the 4<sup>th</sup> and 5<sup>th</sup> decades. Consequently, physical deterioration associated with aging may be lessened through optogenetic stabilization of the periventricular nucleus.

**[0159]** Optogenetic stabilization of the ventromedial nucleus of the hypothalamus, particularly the pro-opiomelanocortin (POMC) and cocaine-and-amphetamine-regulating transcript (CART) of the arcuate nucleus, can be used to increase appetite, and thereby treat anorexia nervosa. Alternatively, optogenetic stimulation of the lateral nuclei of the hypothalamus can be used to increase appetite and eating behaviors.

**[0160]** Optogenetic excitation in the cholinergic cells of affected areas including the temporal lobe, the NBM (Nucleus basalis of Meynert) and the posterior cingulate gyrus (BA 31) provides stimulation, and hence neurotrophic drive to deteriorating areas. Because the affected areas are widespread within the brain, an analogous treatment with implanted electrodes may be less feasible than an optogenetic approach.

**[0161]** Anxiety disorders are typically associated with increased activity in the left temporal and frontal cortex and amygdala, which trends toward normal as anxiety resolves. Accordingly, the affected left temporal and frontal regions and amygdala may be treated with optogenetic stabilization, so as to dampen activity in these regions.

**[0162]** In normal physiology, photosensitive neural cells of the retina, which depolarize in response to the light that they receive, create a visual map of the received light pattern. Optogenetic ion channels can be used to mimic this process in many parts of the body, and the eyes are no exception. In the case of visual impairment or blindness due to damaged retina, a functionally new retina can be grown, which uses natural ambient light rather than flashing light patterns from an implanted device. The artificial retina grown may be placed in the location of the original retina (where it can take advantage of the optic nerve serving as a conduit back to the visual cortex). Alternatively, the artificial retina may be placed in another location, such as the forehead, provided that a conduit for the depolarization signals are transmitted to cortical tissue capable of deciphering the encoded information from the optogenetic sensor matrix. Cortical blindness could also be treated by simulating visual pathways downstream of the

visual cortex. The stimulation would be based on visual data produced up stream of the visual cortex or by an artificial light sensor.

**[0163]** Treatment of tachycardia may be accomplished with optogenetic stimulation to parasympathetic nervous system fibers including CN X or Vagus Nerve. This causes a decrease in the SA node rate, thereby decreasing the heart rate and force of contraction. Similarly, optogenetic stabilization of sympathetic nervous system fibers within spinal nerves T1 through T4, serves to slow the heart. For the treatment of pathological bradycardia, optogenetic stabilization of the Vagus nerve, or optogenetic stimulation of sympathetic fibers in T1 through T4 will serve to increase heart rate. Cardiac dysrhythmias resulting from aberrant electrical foci that outpace the sinoatrial node may be suppressed by treating the aberrant electrical focus with moderate optogenetic stabilization. This decreases the intrinsic rate of firing within the treated tissue, and permits the sinoatrial node to regain its role in pacing the heart's electrical system. In a similar way, any type of cardiac arrhythmia could be treated. Degeneration of cardiac tissue that occurs in cardiomyopathy or congestive heart failure could also be treated using this invention; the remaining tissue could be excited using various embodiments of the invention.

**[0164]** Optogenetic excitation stimulation of brain regions including the frontal lobe, parietal lobes and hippocampi, may increase processing speed, improve memory, and stimulate growth and interconnection of neurons, including spurring development of neural progenitor cells. As an example, one such application of the present invention is directed to optogenetic excitation stimulation of targeted neurons in the thalamus for the purpose of bringing a patient out of a near-vegetative (barely-conscious) state. Growth of light-gated ion channels or pumps in the membrane of targeted thalamus neurons is effected. These modified neurons are then stimulated, e.g., via optics which may also gain access by the same passageway, by directing a flash of light thereupon so as to modulate the function of the targeted neurons and/or surrounding cells. For further information regarding appropriate modulation techniques (via electrode-based treatment) or further information regarding the associated brain regions for such patients, reference may be made to: Schiff N D, Giacino J T, Kalmar K, Victor J D, Baker K, Gerber M, Fritz B, Eisenberg B, O'Connor J O, Kobylarz E J, Farris S, Machado A, McCagg C, Plum F, Fins J J, Rezai A R. Behavioral improvements with thalamic stimulation after severe traumatic brain injury. *Nature*. Vol 448. Aug. 2, 2007 pp 600-604.

**[0165]** In an alternative embodiment, optogenetic excitation may be used to treat weakened cardiac muscle in conditions such as congestive heart failure. Electrical assistance to failing heart muscle of CHF is generally not practical, due to the thin-stretched, fragile state of the cardiac wall, and the difficulty in providing an evenly distributed electrical coupling between an electrodes and muscle. For this reason, preferred methods to date for increasing cardiac contractility have involved either pharmacological methods such as Beta agonists, and mechanical approaches such as ventricular assist devices. In this embodiment of the present invention, optogenetic excitation is delivered to weakened heart muscle via light emitting elements on the inner surface of a jacket surround the heart or otherwise against the affected heart wall. Light may be diffused by means well known in the art, to smoothly cover large areas of muscle, prompting contraction with each light pulse.

**[0166]** Optogenetic stabilization in the subgenual portion of the cingulate gyrus (Cg25), yellow light may be applied with an implanted device. The goal would be to treat depression by suppressing target activity in manner analogous to what is taught by Mayberg H S et al., Deep Brain Stimulation for Treatment-Resistant Depression. *Neuron*, Vol. 45, 651-660, Mar. 3, 2005, 651-660, which is fully incorporated herein by reference. In an alternative embodiment, an optogenetic excitation stimulation method is to increase activity in that region in a manner analogous to what is taught by Schlaepfer et al., Deep Brain stimulation to Reward Circuitry Alleviates Anhedonia in Refractory Major Depression, *Neuropsychopharmacology* 2007 1-10, which is fully incorporated herein by reference. In yet another embodiment the left dorsolateral prefrontal cortex (LDLPFC) is targeted with an optogenetic excitation stimulation method. Pacing the LDLPFC at 5-20 Hz serves to increase the basal metabolic level of this structure which, via connecting circuitry, serves to decrease activity in Cg 25, improving depression in the process. Suppression of the right dorsolateral prefrontal cortex (RDLDPFC) is also an effective depression treatment strategy. This may be accomplished by optogenetic stabilization on the RDLDPFC, or suppression may also be accomplished by using optogenetic excitation stimulation, and pulsing at a slow rate—1 Hz or less, improving depression in the process. Vagus nerve stimulation (VNS) may be improved using an optogenetic approach. Use of optogenetic excitation may be used in order to stimulate only the vagus afferents to the brain, such as the nodose ganglion and the jugular ganglion. Efferents from the brain would not receive stimulation by this approach, thus eliminating some of the side-effects of VNS including discomfort in the throat, a cough, difficulty swallowing and a hoarse voice. In an alternative embodiment, the hippocampus may be optogenetically excited, leading to increased dendritic and axonal sprouting, and overall growth of the hippocampus. Other brain regions implicated in depression that could be treated using this invention include the amygdala, accumbens, orbitofrontal and orbitomedial cortex, hippocampus, olfactory cortex, and dopaminergic, serotonergic, and noradrenergic projections. Optogenetic approaches could be used to control spread of activity through structures like the hippocampus to control depressive symptoms.

**[0167]** So long as there are viable alpha and beta cell populations in the pancreatic islets of Langerhans, the islets can be targeted for the treatment of diabetes. For example, when serum glucose is high (as determined manually or by closed loop glucose detection system), optogenetic excitation may be used to cause insulin release from the beta cells of the islets of Langerhans in the pancreas, while optogenetic stabilization is used to prevent glucagon release from the alpha cells of the islets of Langerhans in the pancreas. Conversely, when blood sugars are too low (as determined manually or by closed loop glucose detection system), optogenetic stabilization may be used to stop beta cell secretion of insulin, and optogenetic excitation may be used to increase alpha-cell secretion of glucagon.

**[0168]** For treatment of epilepsy, quenching or blocking epileptogenic activity is amenable to optogenetic approaches. Most epilepsy patients have a stereotyped pattern of activity spread resulting from an epileptogenic focus. Optogenetic stabilization could be used to suppress the abnormal activity before it spreads or truncated it early in its course. Alternatively, activation of excitatory tissue via optogenetic excita-

tion stimulation could be delivered in a series of deliberately asynchronous patterns to disrupt the emerging seizure activity. Another alternative involves the activation of optogenetic excitation stimulation in GABAergic neurons to provide a similar result. Thalamic relays may be targeted with optogenetic stabilization triggered when an abnormal EEG pattern is detected.

**[0169]** Another embodiment involves the treatment of gastrointestinal disorders. The digestive system has its own, semi-autonomous nervous system containing sensory neurons, motor neurons and interneurons. These neurons control movement of the GI tract, as well as trigger specific cells in the gut to release acid, digestive enzymes, and hormones including gastrin, cholecystokinin and secretin. Syndromes that include inadequate secretion of any of these cellular products may be treated with optogenetic stimulation of the producing cell types, or neurons that prompt their activity. Conversely, optogenetic stabilization may be used to treat syndromes in which excessive endocrine and exocrine products are being created. Disorders of lowered intestinal motility, ranging from constipation (particularly in patients with spinal cord injury) to megacolon may be treated with optogenetic excitation of motor neurons in the intestines. Disorders of intestinal hypermotility, including some forms of irritable bowel syndrome may be treated with optogenetic stabilization of neurons that control motility. Neurogenic gastric outlet obstructions may be treated with optogenetic stabilization of neurons and musculature in the pylorus. An alternative approach to hypomotility syndromes would be to provide optogenetic excitation to stretch-sensitive neurons in the walls of the gut, increasing the signal that the gut is full and in need of emptying.

**[0170]** In this same paradigm, an approach to hypermotility syndromes of the gut would be to provide optogenetic stabilization to stretch receptor neurons in the lower GI, thus providing a “false cue” that the gut was empty, and not in need of emptying. In the case of frank fecal incontinence, gaining improved control of the internal and external sphincters may be preferred to slowing the motility of the entire tract. During periods of time during which a patient needs to hold feces in, optogenetic excitation of the internal anal sphincter will provide for retention. Providing optogenetic stimulation to the external sphincter may be used to provide additional continence. When the patient is required to defecate, the internal anal sphincter, and then external anal sphincter should be relaxed, either by pausing the optogenetic stimulation, or by adding optogenetic stabilization.

**[0171]** Conductive hearing loss may be treated by the use of optical cochlear implants. Once the cochlea has been prepared for optogenetic stimulation, a cochlear implant that flashes light may be used. Sensorineural hearing loss may be treated through optical stimulation of downstream targets in the auditory pathway.

**[0172]** Another embodiment of the present invention is directed toward the treatment of blood pressure disorders, such as hypertension. Baroreceptors and chemoreceptors in regions such as the aorta (aortic bodies and paraaortic bodies) and the carotid arteries (“carotid bodies”) participate the regulation of blood pressure and respiration by sending afferents via the vagus nerve (CN X), and other pathways to the medulla and pons, particularly the solitary tract and nucleus. Optogenetic excitation of the carotid bodies, aortic bodies, paraaortic bodies, may be used to send a false message of “hypertension” to the solitary nucleus and tract, causing it to

report that blood pressure should be decreased. Optogenetic excitation or stabilization directly to appropriate parts of the brainstem may also be used to lower blood pressure. The opposite modality causes the optogenetic approach to serve as a pressor, raising blood pressure. A similar effect may also be achieved via optogenetic excitation of the Vagus nerve, or by optogenetic stabilization of sympathetic fibers within spinal nerves T1-T4. In an alternative embodiment, hypertension may be treated with optogenetic stabilization of the heart, resulting in decreased cardiac output and lowered blood pressure. According to another embodiment, optogenetic stabilization of aldosterone-producing cells within the adrenal cortex may be used to decrease blood pressure. In yet another alternative embodiment, hypertension may be treated by optogenetic stabilization of vascular smooth muscle. Activating light may be passed transcutaneously to the peripheral vascular bed.

**[0173]** Another example embodiment is directed toward the treatment of hypothalamic-pituitary-adrenal axis disorders. In the treatment of hypothyroidism, optogenetic excitation of parvocellular neuroendocrine neurons in the paraventricular and anterior hypothalamic nuclei can be used to increase secretion of thyrotropin-releasing hormone (TRH). TRH, in turn, stimulates anterior pituitary to secrete TSH. Conversely, hyperthyroidism may be treated with optogenetic stabilization of the parvocellular neuroendocrine neurons. For the treatment of adrenal insufficiency, or of Addison's disease, optogenetic excitation of parvocellular neuroendocrine neurons in the supraoptic nucleus and paraventricular nuclei may be used to increase the secretion of vasopressin, which, with the help of corticotropin-releasing hormone (CRH), stimulate anterior pituitary to secrete ACTH. Cushing syndrome, frequently caused by excessive ACTH secretion, may be treated with optogenetic stabilization of the parvocellular neuroendocrine neurons of supraoptic nucleus via the same physiological chain of effects described above. Neuroendocrine neurons of the arcuate nucleus produce dopamine, which inhibits secretion of prolactin from the anterior pituitary. Hyperprolactinemia can therefore be treated via optogenetic excitation, while hypoprolactinemia can be treated with optogenetic stabilization of the neuroendocrine cells of the arcuate nucleus.

**[0174]** In the treatment of hyperautonomic states, for example anxiety disorders, optogenetic stabilization of the adrenal medulla may be used to reduce norepinephrine output. Similarly, optogenetic stimulation of the adrenal medulla may be used in persons with need for adrenaline surges, for example those with severe asthma, or disorders that manifest as chronic sleepiness.

**[0175]** Optogenetic stimulation of the adrenal cortex will cause release of chemicals including cortisol, testosterone, and aldosterone. Unlike the adrenal medulla, the adrenal cortex receives its instructions from neuroendocrine hormones secreted from the pituitary and hypothalamus, the lungs, and the kidneys. Regardless, the adrenal cortex is amenable to optogenetic stimulation. Optogenetic stimulation of the cortisol-producing cells of the adrenal cortex may be used to treat Addison's disease. Optogenetic stabilization of cortisol-producing cells of the adrenal cortex may be used to treat Cushing's disease. Optogenetic stimulation of testosterone-producing cells may be used to treat disorders of sexual interest in women: Optogenetic stabilization of those same cells may be used to decrease facial hair in women. Optogenetic stabilization of aldosterone-producing cells within the

adrenal cortex may be used to decrease blood pressure. Optogenetic excitation of aldosterone-producing cells within the adrenal cortex may be used to increase blood pressure.

**[0176]** Optogenetic excitation stimulation of specific affected brain regions may be used to increase processing speed, and stimulate growth and interconnection of neurons, including spurring the maturation of neural progenitor cells. Such uses can be particularly useful for treatment of mental retardation.

**[0177]** According to another embodiment of the present invention, various muscle diseases and injuries can be treated. Palsies related to muscle damage, peripheral nerve damage and to dystrophic diseases can be treated with optogenetic excitation to cause contraction, and optogenetic stabilization to cause relaxation. This latter relaxation via optogenetic stabilization approach can also be used to prevent muscle wasting, maintain tone, and permit coordinated movement as opposing muscle groups are contracted. Likewise, frank spasticity can be treated via optogenetic stabilization.

**[0178]** In areas as diverse as peripheral nerve truncation, stroke, traumatic brain injury and spinal cord injury, there is a need to foster the growth of new neurons, and assist with their integration into a functional network with other neurons and with their target tissue. Re-growth of new neuronal tracts may be encouraged via optogenetic excitation, which serves to signal stem cells to sprout axons and dendrites, and to integrate themselves with the network. Use of an optogenetic technique (as opposed to electrodes) prevents receipt of signals by intact tissue, and serves to ensure that new target tissue grows by virtue of a communication set up with the developing neurons, and not with an artificial signal like current emanating from an electrode.

**[0179]** Obesity can be treated with optogenetic excitation to the ventromedial nucleus of the hypothalamus, particularly the pro-opiomelanocortin (POMC) and cocaine-and-amphetamine-regulating transcript (CART) of the arcuate nucleus. In an alternative embodiment, obesity can be treated via optogenetic stabilization of the lateral nuclei of the hypothalamus. In another embodiment, optogenetic stimulation to leptin-producing cells, or to cells with leptin receptors within the hypothalamus may be used to decrease appetite and hence treat obesity.

**[0180]** Destructive lesions to the anterior capsule, and analogous DBS to that region are established means of treating severe, intractable obsessive-compulsive disorder 48 (OCD48). Such approaches may be emulated using optogenetic stabilization to the anterior limb of the internal capsule, or to regions such as BA32 and Cg24 which show metabolic decrease as OCD remits.

**[0181]** Chronic Pain can be treated using another embodiment of the present invention. Electrical stimulation methods include local peripheral nerve stimulation, local cranial nerve stimulation and "subthreshold" motor cortex stimulation. Reasonable optogenetic approaches include optogenetic stabilization at local painful sites. Attention to promoter selection would ensure that other sensory and motor fibers would be unaffected. Selective optogenetic excitation of interneurons at the primary motor cortex also may provide effective pain relief. Also, optogenetic stabilization at the sensory thalamus, (particularly medial thalamic nuclei), periventricular grey matter, and ventral raphe nuclei, may be used to produce pain relief. In an alternative embodiment, optogenetic stabilization of parvalbumin-expressing cells targeting as targeting strategy, may be used to treat pain by decreasing Sub-

stance P production. The release of endogenous opioids may be accomplished by using optogenetic excitation to increase activity in the nucleus accumbens. In an alternative embodiment, when POMC neurons of the arcuate nucleus of the medial hypothalamus are optogenetically excited, beta endorphin are increased, providing viable treatment approaches for depression and for chronic pain.

**[0182]** Parkinson's Disease can be treated by expressing optogenetic stabilization in the glutamatergic neurons in either the subthalamic nucleus (STN) or the globus pallidus interna (GPi) using an excitatory-specific promoter such as CaMKII $\alpha$ , and apply optogenetic stabilization. Unlike electrical modulation in which all cell-types are affected, only glutamatergic STN neurons would be suppressed.

**[0183]** Certain personality disorders, including the borderline and antisocial types, demonstrate focal deficits in brain disorders including "hypofrontality." Direct or indirect optogenetic excitation of these regions is anticipated to produce improvement of symptoms. Abnormal bursts of activity in the amygdala are also known to precipitate sudden, unprompted flights into rage: a symptom of borderline personality disorder, as well as other conditions, which can benefit from optogenetic stabilization of the amygdala. Optogenetic approaches could improve communication and synchronization between different parts of the brain, including amygdala, striatum, and frontal cortex, which could help in reducing impulsiveness and improving insight.

**[0184]** The amygdalocentric model of post-traumatic-stress disorder (PTSD) proposes that it is associated with hyperarousal of the amygdala and insufficient top-down control by the medial prefrontal cortex and the hippocampus. Accordingly, PTSD may be treated with optogenetic stabilization of the amygdala or hippocampus.

**[0185]** Schizophrenia is characterized by abnormalities including auditory hallucinations. These might be treated by suppression of the auditory cortex using optogenetic stabilization. Hypofrontality associated with schizophrenia might be treated with optogenetic excitation in the affected frontal regions. Optogenetic approaches could improve communication and synchronization between different parts of the brain which could help in reducing misattribution of self-generated stimuli as foreign.

**[0186]** Optogenetic stabilization of cells within the arcuate nucleus of the medial hypothalamus, which contain peptide products of pro-opiomelanocortin (POMC) and cocaine-and-amphetamine-regulating transcript (CART) can be used to reduce compulsive sexual behavior. Optogenetic excitation of cells within the arcuate nucleus of the medial hypothalamus which contain peptide products of pro-opiomelanocortin (POMC) and cocaine-and-amphetamine-regulating transcript (CART) may be used to increase sexual interest in the treatment of cases of disorders of sexual desire. In the treatment of disorders of hypoactive sexual desire testosterone production by the testes and the adrenal glands can be increased through optogenetic excitation of the pituitary gland. Optogenetic excitation of the nucleus accumbens can be used for the treatment of anorgasmia.

**[0187]** The suprachiasmatic nucleus secretes melatonin, which serves to regulate sleep/wake cycles. Optogenetic excitation to the suprachiasmatic nucleus can be used to increase melatonin production, inducing sleep, and thereby treating insomnia. Orexin (hypocretin) neurons strongly excite numerous brain nuclei in order to promote wakefulness. Optogenetic excitation of orexin-producing cell populations can be used to treat narcolepsy, and chronic daytime sleepiness.

**[0188]** Optogenetic stimulation of the supraoptic nucleus may be used to induce secretion of oxytocin, can be used to promote parturition during childbirth, and can be used to treat disorders of social attachment.

**[0189]** Like muscular palsies, the motor functions that have been de-afferented by a spinal cord injury may be treated with optogenetic excitation to cause contraction, and optogenetic stabilization to cause relaxation. This latter relaxation via optogenetic stabilization approach may also be used to prevent muscle wasting, maintain tone, and permit coordinated movement as opposing muscle groups are contracted. Likewise, frank spasticity may be treated via optogenetic stabilization. Re-growth of new spinal neuronal tracts may be encouraged via optogenetic excitation, which serves to signal stem cells to sprout axons and dendrites, and to integrate themselves with the network.

**[0190]** Stroke deficits include personality change, motor deficits, sensory deficits, cognitive loss, and emotional instability. One strategy for the treatment of stroke deficits is to provide optogenetic stimulation to brain and body structures that have been deafferented from excitatory connections. Similarly, optogenetic stabilization capabilities can be imparted on brain and body structures that have been deafferented from inhibitory connections.

**[0191]** Research indicates that the underlying pathobiology in Tourette's syndrome is a phasic dysfunction of dopamine transmission in cortical and subcortical regions, the thalamus, basal ganglia and frontal cortex. In order to provide therapy, affected areas are preferably first identified using techniques including functional brain imaging and magnetoencephalography (MEG). Whether specifically identified or not, optogenetic stabilization of candidate tracts may be used to suppress motor tics. Post-implantation empirical testing of device parameters reveals which sites of optogenetic stabilization, and which are unnecessary to continue.

**[0192]** In order to treat disorders of urinary or fecal incontinence optogenetic stabilization can be used to the sphincters, for example via optogenetic stabilization of the bladder detrussor smooth muscle or innervations of that muscle. When micturation is necessary, these optogenetic processes are turned off, or alternatively can be reversed, with optogenetic stabilization to the (external) urinary sphincter, and optogenetic excitation of the bladder detrussor muscle or its innervations. When a bladder has been deafferented, for example, when the sacral dorsal roots are cut or destroyed by diseases of the dorsal roots such as tabes dorsalis in humans, all reflex contractions of the bladder are abolished, and the bladder becomes distended. Optogenetic excitation of the muscle directly can be used to restore tone to the detrussor, prevent kidney damage, and to assist with the micturition process. As the bladder becomes "decentralized" and hypersensitive to movement, and hence prone to incontinence, optogenetic stabilization to the bladder muscle can be used to minimize this reactivity of the organ.

**[0193]** In order to selectively excite/inhibit a given population of neurons, for example those involved in the disease state of an illness, several strategies can be used to target the optogenetic proteins/molecules to specific populations.

**[0194]** For various embodiments of the present invention, genetic targeting may be used to express various optogenetic proteins or molecules. Such targeting involves the targeted expression of the optogenetic proteins/molecules via genetic control elements such as promoters (e.g., Parvalbumin, Somatostatin, Cholecystokinin, GFAP), enhancers/silencers (e.g., Cytomegalovirus Immediate Early Enhancer), and other transcriptional or translational regulatory elements (e.g. Woodchuck Hepatitis Virus Post-transcriptional Regulatory

Element). Permutations of the promoter+enhancer+regulatory element combination can be used to restrict the expression of optogenetic probes to genetically-defined populations.

**[0195]** Various embodiments of the present invention may be implemented using spatial/anatomical targeting. Such targeting takes advantage of the fact that projection patterns of neurons, virus or other reagents carrying genetic information (DNA plasmids, fragments, etc), can be focally delivered to an area where a given population of neurons project to. The genetic material will then be transported back to the bodies of the neurons to mediate expression of the optogenetic probes. Alternatively, if it is desired to label cells in a focal region, viruses or genetic material may be focally delivered to the interested region to mediate localized expression.

**[0196]** Various gene delivery systems are useful in implementing one or more embodiments of the present invention. One such delivery system is Adeno-Associated Virus (AAV). AAV can be used to deliver a promoter+optogenetic probe cassette to a specific region of interest. The choice of promoter will drive expression in a specific population of neurons. For example, using the CaMKIIa promoter will drive excitatory neuron specific expression of optogenetic probes. AAV will mediate long-term expression of the optogenetic probe for at least 1 year or more. To achieve more specificity, AAV may be pseudotyped with specific serotypes 1 to 8, with each having different tropism for different cell types. For instance, serotype 2 and 5 is known to have good neuron-specific tropism.

**[0197]** Another gene deliver mechanism is the use of a retrovirus. HIV or other lentivirus-based retroviral vectors may be used to deliver a promoter+optogenetic probe cassette to a specific region of interest. Retroviruses may also be pseudotyped with the Rabies virus envelope glycoprotein to achieve retrograde transport for labeling cells based on their axonal projection patterns. Retroviruses integrate into the host cell's genome, therefore are capable of mediating permanent expression of the optogenetic probes. Non-lentivirus based retroviral vectors can be used to selectively label dividing cells.

**[0198]** Gutless Adenovirus and Herpes Simplex Virus (HSV) are two DNA based viruses that can be used to deliver promoter+optogenetic probe cassette into specific regions of the brain as well. HSV and Adenovirus have much larger packaging capacities and therefore can accommodate much larger promoter elements and can also be used to deliver multiple optogenetic probes or other therapeutic genes along with optogenetic probes.

**[0199]** Focal Electroporation can also be used to transiently transfect neurons. DNA plasmids or fragments can be focally delivered into a specific region of the brain. By applying mild electrical current, surrounding local cells will receive the DNA material and expression of the optogenetic probes.

**[0200]** In another instance, lipofection can be used by mixing genetic material with lipid reagents and then subsequently injected into the brain to mediate transfect of the local cells.

**[0201]** Various embodiments involve the use of various control elements. In addition to genetic control elements, other control elements (particularly promoters and enhancers whose activities are sensitive to chemical, magnetic stimulation, or infrared radiation) can be used to mediate temporally-controlled expression of the optogenetic probes. For example, a promoter whose transcriptional activity is subject to infrared radiation allows one to use focused radiation to fine tune the expression of optogenetic probes in a focal region at only the desired time.

**[0202]** According to one embodiment of the present invention, the invention may be used in animal models of DBS, for example in Parkinsonian rats, to identify the target cell types responsible for therapeutic effects (an area of intense debate and immense clinical importance). This knowledge alone may lead to the development of improved pharmacological and surgical strategies for treating human disease.

**[0203]** According to another embodiment of the present invention, genetically-defined cell types may be linked with complex systems-level behaviors, and may allow the elucidation of the precise contribution of different cell types in many different brain regions to high-level organismal functioning.

**[0204]** Other aspects and embodiments are directed to systems, methods, kits, compositions of matter and molecules for ion pumps or for controlling inhibitory currents in a cell (e.g., in in vivo and in vitro environments). As described throughout this disclosure, including the claims, such systems, methods, kits, compositions of matter are realized in manners consistent herewith. For example, in one embodiment, the present invention is directed to an assembly or kit of parts, having a product containing an NpHR-based molecular variant and another opsin-based molecule (ChR2-based and or NpHR-based) as a combined preparation for use in the treatment of disease of a neurological or CNS disorder (as a category of disorder types or a specific disorder as exemplified herein), wherein at least the NpHR-based molecular variant is useful for expressing a light-activated NpHR-based molecule that responds to light by producing an inhibitory current to dissuade depolarization of a cell, and wherein a high expression of the molecule manifests a toxicity level that is less than about 75%.

**[0205]** The various embodiments described above are provided by way of illustration only and should not be construed to limit the invention. Based on the above discussion and illustrations, those skilled in the art will readily recognize that various modifications and changes may be made to the present invention without strictly following the exemplary embodiments and applications illustrated and described herein. For instance, such changes may include additional NPHR-based sequences other than those listed in the immediately following Appendix. Such modifications and changes do not depart from the true spirit and scope of the present invention, which is set forth in the following appended claims.

---

SEQUENCE LISTING

<160> NUMBER OF SEQ ID NOS: 10

<210> SEQ ID NO 1

<211> LENGTH: 1599

<212> TYPE: DNA

<213> ORGANISM: Artificial Sequence

<220> FEATURE:

-continued

---

<223> OTHER INFORMATION: humanized codon optimized sequence from  
Natronomonas pharaonis

<400> SEQUENCE: 1

atgacagaga ccctgcctcc cgtgaccgag agtgccgtgg cccttcaagc cgagggtacc 60  
 caaagggagt tgttcgagtt cgtgctgaac gaccctttgc ttgcaagcag tctctatata 120  
 aacatcgcac ttgcaggact gagtatactg ctgttcgttt ttatgaccgg aggactcgat 180  
 gatccacggg caaaacttat tgctgtgtca accatccttg tgectgtcgt cagcattgcc 240  
 tcctacactg gattggcgag cggcctgaca atttccgttc ttgaaatgcc agcggggccat 300  
 tttgcagaag gcagctcagt gatgctggga ggagaagagg tagatggtgt agtcaccatg 360  
 tggggacggg atctcacctg ggcactttcc acgcccataa ttctcctcgc tctgggtctc 420  
 ctggccggaa gcaatgctac aaagctcttc acagctatca ctttcgatata cgctatgtgc 480  
 gtgactggcc ttgccgcggc cctgactacc tcctcccacc tcatgagatg gttctggtac 540  
 gctatcagtt gtgcatgctt tctgggtggc ttgtatatcc tgctggtgga gtgggcacag 600  
 gacgccaaag ccgcggggaa cgctgacatg ttcaataccc tgaagctgtt gacagtagtg 660  
 atgtggctgg ggtatccaat tgtgtgggct cttggagtcg agggatcgc ggtgttgccc 720  
 gttgggggta cgagctgggg atattctttc ctggatatcg tggcaaagta cattttcgca 780  
 ttcttgctcc tgaactatct gacgtcaaac gaatctgtcg tgtccggcag cattttggat 840  
 gttccatctg cttctgggac cccggctgat gatgcggccg ccgtgagcaa gggcgaggag 900  
 ctgttcaccg ggggtggtgc catcctggtc gagctggacg gcgacgtaa cggccacaag 960  
 ttcagcgtgt ccggcgaggg cgagggcgat gccacctacg gcaagctgac cctgaagtcc 1020  
 atctgcacca ccggcaagct gcccgtgccc tggcccaccc tcgtgaccac cttcggctac 1080  
 ggctgcagt gcttcgcccg ctaccccgac cacatgaagc agcacgactt cttcaagtcc 1140  
 gccatgcccg aaggctacgt ccaggagcgc accatcttct tcaaggacga cggcaactac 1200  
 aagaccgcg ccgaggtgaa gttcagggc gacaccctgg tgaaccgcat cgagctgaag 1260  
 ggcatcgact tcaaggagga cggcaacatc ctggggcaca agctggagta caactacaac 1320  
 agccacaacg tctatatcat ggccgacaag cagaagaacg gcatcaaggt gaacttcaag 1380  
 atccgccaca acatcgagga cggcagcgtg cagctcggcg accactacca gcagaacacc 1440  
 cccatcggcg acggccccgt gctgctgccc gacaaccact acctgagcta ccagtccgcc 1500  
 ctgagcaaag accccaacga gaagcgcgat cacatggtcc tgctggagtt cgtgaccgcc 1560  
 gccgggatca ctctcgcat ggacgagctg tacaagtaa 1599

<210> SEQ ID NO 2

<211> LENGTH: 1599

<212> TYPE: DNA

<213> ORGANISM: Artificial Sequence

<220> FEATURE:

<223> OTHER INFORMATION: Original codons from from Natronomonas  
pharaonis with EYEFP

<400> SEQUENCE: 2

atgactgaga cattgccacc ggtaacggaa tcggctgttg cgctacaggc ggaggtgacc 60  
 cagagggagc tgttcgagtt cgttctcaac gacccccctc tcgccagttc gctgtatatt 120  
 aatatcgcac tggcagggct gtcgatactg cttttcgtgt tcatgacgcg cggactcgac 180

-continued

---

```

gaccacggg cgaaactcat cgccgtttcg acgattttgg tgccggtggt ctctatcgcg 240
agctacaccg gccttgcatc ggggctcacc atcagcgtec tcgagatgcc agccggccac 300
ttcgccgagg ggtcctcggg gatgctcggc ggcgaagagg tagacggcgt cgtgacgatg 360
tggggccgct atctgacgtg ggccctttcg acaccgatga tactgctggc gcttgggctg 420
cttgctggct ctaacgccac gaagctcttt accgccatca ccttcgacat cgcgatgtgt 480
gtcaccggcc tcgcagccgc gctgacgacc tcttcgcacc tgatgcggtg gttctggtag 540
gccatcagtt gtgcgtggtt cctcgtcgtc ctctacatcc tgctcgtcga gtgggcacag 600
gacgccaagg ctgccgttac tgcggatatg ttcaatacgc tgaagctgct gaccgttgct 660
atgtggctcg gctaccccat cgtgtgggca ctccggcgtt agggcatcgc cgttcttccg 720
gtcggagtca cgtcgtgggg atacagcttc ctgcacatcg tcgcgaagta catcttcgcg 780
ttcctgctgc tcaactacct cacgtcgaac gagagcgtcg tctccggctc gatactcgac 840
gtgccgtccg cgtcgggac tcccgtgac gacgcggccg ccgtgagcaa gggcgaggag 900
ctgttcaccg ggggtgtgcc catcctggtc gagctggacg gcgacgtaa cggccacaag 960
ttcagcgtgt ccggcgaggg cgagggcgat gccacctacg gcaagctgac cctgaagtcc 1020
atctgcacca ccggcaagct gcccggtgcc tggcccaccc tcgtgaccac cttcggctac 1080
ggcctgcagt gcttcgcccg ctaccccgac cacatgaagc agcacgactt cttcaagtcc 1140
gccatgcccg aaggctacgt ccaggagcgc accatcttct tcaaggacga cggcaactac 1200
aagaccgcg cggaggtgaa gttcaggggc gacaccctgg tgaaccgcat cgagctgaag 1260
ggcatcgact tcaaggagga cggcaacatc ctggggcaca agctggagta caactacaac 1320
agccacaacg tctatatcat ggccgacaag cagaagaacg gcatcaaggt gaacttcaag 1380
atccgccaca acatcgagga cggcagcgtg cagctcggc accactacca gcagaacacc 1440
cccatcggcg acggccccgt gctgctgccc gacaaccact acctgagcta ccagtccgcc 1500
ctgagcaaag accccaacga gaagcgcgat cacatggtcc tgctggagtt cgtgaccgcc 1560
gccgggatca ctctcggcat ggacgagctg tacaagtaa 1599

```

&lt;210&gt; SEQ ID NO 3

&lt;211&gt; LENGTH: 1641

&lt;212&gt; TYPE: DNA

&lt;213&gt; ORGANISM: Artificial Sequence

&lt;220&gt; FEATURE:

```

<223> OTHER INFORMATION: humanized codon optimized sequence from
    Natronomonas pharaonis with signal peptide (23aa) from nicotinic
    acetylcholine receptor added to the N-terminus

```

&lt;400&gt; SEQUENCE: 3

```

atgaggggta cgcccctgct cctcgtcgtc tctctgttct ctctgcttca ggacacagag 60
accctgcctc ccgtgaccga gagtgccgtg gcccttcaag ccgaggttac ccaaggggag 120
ttgttcgagt tcgtgctgaa cgaccctttg cttgcaagca gtctctatat caacatcgca 180
cttgccaggac tgagtatact gctgttcggt tttatgacct gaggactcga tgatccacgg 240
gcaaaaactta ttgctgtgtc aaccatcctt gtgcctgtcg tcagcattgc ctactacact 300
ggattggcga gggcctgac aatttccggt cttgaaatgc cagcgggcca ttttgagaa 360
ggcagctcag tgatgctggg aggagaagag gtagatggtg tagtcacat gtggggacgg 420
tatctcaact gggcactttc cagcccatg attctcctcg ctctgggtct cctggccgga 480

```



-continued

---

```

agcaatgcta caaagctctt cacagctatc actttcgata tcgctatgtg cgtgactggc 540
cttgccgagg cctgactac ctectccac ctcatgagat ggttctggta cgctatcagt 600
tgtgcatgct ttctgggtgt cttgtatata ctgctgggtg agtgggcaca ggacgcaaaa 660
gccgagggaa ccgctgacat gttcaatacc ctgaagctgt tgacagtagt gatgtggctg 720
gggtatccaa ttgtgtgggc tcttgagtc gagggtatcg cgggtgtgccc cgttgggggtg 780
acgagctggg gatattcttt cctggatata gtggcaaagt acattttcgc attcttgctc 840
ctgaactata tgacgtcaaa cgaatctgtc gtgtccggca gcattttgga tgttccatct 900
gcttctggga ccccggtga tgatgtgagc aaggcgagg agctgttcac cgggggtggg 960
cccatcctgg tcgagctgga cggcgacgta aacggccaca agttcagcgt gtccggcgag 1020
ggcgagggcg atgccaccta cggcaagctg accctgaagt tcatctgcac caccggcaag 1080
ctgcccgtgc cctggccac cctcgtgacc acctcggct acggcctgca gtgcttcgcc 1140
cgctaccccg accacatgaa gcagcacgac ttcttcaagt ccgccatgcc cgaaggctac 1200
gtccaggagc gcaccatctt cttcaaggac gacggcaact acaagaccg cgcgagggtg 1260
aagttcgagg gcgacaccct ggtgaaccgc atcgagctga agggcatcga cttcaaggag 1320
gacggcaaca tcctggggca caagctggag tacaactaca acagccaca cgtctatata 1380
atggccgaca agcagaagaa cggcatcaag gtgaacttca agatccgcca caacatcgag 1440
gacggcagcg tgcagctcgc cgaccactac cagcagaaca ccccatcgg cgacggcccc 1500
gtgctgctgc ccgacaacca ctacctgagc taccagtccg cctgagcaa agaccccaac 1560
gagaagcgcg atcacatggt cctgctggag ttcgtgaccg ccgccgggat cactctcggc 1620
atggacgagc tgtacaagta a 1641

```

&lt;210&gt; SEQ ID NO 4

&lt;211&gt; LENGTH: 1605

&lt;212&gt; TYPE: DNA

&lt;213&gt; ORGANISM: Artificial Sequence

&lt;220&gt; FEATURE:

```

<223> OTHER INFORMATION: humanized codon optimized sequence from
    Natronomonas pharaonis with the PDZ binding motif ETQZ added to
    the C-terminus

```

&lt;400&gt; SEQUENCE: 4

```

atgacagaga ccctgcctcc cgtgaccgag agtgccgtgg cccttcaagc cgaggttacc 60
caaagggagt tgttcgagtt cgtgctgaac gacccttgc ttgcaagcag tctctatata 120
aacatgcac ttgcaggact gagtatactg ctgttcggtt ttatgaccgg aggactcgat 180
gatccacggg caaaacttat tgctgtgtca accatccttg tgctgtcgt cagcattgcc 240
tcctacactg gattggcgag cggcctgaca atttcgctt ttgaaatgcc agcggggccat 300
ttgcagaag gcagctcagt gatgctggga ggagaagagg tagatggtgt agtcaccatg 360
tggggacggg atctcacctg ggcactttcc acgcccata ttctcctcgc tctgggtctc 420
ctggccggaa gcaatgctac aaagctcttc acagctatca ctttcgatat cgctatgtgc 480
gtgactggcc ttgccgaggc cctgactacc tctcccacc tcatgagatg gttctggtag 540
gctatcagtt gtgcatgctt tctgggtggtc ttgtatatcc tgctgggtgga gtgggacag 600
gacgcaaaag ccgagggaac cgctgacatg ttcaataccc tgaagctgtt gacagtagtg 660
atgtggctgg ggtatccaat tgtgtgggct cttggagtcg agggatcgc ggtgttgccc 720

```

-continued

---

```

gttggggtga cgagctggg atattctttc ctggatatcg tggcaaagta cattttcgca 780
ttcttgctcc tgaactatct gacgtcaaac gaatctgtcg tgtccggcag cattttggat 840
gttccatctg cttctgggac cccggctgat gatatggtga gcaagggcga ggagctgttc 900
accgggggtgg tgcccatcct ggtcgagctg gacggcgacg taaacggcca caagttcagc 960
gtgtccggcg agggcgaggg cgatgccacc tacggcaagc tgaccctgaa gttcatctgc 1020
accaccggca agctgcccgt gccctggccc accctcgtga ccaccttcgg ctacggcctg 1080
cagtgtctcg cccgctaccg cgaccacatg aagcagcagc acttcttcaa gtccgcatg 1140
cccgaaggct acgtccagga gcgcaccatc ttcttcaagg acgacggcaa ctacaagacc 1200
cgcccgaggg tgaagttcga gggcgacacc ctggtgaacc gcatcgagct gaagggcatc 1260
gacttcaagg aggacggcaa catcctgggg cacaagctgg agtacaacta caacagccac 1320
aacgtctata tcatggccga caagcagaag aacggcatca aggtgaactt caagatccgc 1380
cacaacatcg aggacggcag cgtgcagctc gccgaccact accagcagaa caccctcctc 1440
ggcgacggcc ccgtgctgct gcccgacaac cactacctga gctaccagtc cgccctgagc 1500
aaagaccca acgagaagcg cgatcacatg gtctgctgg agttcgtgac cgccgcccggg 1560
atcactctcg gcatggacga gctgtacaag gagaccagg tgtaa 1605

```

&lt;210&gt; SEQ ID NO 5

&lt;211&gt; LENGTH: 1611

&lt;212&gt; TYPE: DNA

&lt;213&gt; ORGANISM: Artificial Sequence

&lt;220&gt; FEATURE:

```

<223> OTHER INFORMATION: humanized codon optimized sequence from
    Natronomonas pharaonis with the PTPP sequence added to the
    C-terminus to promote interaction with actin-binding protein
    filamin

```

&lt;400&gt; SEQUENCE: 5

```

atgacagaga ccctgcctcc cgtgaccgag agtgccgtgg cccttcaagc cgaggttacc 60
caaagggagt tgttcgagtt cgtgctgaac gaccctttgc ttgcaagcag tctctatctc 120
aacatcgcac ttgcaggact gagtatactg ctgttcggtt ttatgaccgg aggactcgat 180
gatccacggg caaaacttat tgctgtgtca accatccttg tgccctgctg cagcattgcc 240
tcctacactg gattggcgag cggcctgaca atttccgttc ttgaaatgcc agcggggccat 300
tttgcagaag gcagctcagt gatgctggga ggagaagagg tagatggtgt agtcaccatg 360
tggggacggg atctcacctg ggcactttcc acgcccataa ttctcctcgc tctgggtctc 420
ctggccggaa gcaatgctac aaagctcttc acagctatca ctttcgatat cgctatgtgc 480
gtgactggcc ttgccgcgcc cctgactacc tcctcccacc tcatgagatg gttctggtac 540
gctatcagtt gtgcatgctt tctgggtggc ttgtatatcc tgctggtgga gtgggcacag 600
gacgccaag cgcgaggaac cgctgacatg ttcaataccc tgaagctgtt gacagtagtg 660
atgtggctgg ggtatccaat tgtgtgggct cttggagctg agggatcgc ggtgttgccc 720
gttggggtga cgagctggg atattctttc ctggatatcg tggcaaagta cattttcgca 780
ttcttgctcc tgaactatct gacgtcaaac gaatctgtcg tgtccggcag cattttggat 840
gttccatctg cttctgggac cccggctgat gatgcggccg ccgtgagcaa gggcgaggag 900
ctgttcaccg ggggtggtgcc catcctggtc gagctggacg gcgacgtaaa cggccacaag 960
ttcagcgtgt ccggcgaggg cgagggcgat gccacctacg gcaagctgac cctgaagtcc 1020

```

-continued

---

```

atctgcacca cggcaagct gcccgtgccc tggcccaccc tcgtgaccac cttcgggtac 1080
ggcctgcagt gcttcgcccg ctaccccgac cacatgaagc agcacgactt cttcaagtcc 1140
gcatgcccg aaggctacgt ccaggagcgc accatcttct tcaaggacga cggcaactac 1200
aagaccgcg cggaggtgaa gttcgagggc gacaccctgg tgaaccgcat cgagctgaag 1260
ggcatcgact tcaaggagga cggcaacatc ctggggcaca agctggagta caactacaac 1320
agccacaacg tctatatcat ggccgacaag cagaagaacg gcatcaaggt gaacttcaag 1380
atccgccaca acatcgagga cggcagcgtg cagctcgccg accactacca gcagaacacc 1440
cccatcggcg acggccccgt gctgctgccc gacaaccact acctgagcta ccagtccgcc 1500
ctgagcaaag accccaacga gaagcgcgat cacatggtcc tgctggagtt cgtgaccgcc 1560
gccgggatca ctctcgcat ggacgagctg tacaagccga ccccgccgta a 1611

```

&lt;210&gt; SEQ ID NO 6

&lt;211&gt; LENGTH: 1605

&lt;212&gt; TYPE: DNA

&lt;213&gt; ORGANISM: Artificial Sequence

&lt;220&gt; FEATURE:

```

<223> OTHER INFORMATION: humanized codon optimized sequence from
    Natronomonas pharaonis with the ER export signal added to the
    C-terminus

```

&lt;400&gt; SEQUENCE: 6

```

atgacagaga ccctgcctcc cgtgaccgag agtgccgtgg cccttcaagc cgaggttacc 60
caaagggagt tgttcgagtt cgtgctgaac gaccctttgc ttgcaagcag tctctatatac 120
aacatcgcac ttgcaggact gagtatactg ctgttcgttt ttatgaccgc aggactcgat 180
gatccacggg caaaacttat tgctgtgtca accatccttg tgctgtcgt cagcattgcc 240
tcctacactg gattggcgag cggcctgaca atttccgttc ttgaaatgcc agcggggccat 300
tttgagaag gcagctcagt gatgctggga ggagaagagg tagatggtgt agtcaccatg 360
tggggacggg atctcacctg ggcactttcc acgcccata ttctcctcgc tctgggtctc 420
ctggccggaa gcaatgctac aaagctcttc acagctatca ctttcgatat cgctatgtgc 480
gtgactggcc ttgccgcggc cctgactacc tcctcccacc tcatgagatg gttctggtac 540
gctatcagtt gtgcatgctt tctgggtggc ttgtatatcc tgctggtgga gtgggcacag 600
gacgccaag ccgcgggaac cgctgacatg ttcaataccc tgaagctgtt gacagtagtg 660
atgtggctgg ggtatccaat tgtgtgggct cttggagtcg agggatcgc ggtgttgcce 720
gttgggggta cgagctgggg atattctttc ctggatatcg tggcaaagta cattttcgca 780
ttcttgctcc tgaactatct gacgtcaaac gaatctgtcg tgtccggcag cattttggat 840
gttccatctg cttctgggac cccggctgat gatgtgagca agggcgagga gctgttcacc 900
ggggtggtgc ccatcctggt cgagctggac ggcgacgtaa acggccaca gttcagcgtg 960
tccggcgagg gcgagggcga tgccacctac ggcaagctga ccctgaagtt catctgcacc 1020
accggcaagc tgcccgtgcc ctggcccacc ctctgacca ccttcggcta cggcctgcag 1080
tgcttcgccc gctaccccga ccacatgaag cagcacgact tcttcaagtc cgccatgccc 1140
gaaggctacg tccaggagcg caccatcttc ttcaaggacg acggcaacta caagaccgcg 1200
gccgaggtga agttcgaggg cgacaccctg gtgaaccgca tcgagctgaa gggcatcgac 1260
ttcaaggagg acggcaacat cctggggcac aagctggagt acaactaaa cagccacaac 1320

```

-continued

---

```

gtctatatca tggccgacaa gcagaagaac ggcataagg tgaacttcaa gatccgccac 1380
aacatcgagg acggcagcgt gcagctcgcc gaccactacc agcagaacac ccccatcggc 1440
gacggccccg tgctgctgcc cgacaaccac tacctgagct accagtccgc cctgagcaaa 1500
gacccccaacg agaagcgcga tcacatggtc ctgctggagt tcgtgaccgc cgccgggatc 1560
actctcggca tggacgagct gtacaagggt ctgggcagcc tgtaa 1605

```

&lt;210&gt; SEQ ID NO 7

&lt;211&gt; LENGTH: 1644

&lt;212&gt; TYPE: DNA

&lt;213&gt; ORGANISM: Artificial Sequence

&lt;220&gt; FEATURE:

```

<223> OTHER INFORMATION: humanized codon optimized sequence from
    Natronomonas pharaonis with a signal peptide (first 15aa) from
    Chr2 (derived from Chlamydomonas reinhardtii) is added to the
    N-terminus

```

&lt;400&gt; SEQUENCE: 7

```

atggattatg gaggcgcctt gagtgccgtt gggcgcgagc tgctatttac agagaccctg 60
cctcccgtga ccgagagtgc cgtggccctt caagccgagg ttacccaaag ggagttgttc 120
gagttcgtgc tgaacgacc tttgcttgca agcagtctct atatcaacat cgcacttgca 180
ggactgagta tactgctggt cgtttttatg acccgaggac tcgatgatcc acgggcaaaa 240
cttattgctg tgtcaaccat ccttgtgcct gtcgtcagca ttgcctccta cactggattg 300
gcgagcggcc tgacaatttc cgttcttgaa atgccagcgg gccattttgc agaaggcagc 360
tcagtgatgc tgggaggaga agaggtagat ggtgtagtca ccatgtgggg acggtatctc 420
acctgggcac tttccacgcc catgattctc ctgcctctgg gtctcctggc cggaagcaat 480
gctacaaagc tcttcacagc taccactttc gatatcgcta tgtgcgtgac tggccttgcc 540
gcgccctga ctacctctc ccacctcatg agatggttct ggtacgctat cagttgtgca 600
tgctttctgg tggctctgta taccctgctg gtggagtggg cacaggacgc caaagccgcg 660
ggaaccgctg acatgttcaa taccctgaag ctggtgacag tagtgatgtg gctgggggat 720
ccaattgtgt gggctcttgg agtcgagggt atcgcgggtg tgcccgttgg ggtgacgagc 780
tggggatatt ctttcttgg taccctgctg aagtagcttt tcgcattctt gctcctgaac 840
tatctgacgt caaacgaatc tgtcgtgtcc ggcagcattt tggatgttcc atctgcttct 900
gggaccccgg ctgatgatgc ggccgcccgt agcaagggcg aggagctgtt caccgggggtg 960
gtgcccattc tggctgagct ggacggcgac gtaaacggcc acaagttcag cgtgtccggc 1020
gagggcgagg gcgatgccac ctacggcaag ctgaccctga agttcatctg caccaccggc 1080
aagctgcccg tgccctggcc caccctctgt accacctctg gctacggcct gcagtgtctc 1140
gcccgtacc ccgaccacat gaagcagcac gacttcttca agtccgcat gccgaaggc 1200
tacgtccagg agcgcaccat cttcttcaag gacgacggca actacaagac ccgcccggag 1260
gtgaagtctg agggcgacac cctggtgaac cgcacgagc tgaaggcat cgacttcaag 1320
gaggacggca acatcctggg gcacaagctg gactacaact acaacagcca caacgtctat 1380
atcatggccg acaagcagaa gaacggcatc aaggtgaact tcaagatccg ccacaacatc 1440
gaggacggca gcgtgcagct cgccgaccac taccagcaga acacccccat cggcgacggc 1500
cccgtgctgc tgcccgacaa ccaactacct agctaccagt ccgcccgtgag caaagacccc 1560

```

-continued

---

```

aacgagaagc gcgatcacat ggtcctgctg gagttcgtga ccgcccggcgg gatcactctc 1620
ggcatggacg agctgtacaa gtaa 1644

```

```

<210> SEQ ID NO 8
<211> LENGTH: 1665
<212> TYPE: DNA
<213> ORGANISM: Artificial Sequence
<220> FEATURE:
<223> OTHER INFORMATION: humanized codon optimized sequence from
    Natronomonas pharaonis with a signal peptide (23aa) from nicotinic
    acetylcholine receptor is added to the N-terminus

```

```

<400> SEQUENCE: 8

```

```

atgggtcttc gtgctcttat gctttggctt cttgctgctg ctggctcttgt tctgtaactc 60
cttcaaggta cagagaccct gcctcccgtg accgagagtg ccgtggccct tcaagccgag 120
gttaccctaaa gggagttgtt cgagttcgtg ctgaacgacc ctttgcttgc aagcagtctc 180
tatatcaaca tcgcacttgc aggactgagt atactgctgt tcgtttttat gaccgagga 240
ctcgatgata cacgggcaaa acttattgct gtgtcaacca tccttgtgcc tgcgctcagc 300
attgcctcct aactggatt ggcgagcggc ctgacaattt ccgttcttga aatgccagcg 360
ggccatcttg cagaaggcag ctcaagtatg ctgggaggag aagaggtaga tgggtgtagc 420
accatgtggg gacggtatct cacctgggca ctttccacgc ccatgattct cctcgctctg 480
ggtctcctgg ccggaagcaa tgctacaaag ctcttcacag ctatcacttt cgatatcgct 540
atgtgcgtga ctggccttgc cgcggccctg actacctcct cccacctcat gagatggttc 600
tggtacgcta tcagttgtgc atgctttctg gtggctcttgt atatcctgct ggtggagtgg 660
gcacaggacg ccaaagccgc gggaaccgct gacatgttca atacctgaa gctggtgaca 720
gtagtgatgt ggctggggta tccaattgtg tgggctcttg gagtcgaggg taccgcggtg 780
ttgcccggtg ggggtgacgag ctggggatat tctttcctgg atatcgtggc aaagtacatt 840
ttcgcattct tgctcctgaa ctatctgacg tcaaacgaat ctgtcgtgtc cggcagcatt 900
ttggatgttc catctgcttc tgggaccccc gctgatgatg cggccgcccgt gagcaagggc 960
gaggagctgt tcaccggggg ggtgcccata ctggctcgagc tggacggcga cgtaaacggc 1020
cacaagttca gcgtgtccgg cgagggcgag ggcgatgcca cctacggcaa gctgaccctg 1080
aagttcatct gcaccaccgg caagctgccc gtgccctggc ccacctcgt gaccaccttc 1140
ggctacggcc tgcagtgtt cgcctgctac cccgaccaca tgaagcagca cgacttcttc 1200
aagtccgcca tgcctgaagg ctacgtccag gagcgacca tcttcttcaa ggacgacggc 1260
aactacaaga cccgcccga ggtgaagttc gagggcgaca ccctggtgaa ccgcatcgag 1320
ctgaagggca tcgacttcaa ggaggacggc aacatcctgg ggcacaagct ggagtacaac 1380
tacaacagcc acaactcta tatcatggcc gacaagcaga agaacggcat caaggtgaac 1440
ttcaagatcc gccacaacat cgaggacggc agcgtgcagc tcgccacca ctaccagcag 1500
aacaccccca tcggcgacgg ccccgctgtg ctgcccgaca accactacct gagctaccag 1560
tccgccctga gcaaagacc caacgagaag cgcgatcaca tggctcctgct ggagttcgtg 1620
accgcccgg ggatcactct cggcatggac gagctgtaca agtaa 1665

```

```

<210> SEQ ID NO 9
<211> LENGTH: 1605
<212> TYPE: DNA

```

-continued

---

<213> ORGANISM: Artificial Sequence

<220> FEATURE:

<223> OTHER INFORMATION: humanized codon optimized sequence from  
Natronomonas pharaonis with the PDZ binding motif VSNL added to  
the C-terminus

<400> SEQUENCE: 9

```

atgacagaga ccctgectcc cgtgaccgag agtgccgtgg cccttcaagc cgaggttacc    60
caaagggagt tggtcgagtt cgtgctgaac gaccctttgc ttgcaagcag tctctatata    120
aacatcgcac ttgcaggact gagtatactg ctgttcggtt ttatgacctg aggactcgat    180
gatccacggg caaaacttat tgctgtgtca accatccttg tgctgtcgt cagcattgcc    240
tcctacactg gattggcgag cggcctgaca atttcctgta ttgaaatgcc agcggggccat    300
tttgcagaag gcagctcagt gatgctggga ggagaagagg tagatggtgt agtcaccatg    360
tggggacggg atctcacctg ggcactttcc acgcccata tctctctcgc tctgggtctc    420
ctggccggaa gcaatgctac aaagctcttc acagctatca ctttcgatat cgctatgtgc    480
gtgactggcc ttgcccgggc cctgactacc tctcccacc tcatgagatg gttctggtac    540
gctatcagtt gtgcatgctt tctgggtggtc ttgtatatcc tgctggtgga gtgggacacag    600
gacgcccagg ccgcccgaac cgctgacatg ttcaataccc tgaagctgtt gacagtagtg    660
atgtggctgg ggtatccaat tgtgtgggct cttggagtcg agggatcgc ggtgttgccc    720
gttgggggta cgagctgggg atattctttc ctggatatcg tggcaaagta cattttcgca    780
ttcttctccc tgaactatct gacgtcaaac gaatctgtcg tgtccggcag cattttggat    840
gttccatctg cttctgggac cccggctgat gatatggtga gcaagggcga ggagctgttc    900
accgggggtg tgcccattct ggtcgagctg gacggcgagc taaacggcca caagttcagc    960
gtgtccggcg agggcgaggg cgatgccacc tacggcaagc tgaccctgaa gttcatctgc   1020
accaccggca agctgcccgt gccctggccc accctcgtga ccaccttcgg ctaccggcctg   1080
cagtgtctcg cccgctaccg cgaccacatg aagcagcagc acttcttcaa gtccgcatg    1140
cccgaaggct acgtccagga ggcaccatc ttcttcaagg acgacggcaa ctacaagacc   1200
cgcgcccagg tgaagttcga gggcgacacc ctggtgaacc gcatcgagct gaagggcatc   1260
gacttcaagg aggacggcaa catcctgggg cacaagctgg agtacaacta caacagccac   1320
aacgtctata tcatggccga caagcagaag aacggcatca aggtgaactt caagatccgc   1380
cacaacatcg aggacggcag cgtgcagctc gccgaccact accagcagaa ccccccatc   1440
ggcgacggcc ccgtgctgct gcccgacaac cactacctga gctaccagtc cgccctgagc   1500
aaagacccca acgagaagcg cgatcacatg gtctgctggt agttcgtgac cgccgcccggg   1560
atcactctcg gcatggacga gctgtacaag gtgagcaacc tgtaa                      1605

```

<210> SEQ ID NO 10

<211> LENGTH: 1599

<212> TYPE: DNA

<213> ORGANISM: Artificial Sequence

<220> FEATURE:

<223> OTHER INFORMATION: humanized codon optimized sequence from  
Natronomonas pharaonis with a hybrid construct of the ER export  
signal added to the C-terminus and the signal peptide (23aa) from  
nicotinic acetylcholine receptor added to the N-terminus

<400> SEQUENCE: 10

```

atgacagaga ccctgectcc cgtgaccgag agtgccgtgg cccttcaagc cgaggttacc    60

```

-continued

---

caaagggagt	tgttcgagtt	cgtgctgaac	gaccctttgc	ttgcaagcag	tctctatatac	120
aacatcgcac	ttgcaggact	gagtatactg	ctgttcgttt	ttatgacccg	aggactcgat	180
gatccacggg	caaaacttat	tgctgtgtca	accatccttg	tgctgtcgt	cagcattgcc	240
tcctacactg	gattggcgag	cggcctgaca	atttcgcttc	ttgaaatgcc	agcggggccat	300
tttgcagaag	gcagctcagt	gatgctggga	ggagaagagg	tagatggtgt	agtcacccatg	360
tggggacggg	atctcacctg	ggcactttcc	acgcccataga	ttctcctcgc	tctgggtctc	420
ctggccggaa	gcaatgctac	aaagctcttc	acagctatca	ctttcgatat	cgctatgtgc	480
gtgactggcc	ttgccgcggc	cctgactacc	tctcccacc	tcatgagatg	gttctggtag	540
gctatcagtt	gtgcatgctt	tctgggtggc	ttgtatatcc	tgctgggtgga	gtggggcacag	600
gacgcccagg	ccgcggaac	cgctgacatg	ttcaataccc	tgaagctgtt	gacagtagtg	660
atgtggctgg	ggatccaat	tgtgtgggct	cttgagctcg	agggtatcgc	ggtgttgccc	720
gttgggtgga	cgagctgggg	atattctttc	ctggatatcg	tggcaaagta	cattttcgca	780
ttcttctc	tgaactatct	gacgtcaaac	gaatctgtcg	tgtccggcag	cattttggat	840
gttccatctg	cttctgggac	cccggctgat	gatgcggccg	ccgtgagcaa	gggcgaggag	900
ctgttcaccg	gggtggtgcc	catcctggtc	gagctggacg	gcgacgtaa	cggccacaag	960
ttcagcgtgt	ccggcgaggg	cgagggcgat	gccacctacg	gcaagctgac	cctgaagtcc	1020
atctgcacca	ccggcaagct	gcccgtgccc	tggcccaccc	tcgtgaccac	cttcggctac	1080
ggcctgcagt	gcttcgcccg	ctaccccgac	cacatgaagc	agcacgactt	cttcaagtcc	1140
gcatgcccg	aaggctacgt	ccaggagcgc	accatcttct	tcaaggacga	cggcaactac	1200
aagaccgcg	ccgaggtgaa	gttcgagggc	gacaccctgg	tgaaccgcat	cgagctgaag	1260
ggcatcgact	tcaaggagga	cggcaacatc	ctggggcaca	agctggagta	caactacaac	1320
agccacaacg	tctatatcat	ggccgacaag	cagaagaacg	gcatcaaggt	gaacttcaag	1380
atccgccaca	acatcgagga	cggcagcgtg	cagctcgccg	accactacca	gcagaacacc	1440
cccatcggcg	acggccccgt	gctgctgccc	gacaaccact	acctgageta	ccagtccgcc	1500
ctgagcaaag	acccaacga	gaagcgcgat	cacatggtcc	tgctggagtt	cgtgaccgcc	1560
gcccggatca	ctctcgcat	ggacgagctg	tacaagtaa			1599

---

What is claimed is:

1. A method for generating an inhibitory neuron-current flow, the method comprising:

in a neuron, using a NpHR-based molecule that responds to light by producing an inhibitory current to dissuade depolarization of the neuron, wherein a high expression of the molecule manifests a toxicity level that is less than about 75%.

2. The method of claim 1, wherein the molecule is expressed using at least one of the NpHR molecular variants from Table 2, namely, Non-Humanized NpHR, SP<sub>nChR-S</sub>-NpHR, NpHR-ETQV, NpHR-actin, NpHR-ERexport.

3. The method of claim 1, wherein the toxicity is less than about 40%.

4. The method of claim 1, wherein the toxicity is less than about 10%.

5. The method of claim 1, wherein the molecule uses an endogenous cofactor to produce the inhibitory current, and

wherein the inhibitory current substantially dissuades depolarization of the neuron in less than 500 milliseconds after being exposing to light.

6. The method of claim 1, wherein the inhibitory molecule does not have the sequence as set forth in GenBank accession number EF474018 and uses an endogenous cofactor to produce the inhibitory current.

7. The method of claim 1, wherein the step of using a NpHR-based molecule that responds to light by producing an inhibitory current to dissuade depolarization of the neuron, includes using at least two NpHR-based molecular variants.

8. The method of claim 1, wherein the step of using a NpHR-based molecule includes causing the cell to express light-activated NpHR-based molecule and exposing the cell to light to activate the NpHR-based protein.

9. The method of claim 8, wherein the step of causing the cell to express light-activated NpHR-based molecule includes using at least two NpHR-based constructs.

**10.** The method of claim **9**, wherein the two NpHR-based constructs are independently capable of causing the cell to express light-activated NpHR-based protein, wherein the two NpHR-based constructs are either part of the same sequence or independently delivered.

**11.** The method of claim **10**, wherein the step of using an NpHR-based molecule includes using a ChR2-based molecule to control transmission of the neuron.

**12.** A method of optically controlling cell properties, comprising:

causing the cell to express light-activated NpHR-based proteins using at least two NpHR-based molecular variants, each of the variants characterized in being useful for expressing a light-activated NpHR-based molecule that responds to light by producing an inhibitory current to dissuade depolarization of the neuron; and

exposing the cell to light to activate the NpHR-based protein.

**13.** The method of claim **12**, wherein the molecule is expressed using at least one of the NpHR molecular variants from Table 2, namely, Non-Humanized NpHR, SP<sub>nAChR-S</sub>-NpHR, NpHR-ETQV, NpHR-actin, NpHR-ERexport.

**14.** A method of optically controlling cell properties, comprising:

causing the cell to express light-activated NpHR-based protein; and

exposing the cell to light to activate the NpHR-based protein, wherein the NpHR-based molecule is characterized in that a high expression of the molecule manifests a toxicity level that is less than about 75%.

**15.** The method of claim **14**, wherein the NpHR-based molecule is characterized in that the high expression of the molecule corresponds to about  $3 \times 10^7$  infectious units per milliliter.

**16.** A nucleic acid sequence comprising a gene for a light-activated NpHR-based molecule and a promoter, wherein the molecule responds to light by producing an inhibitory current to dissuade depolarization of a neuron, wherein a high expression of the molecule manifests a toxicity level that is less than about 75%.

**17.** The nucleic acid sequence of claim **16**, wherein the molecule uses an endogenous cofactor to produce the inhibitory current, wherein the endogenous cofactor is all-trans-retinal (ATR).

**18.** The method of claim **16**, wherein the inhibitory current substantially dissuades depolarization of the neuron in less than 500 milliseconds after being exposed to light.

**19.** A composition comprising: a light-activated NpHR-based molecule that is expressed in a cell wherein the cell is selected from the group consisting of mammalian cells, neuronal cells and stem cells, wherein a high expression of the molecule manifests a toxicity level that is less than about 75%.

**20.** The composition of claim **19**, wherein the molecule is expressed using at least one of the NpHR molecular variants from Table 2, namely, Non-Humanized NpHR, SP<sub>nAChR-S</sub>-NpHR, NpHR-ETQV, NpHR-actin, NpHR-ERexport.

**21.** A method of controlling synaptic transmissions, comprising:

causing a neuron that ends in a synapse to express light-activated NpHR-based molecules, and

exposing the cell to light to activate the NpHR-based molecules, wherein the step of exposing to light dissuades a synaptic event,

wherein either

a high expression of the molecules manifests a toxicity level that is less than about 75%, or

the light-activated NpHR-based molecules are expressed using at least two NpHR-based molecular variants, each of the variants characterized in being useful for expressing a light-activated NpHR-based molecule that responds to light by producing an inhibitory current to dissuade depolarization of the neuron.

**22.** A vector for delivering a nucleic acid sequence that codes for light-activated NpHR-based molecules and a promoter, wherein either

a high expression of the molecules manifests a toxicity level that is less than about 75%, or

the light-activated NpHR-based molecules are expressed using at least two NpHR-based molecular variants, each of the variants characterized in being useful for expressing a light-activated NpHR-based molecule that responds to light by producing an inhibitory current to dissuade depolarization of the neuron.

**23.** A NpHR-based molecule for use in therapy wherein the molecule is capable of responding to light by producing an inhibitory current to dissuade depolarization of a neuron and wherein the molecule is capable of producing the inhibitory current, and wherein a high expression of the molecule manifests a toxicity level that is less than about 75%.

**24.** A nucleic acid molecule comprising a nucleotide sequence encoding a NpHR based protein for use in the treatment of CNS disorders wherein the protein is capable of responding to light by producing an inhibitory current to dissuade depolarization of a neuron, and wherein a high expression of the molecule manifests a toxicity level that is less than about 75%.

**25.** Use of a NpHR-based molecule in the manufacture of a medicament for the treatment of neurological or CNS disorders wherein the said molecule is capable of responding to light by producing an inhibitory current to dissuade depolarization of a neuron, and wherein a high expression of the molecule manifests a toxicity level that is less than about 75%.

**26.** An assembly or kit of parts, comprising: a product containing an NpHR-based molecular variant and another opsin-based molecule as a combined preparation for use in the treatment of disease of a neurological or CNS disorder, wherein at least the NpHR-based molecular variant is useful for expressing a light-activated NpHR-based molecule that responds to light by producing an inhibitory current to dissuade depolarization of a cell, and wherein a high expression of the molecule manifests a toxicity level that is less than about 75%.

\* \* \* \* \*