



US 20090076536A1

(19) **United States**

(12) **Patent Application Publication**  
**Rentschler et al.**

(10) **Pub. No.: US 2009/0076536 A1**

(43) **Pub. Date: Mar. 19, 2009**

(54) **MEDICAL INFLATION, ATTACHMENT, AND DELIVERY DEVICES AND RELATED METHODS**

(75) Inventors: **Mark Rentschler**, Boulder, CO (US); **Shane M. Farritor**, Lincoln, NE (US)

Correspondence Address:  
**FAEGRE & BENSON LLP**  
**PATENT DOCKETING**  
**2200 WELLS FARGO CENTER, 90 SOUTH SEVENTH STREET**  
**MINNEAPOLIS, MN 55402-3901 (US)**

(73) Assignee: **Board of Regents of the University of Nebraska**, Lincoln, NE (US)

(21) Appl. No.: **12/192,663**

(22) Filed: **Aug. 15, 2008**

**Related U.S. Application Data**

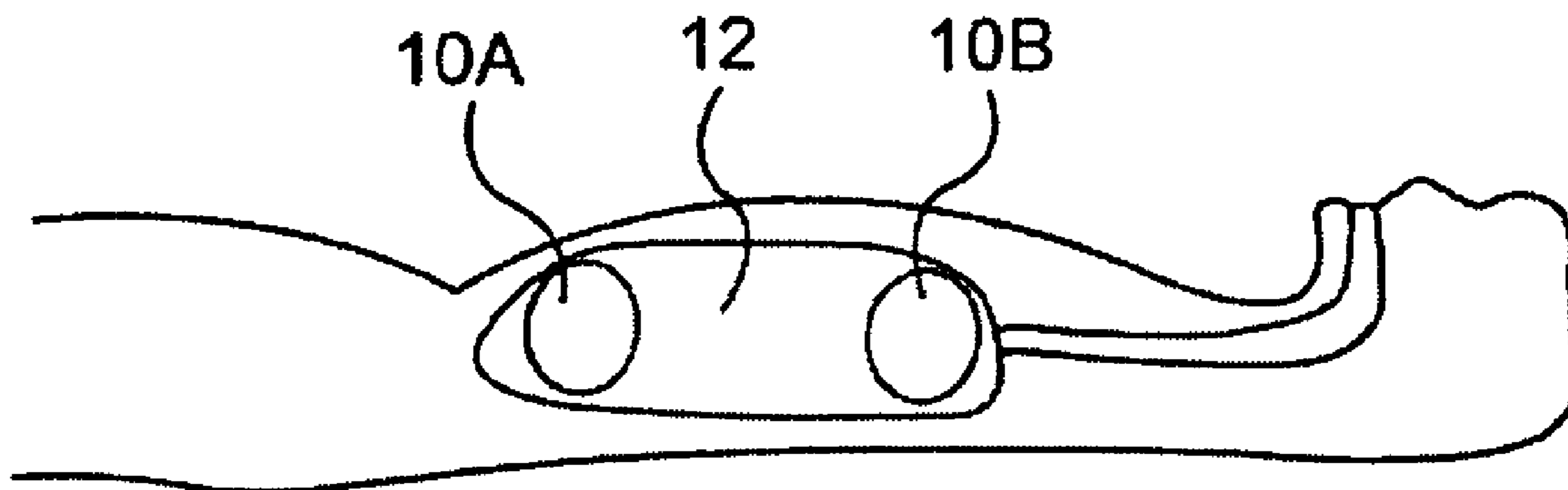
(60) Provisional application No. 60/956,032, filed on Aug. 15, 2007, provisional application No. 60/990,062, filed on Nov. 26, 2007, provisional application No. 60/990,470, filed on Nov. 27, 2007.

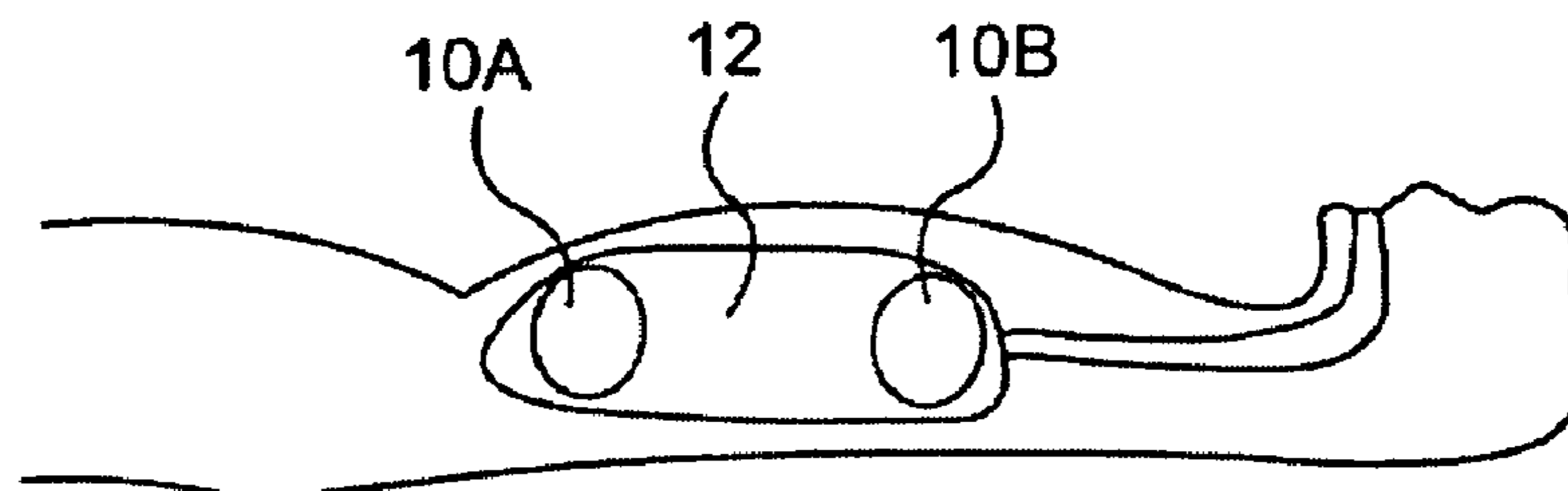
**Publication Classification**

(51) **Int. Cl.**  
*A61M 29/02* (2006.01)  
(52) **U.S. Cl.** ..... **606/192; 606/198**

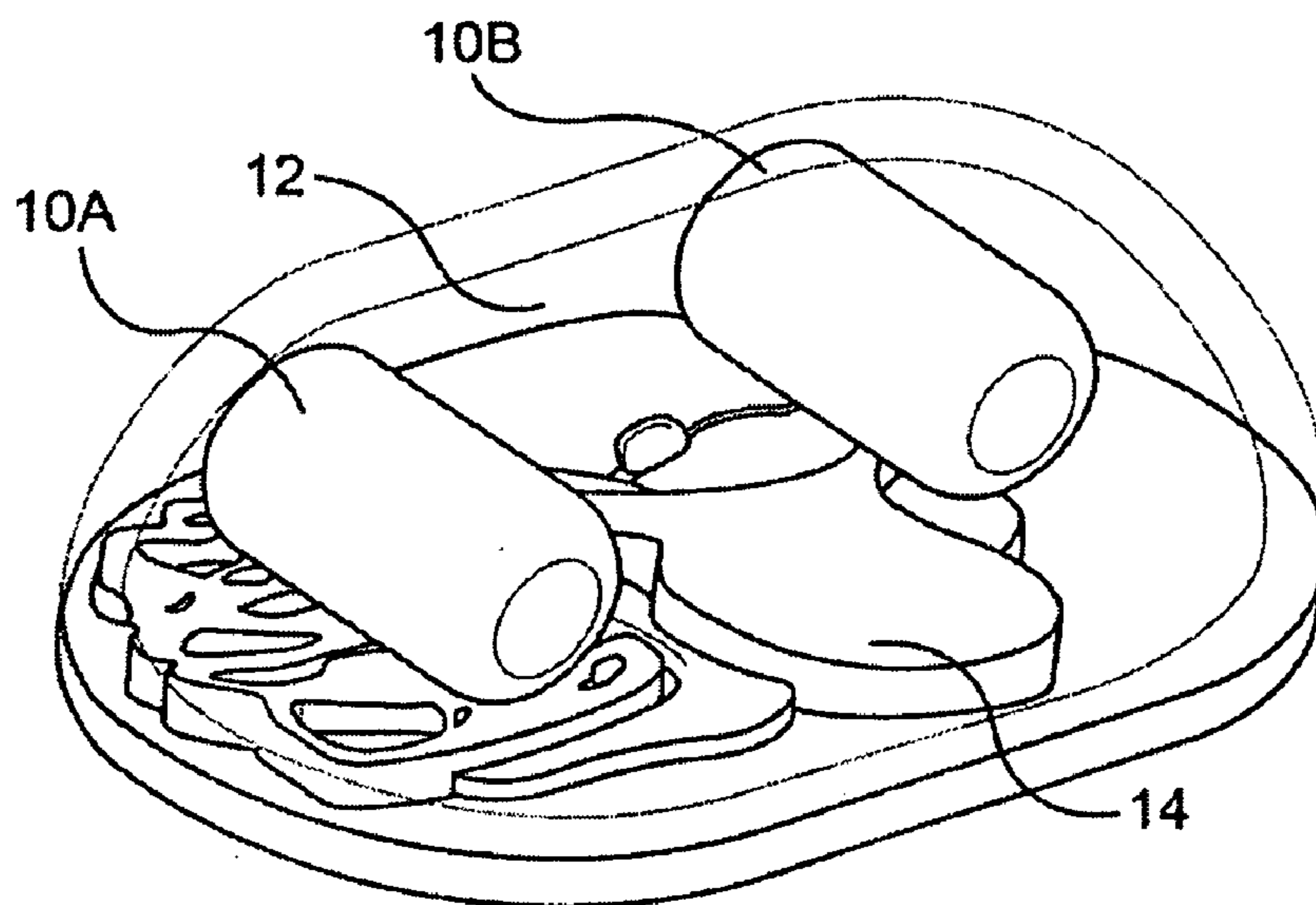
(57) **ABSTRACT**

The various embodiments disclosed herein relate to procedural space maintenance devices, medical device positioning devices, and devices that provide both procedural space maintenance and device positioning. Further embodiments relate to medical device insertion and/or retraction devices.

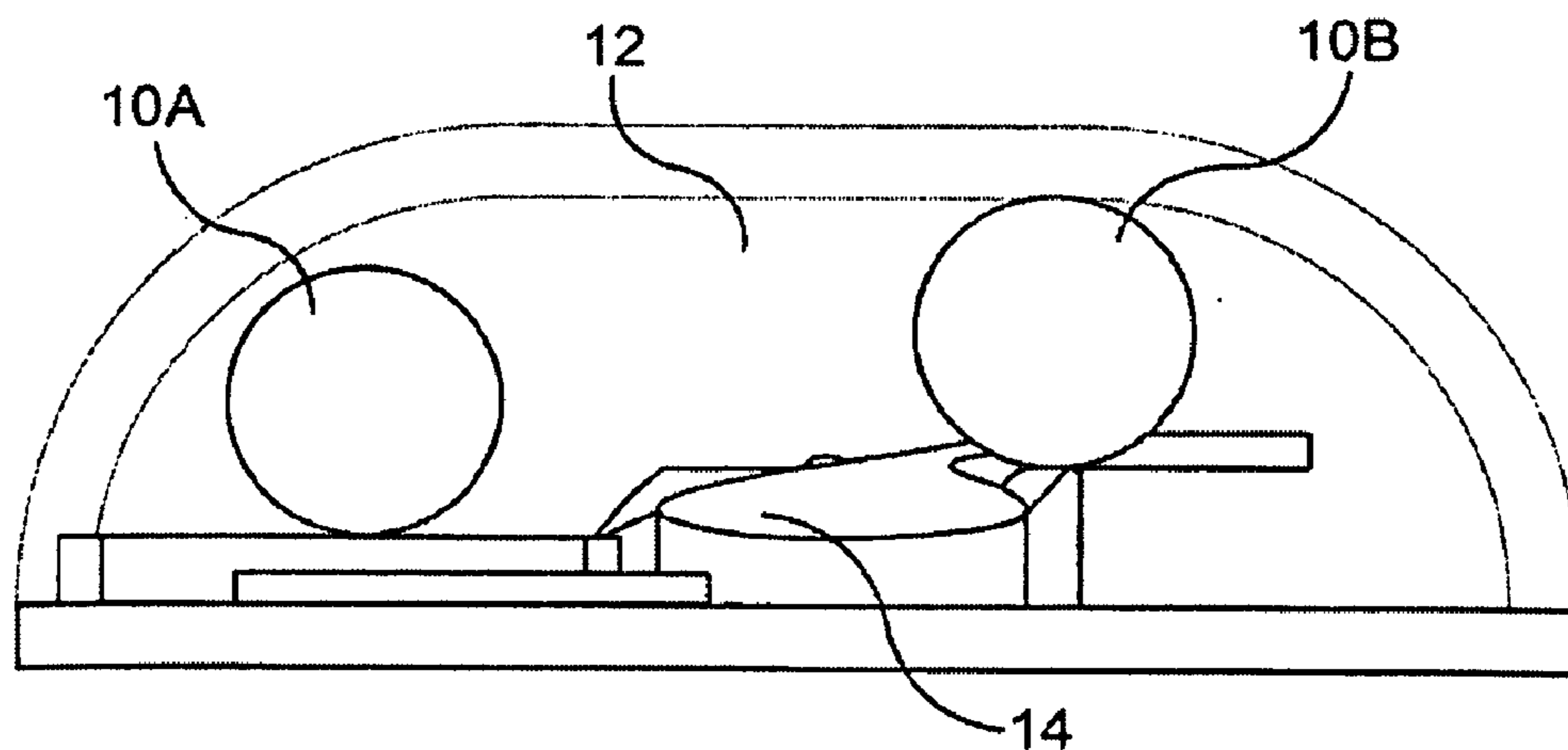




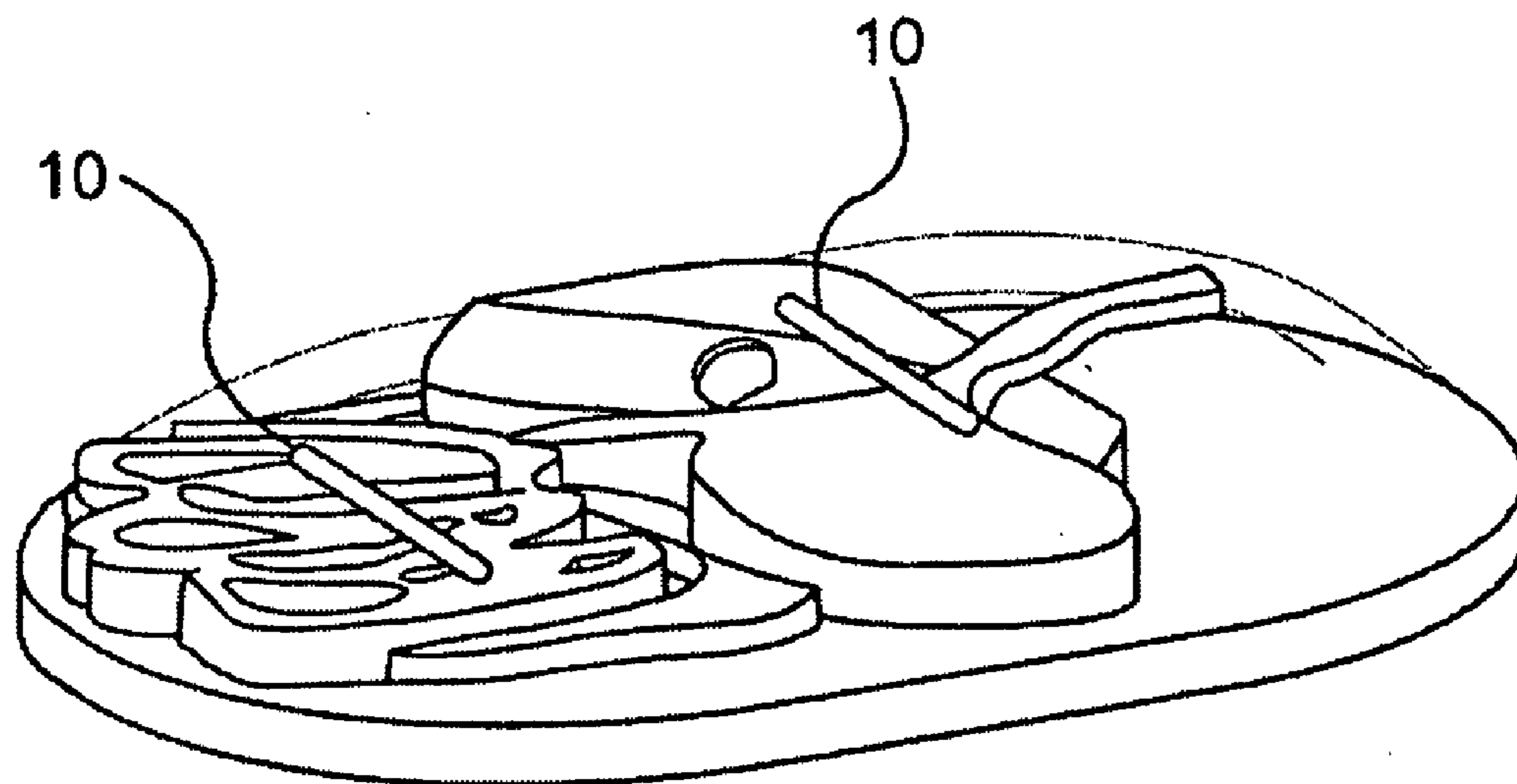
**Fig. 1A**



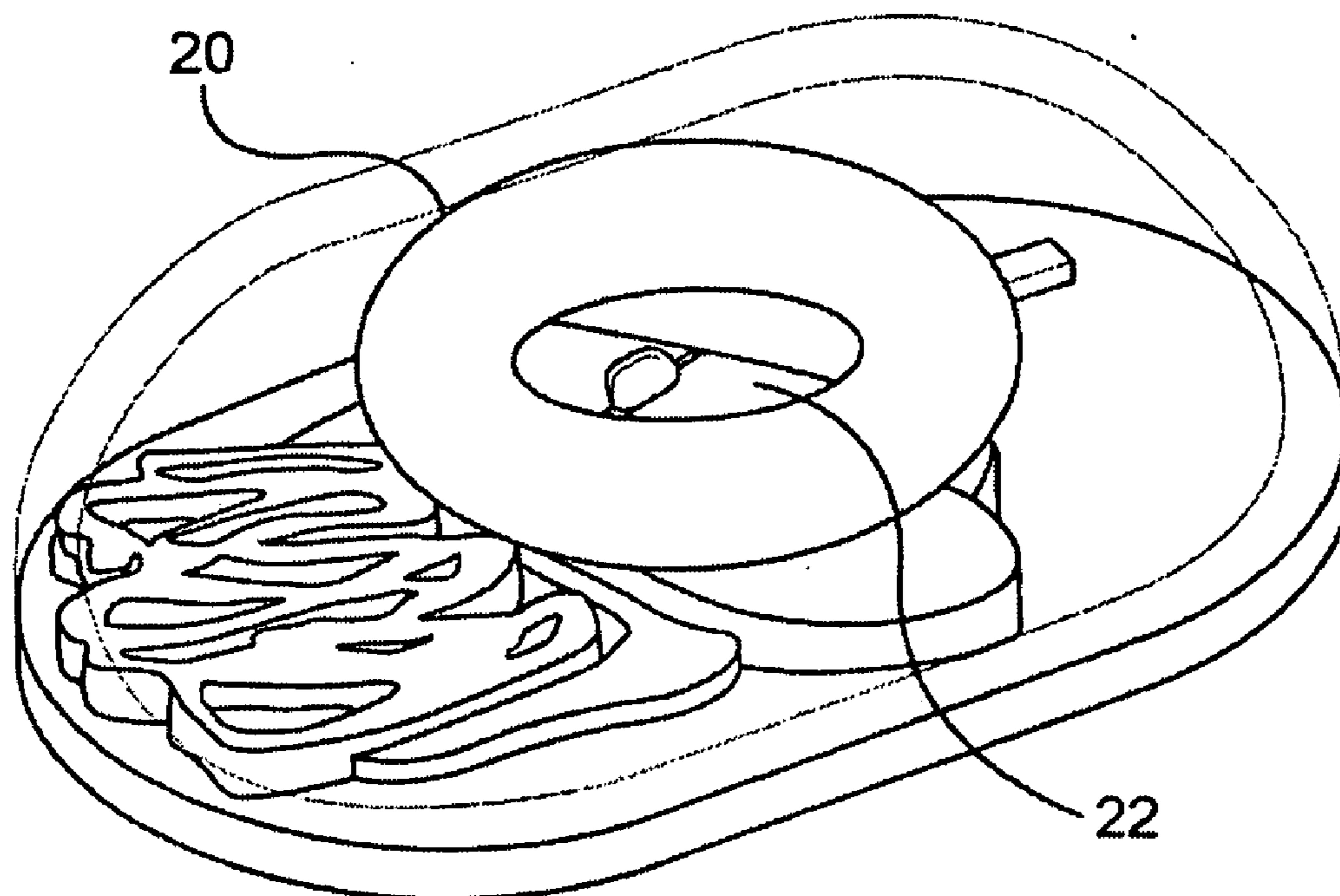
**Fig. 1B**



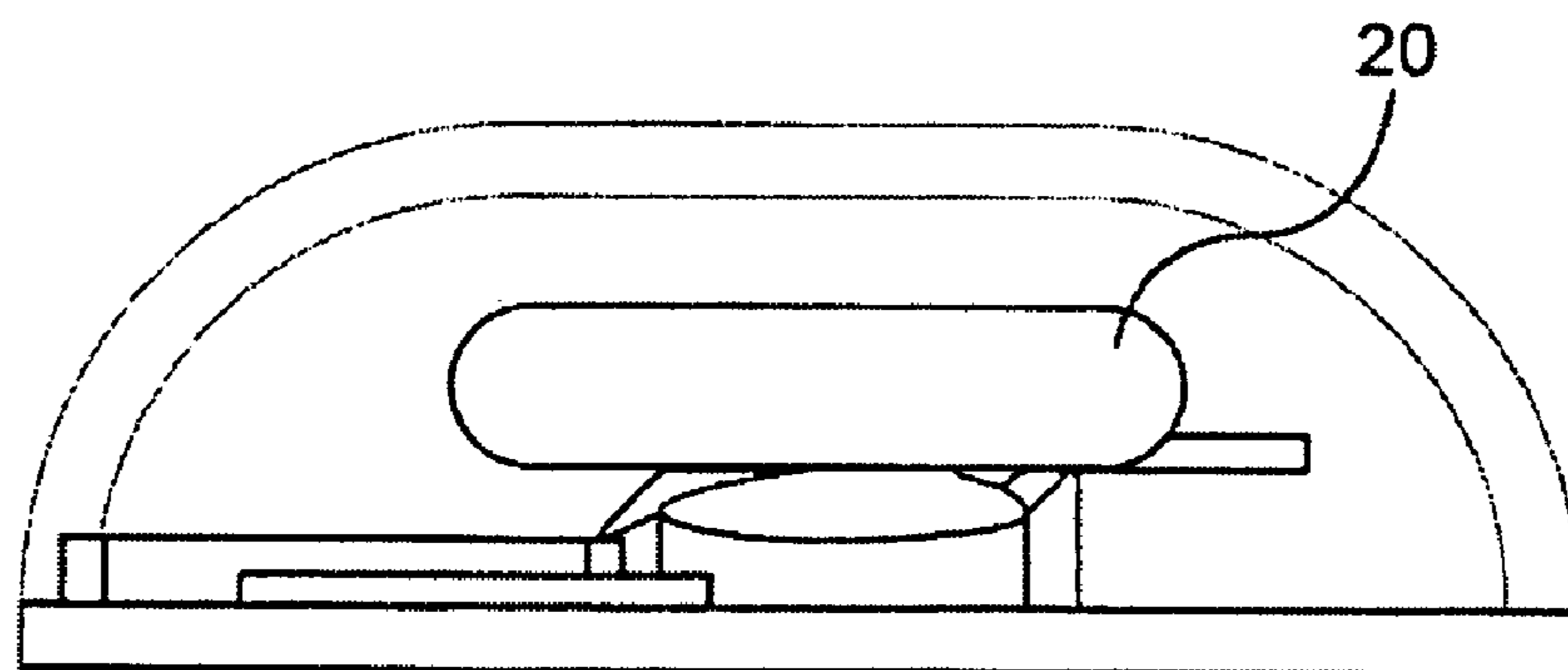
**Fig. 1C**



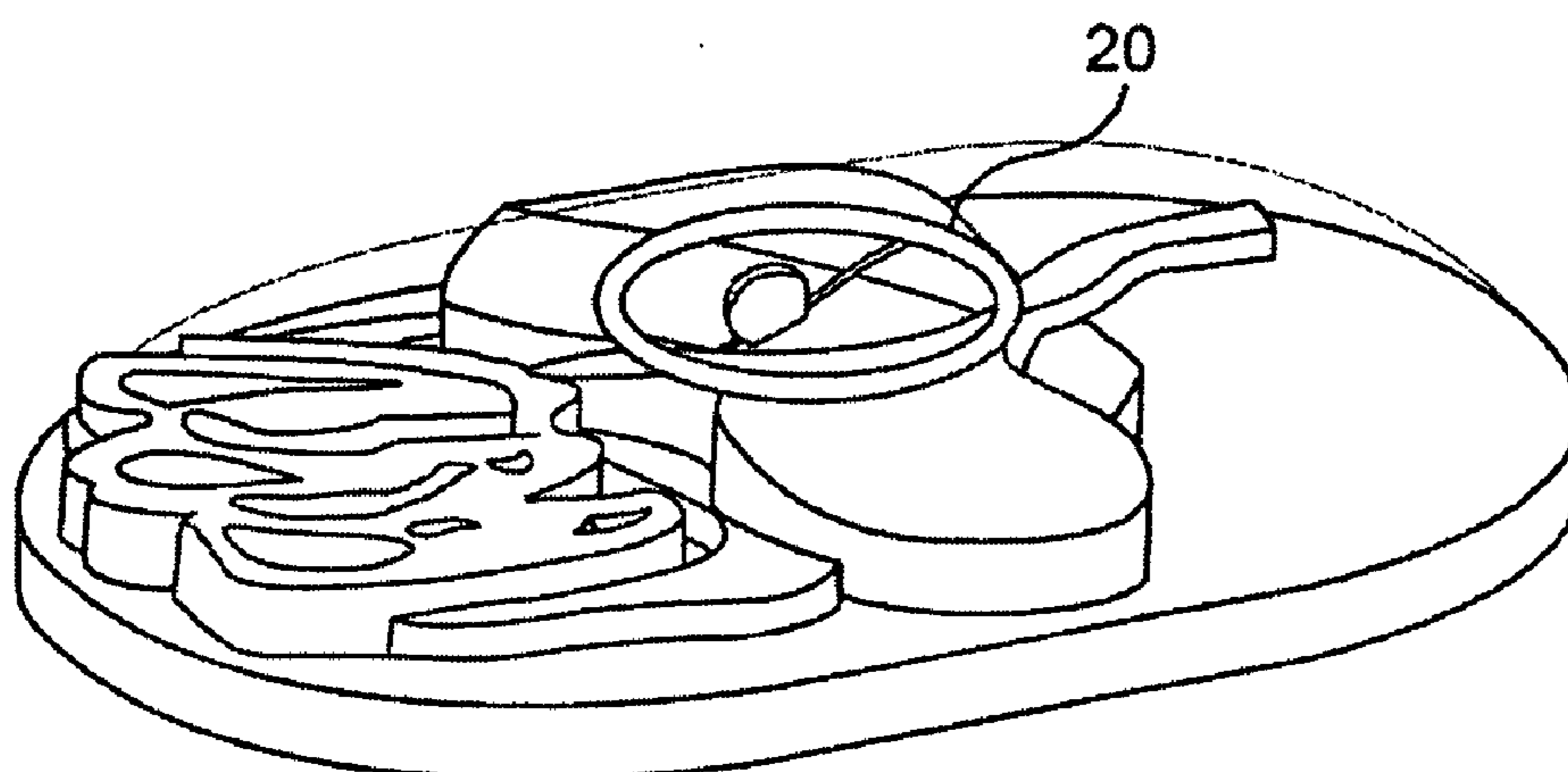
**Fig. 1D**



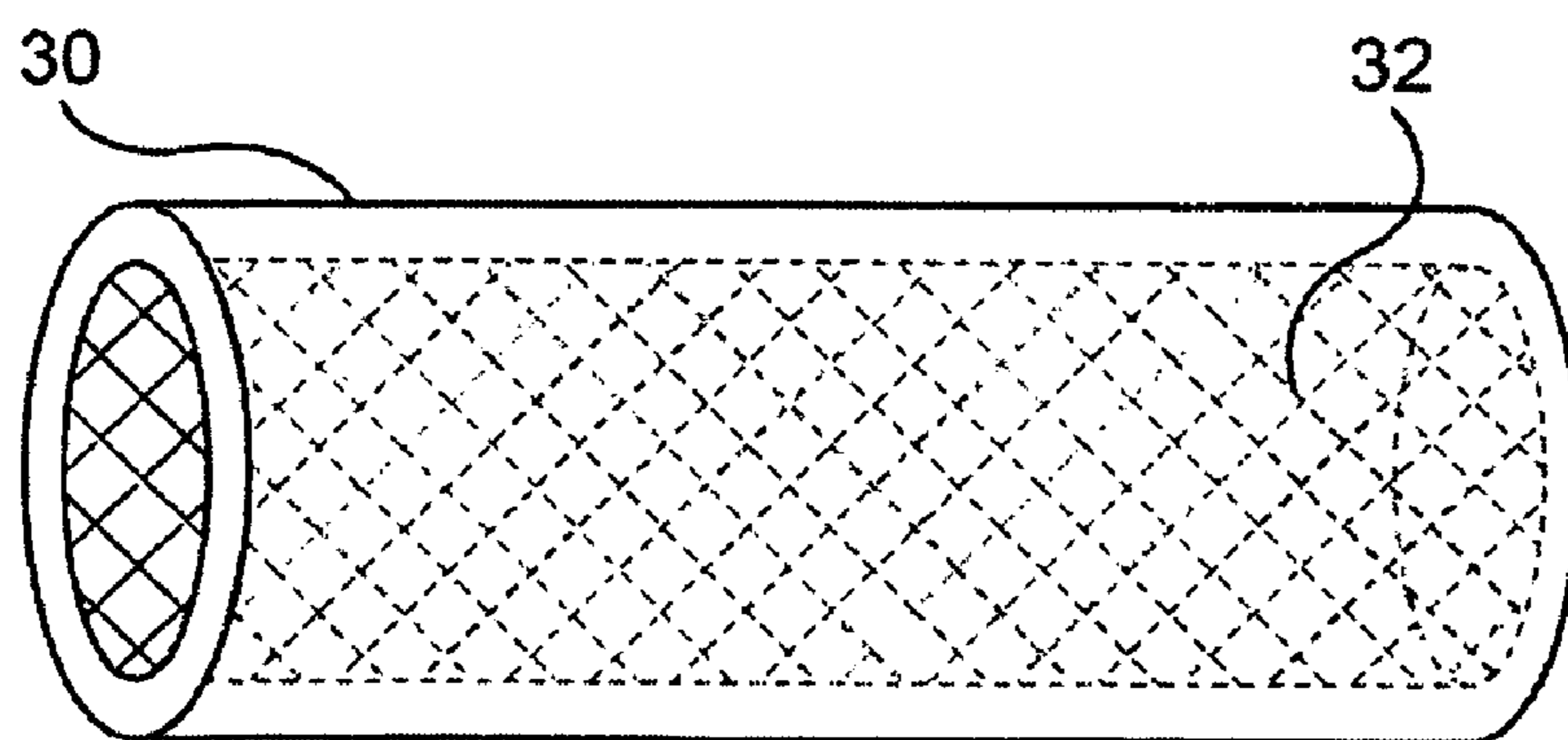
**Fig. 2A**



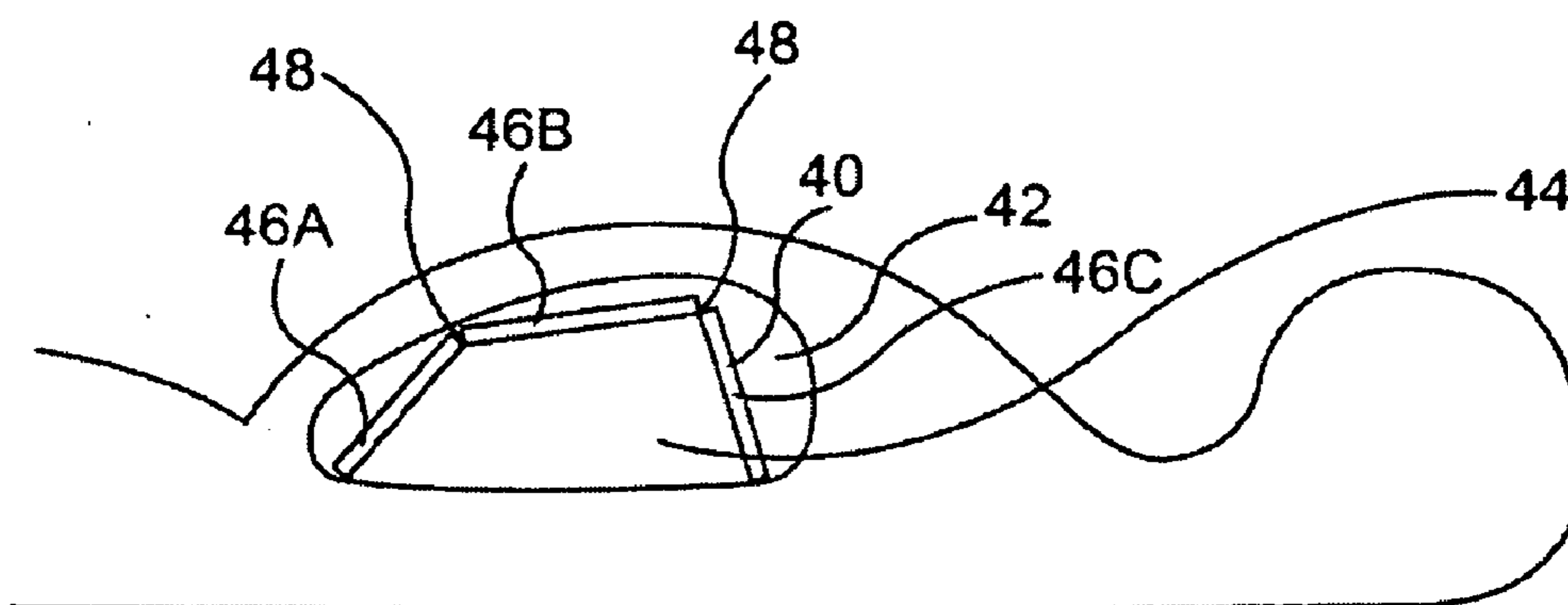
**Fig. 2B**



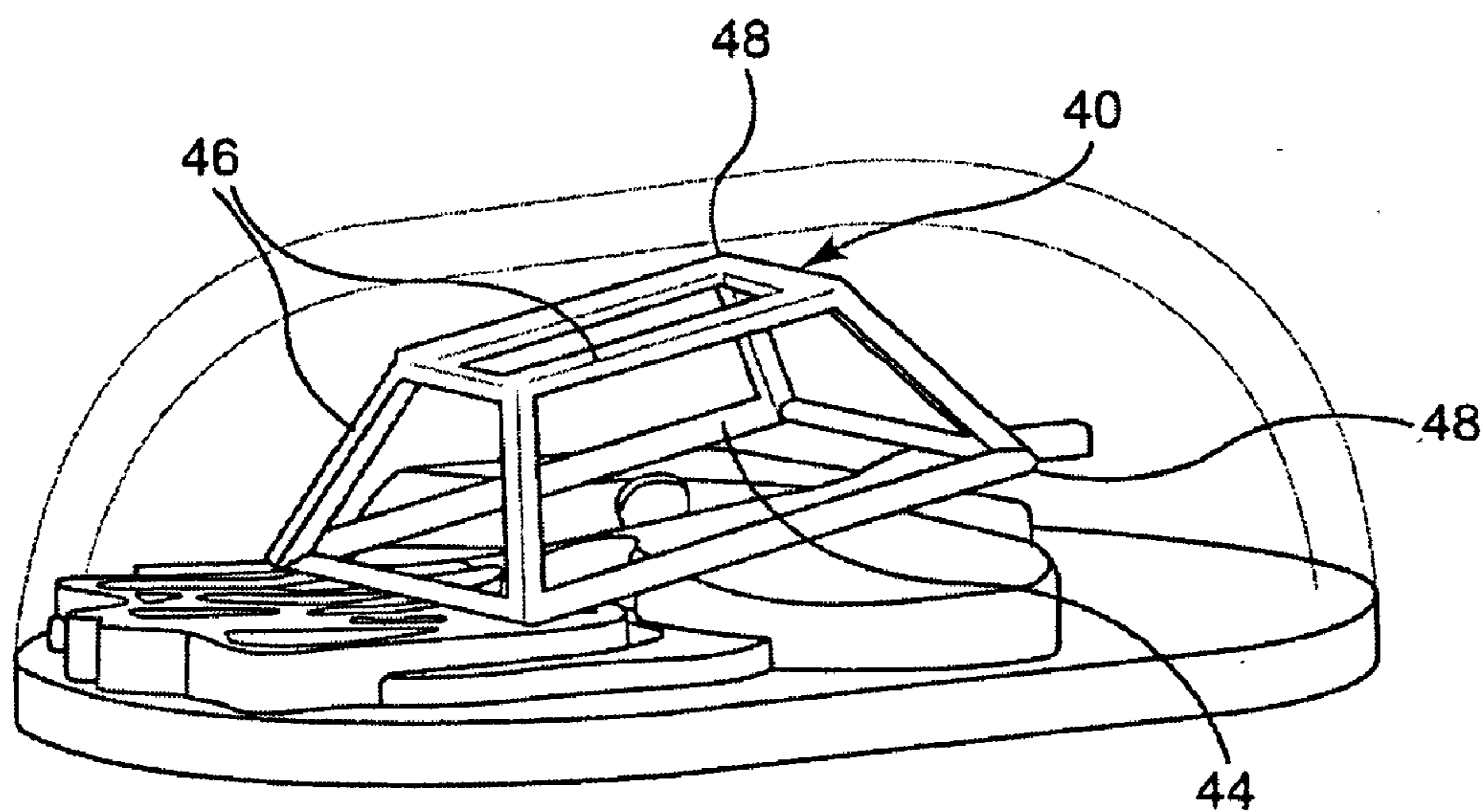
**Fig. 2C**



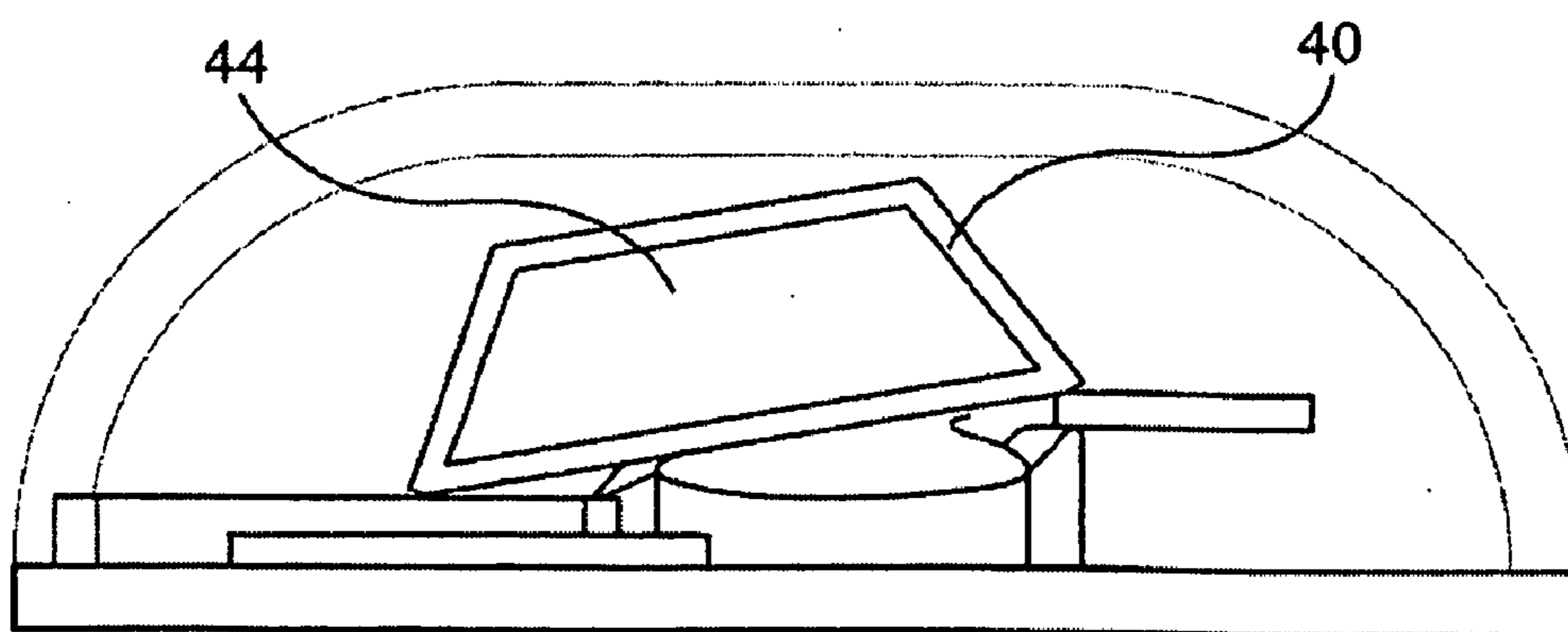
**Fig. 3**



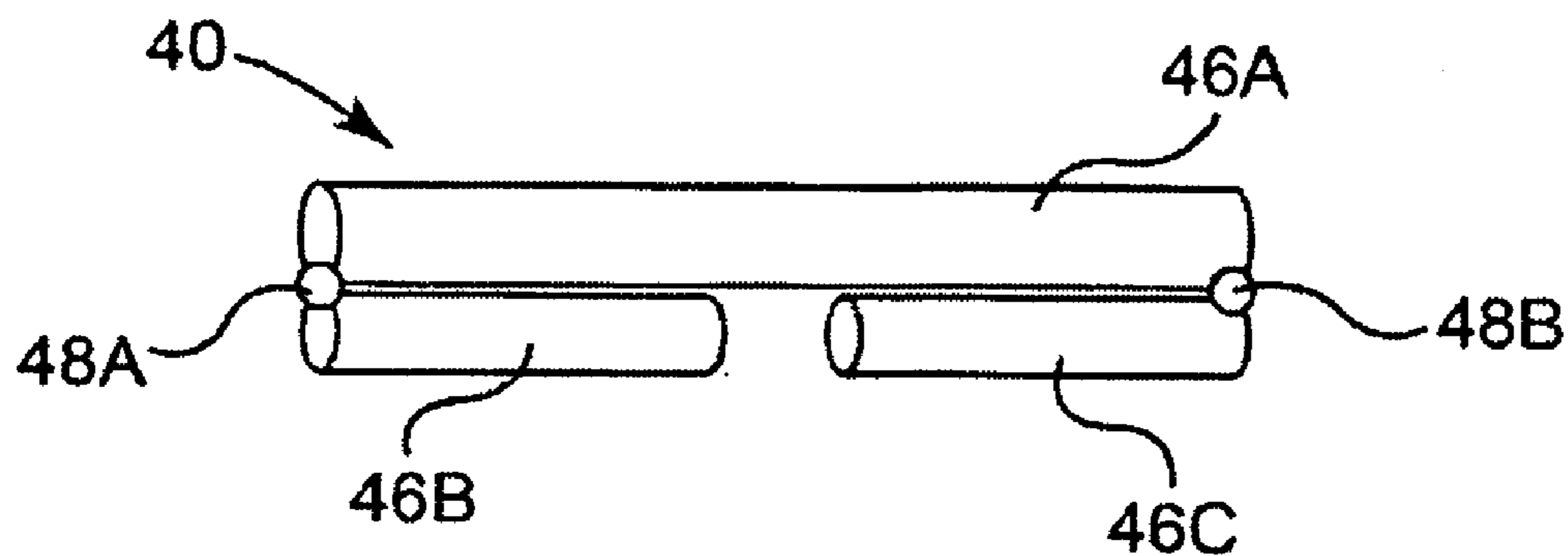
**Fig. 4A**



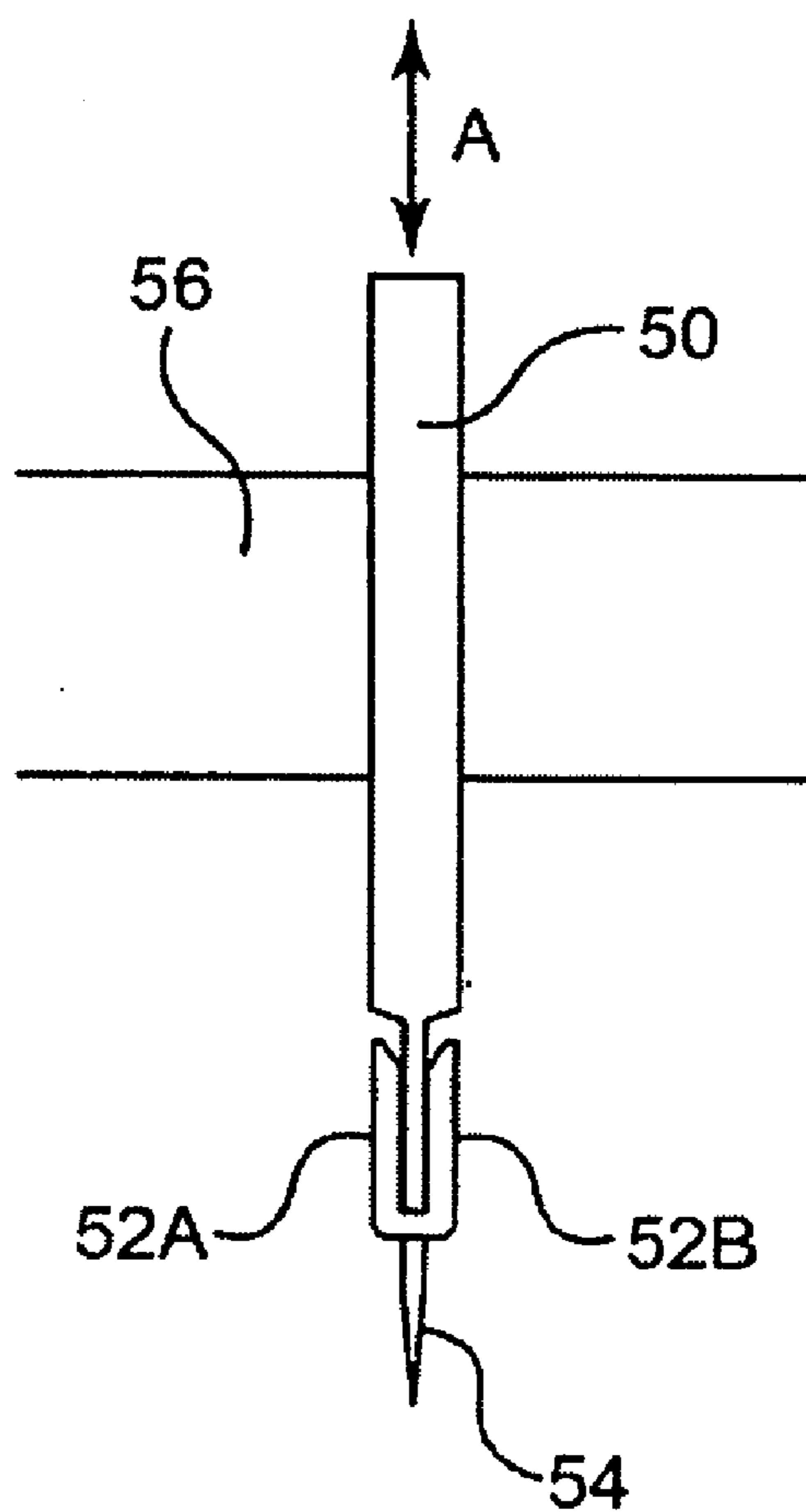
**Fig. 4B**



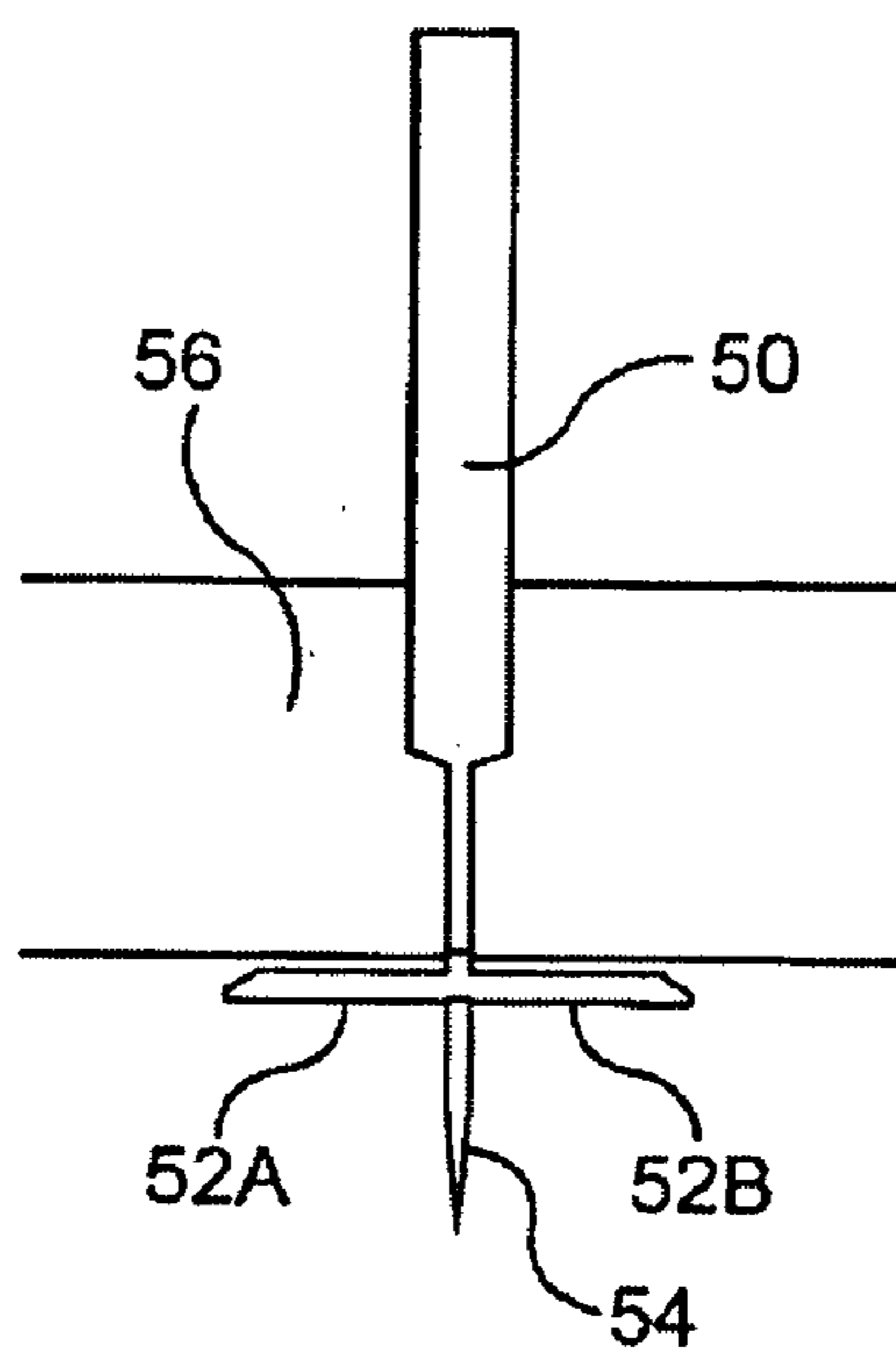
**Fig. 4C**



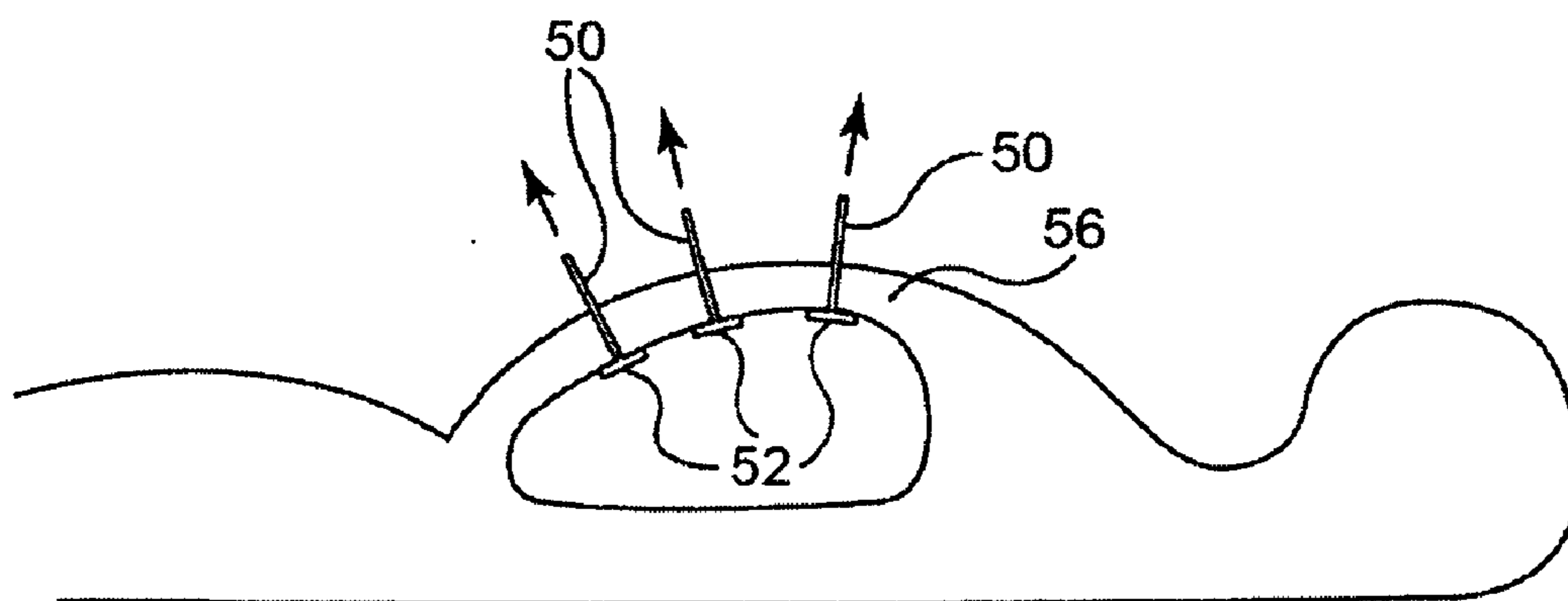
**Fig. 4D**



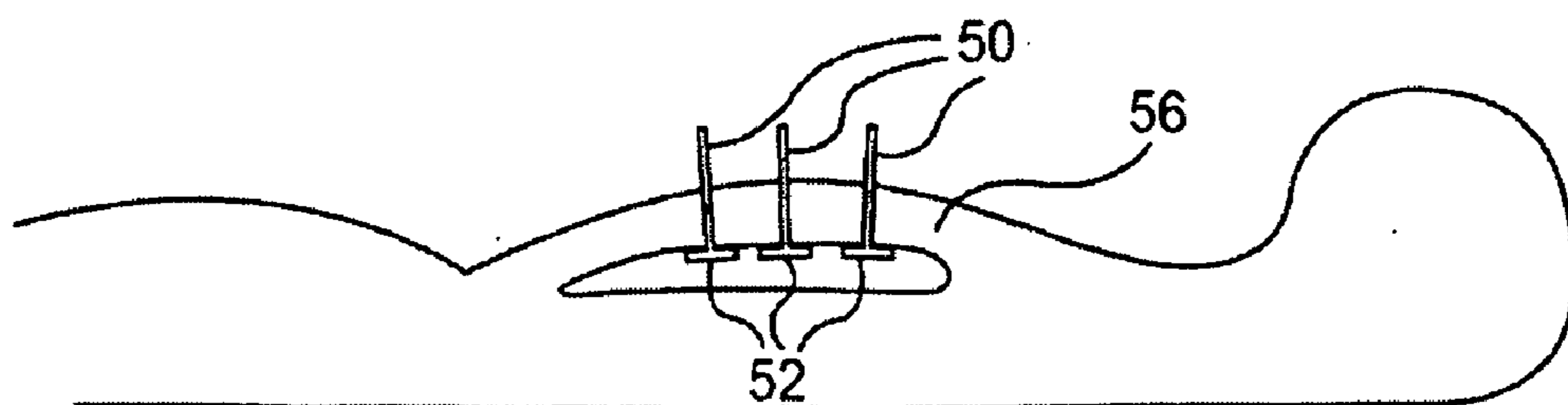
**Fig. 5A**



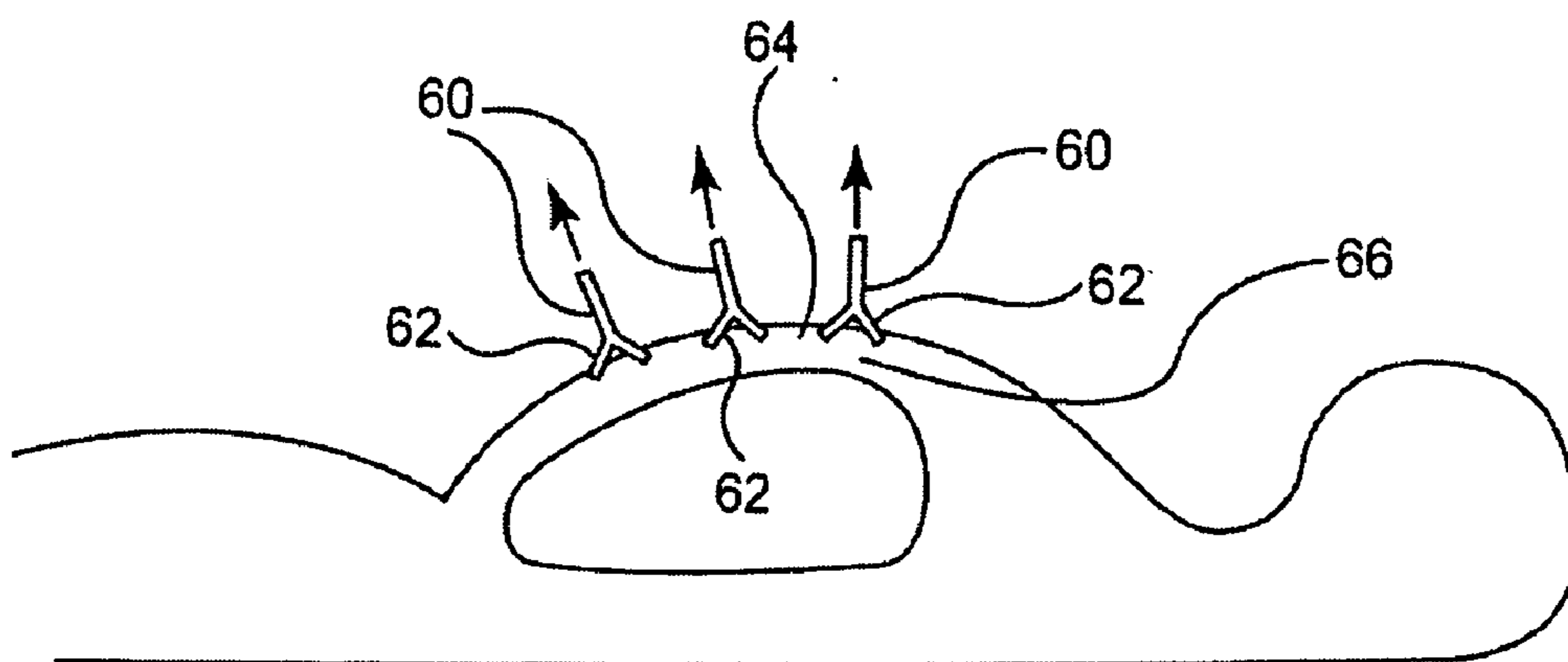
**Fig. 5B**



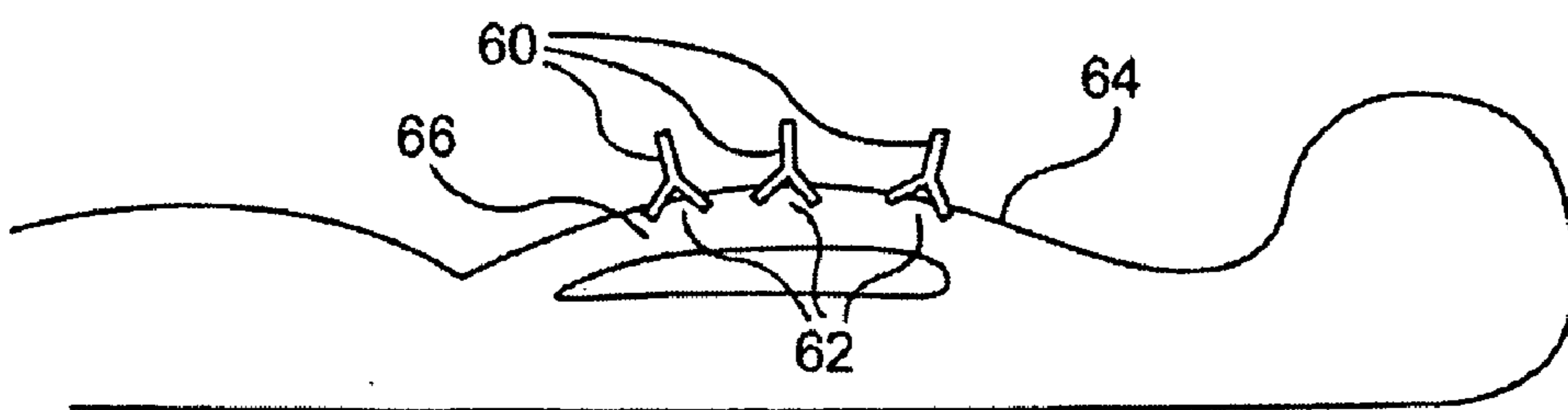
**Fig. 5C**



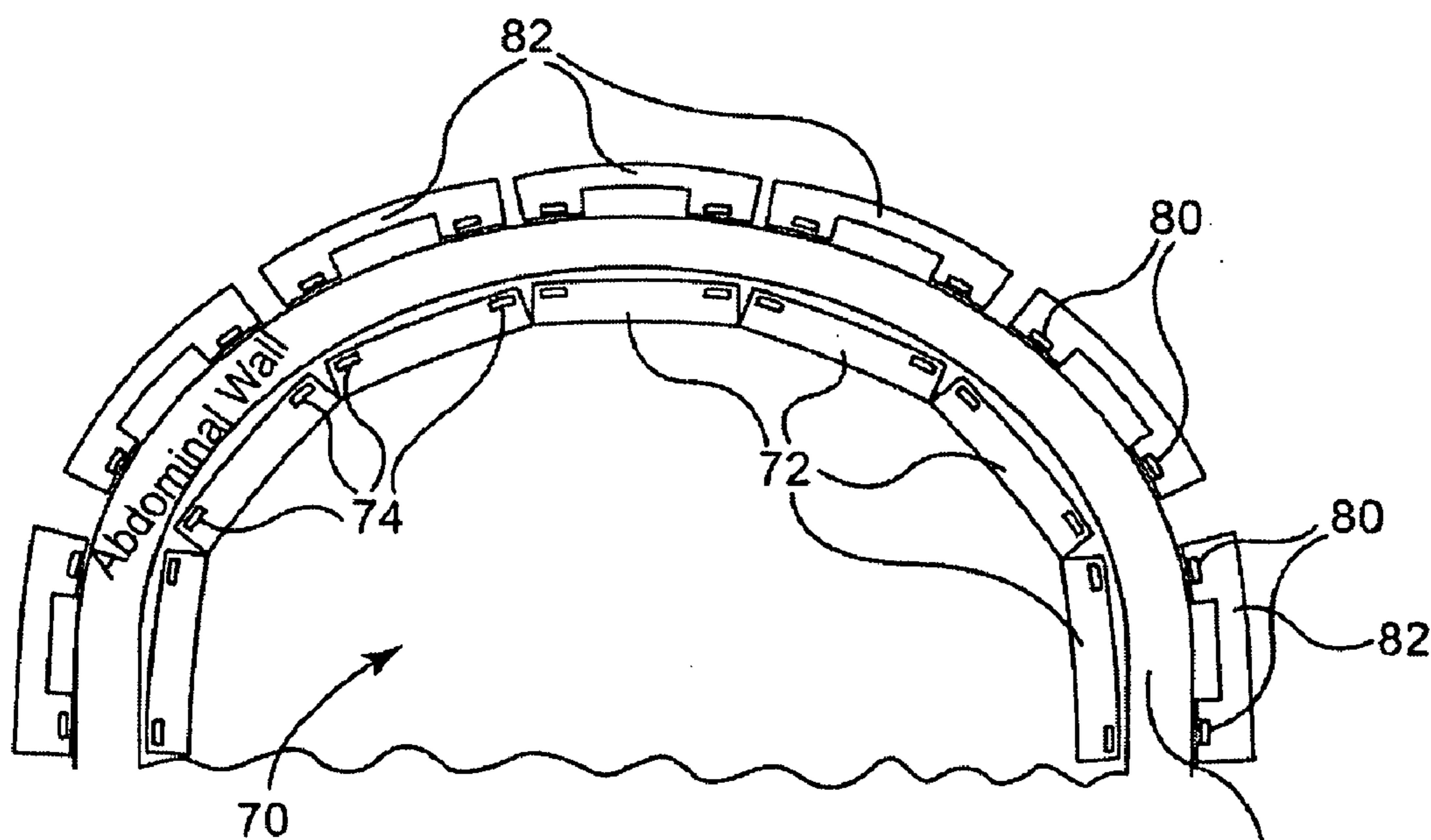
**Fig. 5D**



**Fig. 6A**

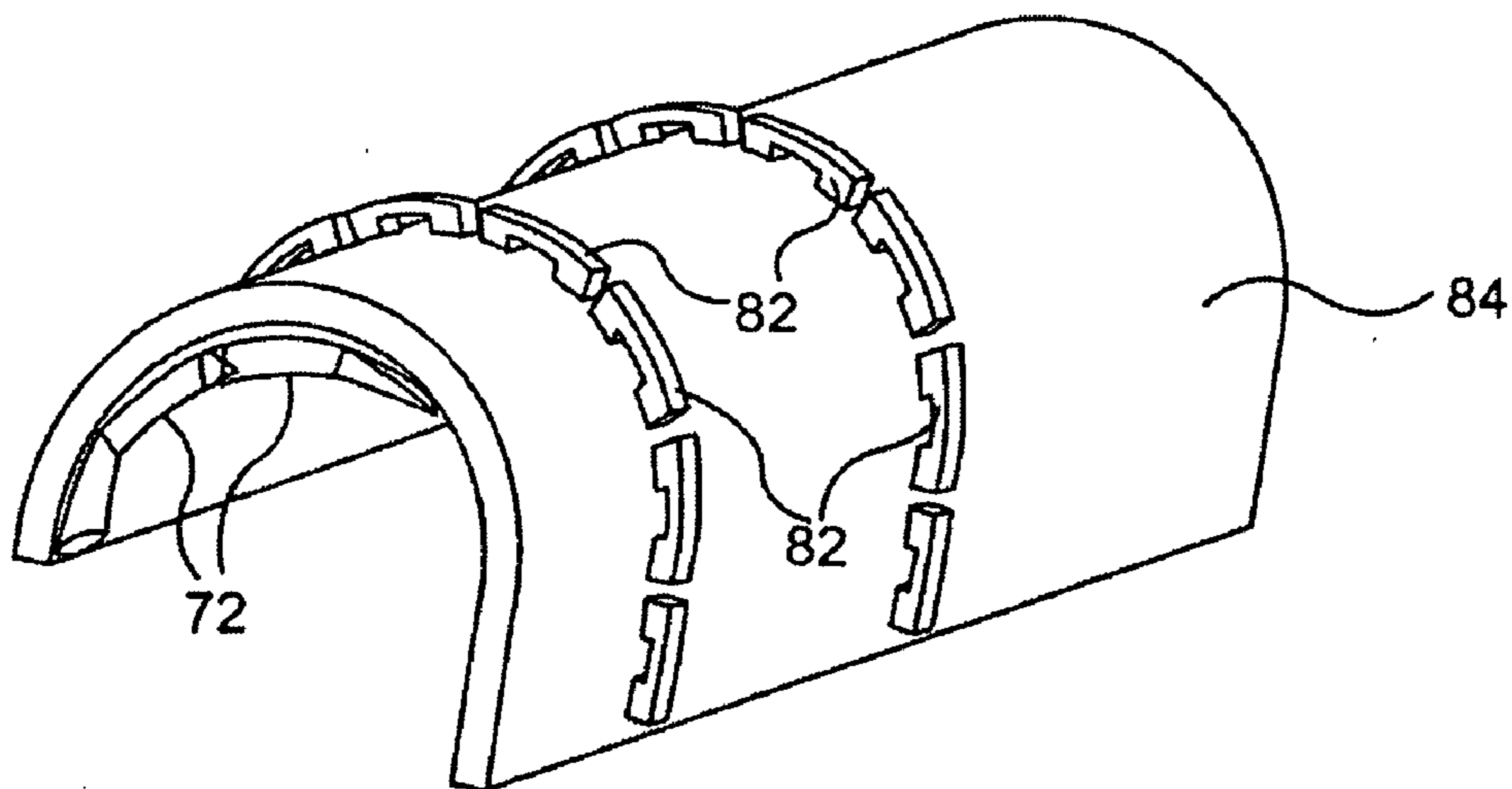


**Fig. 6B**

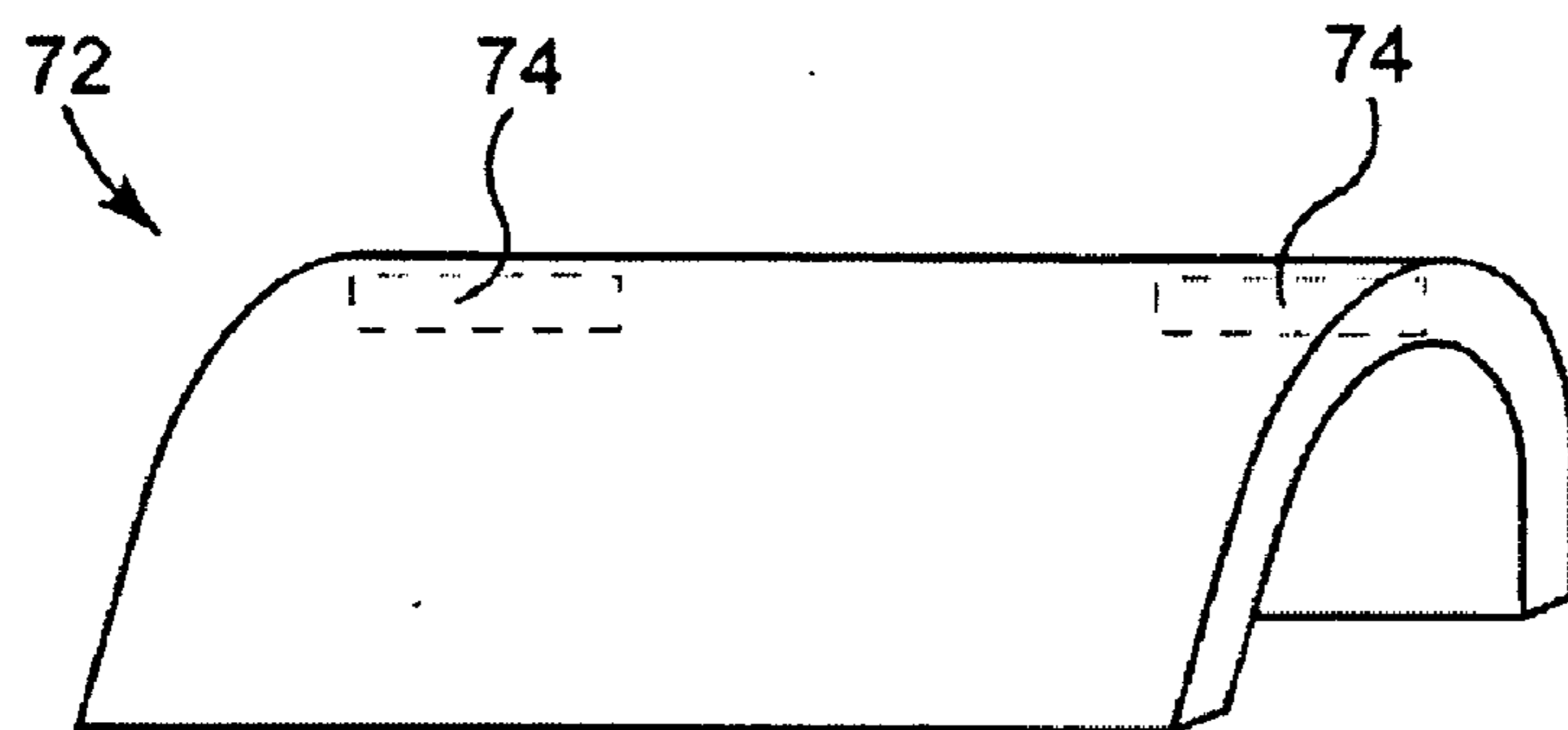


**Fig. 7A**

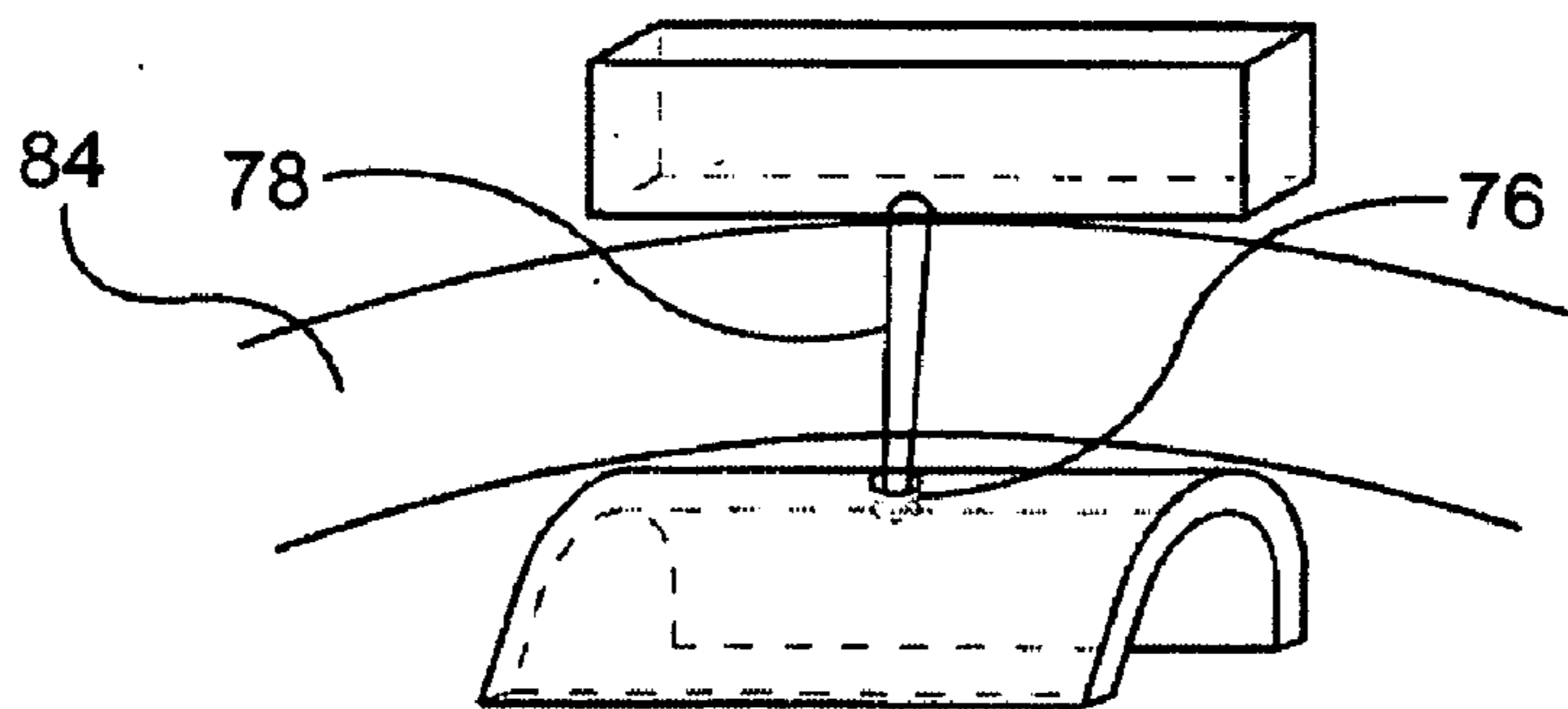




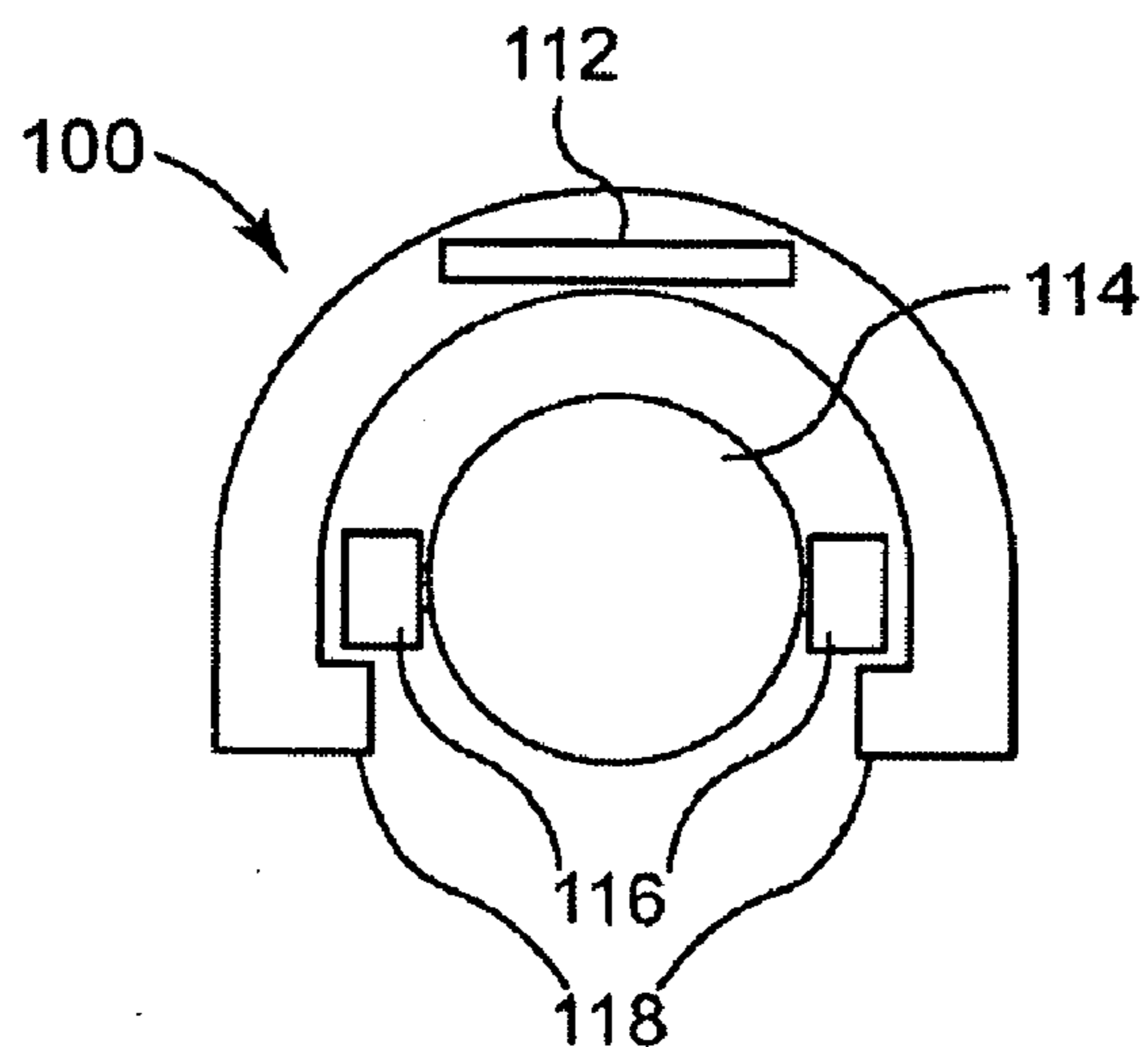
**Fig. 7B**



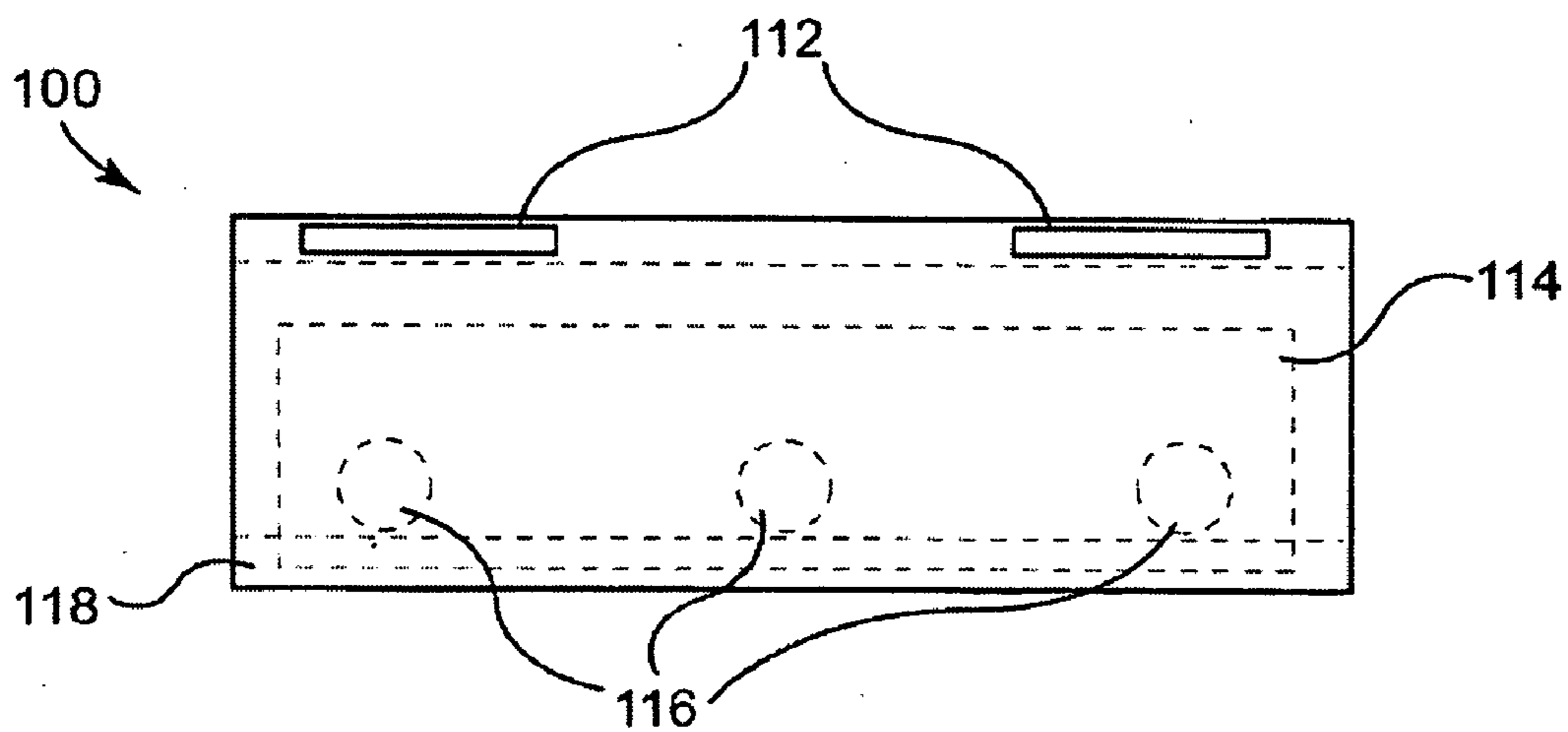
**Fig. 7C**



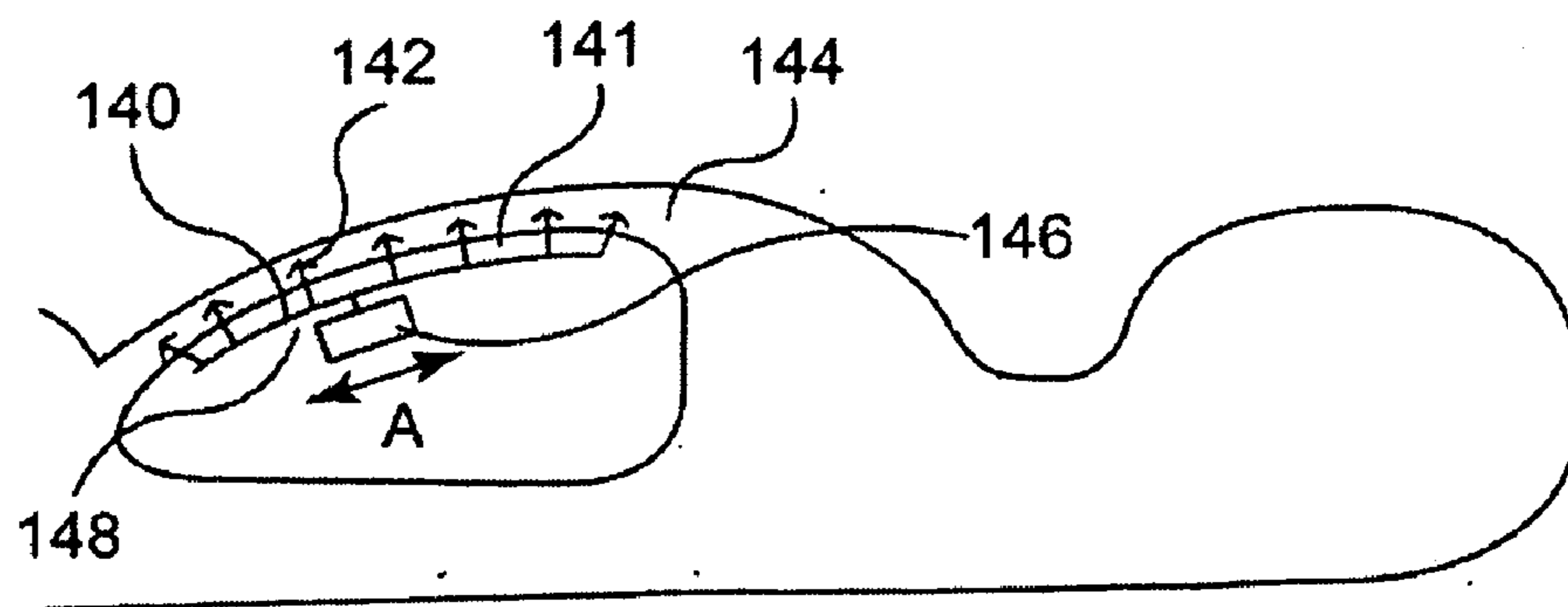
**Fig. 7D**



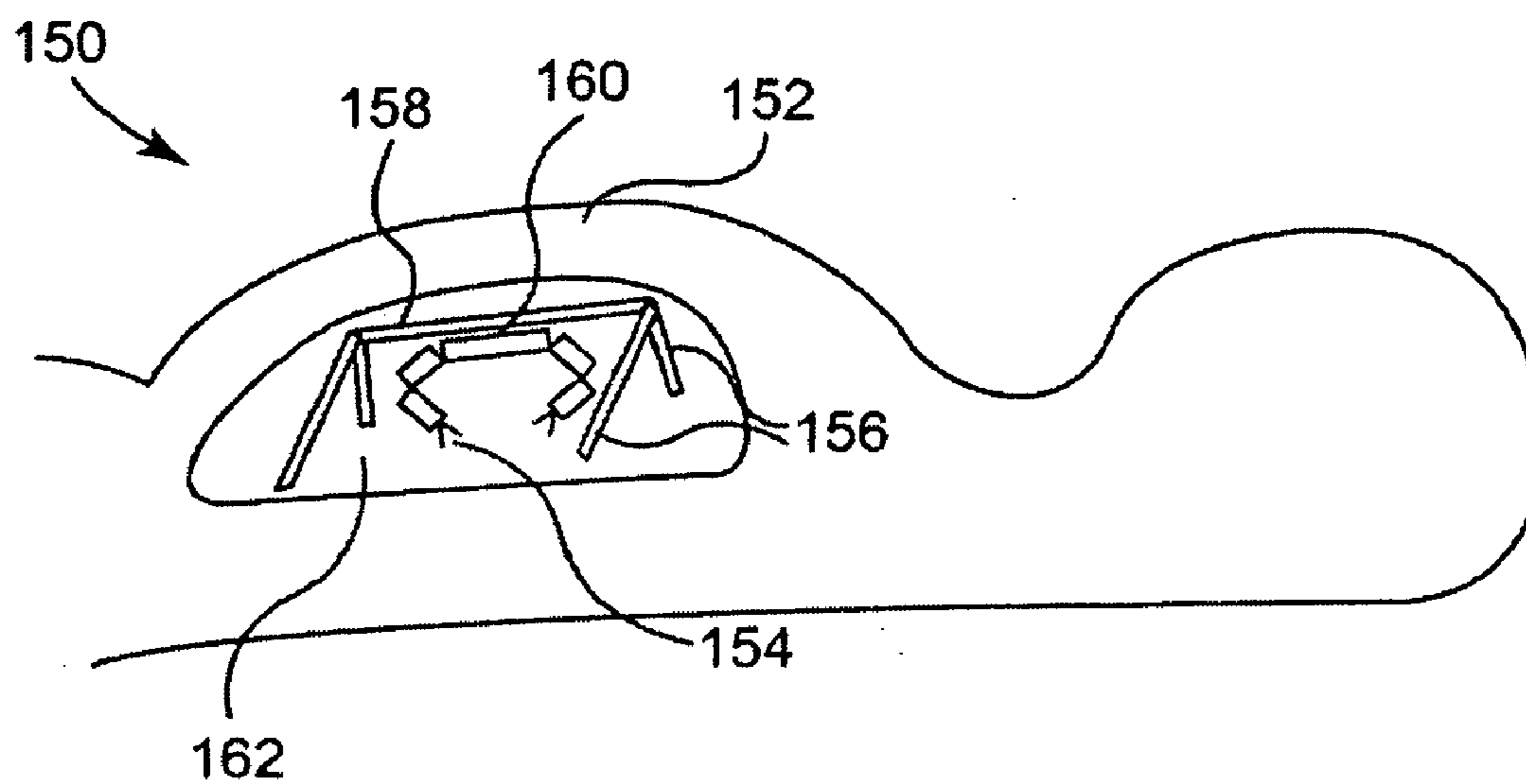
**Fig. 8A**



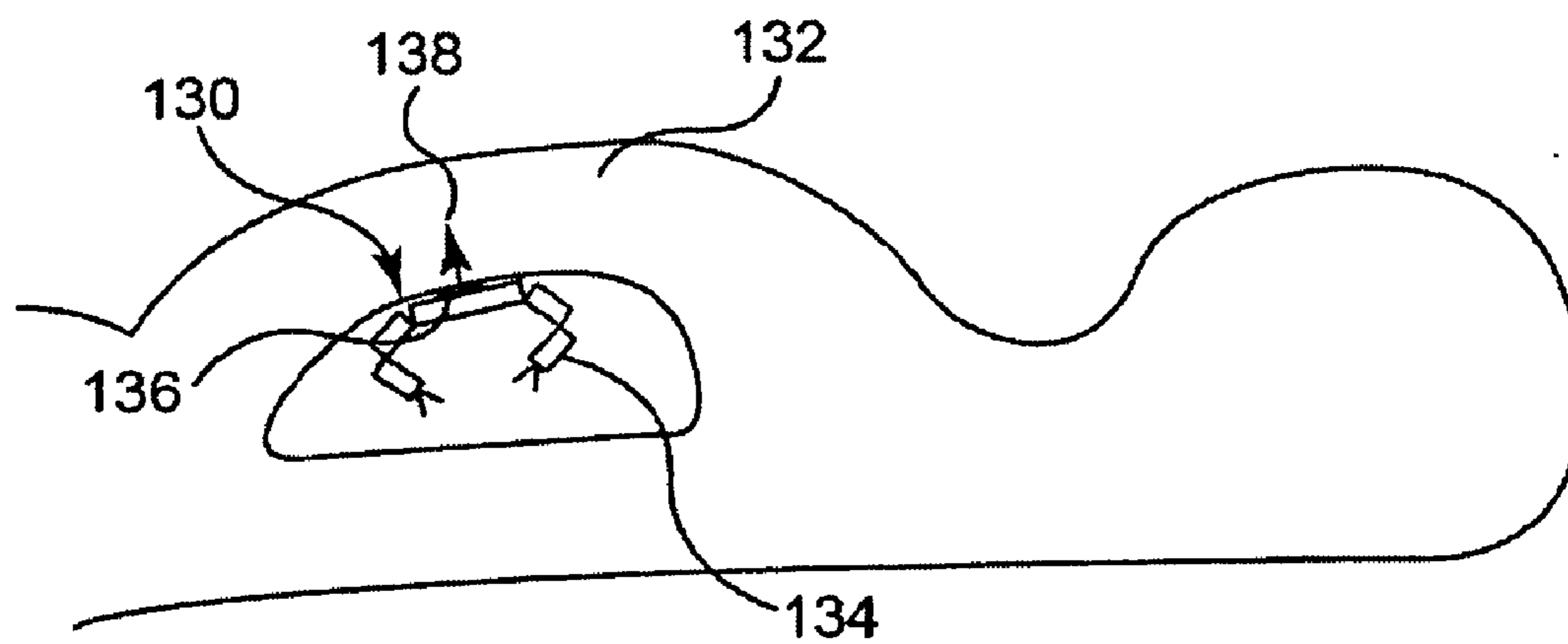
**Fig. 8B**



**Fig. 9**



**Fig. 10**



**Fig. 11**

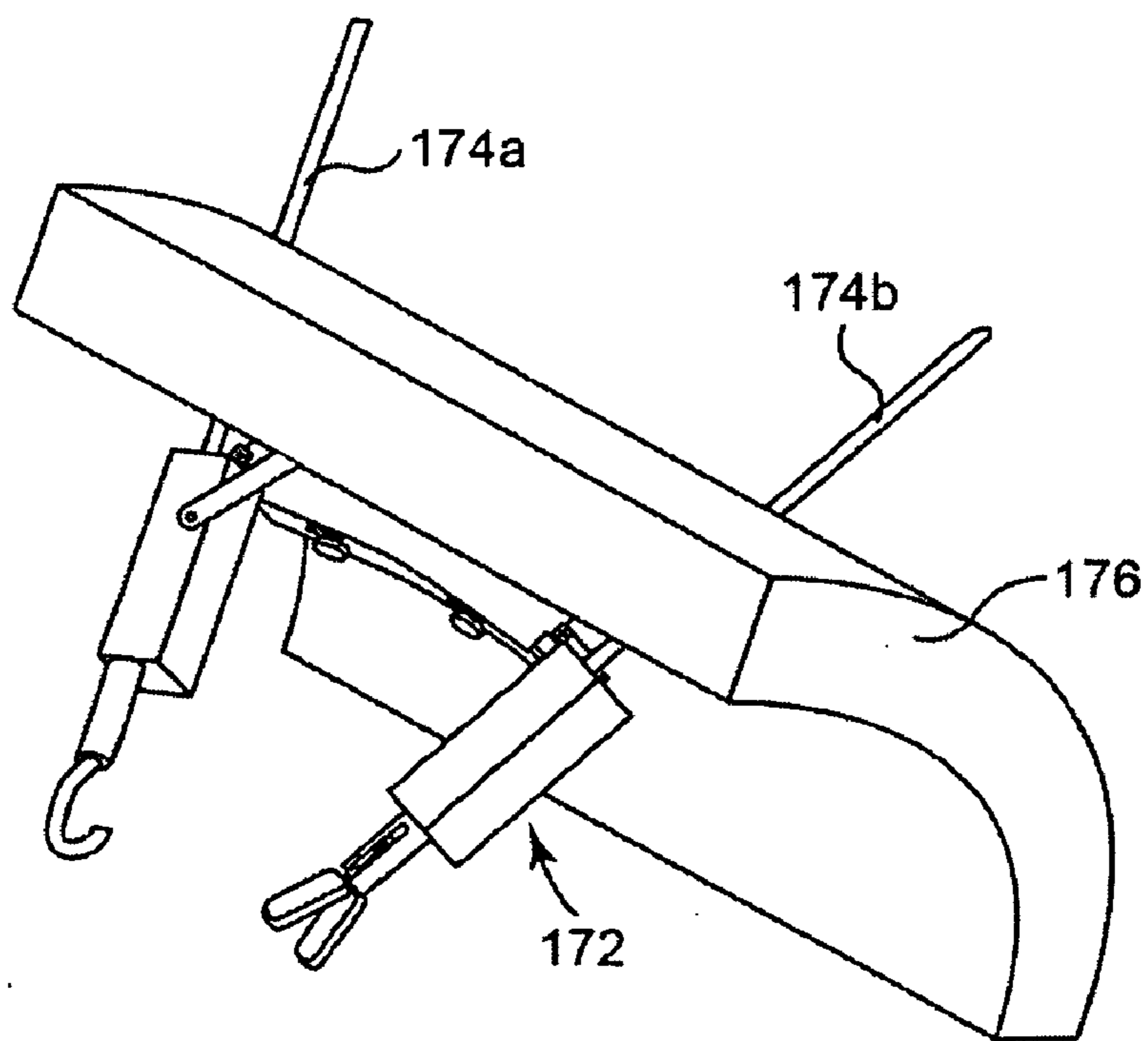


Fig. 12

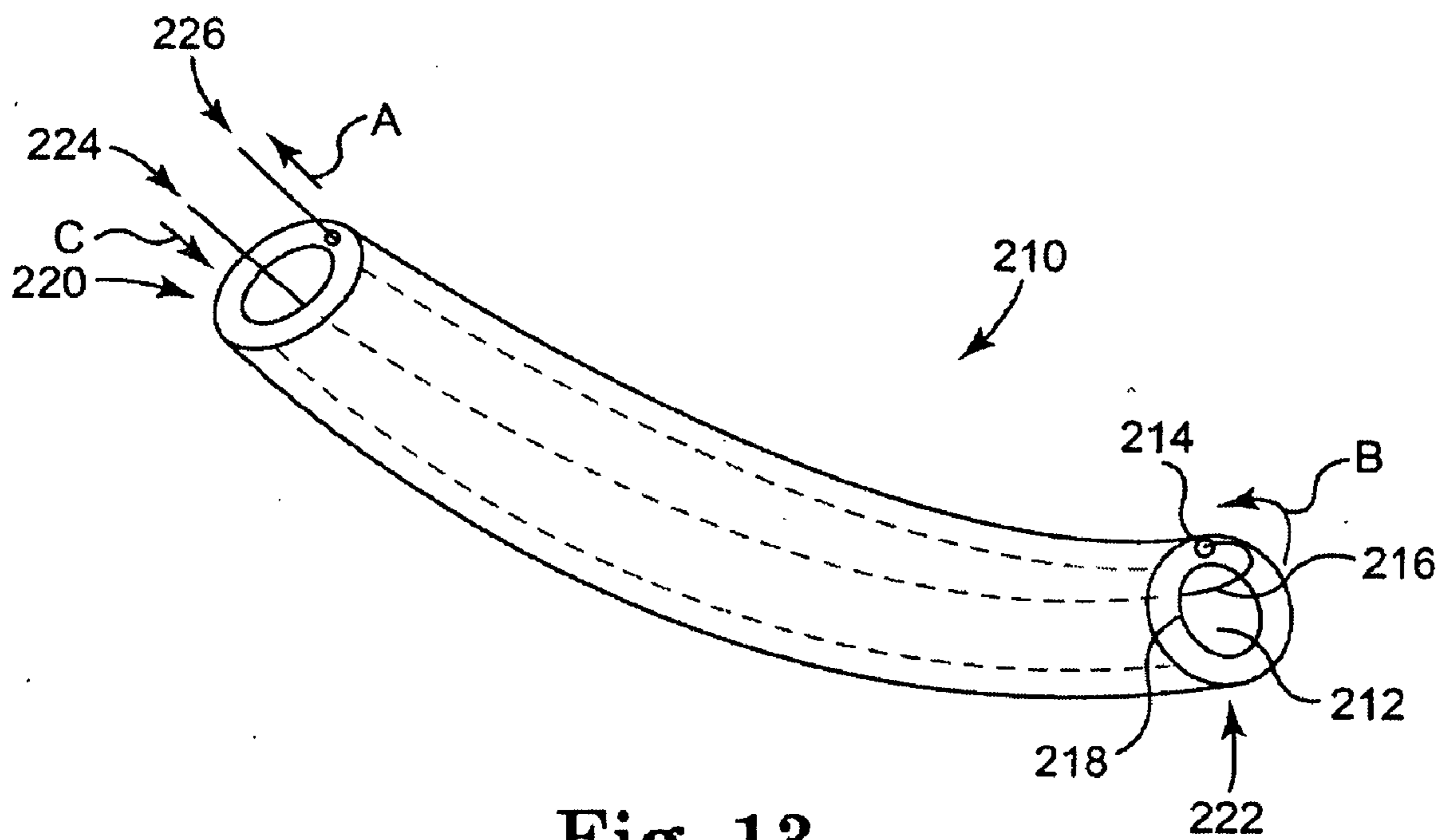


Fig. 13



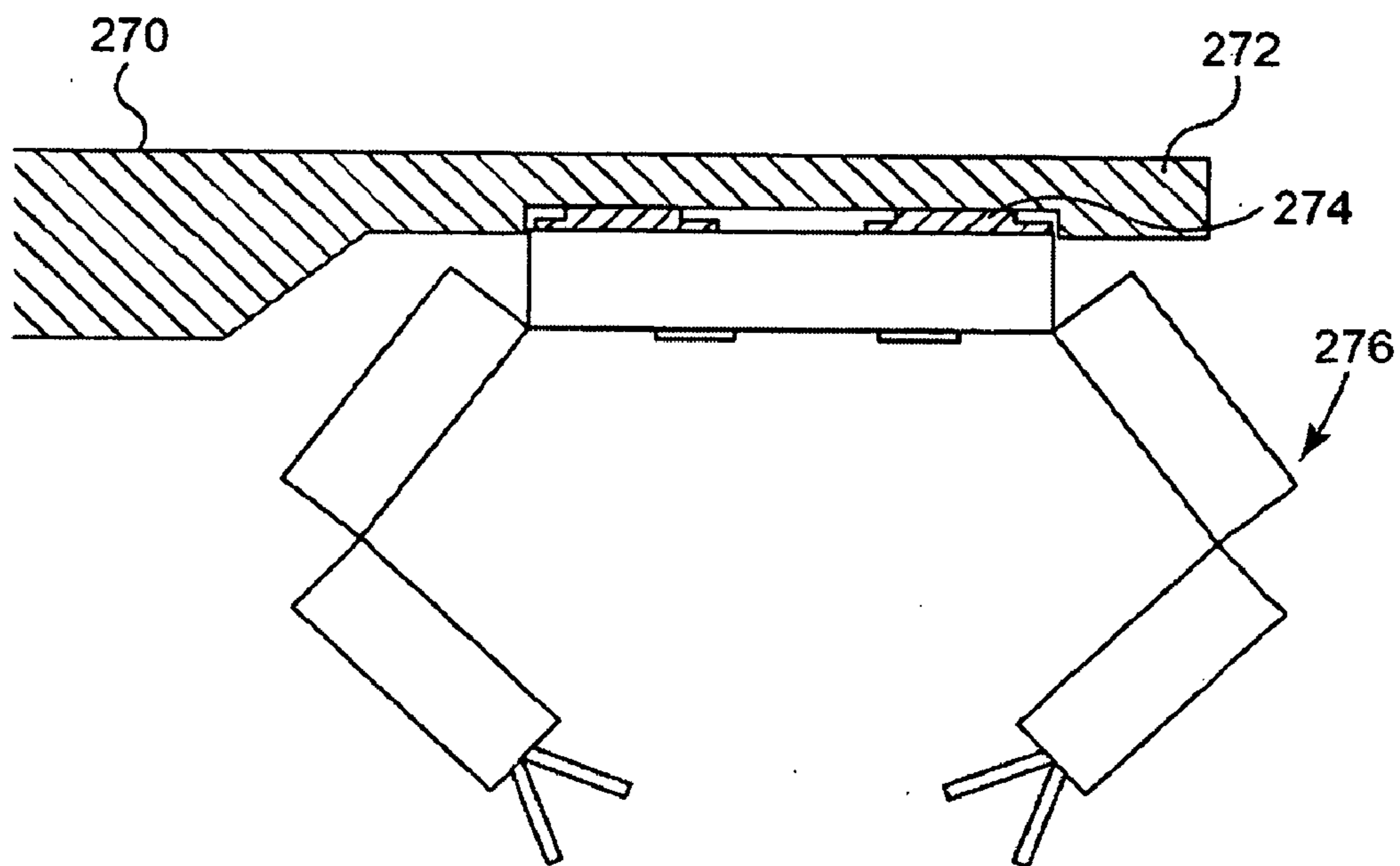


Fig. 16

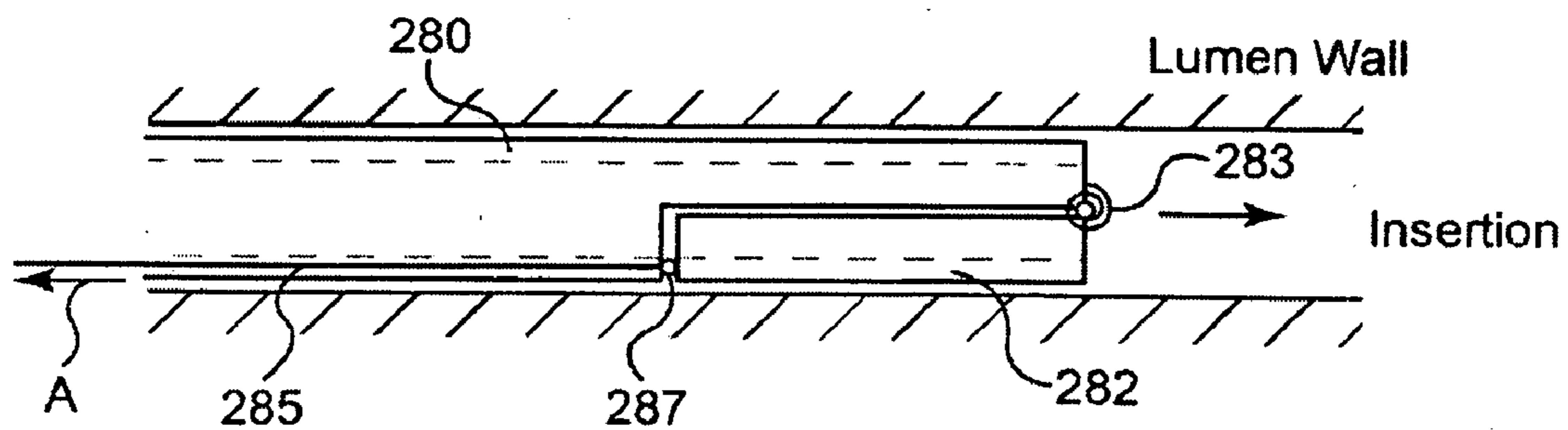
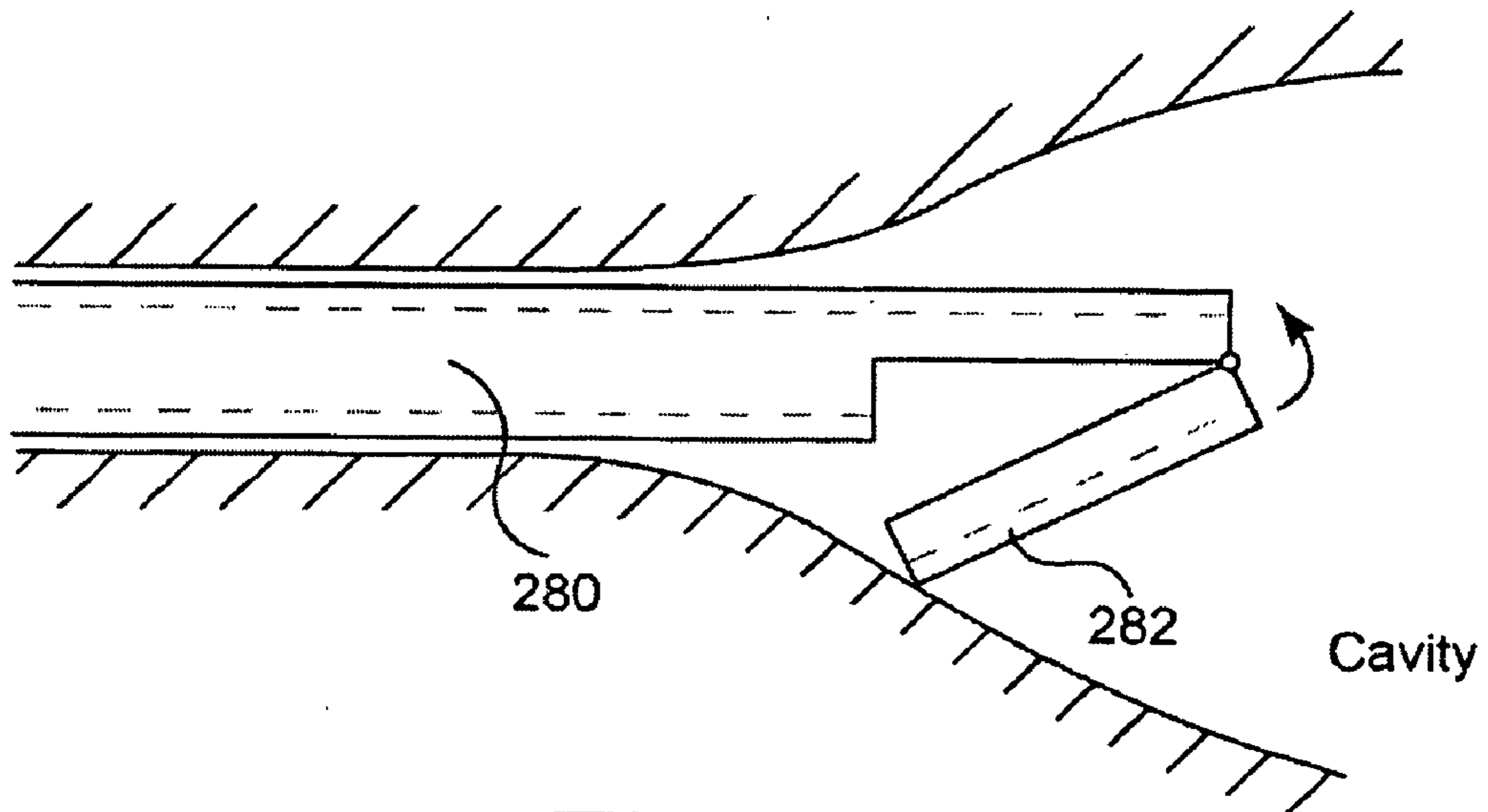
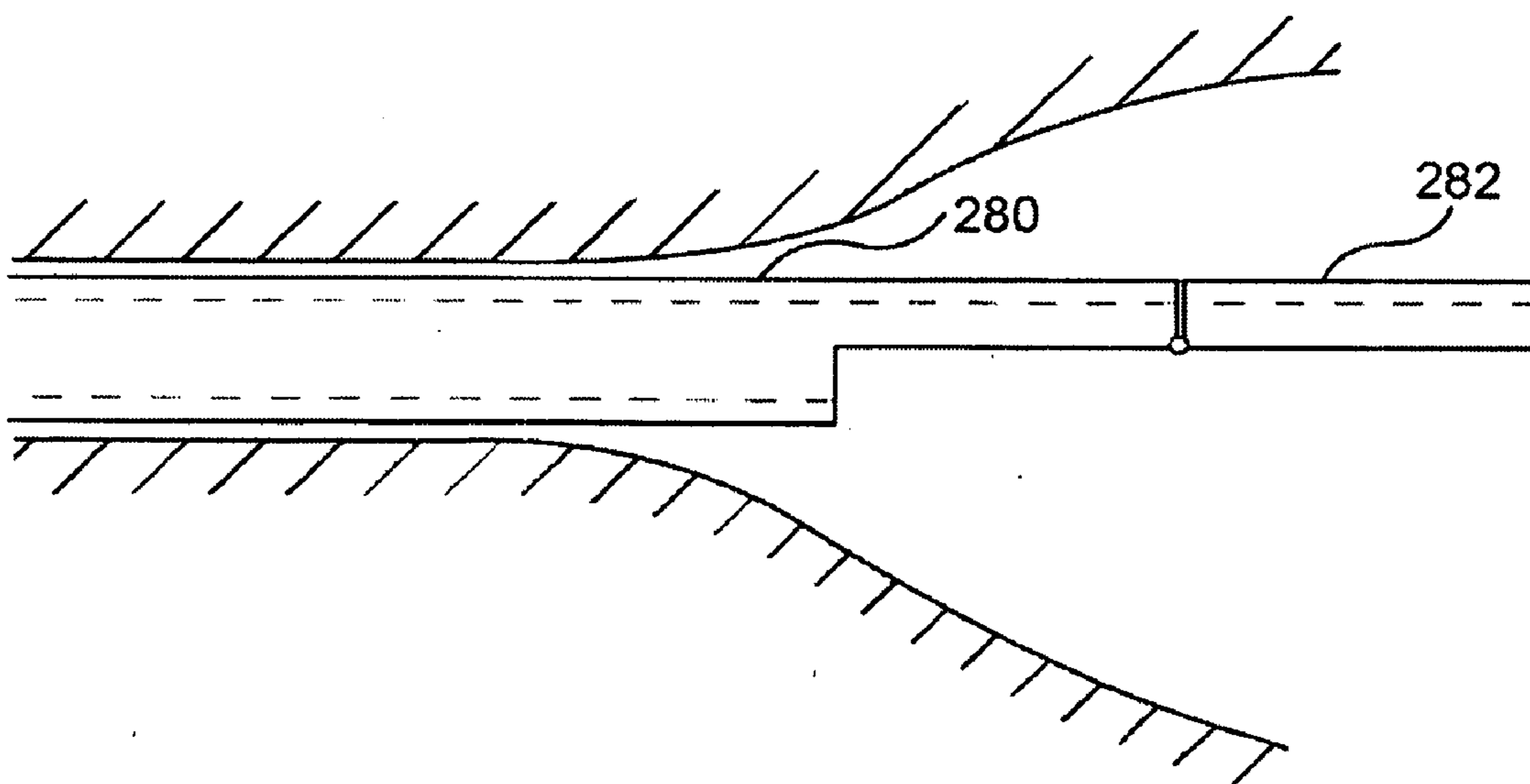


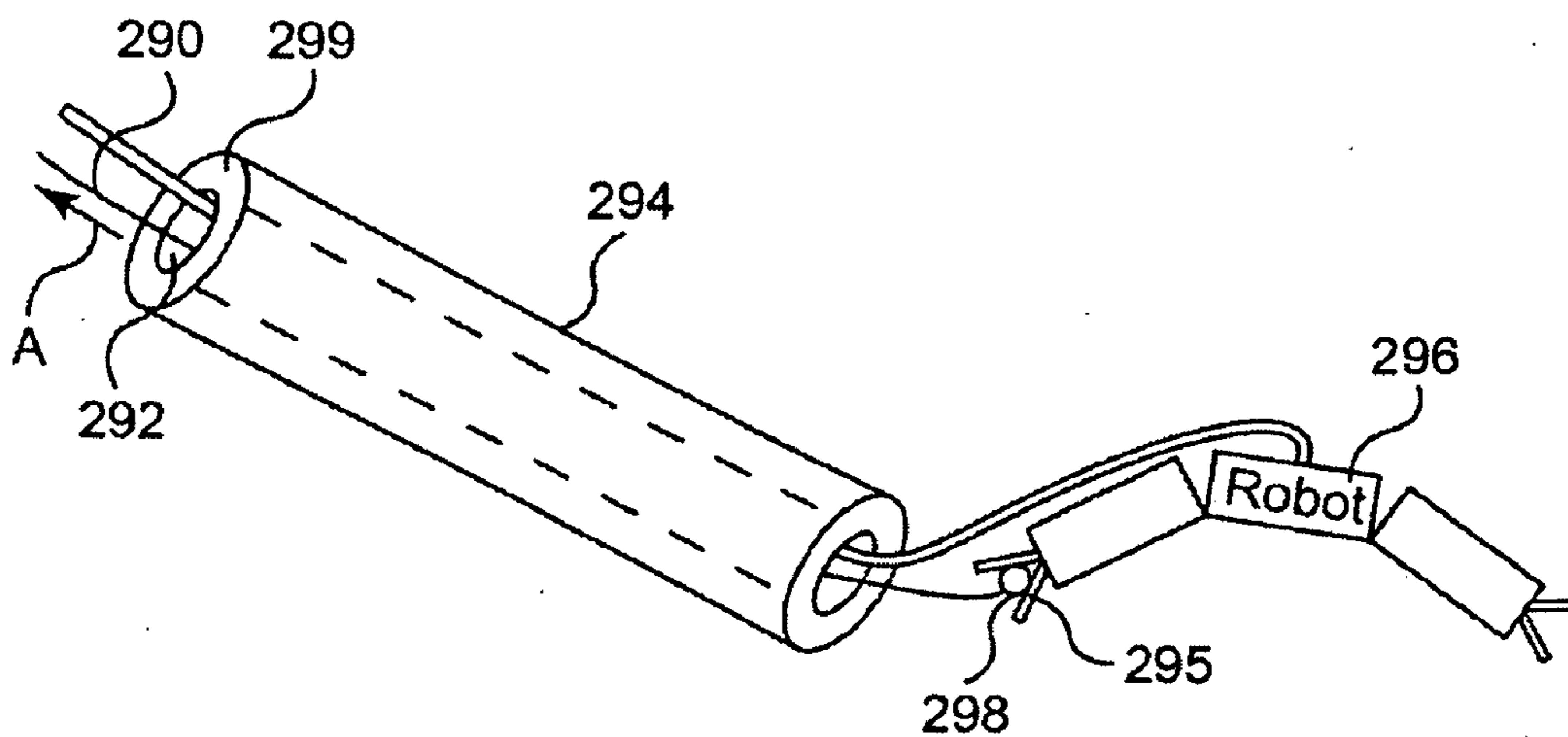
Fig. 17A



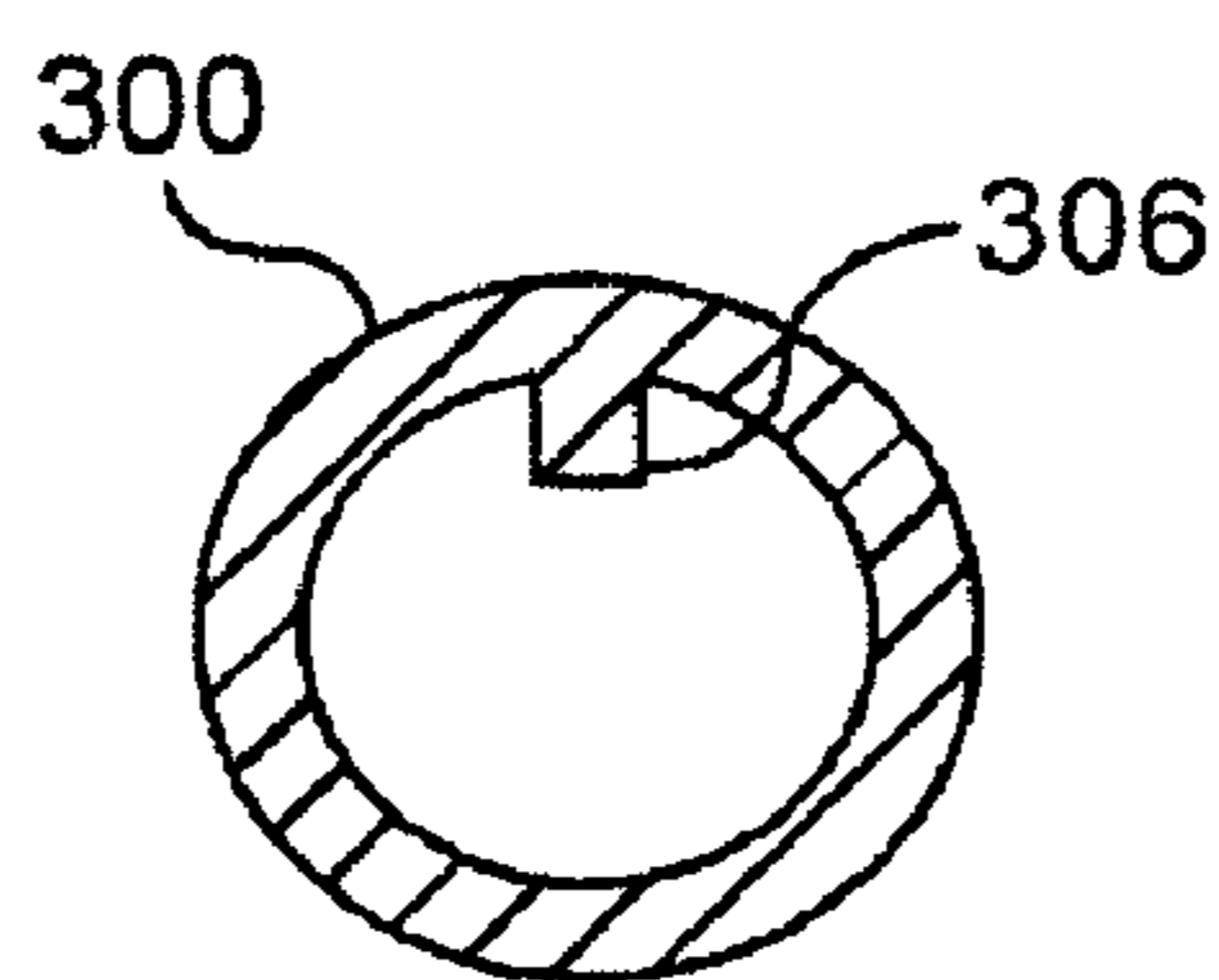
**Fig. 17B**



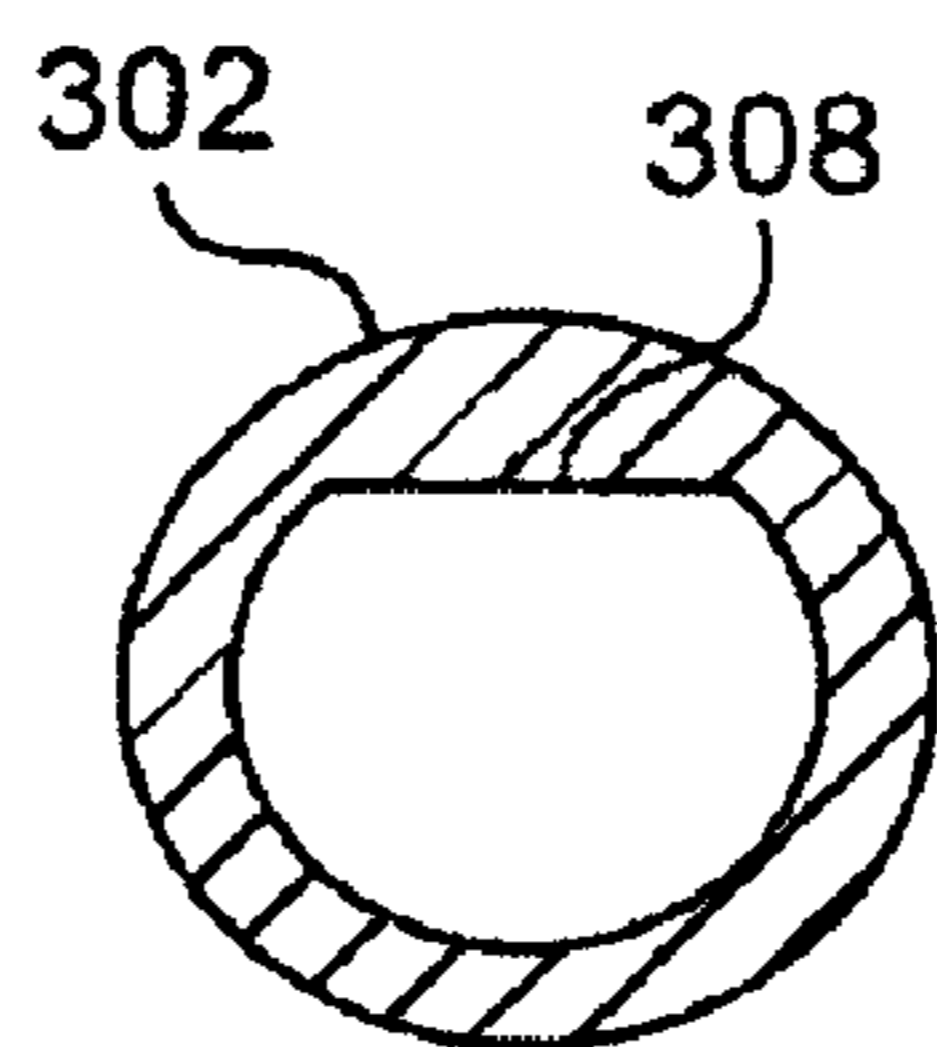
**Fig. 17C**



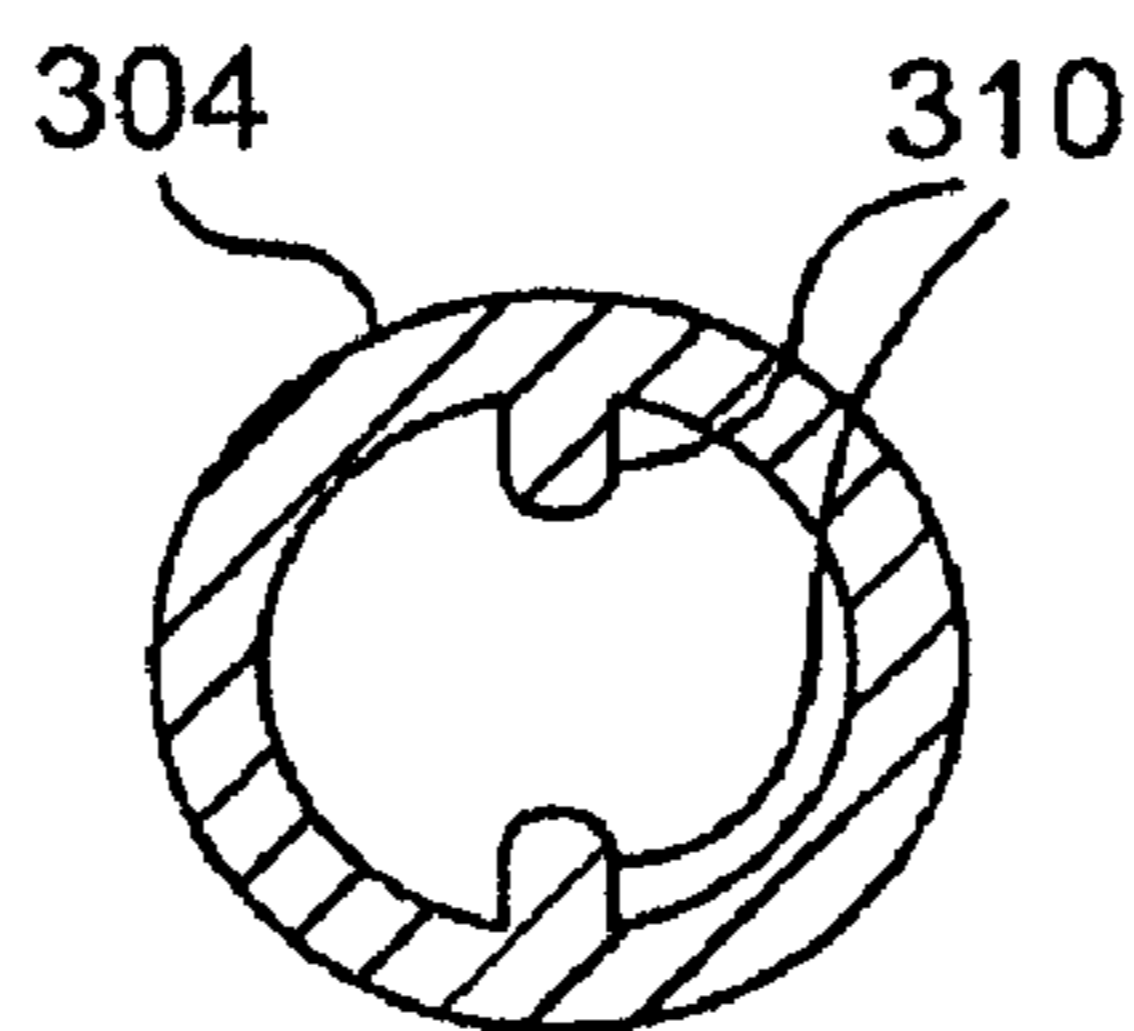
**Fig. 18**



**Fig. 19A**

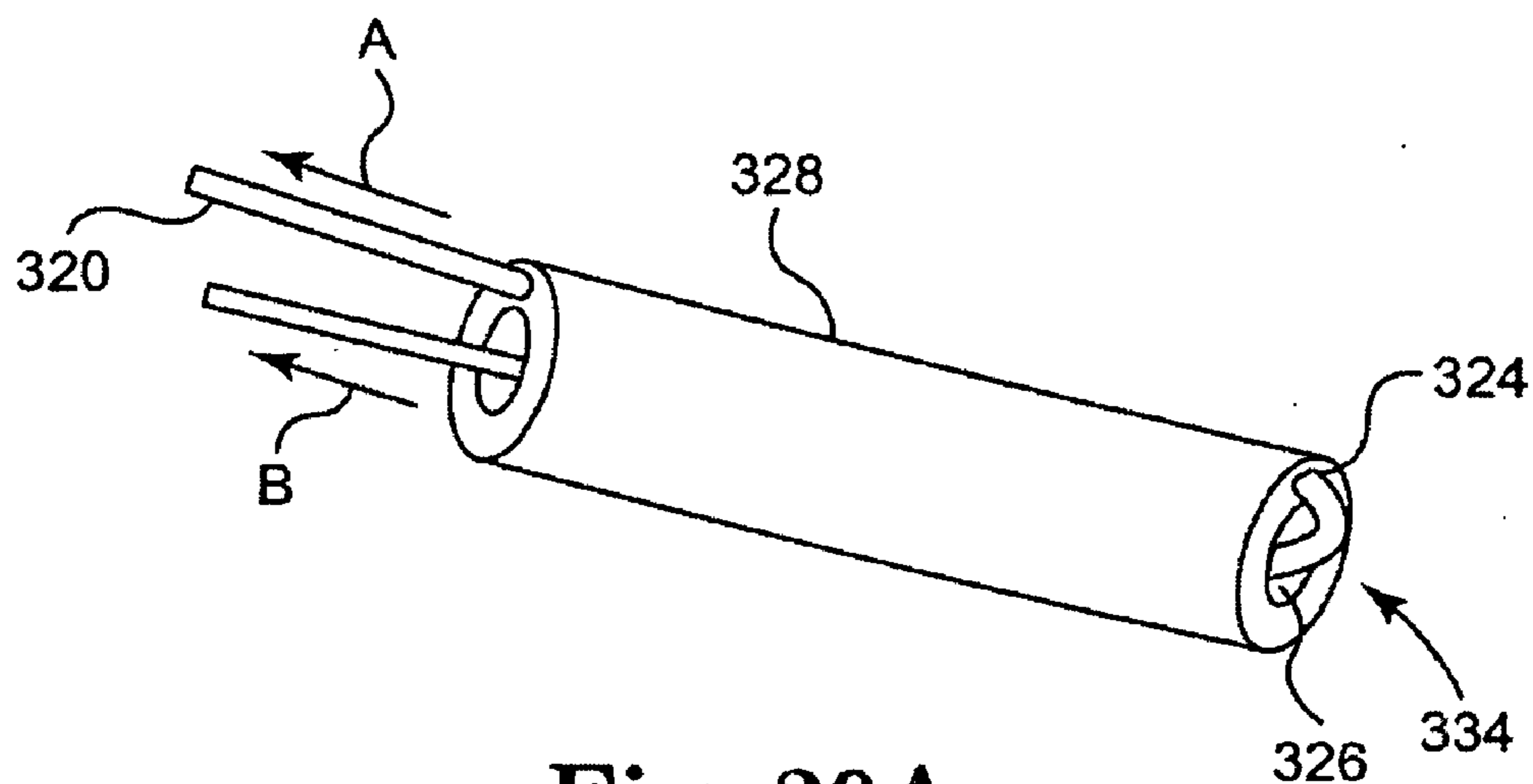


**Fig. 19B**

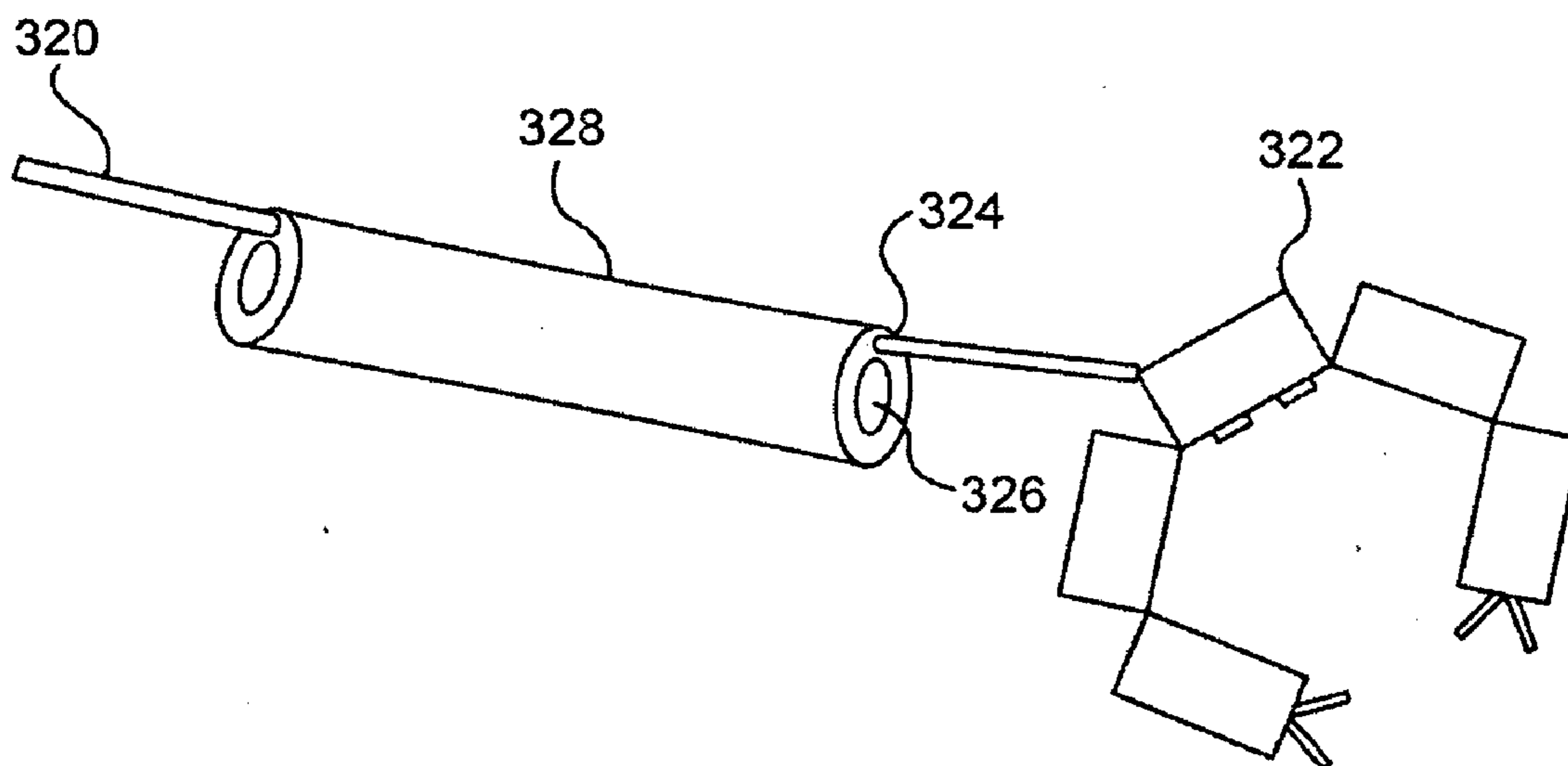


**Fig. 19C**





**Fig. 20A**



**Fig. 20B**

**MEDICAL INFLATION, ATTACHMENT, AND  
DELIVERY DEVICES AND RELATED  
METHODS**

CROSS-REFERENCE TO RELATED  
APPLICATIONS

[0001] This application claims priority to Provisional Application No. 60/956,032, filed Aug. 15, 2007; Provisional Application No. 60/990,062, filed Nov. 26, 2007; and Provisional Application No. 60/990,470, filed Nov. 27, 2007; all of which are hereby incorporated herein by reference in their entireties.

TECHNICAL FIELD

[0002] The embodiments disclosed herein relate to various medical devices and related components, including robotic and/or in vivo medical devices and related components, along with related procedures and methods. Certain embodiments include various cavity inflation or structural retention system embodiments, including inflatable devices, scaffold-like devices, and externally-supported wall retention devices. Further embodiments include various medical device attachment and control components, including attachment pin devices and magnetic attachment devices. Additional embodiments include various medical device delivery devices that can be used to deliver various types of medical devices, including in vivo devices, to target medical treatment areas, including tubular devices with operational distal ends that provide for simple delivery, control, and retrieval of various medical devices.

BACKGROUND

[0003] Invasive surgical procedures are essential for addressing various medical conditions. When possible, minimally invasive procedures such as laparoscopy are preferred.

[0004] However, known minimally invasive technologies such as laparoscopy are limited in scope and complexity due in part to 1) mobility restrictions resulting from using rigid tools inserted through access ports, and 2) limited visual feedback. Known robotic systems such as the da Vinci® Surgical System (available from Intuitive Surgical, Inc., located in Sunnyvale, Calif.) are also restricted by the access ports, as well as having the additional disadvantages of being very large, very expensive, unavailable in most hospitals, and having limited sensory and mobility capabilities.

[0005] There is a need in the art for improved surgical methods, systems, and devices.

SUMMARY

[0006] One embodiment disclosed herein relates to a body cavity spatial support device having an inflatable body and an inflation mechanism. In one embodiment, the body has a generally cylindrical shape, while in another embodiment it has a generally donut shape. Alternatively, the device can have two or more inflatable bodies.

[0007] Another embodiment disclosed herein relates to a collapsible body cavity spatial support device. The device has at least three links hingedly coupled to each other and is configured to have a collapsed configuration and a deployed configuration.

[0008] A further embodiment disclosed herein relates to a pin having a needle tip and a retention component. The pin can be configured to be inserted through a cavity wall and be

urged away from the cavity to maintain a procedural space in the cavity. According to one implementation, two or more pins are used cooperatively to maintain the procedural space.

[0009] Yet another embodiment disclosed herein relates to a pin having a grasping component configured to attach to an outer portion of the cavity wall. In one embodiment, two or more of these pins can be used cooperatively to maintain the procedural space.

[0010] One further embodiment disclosed herein relates to a procedural space maintenance system having at least two modular components that are coupled to each other and configured to be positioned inside a cavity of a patient. In one embodiment, the components each have at least one magnet. The system further comprises at least one external magnet configured to urge the at least two modular components away from the cavity and thereby maintain a procedural space in the cavity. In an alternative embodiment, the at least two modular components each have a mating or coupling component configured to couple with a medical device.

[0011] Another embodiment disclosed herein relates to a device positioning system having at least two modular components that are coupled to each other and configured to be positioned inside a cavity of a patient and attached to an interior cavity wall. The components are configured to couple together to create an attachment component along which a medical device can be positioned. Alternatively, the modular components have at least two legs to allow the system to be positioned in the cavity (instead of the attachment components for attaching to the interior wall).

[0012] A further embodiment disclosed herein relates to a device positioning and control system having at least one pin that is inserted through the cavity wall and coupled to an arm of a medical device positioned inside the body cavity. The pin can be used to maintain the position of the device and, according to a further embodiment, assist with the operation of the arm.

[0013] Yet another embodiment disclosed herein relates to a delivery or removal device having a tubular body, a device lumen, a wire lumen, and a wire disposed through the device and wire lumens. In accordance with one embodiment, the wire has an attachment component. In another embodiment, the tubular body has a protrusion at a distal end of the body. In a further embodiment, the protrusion is a deployable protrusion. In yet another embodiment, the protrusion has a device receiving component.

[0014] While multiple embodiments are disclosed, still other embodiments of the present invention will become apparent to those skilled in the art from the following detailed description, which shows and describes illustrative embodiments of the invention. As will be realized, the invention is capable of modifications in various obvious aspects, all without departing from the spirit and scope of the present invention. Accordingly, the drawings and detailed description are to be regarded as illustrative in nature and not restrictive.

BRIEF DESCRIPTION OF THE DRAWINGS

[0015] FIG. 1A is a side cutaway view depicting an inflatable device for maintaining procedural space in a body cavity, according to one embodiment.

[0016] FIG. 1B is a perspective cutaway view of the device of FIG. 1A.

[0017] FIG. 1C depicts another side cutaway view of the device of FIG. 1A.

[0018] FIG. 1D shows a perspective cutaway view of the uninflated device of FIG. 1A.

[0019] FIG. 2A is a perspective cutaway view of an inflatable device for maintaining procedural space in a body cavity, according to another embodiment.

[0020] FIG. 2B is a side cutaway view of the device of FIG. 2A.

[0021] FIG. 2C is a side cutaway view of the uninflated device of FIG. 2A.

[0022] FIG. 3 is a schematic depiction of an inflatable balloon having an inner skeleton, according to one embodiment.

[0023] FIG. 4A is a side cutaway view depicting a device for maintaining procedural space in a body cavity, according to one embodiment.

[0024] FIG. 4B is a perspective cutaway view of the device of FIG. 4A.

[0025] FIG. 4C is another side cutaway view of the device of FIG. 4A.

[0026] FIG. 4D is a schematic depiction of the device of FIG. 4A in a collapsed configuration.

[0027] FIG. 5A is a side view of a wall retention pin having a retention component in the collapsed configuration, according to one embodiment.

[0028] FIG. 5B is a side view the wall retention pin of FIG. 5A in which the retention component is in the deployed configuration.

[0029] FIG. 5C is a side cutaway view of three wall retention pins similar to that of FIG. 5A in use, according to one embodiment.

[0030] FIG. 5D is another side cutaway view of the three wall retention pins of FIG. 5C in a relaxed configuration in which the cavity wall is not being urged away from the cavity.

[0031] FIG. 6A is a side cutaway view of three wall retention pins, each having an attachment component, according to another embodiment.

[0032] FIG. 6B is another side cutaway view of the three wall retention pins of FIG. 6A in a relaxed configuration in which the cavity wall is not being urged away from the cavity.

[0033] FIG. 7A is a side cutaway view of a wall retention system, according to one embodiment.

[0034] FIG. 7B is a perspective cutaway view of the wall retention system of FIG. 7A.

[0035] FIG. 7C is a perspective view of one modular component of a wall retention system, according to one embodiment.

[0036] FIG. 7D is a perspective cutaway view of another modular component of a wall retention system, according to another embodiment.

[0037] FIG. 8A is an end view of a modular component of a wall retention system, according to a further embodiment.

[0038] FIG. 8B is a side view of the modular component of FIG. 8A.

[0039] FIG. 9 is a side cutaway view of a device support system, according to one embodiment.

[0040] FIG. 10 is a side cutaway view of another device support system, according to another embodiment.

[0041] FIG. 11 is a side cutaway view of yet another device support system, according to a further embodiment.

[0042] FIG. 12 is a perspective cutaway view of a device support and control system, according to another embodiment.

[0043] FIG. 13 is a perspective view of a procedural delivery device, according to one embodiment.

[0044] FIG. 14 is a perspective view of another delivery device, according to another embodiment.

[0045] FIG. 15 is a side cutaway view of another delivery device, according to a further embodiment.

[0046] FIG. 16 is a side view of another delivery device component, according to another embodiment.

[0047] FIG. 17A is a side cutaway view of another delivery device, according to another embodiment.

[0048] FIG. 17B is another side cutaway view of the delivery device of FIG. 17A.

[0049] FIG. 17C is another side cutaway view of the delivery device of FIG. 17A.

[0050] FIG. 18 is a perspective view of a retraction device, according to one embodiment.

[0051] FIG. 19A is a cross-sectional depiction of an insertion device, according to one embodiment.

[0052] FIG. 19B is a cross-sectional depiction of another insertion device, according to one embodiment.

[0053] FIG. 19A is a cross-sectional depiction of a further insertion device, according to one embodiment.

[0054] FIG. 20A is a perspective view of an insertion and retraction device, according to one embodiment.

[0055] FIG. 20B is another perspective view of the device of FIG. 20A.

#### DETAILED DESCRIPTION

[0056] The various systems and devices disclosed herein relate to devices for use in medical procedures and systems. More specifically, the various embodiments relate to various cavity inflation or structural retention system embodiments, various medical device attachment and control components, and various medical device delivery, control, and retrieval devices, all of which can be used in various procedural devices and systems.

[0057] It is understood that the various embodiments of cavity structural retention systems, device attachment components, and device delivery, control, and retrieval systems and other types of devices disclosed herein can be incorporated into or used with any known medical devices, including, but not limited to, robotic or in vivo devices as defined herein.

[0058] For example, the various embodiments disclosed herein can be incorporated into or used with any of the medical devices disclosed in copending U.S. applications Ser. No. 11/932,441 (filed on Oct. 31, 2007 and entitled "Robot for Surgical Applications"), Ser. No. 11/695,944 (filed on Apr. 3, 2007 and entitled "Robot for Surgical Applications"), Ser. No. 11/947,097 (filed on Nov. 27, 2007 and entitled "Robotic Devices with Agent Delivery Components and Related Methods"), Ser. No. 11/932,516 (filed on Oct. 31, 2007 and entitled "Robot for Surgical Applications"), Ser. No. 11/766,683 (filed on Jun. 21, 2007 and entitled "Magnetically Coupleable Robotic Devices and Related Methods"), Ser. No. 11/766,720 (filed on Jun. 21, 2007 and entitled "Magnetically Coupleable Surgical Robotic Devices and Related Methods"), Ser. No. 11/966,741 (filed on Dec. 28, 2007 and entitled "Methods, Systems, and Devices for Surgical Visualization and Device Manipulation"), Ser. No. 12/171,413 (filed on Jul. 11, 2008 and entitled "Methods and Systems of Actuation in Robotic Devices"), 60/956,032 (filed Aug. 15, 2007), 60/990,062 (filed on Nov. 26, 2007), 60/990,076 (filed Nov. 26, 2007), 60/990,086 (filed on Nov. 26, 2007), 60/990,106 (filed on Nov. 26, 2007), 60/990,470 (filed on Nov. 27, 2007), 61/030,

588 (filed on Feb. 22, 2008), and 61/030,617 (filed on Feb. 22, 2008), all of which are hereby incorporated herein by reference in their entireties.

**[0059]** In an exemplary embodiment, any of the various embodiments disclosed herein can be incorporated into or used with a natural orifice transluminal endoscopic surgical device, such as a NOTES device. Those skilled in the art will appreciate and understand that various combinations of features are available including the features disclosed herein together with features known in the art.

**[0060]** Certain device implementations disclosed in the applications listed above can be positioned within a body cavity of a patient, including certain devices that can be positioned against or substantially adjacent to an interior cavity wall, and related systems. An “in vivo device” as used herein means any device that can be positioned, operated, or controlled at least in part by a user while being positioned within a body cavity of a patient, including any device that is positioned substantially against or adjacent to a wall of a body cavity of a patient, further including any such device that is internally actuated (having no external source of motive force), and additionally including any device that may be used laparoscopically or endoscopically during a surgical procedure. As used herein, the terms “robot,” and “robotic device” shall refer to any device that can perform a task either automatically or in response to a command.

**[0061]** Certain implementations disclosed herein relate to cavity inflation or cavity structural retention devices or systems that are configured to provide space within the cavity of a patient for purposes of operating various medical devices and components within the cavity to perform one or more of various medical procedures, including, for example, the various medical devices and procedures disclosed in the various applications listed above and incorporated herein.

**[0062]** FIGS. 1A-1D, 2A-2C, and 3 depict various embodiments of inflatable devices that can be used to provide or create procedural space in a body cavity.

**[0063]** FIGS. 1A-1D depict one example of an inflatable cavity inflation system 10A, 10B, according to one embodiment. In this embodiment, the system 10A, 10B has two inflatable components 10A, 10B, which can also be referred to herein as “balloons.” The two balloons 10A, 10B can be inserted into and positioned in a body cavity as best shown in FIGS. 1A-1C such that they create or provide space within the cavity that allows a user (such as a doctor or surgeon) to operate various devices and/or perform various procedures within the space in the cavity. The two balloons 10A, 10B can be positioned in any fashion within the cavity to maintain the surgical space in the cavity. Alternatively, one inflation balloon or more than two inflation balloons can be positioned in the body cavity.

**[0064]** According to one embodiment, the body cavity is the abdominal cavity 12 as shown best in FIGS. 1A-1C. In such an embodiment, the balloons 10A, 10B are positioned on or adjacent to the various organs and tissues 14 in the cavity 12. Alternatively, the cavity can be any known body cavity.

**[0065]** In one implementation, the inflatable components 10A, 10B are made of polyethylene terephthalate (“PET”), which is manufactured by Advanced Polymers, Inc. of Salem, HN. Alternatively, the components 10A, 10B can be made of nylon. In a further alternative, the components 10A, 10B are made of polyurethane. In yet another alternative, the compo-

nents 10A, 10B can be made of any known expandable, durable, biocompatible material that can be used in medical devices.

**[0066]** The inflatable components 10A, 10B in one embodiment have tubing (not shown) or any other such connection attached to the components 10A, 10B that can couple the components to an external pump (not shown) that can be used to inflate the balloons 10A, 10B. Alternatively, the inflatable components 10A, 10B each have an inflation device (not shown) disposed somewhere within or on each balloon 10A, 10B that can be used to inflate each balloon 10A, 10B. According to one embodiment, the inflation device is a robotic device with a pressurized cavity that is opened for “self” inflation of the balloon.

**[0067]** In an alternative embodiment as shown in FIGS. 2A-2C, a single inflatable component 20 is provided that is shaped like a donut or hoop. In this embodiment, the single component 20 can provide sufficient space within the patient’s cavity to allow a user to operate a medical device and/or perform a medical procedure. According to one implementation, the donut-shaped balloon 20 can be positioned over the target procedural site such that the open portion in the center of the balloon 22 forms or maintains a procedural cavity space for purposes of the procedure.

**[0068]** It is understood that such a donut-shaped balloon 20 can be made of the same material as the balloons 10A, 10B discussed above.

**[0069]** In use, any of the balloons 10A, 10B, 20 can be utilized in the following manner. The un-inflated balloon(s) can be positioned inside the cavity as shown for example in FIGS. 1D and 2C. Once positioned, the balloon (or balloons) is inflated to provide or create procedural space within the cavity. At the conclusion of the procedure, the balloon(s) can be deflated or the pressurized gas can be sucked out by an external pump, and then the balloon(s) can be removed.

**[0070]** In a further alternative, any configuration of the balloons 10A, 10B, 20 can include internal structural members such as a series of pins or linkages inside of the balloons. FIG. 3 provides a schematic depiction of one embodiment of a balloon 30 having a skeleton or inner structure 32 disposed within the balloon 30. In the embodiment of FIG. 3, the skeleton 32 is a wire mesh similar to a stent. Alternatively, the skeleton 32 can be any structure configured to provide some deployable rigidity or structure to the balloon 30.

**[0071]** In use, the balloon 30 can be inserted in a deflated or undeployed state and, once positioned as desired, the inner structure 32 is triggered to expand into the deployed position as shown in FIG. 3 to provide or maintain a procedural space within a body cavity. According to one implementation, the inner skeleton 32 deploys in a fashion similar to a vascular stent, in which a tool of some kind is used to actuate the skeleton 32 to deploy. According to a further embodiment, the skeleton 32 locks into place upon deployment.

**[0072]** It is understood that many different medical devices, components, and procedures can be used in conjunction with the various inflatable device embodiments as shown in FIGS. 1A-1D, 2A-2C, and 3, including the positionable in vivo devices and various robotic devices and procedures described in the various applications disclosed and incorporated by reference above. That is, the various inflatable device embodiments can be used to provide and/or maintain procedural space in a body cavity such that any type procedure or related device for use in a body cavity can be used in the

space, including the various devices and procedures disclosed and incorporated by reference above.

[0073] FIGS. 4A-4D depict a different support device 40 for providing or creating procedural space in a body cavity, according to one embodiment. This device 40 can be a scaffold-like structure intended to be expandable or deployable within the body cavity.

[0074] As shown best in FIGS. 4A-4C, the support device 40 operates to hold the upper cavity wall up in a tent-like fashion. That is, the device 40 can be positioned within a body cavity such as an abdominal cavity 42 to provide a procedural space 44. The device 40 has a plurality of arms 46 (also referred to as “linkages”) as shown in FIGS. 4A and 4B. In one embodiment, the arms 46 are all mechanically coupled to each other such that they can be converted between a collapsed configuration as depicted in FIG. 4D and the deployed configuration as shown in FIGS. 4A-4C. The device 40 is deployed by actuating the arms 46 into the configuration as shown. In one embodiment, the device 40 is deployed automatically through the use of springs or inflatable balloons that are attached at or otherwise positioned in the hinges 48 of the device 40. Alternatively, the device 40 has motors or hydraulics that can be used to mechanically deploy the device 40. In a further alternative, any known component that can urge the device 40 from the collapsed configuration to the deployed configuration can be coupled or otherwise associated with the hinges of the device 40.

[0075] The arms 46 of the device 40 can be made of any biocompatible polymers. Alternatively, the arms 46 can be made of stainless steel. In a further alternative, the arms 46 can be made of any known substantially rigid, biocompatible material.

[0076] It is understood that the arms 46 of the device 40 are coupled at joints 48, as best shown in FIGS. 4B and 4D, or other similar known connection components. It is further understood that these joints 48 can be any known pivot or hinge joints. Alternatively, the joints 48 can be universal joints with rotation in two planes.

[0077] In accordance with another implementation, externally-supported wall retention systems and devices are provided to create and/or maintain a procedural space in a body cavity.

[0078] It is understood that many different medical devices, components, and procedures can be used in conjunction with the various support device embodiments as shown in FIGS. 4A-4D, including the positionable in vivo devices and various robotic devices and procedures described in the various applications incorporated by reference above. That is, the various support device embodiments can be used to provide and/or maintain procedural space in a body cavity such that any type procedure or related device for use in a body cavity can be used in the space, including the various devices and procedures disclosed and incorporated by reference above.

[0079] FIGS. 5A-5D depict one embodiment of an externally-supported wall retention system. In this embodiment, the system relates to at least two retention pins similar to the pin 50 depicted in FIGS. 5A and 5B that can be inserted through the cavity wall, attached to the wall, and subsequently urged away from the cavity to create a procedural space within the cavity.

[0080] As shown in FIGS. 5A and 5B, each pin 50 (also referred to herein as a “needle”) has a distal end having a needle tip 54 and two leaves or toggle-like components 52A, 52B that are each pivotally attached to the pin 50 such that the

leaves 52A, 52B can move between a collapsed position as shown in FIG. 5A and a deployed position as shown in FIG. 5B. In the collapsed position depicted in FIG. 5A, each of the leaves 52A, 52B are disposed in a position parallel to the length of the pin 50. In the deployed position depicted in FIG. 5B, each of the leaves 52A, 52B are disposed in a position perpendicular to the length of the pin 50.

[0081] In an alternative embodiment, any known toggle-like or attachment component can be provided near the distal end of the pin 50 to allow for insertion of the pin 50 through the cavity wall 56 and then capture of the interior portion of the wall while the pin 50 is being urged away from the cavity to create space within the cavity.

[0082] In use as best shown in FIGS. 5C and 5D, at least two pins or needles 50 are positioned in the cavity wall 56 such that the pins 50 are attached to the wall 56 and then can be urged away from the cavity 58 in the direction of the arrows in FIG. 5A to provide procedural space within the cavity 58. In one embodiment, each pin or needle 50 is inserted into the cavity wall 56 along the axis indicated by the letter A in FIG. 5C while the leaves 52A, 52B are in the collapsed position. Once the leaves 52A, 52B are inserted through the wall 56 and into the body cavity, the leaves 52A, 52B are moved into the deployed position as shown in FIG. 5B (and in FIGS. 5C and 5D). Each pin 50 can then be urged or moved in an outward direction (away from the patient) until the leaves 52A, 52B are in contact with the wall 56. According to one embodiment, sufficient force is applied to the pin 50 such that the leaves 52A, 52B can support the wall 56 and maintain an open cavity configuration, wherein the cavity wall 56 is urged away from the organs within the cavity, as shown in FIG. 5C.

[0083] In one embodiment, the force applied to the pin 50 or pins 50 is a manual force applied by the surgeon or assistant pulling on the pins with her or his hands. Alternatively, the force applied is a mechanical force provided by a device or by attaching the pins 50 to a stationary device.

[0084] An alternative embodiment of an externally-supported wall retention system is provided in FIGS. 6A and 6B. In this embodiment, each of the pins 60 operate in a similar fashion as the pins 50 shown in FIGS. 5A-5D. That is, the pins 60 are attached to the cavity wall and urged to pull the wall away from the cavity to provide procedural space within the cavity. However, in contrast to the pins 50 described above, each pin 60 of FIGS. 6A and 6B is not inserted into the cavity and attached to the inner wall of the cavity. Instead, each pin 60 has an attachment component 62 that can be attached to an external portion of the patient outside the body cavity. That is, the attachment component 62 can attach to an external portion 64 of the cavity wall.

[0085] In one embodiment, the attachment component 62 is a “grasper” that attaches to the external portion 64 of the cavity wall 66 by grasping the external portion 64. Alternatively, the attachment component 62 has barbs or other components that can be inserted partially into the external portion 64 of the wall 66. In a further alternative, the attachment component 62 has an adhesive that is used to attach the component 62 to the wall 66. In use, once the attachment component 62 is attached to the wall 66 as shown in FIG. 6B, each pin 60 is urged away from the patient in the same fashion described above such that the pins 60 urge the wall 64 away from the body and thereby maintain an open cavity space as shown in FIG. 6A.

[0086] It is understood that many different medical devices, components, and procedures can be used in conjunction with

the various externally-supported wall retention embodiments as shown in FIGS. 5A-5D and 6A-6B, including the positionable in vivo devices and various robotic devices and procedures described in the various applications incorporated by reference above. That is, the various wall retention device embodiments can be used to provide and/or maintain procedural space in a body cavity such that any type procedure or related device for use in a body cavity can be used in the space, including the various devices and procedures disclosed and incorporated by reference above.

[0087] FIGS. 7A-8B depict further exemplary implementations of externally-supported wall retention and device positioning systems and devices that create and/or maintain a procedural space in a body cavity while also providing for positioning one or more medical devices within the body cavity.

[0088] FIGS. 7A-7D depict an embodiment of an externally-supported wall retention and device positioning system that provides for both maintaining the open configuration of the surgical cavity and for positioning a medical device within the cavity. In one implementation, the system as depicted provides for positioning one or more medical devices along an interior wall of the cavity. As shown in FIG. 7A, the device or system 70 has two or more modular components 72 (also referred to herein as “rail modules”) that are hingedly coupled to each other. According to one embodiment, each of the modular components 72 has at least one magnet 74 disposed therein, as best shown in FIGS. 7A and 7C. Alternatively, each of the modular components 72 has at least one attachment point 76 to which a pin or needle 78 can attach, as best shown in FIG. 7D.

[0089] The device 70 as shown in FIG. 7A is configured such that each of the modular components 72 can be inserted through a small incision or a trocar-like tube into the surgical cavity. That is, the device 70 can be configured in an elongate shape such that its profile is small enough to be inserted through such an incision or tube.

[0090] After insertion, the modular components 72 of the device 70 are positioned against the interior of the cavity wall 84. In one embodiment, the device 70 is positioned against the wall 84 using exterior magnets 80 positioned outside the cavity as shown in FIGS. 7A and 7B. In one embodiment as shown, the magnets 80 are positioned in handles 82. This approach could provide a method for non-insufflating NOTES procedures if multiple devices 70 are positioned along the cavity wall 84. That is, it is possible to use this embodiment to create and/or maintain a procedural space in a body cavity without insufflation. The use of multiple modules 72 allows for the implementation of multiple magnets or needles for attachment to the cavity wall. This provides for a stronger attachment because the force applied by the multiple magnets to create a procedural space is greater than that created by one or two magnets.

[0091] Alternatively, the device 70 is positioned against the wall using exterior pins or needles 78, as shown in FIG. 7D.

[0092] According to one alternative embodiment, a modular component 100 similar to those disclosed in FIGS. 7A-7D is shown in FIGS. 8A-8B that is configured to receive one or more medical devices along track or mating components in the modular components. Each module 100 in this embodiment has at least one attachment magnet 112 and one or more tracks or mating components 118 with which a robotic device 114 can moveably mate using a set of wheels or cogs 116 and along which the device 114 can move. Thus, two or more

modular components 100 can be connected to each other to create a “railway” that one or more medical devices can traverse to move around the procedural cavity (similar to the set of modules as shown in FIG. 7A).

[0093] Each module 100 as shown in FIG. 8A has at least one magnet 112 associated with or disposed within the module 100. Further, each module 100 has a mating component 118 associated with or defined by the module 100. A medical device 114 can be coupled with the rail module 100 by the mating component 116 on the device 114. In one embodiment as shown, the mating component 116 on the device 114 is a wheel or cog that can couple with the rail 118 on the module 100. In one embodiment, the device 114 can be maintained in a substantially fixed position such that the device 114 can move along the rail module 100 relative to the cavity. This module 100 can be positioned transversely or sagittally along the cavity wall. Alternatively, the module 100 can be positioned in any known fashion within the cavity to allow for transporting a medical device along a predetermined path. In a further embodiment, more than one module 100 is positioned within the cavity and coupled together (in a fashion similar to FIG. 7A) and the device 114 can be positioned within the coupled modules 100 so that the device 114 can traverse along the length of the coupled modules 100. Alternatively, more than one device can be placed along the coupled modules 100 or more than one set of coupled modules 100 can be positioned in the cavity.

[0094] One advantage of the multiple modules with multiple magnets is that the weight of the attached device can be distributed across multiple attachment points. Furthermore, if the device includes arms, this approach provides a more stabilized and distributed base for tissue manipulation forces.

[0095] It is understood that many different medical devices, components, and procedures can be used in conjunction with the various externally-supported wall retention and device positioning systems and device embodiments as shown in FIGS. 7A-8B, including the positionable in vivo devices and various robotic devices and procedures described in the various applications incorporated by reference above. That is, the various wall retention and device positioning embodiments can be used to provide and/or maintain procedural space in a body cavity while also providing for the positioning and/or attachment of one or more medical devices, such that any type of procedure or related device for use in a body cavity can be used and positioned in the space, including the various devices and procedures disclosed and incorporated by reference above.

[0096] FIGS. 9-12 depict exemplary implementations of device positioning systems and devices that provide for positioning one or more medical devices within the body cavity.

[0097] FIG. 9 depicts one embodiment of a modular “railed” device 140. In this embodiment, each module 141 has a hook or attachment component 142 that can attach to the cavity wall 144. In one embodiment as shown, each module 141 is attached to the wall 144 with a hook or similar attachment component 142 that penetrates the wall 144. Alternatively, each module 141 is attached to the wall using an adhesive. In a further alternative, each module 141 is attached to the wall by any known attachment method or device.

[0098] Each module 141 also has a track or mating component 148 that is capable of coupling with one or more medical devices. The coupling of each module 141 to each other or

positioning of the modules **141** adjacent to each other creates a positioning device **140** along which a medical device **146** can move or be positioned.

[0099] FIG. 10 depicts another embodiment of a positioning device **150**. Instead of attaching with an attachment component to a cavity wall **152**, this device **150** is supported in the cavity **162** using at least two legs or links **156** that are positioned along a bottom portion of the cavity to support the rail **158**. In the embodiment depicted in FIG. 10, the device attachment component is a rail **158** along which the medical device **154** can move or be positioned. Alternatively, the device attachment component can be any such component along which the one or more medical devices **154** can be positioned. In the embodiment depicted in FIG. 10, the device **150** has four legs **156** that create a swing-set-like structure. A medical device **154** can be moveably attached to the rail **158** such that the device **154** can move back and forth along the rail **158**.

[0100] In one alternative implementation, the railed device **150** can have robotic, or otherwise actuated, components. For example, the legs **156** can have actuators (not shown) that actuate the legs **156** to move such that the device **154** can be raised or lowered. In a further embodiment, the attachment point **160** where the medical device **154** is coupled to the rail **158** can be coupled to an actuator (not shown) such that the actuator can operate to move the device **154** along the rail **158**.

[0101] In accordance with another implementation, the railed device **150** can support a medical device **154** as shown and described above while also providing cavity space maintenance. That is, the device **150** can also provide support to hold the upper cavity wall away from the lower cavity wall and therefore maintain the procedural cavity space.

[0102] FIG. 11 depicts another embodiment of a medical device positioning or attachment device **130**. The device **130** has a wall attachment component **138** and a device attachment component **136**. The wall attachment component **138** as shown in FIG. 11 is a hook that attaches to the cavity wall **132**. Alternatively, the wall attachment component **138** can utilize an adhesive. In a further alternative, the wall attachment component **138** can be any known component for attaching to the cavity wall. Further, according to another implementation, attachment device **130** is made of a degradable material and thus need not be removed from the cavity wall after the procedure is completed.

[0103] The device attachment component **136** provides for removable attachment to a medical device **134**. In one embodiment, the device attachment component **136** is a magnet that removably couples to the medical device **134**. Alternatively, the attachment component **136** provides for a mechanical coupling with the medical device **134**. In a further alternative, the attachment component **136** provides for any type of attachment method or device to attach to the medical device **134** such that the device **134** can be removed. In one implementation, the device **134** can be removed and a second device can be attached. In a further implementation, more than one medical device **134** can be attached.

[0104] Another embodiment of a medical device attachment or positioning device is depicted in FIG. 12. In this embodiment, the medical device **172** is positioned against an interior cavity wall using two pins **174A**, **174B** inserted through the cavity wall and coupled to the device **172**. In one embodiment, these pins **174A**, **174B** are thin needles that require no suturing or recovery time. According to one implementation, the pins **174** can be known needles currently used

for amniocentesis and chorionic villi sampling. Alternatively, each pin **174A**, **174B** can be any pin-like or needle-like component capable of being inserted into the patient's body and coupled to the medical device **172** disposed within the patient's body. After insertion, the needles **174** are attached to the in vivo device **172**. In one embodiment, only one pin is attached, thereby allowing the device **172** to rotate about the single attachment point. Alternatively, two pins are inserted to hold the robot in position, with additional needles inserted as needed to move the robot to a different orientation. In another implementation, these attachment pins can also be used in conjunction with magnets to position and/or attach the device.

[0105] The use of attachment pins provides a stable attachment of the medical device to or near the cavity wall. In those embodiments in which the medical device is controlled by some form of exterior component, the pins can assist in ensuring the medical device is positioned near or adjacent to the exterior handle or other exterior component. Alternatively, the pin length is controlled or manipulated to provide a vertical degree-of-freedom that would allow the medical device to move up and down relative to the pin and/or the body cavity. Attachment or coupling of the pins to the device includes self-assembly techniques that include magnets at the pin tips or semi-autonomous connection with the medical device. Alternatively, the pins are attached through surgeon assistance in vivo using endoscopic tools or other medical devices.

[0106] In one method, the pin or pins are inserted into the patient's body and then the medical device or devices are coupled to the pin(s). In another embodiment, the medical device is positioned against the cavity wall prior to insertion of the pin(s), and the pin (or pins) is inserted such that the pin couples to the device during insertion. Alternatively, the pin (or pins) is first inserted and then the medical device is coupled to the pin.

[0107] According to one embodiment, the pins **174** described herein can be used to assist with the attachment or positioning of one or more medical devices within a body cavity of an obese patient in which the cavity wall **176** has a thickness that makes it difficult or impossible to use magnetic attachment devices or methods.

[0108] It is understood that many different medical devices, components, and procedures can be used in conjunction with the various device positioning embodiments as shown in FIGS. 9-12, including the positionable in vivo devices and various robotic devices and procedures described in the various applications incorporated by reference above. That is, the various device positioning embodiments can be used to provide for the positioning and/or attachment of one or more medical devices, such that any type of procedure or related device for use in a body cavity can be used and positioned in the space, including the various devices and procedures disclosed and incorporated by reference above.

[0109] FIGS. 13-20B depict exemplary implementations of device insertion and retraction devices.

[0110] FIG. 13 depicts an overtube **210**, according to one embodiment, for use in inserting a medical device into a patient's body and retracting the device from the body through the overtube. It is understood that the term "overtube" as used herein is intended to mean any medical procedural tube that is inserted into a patient and positioned such that further procedural devices can be inserted through the tube into the patient, retrieved through the tube from the

patient, and/or such that the further procedural devices can be operated inside the patient through the tube. Thus, “overtube” includes any tube that is inserted down the patient’s esophagus or through any incision or into any cavity and positioned such that other devices or instruments can be inserted into the patient’s body.

[0111] The overtube **210** as shown in FIG. **13** defines a device lumen **212** through which a medical device, such as a robotic device, can be passed. In addition, the overtube **210** also defines a wire lumen **14** through which an insertion wire **216** can be passed. In the embodiment depicted in FIG. **13**, the wire lumen **214** is defined in the outer wall **218** of the overtube **210**.

[0112] In use, the overtube **210** allows a user to pull a medical device through the overtube **210** from the proximal end **220** to the distal end **222** of the overtube **10**. That is, according to one implementation, the insertion wire **216** is inserted through the device lumen **212** and also inserted through the wire lumen **214** as depicted in FIG. **13**, such that the proximal end **224** of the wire **216** and the distal end **226** of the wire **216** both extend from the proximal end **220** of the overtube **210**.

[0113] The proximal end **224** of the wire **216** is then attached to the device (not shown) to be pulled through the overtube **210**. Alternatively, the wire **216** is attached to the device prior to positioning the wire **216** in the tube **210**. The distal end **226** of the wire **216** is then pulled by the user such that the wire moves in the direction indicated by the arrows A, B, and C, thereby resulting in the device being pulled toward the distal end **222** of the overtube **210**.

[0114] In one implementation, the wire **216** is a braided metal cable. Alternatively, the wire **216** is a nylon string. In yet another alternative, the wire can be any such wire, tether, thread, cord, or any other type of elongate flexible material that can be used in medical procedures such as the methods described herein.

[0115] According to one embodiment, the overtube **210** is a flexible polyethylene tube. Alternatively, the overtube can be any tube, cannula, or other type of hollow elongate object having a lumen that can be used for insertion of devices into, or use of devices within, a patient’s body.

[0116] FIG. **14** depicts one method and device for attachment of a wire **230** to a medical device **232** for device insertion. In this embodiment, the wire **230** has an attachment component **234** in the form of a ball coupled to the proximal end **236** of the wire **230**. In use, the clamp **238** on the distal end **240** of the device **232** is clamped onto or otherwise coupled with the ball **234** on the wire **230**. Upon attachment of the device **232** to the wire **230** via attachment of the clamp **238** to the ball **234**, the user can pull the distal end **242** of the wire **230** to move the wire **230** as shown by the arrows A, B, and C to thereby pull the device **232** toward the distal end **244** of the overtube **246**, which is the direction depicted by arrow D. Once the device **232** has reached the desired position, the user can operate the clamp **238** to release the ball **234** such that the device **232** can then be used to perform the intended procedure.

[0117] According to the embodiment depicted in FIG. **14** and discussed above, the attachment component **234** is a ball. Alternatively, the attachment component is a hook that can hook to a portion or component of the medical device. In another embodiment, the attachment component is a loop-shaped portion of string or cable that can be looped or otherwise coupled with an appropriate mating component on the

medical device. Alternatively, the component **234** can be any shape or any component that allows for easy attachment to the medical device **232**. In a further alternative, the attachment component **234** is a magnet that can magnetically couple with the device **232**. In yet another alternative, the attachment component can be any component that can be used to removably attach the wire **230** to a medical device **232**.

[0118] FIG. **15** depicts an alternative embodiment of an overtube **250** for insertion or delivery of a medical device. In this implementation, the overtube **250** has a protrusion **252** that protrudes or extends from the distal end **254** of the tube **250**. The term “protrusion” shall encompass, for purposes of this application, any portion or component of the overtube **250**, or a separate component, such as a lip or an extension, that protrudes or extends from the distal end **254** of the tube **250**. According to one embodiment, the wire lumen **256** is defined in the protrusion **252** as shown in FIG. **15**.

[0119] In use, the protrusion **252** as shown in FIG. **15** facilitates positioning of the medical device **258**, which can be a robotic device according to one embodiment. That is, as the wire **260** is pulled as shown by arrow A, the wire **260** pulls the device **258** toward the protrusion **252** on the distal end **254** of the tube **250**. Because the protrusion **252** extends beyond the distal end **254** of the tube, the device **258** exits from the device lumen **262** as it approaches the protrusion **252** and thus is pulled into or positioned in the target or procedural site in the patient’s body. In an alternative step, a magnetic handle **264** or other magnetic component can be positioned externally to the body cavity and used to further position the device **258**. Alternatively, any external positioning component can be utilized in conjunction with the overtube **250** to facilitate positioning the device as desired and/or with precision.

[0120] A further alternative implementation is depicted in FIG. **16**, in which the overtube **270** has a protrusion **272** having an indentation or device receiving component (also referred to as a “docking component”) **274** that is configured to receive a medical device **276** such that the device **276** can couple with or “dock” to the protrusion **272** or to the end of the overtube **270** for final positioning or even during the entire or a significant portion of the medical procedure. In this implementation, the coupling can be accomplished with magnets or mechanical attachment components such as claims or screws. In yet another embodiment, the medical device docks to the protrusion or to the overtube itself to charge onboard batteries, or to store a biopsy sample, or to exchange end-effectors.

[0121] Alternatively, the protrusion can be a deployable protrusion. For example, one embodiment of a deployable protrusion **282** is depicted in FIGS. **17A** and **17B**. In this embodiment, the protrusion **282** is movably coupled to the overtube **280** and can unfold using a spring **283**, such as a torsional spring. FIG. **17A** depicts the protrusion **282** in the undeployed position in which the torsional spring **283** is configured to urge the protrusion **282** into the deployed position but is retained in the undeployed or closed position by retention component **287**. The retention component **287** can be a hook, latch, or any other actuatable retention component that can be actuated to release the protrusion **282** from the undeployed position. FIG. **17B** depicts the protrusion **282** at a position between the undeployed position and the deployed position and FIG. **17C** depicts the protrusion **282** in the fully deployed position.

[0122] In use, the protrusion **282** can be maintained in the undeployed position during insertion. That is, according to one embodiment, the protrusion **282** is not be deployed until



the overtube **280** is inserted into the patient. At this point, the protrusion **282** can then be deployed through a series of actuators or cables. For example, according to one embodiment as shown in FIG. **17A**, the overtube **280** has a wire or cable **285** coupled to the retention component **287** such that the wire or cable **285** can be pulled in the direction of arrow **A** to actuate the retention component **287** to release the protrusion **282**. Once released, the force applied to the protrusion **282** by the torsional spring **283** causes the protrusion **282** to move toward the deployed position as shown in FIG. **17B**. FIG. **17C** depicts the protrusion **282** after it has reached the deployed position.

[**0123**] Alternatively, the overtube can have any other kind of overtube positioning component at its distal end. That is, any component that facilitates exit of the device from the device lumen and/or positioning of the device at the target area can be used with the overtube. For example, it is understood that the concept of this positioning component shall encompass any hole or gap defined in the tube that provides for positioning of the device in the same fashion that the protrusion accomplishes such positioning.

[**0124**] In another embodiment, FIG. **18** depicts a method and device for retracting a device from an interior portion of a patient's body. More specifically, FIG. **18** depicts a retraction wire **290** that can be inserted through the device lumen **292** of the overtube **294** and into the procedural site. In use, the user can operate the clamp **295** or some other type of attachment component of the medical device **296** to attach to the wire attachment component **298**, which in this embodiment is a ball. Alternatively, the wire attachment component **298** can be any such attachment component as described above, including a magnet or any other component that provides for attachment of the wire **290** and the device **296**. Once the device **296** is attached to the wire **290**, the user pulls the wire **290** toward the proximal end **299** of the tube **294** (in the direction indicated by arrow **A**), thereby retracting the device **296** from the procedural site.

[**0125**] FIGS. **19A**, **19B**, and **19C** depict profiles of three different over tubes **300**, **302**, and **304**, according to three different embodiments. Each overtube has an orientation component **306**, **308**, and **310** that cooperates with the device to be inserted through the overtube **300**, **302**, or **304** to orient the device. More specifically, according to the embodiments depicted in FIGS. **19A**, **19B**, and **19C**, the orientation component in each figure is configured to mate or couple with the body of the device being inserted through the overtube **300**, **302**, or **304** such that the device is forced to be oriented in a particular fashion as it passes through the overtube **300**, **302**, **304**, thereby facilitating the proper orientation of the device during insertion and/or positioning.

[**0126**] It is understood that FIGS. **19A**, **19B**, and **19C** are merely exemplary, and that any orientation component configuration can be provided so long as it results in mating with the device to be inserted such that the device can be provided with the proper orientation.

[**0127**] FIGS. **20A** and **20B** depict another method and device for inserting and retracting a medical device, according to one embodiment. In this embodiment, the connection component **320** (also referred to as a "tether") connecting the medical device **322** to the external controller (not shown) is disposed through the wire lumen **324** and the device lumen **326** of the overtube **328** as shown in FIG. **20A** and performs in the same fashion as the embodiments of the insertion wires described above. That is, in use, the tether **320** can be pulled

as indicated by the arrow **A** in FIG. **20A** such that the device (not shown) attached to the opposite end (not shown) of the tether **320** is urged toward the distal end **330** of the overtube **328** until it exits the device lumen **326** of the overtube **328** and is positioned at the procedural site, as depicted in FIG. **20B**.

[**0128**] In this implementation as shown in FIGS. **20A** and **20B**, the tether **320** can be electrical cabling, hydraulic or pneumatic lines, or suction and irrigation lines, any of which can supply further power or actuation to the device **322**.

[**0129**] It is understood that in certain embodiments, the overtube is a relatively stiff tube that exhibits some flexibility for facilitating insertion into the patient. In alternative embodiments, the overtube is designed to be stiff enough to provide sufficient rigidity perpendicular to the primary axis of the tube for operation of hydraulics or pneumatic lines. Furthermore, it is understood that positioning the tether in a wire lumen or tether lumen in the overtube helps keep the overtube inner lumen free from tethers, thereby facilitating insertion of various devices through the overtube.

[**0130**] It is understood that many different medical devices, components, and procedures can be used in conjunction with the various device insertion, positioning, and retraction embodiments as shown in FIGS. **13-20B**, including the positionable in vivo devices and various robotic devices and procedures described in the various applications incorporated by reference above. That is, the various device insertion, positioning, and retraction embodiments can be used to provide for the insertion, positioning, and/or retraction of one or more medical devices, such that any type of procedure or related device for use in a body cavity can be inserted into, positioned within, and/or retracted from the space, including the various devices and procedures disclosed and incorporated by reference above.

[**0131**] Although the present invention has been described with reference to preferred embodiments, persons skilled in the art will recognize that changes may be made in form and detail without departing from the spirit and scope of the invention.

What is claimed is:

1. A body cavity spatial support device, the device comprising:
  - (a) a first inflatable body configured to be disposed within a cavity of a patient's body; and
  - (b) a first inflation mechanism operably coupled to the first inflatable body.
2. The device of claim **1**, wherein the first inflatable body is inflatable into an expanded configuration.
3. The device of claim **2**, wherein the expanded configuration comprises a generally cylindrical shape.
4. The device of claim **2**, wherein the expanded configuration comprises a generally donut-like shape.
5. The device of claim **1**, further comprising a second inflatable body configured to be disposed within the cavity of the patient's body.
6. The device of claim **5**, wherein the first inflation mechanism is further operably coupled to the second inflatable body.
7. The device of claim **5**, further comprising a second inflation mechanism operably coupled to the second inflatable body.
8. The device of claim **1**, wherein the first inflation mechanism is operably coupled to the first inflatable body through a port, incision, or natural orifice of the patient.

**9.** A collapsible body cavity spatial support device, the device comprising:

- (a) a first link;
- (b) a second link hingedly coupled to the first link; and
- (c) a third link hingedly coupled to the second link, wherein the support device is configured to have a collapsed configuration and a deployed configuration.

**10.** The device of claim **9**, further comprising at least five additional links, wherein each of the five additional links is hingedly coupled to at least one of the first, second, third, or additional links.

**11.** The device of claim **9**, the deployed configuration defining a procedural space.

**12.** A delivery or removal device, comprising:

- (a) a tubular body;
- (b) a device lumen defined by the tubular body;
- (c) a wire lumen defined by the tubular body; and
- (d) a wire disposed through the device lumen and the wire lumen.

**13.** The device of claim **12**, wherein the device lumen further comprises a proximal device opening at a proximal end of the tubular body and a distal device opening at a distal end of the tubular body.

**14.** The device of claim **12**, wherein the wire lumen further comprises a proximal wire opening at a proximal end of the tubular body and a distal wire opening at a distal end of the tubular body.

**15.** The device of claim **12**, wherein the wire comprises an attachment component configured to be attachable to a medical device.

**16.** The device of claim **15**, wherein the attachment component is a ball.

**17.** The device of claim **12**, wherein the tubular body comprises protrusion at a distal end of the tubular body, wherein the protrusion further defines the wire lumen.

**18.** The device of claim **17**, wherein the protrusion is a deployable protrusion, the deployable protrusion comprising:

- (a) a pivotal connection coupling the deployable protrusion to the distal end of the tubular body;
- (b) a releasable retention component configured to retain the deployable protrusion in an undeployed position; and
- (c) a spring operably coupled to the deployable protrusion, the spring configured to urge the deployable protrusion toward a deployed position.

**19.** The device of claim **17**, wherein the protrusion further comprises a device receiving component configured to receive a medical device.

**20.** The device claim of **19**, wherein the device receiving component comprises at least one magnet configured to magnetically couple to the medical device, whereby the medical device releasably couples to the device receiving component.

\* \* \* \* \*