



US 20090032924A1

(19) **United States**

(12) **Patent Application Publication**
STARK

(10) **Pub. No.: US 2009/0032924 A1**

(43) **Pub. Date: Feb. 5, 2009**

(54) **HERMETICALLY SEALED PACKAGE WITH WINDOW**

(52) **U.S. Cl. 257/680; 438/116; 257/E23.18; 257/E21.5**

(76) **Inventor: DAVID H. STARK, EVERGREEN, CO (US)**

(57) **ABSTRACT**

Correspondence Address:
HOWISON & ARNOTT, L.L.P
P.O. BOX 741715
DALLAS, TX 75374-1715 (US)

A method for manufacturing a cover assembly including a transparent window portion and a frame of gas-impervious material that can be hermetically attached to a micro-device package base to form a hermetically sealed micro-device package. First a frame of gas-impervious material is provided the frame having a continuous sidewall defining a frame aperture there through. The sidewall includes a frame seal-ring area circumscribing the frame aperture. A sheet of a transparent material is also provided, the sheet having a window portion defined thereupon. The window portion has finished top and bottom surfaces. A sheet seal-ring area is prepared on the sheet, the sheet seal-ring area circumscribing the window portion. The frame is positioned against the sheet such that at least a portion of the frame seal-ring area and at least a portion of the sheet seal-ring area contact one another along a continuous junction region that circumscribes the window portion. The frame is pressed against the sheet with sufficient force to produce a predetermined contact pressure between the frame seal-ring area and the sheet seal-ring area along the junction region. The junction region is heated to produce a predetermined temperature along the junction region. The predetermined contact pressure and the predetermined temperature are maintained until a diffusion bond is formed between the frame and sheet all along the junction region.

(21) **Appl. No.: 11/773,354**

(22) **Filed: Jul. 3, 2007**

Related U.S. Application Data

(63) Continuation of application No. 10/880,166, filed on Jun. 29, 2004, now Pat. No. 7,238,546, which is a continuation of application No. 10/630,291, filed on Jul. 30, 2003, now Pat. No. 6,759,590, which is a continuation of application No. 10/104,315, filed on Mar. 22, 2002, now Pat. No. 6,627,814.

Publication Classification

(51) **Int. Cl.**
H01L 23/02 (2006.01)
H01L 21/52 (2006.01)

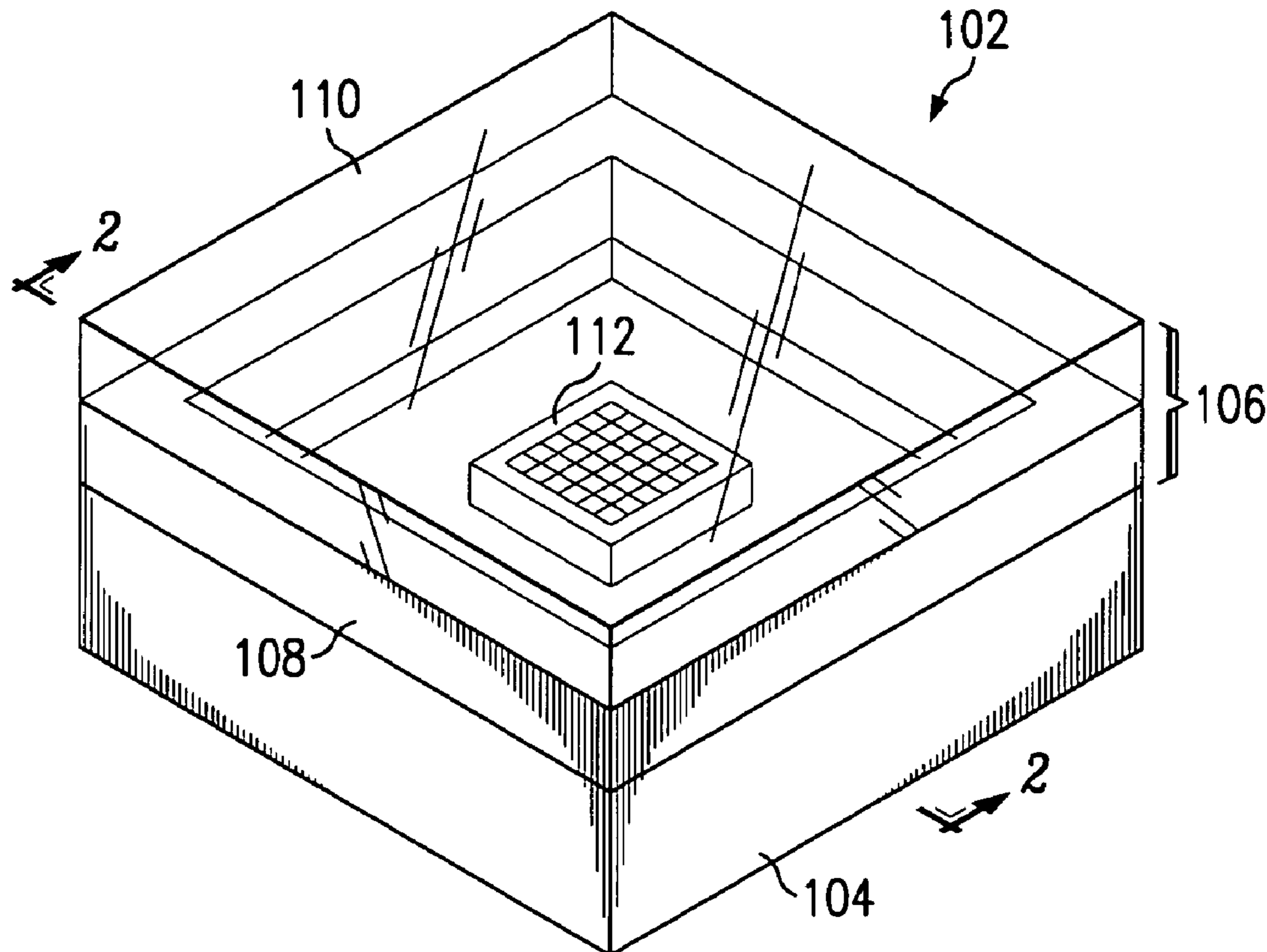

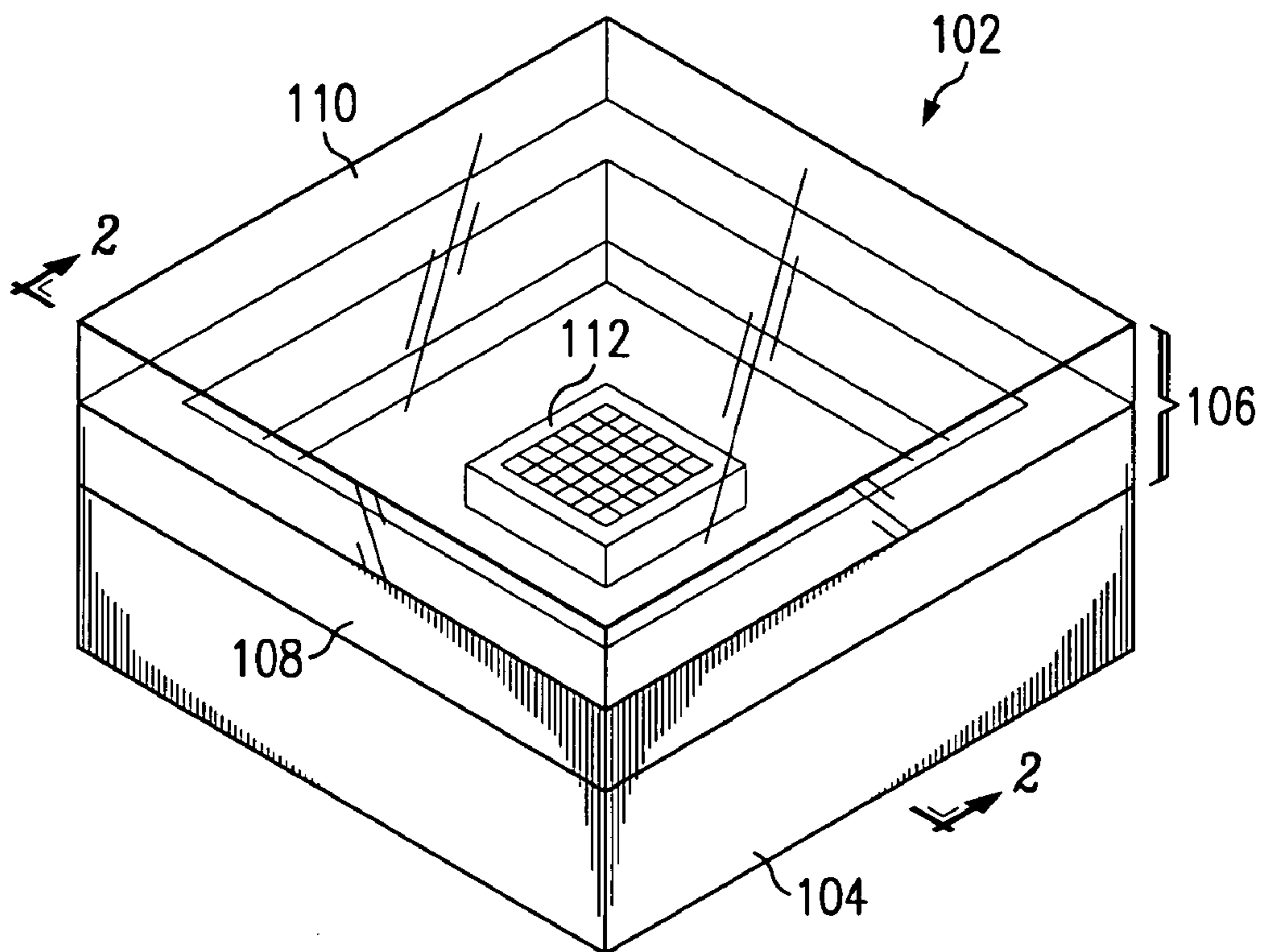

FIG. 1

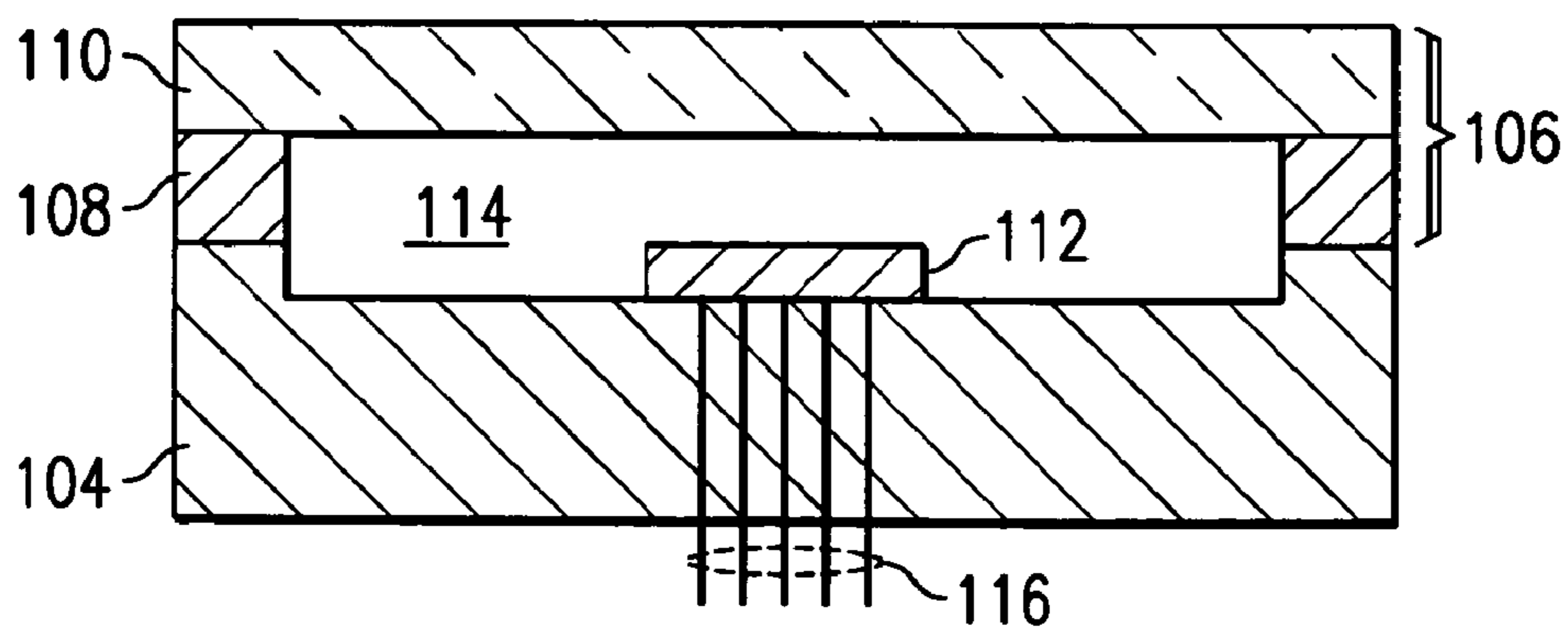

FIG. 2

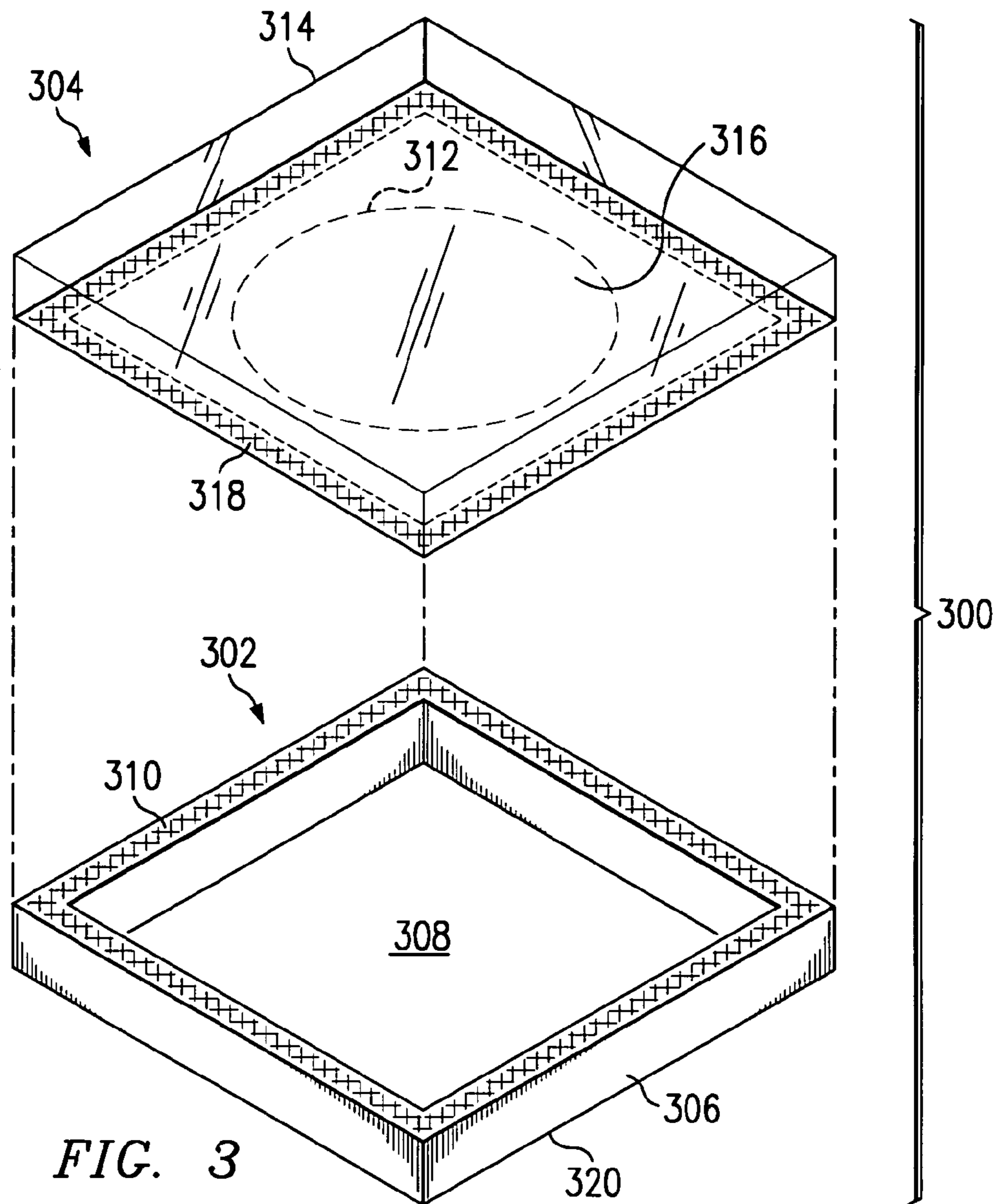

FIG. 3

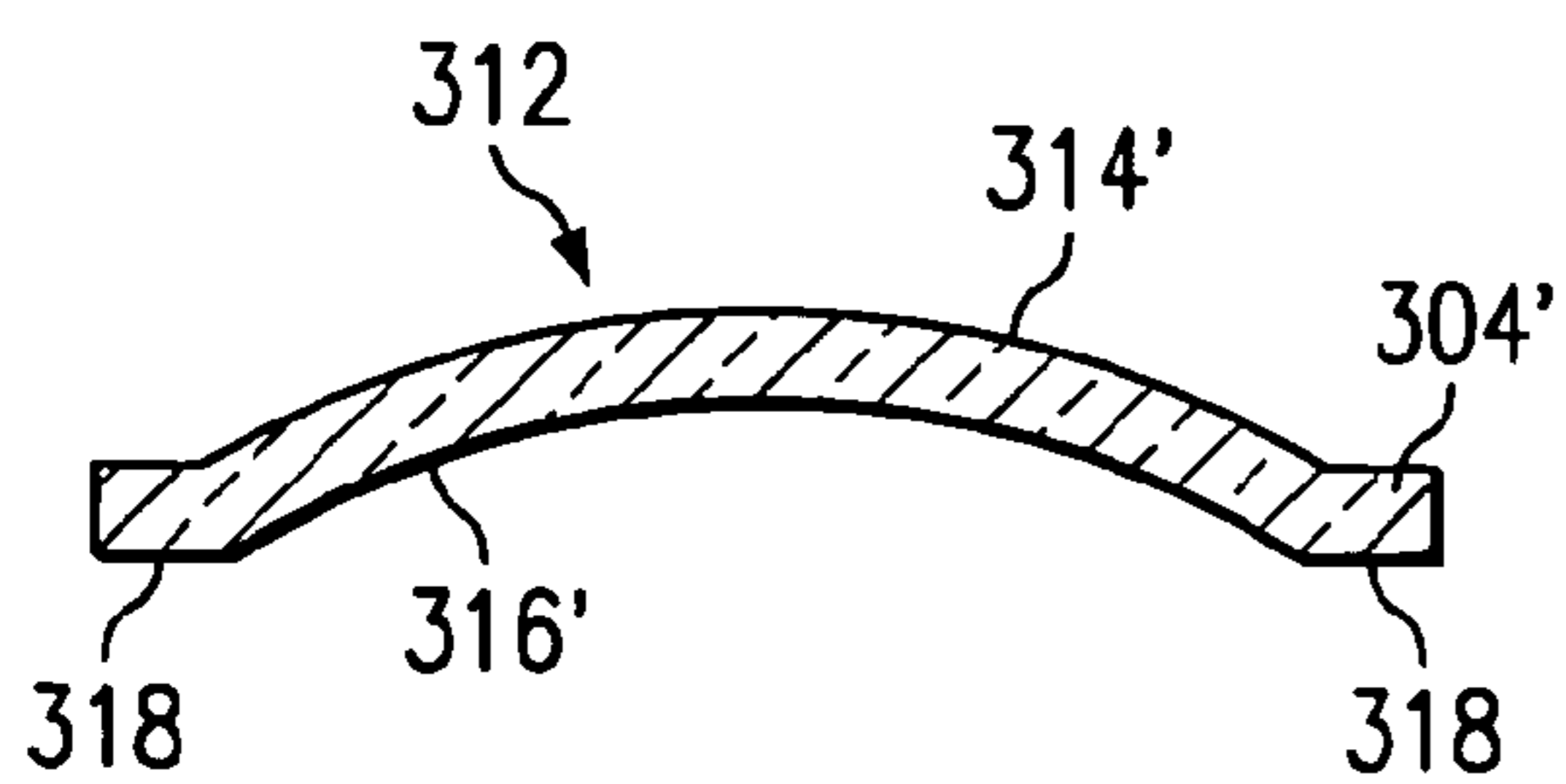

FIG. 4a

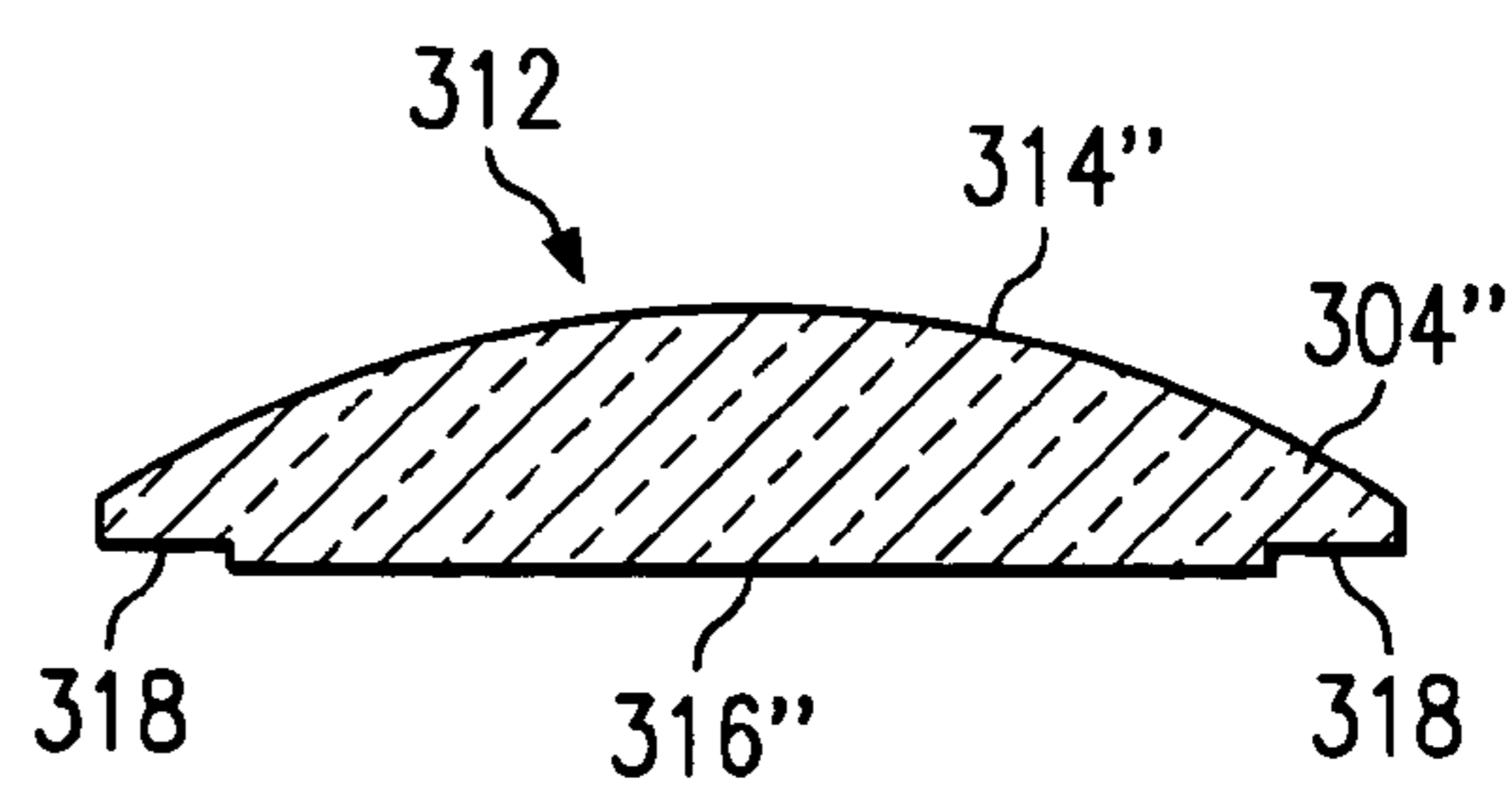

FIG. 4b

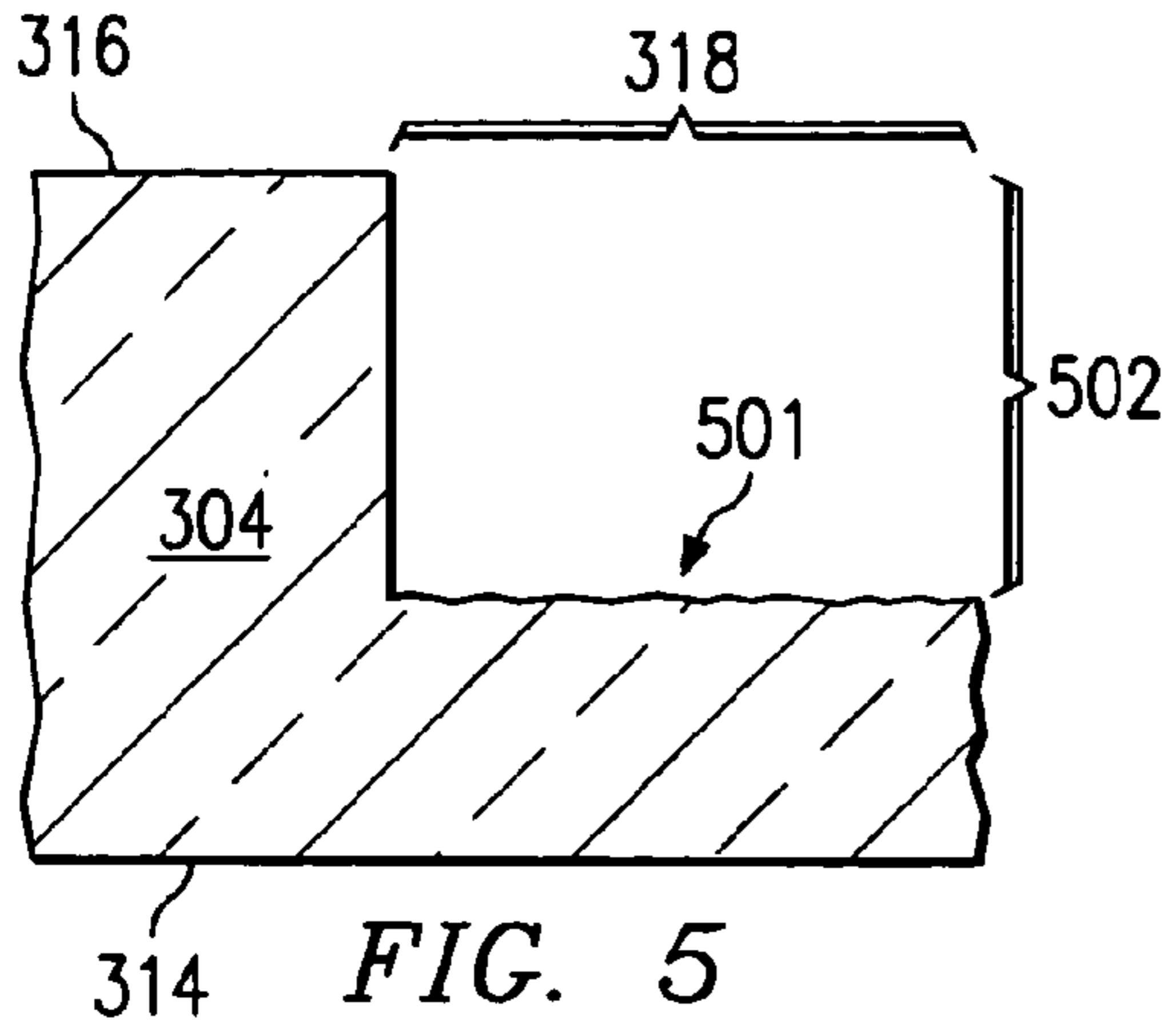

FIG. 5

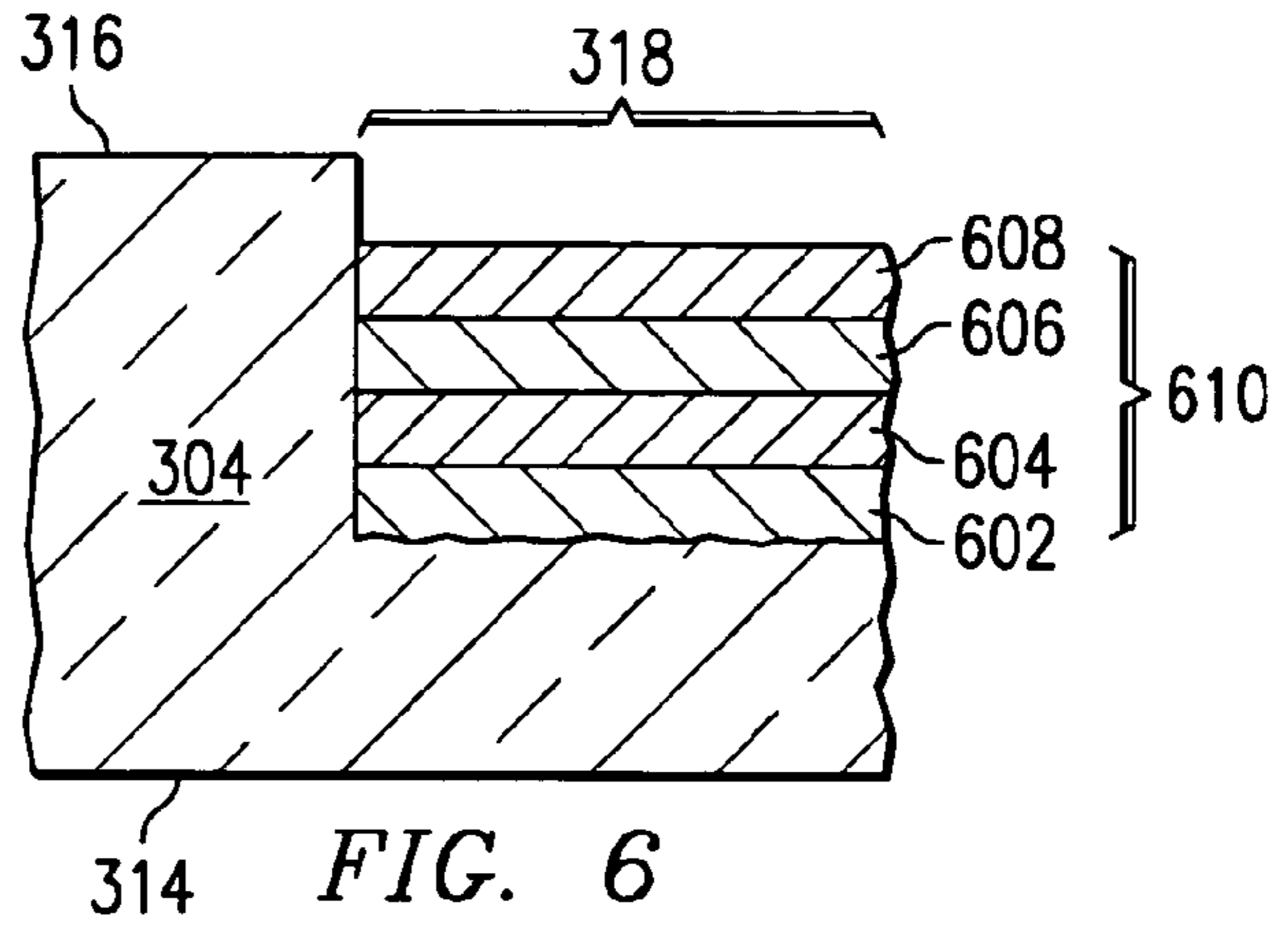

FIG. 6

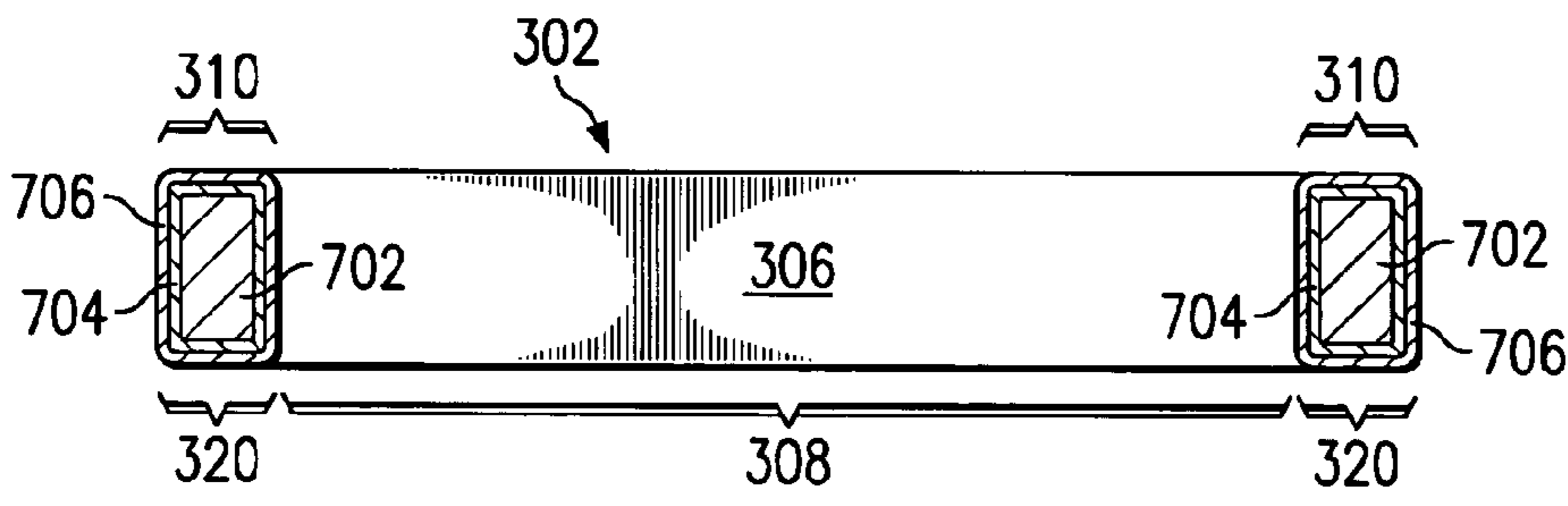

FIG. 7

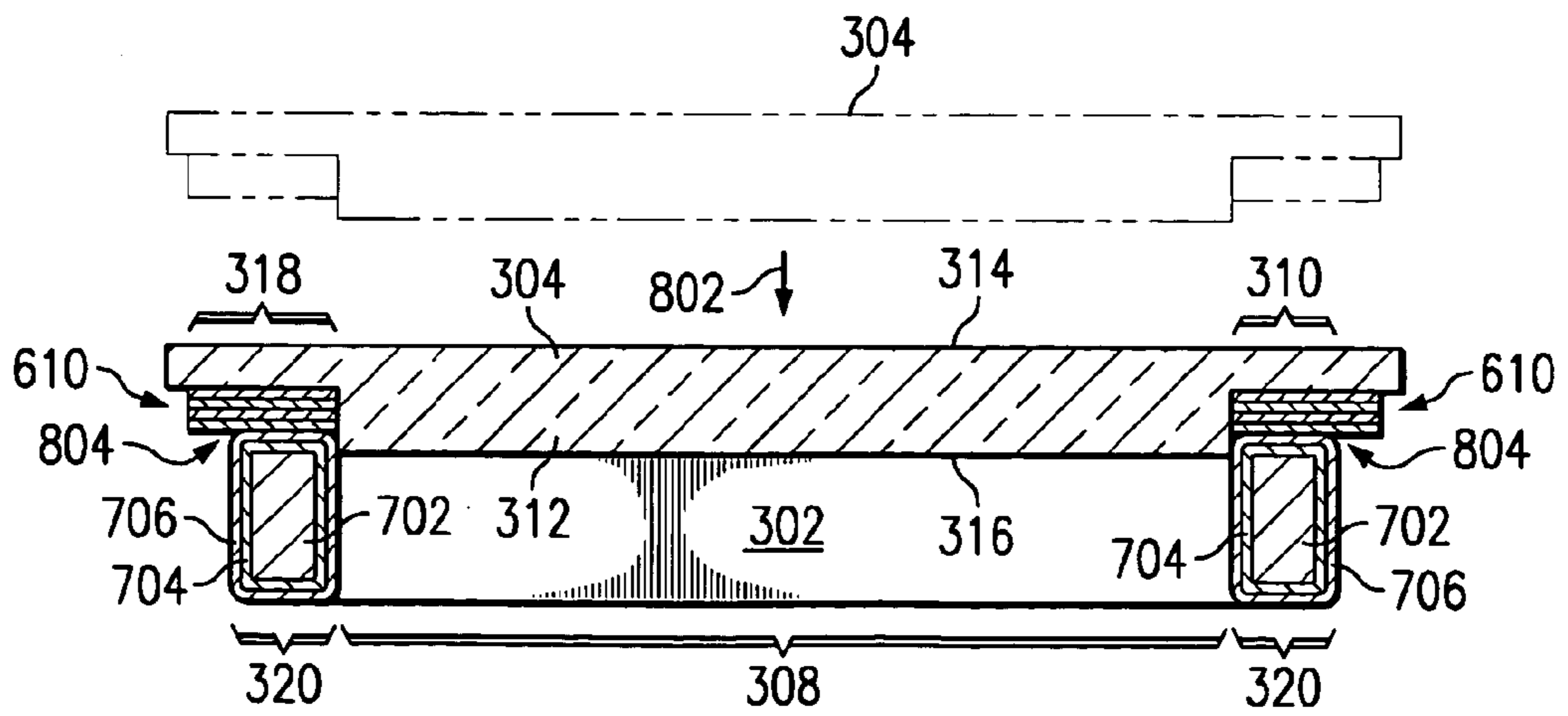

FIG. 8

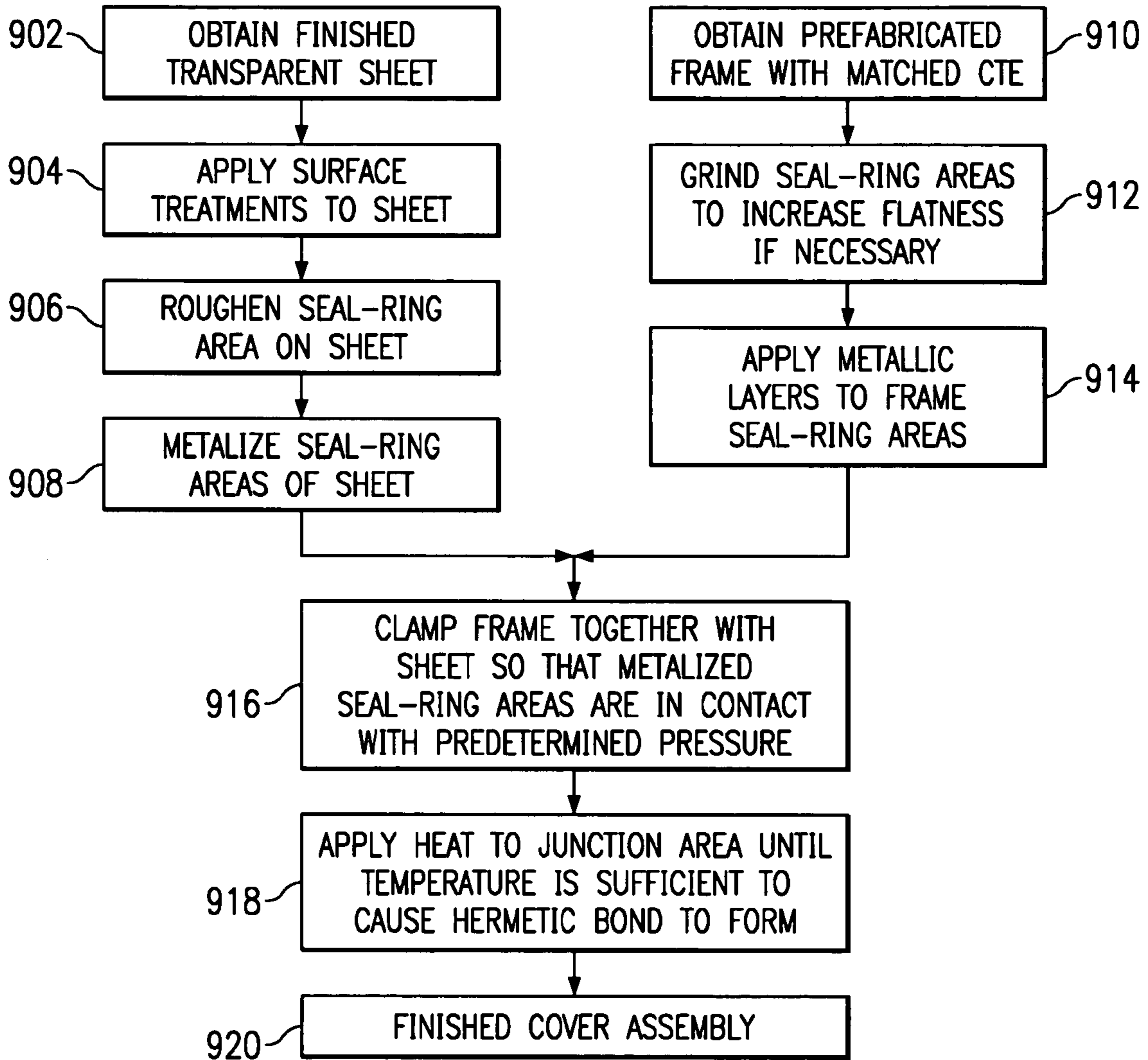

FIG. 9

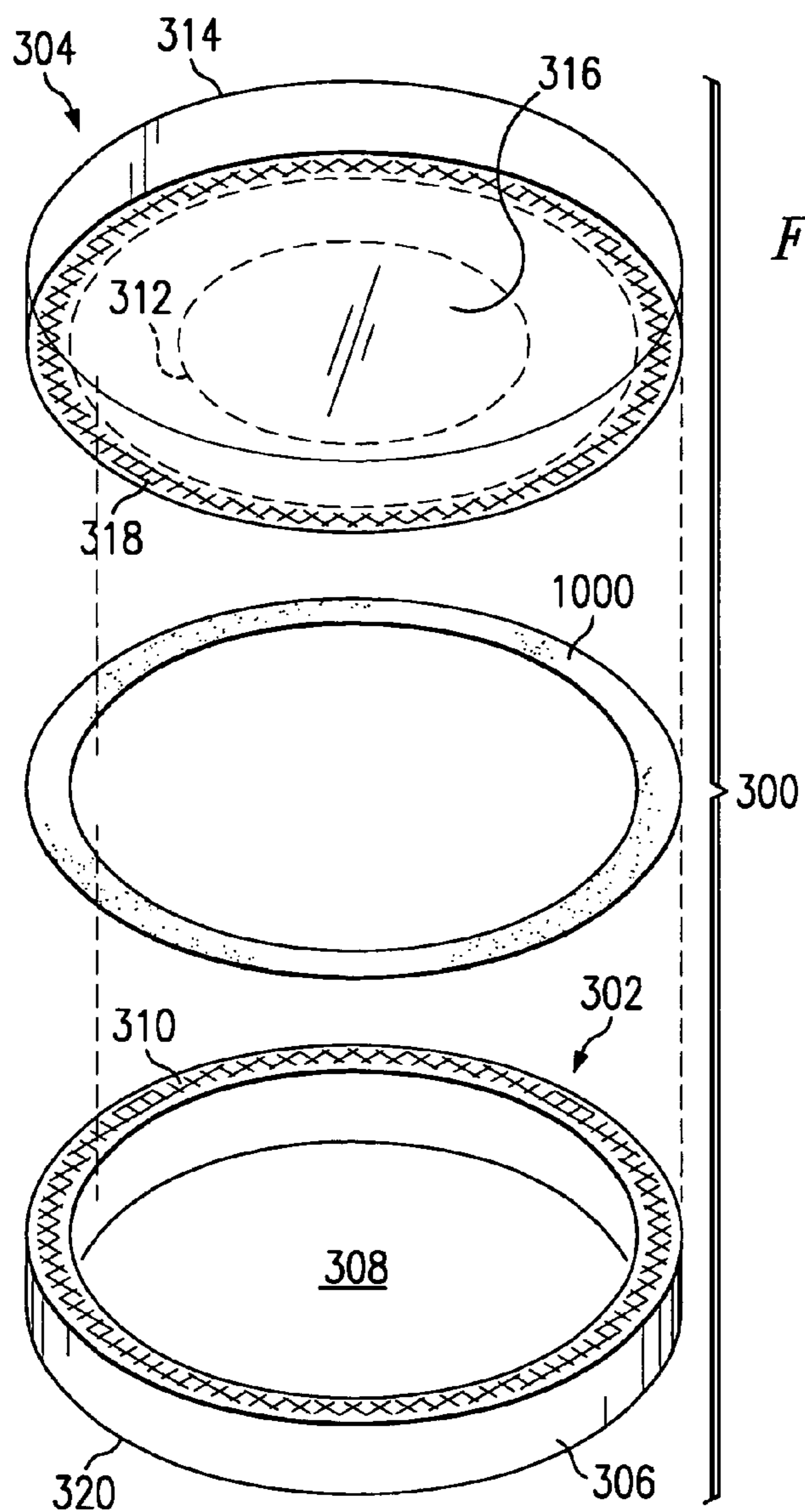

FIG. 10

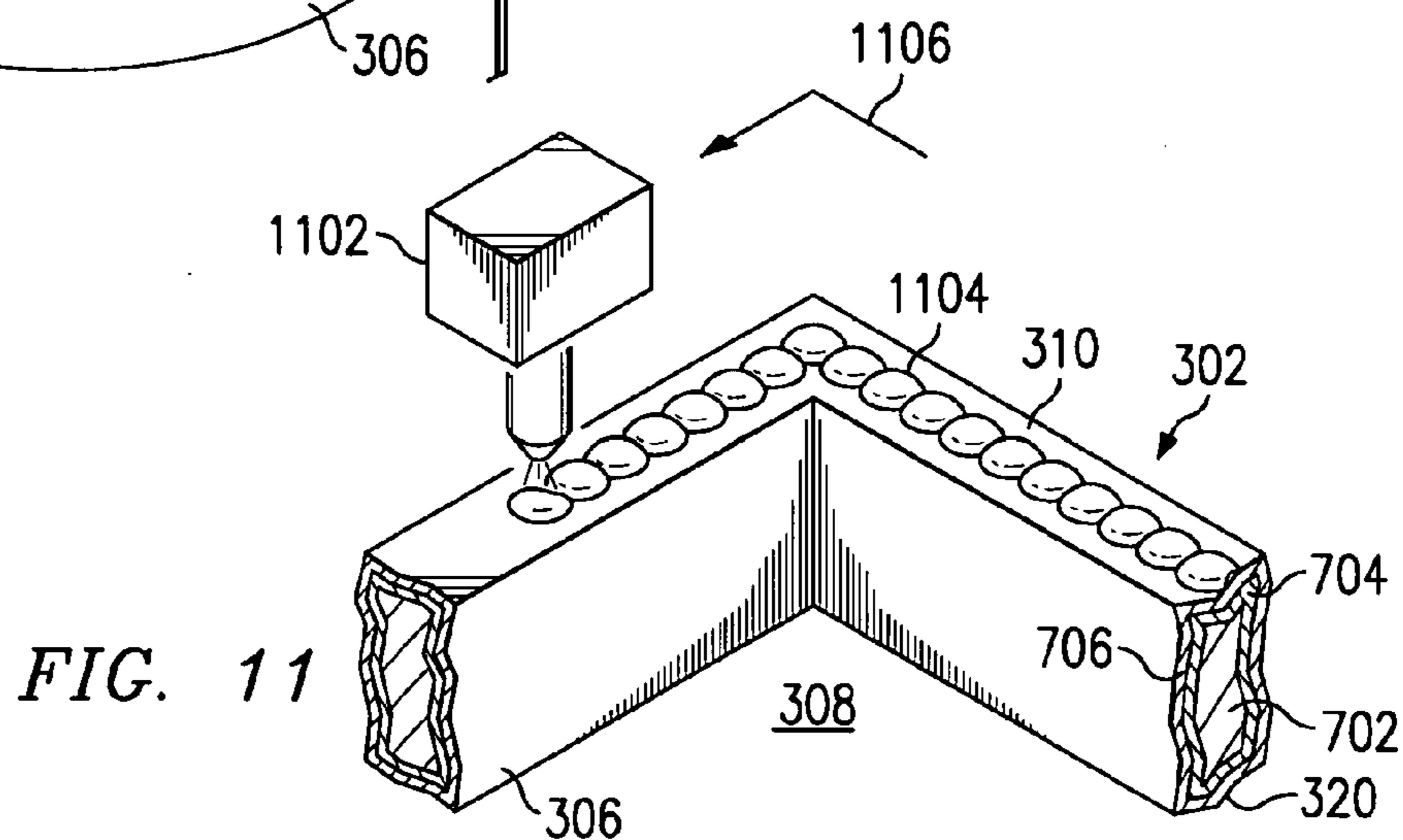

FIG. 11

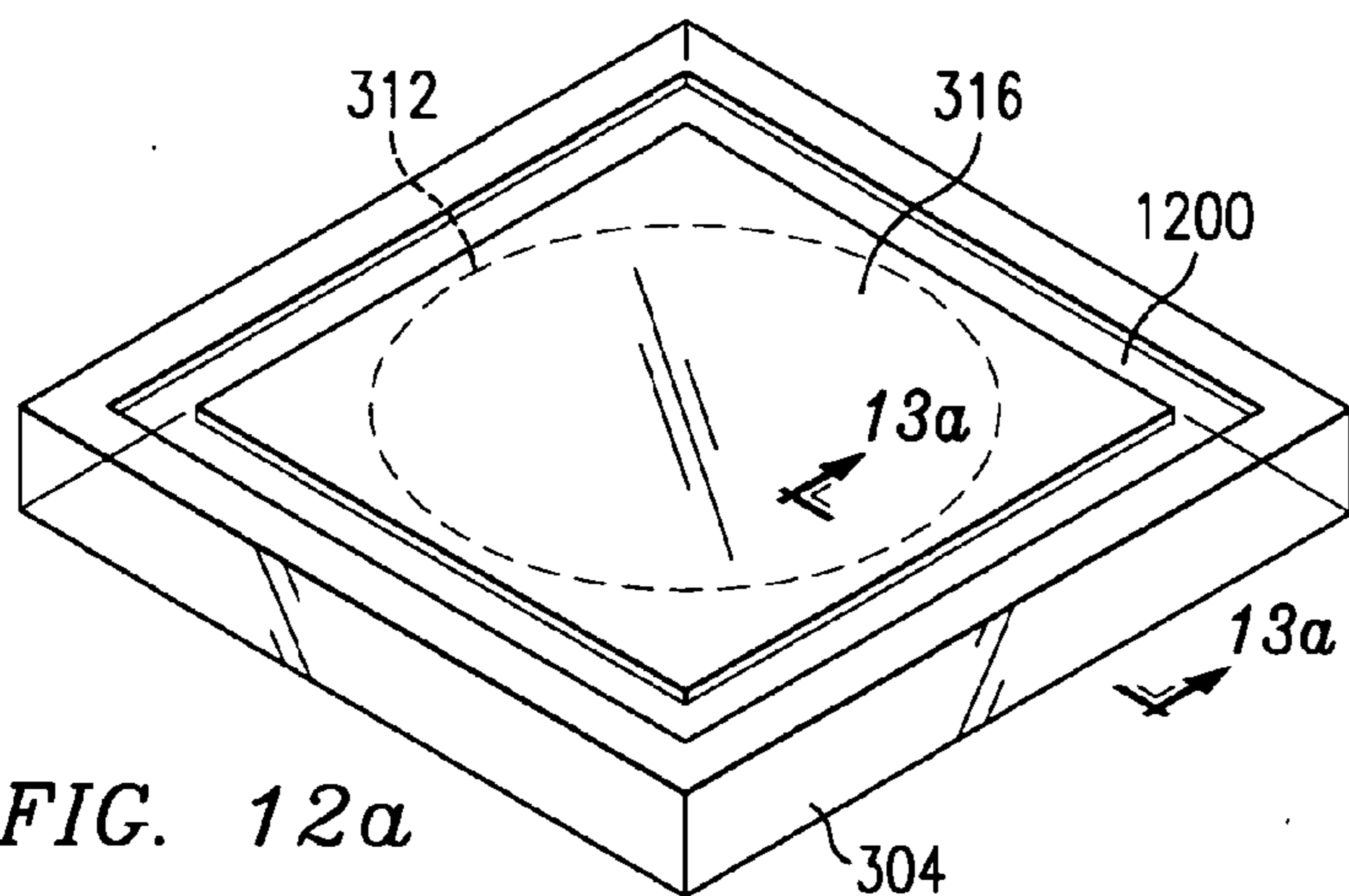

FIG. 12a

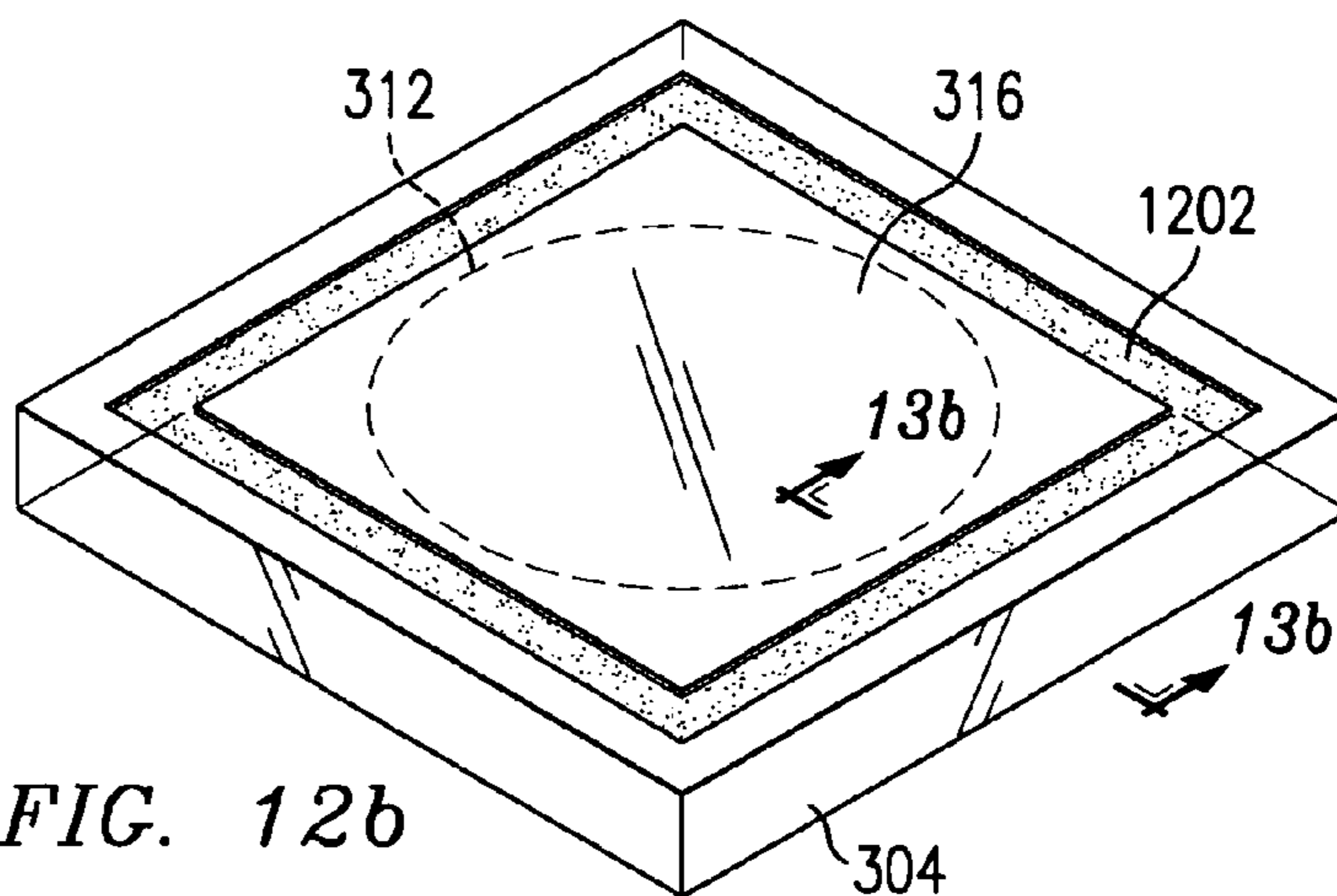

FIG. 12b

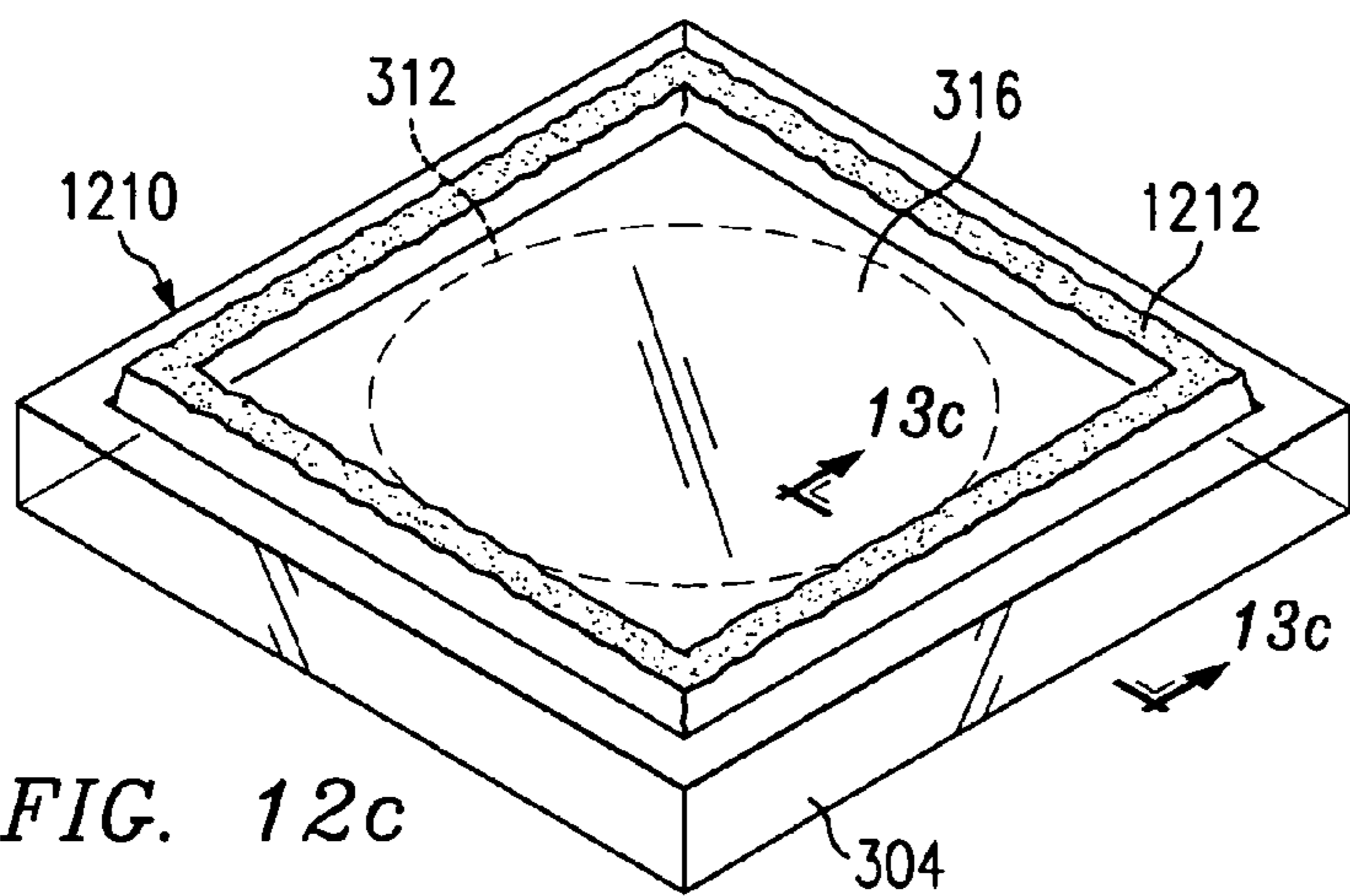

FIG. 12c

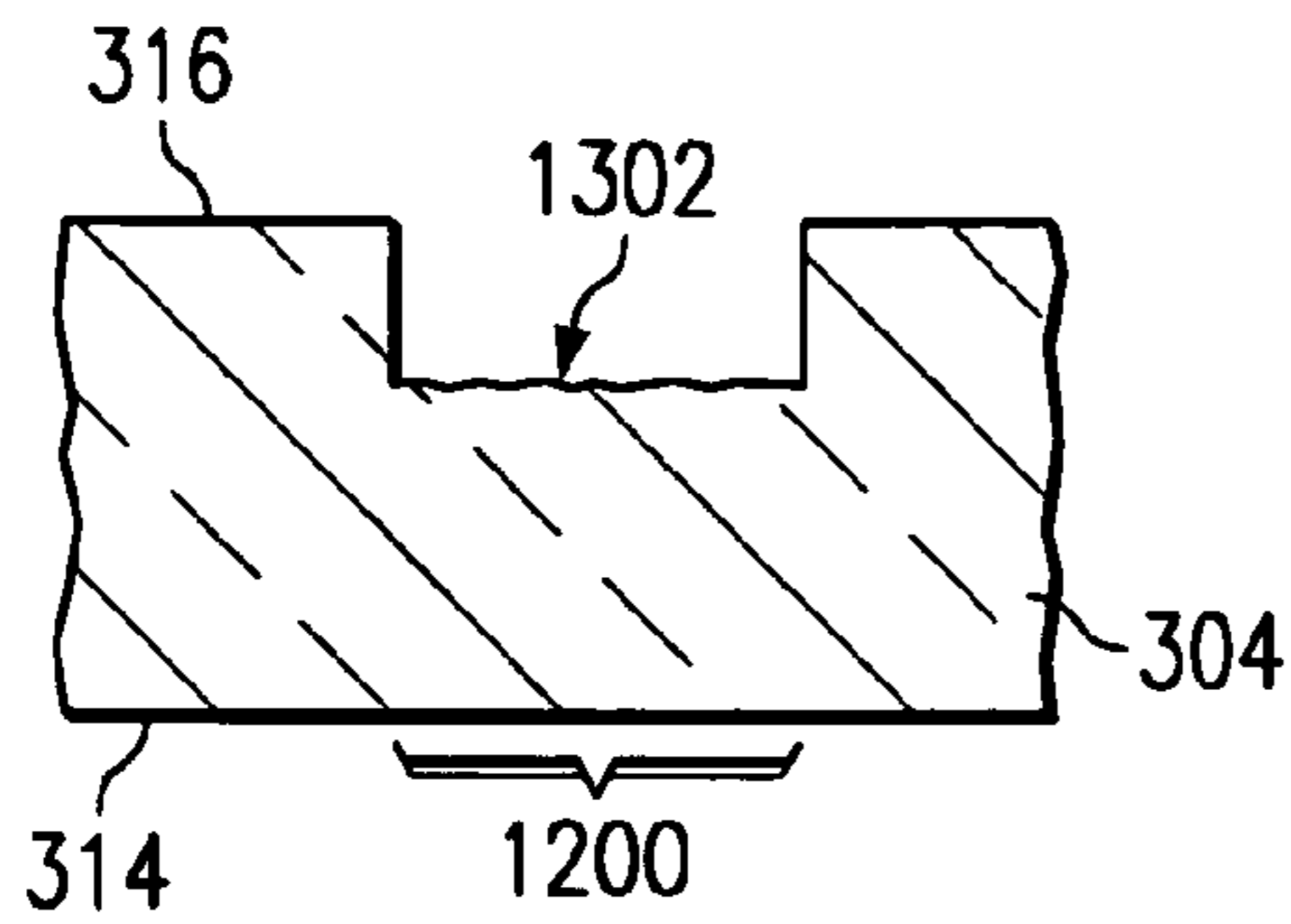

FIG. 13a

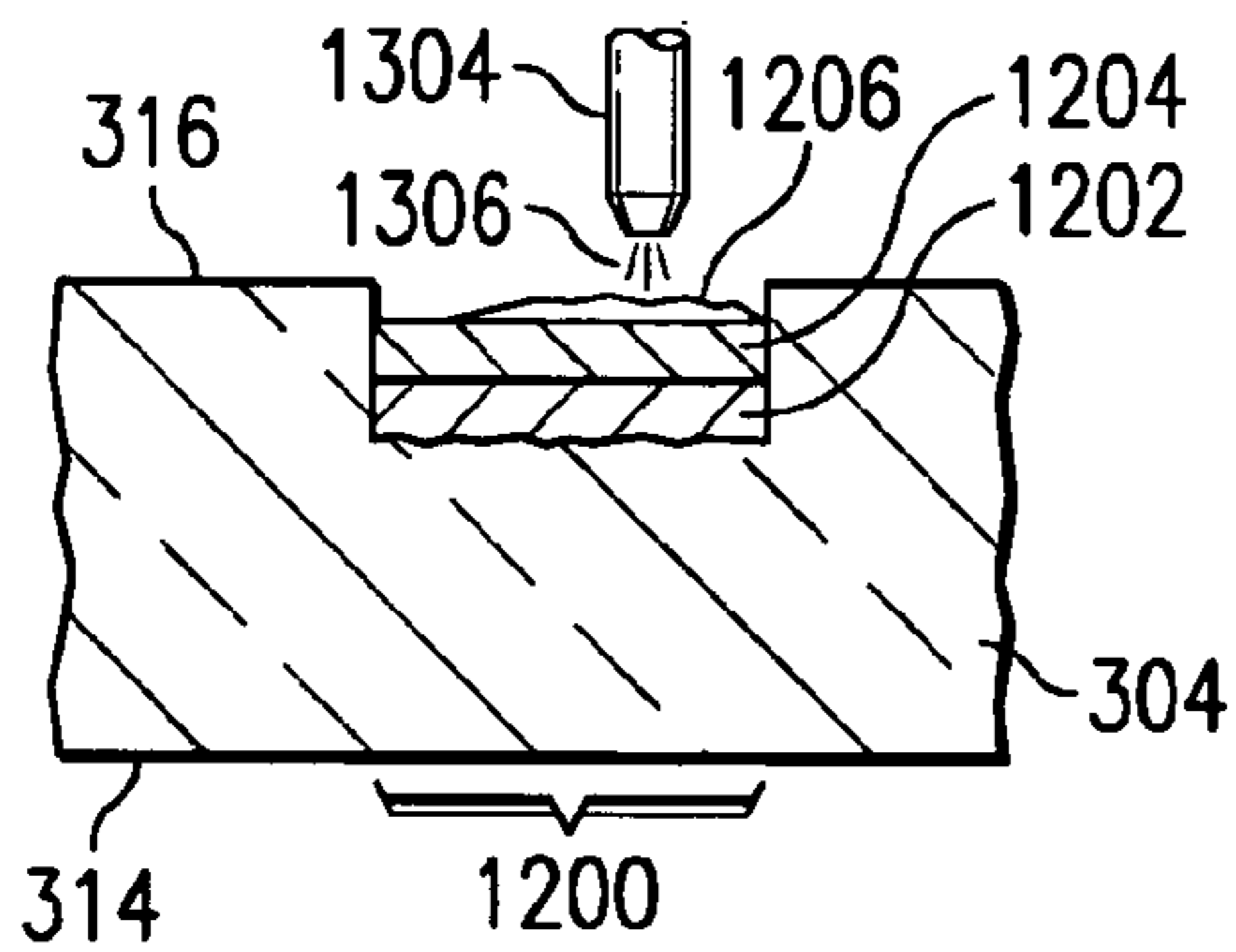

FIG. 13b

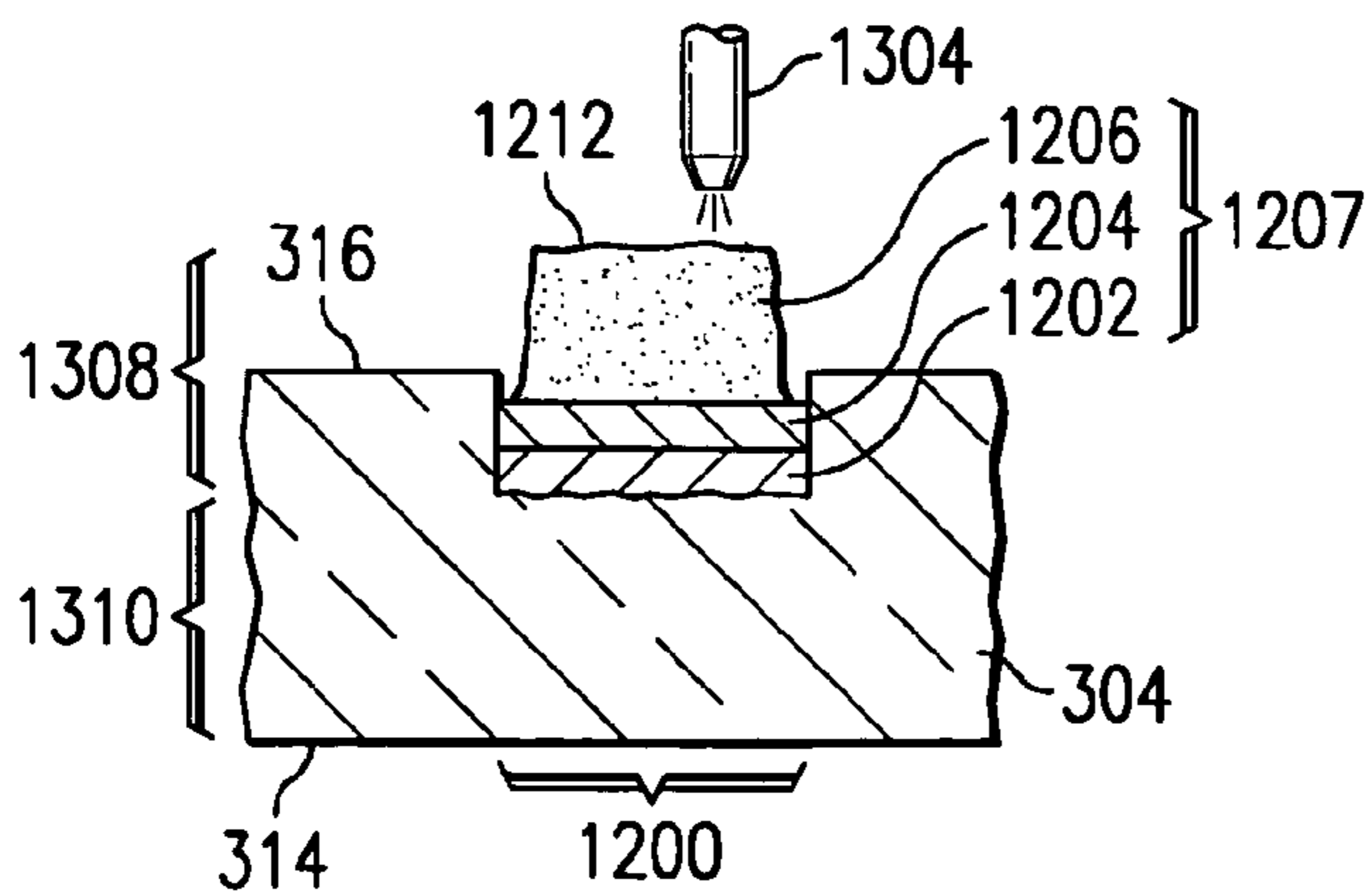

FIG. 13c

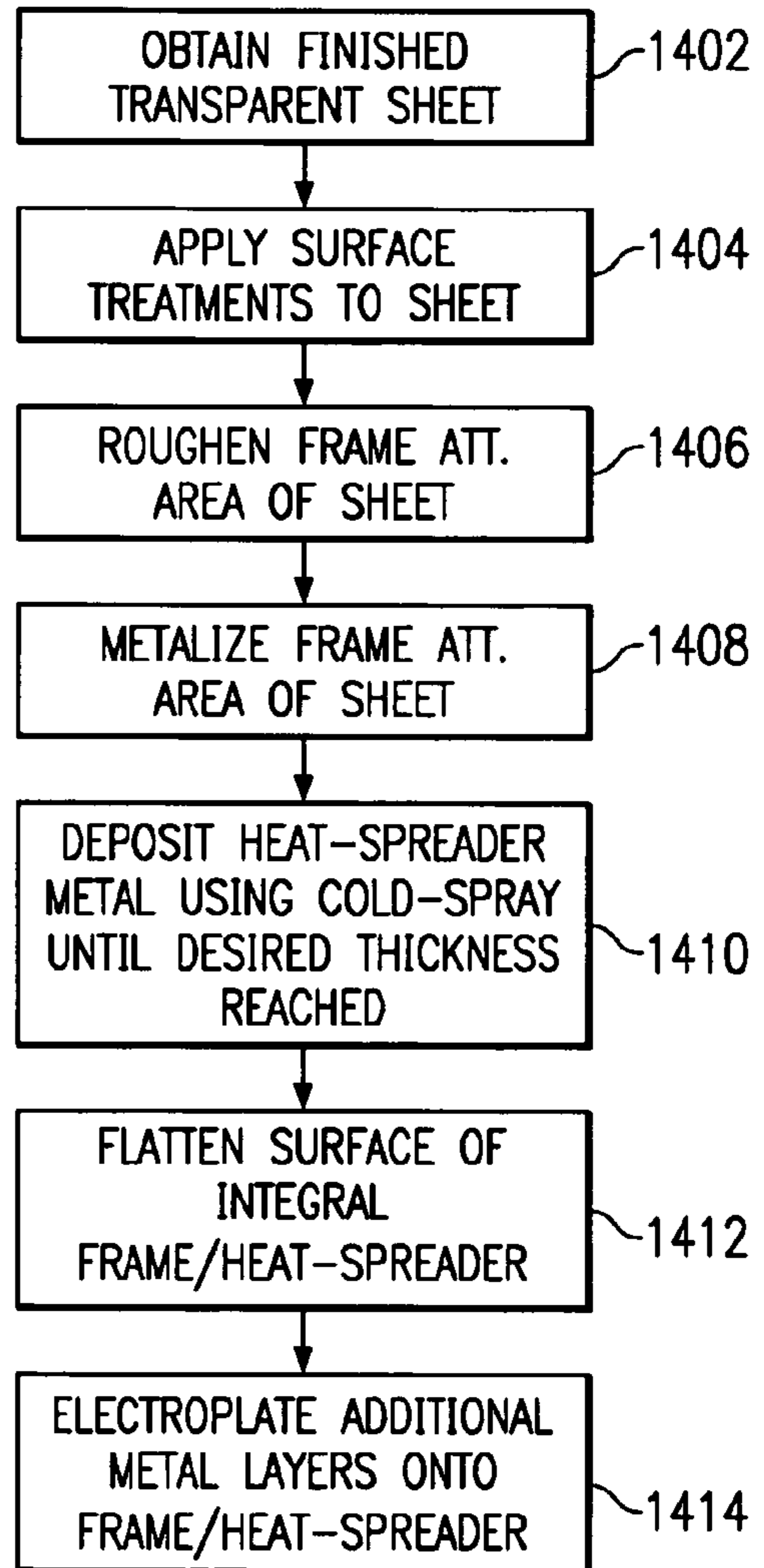
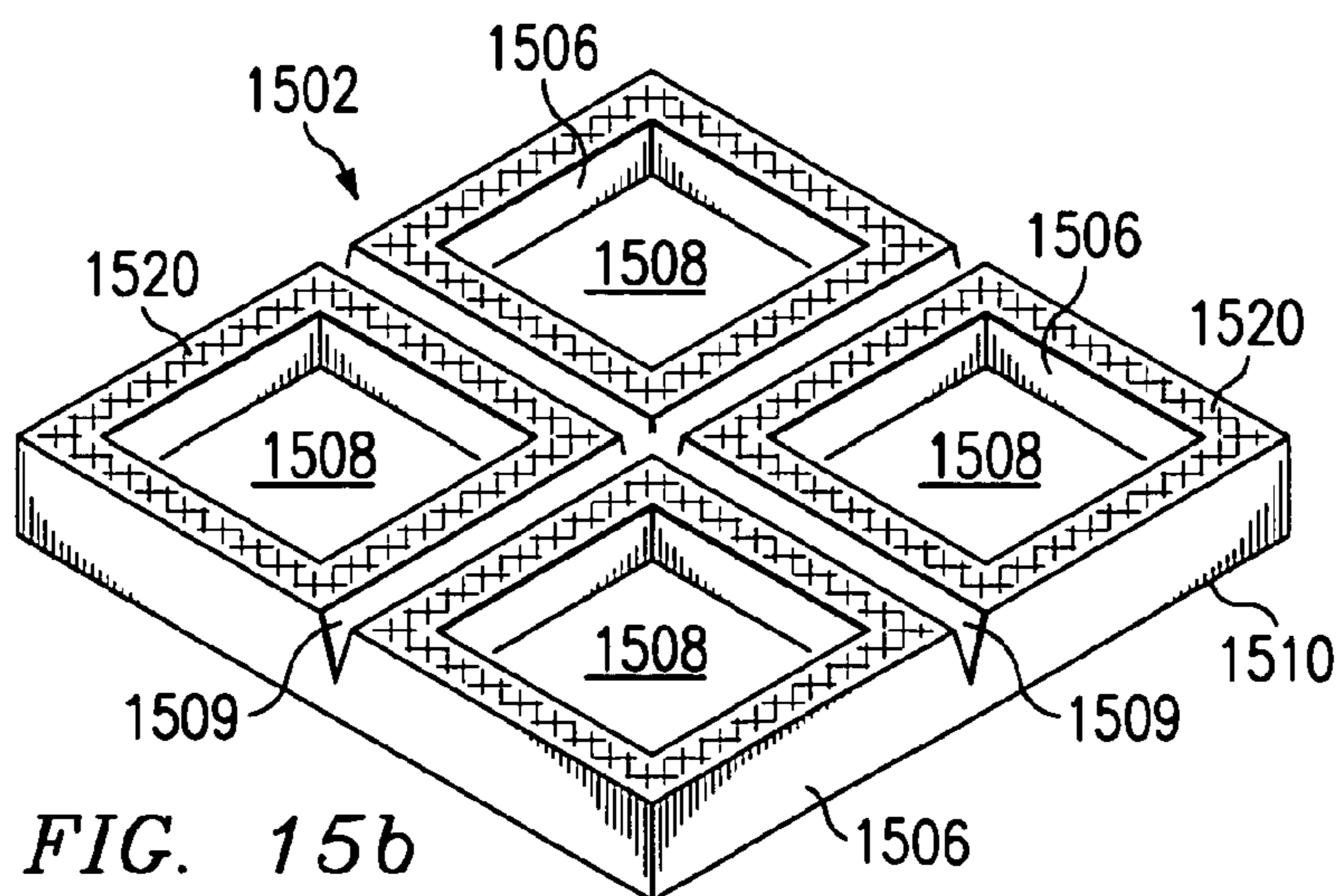
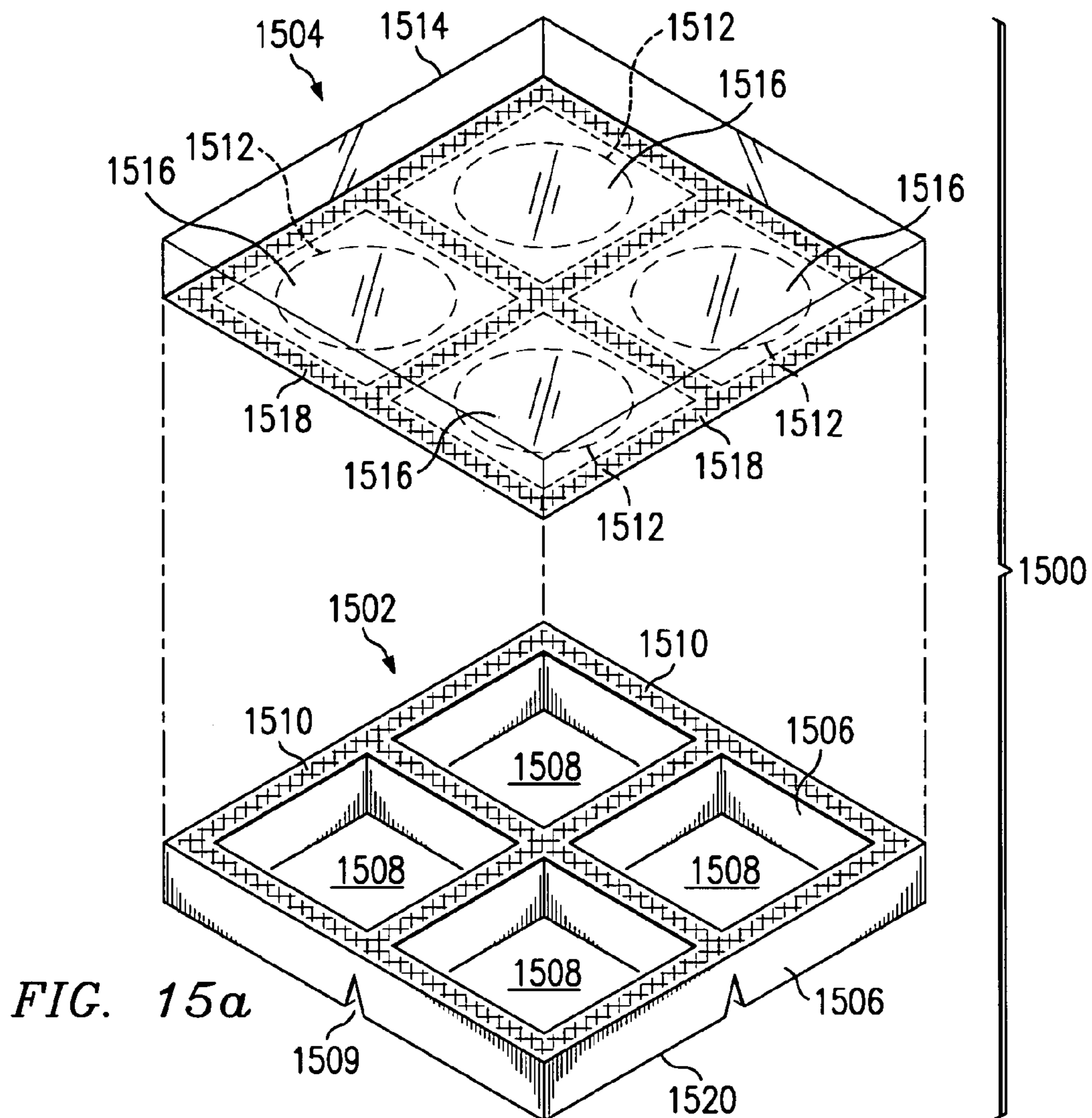

FIG. 14



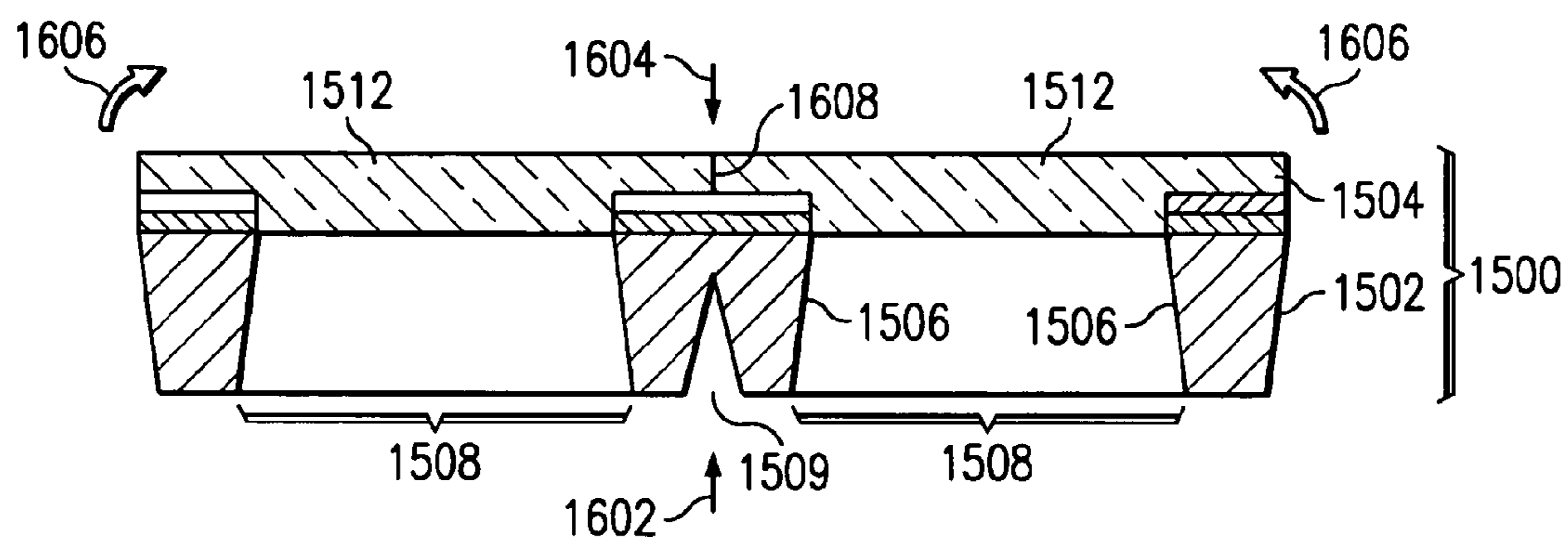
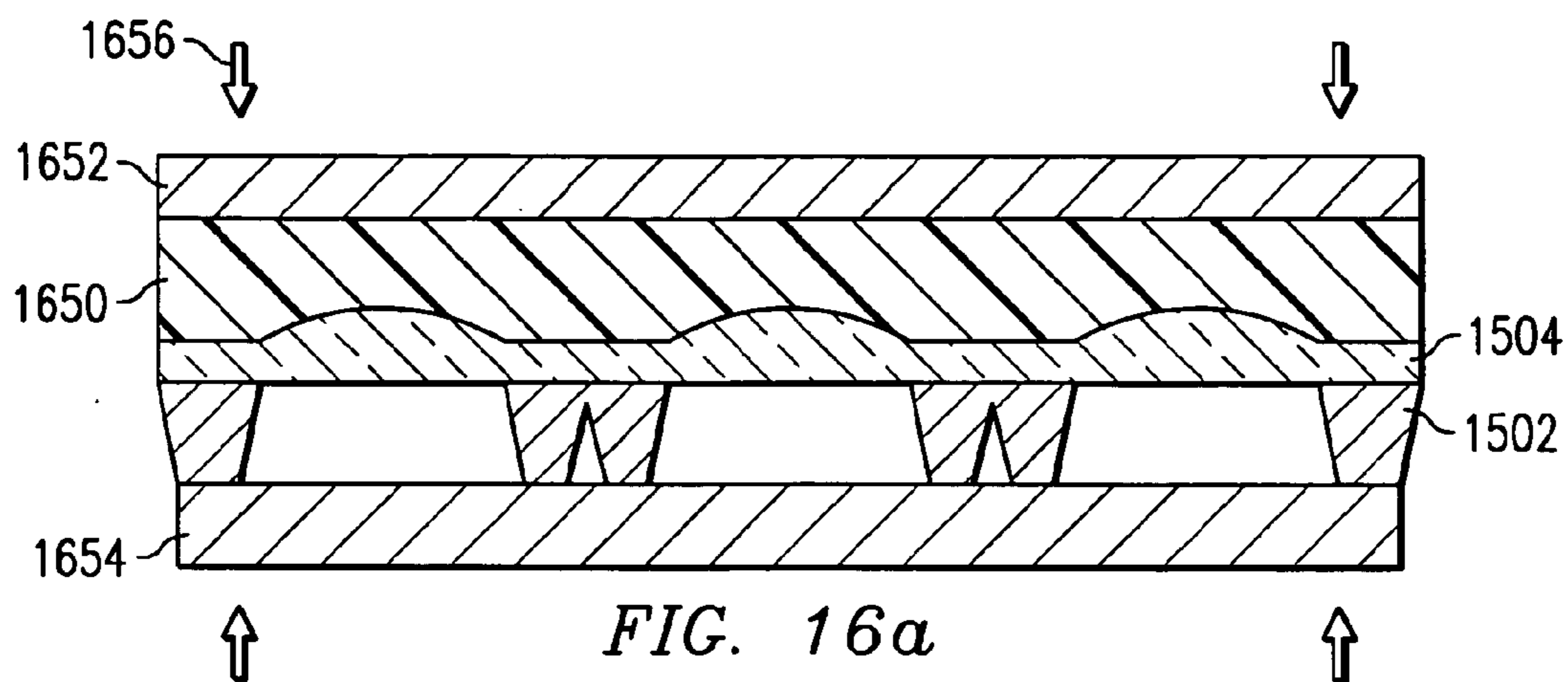

FIG. 16b

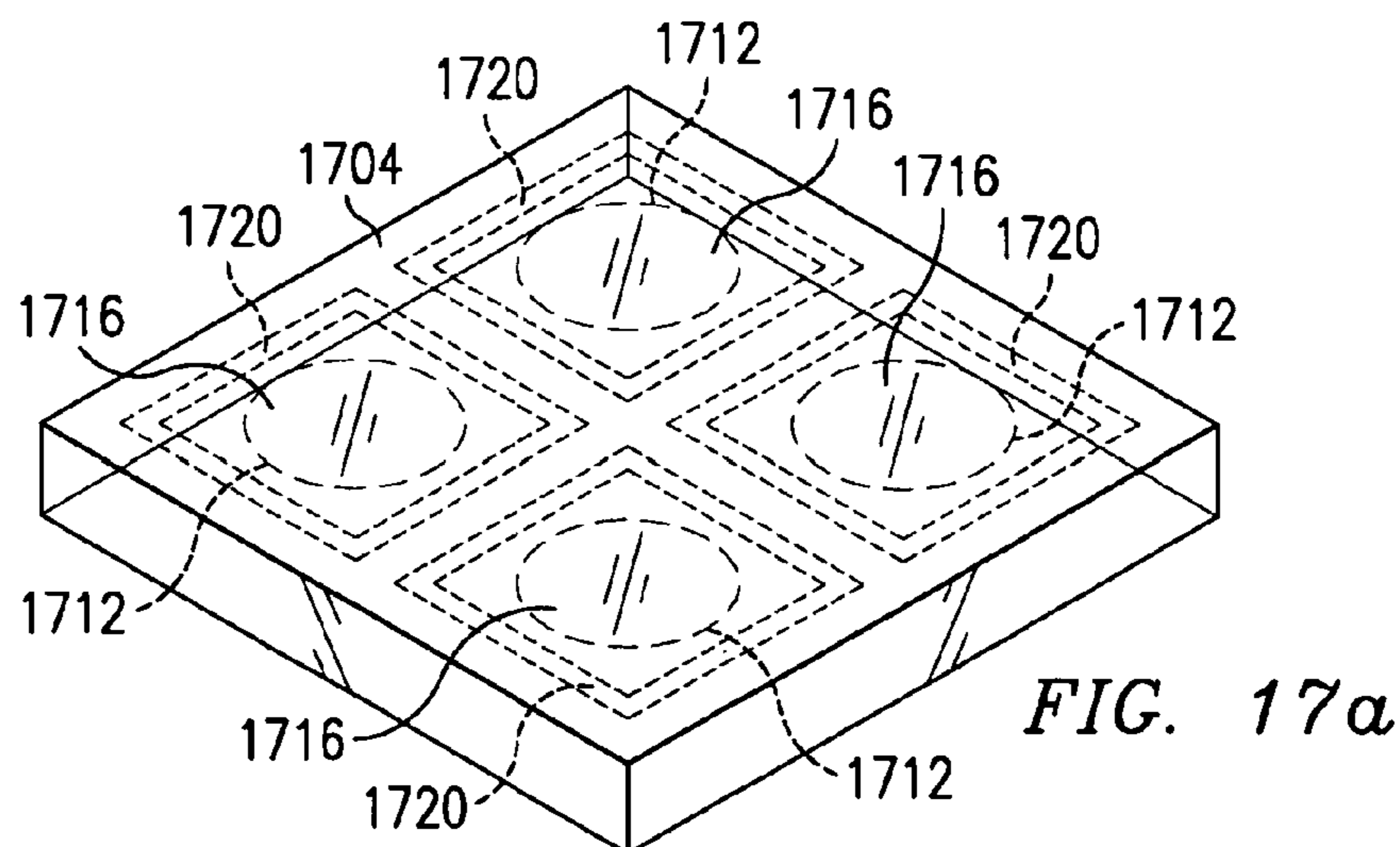
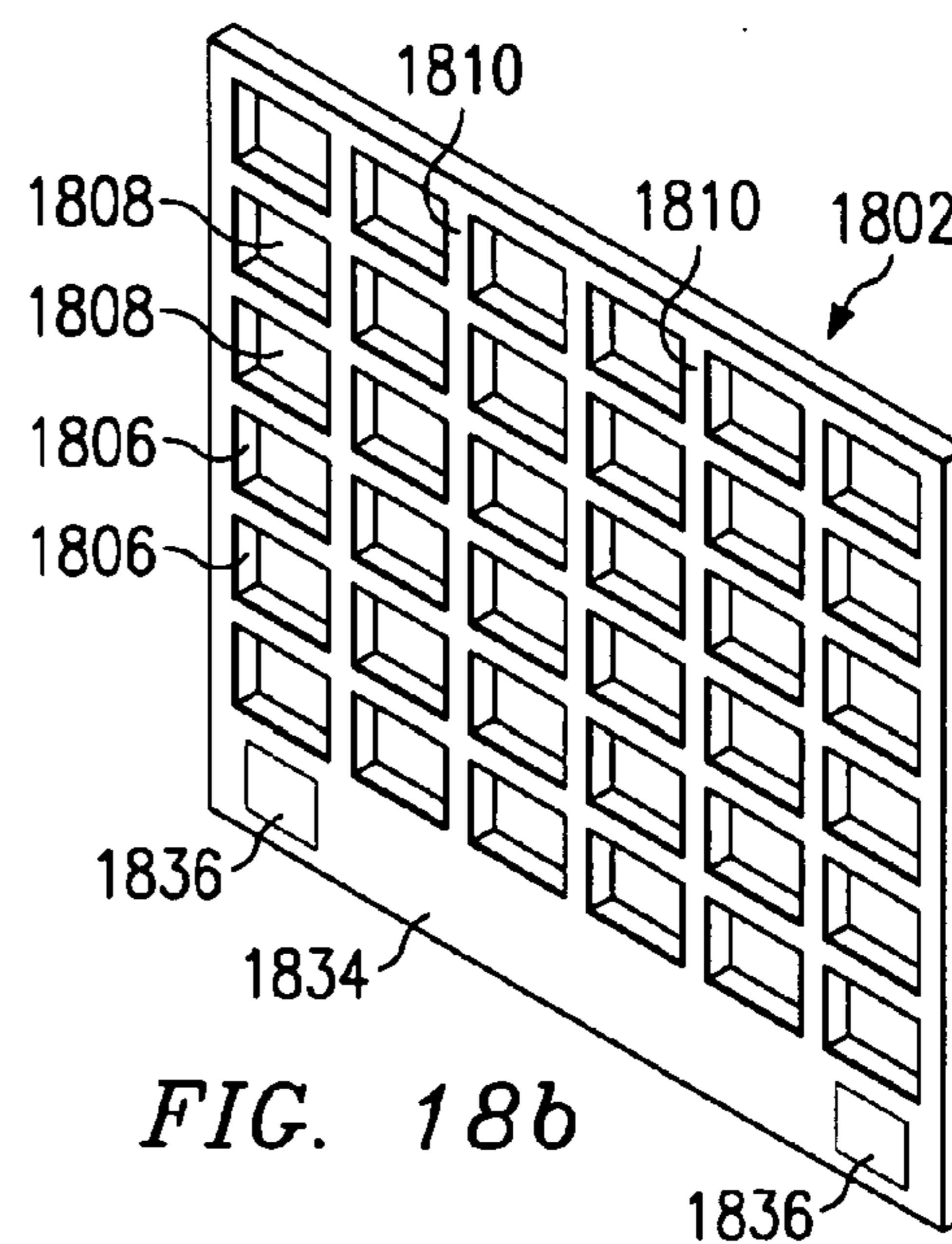
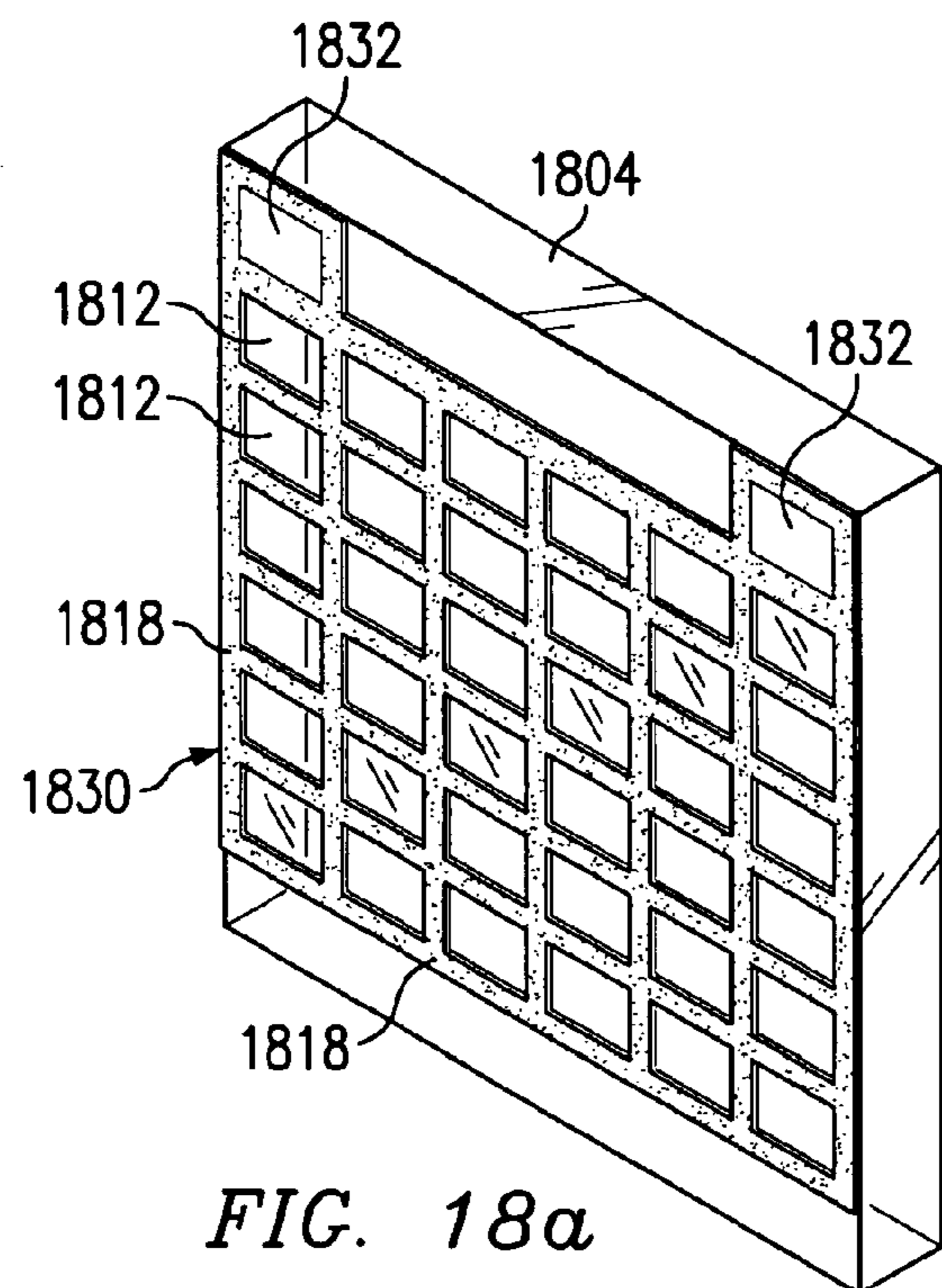
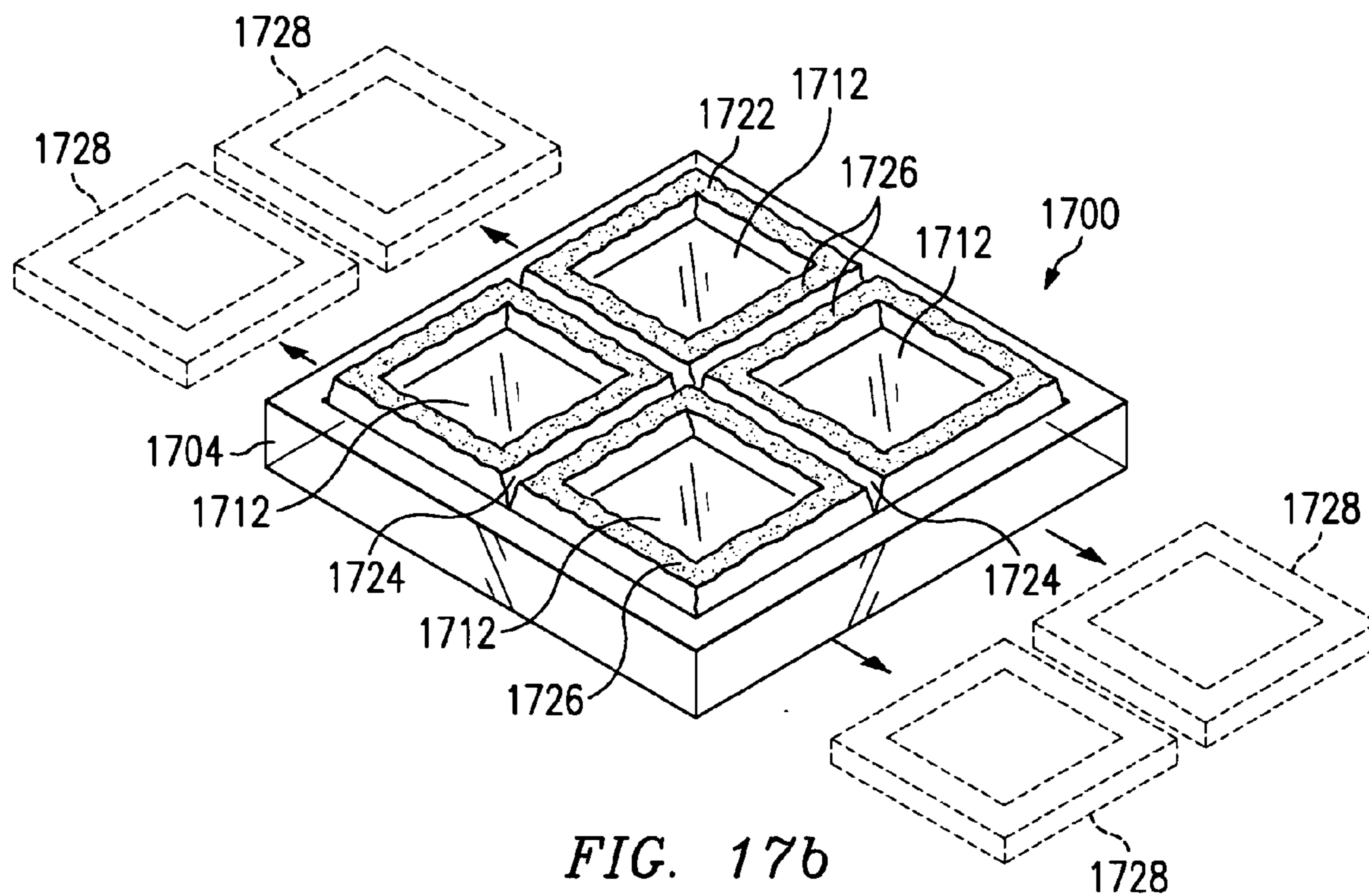

FIG. 17a



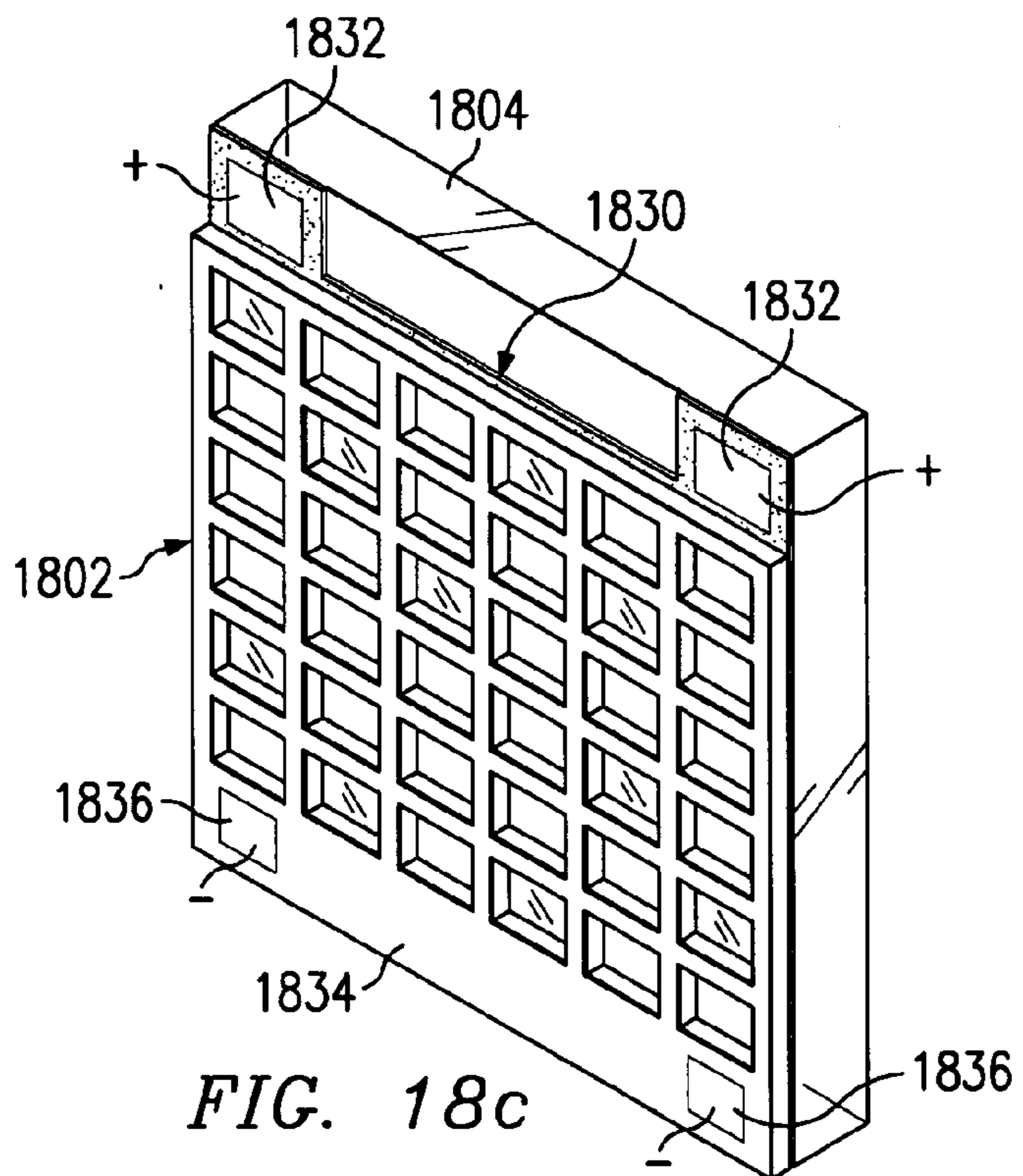

FIG. 18c

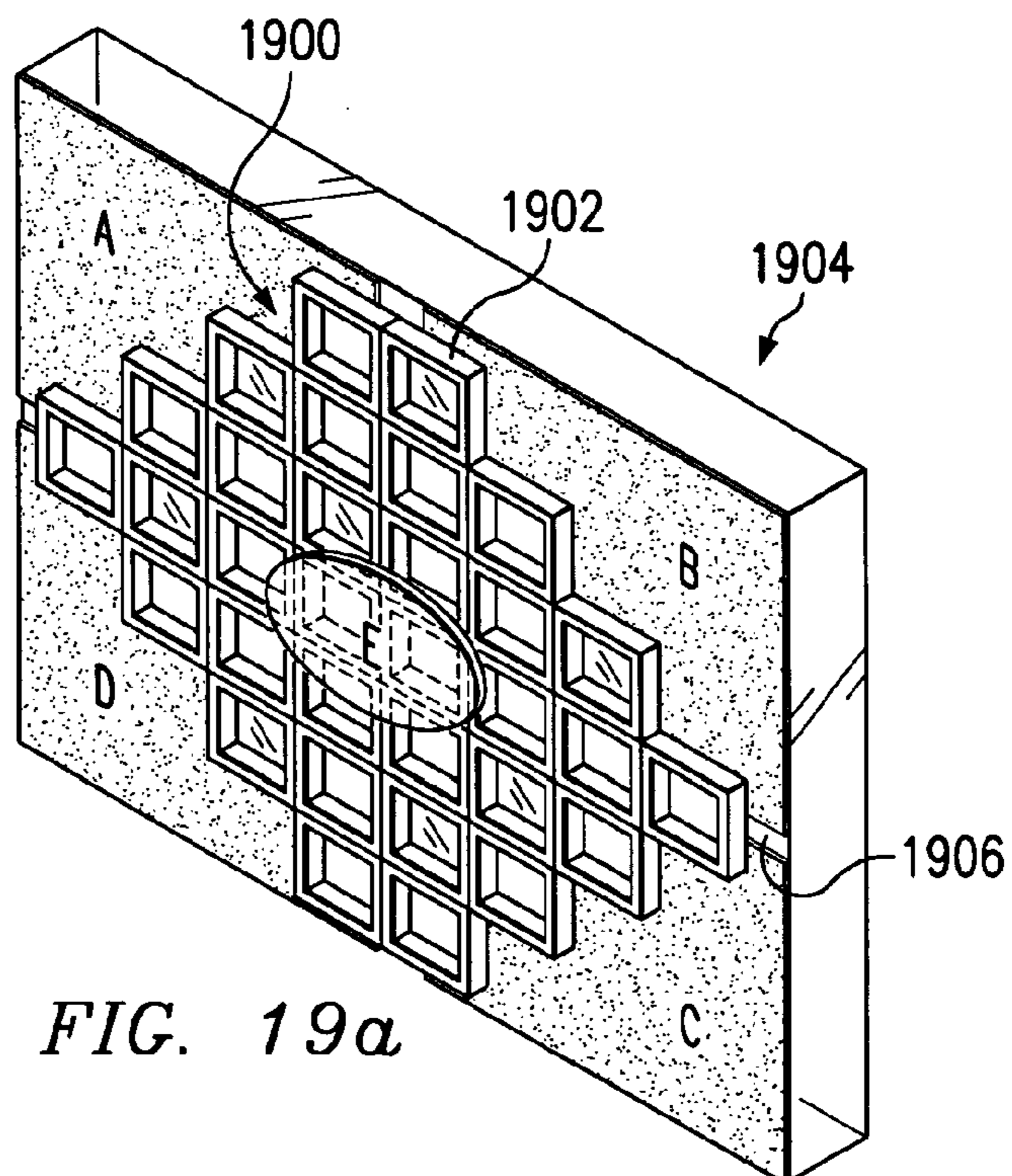

FIG. 19a

FIG. 19b

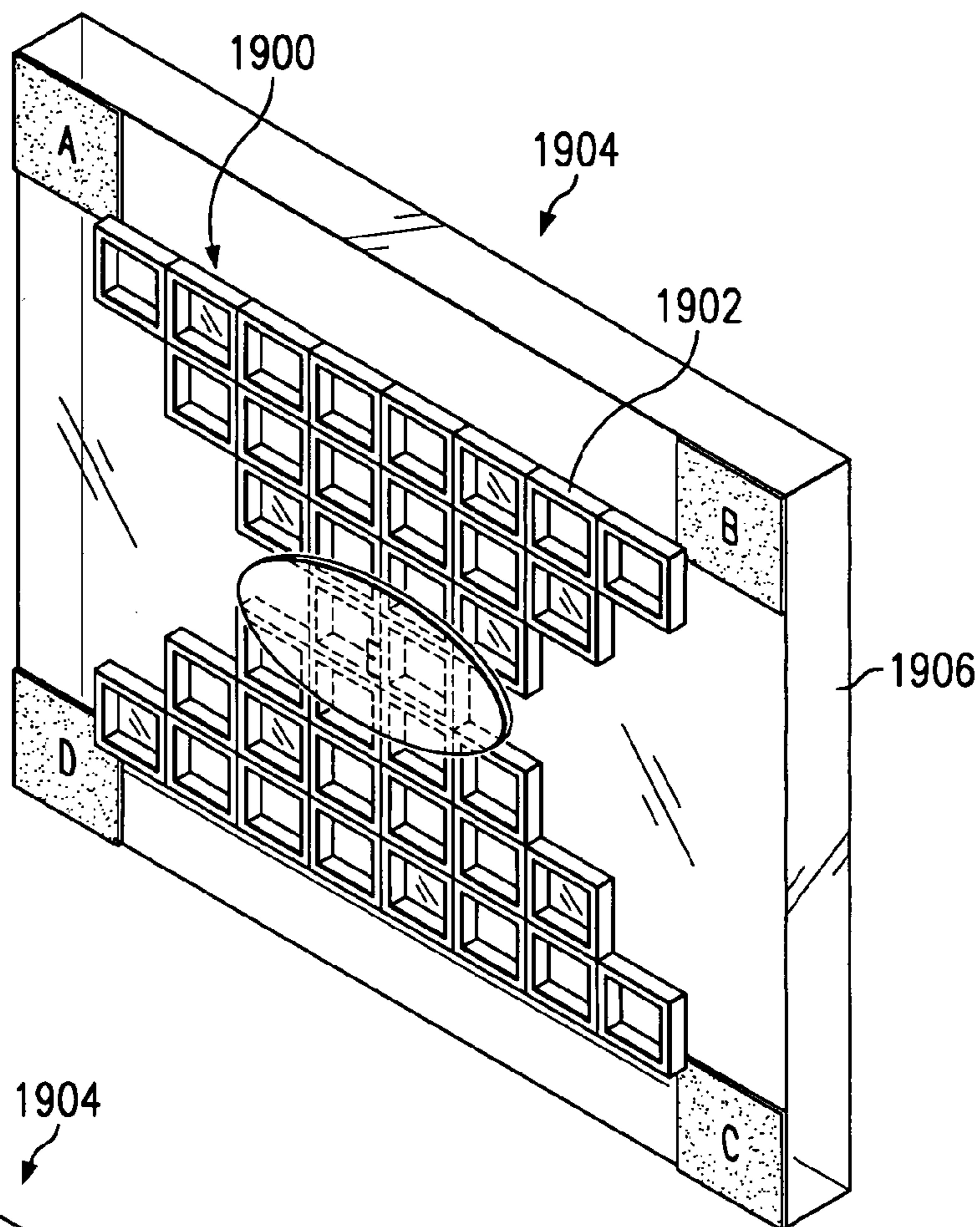

FIG. 19c

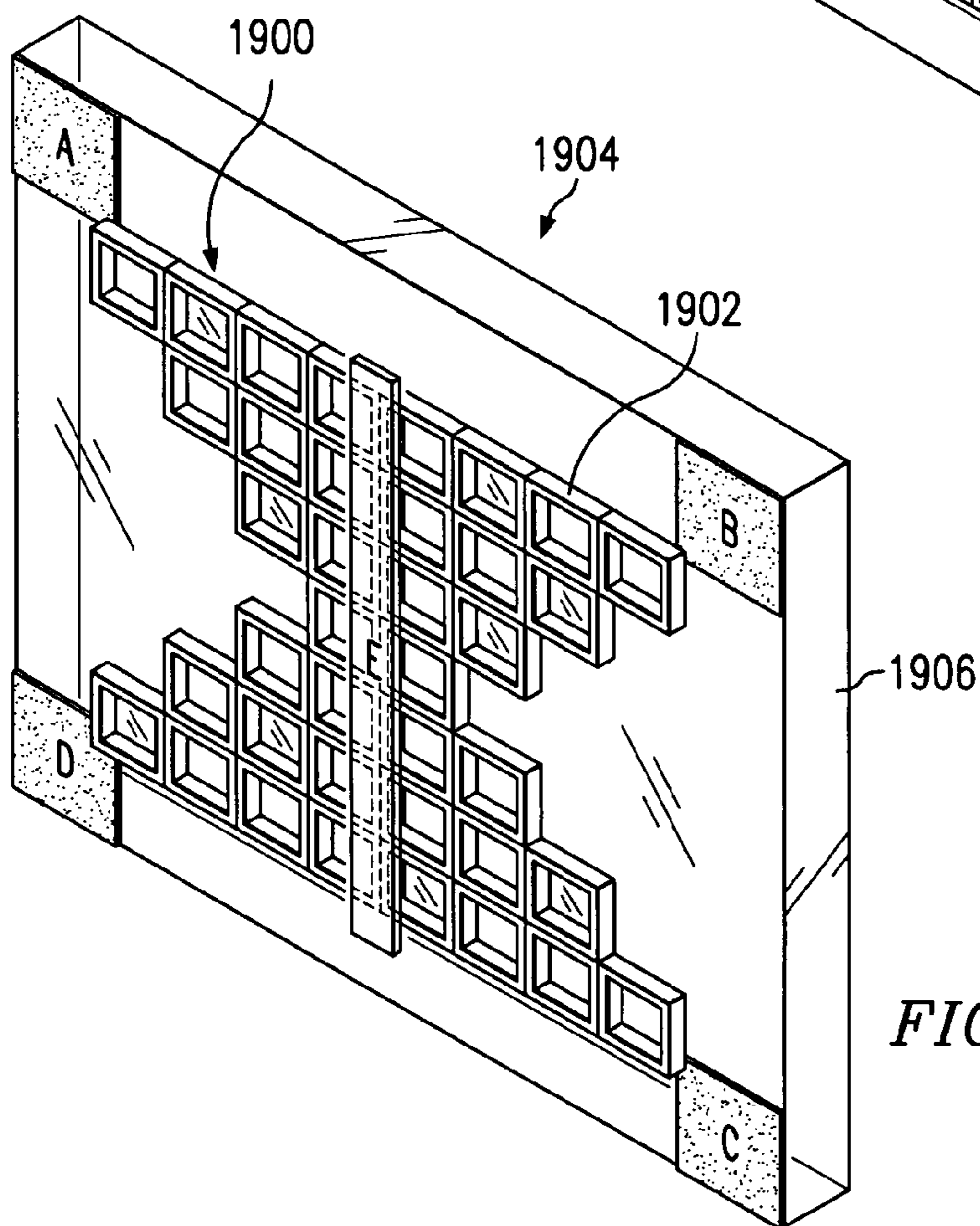

FIG. 19d

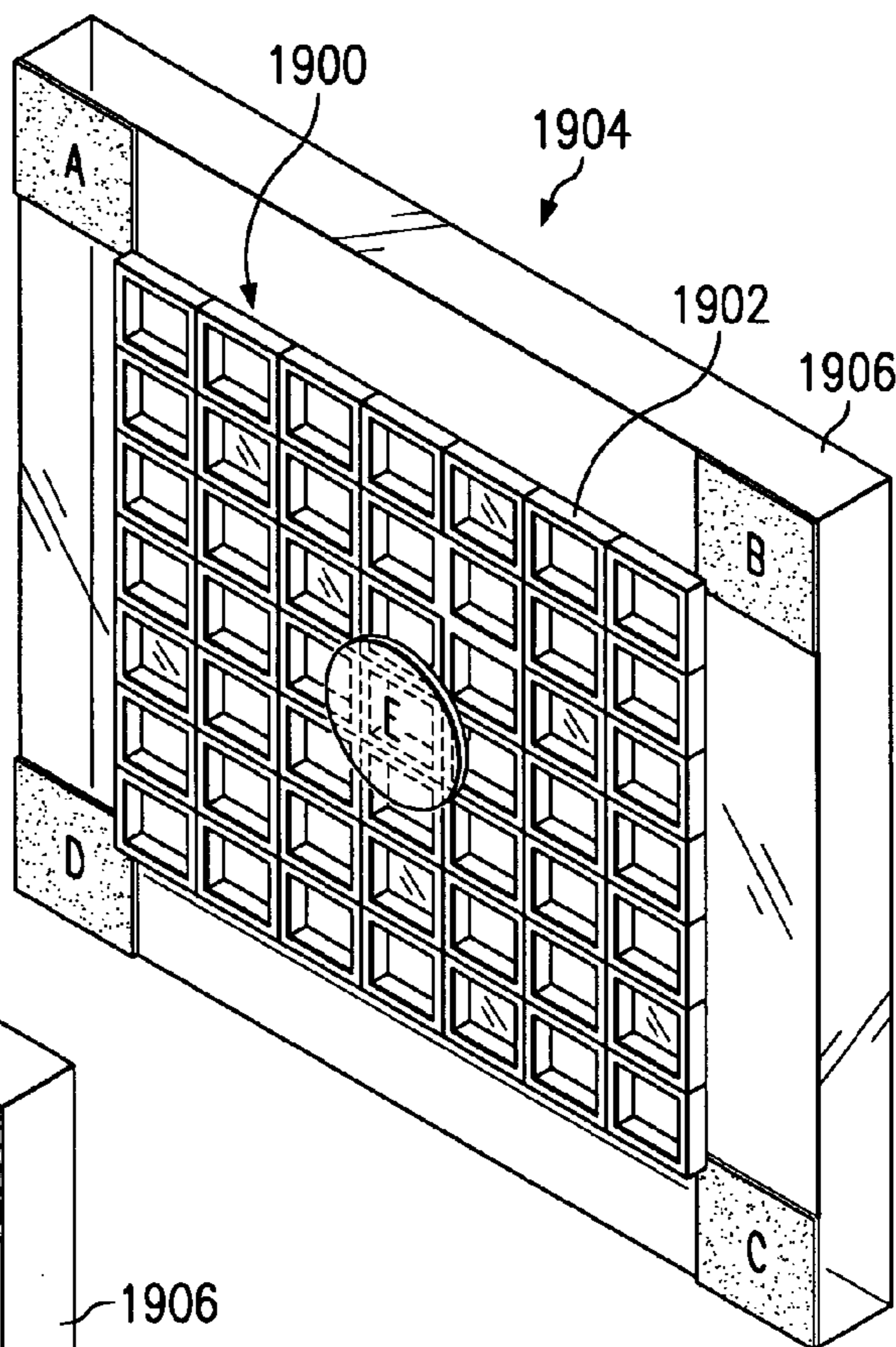

FIG. 19e

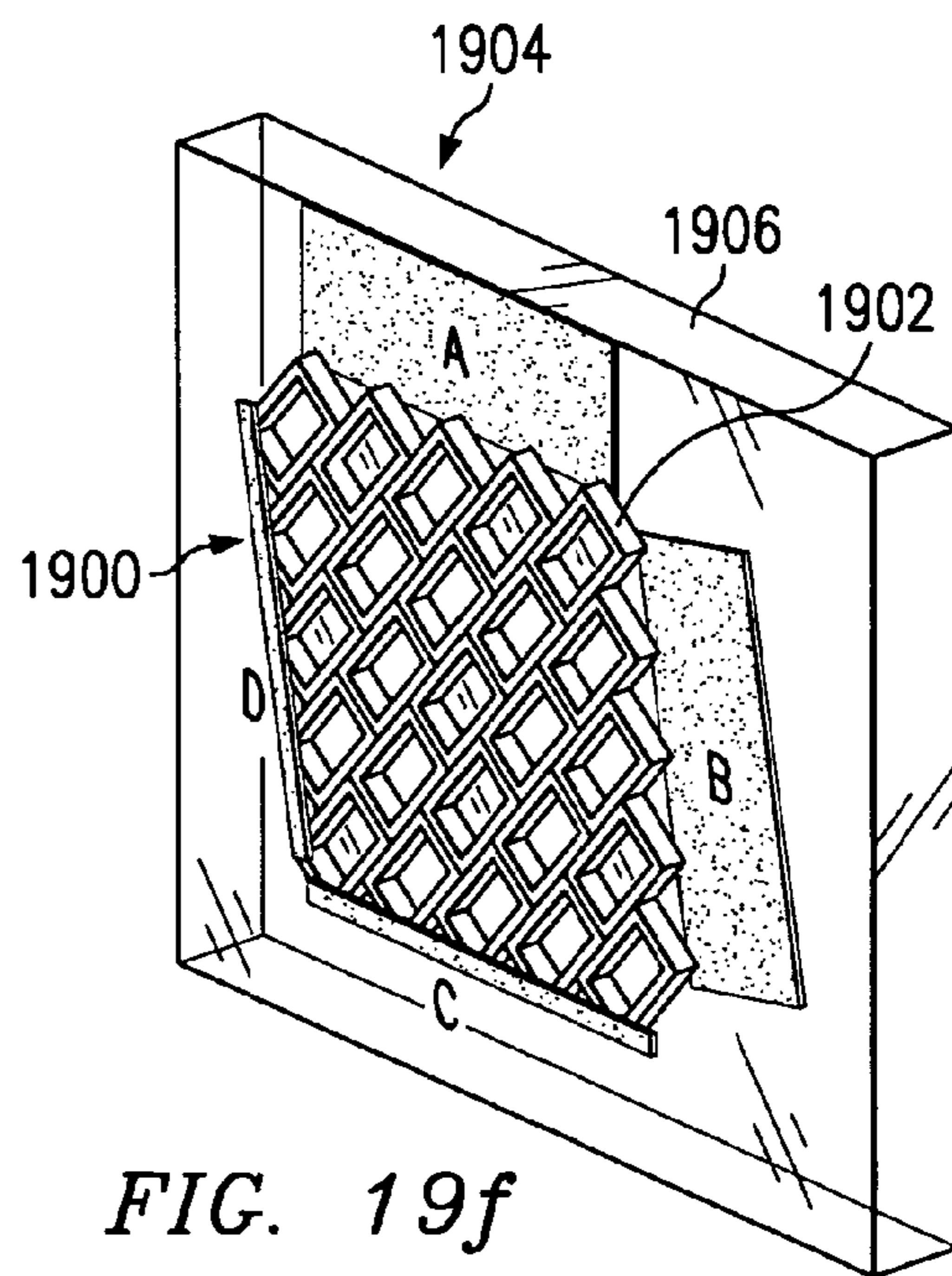
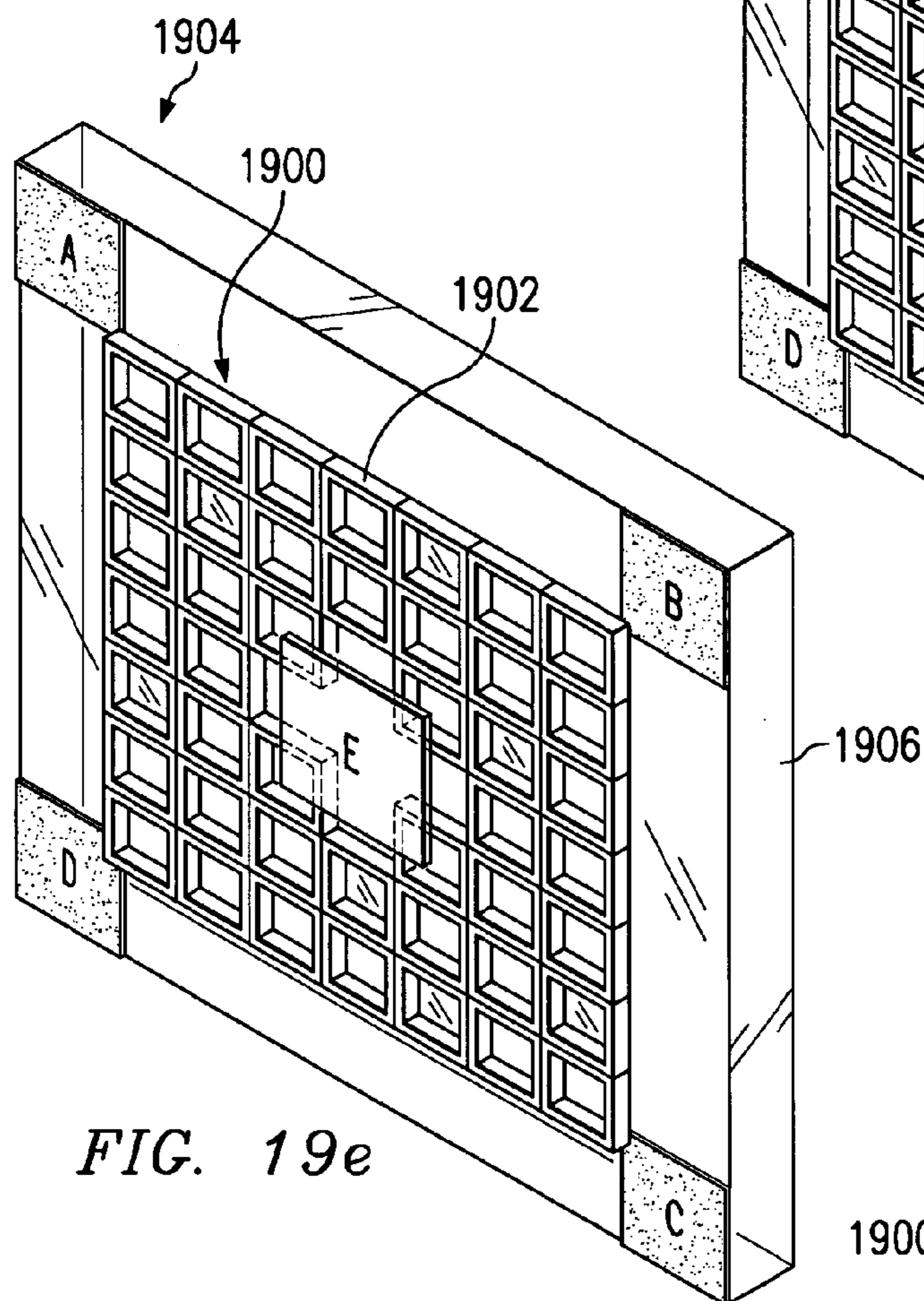

FIG. 19f

HERMETICALLY SEALED PACKAGE WITH WINDOW

CROSS-REFERENCE TO RELATED APPLICATIONS

[0001] This application is a Continuation of pending U.S. patent application Ser. No. 10/880,166, entitled “HERMETICALLY SEALED MICRO-DEVICE PACKAGE WITH WINDOW”, filed Jun. 29, 2004 (Atty. Dkt. No. STRK-26,824), which is a continuation of U.S. patent application Ser. No. 10/630,291, entitled “HERMETICALLY SEALED MICRO-DEVICE PACKAGE WITH WINDOW”, filed Jul. 30, 2003, now issued U.S. Pat. No. 6,759,590, issued on Jul. 6, 2004 (Atty. Dkt. No. STRK-26,422), which is a Continuation of U.S. patent application Ser. No. 10/104,315, entitled “HERMETICALLY SEALED MICRO-DEVICE PACKAGE WITH WINDOW”, filed Mar. 22, 2002, now issued U.S. Pat. No. 6,627,814, issued on Sep. 30, 2003 (Atty. Dkt. No. STRK-25,911).

TECHNICAL FIELD OF THE INVENTION

[0002] The current invention relates to packages for photonic devices, optical devices, micro-mechanical devices, micro-electromechanical systems (MEMS) devices or micro-optoelectromechanical systems (MOEMS) devices, and more particularly, to packages having a hermetically sealed chamber covered by a transparent window.

BACKGROUND OF THE INVENTION

[0003] Photonic, optical and micro-mechanical devices are typically packaged such that the active elements (i.e., the emitters, receivers, micro-mirrors, etc.) are disposed within a sealed chamber to protect them from handling and other environmental hazards. In many cases, it is preferred that the chamber be hermetically sealed to prevent the influx, egress or exchange of gasses between the chamber and the environment. Of course, a window must be provided to allow light or other electromagnetic energy of the desired wavelength to enter and/or leave the package. In some cases, the window will be visibly transparent, e.g. if visible light is involved, but in other cases the window may be visibly opaque while still being “optically” transparent to electromagnetic energy of the desired wavelengths. In many cases, the window is given certain optical properties to enhance the performance of the device. For example, a glass window may be ground and polished to achieve certain flatness specifications in order to avoid distorting the light passing therethrough. In other cases, anti-reflective or anti-refractive coatings may be applied to the window to improve light transmission therethrough.

[0004] Hermetically sealed micro-device packages with windows have heretofore been produced using cover assemblies with metal frames and glass window panes. To achieve the required hermetic seal, the glass window pane has heretofore been fused to its metallic frame by heating it in a furnace at a temperature exceeding the glass transition temperature, T_G (typically at or above 900° C.). However, because the fusing temperature is above T_G , the original surface finish of the glass pane is typically ruined, making it necessary to finish or re-finish (e.g., grinding and polishing) both surfaces of the window pane after fusing in order to obtain the necessary optical characteristics. This polishing of the window panes requires additional process steps during manufacture of the cover assemblies, which steps tend to be

relatively time and labor intensive, thus adding significantly to the cost of the cover assembly, and hence to the cost of the overall package. In addition, the need to polish both sides of the glass after fusing requires the glass to project both above and below the attached frame. This restricts the design options for the cover assembly with respect to glass thickness, dimensions, etc., which can also result in increased material costs.

[0005] Once a cover assembly with a hermetically sealed window is prepared, it is typically seam welded to the device base (i.e., substrate) in order to produce the finished hermetically sealed package. Seam welding uses a precisely applied AC current to produce localized temperatures of about 1,100° C. at the frame/base junction, thereby welding the metallic cover assembly to the package base and forming a hermetic seal. To prevent distortion of the glass windowpane or package, the metal frame of the cover assembly should be fabricated from Kovar alloy or another alloy having a CTE (i.e., coefficient of thermal expansion) which is similar to that of the transparent window material and to the CTE of the package base.

[0006] While the methods described above have heretofore produced useable window assemblies for hermetically sealed micro-device packages, the relatively high cost of these window assemblies is a significant obstacle to their widespread application. A need therefore exists, for package and component designs and assembly methods which reduce the labor costs associated with producing each package.

[0007] A need still further exists for package and component designs and assembly methods which will minimize the manufacturing cycle time required to produce a completed package.

[0008] A need still further exists for package and component designs and assembly methods which reduce the number of process steps required for the production of each package. It will be appreciated that reducing the number of process steps will reduce the overhead/floor space required in the production facility, the amount of capital equipment necessary for manufacturing, and handling costs associated with transferring the work pieces between various steps in the process. A reduction in the cost of labor may also result. Such reductions would, of course, further reduce the cost of producing these hermetic packages.

[0009] A need still further exists for package and component designs and assembly methods which will reduce the overall materials costs associated with each package, either by reducing the initial material cost, by reducing the amount of wastage or loss during production, or both.

SUMMARY OF THE INVENTION

[0010] The present invention disclosed and claimed herein comprises, in one aspect thereof a method for manufacturing a cover assembly including a transparent window portion and a frame of gas-impervious material that can be hermetically attached to a micro-device package base to form a hermetically sealed micro-device package. First, a frame of gas-impervious material is provided, the frame having a continuous sidewall defining a frame aperture there through. The sidewall includes a frame seal-ring area circumscribing the frame aperture. A sheet of a transparent material is also provided, the sheet having a window portion defined thereupon. The window portion has finished top and bottom surfaces. A sheet seal-ring area is prepared on the sheet, the sheet seal-ring area circumscribing the window portion. The frame is

positioned against the sheet such that at least a portion of the frame seal-ring area and at least a portion of the sheet seal-ring area contact one another along a continuous junction region that circumscribes the window portion. The frame is pressed against the sheet with sufficient force to produce a predetermined contact pressure between the frame seal-ring area and the sheet seal-ring area along the junction region. The junction region is heated to produce a predetermined temperature all along the junction region. The predetermined contact pressure and the predetermined temperature are maintained until a diffusion bond is formed between the frame and sheet all along the junction region.

[0011] The present invention disclosed and claimed herein comprises, in another aspect thereof, a cover assembly including a transparent window portion and a frame that can be joined to a micro-device package base to form a hermetically sealed micro-device package.

[0012] The present invention disclosed and claimed herein comprises, in yet another aspect thereof, a micro-device module including a package base, micro-device mounted on the package base, and a cover assembly having a transparent window portion and a frame, the cover assembly being hermetically joined to the package base to hermetically seal the micro-device within a cavity formed there between.

BRIEF DESCRIPTION OF THE DRAWINGS

[0013] FIG. 1 is a perspective view of a hermetically sealed micro-device package;

[0014] FIG. 2 is a cross-sectional view of the micro-device package of FIG. 1;

[0015] FIG. 3 is an exploded view of a cover assembly manufactured in accordance with one embodiment of the current invention;

[0016] FIGS. 4a and 4b show transparent sheets having contoured sides, specifically:

[0017] FIG. 4a showing a sheet having both sides contoured;

[0018] FIG. 4b showing a sheet having one side contoured;

[0019] FIG. 5 shows an enlarged view of the sheet seal-ring area prior to metalization;

[0020] FIG. 6 shows an enlarged view of the sheet seal-ring area after metalization;

[0021] FIG. 7 shows a cross-sectional view through a pre-fabricated frame;

[0022] FIG. 8 illustrates placing the frame against the metallized sheet prior to bonding;

[0023] FIG. 9 is a block diagram of a process for manufacturing cover assemblies using prefabricated frames in accordance with one embodiment;

[0024] FIG. 10 is an exploded view of a cover assembly manufactured using a solder preform;

[0025] FIG. 11 is a partial perspective view of another embodiment utilizing solder applied by inkjet;

[0026] FIGS. 12a-c and FIGS. 13a-c illustrate a process of manufacturing cover assemblies in accordance with yet another embodiment of the invention, specifically:

[0027] FIG. 12a shows the initial transparent sheet;

[0028] FIG. 12b shows the transparent sheet after initial metallization;

[0029] FIG. 12c shows the transparent sheet after deposition of the integral frame/heat spreader;

[0030] FIG. 13a shows a partial cross-section of the sheet of FIG. 12a;

[0031] FIG. 13b shows a partial cross-section of the sheet of FIG. 12b;

[0032] FIG. 13c shows a partial cross-section of the sheet of FIG. 12c;

[0033] FIG. 14 is a block diagram of a process for manufacturing cover assemblies using cold gas dynamic spray technology in accordance with another embodiment;

[0034] FIGS. 15a-15b illustrate a multi-unit assembly manufactured in accordance with another embodiment; specifically:

[0035] FIG. 15a illustrates an exploded view of a the multi-unit assembly;

[0036] FIG. 15b is bottom view of the frame of FIG. 15a;

[0037] FIG. 16a illustrates compliant tooling formed in accordance with another embodiment;

[0038] FIG. 16b is a side view of a multi-unit assembly illustrating the method of separation;

[0039] FIGS. 17a and 17b illustrate the manufacture of multiple cover assemblies in accordance with yet another embodiment, specifically:

[0040] FIG. 17a shows the transparent sheet in its original state;

[0041] FIG. 17b illustrates the sheet after deposition of the multi-aperture frame/heat spreader;

[0042] FIGS. 18a-18c illustrate an assembly configuration suitable for use with electrical resistance heating; specifically:

[0043] FIG. 18a illustrates the configuration of the sheet;

[0044] FIG. 18b illustrates the configuration of the frame;

[0045] FIG. 18c illustrates the joined sheet and frame; and

[0046] FIGS. 19a-19f illustrate multi-unit assembly configurations suitable for heating with electrical resistance heating.

DETAILED DESCRIPTION OF THE INVENTION AND BEST MODE

[0047] Referring now to FIGS. 1 and 2, there is illustrated a typical hermetically sealed micro-device package for housing photonic devices, optical devices (i.e., including reflective, refractive and diffractive type devices), micro-optoelectromechanical systems (i.e., MOEMS) devices and micro-electromechanical systems (i.e., MEMS) devices. The package 102 comprises a base or substrate 104 which is hermetically sealed to a cover assembly 106 comprising a frame 108 and a transparent window 110. A micro-device 112 mounted on the base 104 is encapsulated within a cavity 114 when the cover assembly 106 is joined to the base 104. One or more electrical leads 116 may pass through the base 104 to carry power, ground, and signals to and from the micro-device 112 inside the package 102. It will be appreciated that the electrical leads 116 must also be hermetically sealed to maintain the integrity of the package 102. The window 110 is formed of an optically or electro-magnetically transparent material. For purposes of this application, the term "transparent" refers to materials which allow the transmission of electromagnetic radiation having predetermined wavelengths, including, but not limited to, visible light, infrared light, ultraviolet light, microwaves, radio waves, or x-rays. The frame 108 is formed from a material, typically a metal alloy, which preferably has a CTE close to that of both the window 110 and the package base 104.

[0048] Referring now to FIG. 3, there is illustrated an exploded view of a cover assembly manufactured in accordance with one embodiment of the current invention. The

cover assembly **300** includes a frame **302** and a sheet **304** of a transparent material. The frame **302** has a continuous sidewall **306** which defines a frame aperture **308** passing there-through. The frame sidewall **306** includes a frame seal-ring area **310** (denoted by crosshatching) circumscribing the frame aperture **308**. Since the frame **302** will eventually be welded to the package base **104**, it is usually formed of a weldable metal or alloy, preferably one having a CTE very close to that of the micro-device package base **104**. In some embodiments, however, the cover assembly frame **304** may be formed of a non-metallic material such as ceramic or alumina. Regardless of whether the frame **302** is formed of a metallic or non-metallic material, the surface of the frame seal-ring area **310** must be metallic (e.g., metal plated if not solid metal) to facilitate the hermetic sealing of the sheet **304** to the frame. In a preferred embodiment, the frame is primarily formed of an alloy having a nominal chemical composition of 54% iron (Fe), 29% nickel (Ni) and 17% cobalt (Co). Such alloys are also known by the designation ASTM F-15 alloy and by the trade name Kovar Alloy. As used in this application, the term "Kovar Alloy" will be understood to mean the alloy having the chemical composition just described. In embodiments where a Kovar Alloy frame **302** is used, it is preferred that the surface of the frame seal-ring area **310** have a surface layer of gold (Au) overlying a layer of nickel (Ni). The frame **302** also includes a base seal area **320** which is adapted for eventual joining, typically by welding, to the package base **104**. The base seal area **320** frequently includes a layer of nickel overlaid by a layer of gold to facilitate seam welding to the package base. Although the gold over nickel surface layers are only required along the base seal-ring area **320**, it will be appreciated that in many cases, for example, where solution bath plating is used to apply the surface materials, the gold over nickel layers may be applied to the entire surface of the frame **302**. The sheet **304** can be any type of transparent material, for example, soft glass (e.g., soda-lime glass), hard glass (e.g. borosilicate glass), crystalline materials such as quartz and sapphire, or polymeric materials such as polycarbonate plastic. As previously discussed, it is preferred that the material of the sheet **304** have a CTE that is similar to that of the frame **304** and of the package base **104** to which the cover assembly will eventually be attached. For many semiconductor photonic, MEMS or MOEMS applications, a borosilicate glass is well suited for the material of the sheet **304**. Examples of suitable glasses include Corning 7052, 7050, 7055, 7056, 7058, 7062, Kimble (Owens Corning) EN-1, and Kimble K650 and K704. Other suitable glasses include Abrisa soda-lime glass, Schott 8245 and Ohara Corporation S-LAM60.

[0049] The sheet **304** has a window portion **312** defined thereupon, i.e., this is the portion of the sheet **302** which must remain transparent to allow for the proper functioning of the encapsulated, i.e., packaged, micro-device **112**. The window portion **312** of the sheet has top and bottom surfaces **314** and **316**, respectively, that are optically finished in the preferred embodiment. The sheet **304** is preferably obtained with the top and bottom surfaces **314** and **316** of the window portion **312** in ready to use form, however, if necessary the material may be ground and polished or otherwise shaped to the desired surface contour and finish as a preliminary step of the manufacturing process. While in many cases the window portion **312** will have top and bottom surfaces of **314** and **316** that are optically flat and parallel to one another, it will be appreciated that in other embodiments at least one of the

finished surfaces of the window portion will be contoured. A sheet seal-ring area **318** (denoted with cross-hatching) circumscribes the window portion **312** of the sheet **304**, and provides a suitable surface for joining to the front seal-ring area **310**.

[0050] Referring now to FIGS. **4a** and **4b**, there are illustrated transparent sheets having contoured sides. In FIG. **4a**, transparent sheet **304'** has both a curved top side **314'** and a curved bottom side **316'** producing a window portion **312** having a curved contour with a constant thickness. In FIG. **4b**, sheet **304''** has a top side **314''** which is curved and a bottom side **316''** which is flat, thereby resulting in a window portion **312** having a plano-convex lens arrangement. It will be appreciated that in similar fashion (not illustrated) the finished surfaces **314** and **316** of the window portion **312** can have the configuration of a refractive lens including a plano-convex lens as previously illustrated, a double convex lens, a plano-concave lens or a double concave lens. Other surface contours may give the finished surfaces of the window portion **312** the configuration of a Fresnel lens or of a diffraction grating, i.e., "a diffractive lens."

[0051] In many applications, it is desirable that window portion **312** of the sheet **304** have enhanced optical or physical properties. To achieve these properties, surface treatments or coatings may be applied to the sheet **304** prior to or during the assembly process. For example, the sheet **304** may be treated with siliconoxynitride (SiOn) to provide a harder surface on the window material. Whether or not treated with SiOn, the sheet **304** may be coated with a scratch resistant/abrasion resistant material such as amorphous diamond-like carbon (DLC) such as that sold by Diamonex, Inc., under the name Diamond Shield®. Other coatings which may be applied in addition to, or instead of, the SiOn or diamond-like carbon include, but are not limited to, optical coatings, anti-reflective coatings, refractive coatings, achromatic coatings, optical filters, electromagnetic interference (EMI) and radio frequency (RF) filters of the type known for use on lenses, windows and other optical elements. It will be appreciated that the optical coatings and/or surface treatments can be applied either on the top surface **314** or the bottom surface **316**, or in combination on both surfaces, of the window portion **312**. It will be further appreciated, that the optical coatings and treatments just described are not illustrated in the figures due to their transparent nature.

[0052] In some applications, a visible aperture is formed around the window portion **312** of the sheet **304** by first depositing a layer of non-transparent material, e.g., chromium (Cr), over the entire surface of the sheet and then etching the non-transparent material from the desired aperture area. This procedure provides a sharply defined border to the window portion **312** which is desirable in some applications. This operation may be performed prior to or after the application of other treatments depending on the compatibility and processing economics.

[0053] The next step of the process of manufacturing the cover assembly **300** is to prepare the sheet seal-ring area **318** for metalization. The sheet seal-ring area **318** circumscribes the window portion **312** of the sheet **304**, and for single aperture covers is typically disposed about the perimeter of the bottom surface **316**. It will be appreciated, however, that in some embodiments the sheet seal-ring area **318** can be located in the interior portion of a sheet, for example where the sheet will be diced to form multiple cover assemblies (i.e., as described later herein). The sheet seal-ring area **318** gen-

erally has a configuration which closely matches the configuration of the frame seal-ring area **310** to which it will eventually be joined. At a minimum preparing the sheet seal-ring area **318** involves a thorough cleaning to remove any greases, oils or other contaminants from the surface. More commonly, preparing the sheet seal-ring area **318** involves roughening the seal-ring area by chemical etching, laser ablating, mechanical grinding or sandblasting this area. This roughening increases the surface area of the sheet seal-ring, thereby providing increased adhesion for the subsequently deposited metalization materials.

[0054] Referring now to FIG. 5, there is illustrated a portion of the sheet **304** which has been placed bottom side up to better illustrate the preparation of the sheet seal-ring area **318**. In this example the seal-ring area **318** has been given a roughened surface **501** to improve adhesion of the metallic layers to be applied. Chemical etching to roughen glass and similar transparent materials is well known. Alternatively, laser ablating, conventional mechanical grinding or sandblasting may be used. A grinding wheel with 325 grit is believed suitable for most glass materials, while a diamond grinding wheel may be used for sapphire and other hardened materials. The depth **502** to which the roughened surface **501** of the sheet seal-ring area **318** penetrates the sheet **304** is dependent on at least two factors: first, the desired mounting height of the bottom surface **316** of the window relative to the package bottom and/or the micro-device **112** mounted inside the package; and second, the required thickness of the frame **306** including all of the deposited metal layers (described below). It is believed that etching or grinding the sheet seal-ring area **318** to a depth of **502** within the range from about 0 inches to about 0.05 inches will provide a satisfactory adhesion for the metallized layers as well as providing an easily detectable “lip” for locating the sheet **304** in the proper position against the frame **306** during subsequent joining operations.

[0055] It will be appreciated that it may be necessary or desirable to protect the finished surfaces **314** and/or **316** in the window portion **312** of the sheet (e.g., the portions that will be optically active in the finished cover assembly) from damage during the roughening process. If so, the surfaces **314** and/or **316** may be covered with semiconductor-grade “tacky tape” or other known masking materials prior to roughening. The mask material must, of course, be removed in areas where the etching/grinding will take place. Sandblasting is probably the most economical method of selectively removing strips of tape or masking material in the regions that will be roughened. If sandblasting is used, it could simultaneously perform the tape removal operation and the roughening of the underlying sheet.

[0056] Referring now to FIG. 6, there is illustrated a view of the seal-ring area **318** of the sheet **304** after metalization. The next step of the manufacturing process is to apply one or more metallic layers to the prepared sheet seal-ring area **318**. The current invention contemplates several options for accomplishing this metalization. A first option is to apply metal layers to the sheet seal-ring area **318** using conventional chemical vapor deposition (CVD) technology. CVD technology includes atmospheric pressure chemical vapor deposition (APCVD), low pressure chemical vapor deposition (LPCVD), plasma assisted (enhanced) chemical vapor deposition (PACVD, PECVD), photochemical vapor deposition (PCVD), laser chemical vapor deposition (LCVD), metal-organic chemical vapor deposition (MOCVD) and chemical beam epitaxy (CBE). A second option for metalizing the

roughened seal-ring area **318** is using physical vapor deposition (PVD) technology. PVD technology includes sputtering, ion plasma assist, thermal evaporation, vacuum evaporation, and molecular beam epitaxy (MBE). A third option for metalizing the roughened sheet seal-ring area **318** is using solution bath plating technology (SBP). Solution bath plating includes electroplating, electroless plating and electrolytic plating technology. While solution bath plating cannot be used for depositing the initial metal layer onto a nonmetallic surface such as glass or plastic, it can be used for depositing subsequent layers of metal or metal alloy to the initial layer. Further, it is envisioned that in many cases, solution bath plating will be the most cost effective metal deposition technique. Since the use of chemical vapor deposition, physical vapor deposition and solution bath plating to deposit metals and metal alloys is well known, these techniques will not be further described herein.

[0057] A fourth option for metalizing the sheet seal-ring area **318** of the sheet **304** is so-called cold-gas dynamic spray technology, also known as “cold-spray”. This technology involves the spraying of powdered metals, alloys, or mixtures of metal and alloys onto an article using a jet of high velocity gas to form continuous metallic coating at temperatures well below the fusing temperatures of the powdered material. Details of the cold-gas dynamic spray deposition technology are disclosed in U.S. Pat. No. 5,302,414 to Alkhimov et al. It has been determined that aluminum provides good results when applied to glass using the cold-gas dynamic spray deposition. The aluminum layer adheres extremely well to the glass and may create a chemical bond in the form of aluminum silicate. However, other materials may also be applied as a first layer using cold-spray, including tin, zinc, silver and gold. Since the cold-gas dynamic spray technology can be used at low temperatures (e.g., near room temperature), it is suitable for metalizing materials having a relatively low melting point, such as polycarbonates or other plastics, as well as for metalizing conventional materials such as glass, alumina and ceramics.

[0058] For the initial metallic layer deposited on the sheet **304**, it is believed that any of chromium, nickel, aluminum, tin, tin-bismuth alloy, gold, gold-tin alloy can be used, this list being given in order of increasing adhesion to glass. Any of these materials can be applied to the sheet seal-ring area **318** using any of the CVD or PVD technologies (e.g., sputtering) previously described. After the initial layer **602** is deposited onto the sheet seal-ring area **318** of the nonmetallic sheet **304**, additional metal layers, e.g., second layer **604**, third layer **606** and fourth layer **608** (as applicable) can be added by any of the deposition methods previously described, including solution bath plating. It is believed that the application of the following rules will result in satisfactory thicknesses for the various metal layers. Rule No. 1: the minimum thickness, except for the aluminum or tin-based metals or alloys which will be bonded to the gold-plated Kovar alloy frame: 0.002 microns. Rule 2: the minimum thickness for aluminum or tin-based metals or alloys deposited onto the sheet or as the final layer, which will be bonded to the gold-plated Kovar alloy frame: 0.8 microns. Rule 3: the maximum thickness for aluminum or tin-based metals or alloys deposited onto the sheet or as the final layer, which will be bonded to the gold-plated Kovar alloy frame: 63.5 microns. Rule 4: the maximum thickness for metals, other than chromium, deposited onto the sheet as the first layer and which will have other metals or alloys deposited on top of them: 25 microns. Rule 5: the maximum thick-

ness for metals, other than chromium, deposited onto other metals or alloys as intermediate layers: 6.35 microns. Rule 6: the minimum thickness for metals or alloys deposited onto the sheet or as the final layer, which will act as the solder for attachment to the gold-plated Kovar alloy frame: 7.62 microns. Rule 7: the maximum thickness for metals or alloys deposited onto the sheet or as the final layer, which will act as the solder for attachment to the gold-plated Kovar alloy frame: 101.6 microns. Rule 8: the maximum thickness for chromium: 0.25 microns. Rule 9: the minimum thickness for gold-tin solder, applied via inkjet or supplied as a solder preform: 6 microns. Rule 10: the maximum thickness for gold-tin solder, applied via inkjet or supplied as a solder preform: 101.6 microns. Rule 11: The minimum thickness for immersion zinc; 0.889 microns. Note that the above rules apply to metals deposited using all deposition methods other than cold-gas dynamic spray deposition.

[0059] For cold spray applications, the following rules apply: Rule 1: the minimum practical thickness for any metal layer: 2.54 microns. Rule 2: the maximum practical thickness for the first layer, and all additional layers, but not including the final Kovar alloy layer: 127 microns. Rule 3: the maximum practical thickness for the final Kovar alloy layer: 12,700 microns, i.e., 0.5 inches.

[0060] By way of example, not to be considered limiting, the following metal combinations are believed suitable for seal-ring area 318 when bonding the prepared sheet 304 to a Kovar alloy-nickel-gold frame 302 (i.e., Kovar alloy core plated first with nickel and then with gold) using thermal compression (TC) bonding, or sonic, ultrasonic or thermosonic bonding.

EXAMPLE 1

[0061]

Layers	Metal	Deposition	Min. (microns)	Max. (microns)
1	Al	CVD, PVD	0.7	63.5

EXAMPLE 2

[0062]

Layers	Metal	Deposition	Min. (microns)	Max. (microns)
1	Al	CVD, PVD	0.002	25
2	Cu	CVD, PVD, SBP	0.002	6.35
3	Ni	CVD, PVD, SBP	0.002	6.35
4	Sn or SnBi	CVD, PVD, SBP	0.7	63.5

EXAMPLE 3

[0063]

Layers	Metal	Deposition	Min. (microns)	Max. (microns)
1	Al	CVD, PVD	0.002	25
2	Zn	CVD, PVD, SBP	0.002	6.35

-continued

Layers	Metal	Deposition	Min. (microns)	Max. (microns)
3	Ni	CVD, PVD, SBP	0.002	6.35
4	Sn or Sn—Bi	CVD, PVD, SBP	0.7	63.5

EXAMPLE 4

[0064]

Layers	Metal	Deposition	Min. (microns)	Max. (microns)
1	Al	CVD, PVD	0.002	25
2	Zn	CVD, PVD, SBP	0.002	6.35
3	Sn or Sn—Bi	CVD, PVD, SBP	0.7	63.5

EXAMPLE 5

[0065]

Layers	Metal	Deposition	Min. (microns)	Max. (microns)
1	Sn (de-stressed)	CVD, PVD	0.002	25
2	Cu	CVD, PVD, SBP	0.002	6.35
3	Ni	CVD, PVD, SBP	0.002	6.35
4	Sn or Sn—Bi	CVD, PVD, SBP	0.7	63.5

EXAMPLE 6

[0066]

Layers	Metal	Deposition	Min. (microns)	Max. (microns)
1	Sn—Bi	CVD, PVD	0.7	63.5

EXAMPLE 7

[0067]

Layers	Metal	Deposition	Min. (microns)	Max. (microns)
1	Cr	CVD, PVD	0.002	0.15
2	Ni	CVD, PVD, SBP	0.002	6.35
3	Sn or Sn—Bi	CVD, PVD, SBP	0.7	63.5

EXAMPLE 8

[0068]

Layers	Metal	Deposition	Min. (microns)	Max. (microns)
1	Cr	CVD, PVD	0.002	0.15
2	Ni	CVD, PVD, SBP	0.002	6.35
3	Al	CVD, PVD, SBP	0.7	63.5

EXAMPLE 9

[0069]

Layers	Metal	Deposition	Min. (microns)	Max. (microns)
1	Cr	CVD, PVD	0.002	0.15
2	Ni	CVD, PVD, SBP	0.002	6.35
3	Zn	CVD, PVD, SBP	0.002	6.35
4	Al	CVD, PVD, SBP	0.7	63.5

EXAMPLE 10

[0070]

Layers	Metal	Deposition	Min. (microns)	Max. (microns)
1	Ni	CVD, PVD	0.002	152.4
2	Sn or Sn—Bi	CVD, PVD, SBP	0.7	63.5

EXAMPLE 11

[0071]

Layers	Metal	Deposition	Min. (microns)	Max. (microns)
1	Ni	CVD, PVD	0.002	152.4
2	Al	CVD, PVD, SBP	0.7	63.5

EXAMPLE 12

[0072]

Layers	Metal	Deposition	Min. (microns)	Max. (microns)
1	Ni	CVD, PVD	0.002	152.4
2	Zn	CVD, PVD, SBP	0.002	6.35
3	Al	CVD, PVD, SBP	0.7	63.5

EXAMPLE 13

[0073]

Layers	Metal	Deposition	Min. (microns)	Max. (microns)
1	Sn	CVD, PVD	0.7	63.5

EXAMPLE 14

[0074]

Layers	Metal	Deposition	Min. (microns)	Max. (microns)
1	Cr	CVD, PVD	0.002	0.15

EXAMPLE 15

[0075]

Layers	Metal	Deposition	Min. (microns)	Max. (microns)
1	Ni	CVD, PVD	0.002	152.4

EXAMPLE 16

[0076]

Layers	Metal	Deposition	Min. (microns)	Max. (microns)
1	Sn—Bi	CVD, PVD	0.7	63.5

[0077] By way of further example, not to be considered limiting, the following metal combinations and thicknesses are preferred for seal-ring area **318** when bonding the prepared sheet **304** to a Kovar alloy-nickel-gold frame **302** using thermal compression (TC) bonding, or sonic, ultrasonic or thermosonic bonding.

EXAMPLE 17

[0078]

Layers	Metal	Deposition	Min. (microns)	Max. (microns)
1	Al	CVD, PVD	1	50.8

EXAMPLE 18

[0079]

Layers	Metal	Deposition	Min. (microns)	Max. (microns)
1	Al	CVD, PVD	0.1	2.54
2	Cu	CVD, PVD, SBP	0.25	2.54
3	Ni	CVD, PVD, SBP	1	5.08
4	Sn or SnBi	CVD, PVD, SBP	1	50.8

EXAMPLE 19

[0080]

Layers	Metal	Deposition	Min. (microns)	Max. (microns)
1	Al	CVD, PVD	0.1	2.54
2	Zn	CVD, PVD, SBP	0.3175	5.08
3	Ni	CVD, PVD, SBP	1	5.08
4	Sn or Sn—Bi	CVD, PVD, SBP	1	50.8

EXAMPLE 20

[0081]

Layers	Metal	Deposition	Min. (microns)	Max. (microns)
1	Al	CVD, PVD	0.1	2.54
2	Zn	CVD, PVD, SBP	0.3175	5.08
3	Sn or Sn—Bi	CVD, PVD, SBP	1	50.8

EXAMPLE 21

[0082]

Layers	Metal	Deposition	Min. (microns)	Max. (microns)
1	Sn (de-stressed)	CVD, PVD	0.1	2.54
2	Cu	CVD, PVD, SBP	0.25	2.54
3	Ni	CVD, PVD, SBP	1	5.08
4	Sn or Sn—Bi	CVD, PVD, SBP	1	50.8

EXAMPLE 22

[0083]

Layers	Metal	Deposition	Min. (microns)	Max. (microns)
1	Sn—Bi	CVD, PVD	1	50.8

EXAMPLE 23

[0084]

Layers	Metal	Deposition	Min. (microns)	Max. (microns)
1	Cr	CVD, PVD	0.05	0.12
2	Ni	CVD, PVD, SBP	1	5.08
3	Sn or Sn—Bi	CVD, PVD, SBP	1	50.8

EXAMPLE 24

[0085]

Layers	Metal	Deposition	Min. (microns)	Max. (microns)
1	Cr	CVD, PVD	0.05	0.12
2	Ni	CVD, PVD, SBP	1	5.08
3	Al	CVD, PVD, SBP	1	50.8

EXAMPLE 25

[0086]

Layers	Metal	Deposition	Min. (microns)	Max. (microns)
1	Cr	CVD, PVD	0.05	0.12
2	Ni	CVD, PVD, SBP	1	5.08
3	Zn	CVD, PVD, SBP	0.3175	5.08
4	Al	CVD, PVD, SBP	1	50.8

EXAMPLE 26

[0087]

Layers	Metal	Deposition	Min. (microns)	Max. (microns)
1	Ni	CVD, PVD	0.1	5.08
2	Sn or Sn—Bi	CVD, PVD, SBP	1	50.8

EXAMPLE 27

[0088]

Layers	Metal	Deposition	Min. (microns)	Max. (microns)
1	Ni	CVD, PVD	0.1	5.08
2	Al	CVD, PVD, SBP	1	50.8

EXAMPLE 28

[0089]

Layers	Metal	Deposition	Min. (microns)	Max. (microns)
1	Ni	CVD, PVD	0.1	5.08
2	Zn	CVD, PVD, SBP	0.3175	5.08
3	Al	CVD, PVD, SBP	1	50.8

EXAMPLE 29

[0090]

Layers	Metal	Deposition	Min. (microns)	Max. (microns)
1	Sn	CVD, PVD	1	50.8

EXAMPLE 30

[0091]

Layers	Metal	Deposition	Min. (microns)	Max. (microns)
1	Cr	CVD, PVD	0.05	0.12

EXAMPLE 31

[0092]

Layers	Metal	Deposition	Min. (microns)	Max. (microns)
1	Ni	CVD, PVD	0.1	50.8

EXAMPLE 32

[0093]

Layers	Metal	Deposition	Min. (microns)	Max. (microns)
1	Sn—Bi	CVD, PVD	1	50.8

[0094] As indicated above, the previous examples are believed suitable for application of, among other processes, thermal compression bonding. TC bonding, also referred to as “diffusion bonding” or “diffusion welding” in various disciplines, is a process of diffusion bonding in which two prepared surfaces are brought into intimate contact, and plastic deformation is induced by the combined effect of pressure and temperature, which in turn results in atom movement causing the development of a crystal lattice bridging the gap between facing surfaces and resulting in bonding. TC bonding takes place at significantly lower temperatures than many other forms of bonding such as braze soldering.

[0095] Referring now to FIG. 7, there is illustrated a cross-sectional view of the prefabricated frame 302 suitable for use in this embodiment. The illustrated frame 302 includes a Kovar alloy core 702 overlaid with a first metallic layer 704 of nickel which, in turn, is overlaid by an outer layer 706 of gold. The use of Kovar alloy for the core 702 of the frame 302 is preferred where hard glass, e.g., Corning 7056 or 7058, is used for the sheet 304 and where Kovar alloy or a similar material is used for the package base 104, since these materials have a CTE for the temperature range 30° C. to 300° C. that is within the range from about $5.0 \cdot 10^{-6}/^{\circ}\text{K}$ to about $5.6 \cdot 10^{-6}/^{\circ}\text{K}$ (e.g. from about 5.0 to about 5.6 ppm/ $^{\circ}\text{K}$).

[0096] Referring still to FIG. 7, another step of the manufacturing process is the preparation of a prefabricated frame 302 for joining to the sheet 304. As previously described, the frame 302 includes a continuous sidewall 306 which defines an aperture 308 therethrough. The sidewall 306 includes a frame seal-ring area 310 on its upper surface and a base seal-ring area 320 on its lower surface. The frame seal-ring area 310 is generally dimensioned to conform with the sheet seal-ring area 318 of the transparent sheet 304, while the base seal-ring area 320 is dimensioned to conform against the corresponding seal area on the package base. The frame 302 may be manufactured using various conventional metal forming technologies, including stamping, casting, die casting, extrusion/parting, and machining. It is contemplated that stamping or die casting will be the most cost effective method for producing the frames 302. Depending upon the degree of flatness required for the contemplated bonding procedure and the degree achieved by a particular frame manufacturing method, surface grinding, and possibly even lapping or polishing, may be required on the frame seal-ring area 310 or base seal-ring area 320, to provide the final flatness necessary for a successful hermetic seal.

[0097] In this example, the base seal-ring area 320 is on the frame face opposite frame seal-ring area 310, and utilizes the same layers of nickel 704 overlaid by gold 706 to facilitate eventual welding to the package base 104.

[0098] It is important for the frame 302 to serve as a “heat sink” and “heat spreader” when the cover assembly 300 is eventually welded to the package base 104. It is contemplated that conventional high temperature welding processes (e.g., automatic resistance seam welding or laser welding) will be used for this operation. If the metallized glass sheet 304 was welded directly to the package base 104 using these welding processes, the concentrated heat would cause thermal stresses likely to crack the glass sheet or distort its optical properties. However, when a metal frame is attached to the transparent sheet, it acts as both a heat sink, absorbing some of the heat of welding, and as a heat spreader, distributing the heat over a wider area such that the thermal stress on the transparent sheet 304 is reduced to minimize the likelihood of cracking or optical distortion. Kovar alloy is especially useful in this heat sink and heat spreading role as explained by Kovar alloy’s thermal conductivity, 0.0395, which is approximately fourteen times higher than the thermal conductivity of Corning 7052 glass, 0.0028.

[0099] Another important aspect of the frame 302 is that it must be formed from a material having a CTE that is similar to the CTE of the transparent sheet 304 and the CTE of the package base 104. This matching of CTE between the frame 302, transparent sheet 304 and package base 104 is required to minimize stresses between these components after they are joined to one another so as to ensure the long term reliability of the hermetic seal therebetween under conditions of thermal cycling and/or thermal shock environments.

[0100] For window assemblies that will be attached to package bases formed of ceramic, alumina or Kovar alloy, Kovar alloy is preferred for use as the material for the frame 304. Although Kovar alloy will be used for the frames in many of the embodiments discussed in detail herein, it will be understood that Kovar alloy is not necessarily suitable for use with all transparent sheet materials. Additionally, other frame materials besides Kovar alloy may be suitable for use with glass. Suitability is determined by the necessity that the material of the transparent sheet 304, the material of the frame 302 and the material of the package base 104 all have closely matching CTEs to insure maximum long-term reliability of the hermetic seals.

[0101] Referring now to FIG. 8, the next step of the manufacturing process is to position the frame 302 against the sheet 304 such that at least a portion of the frame seal-ring area 310 and a least a portion of the sheet seal-ring area 318 contact one another along a continuous junction region 804 that circumscribes the window portion 312. Actually, in some cases a plasma-cleaning operation is performed on the seal-ring areas and any other sealing surfaces just prior to joining the components to ensure maximum reliability of the joint. In FIG. 8, the sheet 304 moves from its original position (denoted in broken lines) until it is in contact with the frame 302. It is, of course, first necessary to remove any remaining tacky tape or other masking materials left over from operations used to prepare the sheet seal-ring area 318 if they cannot withstand the elevated temperatures encountered in the joining process without degradation of the mask material and/or its adhesive, if an adhesive is used to attach the mask to the sheet. It will be appreciated that it is not necessary that the sheet seal-ring area 318 and the frame seal-ring area 310 have an exact correspon-

dence with regard to their entire areas, rather, it is only necessary that there be some correspondence between the two seal-ring areas forming a continuous junction region **804** which circumscribes the window portion **312**. In the embodiment illustrated in FIG. 8, the metallized layers **610** in the sheet seal-ring area **318** are much wider than the plated outer layer **706** of the frame seal-ring area **310**. Further, the window portion **312** of the sheet **304** extends partway through the frame aperture **308**, providing a means to center the sheet **304** on the frame **302**.

[0102] The next step of the manufacturing process is to heat the junction region **804** until a metal-to-metal joint is formed between the frame **302** and the sheet **304** all along the junction region, whereby a hermetic seal circumscribing the window portion **312** is formed. It is necessary that during the step of heating the junction region **804**, the temperature of the window portion **312** of the sheet **304** remain below its glass transition temperature, T_G to prevent damage to the finished surfaces **314** and **316**. The current invention contemplates several options for accomplishing this heating. A first option is to utilize thermal compression (TC) bonding, also known as diffusion bonding or diffusion welding. As previously described, TC bonding involves the application of high pressures to the materials being joined such that a reduced temperature is required to produce the necessary diffusion bond. Rules for determining the thickness and composition of the metallic layers **610** on the sheet **304** were previously provided, for TC bonding to, e.g., a Kovar alloy, nickel or gold frame such as illustrated in FIG. 7. The estimated process parameters for the TC bonding of a Kovar alloy/nickel/gold frame **302** to a metallized sheet **304** having aluminum as the final layer would be a temperature of approximately 380°C . at an applied pressure of approximately 95,500 psi. Under these conditions, the gold plating **706** on the Kovar alloy frame **302** will diffuse into/with the aluminum layer, e.g., layer **4** in Example 7. Since the 380°C . temperature necessary for TC bonding is below the approximately 500°C . to 900°C . T_G for hard glasses such as Corning 7056, the TC bonding process could be performed in a single or batch mode by fixturing the cover assembly components **302**, **304** together in compression and placing the compressed assemblies into a furnace (or oven, etc.) at approximately 380°C . The hermetic bond would be obtained without risking the finished surfaces **314** and **316** of the window portion **312**.

[0103] Alternatively, employing resistance welding at the junction area **804** to add additional heat in addition to the TC bonding could allow preheating the window assemblies to less than 380°C . and possibly reduce the overall bonding process time. In another method, the TC bonding could be accomplished by fixturing the cover assembly components **302** and **304** using heated tooling that would heat the junction area **304** by conduction. In yet another alternative method, resistance welding can be used to supply 100% of the heat required to achieve the necessary TC bonding temperature, thereby eliminating the need for furnaces, ovens, etc. or specialized thermally conductive tooling.

[0104] After completion of TC bonding or other welding processes, the window assembly **300** is ready for final processing, for example, chamfering the edges of the cover assembly to smooth them and prevent chipping, scratching, marking, etc., during post-assembly, cleaning, marking or other operations.

[0105] Referring now to FIG. 9, there is illustrated a block diagram of the manufacturing process just described in accor-

dance with one embodiment of the current invention. Block **902** represents the step of obtaining a sheet of transparent material, e.g., glass or other material, having finished top and bottom surfaces as previously described. The process then proceeds to block **904** as indicated by the arrow.

[0106] Block **904** represents the step of applying surface treatments to the sheet, e.g. scratch-resistant or anti-reflective coatings, as previously described. In addition to these permanent surface treatments, block **904** also represents the sub-steps of applying tape or other temporary masks to the surfaces of the sheet to protect them during the subsequent steps of the process. It will be appreciated that the steps represented by block **904** are optional and that one or more of these steps may not be present in every embodiment of the invention. The process then proceeds to block **906** as indicated by the arrow.

[0107] Block **906** represents the step of preparing the seal-ring area on the sheet to provide better adhesion for the required metallic layers. This step usually involves roughening the seal-ring area using chemical etching, mechanical grinding, laser ablating or sandblasting as previously described. To the extent necessary, block **906** also represents the sub-steps of removing any masking material from the seal-ring area. It will be appreciated that the steps represented by block **906** are optional and that some or all of these steps may not be present in every embodiment of the invention. The process then proceeds to block **908** as indicated by the arrow.

[0108] Block **908** represents the step of metallizing the seal-ring areas of the sheet. The step represented by block **908** is mandatory since at least one metallic layer must be applied to the seal-ring area of the sheet. In most embodiments, block **908** will represent numerous sub-steps for applying successive metallic layers to the sheet, where the layers of each sub-step may be applied by processes including CVD, PVD, cold-spray or solution bath plating as previously described. Following the steps represented by block **908**, the sheet is ready for joining to the frame. However, before the process can proceed to this joining step (i.e., block **916**), a suitable frame must first be prepared.

[0109] Block **910** represents the step of obtaining a pre-fabricated frame having a CTE that closely matches the CTE of the transparent sheet from block **902** and the CTE of the package base. In most cases where the base is alumina or Kovar alloy, a frame formed of Kovar alloy will be suitable. As previously described, the frame may be formed using, e.g., stamping die-casting or other known metal-forming processes. The process then proceeds to block **912** as indicated by the arrow.

[0110] Block **912** represents the step of grinding, polishing and/or otherwise flattening the seal-ring areas of the frame as necessary to increase its flatness so that it will fit closely against the seal-ring areas of the transparent sheet. It will be appreciated that the steps represented by block **912** are optional and may not be necessary or present in every embodiment of the invention. The process then proceeds to block **914** as indicated by the arrow.

[0111] Block **914** represents the step of applying additional metallic layers to the seal-ring areas of the frame. These metallic layers are frequently necessary to achieve compatible chemistry for bonding with the metallized seal-ring areas of the transparent sheet. In most embodiments, block **914** will represent numerous sub-steps for applying successive metallic layers to the frame. Once the steps represented by block **914** are completed, the frame is ready for joining to the

transparent sheet. Thus, the results of process block **908** and block **914** both proceed to block **916** as indicated by the arrows.

[0112] Block **916** represents the step of clamping the prepared frame together with the prepared transparent sheet so that their respective metallized seal-ring areas are in contact with one another under conditions producing a predetermined contact pressure at the junction region circumscribing the window portion. This predetermined contact pressure between the seal-ring surfaces allows thermal compression (TC) bonding of the metallized surfaces to occur at a lower temperature than would be required for conventional welding (including most soldering and brazing processes). The process then proceeds to block **918** as indicated by the arrow.

[0113] Block **918** represents the step of applying heat to the junction between the frame and the transparent sheet while maintaining the predetermined contact pressure until the temperature is sufficient to cause thermal compression bonding to occur. In some embodiments, block **918** will represent a single heating step, e.g. heating the fixtured assembly in a furnace. In other embodiments, block **918** will represent several sub-steps for applying heat to the junction area, for example, first preheating the fixtured assembly (e.g., in a furnace) to an intermediate temperature, and then using resistance welding techniques along the junction to raise the temperature of the localized area of the metallic layers the rest of the way to the temperature where thermal compression bonding will occur. The thermal compression bonding creates a hermetic seal between the transparent sheet material and the frame. The process then proceeds to block **920** as indicated by the arrow.

[0114] Block **920** represents the step of completing the window assembly. Block **920** may represent merely cooling the window assembly after thermal compression bonding, or it may represent additional finishing processes including chamfering the edges of the assembly to prevent chipping, cracking, etc., marking the assembly, or other post-assembly procedures. The process of this embodiment has thus been described.

[0115] It will be appreciated that in alternative embodiments of the invention, conventional welding techniques (including soldering and/or brazing) may be used instead of thermal compression bonding to join the frame to the transparent sheet. In such alternative embodiments, the steps represented by blocks **916** and **918** of FIG. **9** would be replaced by the steps of fixturing the frame and transparent sheet together so that the metallized seal-ring areas are in contact with one another (but not necessarily producing a predetermined contact pressure along the junction) and then applying heat to the junction area using conventional means until the temperature is sufficient to cause the melting and diffusing of the metallic layers necessary to achieve the welded bond.

[0116] In an alternative embodiment, braze-soldering is used to join the frame **302** to the metallized sheet **304**. In this embodiment, a solder metal or solder alloy is utilized as the final layer of the metallic layers **610** on the metallized sheet **304**, and clamping the sheet **304** to the frame **302** at a high predetermined contact pressure is not required. Light to moderate clamping pressure can be used: 1) to insure alignment during the solder's molten phase; and 2) to promote even distribution of the molten solder all along the junction region between the respective seal-ring areas; thereby helping to insure a hermetic seal, however, this clamping pressure does not contribute to the bonding process itself as in TC bonding.

In most other respects, however, this embodiment is substantially similar to that previously described.

[0117] The following examples, not to be considered limiting, are provided to illustrate the details of the metallic layers **610** in the sheet seal-ring area **318** that are suitable for braze-soldering to a Kovar alloy/nickel/gold frame **302** such as that illustrated in FIG. **7**.

EXAMPLE 33

[0118]

Layers	Metal	Deposition	Min. (microns)	Max. (microns)
1	Al	CVD, PVD	0.002	25
2	Cu	CVD, PVD, SBP	0.002	6.35
3	Ni	CVD, PVD, SBP	0.002	6.35
4	Eutectic Au—Sn solder	CVD, PVD, SBP	1.27	127

EXAMPLE 34

[0119]

Layers	Metal	Deposition	Min. (microns)	Max. (microns)
1	Al	CVD, PVD	0.002	25
2	Cu	CVD, PVD, SBP	0.002	6.35
3	Ni	CVD, PVD, SBP	0.002	6.35
4	Sn—Bi solder	CVD, PVD, SBP	1.27	152.4

EXAMPLE 35

[0120]

Layers	Metal	Deposition	Min. (microns)	Max. (microns)
1	Al	CVD, PVD	0.002	25
2	Zn	CVD, PVD, SBP	0.002	6.35
3	Ni	CVD, PVD, SBP	0.002	6.35
4	Eutectic Au—Sn solder	CVD, PVD, SBP	1.27	127

EXAMPLE 36

[0121]

Layers	Metal	Deposition	Min. (microns)	Max. (microns)
1	Al	CVD, PVD	0.002	25
2	Zn	CVD, PVD, SBP	0.002	6.35
3	Ni	CVD, PVD, SBP	0.002	6.35
4	Sn—Bi solder	CVD, PVD, SBP	1.27	152.4

EXAMPLE 37

[0122]

Layers	Metal	Deposition	Min. (microns)	Max. (microns)
1	Cr	CVD, PVD	0.002	0.15
2	Zn	CVD, PVD, SBP	0.002	6.35
3	Ni	CVD, PVD, SBP	0.002	6.35
4	Eutectic Au—Sn solder	CVD, PVD, SBP	1.27	127

EXAMPLE 38

[0123]

Layers	Metal	Deposition	Min. (microns)	Max. (microns)
1	Cr	CVD, PVD	0.002	0.15
2	Ni	CVD, PVD, SBP	0.002	6.35
3	Eutectic Au—Sn solder	CVD, PVD, SBP	1.27	127

EXAMPLE 39

[0124]

Layers	Metal	Deposition	Min. (microns)	Max. (microns)
1	Cr	CVD, PVD	0.002	0.15
2	Zn	CVD, PVD, SBP	0.002	6.35
3	Ni	CVD, PVD, SBP	0.002	6.35
4	Sn—Bi solder	CVD, PVD, SBP	1.27	152.4

EXAMPLE 40

[0125]

Layers	Metal	Deposition	Min. (microns)	Max. (microns)
1	Cr	CVD, PVD	0.002	0.15
2	Ni	CVD, PVD, SBP	0.002	6.35
3	Sn—Bi solder	CVD, PVD, SBP	1.27	152.4

EXAMPLE 41

[0126]

Layers	Metal	Deposition	Min. (microns)	Max. (microns)
1	Cr	CVD, PVD	0.002	0.15
2	Sn—Bi solder	CVD, PVD, SBP	1.27	152.4

EXAMPLE 42

[0127]

Layers	Metal	Deposition	Min. (microns)	Max. (microns)
1	De-stressed Sn Solder	CVD, PVD	1.27	152.4

EXAMPLE 43

[0128]

Layers	Metal	Deposition	Min. (microns)	Max. (microns)
1	Sn—Bi Solder	CVD, PVD	1.27	152.4

EXAMPLE 44

[0129]

Layers	Metal	Deposition	Min. (microns)	Max. (microns)
1	Eutectic Au—Sn Solder	CVD, PVD	1.27	127

EXAMPLE 45

[0130]

Layers	Metal	Deposition	Min. (microns)	Max. (microns)
1	Ni	CVD, PVD	0.002	152.4
2	Eutectic Au—Sn Solder	CVD, PVD, SBP	1.27	127

EXAMPLE 46

[0131]

Layers	Metal	Deposition	Min. (microns)	Max. (microns)
1	Ni	CVD, PVD	0.002	152.4
2	Sn—Bi Solder	CVD, PVD, SBP	1.27	152.4

[0132] By way of further examples, not to be considered limiting, the following combinations are preferred for the metallic layers **610** in the sheet seal-ring area **318** for braze-soldering to a Kovar alloy/nickel/gold frame **302** such as that illustrated in FIG. 7.

EXAMPLE 47

[0133]

Layers	Metal	Deposition	Min. (microns)	Max. (microns)
1	Al	CVD, PVD	0.1	2.54
2	Cu	CVD, PVD, SBP	0.25	2.54
3	Ni	CVD, PVD, SBP	1	5.08
4	Eutectic Au—Sn solder	CVD, PVD, SBP	2.54	63.5

EXAMPLE 48

[0134]

Layers	Metal	Deposition	Min. (microns)	Max. (microns)
1	Al	CVD, PVD	0.1	2.54
2	Cu	CVD, PVD, SBP	0.25	2.54
3	Ni	CVD, PVD, SBP	1	5.08
4	Sn—Bi solder	CVD, PVD, SBP	2.54	127

EXAMPLE 49

[0135]

Layers	Metal	Deposition	Min. (microns)	Max. (microns)
1	Al	CVD, PVD	0.1	2.54
2	Zn	CVD, PVD, SBP	0.3175	5.08
3	Ni	CVD, PVD, SBP	1	5.08
4	Eutectic Au—Sn solder	CVD, PVD, SBP	2.54	63.5

EXAMPLE 50

[0136]

Layers	Metal	Deposition	Min. (microns)	Max. (microns)
1	Al	CVD, PVD	0.1	2.54
2	Zn	CVD, PVD, SBP	0.3175	5.08
3	Ni	CVD, PVD, SBP	1	5.08
4	Sn—Bi solder	CVD, PVD, SBP	2.54	127

EXAMPLE 51

[0137]

Layers	Metal	Deposition	Min. (microns)	Max. (microns)
1	Cr	CVD, PVD	0.05	0.12
2	Zn	CVD, PVD, SBP	0.3175	5.08

-continued

Layers	Metal	Deposition	Min. (microns)	Max. (microns)
3	Ni	CVD, PVD, SBP	1	5.08
4	Eutectic Au—Sn solder	CVD, PVD, SBP	2.54	63.5

EXAMPLE 52

[0138]

Layers	Metal	Deposition	Min. (microns)	Max. (microns)
1	Cr	CVD, PVD	0.05	0.12
2	Ni	CVD, PVD, SBP	1	5.08
3	Eutectic Au—Sn solder	CVD, PVD, SBP	2.54	63.5

EXAMPLE 53

[0139]

Layers	Metal	Deposition	Min. (microns)	Max. (microns)
1	Cr	CVD, PVD	0.05	0.12
2	Zn	CVD, PVD, SBP	0.3175	5.08
3	Ni	CVD, PVD, SBP	1	5.08
4	Sn—Bi solder	CVD, PVD, SBP	2.54	127

EXAMPLE 54

[0140]

Layers	Metal	Deposition	Min. (microns)	Max. (microns)
1	Cr	CVD, PVD	0.05	0.12
2	Ni	CVD, PVD, SBP	1	5.08
3	Sn—Bi solder	CVD, PVD, SBP	2.54	127

EXAMPLE 55

[0141]

Layers	Metal	Deposition	Min. (microns)	Max. (microns)
1	Cr	CVD, PVD	0.05	0.12
2	Sn—Bi solder	CVD, PVD, SBP	2.54	127

EXAMPLE 56

[0142]

Layers	Metal	Deposition	Min. (microns)	Max. (microns)
1	De-stressed Sn Solder	CVD, PVD	2.54	127

EXAMPLE 57

[0143]

Layers	Metal	Deposition	Min. (microns)	Max. (microns)
1	Sn—Bi Solder	CVD, PVD	2.54	127

EXAMPLE 58

[0144]

Layers	Metal	Deposition	Min. (microns)	Max. (microns)
1	Eutectic Au—Sn Solder	CVD, PVD	2.54	63.5

EXAMPLE 59

[0145]

Layers	Metal	Deposition	Min. (microns)	Max. (microns)
1	Ni	CVD, PVD	0.1	5.08
2	Eutectic Au—Sn Solder	CVD, PVD, SBP	2.54	63.5

EXAMPLE 60

[0146]

Layers	Metal	Deposition	Min. (microns)	Max. (microns)
1	Ni	CVD, PVD	0.1	5.08
2	Sn—Bi Solder	CVD, PVD, SBP	2.54	127

[0147] Referring now to FIG. 10, there is illustrated yet another embodiment of the current invention. Note that in this embodiment, the cover assembly 300 is circular in configuration rather than rectangular. It will be appreciated that this is simply another possible configuration for a cover assembly manufactured in accordance with this invention, and that this embodiment is not limited to configurations of any particular shape. As in the embodiment previously described, this embodiment also uses braze-soldering to hermetically join

the transparent sheet 304 to the frame 302. However, in this embodiment, the solder is provided in the form of a separate solder preform 1000 having the shape of the sheet seal-ring area 318 or the frame seal-ring area 310.

[0148] In this embodiment, instead of positioning the frame and the sheet directly against one another, the frame 302 and the sheet 304 are instead positioned against opposite sides of the solder preform 1000 such that the solder preform is interposed between the frame seal-ring area 310 and the sheet seal-ring area 318 along a continuous junction region that circumscribes the window portion 312. After the frame 302 and sheet 304 are positioned against the solder preform 1000, the junction region is heated until the solder preform fuses forming a solder joint between the frame and sheet all along the junction region. The heating of the junction region may be performed by any of the procedures previously described, including heating or preheating in a furnace, oven, etc., either alone or in combination with other heating methods including resistance welding. It is required that during the step of heating the junction region, the temperature of the window portion 312 of the sheet 304 remain below the glass transition temperature T_G such that the finished surfaces 314 and 316 on the sheet are not adversely affected.

[0149] The current embodiment using a solder preform 1000 can be used for joining a metallized sheet 304 to a Kovar alloy/nickel/gold frame such as that illustrated in FIG. 7. In accordance with a preferred embodiment, the solder preform 1000 is formed of a gold-tin (Au—Sn) alloy, and in a more preferred embodiment, the gold-tin alloy is the eutectic composition. The thickness of the gold-tin preform 1000 will be within the range from about 6 microns to about 101.2 microns.

[0150] The following examples, not to be considered limiting, are provided to illustrate the details of the metallic layers 610 and the sheet seal-ring area 318 that are suitable for braze-soldering to a Kovar alloy/nickel/gold frame in combination with a gold-tin solder preform.

EXAMPLE 61

[0151]

Layers	Metal	Deposition	Min. (microns)	Max. (microns)
1	Al	CVD, PVD	0.002	25
2	Cu	CVD, PVD, SBP	0.002	6.35
3	Ni	CVD, PVD, SBP	0.002	6.35
4	Au	CVD, PVD, SBP	0.0508	0.508

EXAMPLE 62

[0152]

Layers	Metal	Deposition	Min. (microns)	Max. (microns)
1	Al	CVD, PVD	0.002	25
2	Cu	CVD, PVD, SBP	0.002	6.35
3	Ni	CVD, PVD, SBP	0.002	6.35
4	Sn—Bi	CVD, PVD, SBP	0.635	12.7

EXAMPLE 63

[0153]

Layers	Metal	Deposition	Min. (microns)	Max. (microns)
1	Al	CVD, PVD	0.002	25
2	Zn	CVD, PVD, SBP	0.002	6.35
3	Ni	CVD, PVD, SBP	0.002	6.35
4	Au	CVD, PVD, SBP	0.0508	0.508

EXAMPLE 64

[0154]

Layers	Metal	Deposition	Min. (microns)	Max. (microns)
1	Al	CVD, PVD	0.002	25
2	Zn	CVD, PVD, SBP	0.002	6.35
3	Ni	CVD, PVD, SBP	0.002	6.35
4	Sn—Bi	CVD, PVD, SBP	0.635	12.7

EXAMPLE 65

[0155]

Layers	Metal	Deposition	Min. (microns)	Max. (microns)
1	Cr	CVD, PVD	0.002	0.15
2	Zn	CVD, PVD, SBP	0.002	6.35
3	Ni	CVD, PVD, SBP	0.002	6.35
4	Au	CVD, PVD, SBP	0.0508	0.508

EXAMPLE 66

[0156]

Layers	Metal	Deposition	Min. (microns)	Max. (microns)
1	Cr	CVD, PVD	0.002	0.15
2	Ni	CVD, PVD, SBP	0.002	6.35
3	Au	CVD, PVD, SBP	0.0508	0.508

EXAMPLE 67

[0157]

Layers	Metal	Deposition	Min. (microns)	Max. (microns)
1	Cr	CVD, PVD	0.002	0.15
2	Zn	CVD, PVD, SBP	0.002	6.35
3	Ni	CVD, PVD, SBP	0.002	6.35
4	Sn—Bi	CVD, PVD, SBP	0.635	12.7

EXAMPLE 68

[0158]

Layers	Metal	Deposition	Min. (microns)	Max. (microns)
1	Cr	CVD, PVD	0.002	0.15
2	Ni	CVD, PVD, SBP	0.002	6.35
3	Sn—Bi	CVD, PVD, SBP	0.635	12.7

EXAMPLE 69

[0159]

Layers	Metal	Deposition	Min. (microns)	Max. (microns)
1	Cr	CVD, PVD	0.002	0.15
2	Sn—Bi	CVD, PVD, SBP	0.635	12.7

EXAMPLE 70

[0160]

Layers	Metal	Deposition	Min. (microns)	Max. (microns)
1	Cr	CVD, PVD	0.002	0.15

EXAMPLE 71

[0161]

Layers	Metal	Deposition	Min. (microns)	Max. (microns)
1	Destressed Sn or Sn—Bi	CVD, PVD	0.635	12.7

EXAMPLE 72

[0162]

Layers	Metal	Deposition	Min. (microns)	Max. (microns)
1	Au	CVD, PVD	0.0508	0.508

EXAMPLE 73

[0163]

Layers	Metal	Deposition	Min. (microns)	Max. (microns)
1	Ni	CVD, PVD	0.002	152.4
2	Au	CVD, PVD, SBP	0.0508	0.508

EXAMPLE 74

[0164]

Layers	Metal	Deposition	Min. (microns)	Max. (microns)
1	Ni	CVD, PVD	0.002	152.4
2	Sn—Bi	CVD, PVD, SBP	0.635	12.7

EXAMPLE 75

[0165]

Layers	Metal	Deposition	Min. (microns)	Max. (microns)
1	Ni	CVD, PVD	0.002	152.4
2	Sn (destressed after deposition)	CVD, PVD, SBP	0.635	12.7

[0166] By way of further examples, not to be considered limiting, the following combinations are preferred for the metallic layers 610 and the sheet seal-ring area 318 for braze-soldering to a Kovar alloy/nickel/gold frame in combination with a gold-tin soldered preform.

EXAMPLE 76

[0167]

Layers	Metal	Deposition	Min. (microns)	Max. (microns)
1	Al	CVD, PVD	0.1	2.54
2	Cu	CVD, PVD, SBP	0.25	2.54
3	Ni	CVD, PVD, SBP	1	5.08
4	Au	CVD, PVD, SBP	0.127	0.381

EXAMPLE 77

[0168]

Layers	Metal	Deposition	Min. (microns)	Max. (microns)
1	Al	CVD, PVD	0.1	2.54
2	Cu	CVD, PVD, SBP	0.25	2.54
3	Ni	CVD, PVD, SBP	1	5.08
4	Sn—Bi	CVD, PVD, SBP	2.54	7.62

EXAMPLE 78

[0169]

Layers	Metal	Deposition	Min. (microns)	Max. (microns)
1	Al	CVD, PVD	0.1	2.54
2	Zn	CVD, PVD, SBP	0.3175	5.08
3	Ni	CVD, PVD, SBP	1	5.08
4	Au	CVD, PVD, SBP	0.127	0.381

EXAMPLE 79

[0170]

Layers	Metal	Deposition	Min. (microns)	Max. (microns)
1	Al	CVD, PVD	0.1	2.54
2	Zn	CVD, PVD, SBP	0.3175	5.08
3	Ni	CVD, PVD, SBP	1	5.08
4	Sn—Bi	CVD, PVD, SBP	2.54	7.62

EXAMPLE 80

[0171]

Layers	Metal	Deposition	Min. (microns)	Max. (microns)
1	Cr	CVD, PVD	0.05	0.12
2	Zn	CVD, PVD, SBP	0.3175	5.08
3	Ni	CVD, PVD, SBP	1	5.08
4	Au	CVD, PVD, SBP	0.127	0.381

EXAMPLE 81

[0172]

Layers	Metal	Deposition	Min. (microns)	Max. (microns)
1	Cr	CVD, PVD	0.05	0.12
2	Ni	CVD, PVD, SBP	1	5.08
3	Au	CVD, PVD, SBP	0.127	0.381

EXAMPLE 82

[0173]

Layers	Metal	Deposition	Min. (microns)	Max. (microns)
1	Cr	CVD, PVD	0.05	0.12
2	Zn	CVD, PVD, SBP	0.3175	5.08
3	Ni	CVD, PVD, SBP	1	5.08
4	Sn—Bi	CVD, PVD, SBP	2.54	7.62

EXAMPLE 83

[0174]

Layers	Metal	Deposition	Min. (microns)	Max. (microns)
1	Cr	CVD, PVD	0.05	0.12
2	Ni	CVD, PVD, SBP	1	5.08
3	Sn—Bi	CVD, PVD, SBP	2.54	7.62

EXAMPLE 84

[0175]

Layers	Metal	Deposition	Min. (microns)	Max. (microns)
1	Cr	CVD, PVD	0.05	0.12
2	Sn—Bi	CVD, PVD, SBP	2.54	7.62

EXAMPLE 85

[0176]

Layers	Metal	Deposition	Min. (microns)	Max. (microns)
1	Cr	CVD, PVD	0.05	0.12

EXAMPLE 86

[0177]

Layers	Metal	Deposition	Min. (microns)	Max. (microns)
1	Destressed Sn or Sn—Bi	CVD, PVD	2.54	7.62

EXAMPLE 87

[0178]

Layers	Metal	Deposition	Min. (microns)	Max. (microns)
1	Au	CVD, PVD	0.127	0.381

EXAMPLE 88

[0179]

Layers	Metal	Deposition	Min. (microns)	Max. (microns)
1	Ni	CVD, PVD	0.1	5.08
2	Au	CVD, PVD, SBP	0.127	0.381

EXAMPLE 89

[0180]

Layers	Metal	Deposition	Min. (microns)	Max. (microns)
1	Ni	CVD, PVD	0.1	5.08
2	Sn—Bi	CVD, PVD, SBP	2.54	7.62

EXAMPLE 90

[0181]

Layers	Metal	Deposition	Min. (microns)	Max. (microns)
1	Ni	CVD, PVD	0.1	5.08
2	Sn (destressed after deposition)	CVD, PVD, SBP	2.54	7.62

[0182] Referring now to FIG. 11, there is illustrated yet another embodiment of the current invention. This embodiment also uses soldering, however, in this embodiment the solder is applied via inkjet technology to either the metallized area 610 in the sheet seal-ring area 318 or the sheet seal-ring 310 of the frame assembly. FIG. 11 shows a portion of the Kovar alloy/nickel/gold frame 302 and an inkjet dispensing head 1102 which is dispensing overlapping drops of solder 1104 onto the frame seal-ring area 310 as the dispensing head moves around the frame aperture 308 as indicated by arrow 1106. Preferably, the inkjet dispensed solder is a gold-tin (Au—Sn) alloy, and more preferably it is the eutectic composition. The thickness of the gold-tin solder applied by dispensing head 1102 in this embodiment is within the range from about 6 microns to about 101.2 microns. It will be appreciated that while the example illustrated in FIG. 11 shows the dispensing head 1102 depositing the solder droplets 1104 onto the frame 302, in other embodiments the inkjet deposited solder may be applied to the sheet seal-ring area 318, either alone or in combination with applications on the frame seal-ring area 310. In still other embodiments, the inkjet deposited solder may be used to create a discrete solder preform that would be employed as described in the previous examples herein. Details of the metallic layers 610 in the sheet seal-ring area 318 that are suitable for a soldering to a Kovar alloy/nickel/gold frame 302 such as that illustrated in FIG. 7 using inkjet supplied solder are substantially identical to those layers illustrated in previous Examples 21 through 32.

[0183] Referring now to FIGS. 12a through 12c and FIGS. 13a through 13c, there is illustrated yet another alternative method for manufacturing cover assemblies constituting another embodiment of the current invention. Whereas, in the previous embodiments a separate prefabricated metal frame was joined to the transparent sheet to act as a heat spreader/heat sink needed for subsequent welding, in this embodiment a cold gas dynamic spray deposition process is used to fabricate a metallic frame/heat spreader directly on the transparent sheet material. In other words, in this embodiment the frame is fabricated directly on the transparent sheet as an integral part, no subsequent joining operation is required. In addition, since cold gas dynamic spray deposition can be accomplished at near room temperature, this method is especially useful where the transparent sheet material and/or surface treatments thereto have a relatively low T_G , melting temperature, or other heat tolerance parameter.

[0184] Referring specifically to FIG. 12a, there is illustrated a sheet of transparent material 304 having a window portion 312 defined thereupon. The window portion 312 has finished top and bottom surfaces 314 and 316 (note that the 304 sheet appears bottom side up in FIGS. 12a through 12c). A frame attachment area 1200 is defined on the sheet 204, the frame attachment area circumscribing the window portion 312. It will be appreciated in the embodiment illustrated in FIG. 12 that the frame attachment area 1200 need not follow the specific boundaries of the window area 312 (i.e., which in this case are circular) as long as the frame attachment area 1200 completely circumscribes the window portion.

[0185] It will be appreciated that, unless specifically noted otherwise, the initial steps of obtaining a transparent sheet having a window portion with finished top and bottom surfaces, preparing the seal-ring area of the sheet and metallizing

the seal-ring area of the sheet are substantially identical to those described for the previous embodiments and will not be described in detail again.

[0186] Referring now also to FIG. 13a, there is illustrated a partial cross-sectional view to the edge of the sheet 304. In this example, the step of preparing a frame attachment area 1200 on the sheet 304 comprises roughening the frame attachment area by roughening and/or grinding the surface from its original level (shown in broken line) to produce a recessed area 1302. After the frame attachment area 1200 has been prepared, metal layers are deposited into the frame attachment area of the sheet using cold gas dynamic spray deposition. In FIG. 12b, an initial metal layer 1202 has been applied into the frame attachment area 1200 using cold gas dynamic spray deposition.

[0187] Referring now also to FIG. 13b, the cold gas dynamic spray nozzle 1304 is shown depositing a stream of metal particles 1306 onto the frame attachment area 1200. The initial layer 1202 has now been overlaid with a secondary layer 1204 and the spray nozzle 1304 is shown as it begins to deposit the final Kovar alloy layer 1206.

[0188] Referring now to FIG. 12c, the completed cover assembly 1210 is illustrated including the integral frame/heat spreader 1212, which has been built up from layer 1206 to a predetermined height, denoted by reference numeral 1308, above the finished surface of the sheet. In a preferred embodiment, the predetermined height 1308 of the built-up metal frame above the frame attachment area 1200 is within the range from about 5% to about 100% of the thickness denoted by reference numeral 1310 of the sheet 304 beneath the frame attachment area. In the embodiment shown, the step of depositing metal using cold gas dynamic spray included depositing a layer of Kovar alloy onto the sheet to fabricate the built-up frame/heat spreader 1212. The use of cold gas dynamic spray deposition allows a tremendous range of thickness for this Kovar alloy layer, which thickness may be within the range from about 2.54 microns to about 12,700 microns. It will, of course, be appreciated that the frame/heat spreader 1212 may be fabricated through the deposition of materials other than Kovar alloy, depending upon the characteristics of the transparent sheet 304 and of the package base 104, especially their respective CTEs.

[0189] The following examples, not to be considered limiting, are provided to illustrate the details of the metallic layers, denoted collectively by reference numeral 1207 for forming a frame/heat spreader compatible with hard glass transparent sheets and Kovar alloy or ceramic package bases.

EXAMPLE 91

[0190]

Layers	Metal	Deposition	Min. (microns)	Max. (microns)
1	Al	cold gas spray	2.54	127
2	Cu	cold gas spray	2.54	127
3	Ni	cold gas spray	2.54	127
4	Kovar Alloy	cold gas spray	127	12,700

EXAMPLE 92

[0191]

Layers	Metal	Deposition	Min. (microns)	Max. (microns)
1	Al	cold gas spray	2.54	127
2	Ni	cold gas spray	2.54	127
3	Kovar Alloy	cold gas spray	127	12,700

EXAMPLE 93

[0192]

Layers	Metal	Deposition	Min. (microns)	Max. (microns)
1	Al	cold gas spray	2.54	127
2	Kovar Alloy	cold gas spray	127	12,700

EXAMPLE 94

[0193]

Layers	Metal	Deposition	Min. (microns)	Max. (microns)
1	Kovar Alloy	cold gas spray	127	12,700

EXAMPLE 95

[0194]

Layers	Metal	Deposition	Min. (microns)	Max. (microns)
1	Zn	cold gas spray	2.54	127
2	Ni	cold gas spray	2.54	127
3	Kovar alloy	cold gas spray	127	12,700

EXAMPLE 96

[0195]

Layers	Metal	Deposition	Min. (microns)	Max. (microns)
1	Zn	cold gas spray	2.54	127
2	Kovar alloy	cold gas spray	127	12,700

EXAMPLE 97

[0196]

Layers	Metal	Deposition	Min. (microns)	Max. (microns)
1	Cr	cold gas spray	2.54	127
2	Ni	cold gas spray	2.54	127
3	Kovar alloy	cold gas spray	127	12,700

EXAMPLE 98

[0197]

Layers	Metal	Deposition	Min. (microns)	Max. (microns)
1	Cr	cold gas spray	2.54	127
2	Kovar alloy	cold gas spray	127	12,700

EXAMPLE 99

[0198]

Layers	Metal	Deposition	Min. (microns)	Max. (microns)
1	Al	cold gas spray	2.54	127
2	Zn	cold gas spray	2.54	127
3	Ni	cold gas spray	2.54	127
4	Kovar Alloy	cold gas spray	127	12,700

EXAMPLE 100

[0199]

Layers	Metal	Deposition	Min. (microns)	Max. (microns)
1	Ni	cold gas spray	2.54	127
2	Kovar Alloy	cold gas spray	127	12,700

EXAMPLE 101

[0200]

Layers	Metal	Deposition	Min. (microns)	Max. (microns)
1	Sn or Sn—Bi	cold gas spray	2.54	127
2	Zn	cold gas spray	2.54	127
3	Ni	cold gas spray	2.54	127
4	Kovar Alloy	cold gas spray	127	12,700

EXAMPLE 102

[0201]

Layers	Metal	Deposition	Min. (microns)	Max. (microns)
1	Sn or Sn—Bi	cold gas spray	2.54	127
2	Ni	cold gas spray	2.54	127
3	Kovar Alloy	cold gas spray	127	12,700

[0202] By way of further examples, not to be considered limiting, the following combinations are preferred for the metallic layers 1207 for forming a frame/heat spreader compatible with hard glass transparent sheets and Kovar alloy or ceramic package bases.

EXAMPLE 103

[0203]

Layers	Metal	Deposition	Min. (microns)	Max. (microns)
1	Al	cold gas spray	12.7	76.2
2	Cu	cold gas spray	12.7	76.2
3	Ni	cold gas spray	12.7	76.2
4	Kovar Alloy	cold gas spray	635	2,540

EXAMPLE 104

[0204]

Layers	Metal	Deposition	Min. (microns)	Max. (microns)
1	Al	cold gas spray	12.7	76.2
2	Ni	cold gas spray	12.7	76.2
3	Kovar Alloy	cold gas spray	635	2,540

EXAMPLE 105

[0205]

Layers	Metal	Deposition	Min. (microns)	Max. (microns)
1	Al	cold gas spray	12.7	76.2
2	Kovar Alloy	cold gas spray	635	2,540

EXAMPLE 106

[0206]

Layers	Metal	Deposition	Min. (microns)	Max. (microns)
1	Kovar Alloy	cold gas spray	635	2,540

EXAMPLE 107

[0207]

Layers	Metal	Deposition	Min. (microns)	Max. (microns)
1	Zn	cold gas spray	12.7	76.2
2	Ni	cold gas spray	12.7	76.2
3	Kovar alloy	cold gas spray	635	2,540

EXAMPLE 108

[0208]

Layers	Metal	Deposition	Min. (microns)	Max. (microns)
1	Zn	cold gas spray	12.7	76.2
2	Kovar alloy	cold gas spray	635	2,540

EXAMPLE 109

[0209]

Layers	Metal	Deposition	Min. (microns)	Max. (microns)
1	Cr	cold gas spray	12.7	76.2
2	Ni	cold gas spray	12.7	76.2
3	Kovar alloy	cold gas spray	635	2,540

EXAMPLE 110

[0210]

Layers	Metal	Deposition	Min. (microns)	Max. (microns)
1	Cr	cold gas spray	12.7	76.2
2	Kovar alloy	cold gas spray	635	2,540

EXAMPLE 111

[0211]

Layers	Metal	Deposition	Min. (microns)	Max. (microns)
1	Al	cold gas spray	12.7	76.2
2	Zn	cold gas spray	12.7	76.2
3	Ni	cold gas spray	12.7	76.2
4	Kovar Alloy	cold gas spray	635	2,540

EXAMPLE 112

[0212]

Layers	Metal	Deposition	Min. (microns)	Max. (microns)
1	Ni	cold gas spray	12.7	76.2
2	Kovar Alloy	cold gas spray	635	2,540

EXAMPLE 113

[0213]

Layers	Metal	Deposition	Min. (microns)	Max. (microns)
1	Sn or Sn—Bi	cold gas spray	12.7	76.2
2	Zn	cold gas spray	12.7	76.2
3	Ni	cold gas spray	12.7	76.2
4	Kovar Alloy	cold gas spray	635	2,540

EXAMPLE 114

[0214]

Layers	Metal	Deposition	Min. (microns)	Max. (microns)
1	Sn or Sn—Bi	cold gas spray	12.7	76.2
2	Ni	cold gas spray	12.7	76.2
3	Kovar Alloy	cold gas spray	635	2,540

[0215] After the deposition of the metal layers using the cold gas dynamic spray deposition, it may be necessary to grind or shape the top surface of the built-up frame **1212** to a predetermined flatness before performing additional steps to ensure that a good contact will be made in later bonding. Another process which may be used, either alone or in combination with shaping the top surface of the built-up frame, is the depositing of additional metal layers onto the built-up frame/heat spreader **1212** using solution bath plating. The most common reason for such plated layers is to promote a good bonding when the frame/heat spreader is adjoined to the package base **104**. In a preferred embodiment, the additional metallic layers applied to the built-up frame **1212** include a layer of nickel directly over the cold gas dynamic spray deposited metal having a thickness within the range of about 0.002 microns to about 25 microns and then solution bath plating a layer of gold over the nickel layer until the gold layer has a thickness within the range from about 0.0508 microns to about 0.508 microns.

[0216] Referring now to FIG. **14**, there is illustrated a block diagram of the alternative embodiment utilizing cold gas dynamic spray deposition. It will be appreciated that, unless specifically noted otherwise, the initial steps of obtaining a transparent sheet having finished surfaces, applying surface treatments to the sheet, cleaning, roughening or otherwise preparing the frame attachment area of the sheet are substantially identical to those described for the previous embodiments and will not be described in detail again. For example, block **1402** of FIG. **14** represents the step of obtaining a sheet of transparent material having finished surfaces and corresponds directly with block **902**, and with the description of suitable transparent materials. Similarly, except as noted, blocks **1404**, **1406** and **1408** of FIG. **14** correspond directly with blocks **904**, **906** and **908**, respectively, of FIG. **9** and with the previous descriptions of the steps and sub-steps provided herein. Thus, it will be understood that all of the options described for performing the various steps and sub-steps represented by the blocks **902-908** in the previous (i.e., prefabricated frame) embodiments are applicable to the blocks **1402-1408** in the current (i.e., cold spray) embodiment.

[0217] The next step of the process is to use cold gas dynamic spray deposition to deposit frame/heat spreader

metal onto any previously deposited metal layers in the frame attachment area **1200**. This step is represented by block **1410**. As previously described in connection with FIGS. **13b** and **13c**, the high velocity particles **1306** from the gas nozzle **1304** form a new layer on the previous metallic layers, and by directing the cold spray jet across the frame attachment area **1200** repeatedly, the new material can become a continuous metallic layer around the entire periphery of the frame attachment area, i.e., it will circumscribe the window portion **312** of the transparent sheet **304**. Where the material of the package base **104** (to which the cover assembly **1210** will eventually be joined) is Kovar alloy or appropriately metallized alumina, Kovar alloy is preferred for the material **1206** to be cold sprayed to form the integral frame. In other cases, a heat spreader material must be selected which has a CTE that is closely matched to the CTE of the package base **104**. Of course, that material must also be compatible with the cold gas dynamic spray process.

[0218] The cold spraying of the powdered heat spreader material is continued until the new layer **1206** reaches the thickness required to serve as a heat spreader/integral frame. This would represent the end of the process represented by block **1410**. It will be appreciated that there are flatness requirements for the sealing surface at the top of the heat spreader (which is actually on the bottom surface **316** of the sheet). If these flatness requirements are not met via the application of the heat spreader material by the cold spray process, it will be necessary to flatten the sealing surface at the next step of the process. This step is represented by block **1412** in FIG. **14**. There are a number of options for achieving the required surface flatness. First, it is possible to remove surface material from the heat spreader to achieve the required flatness. This may be accomplished by conventional surface grinding, by other traditional mechanical means, or it may be accomplished by the laser removal of high spots. Where material removal is used, care must be taken to avoid damaging the finished window surfaces **314** and **316** during the material removal operations. Special fixturing and/or masking of the window portion **312** may be required. Alternatively, if the cold spray deposited heat spreader **1919** is ductile enough, the surface may be flattened using a press operation, i.e., pressing the frame against a flat pattern. This would reduce the handling precautions as compared to using a surface grinder or laser operations.

[0219] Finally, as previously described, in some embodiments additional metal layers are plated onto the integral frame/heat spreader. These operations, such as solution bath plating layers of nickel and gold onto a Kovar alloy frame, are represented by block **1414** in FIG. **14**.

[0220] Referring now to FIGS. **15a** and **15b**, there is illustrated a method for manufacturing multiple cover assemblies simultaneously in accordance with another embodiment of the current invention. Shown in FIG. **15a** is an exploded view of a multi-unit assembly which can be subdivided after fabrication to produce individual cover assemblies. The multi-unit assembly **1500** includes a frame **1502** and a sheet **1504** of a transparent material. The frame **1502** has sidewalls **1506** defining a plurality of frame apertures **1508** there through. Each frame aperture **1508** is circumscribed by a continuous sidewall section having a frame seal-ring area **1510** (denoted by cross-hatching). Each frame seal-ring area **1510** has a metallic surface, which may result from the inherent material of the frame **1502** or it may result from metal layers which have been applied to the surface of the frame. In some

embodiments, the frame **1502** includes reduced cross-sectional thickness areas **1509** formed on the frame sidewalls **1506** between adjacent frame apertures **1508**. FIG. **15b** shows the bottom side of the frame **1502**, to better illustrate the reduced cross-sectional thickness areas **1509** formed between each aperture **1508**. Also illustrated is the base seal-ring area **1520** (denoted by cross-hatching) which surrounds each aperture **1508** to allow joining to the package bases **104**.

[0221] Except for the details just described, the multiple-aperture frame **1502** of this embodiment shares material, fabrication and design details with the single aperture frame **302** previously described. In this regard, a preferred embodiment of the frame **1502** is primarily formed of Kovar alloy or similar materials and more preferably, will have a Kovar alloy core with a surface layer of gold overlaying an intermediate layer of nickel as previously described.

[0222] The transparent sheet **1504** for the multi-unit assembly can be formed from any type of transparent material as previously discussed for sheet **304**. In this embodiment, however, the sheet **1504** has a plurality of window portions **1512** defined thereupon, with each window portion having finished top and bottom surface **1514** and **1516**, respectively. A plurality of sheet seal-ring areas **1518** are denoted by cross-hatching surrounding each window portion in FIG. **15a**. With respect to the material of the sheet **1504**, with respect to the finished configuration of the top and bottom surfaces **1514** and **1516**, respectively, of each window portion **1512**, with respect to surface treatments, and/or coatings, the sheet **1504** is substantially identical to the single window portion sheet **304** previously discussed.

[0223] The next step of the process of manufacturing the multi-unit assembly **1500** is to prepare the sheet seal-ring areas **1518** for metallization. As noted earlier, each sheet seal-ring area **1518** circumscribes a window portion of the sheet **1504**. The sheet seal-ring areas **1508** typically have a configuration which closely matches the configuration of the frame seal-ring areas **1510** to which they will eventually be joined. It will be appreciated, however, that in some cases other considerations will affect the configuration of the frame grid, e.g. when electrical resistance heating is used to produce bonding, then the seal-ring areas **1518** must be connected to form the appropriate circuits. The steps of preparing the sheet seal-ring areas **1518** for metallization is substantially identical to the steps and options presented during discussion of preparing the frame seal-ring area **310** on the single aperture frame **302**. Thus, at a minimum, preparing the sheet seal-ring area **1518** involves a thorough (e.g., plasma) cleaning to remove any contaminants from the surfaces and typically also involves roughening the seal-ring area by chemical etching, laser ablating, mechanical grinding or sandblasting this area.

[0224] The step of metallizing the prepared sheet seal-ring areas **1510** of the sheet **1502** are substantially identical to the steps described for metallizing the frame seal-ring area **310** on the single aperture frame **302**. For example, the metal layers shown in Examples 1 through 8 can be used in connection with thermal compression bonding, the metal layers of Examples 9 through 20 can be used for soldering where the solder material is plated onto the sheet as a final metallic layer, the metal layer configurations of Examples 21 through 32 can be used in connection with soldering in combination with a separate gold-tin of solder preform and also for soldering in connection with solders deposited or formed using inkjet technology.

[0225] The next step of the process is to position the frame 1502 against the sheet 1504 (it being understood that solder preforms or solder layers would be interposed between the frame and the sheet) such that each of the window portions 1512 overlays one of the frame apertures 1508, and that for each such window portion/frame aperture combination, at least a portion of the associated frame seal-ring area 1510 and at least a portion of the associated sheet seal-ring area 1518 contact one another along a continuous junction region that circumscribes the associated window portion. This operation is generally analogous to the steps of positioning the frame against the sheet in the single aperture embodiment previously described.

[0226] Referring now to FIG. 16a, there is illustrated the positioning of a multi-window sheet 1504 (in this case having window portions 1512 with contoured surfaces) against a multi-aperture frame 1502 using compliant tooling in accordance with another embodiment. The compliant tooling includes a compliant element 1650 and upper and lower support plates 1652, 1654, respectively. The support plates 1652 and 1654 receive compressive force, denoted by arrows 1656, at discrete locations from tooling fixtures (not shown). The compliant member 1650 is positioned between one of the support plates and the cover assembly pre-fab (i.e., frame 1502 and sheet 1504). The compliant member 1650 yields elastically when a force is applied, and therefore can conform to irregular surfaces (such as the sheet 1504) while at the same time applying a distributed force against the irregular surface to insure that the required contact pressure is achieved all along the frame/sheet junction. Such compliant tooling can also be used to press a sheet or frame against the other member when the two members are not completely flat, taking advantage of the inherent flexibility (even if small) present in all materials. In the illustrated example, the compliant member 1650 is formed from a solid block of an elastomer material, e.g., rubber, however in other embodiments the compliant member may also be fabricated from discrete elements, e.g., springs.

[0227] The next step of the process is heating all of the junction regions until a metal-to-metal joint is formed between the frame 1502 and the sheet 1504 all along each junction region, thus creating the multi-unit assembly 1500 having a hermetic frame/sheet seal circumscribing each window portion 1512. It will be appreciated that any of the heating technologies previously described for joining the single aperture frame 302 to the single sheet 304 are applicable to joining the multi-aperture frame 1502 to the corresponding multi-window sheet 1504.

[0228] Referring now to FIG. 16b, the final step of the current process is to divide the multi-unit assembly 1500 along each junction region that is common between two window portions 1512 taking care to preserve and maintain the hermetic seal circumscribing each window portion. A plurality of individual cover assemblies are thereby produced. FIG. 16b, illustrates a side view of a multi-unit assembly 1500 following the hermetic bonding of the sheet 1504 to the frame 1502. Where the frame 1502 includes reduced cross-sectional thickness areas 1509, the step of dividing the multi-unit assembly may include scoring the frame along the back side of the reduced cross-sectional thickness area at the position indicated by arrow 1602, preferably breaking through or substantially weakening the remaining frame material below area 1509, and also simultaneously scoring the sheet 1504 along a line vertically adjacent to area 1509, i.e., at the point

indicated by arrow 1604, followed by flexing the assembly 1500, e.g., in the direction indicated by arrows 1606 such that a fracture will propagate away from the score along line 1608, thereby separating the assembly into two pieces. This procedure can be repeated along each area of reduced cross-sectional thickness 1509 until the multi-unit assembly 1500 has been completely subdivided into single aperture cover assemblies that are substantially identical to those produced by the earlier method described herein. In other embodiments, instead of using the score-and-break method, the cover assemblies may be cut apart, preferably from the frame side along the path indicated by arrow 1602 (i.e., between the window portions 1512), using mechanical cutting, laser, water jet or other parting technology.

[0229] Referring now to FIGS. 17a and 17b, there is illustrated yet another method for simultaneously manufacturing multiple cover assemblies. This method expands upon the cold gas dynamic spray technique used to build an integral frame/heat spreader directly upon the transparent sheet material as previously illustrated in connection with FIGS. 12a through 12c and FIGS. 13a through 13c. As shown in FIG. 17a, the process starts with a sheet of nonmetallic transparent material 1704 having a plurality of window portions 1712 defined thereupon, each window portion having finished top and bottom surfaces 1714 and 1716, respectively. The properties and characteristics of the transparent sheet 1704 are substantially identical to those in the embodiments previously discussed. The next step of the process involves preparing a plurality of frame attachment areas 1720 (denoted by the path of the broken line surrounding each window portion 1712), each frame attachment area 1720 circumscribing one of the window portions 1712. As in previous embodiments, the step of preparing the frame attachment areas may comprise cleaning, roughening, grinding or otherwise modifying the frame attachment areas in preparation for metallization.

[0230] The next step in this process is metallizing the prepared frame attachment areas on the sheet, i.e., this metallization may be performed using a cold gas dynamic spray technology or where the layers are relatively thin, using a CVD, physical vapor deposition or other conventional metal deposition techniques. It will be appreciated that the primary purpose of this step is to apply metal layers necessary to obtain good adhesion to the transparent sheet 1704 and/or to meet the metallurgical requirements for corrosion prevention, etc.

[0231] Referring now to FIG. 17b, the next step of the process is depositing metal onto the prepared/metallized frame attachment areas of the sheet 1704 using cold gas dynamic spray deposition techniques until a built-up metal frame 1722 is formed upon the sheet having a seal-ring area 1726 that is a predetermined vertical thickness above the frame attachment areas, thus creating a multi-unit assembly having an inherent hermetic seal between the frame 1722 and the sheet 1704 circumscribing each window portion 1712. In some embodiments, reduced cross-sectional thickness areas 1724 are formed by selectively depositing the metal during the cold spray deposition. In other embodiments, the reduced cross-sectional area sections 1724 may be formed following deposition of the frame/heat spreader 1722 through the use of grinding, cutting or other mechanical techniques such as laser ablation and water jet.

[0232] The next step of the process which, while not required is strongly preferred, is to flatten, if necessary, the seal-ring area 1726 of the sprayed-on frame 1722 to meet the

flatness requirements for joining it to the package base **104**. This flattening can be accomplished by mechanical means, e.g., grinding, lapping, polishing, etc., or by other techniques such as laser ablation.

[0233] The next step of the process, which, while not required, is strongly preferred, is to add additional metallic layers, e.g., a nickel layer and preferably also a gold layer, to the seal-ring area **1726** of the sprayed-on frame **1722** to facilitate welding the cover assembly to the package base **104**. These metallic layers are preferably added using a solution bath plating process, e.g., solution bath plating, although other techniques may be used.

[0234] The next step of the process is dividing the multi-unit assembly **1700** along each frame wall section common between two window portions **1712** while, at the same time, preserving and maintaining the hermetic seal circumscribing each window portion. After dividing the multi-unit **1700**, a plurality of single aperture cover assemblies **1728** (shown in broken line) will be produced, each one being substantially identical to the single aperture cover assemblies produced using the method described in FIGS. **12a** through **12c** and FIGS. **13a** through **13c**. All of the options, characteristics and techniques described for use in the single unit cover assembly produced using cold gas dynamic spray technology are applicable to this embodiment. It will be appreciated that certain operations for example, the flattening of the frame and the plating of the frame with additional metallic layers, may be performed on the multi-unit assembly **1700**, prior to separation of the individual units, or on the individual units after separation.

[0235] As previously described, heating the junction region between the metallized seal-ring area of the transparent sheet and the seal-ring area of the frame is required for forming the hermetic seal there between. Also as previously described, this heating may be accomplished using a furnace, oven, or various electrical heating techniques, including electrical resistance heating (ERH). Referring now to FIGS. **18a-18c**, there is illustrated methods of utilizing electric resistance heating to manufacture multiple cover assemblies simultaneously.

[0236] Referring first to FIG. **18a**, there is illustrated a transparent sheet **1804** having a plurality of seal-ring areas **1818** laid out in a rectangular arrangement around a plurality of window portions **1812**. These seal-ring areas **1818** have been first prepared, and then metallized with one or more metal or metal alloy layers, as previously described herein. The transparent sheet **1804** further includes an electrode portion **1830** which has been metallized, but does not circumscribe any window portions **1812**. This electrode portion is electrically connected to the metallized seal-ring areas **1818** of the sheet. One or more electrode pads **1832** may be provided on the electrode portion **1830** to receive electrical energy from electrodes during the subsequent ERH procedure.

[0237] Referring now to FIG. **18b**, there is illustrated a frame **1802** having a plurality of sidewalls **1806** laid out in a rectangular arrangement around a plurality of frame apertures **1808**. The apertures **1808** are disposed so as to correspond with the positions of the window portions **1812** of the sheet **1804**, and the sidewalls **1806** are disposed so that frame seal-ring areas **1810** (located thereupon) correspond with the positions of the sheet seal-ring areas **1818** of the sheet. The frame is metallic or metallized in order to facilitate joining as previously described herein. The frame **1802** further includes

an electrode portion **1834** that does not circumscribe any frame apertures **1808**. This frame electrode portion **1834** is positioned so as not to correspond to the position of the sheet electrode portion **1830**, and preferably is disposed on an opposing side of the sheet-window/frame-grid assembly (i.e., when the sheet is assembled against the frame). The frame electrode portion **1834** is electrically connected to the metallized frame seal-ring areas **1810**. One or more electrode pads **1836** may be provided on the electrode portion **1834** to receive electrical energy from electrodes during the subsequent ERH procedure.

[0238] Referring now to FIG. **18c**, the sheet **1804** is shown positioned against the frame **1802** in preparation for heating to produce the hermetic seal there between. If applicable, solder or a solder preform has been positioned there between as previously described. It will be appreciated that when the transparent sheet **1804** is brought against the frame **1802**, the metallized seal-ring areas **1818** on the lower surface of the sheet will be in electrical contact with the metallized seal-ring areas **1810** on the upper surface of the frame. However, the sheet electrode portion **1830** and the frame electrode portion **1834** will not be in direct contact with one another, but instead will be electrically connected only through the metallized seal-ring areas **1818** and **1810** to which they are, respectively, electrically connected. When an electrical potential is applied from electrode pads **1832** to electrode pads **1834** (denoted by the “+” and “-” symbols adjacent to the electrodes), electrical current flows through the junction region of the entire sheet-window/frame-grid assembly. This current flow produces electrical resistance heating (ERH) due to the resistance inherent in the metallic layers. In some embodiments, this electrical resistance heating may be sufficient, in and of itself, to result in TC bonding, soldering, or other hermetic seal formation between the sheet **1804** and the frame **1802** in order to form a multi-unit assembly. In other embodiments, however, electrical resistance heating may be combined with other heating forms such as furnace or oven pre-heating in order to supply the necessary heat required for bonding to form the multi-unit assembly.

[0239] After bonding the sheet **1804** to the frame **1802** to form the multi-unit assembly, the sheet electrode portion **1830** and the frame electrode portion **1834** can be cut away and discarded, having served their function of providing electrical access for external electrodes (or other electrical supply members) to the metallized seal-ring areas of the sheet and frame, respectively. The removal of these “sacrificial” electrode portions **1830** and **1834** may occur before or during the “dicing” process step, i.e., the separating of the multi-unit assembly into individual cover assemblies. It will be appreciated that any of the technologies previously described herein for separating a multi-unit assembly into individual cover assemblies can be used for the dicing step of separating a multi-unit assembly fabricated using ERH heating.

[0240] Where ERH is to be used for manufacturing multiple cover assemblies simultaneously, the configuration of the sheet-window/frame-grid array and/or the placement of the electrodes portions within the sheet-window/frame-grid array may be selected to modify the flow of current through the junction region during heating. The primary type of modification is to even the flow of current through the various portions of the sheet-window/frame-grid during heating to produce more even temperatures, i.e., to avoid “hot spots” or “cold spots.”

[0241] Referring now to FIGS. 19a-19f, there are illustrated various sheet-window/frame-grid configurations adapted for producing more even temperatures during ERH. In each of FIGS. 19a-19f, there is shown a sheet-window/frame-grid array 1900 comprising a prepared, metallized transparent sheet 1904 overlying a prepared, metallic/metallized frame 1902. The window portions of the sheet 1904 directly overlie the frame apertures of the frame 1902, and the metallized seal-ring areas of the sheet directly overlie the seal-ring areas of the frame (it will be appreciated that metallized portions of the sheet 1904 and the frame 1902 appear coincident in these figures). Metallized electrode portions formed on the transparent sheet 1904 are denoted by reference letters A, B, C and D. These electrode portions A, B, C and D are electrically connected to the adjoining sheet seal-ring areas of the sheet, but are electrically insulated from one another by non-metallized areas 1906 of the sheet. An external electrode is applied to the top of the metallic/metallized frame (on the side opposite from the sheet) across the area denoted by reference letter E. For bonding or soldering, electrical power is applied at the electrodes, e.g., one line to electrodes A, B, C and D simultaneously, and the other line to electrode E, or alternatively, one line in sequence to each of electrode A, B, C and D, and the other line to electrode E. It will be appreciated that many other combinations of electrode powering are within the scope of the invention.

[0242] Referring to FIG. 19f, this embodiment illustrates a sheet-window/frame-grid 1900 having a "shingle" configuration, i.e., where the seal-ring areas between the window portions/frame apertures do not form continuous straight lines across the assembly array. Shingle-arrangement frame assemblies are more labor-intensive to separate using scribe-and-break or cutting procedures. Separating such assemblies requires that each row first be separated from the overall grid, and then that individual cover assemblies be separated from the row by separate scribe-and-break or cutting operations. Nevertheless, use of shingle-arrangement assemblies may have benefits relating to heating using ERH techniques.

[0243] While the invention has been shown or described in a variety of its forms, it should be apparent to those skilled in the art that it is not limited to these embodiments, but is susceptible to various changes without departing from the scope of the invention.

1. A method for manufacturing a cover assembly that can be hermetically attached to a base to form a unit having a hermetically sealed interior cavity, the cover assembly including a transparent window portion and a frame, the method comprising the following steps:

providing a frame of gas-impervious metallic material having a continuous sidewall defining a frame aperture therethrough;

providing a sheet of a transparent material having a window portion defined thereupon;

positioning the frame against the sheet such that at least a portion of the frame and at least a portion of the sheet contact one another along a junction region that circumscribes the portion of the window portion that is aligned with the frame aperture;

pressing the frame against the sheet with sufficient force to produce a predetermined contact pressure between contacting portions of the frame and the sheet;

heating the contacting portions of the frame and sheet to produce a predetermined temperature therein; and

maintaining the predetermined contact pressure and the predetermined temperature until a material originally in one of the frame and the sheet diffuses into the other of the frame and the sheet creating a hermetically sealed diffusion bond between the frame and the sheet.

2. A method in accordance with claim 1, wherein the step of pressing the frame is performed before the step of heating the contacting portions.

3. A method in accordance with claim 1, wherein the step of heating the contacting portions is performed before the step of pressing the frame.

4. A method in accordance with claim 1, wherein the steps of pressing the frame and of heating the contacting portions are performed simultaneously.

5. A method in accordance with claim 1, wherein the transparent material of the sheet is a glass.

6. A cover assembly that can be hermetically sealed to a base to form a hermetically sealed unit having an interior cavity, the cover assembly including:

a frame of gas-impervious material having a continuous sidewall defining a frame aperture therethrough;

a sheet of a transparent material having a window portion defined thereupon, the sheet being hermetically bonded to the frame by positioning the frame against the sheet such that at least a portion of the frame and at least a portion of the sheet contact one another along a junction region that circumscribes the portion of the window portion that is aligned with the frame aperture; pressing the frame against the sheet with sufficient force to produce a predetermined contact pressure between contacting portions of the frame and the sheet; heating the contacting portions of the frame and sheet to produce a predetermined temperature therein; and maintaining the predetermined contact pressure and the predetermined temperature until a hermetically sealed diffusion bond is formed between the frame and the sheet; and

wherein the cover assembly includes a region at the junction of the frame and the sheet exhibiting diffusion of a material originally in one of the frame and the sheet into the other of the frame and the sheet.

7. A cover assembly in accordance with claim 6, wherein the pressing of the frame is performed before the heating of the contacting portions.

8. A cover assembly in accordance with claim 6, wherein the heating of the contacting portions is performed before the pressing of the frame.

9. A cover assembly in accordance with claim 6, wherein the pressing of the frame and the heating of the contacting portions are performed simultaneously.

10. A cover assembly in accordance with claim 6, wherein the transparent material of the sheet is a glass.

11. A cover assembly in accordance with claim 6, wherein during the heating of the contacting portions, the temperature of the window portion of the sheet remains below the glass transition temperature ($T_{sub.G}$) of the transparent material.

12. A hermetically sealed unit including:

a base;

a device mounted on the base; and

a cover assembly hermetically sealed to the base so as to encapsulate the device in a hermetically sealed cavity formed therebetween, the cover assembly including a frame of gas-impervious material having a continuous sidewall defining a frame aperture therethrough, a sheet of a transparent material having a window portion

defined thereupon, the sheet being hermetically bonded to the frame by positioning the frame against the sheet such that at least a portion of the frame and at least a portion of the sheet contact one another along a junction region that circumscribes the portion of the window portion that is aligned with the frame aperture, pressing the frame against the sheet with sufficient force to produce a predetermined contact pressure between contacting portions of the frame and the sheet, heating the contacting portions of the frame and sheet to produce a predetermined temperature therein, and maintaining the predetermined contact pressure and the predetermined temperature until a hermetically sealed diffusion bond is formed between the frame and the sheet;
wherein the cover assembly includes a region at the junction of the frame and the sheet exhibiting diffusion of a material originally in one of the frame and the sheet into the other of the frame and the sheet.

13. A hermetically sealed unit in accordance with claim **12**, wherein the base is formed of a transparent material.

14. A hermetically sealed unit in accordance with claim **13**, wherein the device is an active device.

15. A hermetically sealed unit in accordance with claim **13**, wherein the device is a passive device.

16. A hermetically sealed unit in accordance with claim **15**, wherein the passive device has a height equal to the spacing between the sheet and the base.

17. A hermetically sealed unit in accordance with claim **15**, wherein the passive device affects the passage of visible light through the unit.

18. A hermetically sealed unit in accordance with claim **15**, wherein the passive device does not affect the passage of visible light through the unit.

* * * * *