

US 20090008243A1

(19) **United States**

(12) **Patent Application Publication**
Lin et al.

(10) **Pub. No.: US 2009/0008243 A1**

(43) **Pub. Date: Jan. 8, 2009**

(54) **CHLORINE GENERATOR**

(30) **Foreign Application Priority Data**

(75) Inventors: **Hua Hsiang Lin**, Fujian (CN);
Shen Wu Wong, Fujian (CN)

Feb. 6, 2006 (CN) 200620054822.9

Publication Classification

Correspondence Address:
YING CHEN
Chen Yoshimura LLP
255 S. GRAND AVE., # 215
LOS ANGELES, CA 90012 (US)

(51) **Int. Cl.**
C25D 17/00 (2006.01)

(52) **U.S. Cl.** **204/273**

(57) **ABSTRACT**

(73) Assignee: **INTEX RECREATION CORPORATION**, Long Beach, CA (US)

A chlorine generator includes a main water channel for connecting to a pool and a subsidiary water channel connected between two points on the main water channel. A feed valve, a brine tank, a pump and an electrolytic tank are located on the subsidiary water channel. Salt is added into the brine tank and dissolved in water drawn in from the main water channel, and the high concentration saline solution is pumped from the brine tank into the electrolytic tank where chlorine is generated from the saline. The chlorinated solution from the electrolytic tank is then mixed with the water in the main water channel. A stirring device is provided at the bottom of the brine tank to stir the water therein to facilitate the generation of high concentration saline solution. Salt is electrolyzed without being dissolved into the swimming pool directly, thereby reducing harmful effects to swimmers.

(21) Appl. No.: **12/278,276**

(22) PCT Filed: **Jan. 23, 2007**

(86) PCT No.: **PCT/US07/02095**

§ 371 (c)(1),
(2), (4) Date: **Aug. 4, 2008**

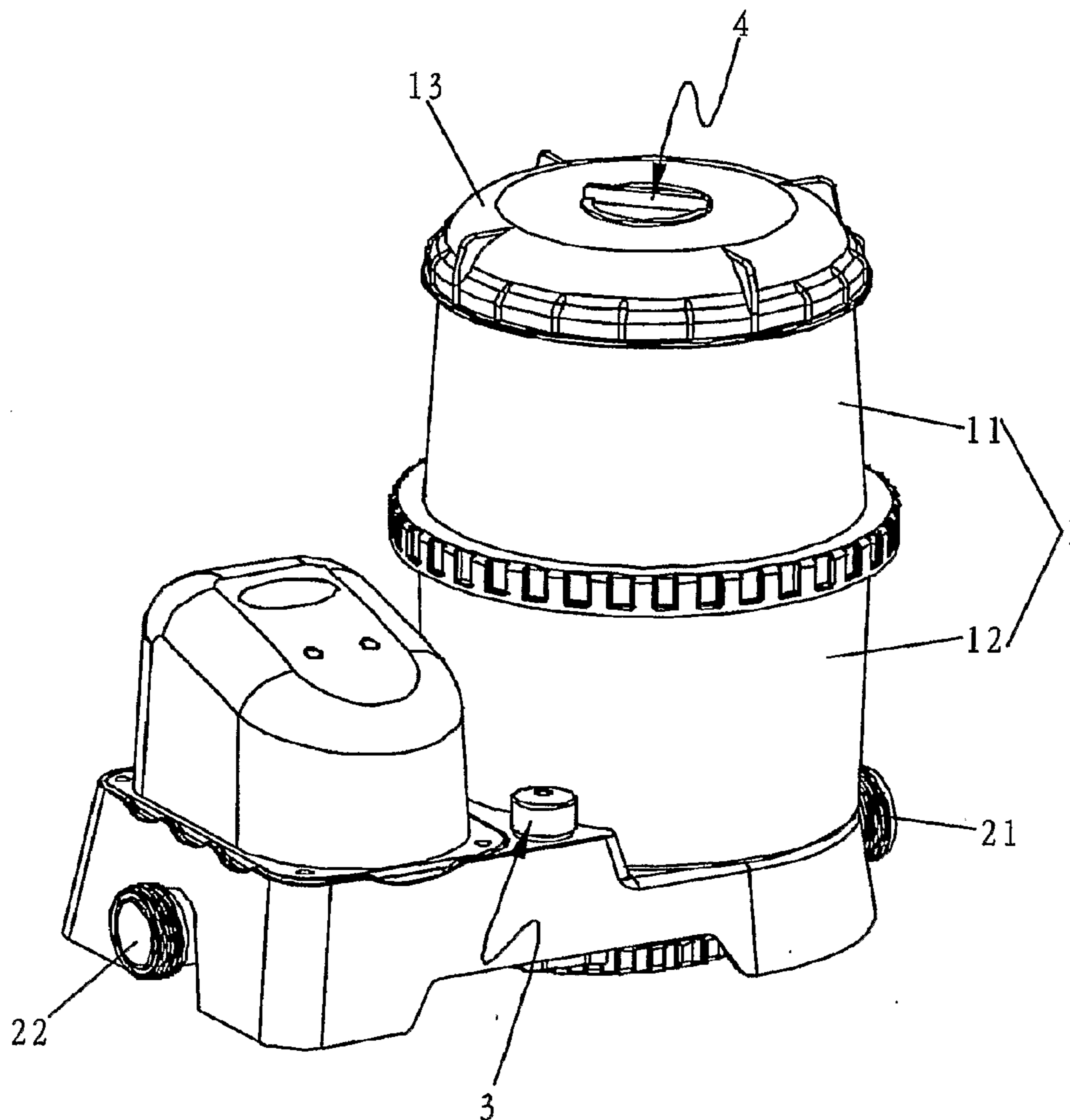

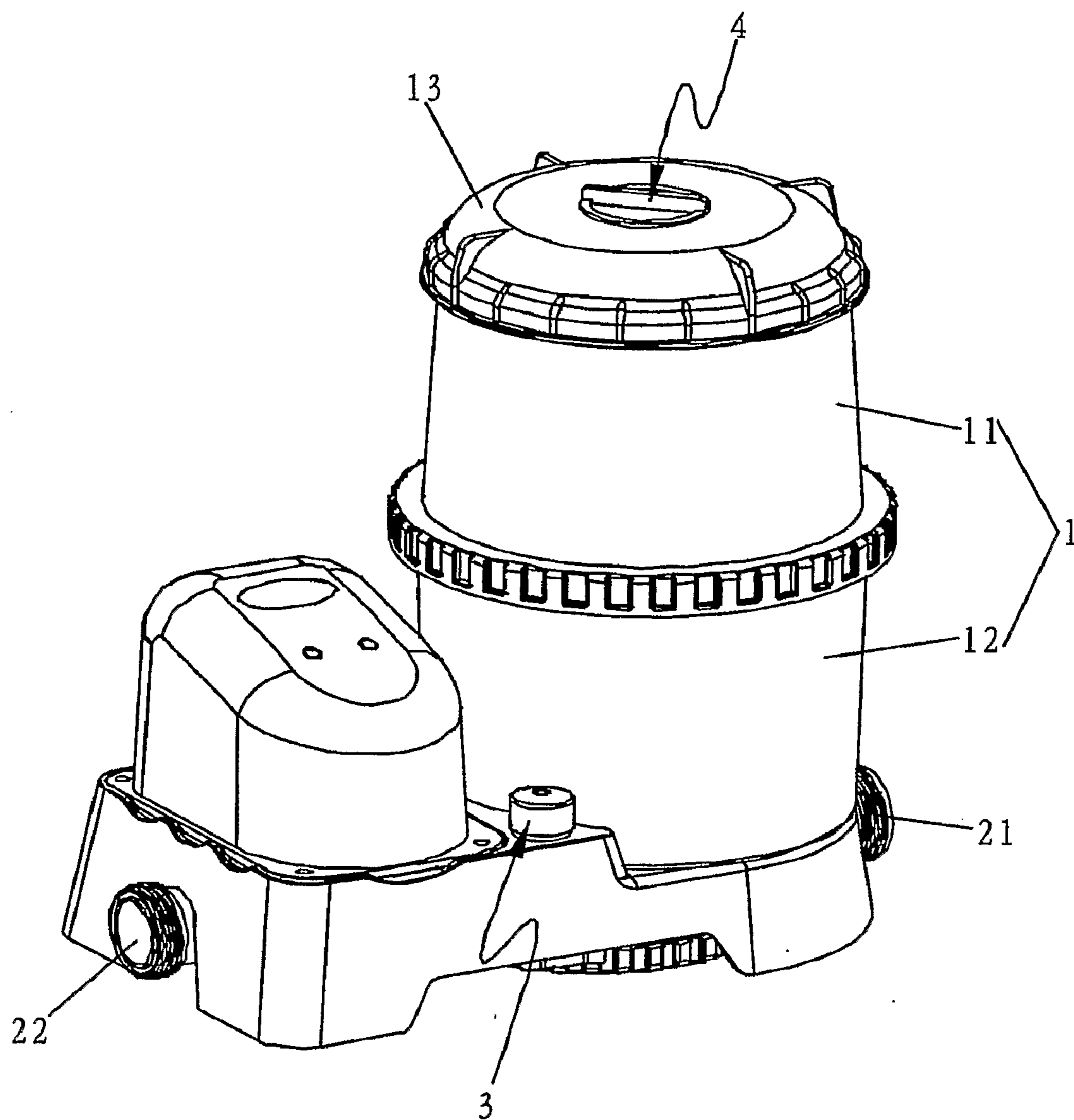

FIG. 1

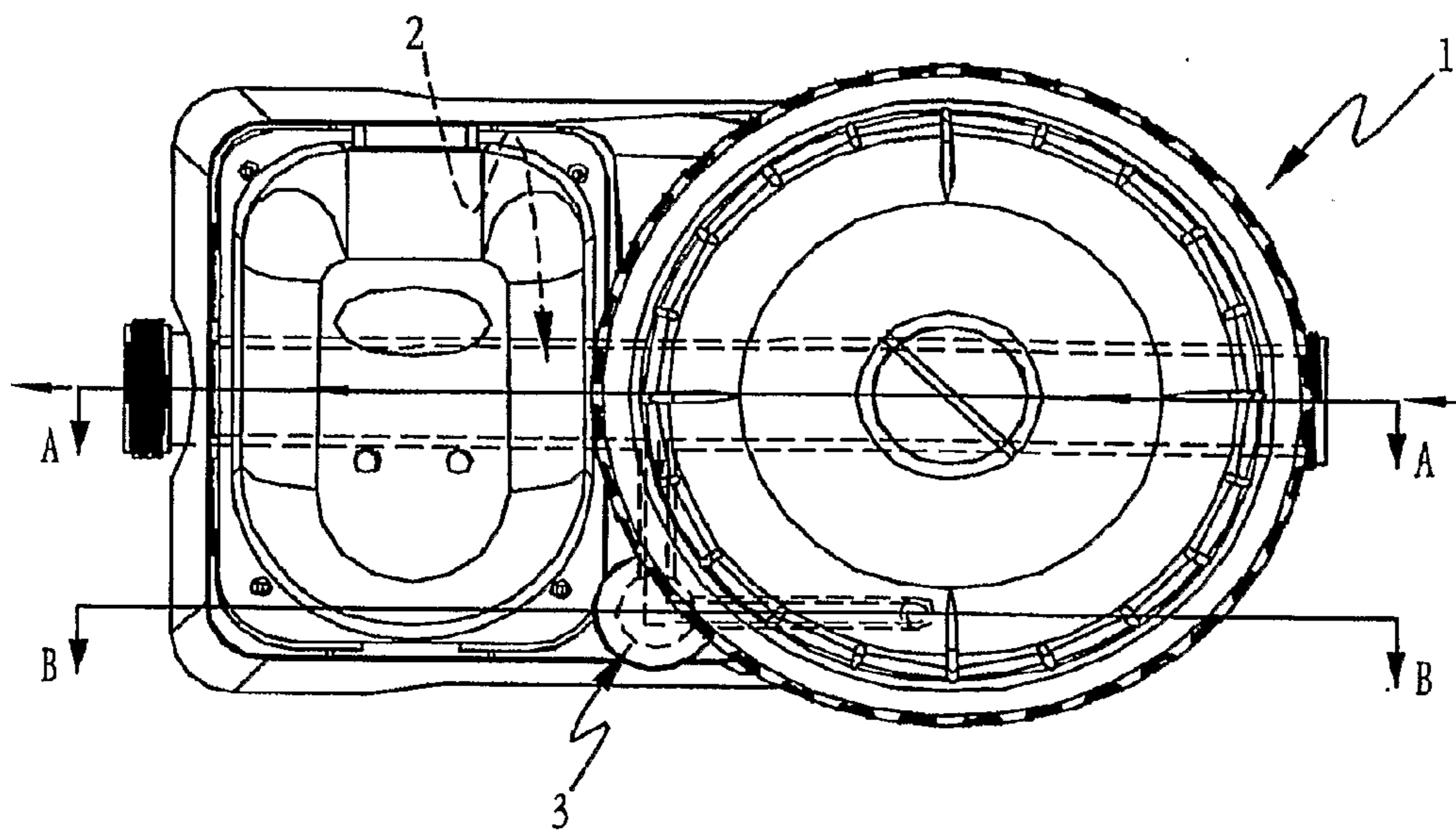

FIG. 2

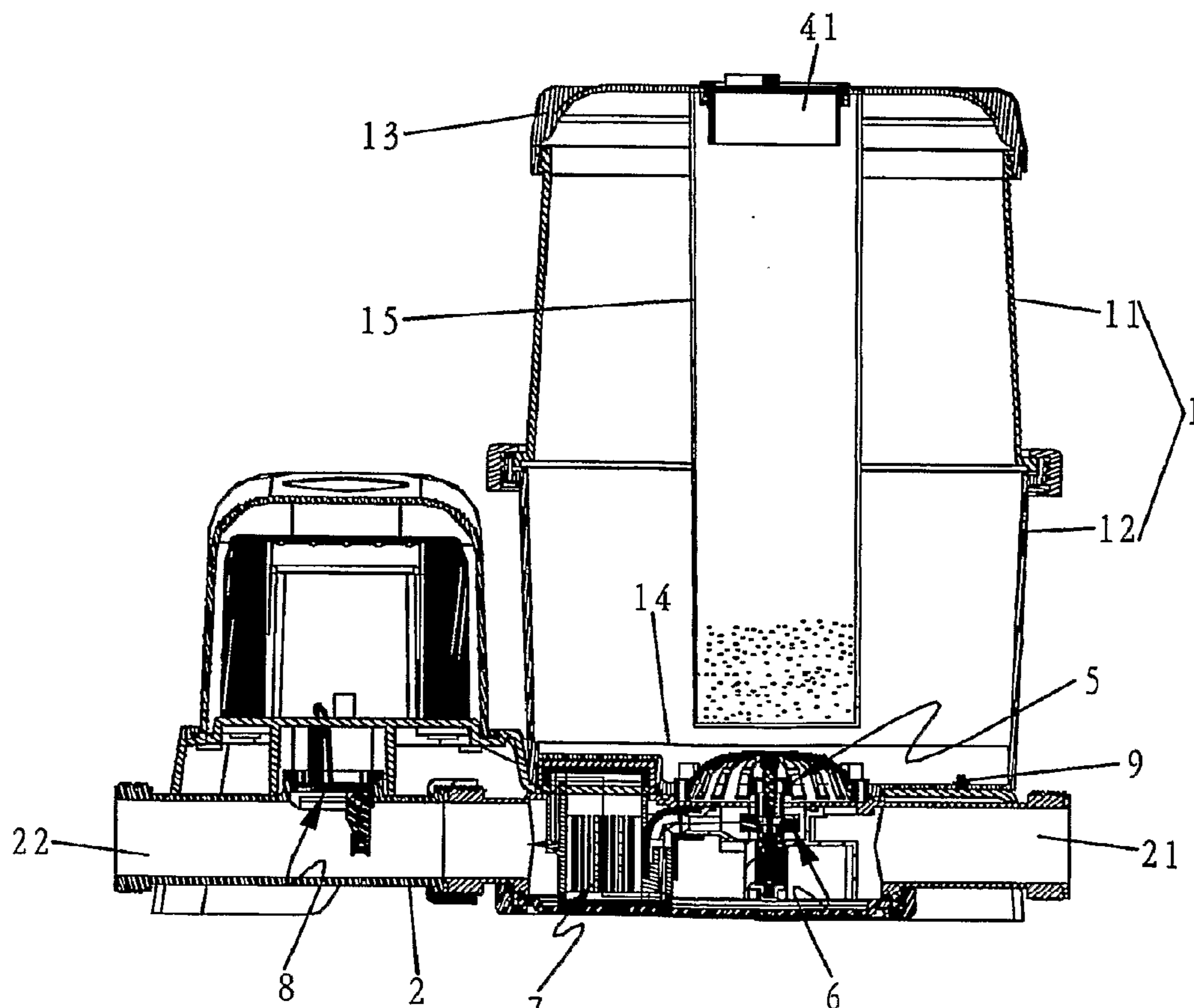

FIG. 3

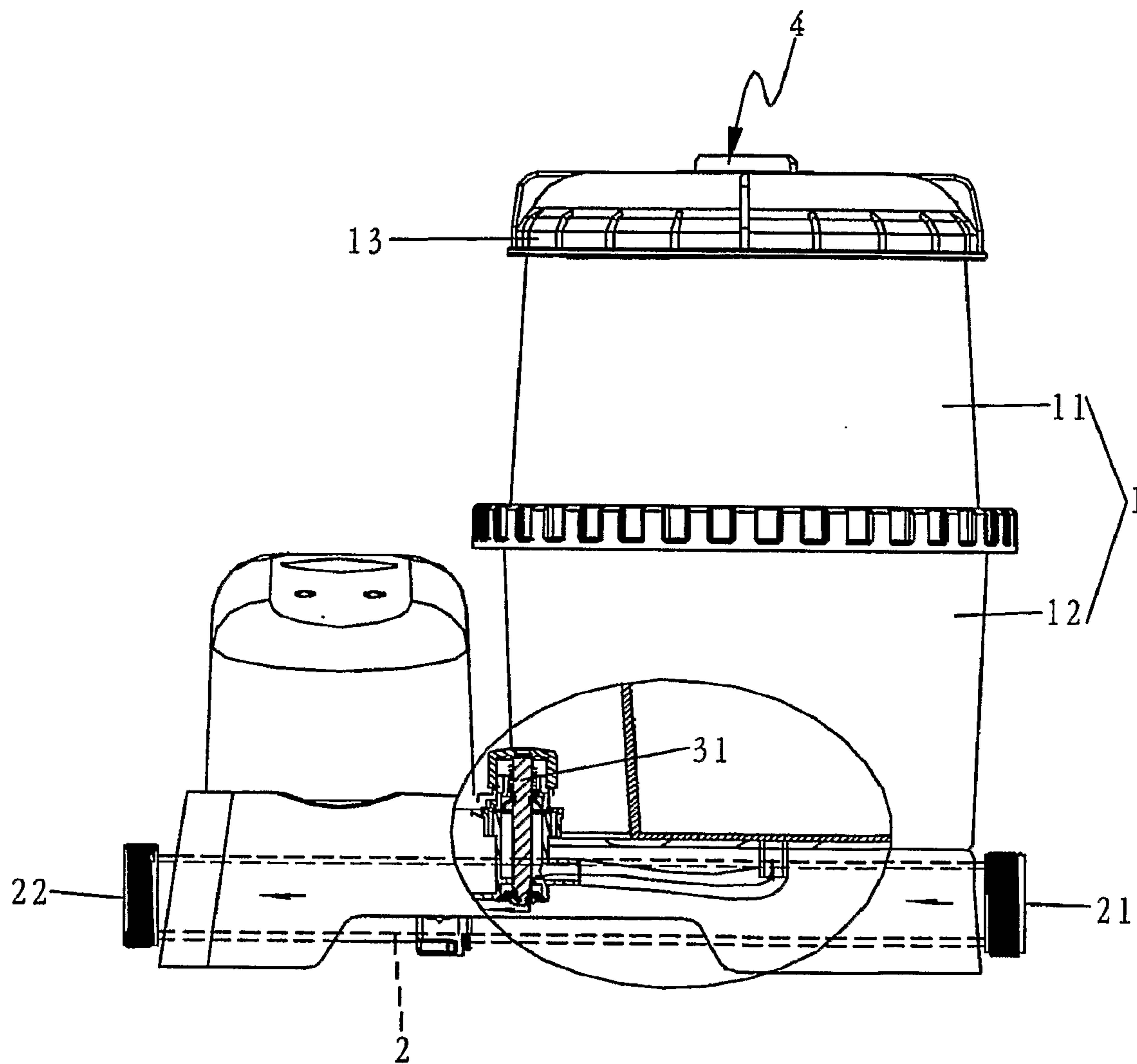

FIG. 4

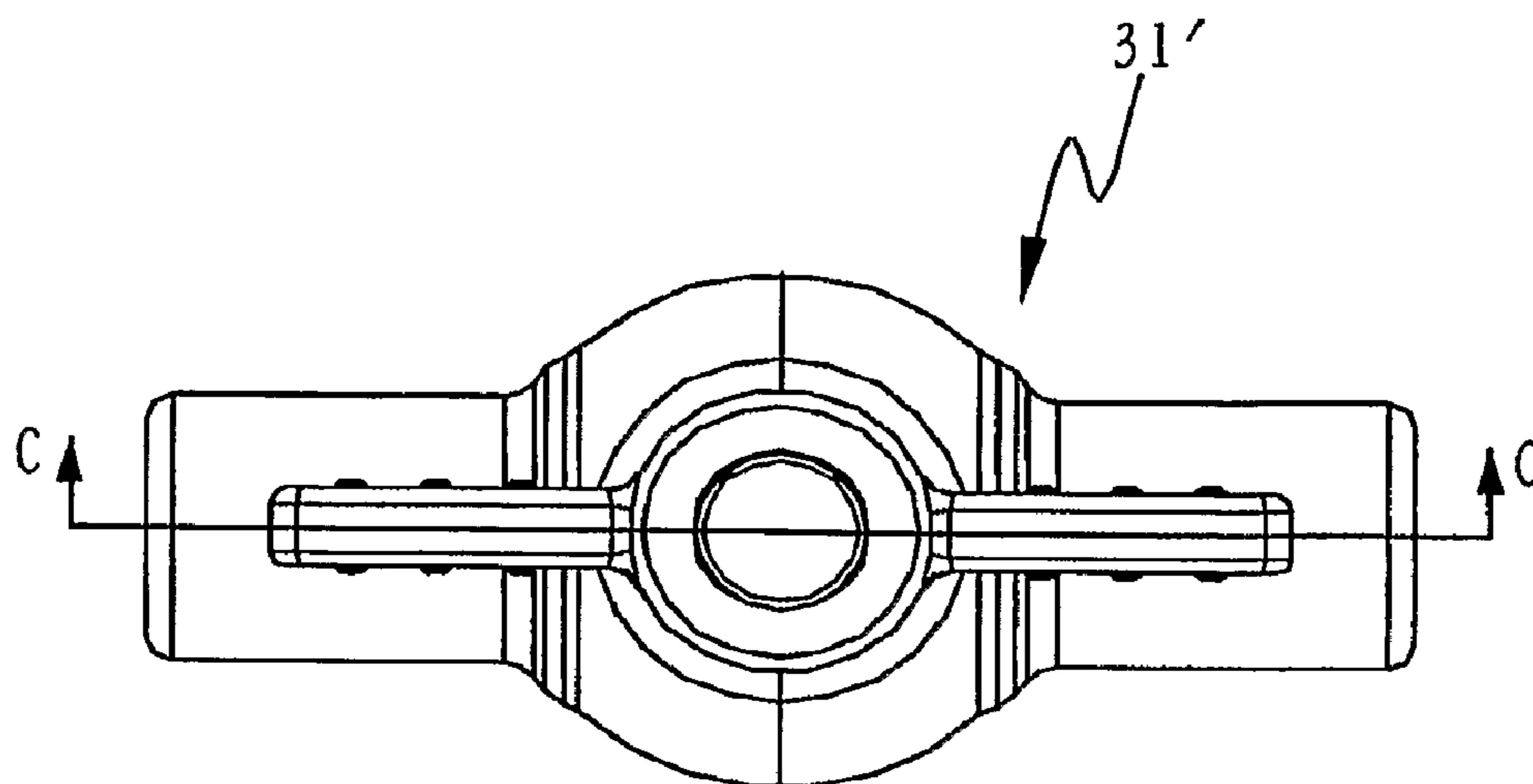

FIG. 5A

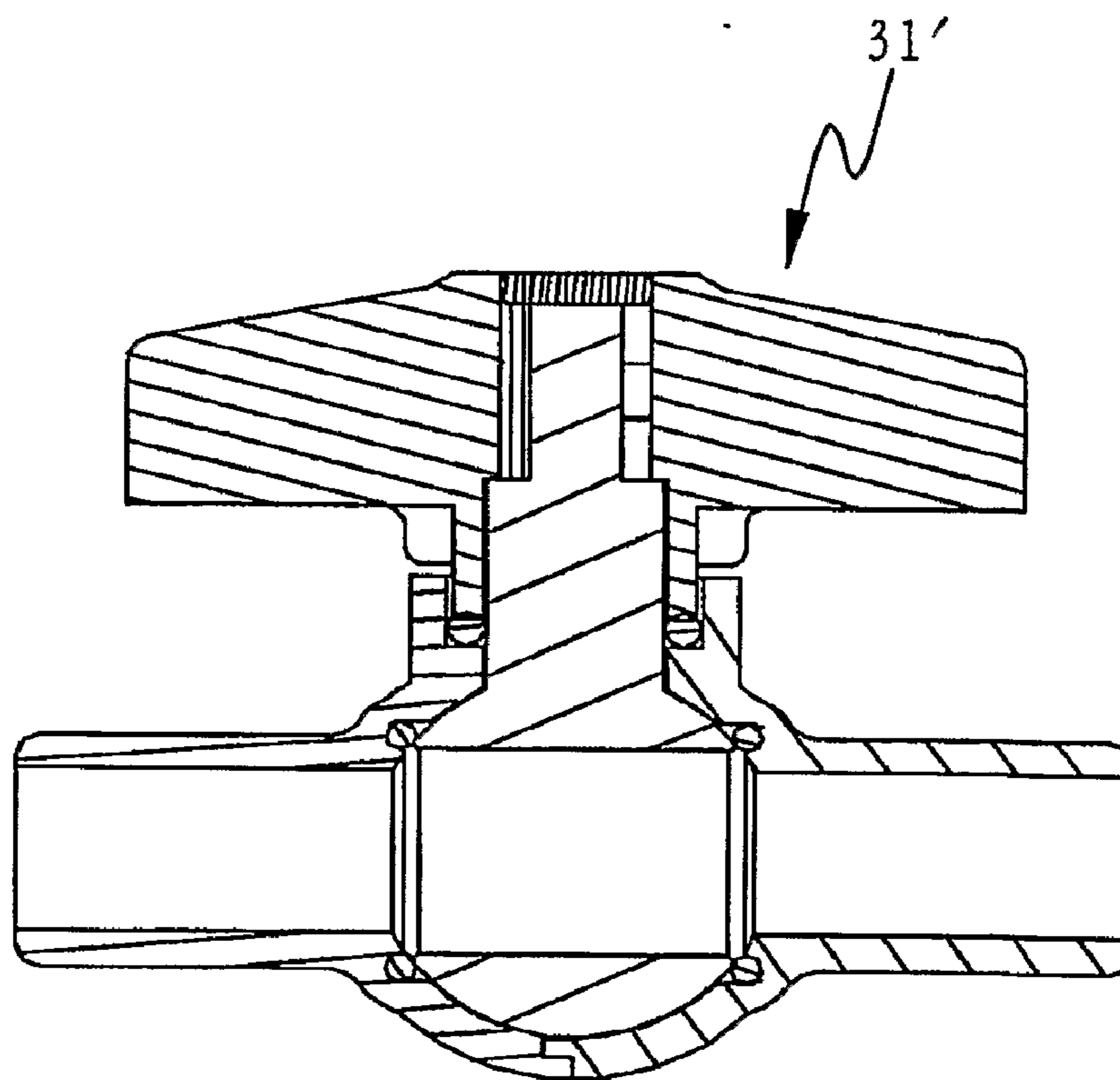

FIG. 5B

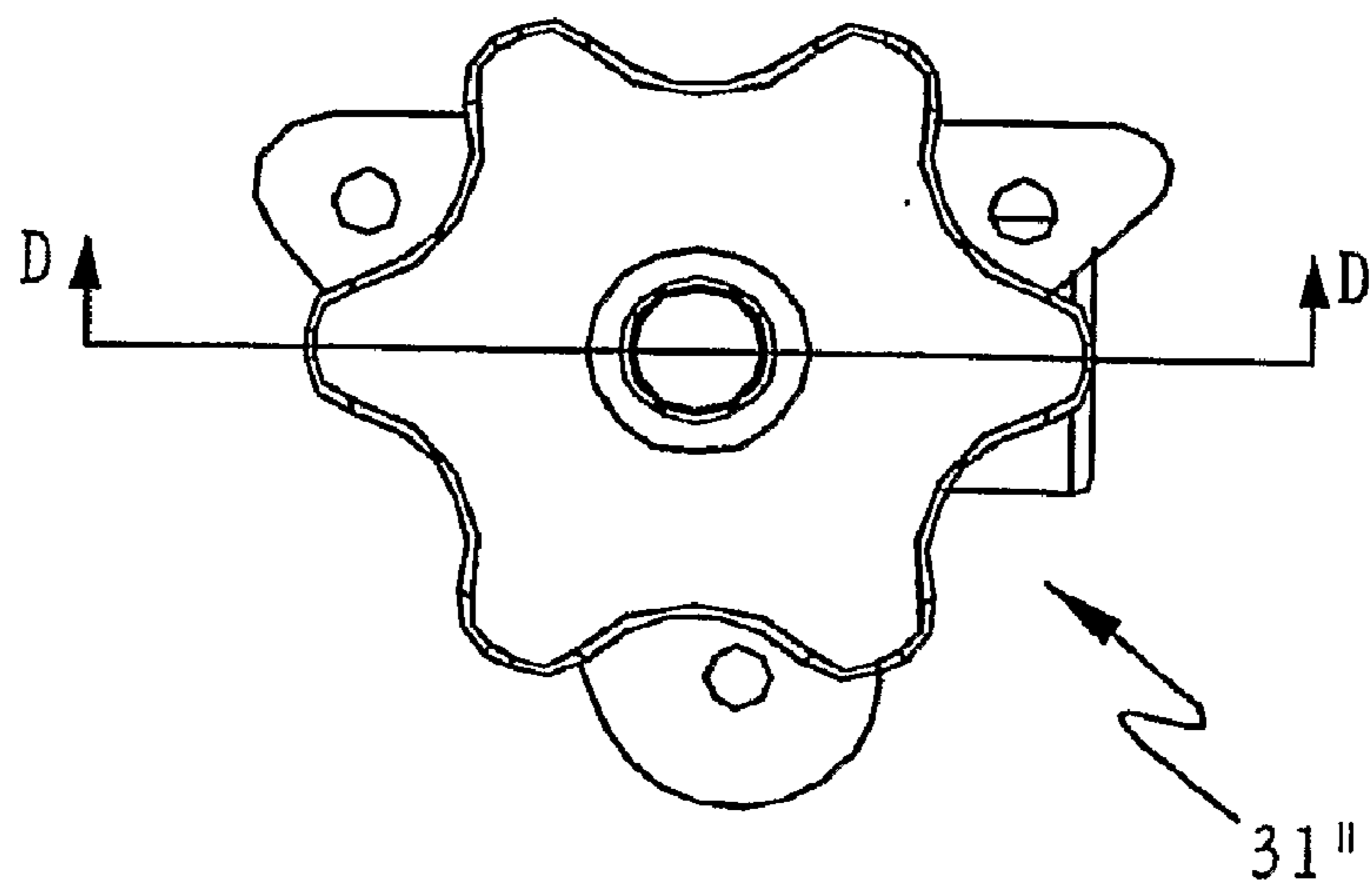

FIG. 6A

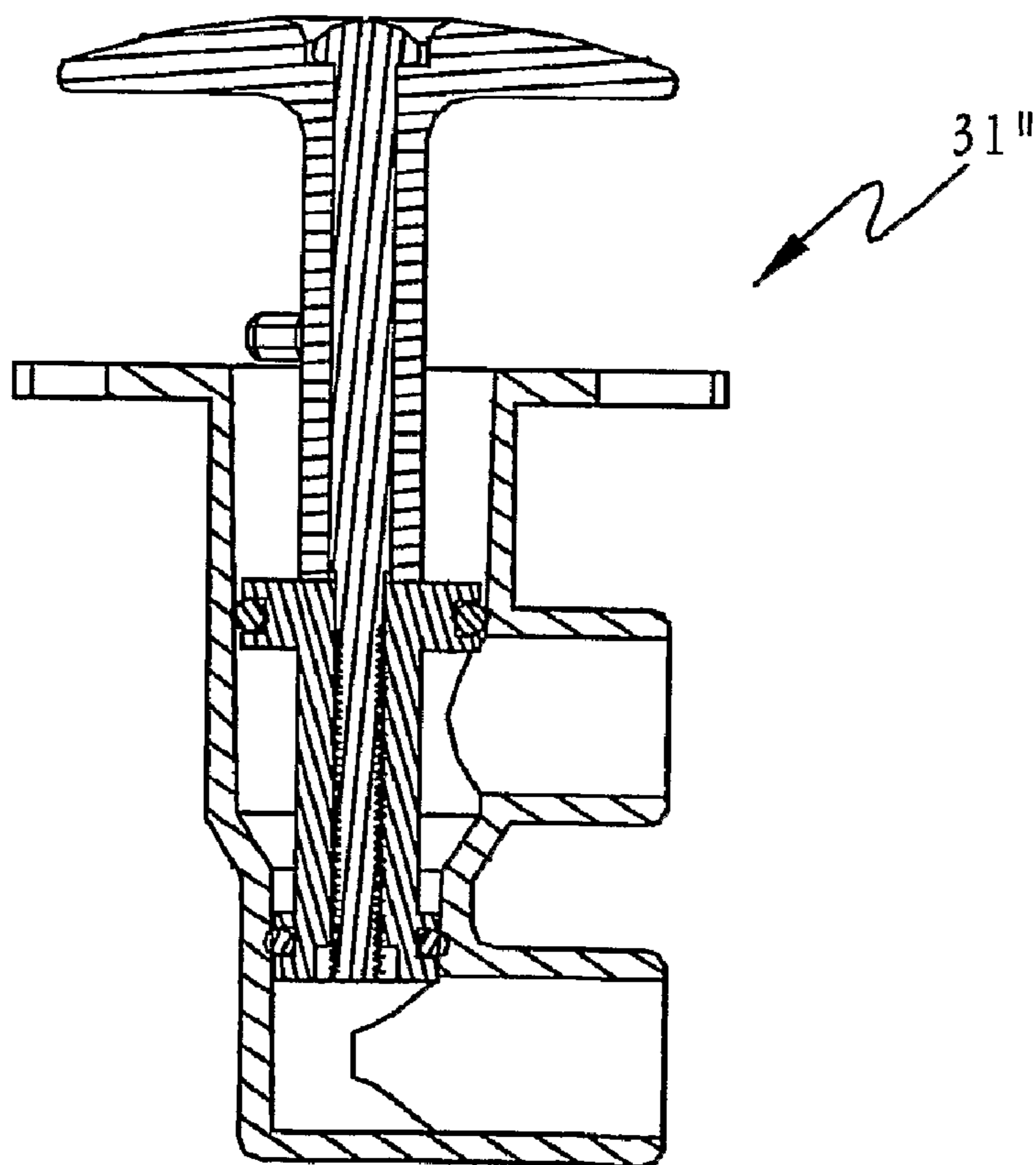

FIG. 6B

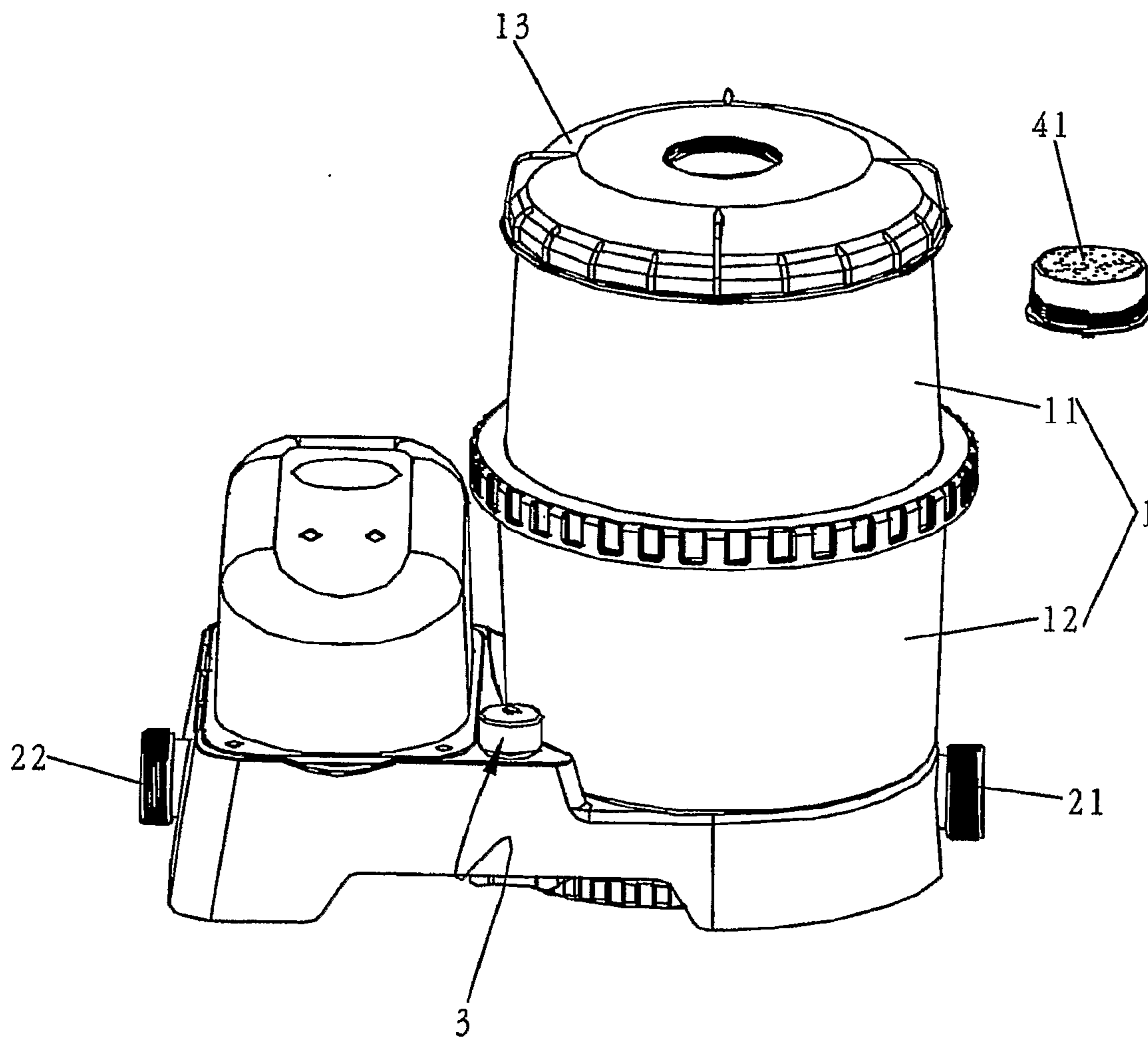

FIG. 7

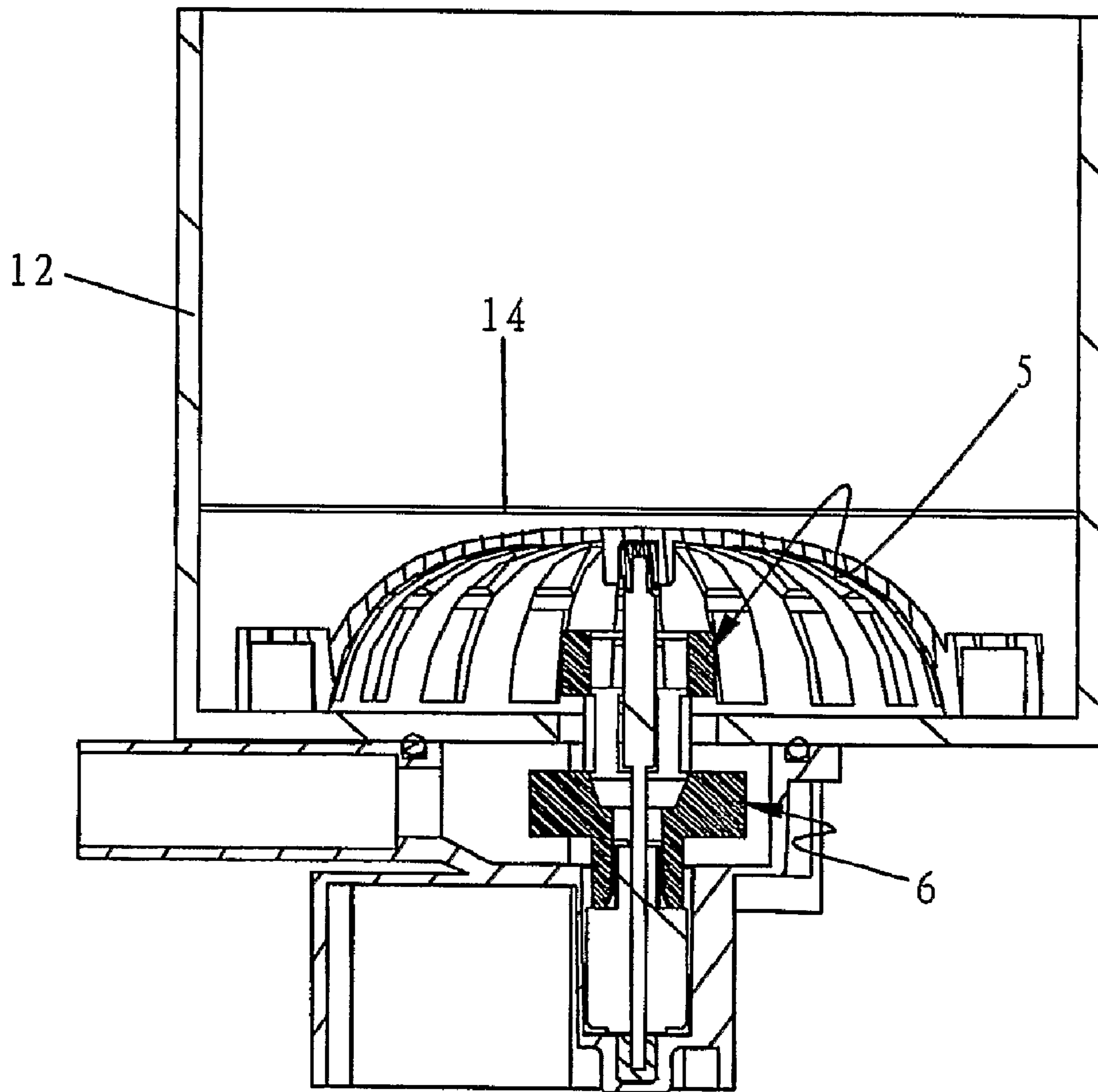

FIG. 8

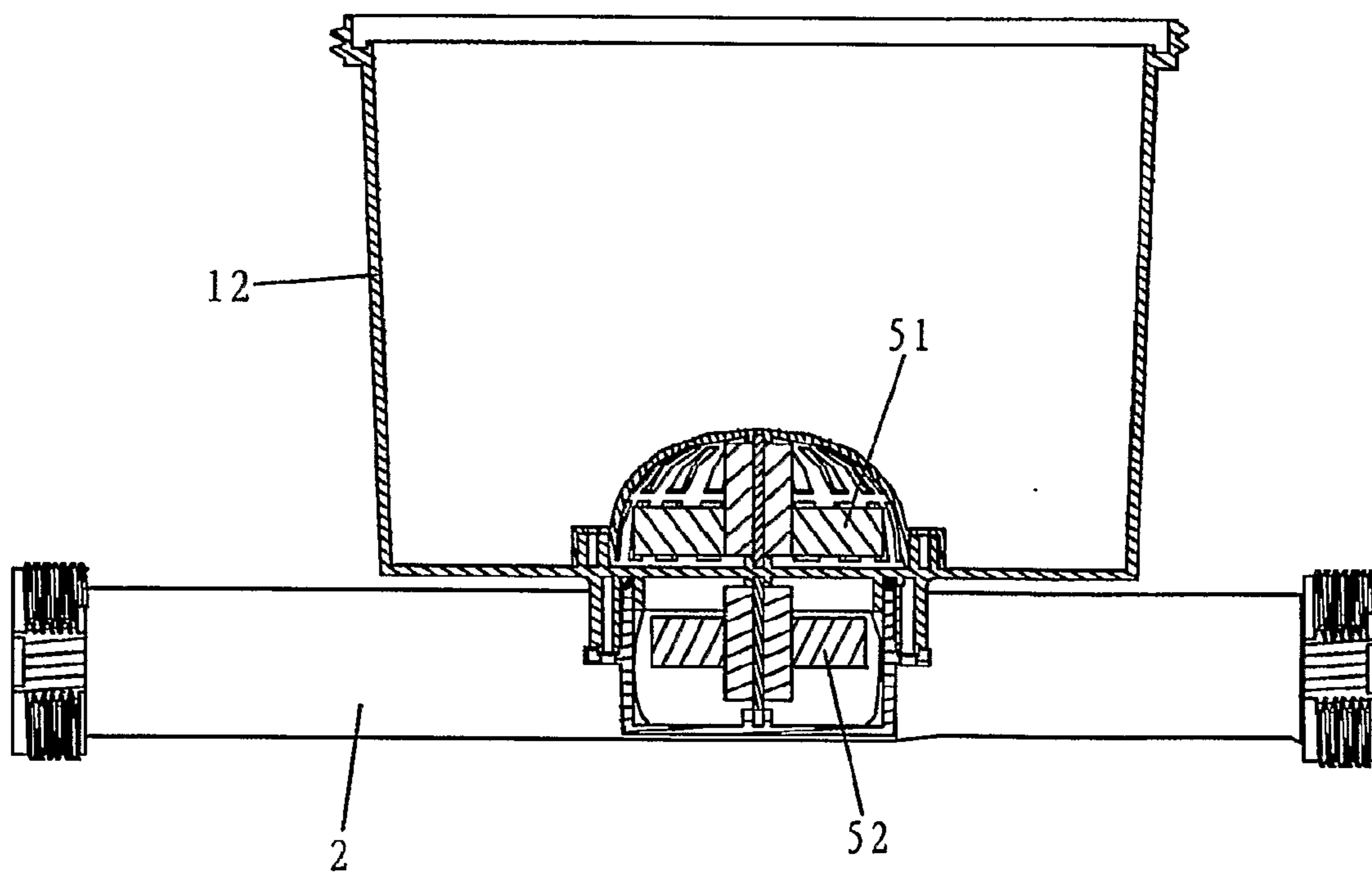

FIG. 9

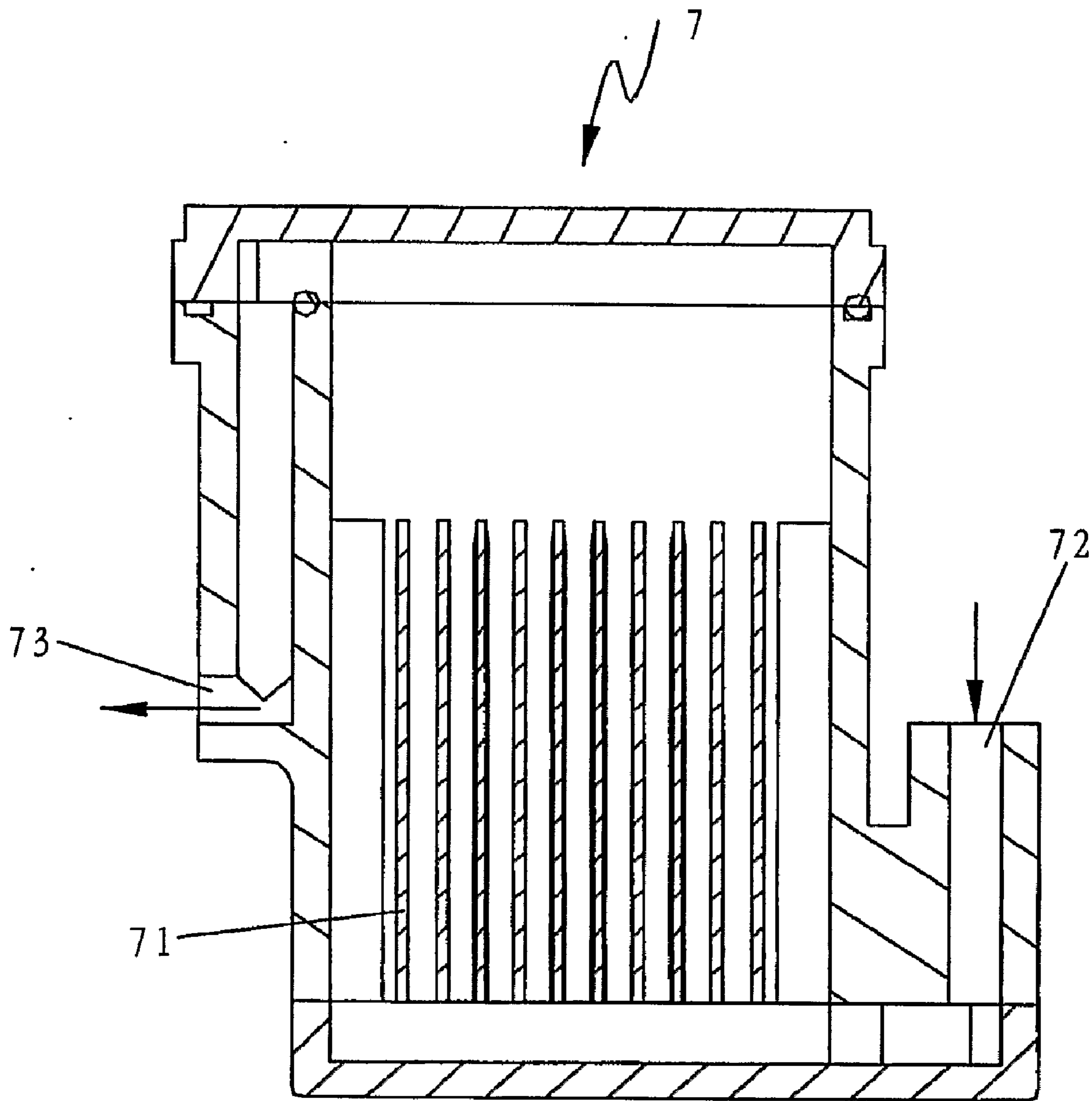

FIG. 10

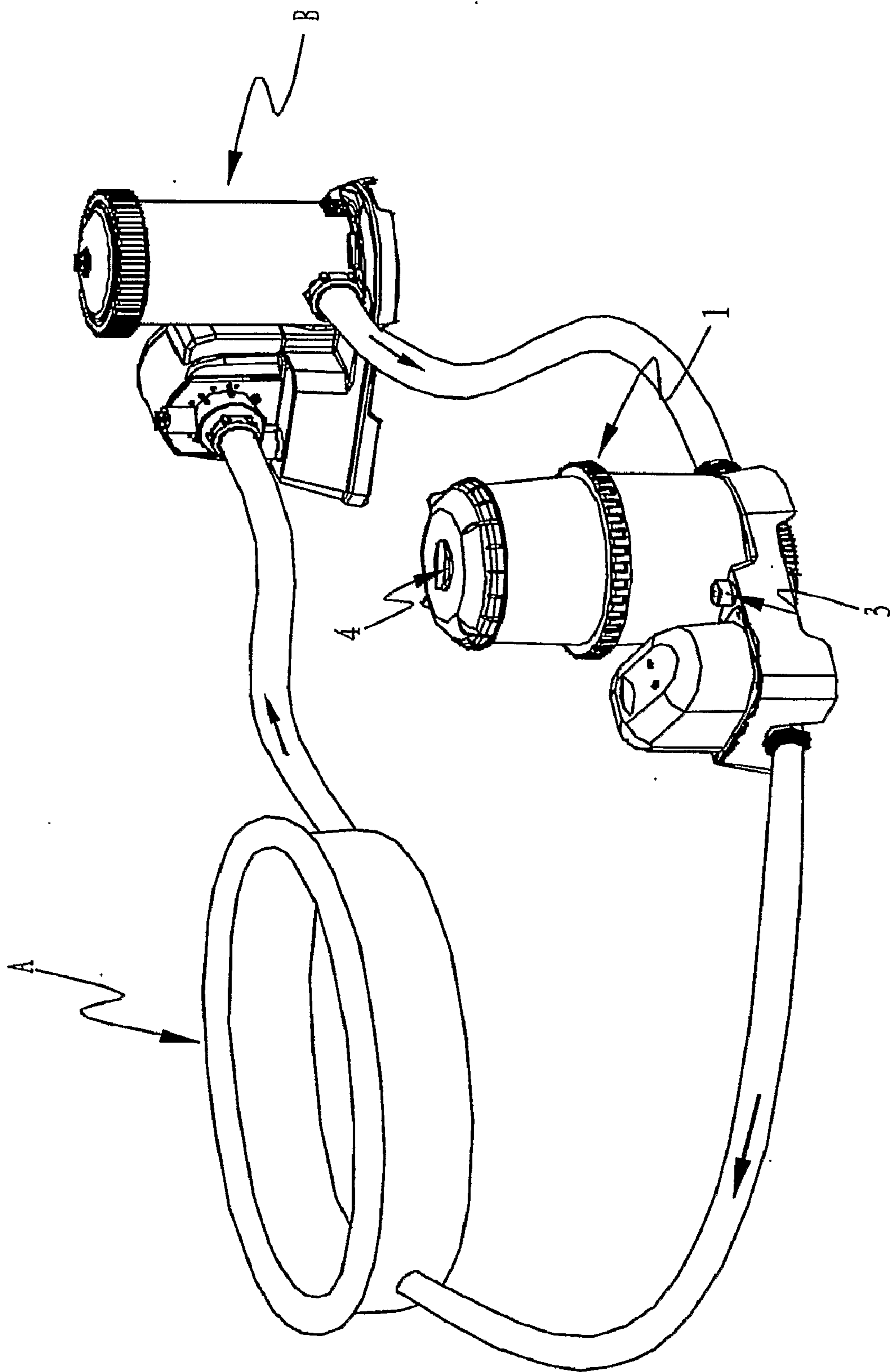

FIG. 11

Fig. 12

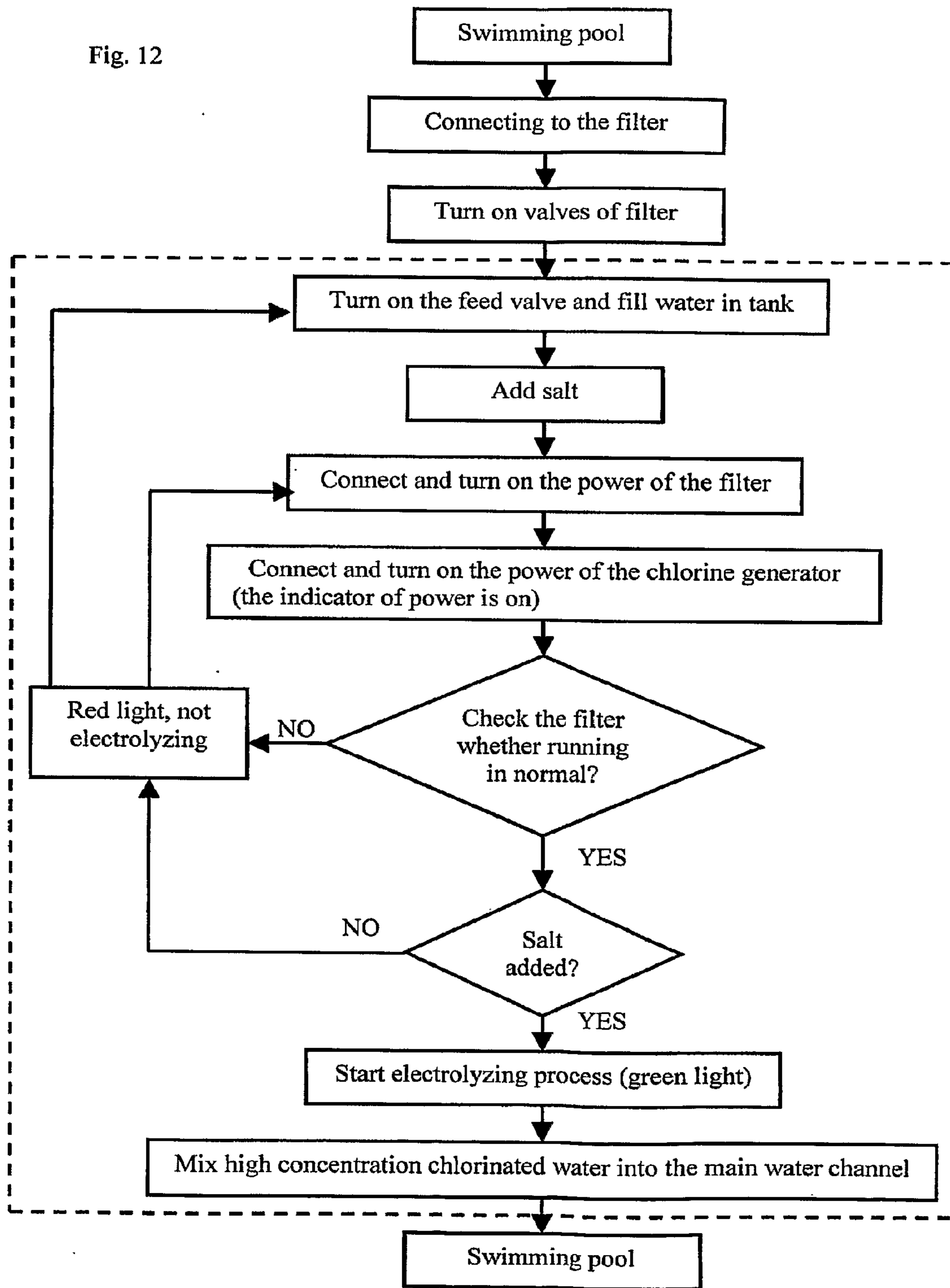

Fig. 13

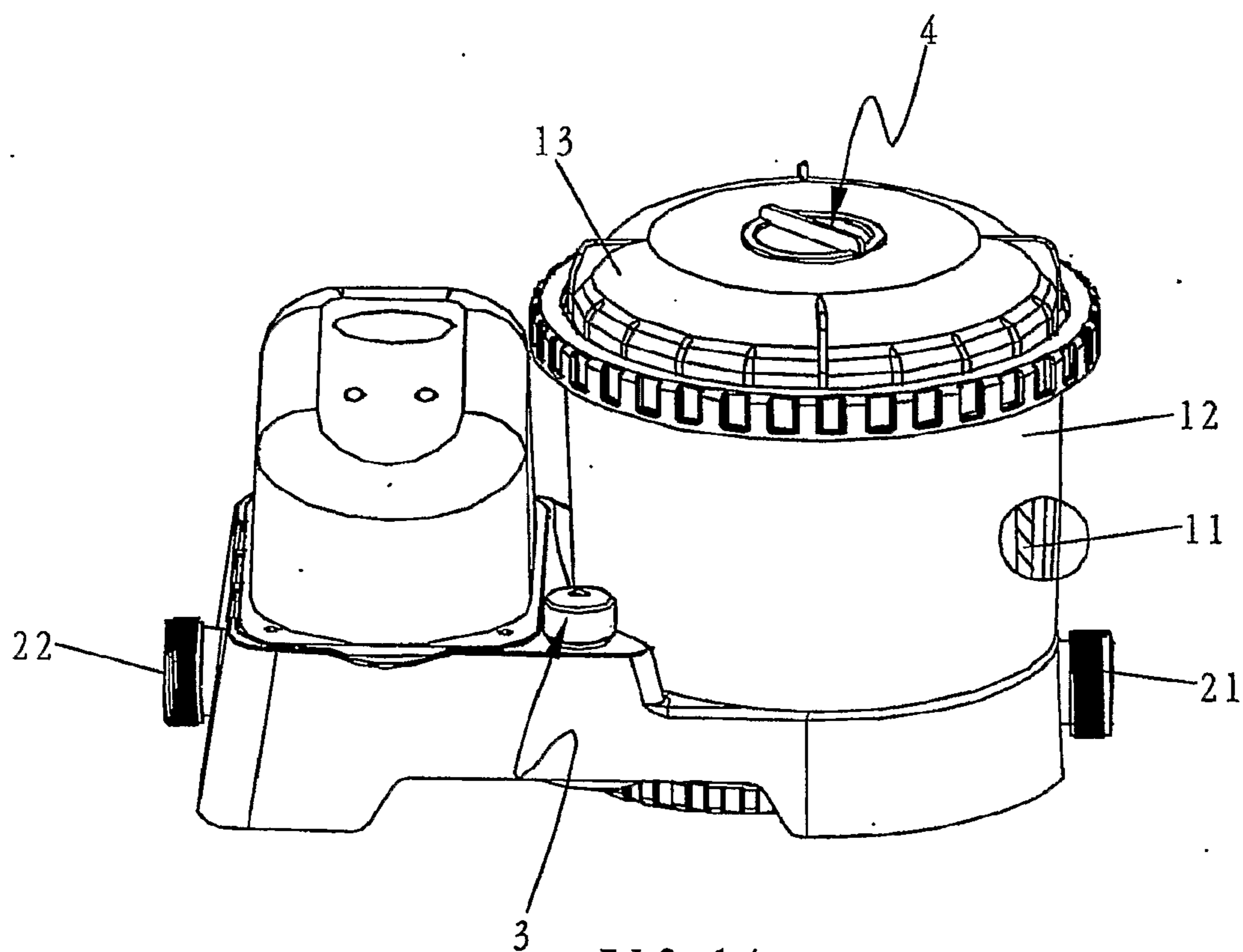
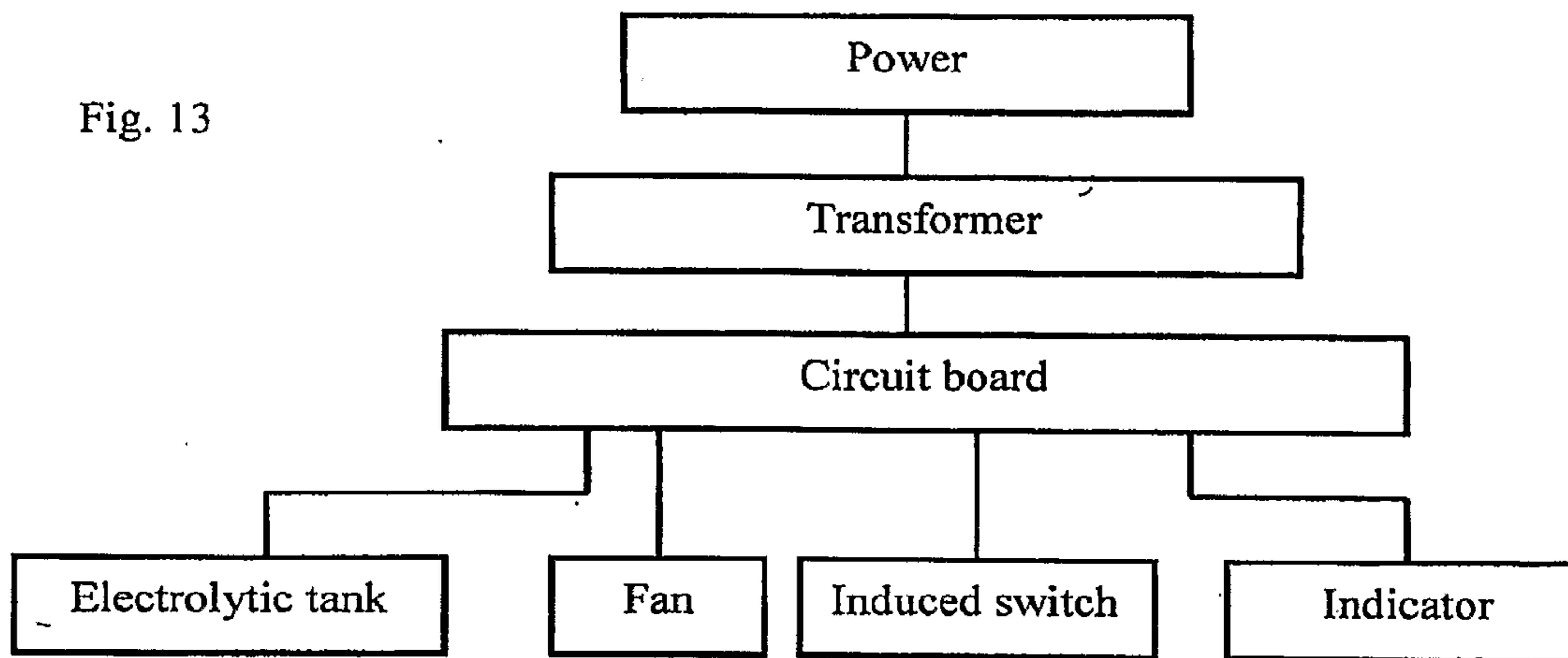

FIG. 14

CHLORINE GENERATOR

BACKGROUND OF THE INVENTION

[0001] 1. Field of the Invention

[0002] The present invention relates to a chlorine generator, and more particularly to a chlorine generator for use with a swimming pool.

[0003] 2. Description of the Related Art

[0004] A small amount of chlorine can function as a disinfectant, and is thus often used in swimming pools by dissolving chlorine in the water of the swimming pool to disinfect the swimming pool. To generate chlorine, a conventional method is to set up a chlorine generator (an electrolytic tank) at the outlet of a circulating filter of the pool. To produce chlorine, a certain amount of salt (NaCl) is dissolved into the swimming pool so as to make the water therein a saline solution of certain salinity. The water is then brought into the circulating filter. After passing through the filter, the water flows through the electrolytic tank, where the water having certain salinity undergoes a chemical reaction (electrolysis) inside the saline electrolytic tank. The chemical reaction produces chlorine and hydrogen at the same time, and the chlorine dissolves into the water which flows back into the swimming pool. In this way, while filtering the water of the swimming pool, the saline solution is treated in electrolysis reaction to produce chlorine. The treatment process is continuous, and the saline solution in the swimming pool is gradually transformed into water containing chlorine to perform the disinfection function.

[0005] This saline electrolysis method has the following shortcomings:

[0006] 1. Because the salt has to be pre-dissolved into the swimming pool, it is often difficult to completely and uniformly dissolve the salt in a large pool of water. This adversely affects the efficiency of the electrolysis.

[0007] 2. Because the salt is directly dissolved into the swimming pool, the salt concentration cannot be too high or it will be harmful to the skin of the swimmers. Electrolyzing the low-concentration saline solution will result in low electrolyzing efficiency.

[0008] 3. Even though the water in the pool is relatively low in salt concentration, due to the volume of the swimming pool, a large amount of salt is needed, which often leads to waste.

[0009] 4. The impurities in the salt directly enter the swimming pool, causing water pollution.

SUMMARY OF THE INVENTION

[0010] Accordingly, the present invention is directed to a chlorine generator that substantially obviates one or more of the problems due to limitations and disadvantages of the related art.

[0011] It is an object of the present invention to provide a chlorine generator that can generate chlorine to disinfect the water of a swimming pool without directly dissolving salt in the swimming pool, so as to improve saline electrolysis efficiency.

[0012] Additional features and advantages of the invention will be set forth in the descriptions that follow and in part will be apparent from the description, or may be learned by practice of the invention. The objectives and other advantages of the invention will be realized and attained by the structure

particularly pointed out in the written description and claims thereof as well as the appended drawings.

[0013] To achieve the above-mentioned object, the present invention provides a chlorine generator, which includes a brine tank, a main water channel, a subsidiary water channel connected between an upstream point and a downstream point on the main water channel, a stirring device located at the bottom side of the brine tank, and an electrolytic tank for generating chlorine from a saline solution by an electrolysis reaction, wherein the brine tank, the stirring device and the electrolytic tank are located on the subsidiary water channel, whereby chlorinated water from the electrolytic tank enters the main water channel.

[0014] It is to be understood that both the foregoing general description and the following detailed description are exemplary and explanatory and are intended to provide further explanation of the invention as claimed.

BRIEF DESCRIPTION OF THE DRAWINGS

[0015] FIG. 1 is a perspective view of a chlorine generator according to an embodiment of the present invention.

[0016] FIG. 2 is a top plan view of the chlorine generator of FIG. 1.

[0017] FIG. 3 is a sectional view showing the A-A section of FIG. 2.

[0018] FIG. 4 is a partial sectional view showing the B-B section (showing the feed valve) of FIG. 2.

[0019] FIG. 5A is a top plan view showing an alternative feed valve in a chlorine generator according to an embodiment of the present invention.

[0020] FIG. 5B is a sectional view showing the C-C section of FIG. 5A.

[0021] FIG. 6A is a top plan view showing another alternative feed valve according to an embodiment of the present invention.

[0022] FIG. 6B is a sectional view showing the D-D section of FIG. 6A.

[0023] FIG. 7 illustrates a step of adding salt into the chlorine generator of FIG. 1.

[0024] FIG. 8 is a sectional view of the stirring device of the chlorine generator of FIG. 1.

[0025] FIG. 9 is a sectional view of an alternative stirring device according to an embodiment of the present invention.

[0026] FIG. 10 is a sectional view showing the electrolytic tank of the chlorine generator of FIG. 1.

[0027] FIG. 11 shows a chlorine generator according to embodiments of the present invention connected with a pool.

[0028] FIG. 12 is a flow diagram illustrating the operation of a chlorine generator according to embodiments of the present invention.

[0029] FIG. 13 is a block diagram showing various components of a chlorine generator according to embodiments of the present invention.

[0030] FIG. 14 is a perspective view showing a chlorine generator in a packaged state.

DETAILED DESCRIPTION OF THE PREFERRED EMBODIMENTS

[0031] Referring to FIG. 1 to FIG. 3, a chlorine generator according to embodiments of the present invention includes a brine tank 1, a main water channel 2, a feed valve 3, a salt port cover 4, a stirring device 5, a pump 6, and an electrolytic tank 7. The feed valve 3, the brine tank 1, and the electrolytic tank

7 are located on a subsidiary water channel in that order. Water enters the subsidiary channel from a first point on the main water channel and returns to a second point on the main water channel which is downstream from the first point. The pump 6 is located in the subsidiary water channel, preferably between the brine tank 1 and the electrolytic tank 7, to facilitate the saline flow into the electrolytic tank. The stirring device 5 in the brine tank 1 is also located in the subsidiary water channel, upstream from the pump 6. The brine tank 1 includes a dismountable upper drum 11 and a lower drum 12, a cap 13 covering the top side of the upper drum 1, and a filter screen 14 inside the brine tank 1. The main water channel 2 is located at the bottom or a side of the brine tank 1. Its inlet 21 is connected to the filter of the swimming pool and its outlet 22 is connected to the swimming pool.

[0032] The feed valve 3 (shown in FIG. 4) is a valve switch 31 located on the subsidiary water channel between the main water channel 2 and the brine tank 1 for controlling the flow of water from the main water channel 2 to the brine tank 1. The valve switch 31 may be a press-down valve, as showing in FIG. 4, which can be turned on or off by pressing down or pulling up the handle of the valve. Alternatively, the valve switch 31 may be a rotary valve, as shown in FIG. 5A and FIG. 5B, which can be turned on or off by turning the ball valve 31'. As another alternative, FIG. 6A and FIG. 6B show the valve switch 31 as a push-pull valve which is turned off or on by pushing or pulling the push-pull valve 31".

[0033] The salt port cover 4 may be an inverted measuring cup 41 covering a port in the cap 13 of the brine tank 1 (shown in FIG. 7). When adding salt, the measuring cup 41 may be taken off and conveniently used to measure an appropriate amount of salt, and returned to cover the cap 13.

[0034] The stirring device 5 is located on the bottom of the brine tank 1 and is used for stirring the salt and water inside the tank after water is introduced into the tank in order to completely dissolve the salt to form a high concentration saline. The pump 6 is located downstream from the stirring device 5 for pumping the saline from the brine tank 1 into the electrolytic tank 7. The stirring device 5 and the pump 6 can be mounted on a common shaft driven by a motor to carry out stirring and pumping at the same time, as shown in FIG. 8. Of course, the stirring device 5 and the pump 6 can also be driven by separate motors. The stirring device 5 can also be driven by water power, as shown in FIG. 9, where stirring blades 51 of the stirring device 5 are mounted on the top end of a shaft and disposed inside the brine tank 1, and driving blades 52 are mounted at the lower end of the shaft and disposed inside the main water channel 2 for driving the stirring blades 51 by water power.

[0035] The electrolytic tank 7 (shown in FIG. 10) is located downstream from the pump 6, and has several titanium plates 71 inside for generating chlorine from saline solution in an electrolysis process. The inlet 72 of the electrolytic tank 7 is connected to the pump 6, and the outlet 73 is connected to the main water channel 2. The water flows upwards inside the electrolytic tank 7.

[0036] The operation and working principle of the device according to embodiments of the present invention, as shown in FIG. 11 to FIG. 13, are as follows. The chlorine generator is connected between the swimming pool A and the filter B and downstream from the filter. To start, turn on all valves in the loop, then turn on the inlet valve for the brine tank 1 (i.e. the feed valve 3 in this embodiment) to fill the brine tank with an appropriate amount of water. Next, add an appropriate

amount of salt into the brine tank 1, and turn on the filter and the power of the chlorine generator. The water drawn up from the swimming pool A passes through the filter B for filtering treatment, then enters the main water channel 2 of the chlorine generator. At this time, because the feed valve 3 is open, an amount of water enters the brine tank 1 via the subsidiary water channel, where the water is stirred with salt by the stirring device 5 to fully dissolve the salt and form a high salt concentration solution. Meanwhile, the filter screen 14 can filter the impurities and the particulate in the salt to prevent them from entering the stirring device 5 and the electrolytic tank 7. The filter screen 14 also filters the water from the pool. Then, the high concentration saline is pumped into the inside of the electrolytic tank 7 by the pump 6 for electrolytic treatment. Due to the high concentration of the saline, much more chlorine can be produced (as compared to the conventional method of dissolving salt in the pool). The chlorine dissolves into the water to form high concentration chlorinated water. The high concentration chlorinated water flows into the main water channel 2 via the outlet 73 of the electrolytic tank 7 to mix with the water therein, where the chlorine is diluted to form a lower concentration chlorinated water with disinfection effect without harming the skin of swimmers. The diluted chlorinated water flows back to the swimming pool A, completing the cycle.

[0037] Referring to FIG. 10, the electrolytic tank 7 is shown, where the water flow is from the bottom of the tank 7 to the top passing by the surfaces of the vertical titanium plates 71. The saline can be electrolyzed fully in this process, and the chlorine and hydrogen bubbles generated by the process rise up vertically without being obstructed. The hydrogen bubbles will exit the surface of the water in the electrolytic tank 7, and the chlorine bubbles will dissolve into the water in the electrolytic tank 7 to form chlorinated water, which subsequently enters the main water channel 2. If the water entering the electrolytic tank 7 comes from the top of the tank, the hydrogen bubbles will be generated and accumulate near the bottom portion of the titanium plates 71, causing a portion of the titanium plates 71 to be ineffective, increasing electrical resistance and reducing chlorine output.

[0038] Further, the multi-segmented brine tank 1 that includes a dismountable upper drum 11 and a lower drum 12, as shown in FIG. 14, makes packaging easier. The upper drum can be turned over and stored inside the lower drum to facilitate packaging and to save space as well as packing and transportation cost.

[0039] Additionally, referring again to FIG. 3, to detect the rate of flow in the main water channel 2, a flow valve 8 may be provided inside the main water channel 2. When the rate of flow is insufficient (i.e. below a predetermined value), the flow valve 8 will turn off the electrolytic circuit to stop electrolysis in tank 7, thereby preventing the highly chlorinated solution from flowing directly into the swimming pool and preventing harmful effect to the skin of the swimmers. In addition, a water level detector 9 may be provided inside the brine tank 1, so that the electrolytic circuit can be turned off to stop electrolysis in the tank 7 if the water level in the brine tank 1 is insufficient (i.e. below a predetermined value). This prevents the motor from running without load in the brine tank 1 and prevents the electrolytic tank 7 from carrying out electrolysis with an insufficient amount of saline.

[0040] Referring to FIG. 3 again, the filter screen 14 can be replaced by a water permeable sack 15. When salt is added to the sack 15, the salt in the sack is dissolved and enters the tank

1, and the saline is pumped into the electrolytic tank **7** by the pump **6**. The impurities and particulate remain in the sack bag **15**, preventing them from falling into the stirring device **5** and the electrolytic tank **7**. After use, the sack **15** can be taken out to be cleaned or replaced. Of course, the filter screen **14** and the water permeable sack **15** can be used simultaneously.

[0041] Using the chlorine generator according to embodiments of the present invention, salt can be added into the brine tank and fully dissolved in the water therein for the electrolysis reaction. This eliminates the need to dissolve salt into the swimming pool directly. The saline in the brine tank can have a high salt concentration, and the salt quantity in the brine tank can be controlled without wasting salt. In addition, by employing a constant current control for the electrolytic tank, there is no need to measure the salt concentration in the brine tank.

[0042] Other advantages of the chlorine generator include:

[0043] 1. By using the stirring device, salt can be stirred and dissolved fully in the brine tank, then introduced into the electrolytic tank for the electrolysis reaction. This increases the efficiency and completeness of the electrolysis.

[0044] 2. Because water flows from the bottom to the top in the electrolytic tank, the hydrogen bubbles generated in the electrolysis process will float upward through the water between the titanium plates. This prevents hydrogen from blocking the effective area of the titanium plates which could cause increased resistance and reduced chlorine production efficiency.

[0045] 3. By using a flow valve in the main water channel, the rate of flow in the main water channel can be detected, so that the electrolytic tank can be turned off when the flow in the main water channel is insufficient. This prevents high concentration chlorinated water from entering the pool.

[0046] 4. By using a multi-segmented brine tank that includes upper and low drums, the upper drum can be stored inside the low drum when not in use, which facilitates packaging and saves space as well as packing and transportation cost.

[0047] It will be apparent to those skilled in the art that various modification and variations can be made in the chlorine generator of the present invention without departing from the spirit or scope of the invention. Thus, it is intended that the present invention cover modifications and variations that come within the scope of the appended claims and their equivalents.

What is claimed is:

1. A chlorine generator, comprising:

a brine tank;

a main water channel;

a subsidiary water channel connected between an upstream point and a downstream point on the main water channel;

a stirring device located at the bottom side of the brine tank; and

an electrolytic tank for generating chlorine from a saline solution by an electrolysis reaction,

wherein the brine tank, the stirring device and the electrolytic tank are located on the subsidiary water channel, whereby chlorinated water from the electrolytic tank enters the main water channel.

2. The chlorine generator as claimed in claim **1**, further comprising a feed valve located between the main water channel and the brine tank on the subsidiary water channel for controlling water flow from the main water channel to the brine tank.

3. The chlorine generator as claimed in claim **2**, wherein the feed valve is a press-down valve, a rotary valve or a push-pull valve.

4. The chlorine generator as claimed in claim **1**, wherein the stirring device includes stirring blades driven by a motor or by water power.

5. The chlorine generator as claimed in claim **1**, further comprising a pump located on the subsidiary water channel between the stirring device and the electrolytic tank for pumping saline from the brine tank into the electrolytic tank, wherein the stirring device and the pump are either mounted on a common shaft driven by a motor or are driven by separate motors.

6. The chlorine generator as claimed in claim **1**, wherein the electrolytic tank includes a plurality of vertical titanium plates for carrying out the electrolysis reaction, and wherein water flows upward inside the electrolytic tank.

7. The chlorine generator as claimed in claim **1**, further including a flow valve in the main water channel for turning off the electrolytic tank when the water flow in the main water channel is below a predetermined value.

8. The chlorine generator as claimed in claim **1**, wherein the brine tank includes a dismountable upper drum and a lower drum, where the upper drum is capable of fitting in the inside of the lower drum when turned over for packaging.

9. The chlorine generator as claimed in claim **1**, further comprising a filter screen or a water permeable sack inside the brine tank.

10. The chlorine generator as claimed in claim **1**, further comprising a salt port cover for covering a salt port of the brine tank, the salt port cover capable of functioning as a measuring cup.

11. The chlorine generator as claimed in claim **1**, further comprising a water level detector inside the brine tank for turning off the electrolytic tank when the water level inside the brine tank is below a predetermined value.

* * * * *