



(19) **United States**

(12) **Patent Application Publication**  
**Ho et al.**

(10) **Pub. No.: US 2008/0296569 A1**

(43) **Pub. Date: Dec. 4, 2008**

(54) **COMPOUND SEMICONDUCTOR MATERIAL AND METHOD FOR FORMING AN ACTIVE LAYER OF A THIN FILM TRANSISTOR DEVICE**

(75) Inventors: **Jia-Chong Ho**, Taipei Hsien (TW);  
**Jen-Hao Lee**, Taichung (TW);  
**Cheng-Chung Lee**, Taitung (TW);  
**Yu-Wu Wang**, Chu Pei City (TW);  
**Chun-Tao Lee**, Hsinchu (TW);  
**Pang Lin**, Hsinchu (TW)

Correspondence Address:  
**BACON & THOMAS, PLLC**  
**625 SLATERS LANE, FOURTH FLOOR**  
**ALEXANDRIA, VA 22314-1176 (US)**

(73) Assignee: **Industrial Technology Research Institute**, Hsinchu (TW)

(21) Appl. No.: **12/149,113**

(22) Filed: **Apr. 28, 2008**

**Related U.S. Application Data**

(62) Division of application No. 11/489,469, filed on Jul. 20, 2006, which is a division of application No. 10/730,073, filed on Dec. 9, 2003, now abandoned.

(30) **Foreign Application Priority Data**

Sep. 18, 2003 (TW) ..... 092125815

**Publication Classification**

(51) **Int. Cl.**  
**H01L 29/786** (2006.01)

(52) **U.S. Cl.** ..... **257/43; 257/E29.296**

(57) **ABSTRACT**

A compound semiconductor material for forming an active layer of a thin film transistor device is disclosed, which has a group II-VI compound doped with a dopant ranging from 0.1 to 30 mol %, wherein the dopant is selected from a group consisting of alkaline-earth metals, group IIIA elements, group IVA elements, group VA elements, group VIA elements, and transitional metals. The method for forming an active layer of a thin film transistor device by using the compound semiconductor material of the present invention is disclosed therewith.

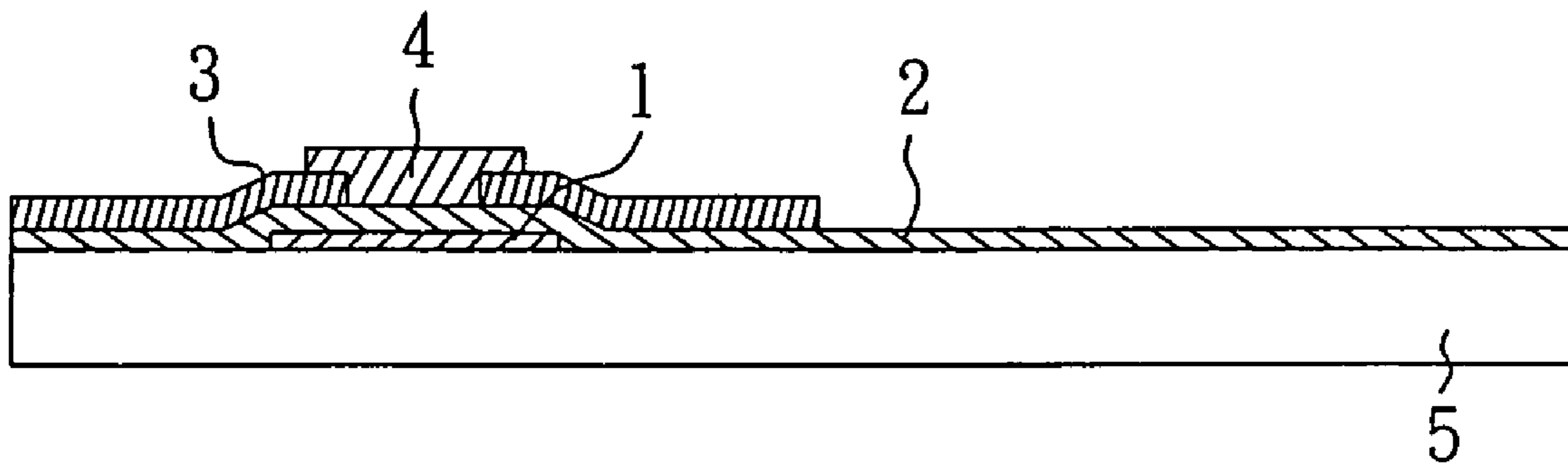

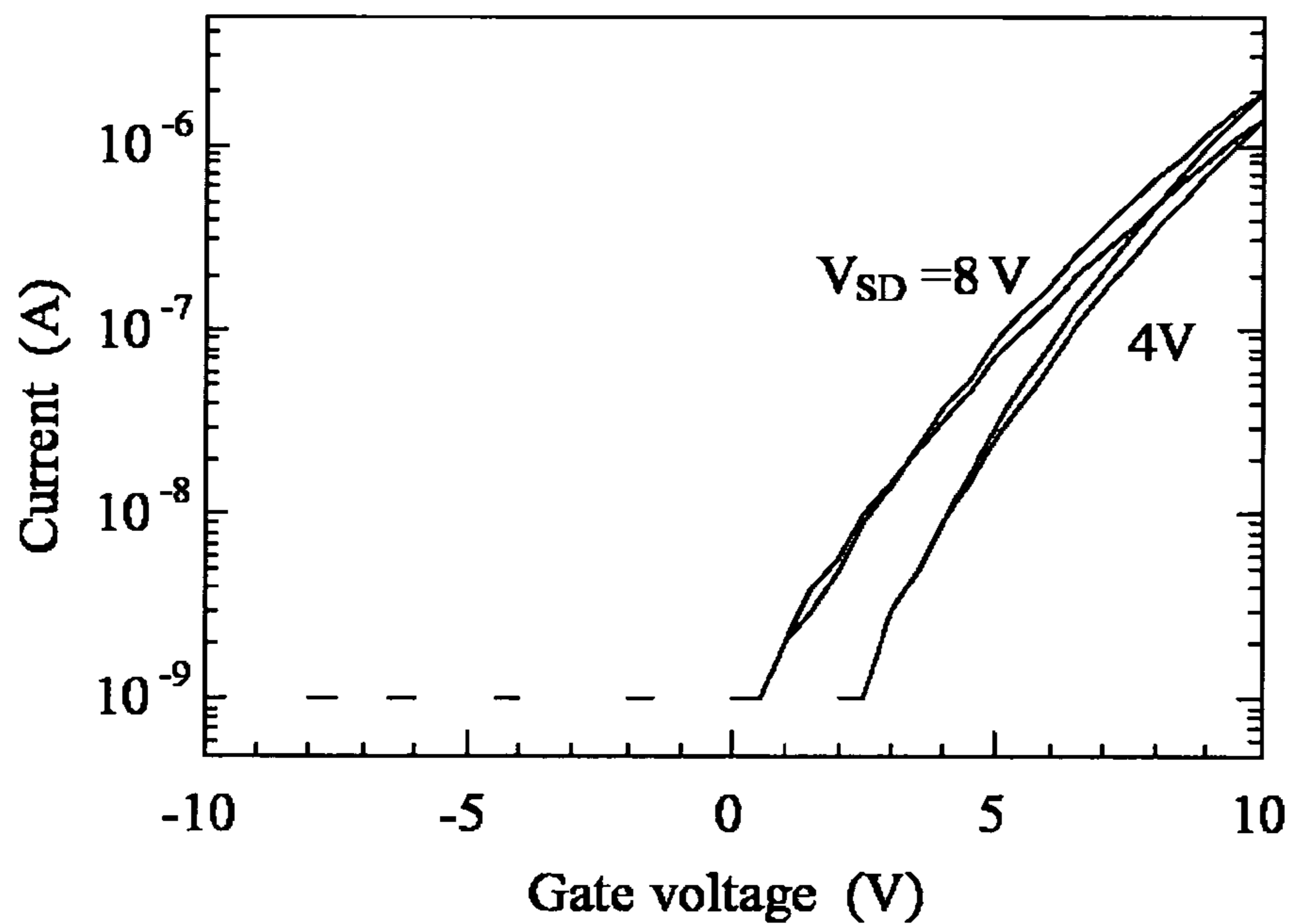

FIG. 1

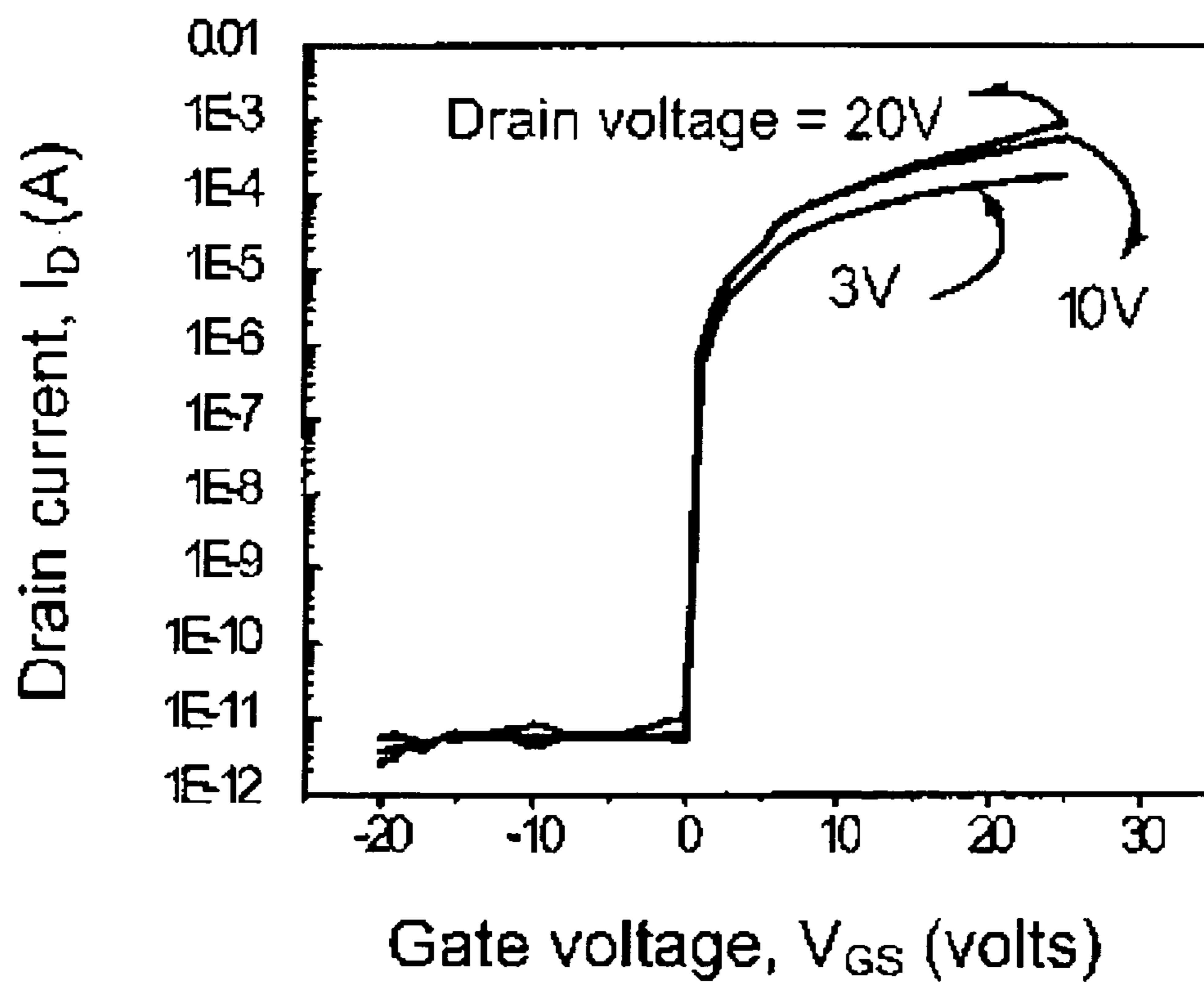

FIG. 2

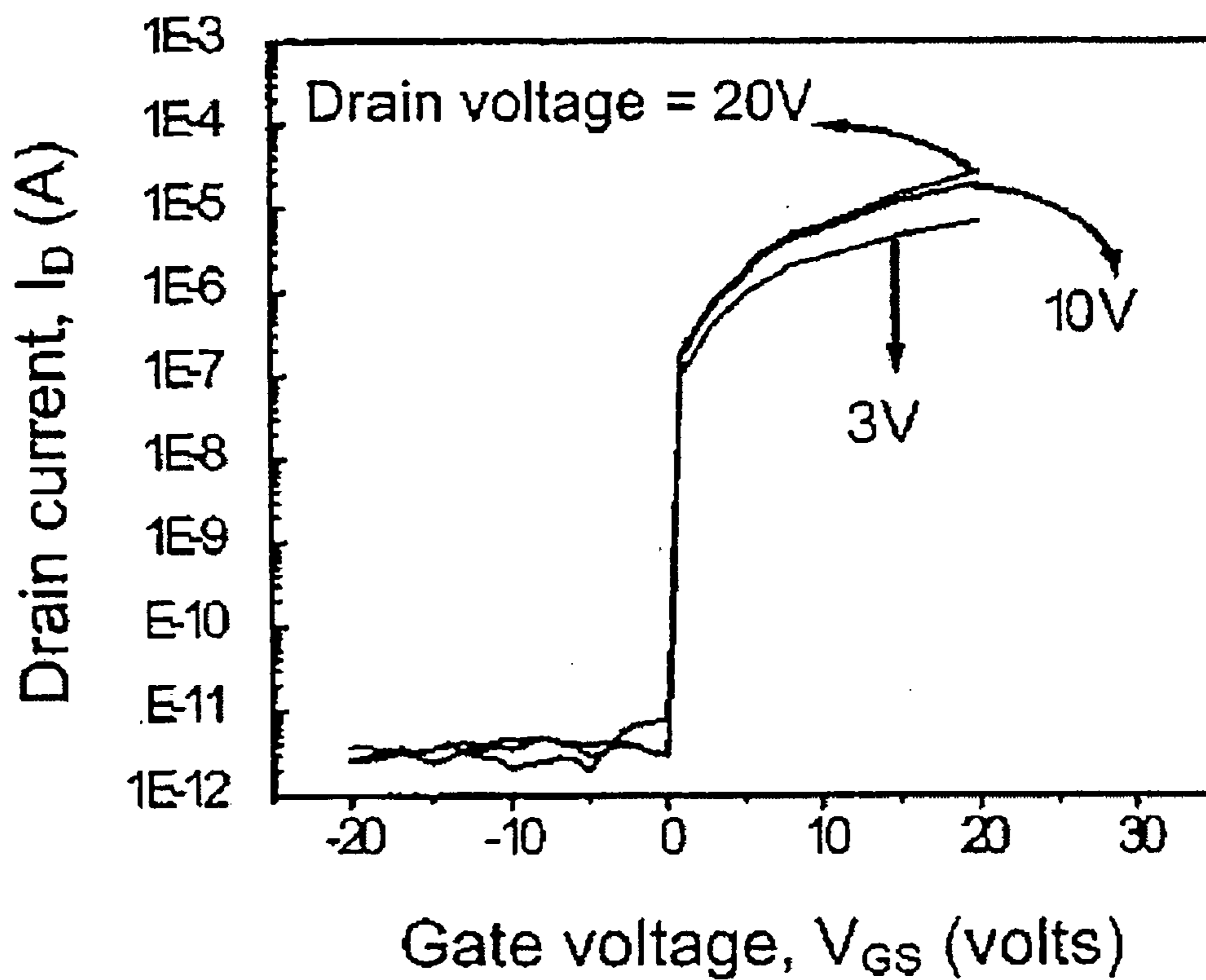

FIG. 3

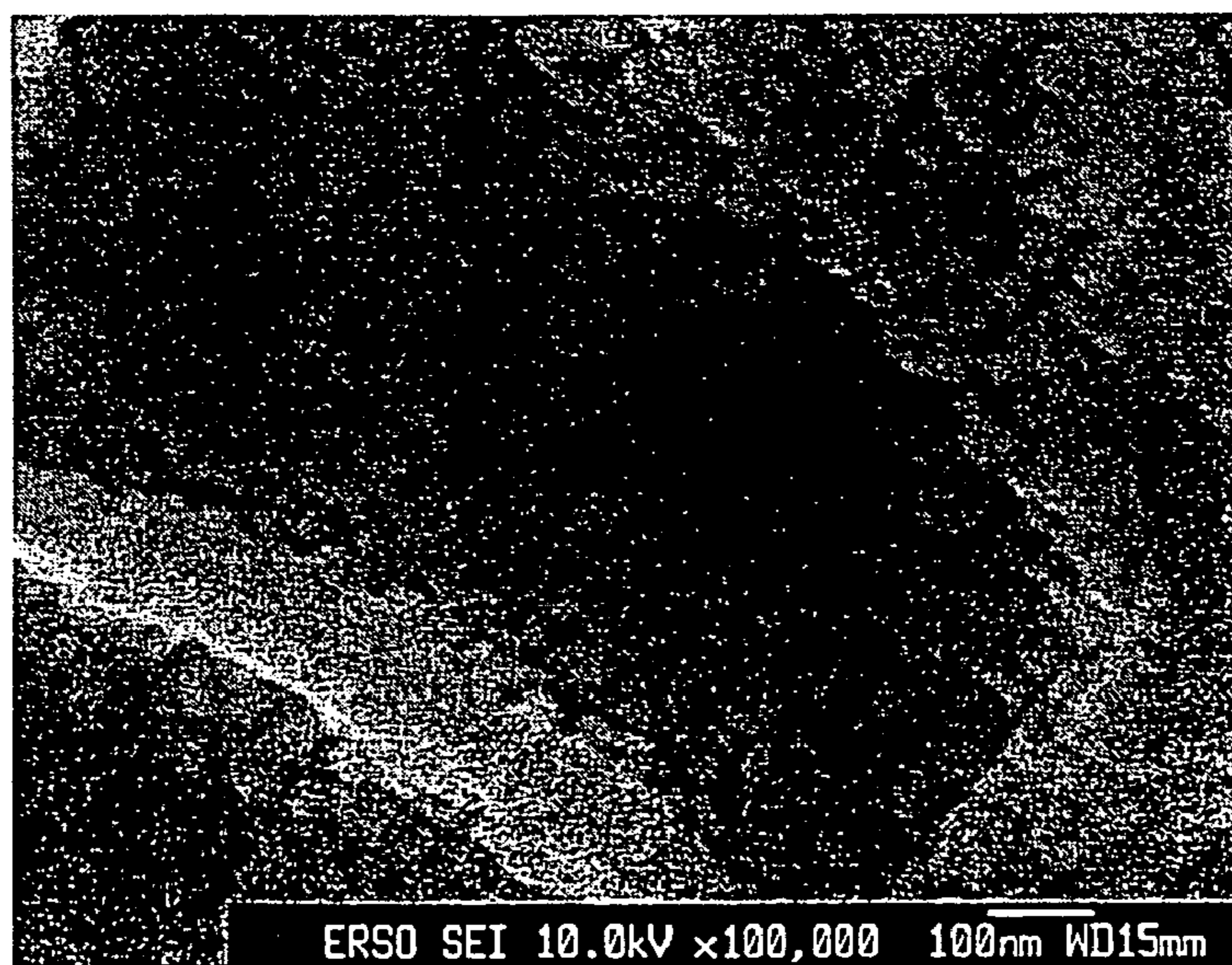

FIG. 4

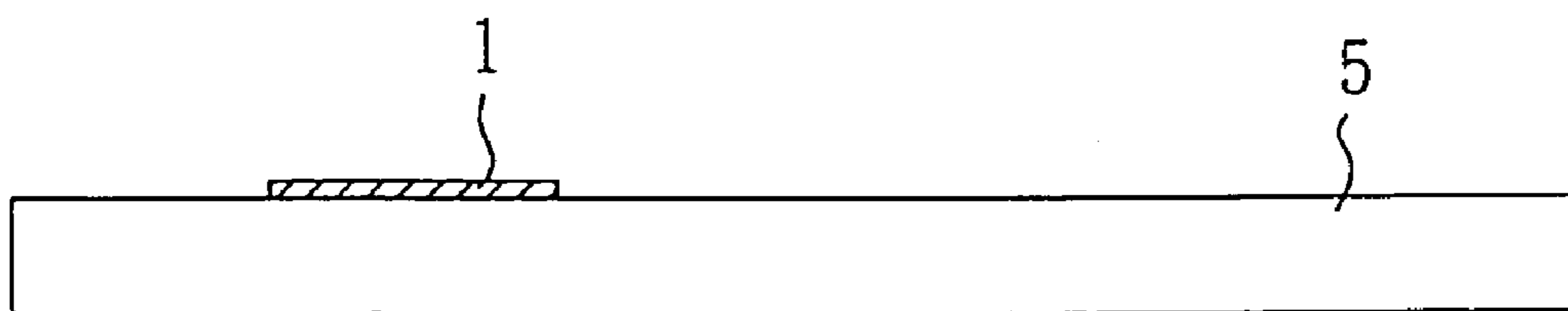

FIG. 5A

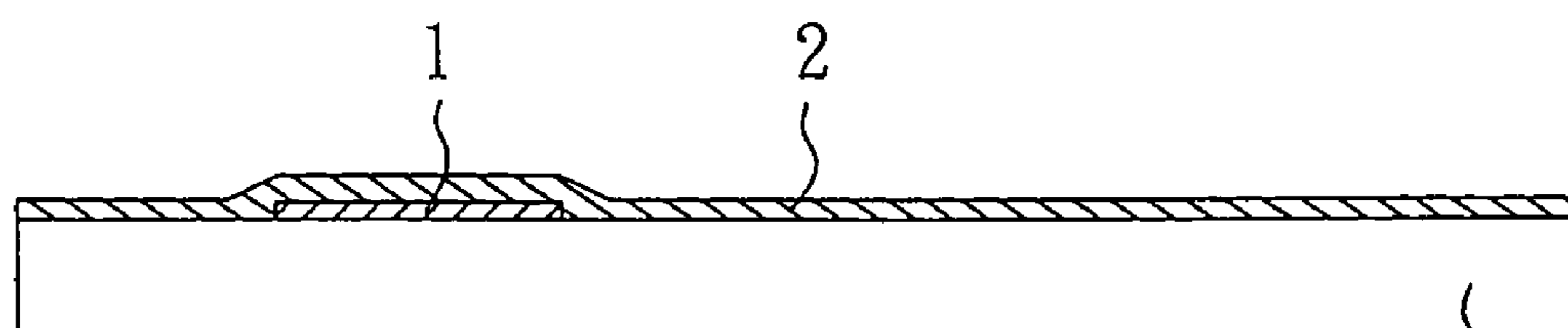

FIG. 5B

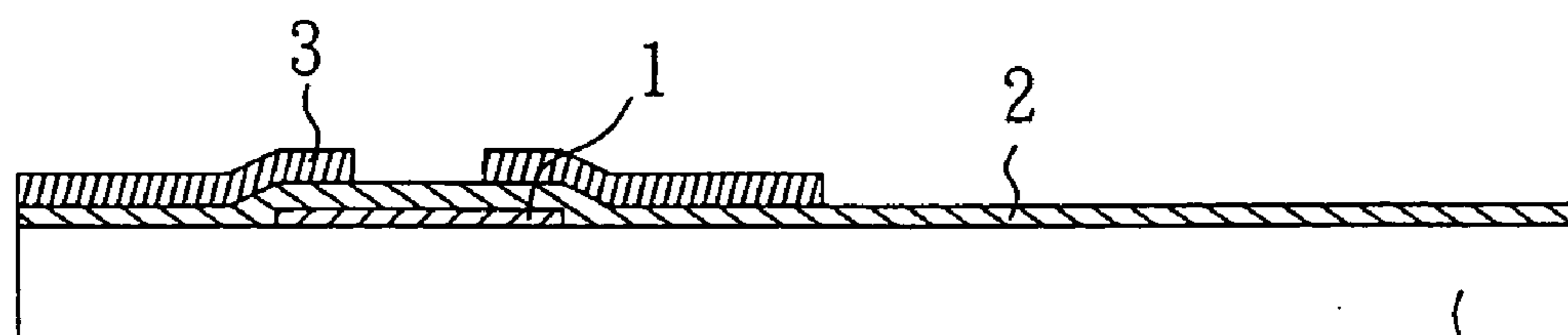

FIG. 5C

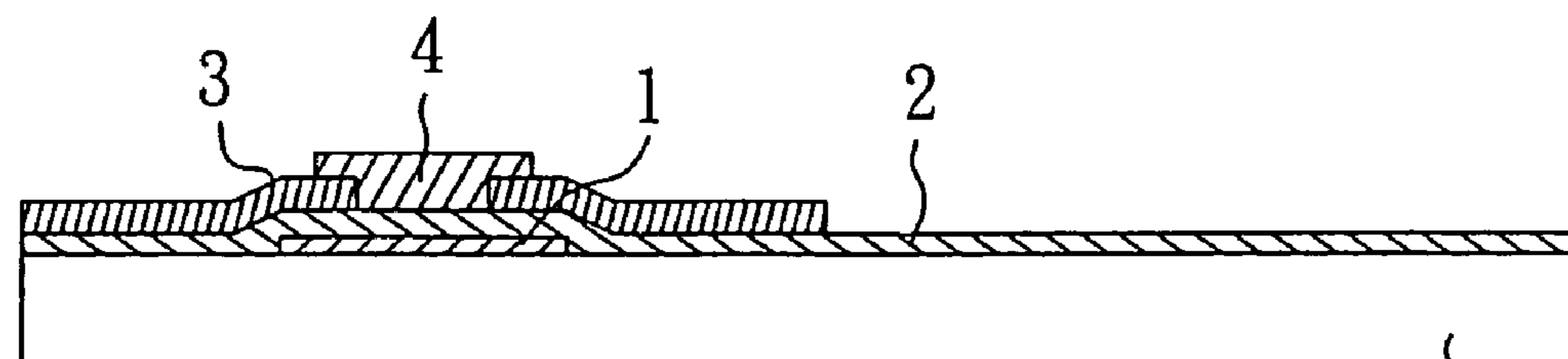

FIG. 5D

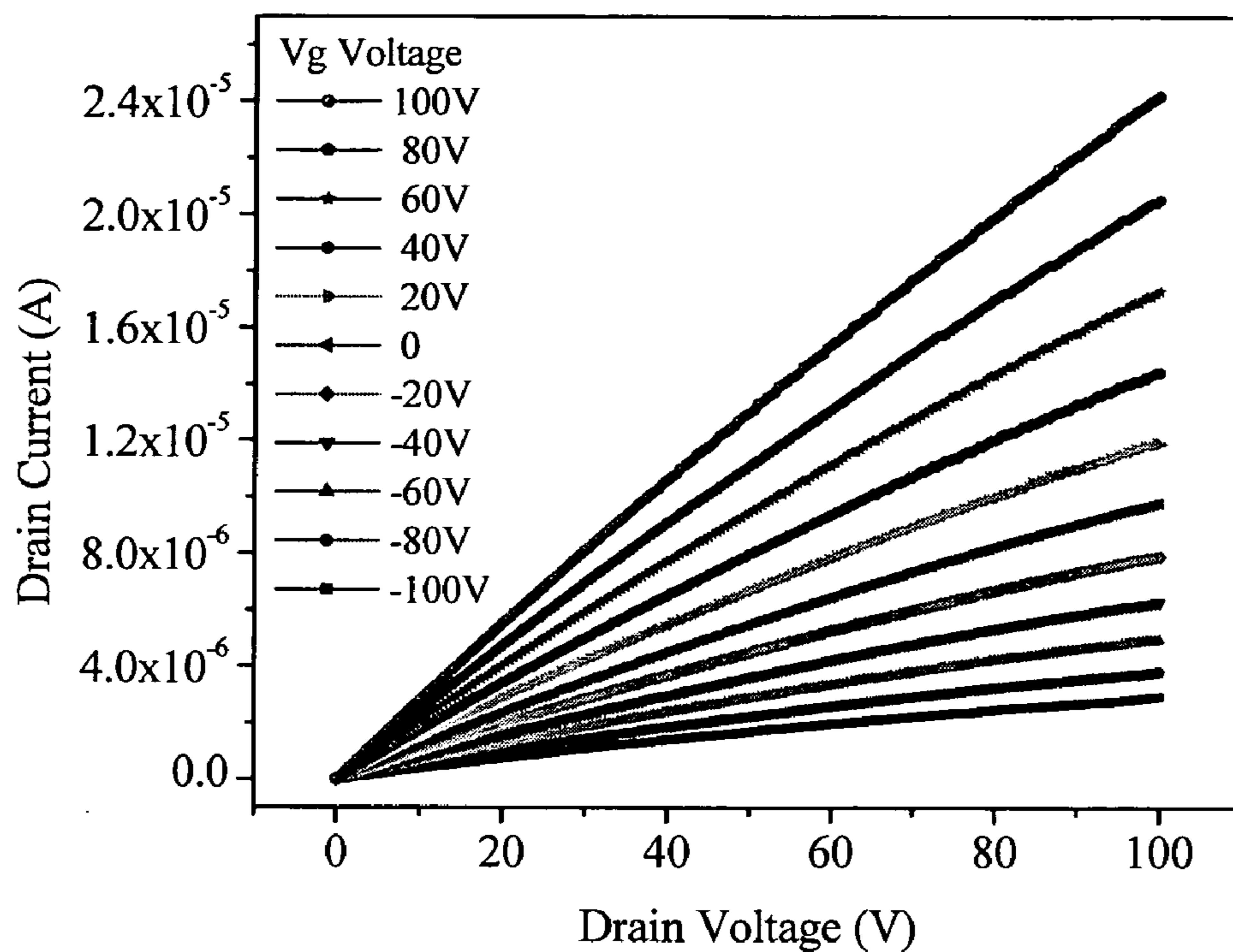

FIG. 6A

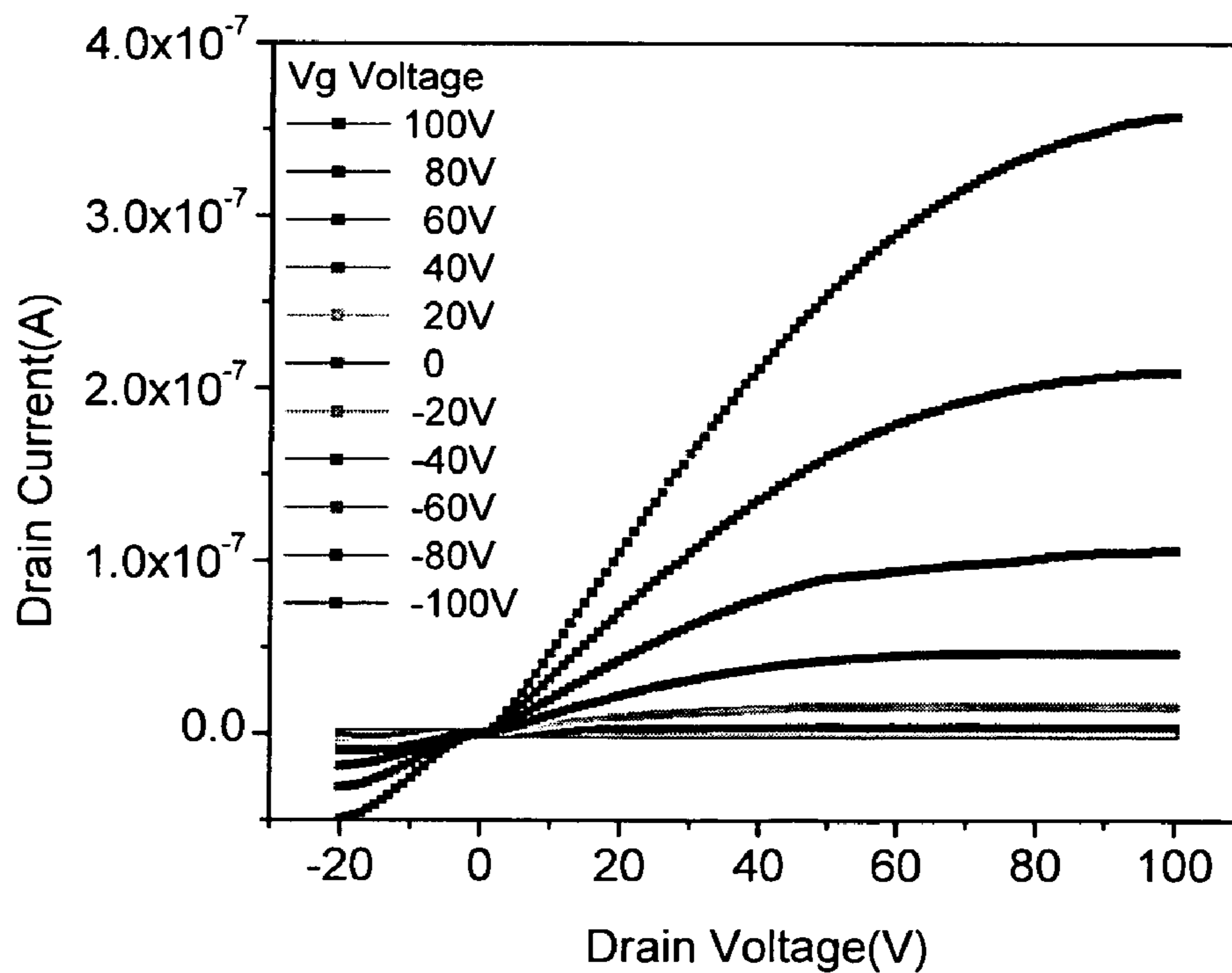

FIG. 6B

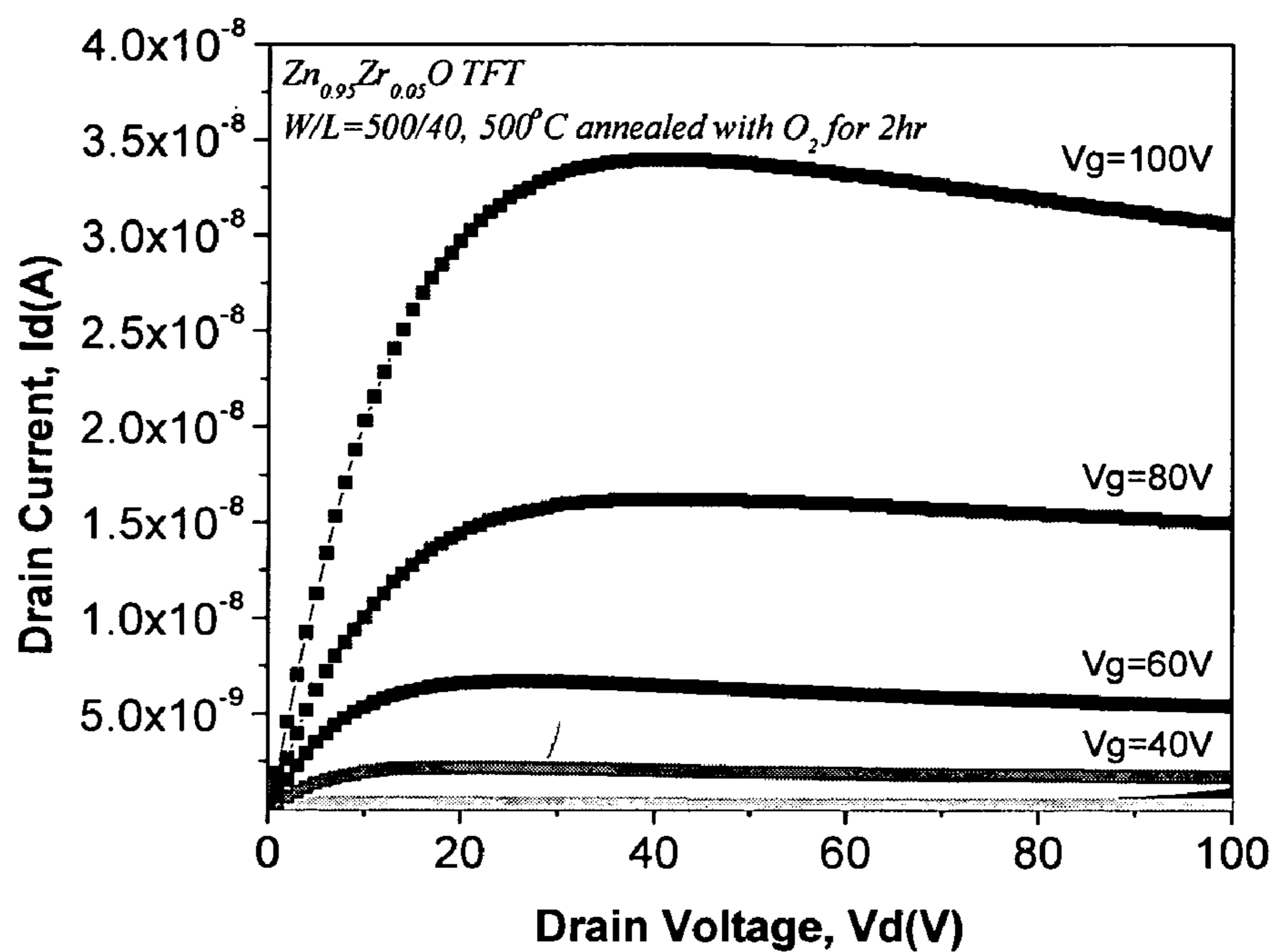

FIG. 7

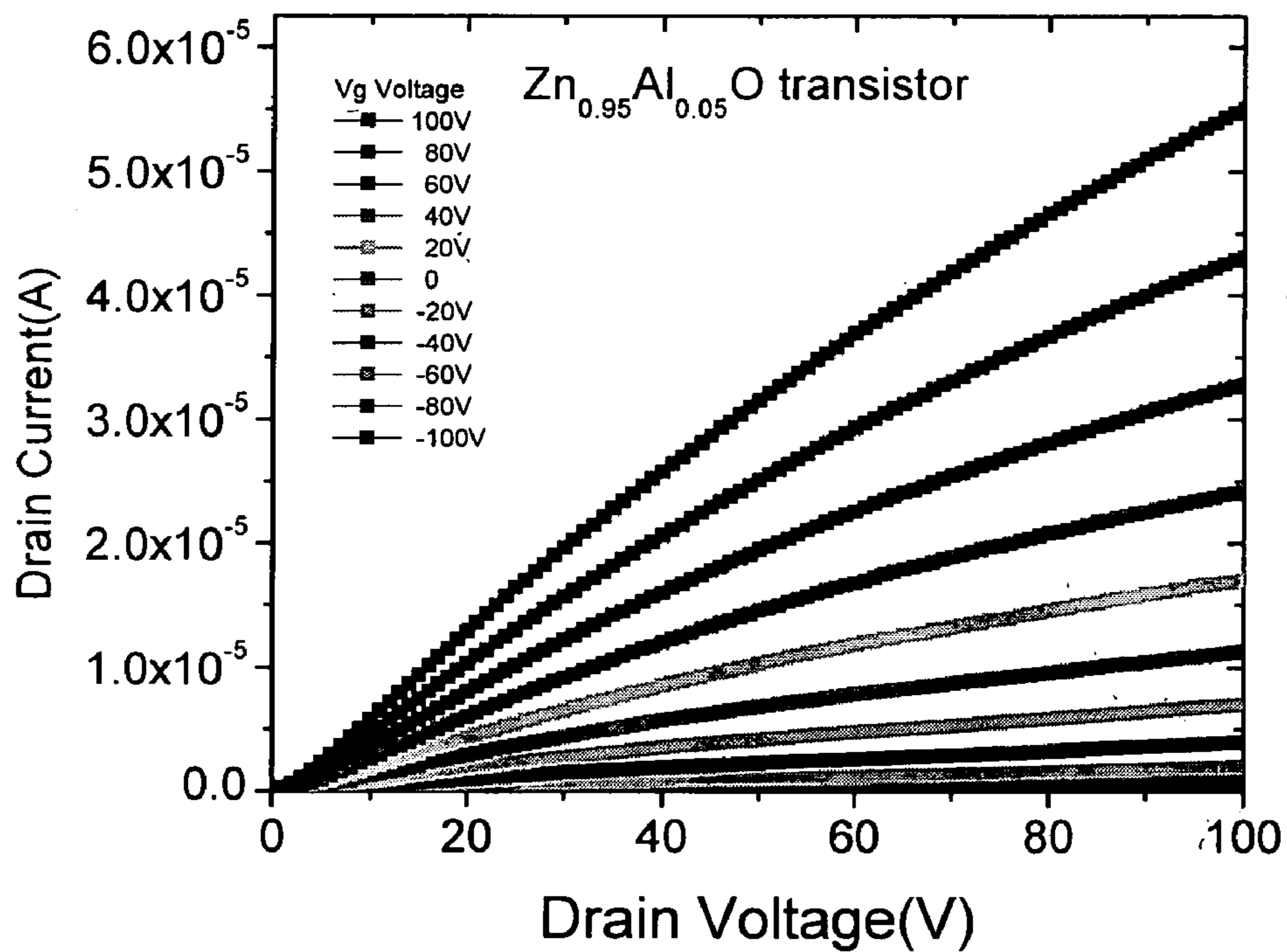

FIG. 8

**COMPOUND SEMICONDUCTOR MATERIAL  
AND METHOD FOR FORMING AN ACTIVE  
LAYER OF A THIN FILM TRANSISTOR  
DEVICE**

BACKGROUND OF THE INVENTION

**[0001]** 1. Field of the Invention

**[0002]** The present invention relates to a compound semiconductor material and, more particularly, to a compound semiconductor material suitable for forming the active layer of a thin film transistor of an active matrix flat panel display.

**[0003]** 2. Description of Related Art

**[0004]** Recently, the active matrix flat panel display has become a popular focus for research and development. In particular, the emphasis of that research and development is directed to the thin film transistor. In addition to that, the flat panel display has been developed to have a large active area, a low price, and a high resolution. Currently, the thin film transistors (TFTs) are classified as the amorphous silicon TFTs and the low temperature polycrystalline silicon TFTs, both of which need to undergo the vacuum evaporation process and the photolithography process, and thus have a high manufacturing cost. Lately, a method for manufacturing a thin film transistor using a group II-VI compound semiconductor by a solution process is disclosed. This method requires simple equipment, and has low cost and a fast processing speed.

**[0005]** However, take the manufacturing of ZnO transistors by the Sol-gel process for example. Although the Sol-gel process is simple and the materials used therein have a low toxicity, the characteristics of the transistors produced are not satisfactory. For instance, the current on/off ratio obtained is  $10^3$ , as shown in FIG. 1. Besides, there is research to manufacture a group II-VI compound, such as CdSe or CdS, transistors by a Chemical Bath Deposition (CBD) process. As shown in FIG. 2, the mobility of CdSe transistors reaches  $15 \text{ cm}^2/\text{Vs}$ , the current on/off ratio obtained is  $10^7$ , and the critical voltage is 3.5 V. Similarly, the mobility of CdS transistors reaches  $1 \text{ cm}^2/\text{Vs}$ , the current on/off ratio obtained is  $10^6$ , and the critical voltage is 2.6 V, as shown in FIG. 3. Although they both have good electrical characteristics, the precursors of CdSe and CdS are heavy metals that are quite toxic. Therefore, it is not feasible to mass-produce those transistors due to the problems of safety and environmental protection.

**[0006]** In the prior arts, the doped ZnO materials are mainly applied to the manufacturing of fluorescent films, and have not been used in the active layer of transistors yet. Therefore, it is desirable to provide a compound semiconductor material and a method for forming an active layer of a thin film transistor device to mitigate and/or obviate the aforementioned problems.

SUMMARY OF THE INVENTION

**[0007]** The object of the present invention is to provide a compound semiconductor material for forming an active layer of a thin film transistor device so that the transistors of an active matrix flat panel display are high voltage-durable and have improved device characteristics. Furthermore, the present invention uses the solution process to form the active layer but does not use vacuum evaporation, so it is easy to obtain a large area dispersion, to reduce the cost, and to preclude the toxic substances.

**[0008]** Another object of the present invention is to provide a method for forming an active layer of a thin film transistor device so that a large display area of the active matrix flat panel display is easily obtained, the manufacturing cost is reduced, no toxic substance is produced, and the manufacturing of the thin film transistor device benefits.

**[0009]** To achieve the object, the compound semiconductor material for forming an active layer of a thin film transistor device of the present invention includes a group II-VI compound doped with a dopant ranging from 0.1 to 30 mol %, wherein the dopant is selected from a group consisting of alkaline-earth metals, group IIIA elements, group IVA elements, group VA elements, group VIA elements, and transitional metals.

**[0010]** To achieve the object, the method for forming an active layer of a thin film transistor device of the present invention includes the steps of (a) providing a precursor solution of a compound semiconductor material; (b) patterning the precursor solution on a thin film transistor device to form an active layer; and (c) heating the precursor solution of the active layer on the thin film transistor device to evaporate the solvent in the precursor solution and to form a group II-VI compound layer doped with a dopant ranging from 0.1 to 30 mol %; wherein the dopant is selected from a group consisting of alkaline-earth metals, group IIIA elements, group IVA elements, group VA elements, group VIA elements, and transitional metals.

**[0011]** In the present invention, the precursor of the compound semiconductor materials, which are subsequently applied to form the active layer of a thin film transistor device, is prepared by a solution process. The compound semiconductor materials of the present invention have a group II-VI compound doped with an alkaline-earth metal, a group IIIA element, a group IVA element, a group VA element, a group VIA element, or a transitional metal, wherein the group II-VI compound is ZnO, ZnS, ZnSe, CdSe, CdS, HgS, MnS, SnS, PbS, CoS, NiS, or CdTe; the alkaline-earth metal is Mg, Ca, Sr, or Ba; the transitional metal is Sc, Ti, V, Cr, Mn, Fe, Co, Ni, Cu, Zn, Y, Zr, Nb, Mo, Tc, Ru, Rh, Pd, Ag, Cd, La, Hf, Ta, W, Re, Os, Ir, Pt, or Au; the group IIIA element is B, Al, Ga, In, or Tl; the group IVA element is Si, Ge, Sn, or Pb; the group VA element is N, P, As, Sb, or Bi; and the group VIA element is S, Se, Te, or Po.

**[0012]** The solution process for preparing the precursor of the compound semiconductor materials of the present invention can be Chemical Bath Deposition, Photochemical Deposition, or Sol-gel process. Next, the active layer of the thin film transistor is patterned through Inkjet Printing, Nanoimprinting, Micro Contact Printing, or a spin coating-photolithography process. The structure of the thin film transistor can be any conventional structure. Preferably, the structure is a bottom gate structure, top gate structure, or side gate structure. The thin film transistor includes a gate electrode, a source electrode, a drain electrode, a dielectric layer, and a substrate. Preferably, the gate electrode, the source electrode, or the drain electrode of the thin film transistor device is made of metals, electrically conductive oxides, or electrically conductive polymers. Preferably, the dielectric constant of the dielectric layer is more than 3. More preferably, the dielectric layer is made of inorganic materials, polymers, or the material having a high dielectric constant. Preferably, the substrate is a silicon wafer, a glass substrate, a quartz substrate, a plastic substrate, or a flexible substrate.

**[0013]** The present invention provides a new compound semiconductor material, which forms the active layer of a thin film transistor by using the solution process. The thin film transistor is thus durable for high voltage operation and has optimum characteristics. Moreover, the compound semiconductor materials of the present invention are suitable for manufacturing the large size active matrix flat panel display because no vacuum evaporation is needed and the manufacturing cost is therefore reduced relative to prior art. In addition to that, the precursor formed in the solution process is not toxic, so there is no concern about the safety and protection of the operational environment.

**[0014]** Other objects, advantages, and novel features of the invention will become more apparent from the following detailed description when taken in conjunction with the accompanying drawings.

#### BRIEF DESCRIPTION OF THE DRAWINGS

**[0015]** FIG. 1 shows the relation curve of gate voltage and drain current of a ZnO transistor in prior arts;

**[0016]** FIG. 2 shows the relation curve of gate voltage and drain current of a CdSe transistor in prior arts;

**[0017]** FIG. 3 shows the relation curve of gate voltage and drain current of a CdS transistor in prior arts;

**[0018]** FIG. 4 is the SEM picture of the Mg-doped ZnO compound semiconductor material of one preferred embodiment of the present invention;

**[0019]** FIGS. 5A-5D show the process flow for manufacturing a thin film transistor of one preferred embodiment of the present invention;

**[0020]** FIG. 6A shows the relationship between the drain voltage (Vd) and the drain current (Id) of a ZnO transistor in the prior arts;

**[0021]** FIG. 6B shows the relationship between the drain voltage (Vd) and the drain current (Id) of a Zn(0.8)Mg(0.2)O transistor of one preferred embodiment of the present invention;

**[0022]** FIG. 7 shows the relationship between the drain voltage (Vd) and the drain current (Id) of a Zr-doped ZnO transistor of another preferred embodiment of the present invention; and

**[0023]** FIG. 8 shows the relationship between the drain voltage (Vd) and the drain current (Id) of an Al-doped ZnO transistor of the other preferred embodiment of the present invention.

#### DETAILED DESCRIPTION OF THE PREFERRED EMBODIMENT

##### Embodiment 1

**[0024]** In the solution process, all of the oxides of group II-VI compounds can use 2-methoxy-ethanol or other alcohols as the solvent. When choosing the solvent, the factors concerned are the solubility of a solute, the ability for film formation of the solution, the removing of the solvent, and the growth of the grain.

**[0025]** In the present embodiment, ZnO is doped with Mg to form a compound semiconductor material. First, 100 ml of solvent, i.e. 2-Methoxy-ethanol is mixed with 4.58 g of monoethanol amine. Then, 0.06 mole of zinc acetate and 0.015 mole of MgCl<sub>2</sub> are further added into the solvent and stirred at 60 degrees C. for 30 minutes to prepare a precursor solution of Zn(0.8)Mg(0.2)O. Afterwards, the precursor solution is coated at the channels of the transistors by Inkjet

Printing. Finally, the precursor solution coated at the channels of the transistors is annealed at 500 degrees C. for 2 hours in an oven. With reference to FIG. 4, the SEM picture shows that the grain size of the Mg-doped ZnO is about 20 nm.

##### Embodiment 2

**[0026]** With reference to FIGS. 5A-5D, the process flow for manufacturing a thin film transistor is shown, wherein the bottom gate of the thin film transistor is formed with the compound semiconductor material of the present invention. As shown in FIG. 5A, a glass substrate 5 is provided, and then a first electrode layer is formed thereon. The first electrode layer is made of electrically conductive material, such as ITO, Cr, Al, Mo, Au, Pt, Ag, etc. Next, the first electrode layer is patterned by photolithography and etching processes and a gate electrode 1 is formed. As shown in FIG. 5B, an insulating layer 2 is subsequently deposited on the gate electrode 1. The insulating layer 2 can be made of silicon oxides, silicon nitrides, or PZT. The insulating layer 2 can be deposited by any conventional method. Preferably, the insulating layer 2 is deposited by physical vapor deposition or chemical vapor deposition. As shown in FIG. 5C, a second electrode layer 3 is formed by sputtering. The second electrode layer can be made of ITO, Cr, Al, Mo, Au, Pt, or Ag. Afterwards, the second electrode layer is patterned to form the source electrode and drain electrode 3. As shown in FIG. 5D, the precursor solution prepared by a solution process, such as Chemical Bath Deposition, Photochemical Deposition, or Sol-gel process, of the present invention is used to form the active layer 4. The active layer 4 can be formed and patterned by Inkjet Printing, Nanoimprinting, Micro Contact Printing, or a spin coating-photolithography process. After being heated, the active layer 4 having a group II-VI compound doped with an alkaline-earth metal, a group IIIA element, a group IVA element, a group VA element, a group VIA element, or a transitional metal is obtained.

**[0027]** FIGS. 6A and 6B show the relationship between the drain voltage (Vd) and the drain current (Id) of the transistors having ZnO and Zn(0.8)Mg(0.2)O active layer, respectively. When ZnO is not doped, the characteristic curve of Id to Vd is nearly linear, which reveals that the characteristics of ZnO are similar to that of a resistor. Furthermore, the leakage current Id is around 10<sup>-6</sup> A when the voltage of gate electrode is -100 V and the voltage of drain electrode is 100 V. On the other hand, when ZnO is doped with 20% of the alkaline-earth metal, i.e. Mg, the characteristic curve of Id vs. Vd tends to be similar with that of semiconductors. In particular, the leakage current Id is around 10<sup>-11</sup> A when the voltage of gate electrode is -100 V and the voltage of drain electrode is 100V. Besides, the current on/off ratio of the transistor is 10<sup>4</sup>, and its mobility is 5×10<sup>-4</sup> cm<sup>2</sup>/Vs. From the experimental results, it is obvious that the Mg-doped ZnO reduces the off current from 4 μA to 20 μA.

**[0028]** In addition to Mg, Al and Zr also can improve the characteristics of the transistor. When ZnO is doped with Zr, the off current drops to 1 pA, as shown in FIG. 7. Similarly, when ZnO is doped with Al, the on current increases from 25 μA to 60 μA, as shown in FIG. 8.

**[0029]** Although the present invention has been explained in relation to its preferred embodiment, it is to be understood that many other possible modifications and variations can be made without departing from the spirit and scope of the invention as hereinafter claimed.



**1-15.** (canceled)

**16.** A thin film transistor device comprising:

a substrate;

a gate electrode deposited on the substrate;

a dielectric layer deposited on the gate electrode;

a source electrode and a drain electrode deposited on the dielectric layer; and

an active layer deposited on the gate electrode and source electrode, wherein the active layer comprises a group II-VI compound doped with a dopant ranging from 0.1 to 30 mol % and wherein the dopant is selected from a group consisting of at least one of alkaline-earth metals, group IIIA elements, group IVA elements, group VA elements, group VIA elements, and transitional metals.

**17.** The thin film transistor device of claim **16**, wherein the group II-VI compound is ZnO, ZnS, ZnSe, CdSe, CdS, HgS, MnS, SnS, PbS, CoS, NiS, or CdTe.

**18.** The thin film transistor device of claim **16**, wherein the alkaline-earth metal is Mg, Ca, Sr, or Ba; the transitional metal is Sc, Ti, V, Cr, Mn, Fe, Co, Ni, Cu, Zn, Y, Zr, Nb, Mo, Tc, Ru, Rh, Pd, Ag, Cd, La, Hf, Ta, W, Re, Os, Ir, Pt, or Au; the group IIIA element is B, Al, Ga, In, or Tl; the group IVA

element is Si, Ge, Sn, or Pb; the group VA element is N, P, As, Sb, or Bi; and the group VIA element is S, Se, Te, or Po.

**19.** The thin film transistor device of claim **17**, wherein the alkaline-earth metal is Mg, Ca, Sr, or Ba; the transitional metal is Sc, Ti, V, Cr, Mn, Fe, Co, Ni, Cu, Zn, Y, Zr, Nb, Mo, Tc, Ru, Rh, Pd, Ag, Cd, La, Hf, Ta, W, Re, Os, Ir, Pt, or Au; the group IIIA element is B, Al, Ga, In, or Tl; the group IVA element is Si, Ge, Sn, or Pb; the group VA element is N, P, As, Sb, or Bi; and the group VIA element is S, Se, Te, or Po. The thin film transistor device of claim

**20.** The thin film transistor device of claim **16**, wherein the active layer is a ZnO compound doped with a Mg compound.

**21.** The thin film transistor device of claim **20**, wherein the Mg ZnO compound has a grain size of about 20 nm.

**22.** The thin film transistor device of claim **17** wherein the ZnO is doped with Al or Zr.

**23.** The thin film transistor device as claimed in claim **16**, wherein a precursor solution containing components of the active layer is prepared by Chemical Bath Deposition, Photochemical Deposition, or Sol-gel process to produce the active layer.

\* \* \* \* \*