



US 20080241903A1

(19) **United States**

(12) **Patent Application Publication**
Schultz et al.

(10) **Pub. No.: US 2008/0241903 A1**

(43) **Pub. Date: Oct. 2, 2008**

(54) **IN VIVO SITE-SPECIFIC INCORPORATION OF N-ACETYL-GALACTOSAMINE AMINO ACIDS IN EUBACTERIA**

(75) Inventors: **Peter G. Schultz**, La Jolla, CA (US); **Sarah R. Hanson**, San Marcos, CA (US); **Ran Xu**, Houston, TX (US); **Zhiwen Zhang**, Palo Alto, CA (US); **Chi-Huey Wong**, Santa Fe, CA (US)

Correspondence Address:
QUINE INTELLECTUAL PROPERTY LAW GROUP, P.C.
P O BOX 458
ALAMEDA, CA 94501 (US)

(73) Assignee: **The Scripps Research Institute**, La Jolla, CA (US)

(21) Appl. No.: **12/082,214**

(22) Filed: **Apr. 8, 2008**

Related U.S. Application Data

(62) Division of application No. 11/255,601, filed on Oct. 20, 2005, now Pat. No. 7,378,263.

(60) Provisional application No. 60/620,898, filed on Oct. 20, 2004.

Publication Classification

(51) **Int. Cl.**
C12N 9/00 (2006.01)

C12N 5/06 (2006.01)

(52) **U.S. Cl.** **435/183; 435/325**

(57) **ABSTRACT**

Methods and compositions for making glycoproteins, both in vitro and in vivo, are provided. One method involves incorporating an unnatural amino acid having a N-acetylgalactosamine moiety into a protein; optionally, the N-acetylgalactosamine-containing unnatural amino acid can be further modified with additional sugars.

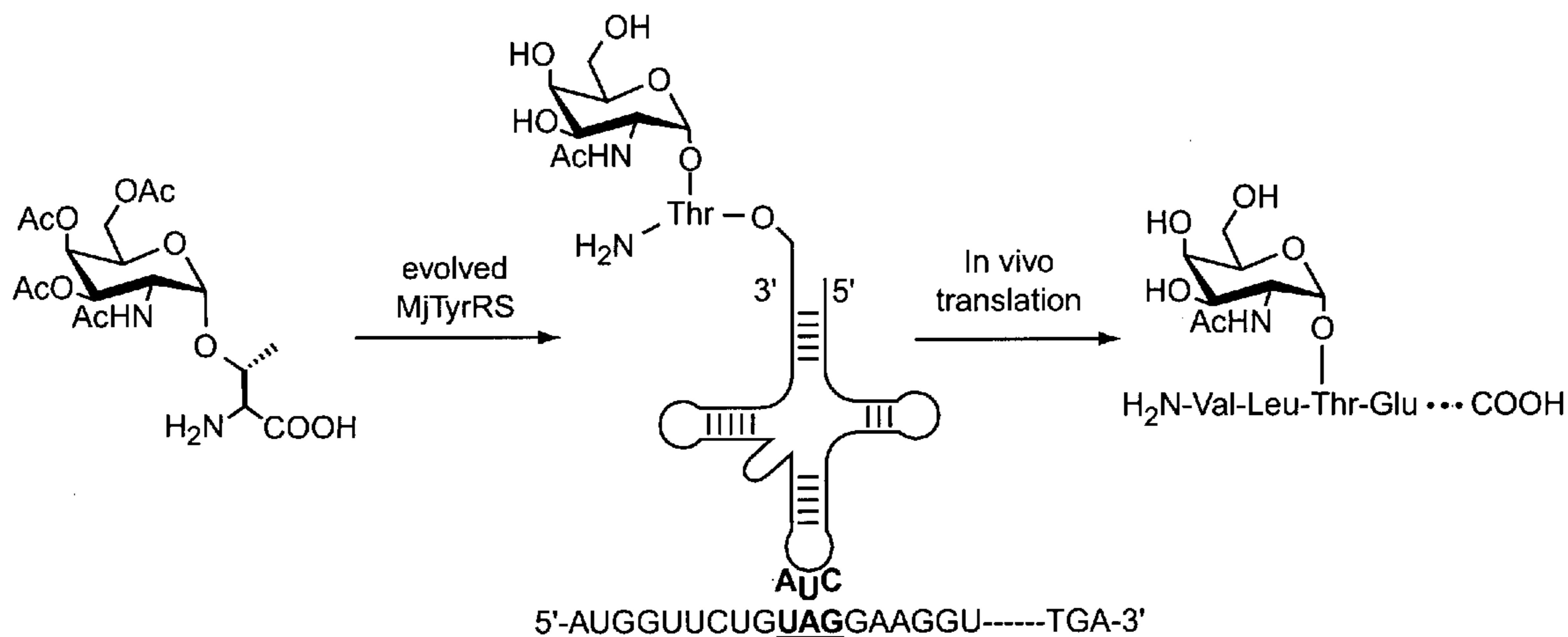

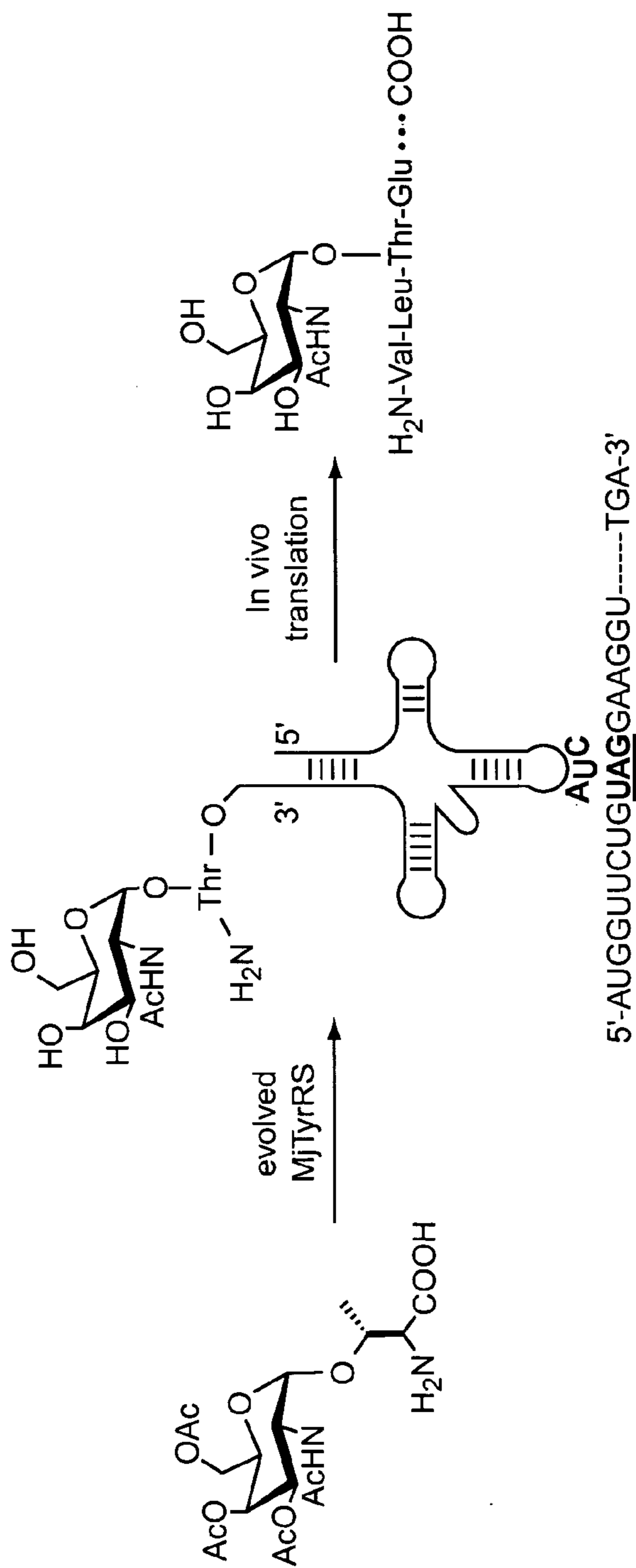

Fig. 1

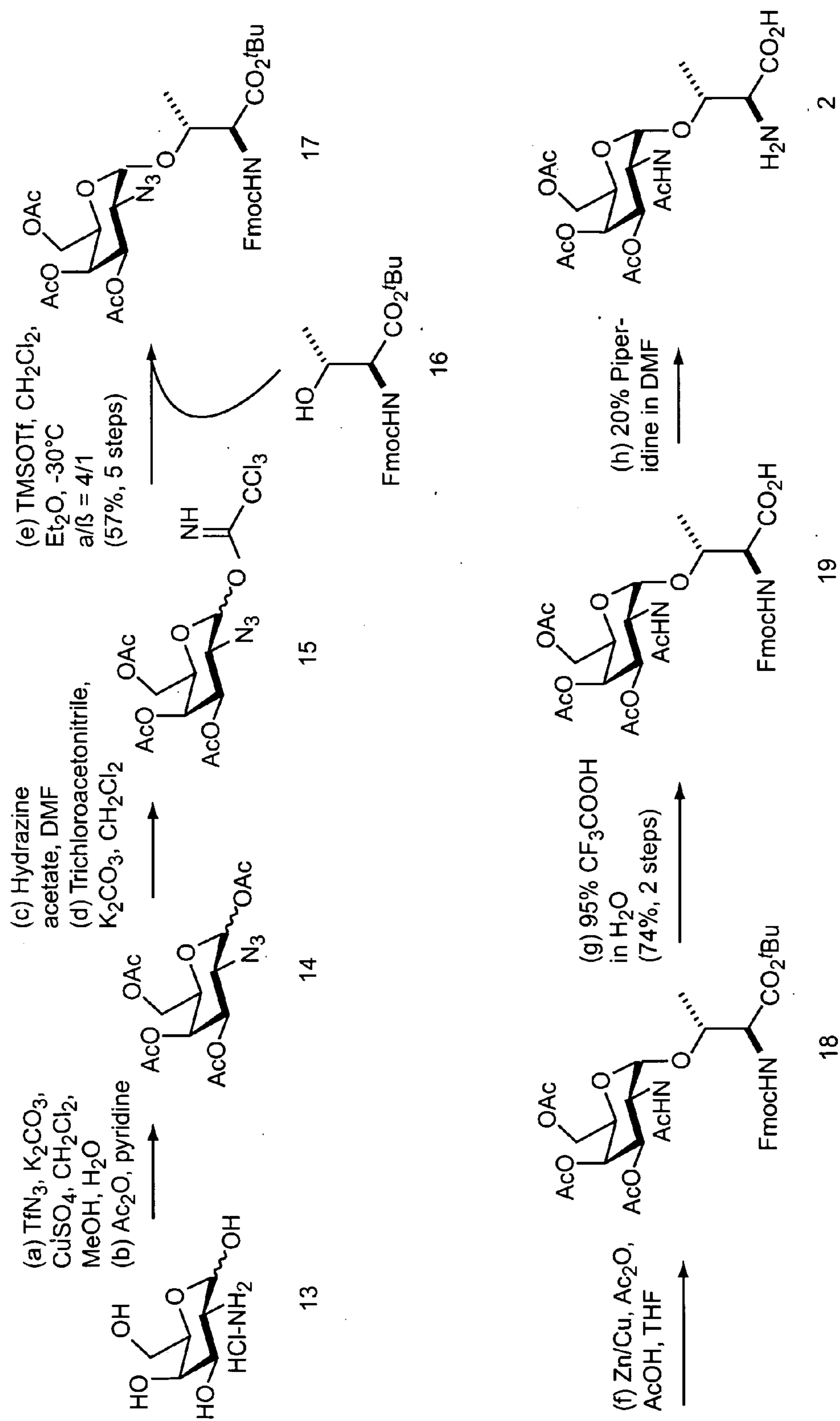

Fig. 2

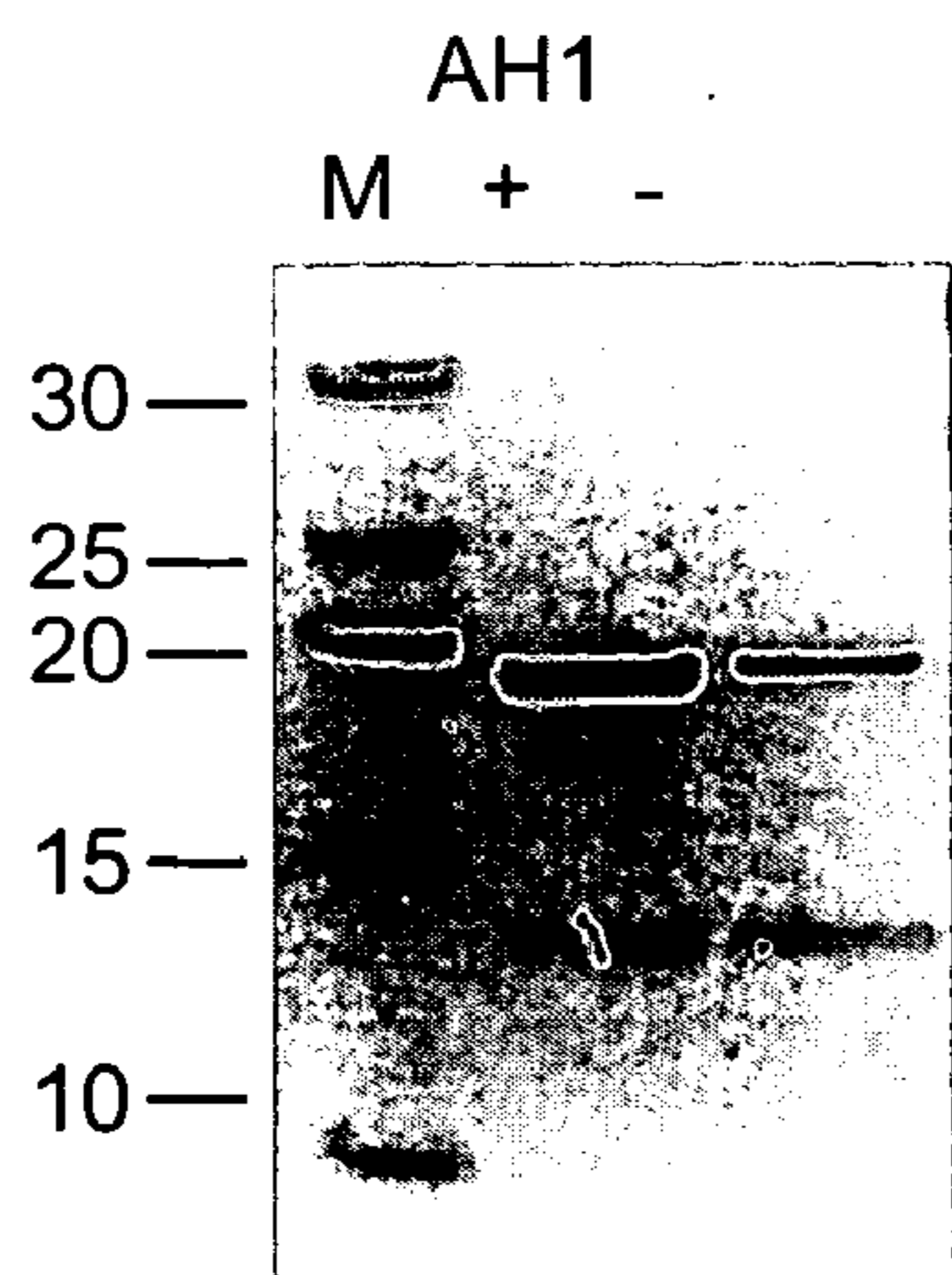

Fig. 3A

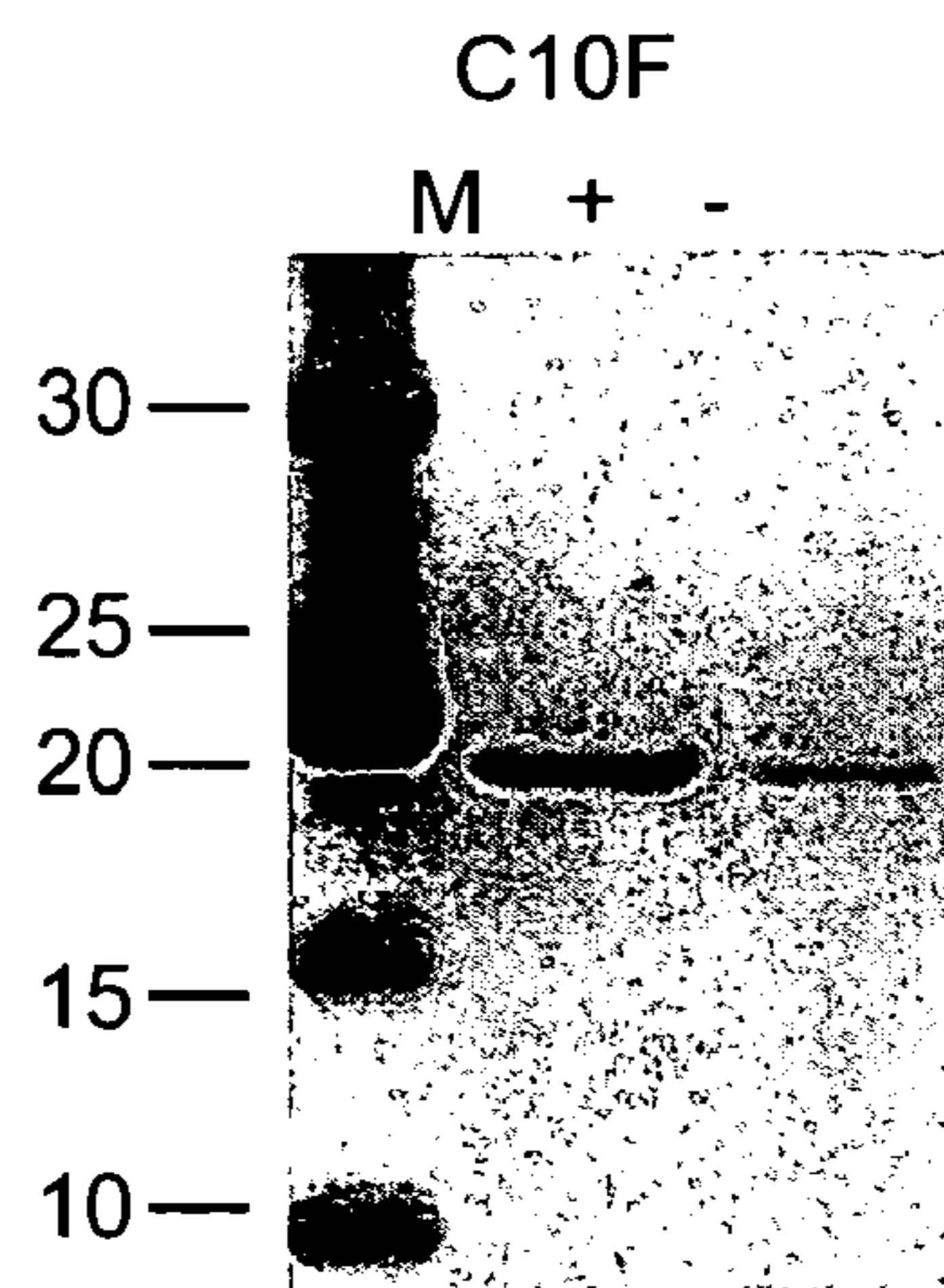

Fig. 3B

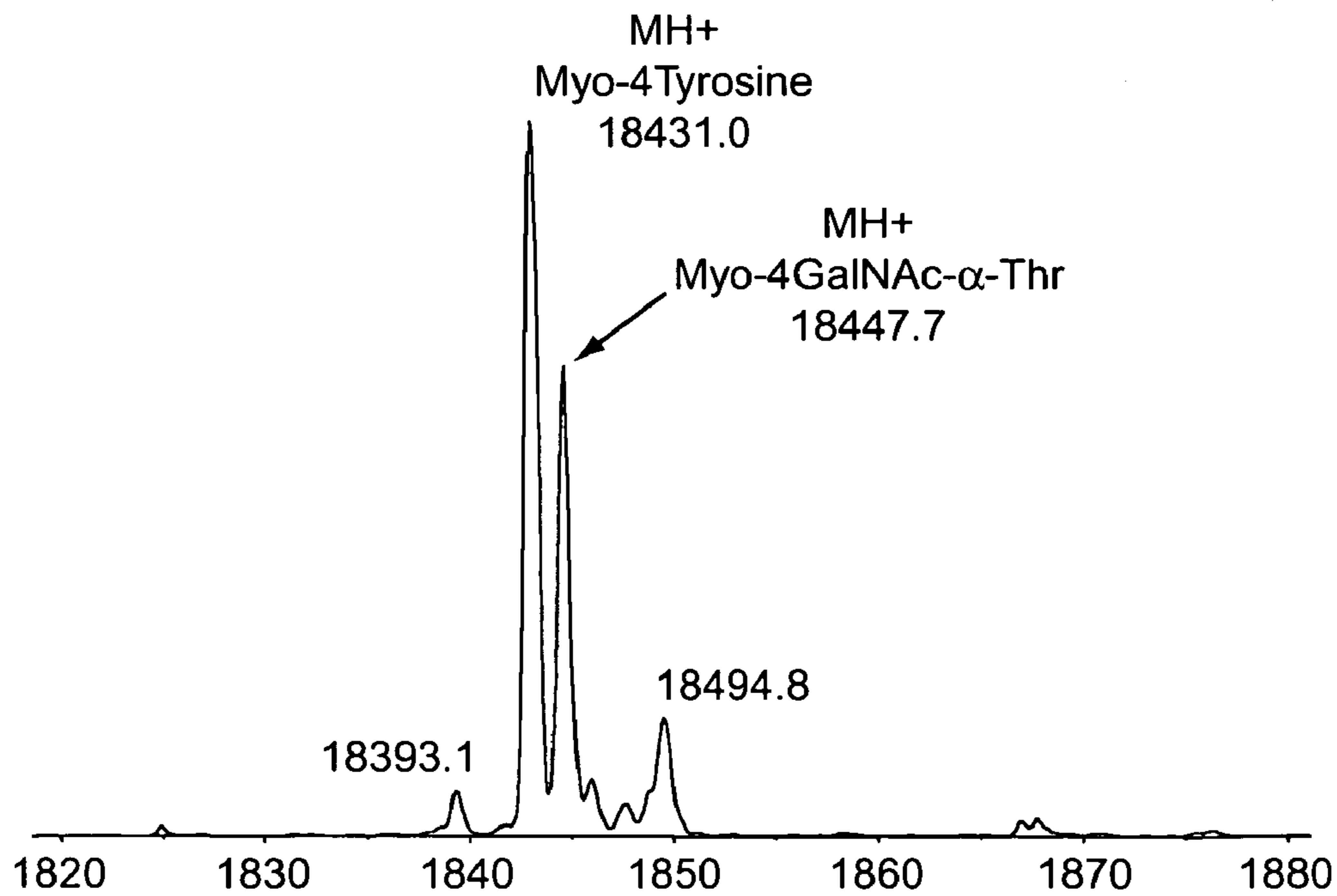

Fig. 3C

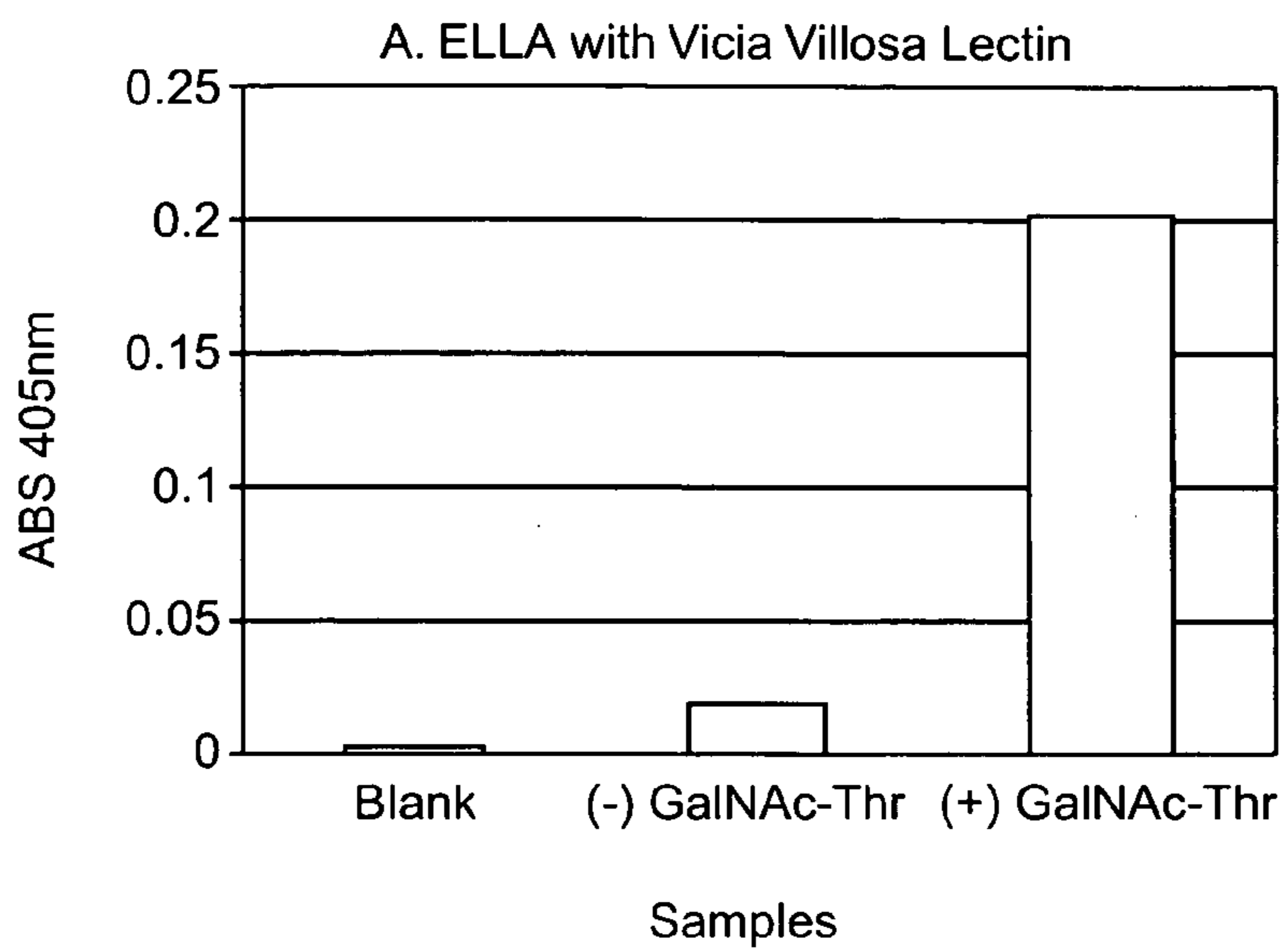

Fig. 4A

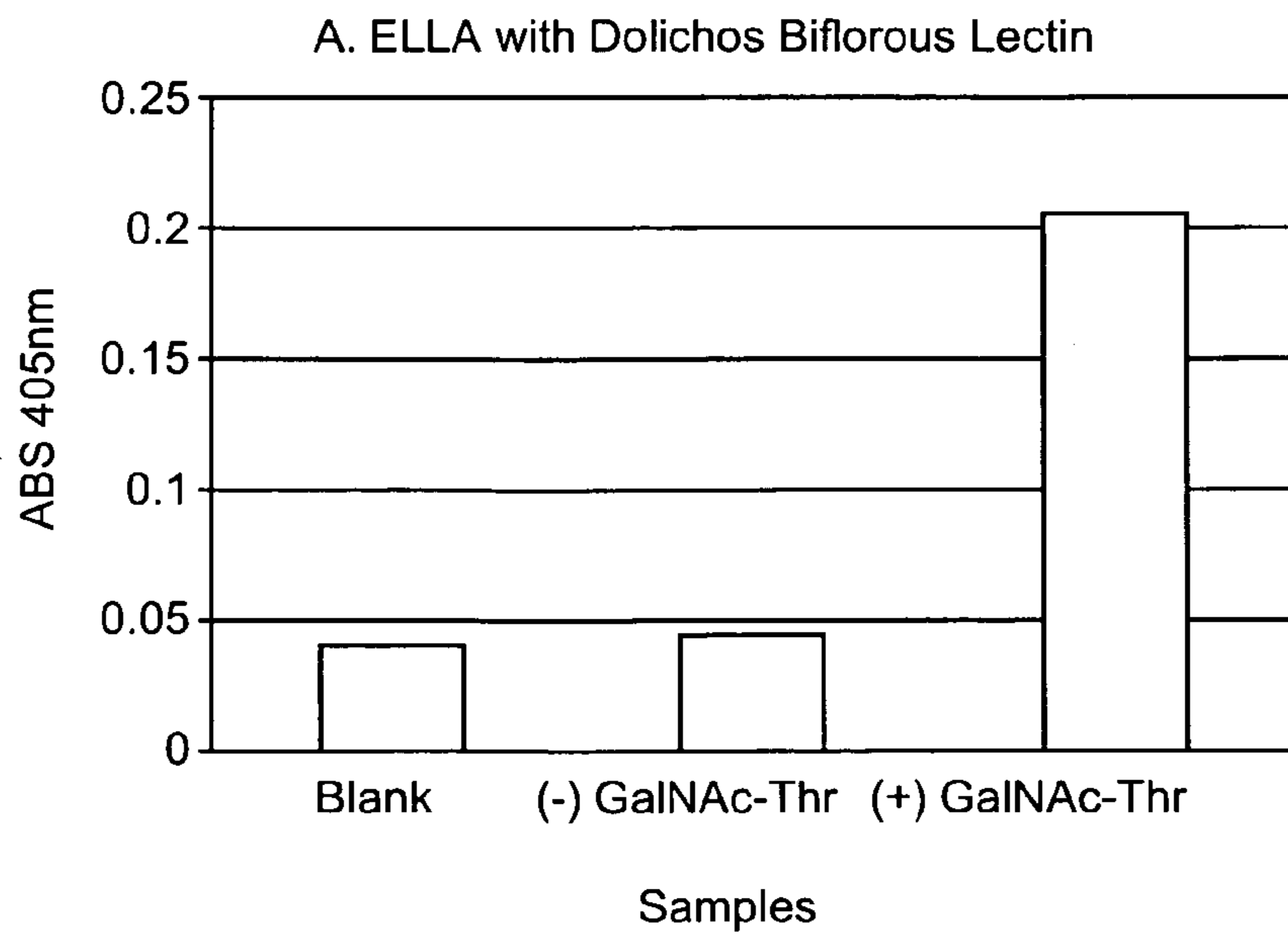

Fig. 4B

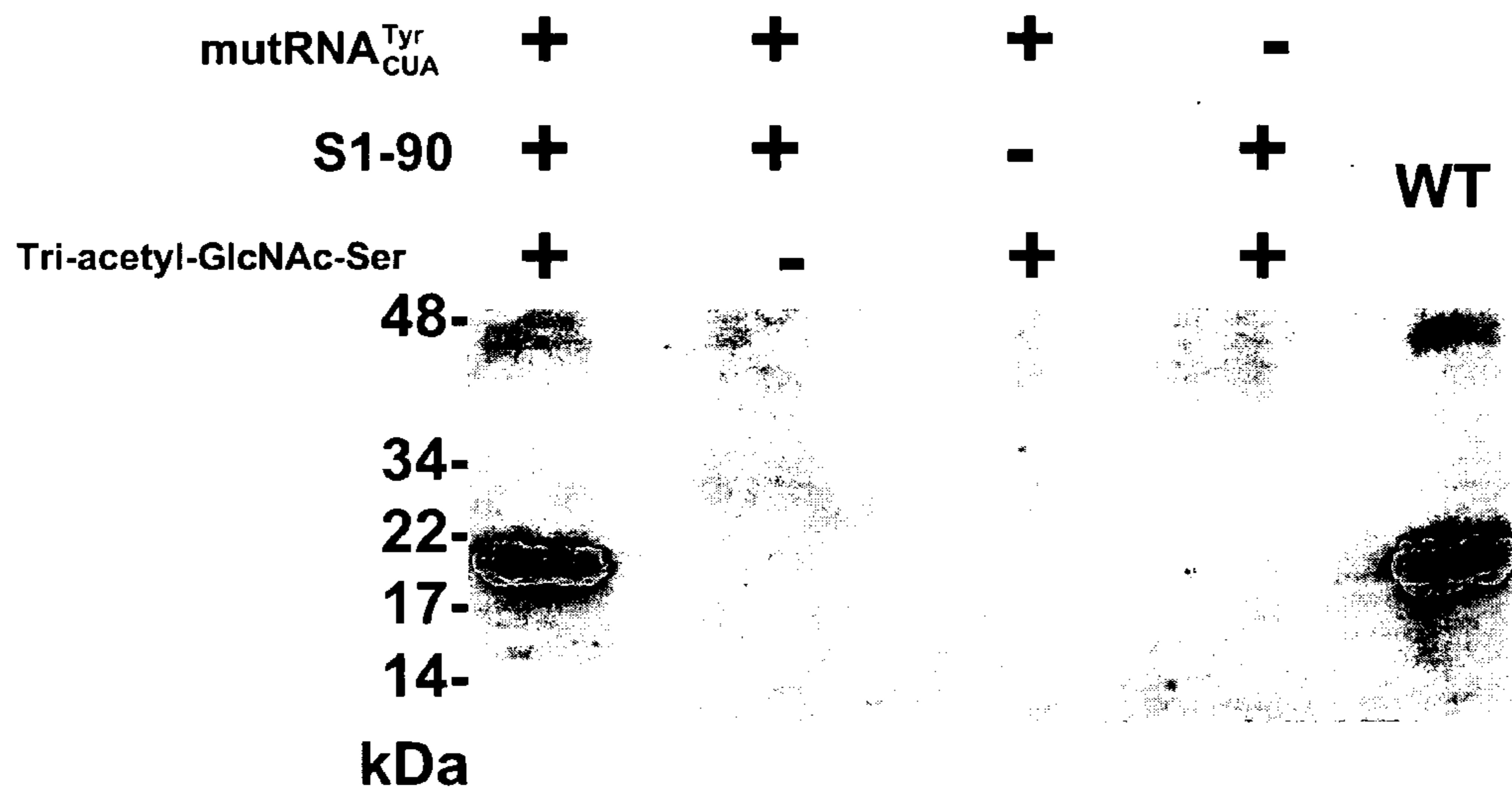

Fig. 5A

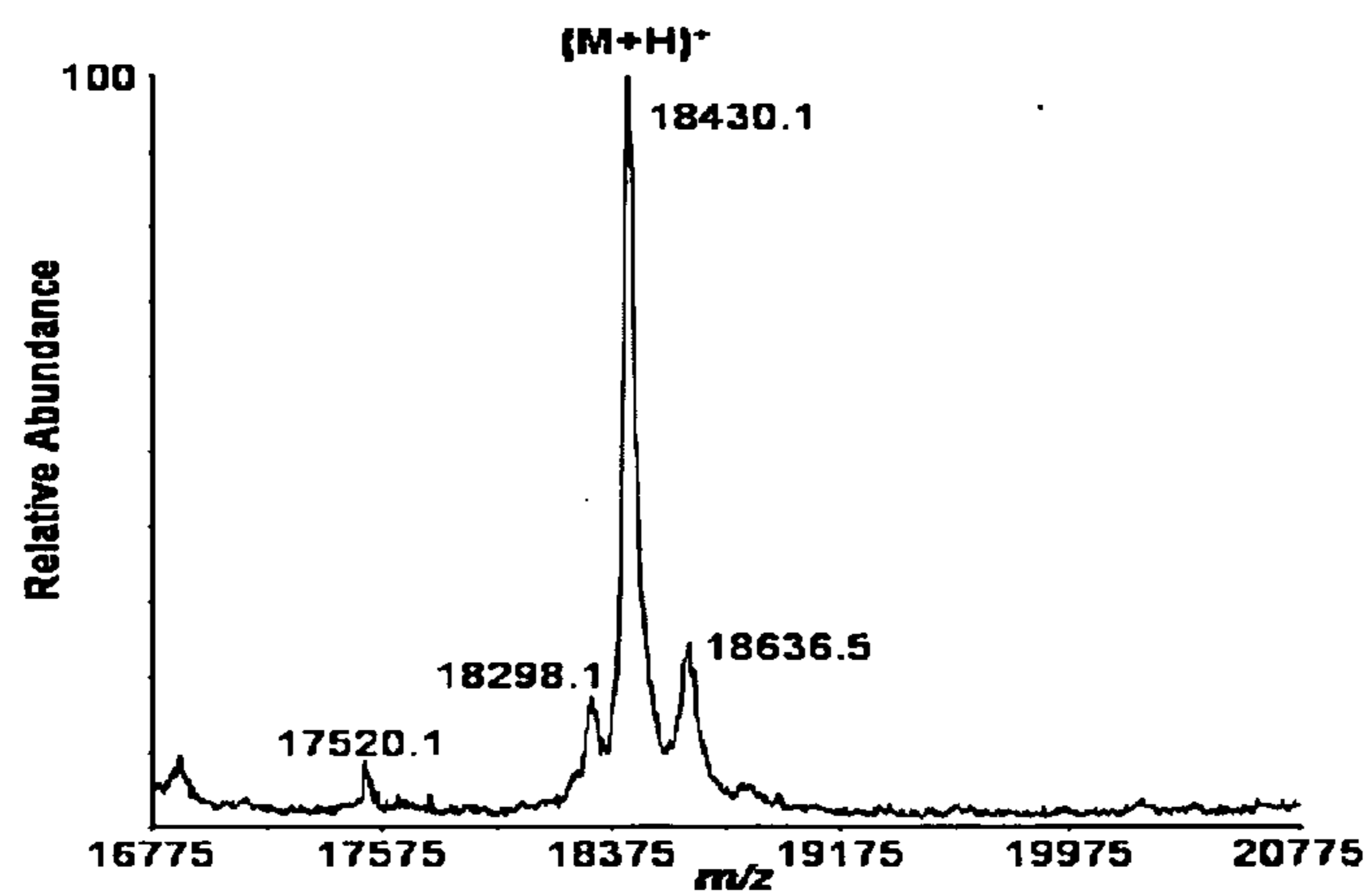

Fig. 5B

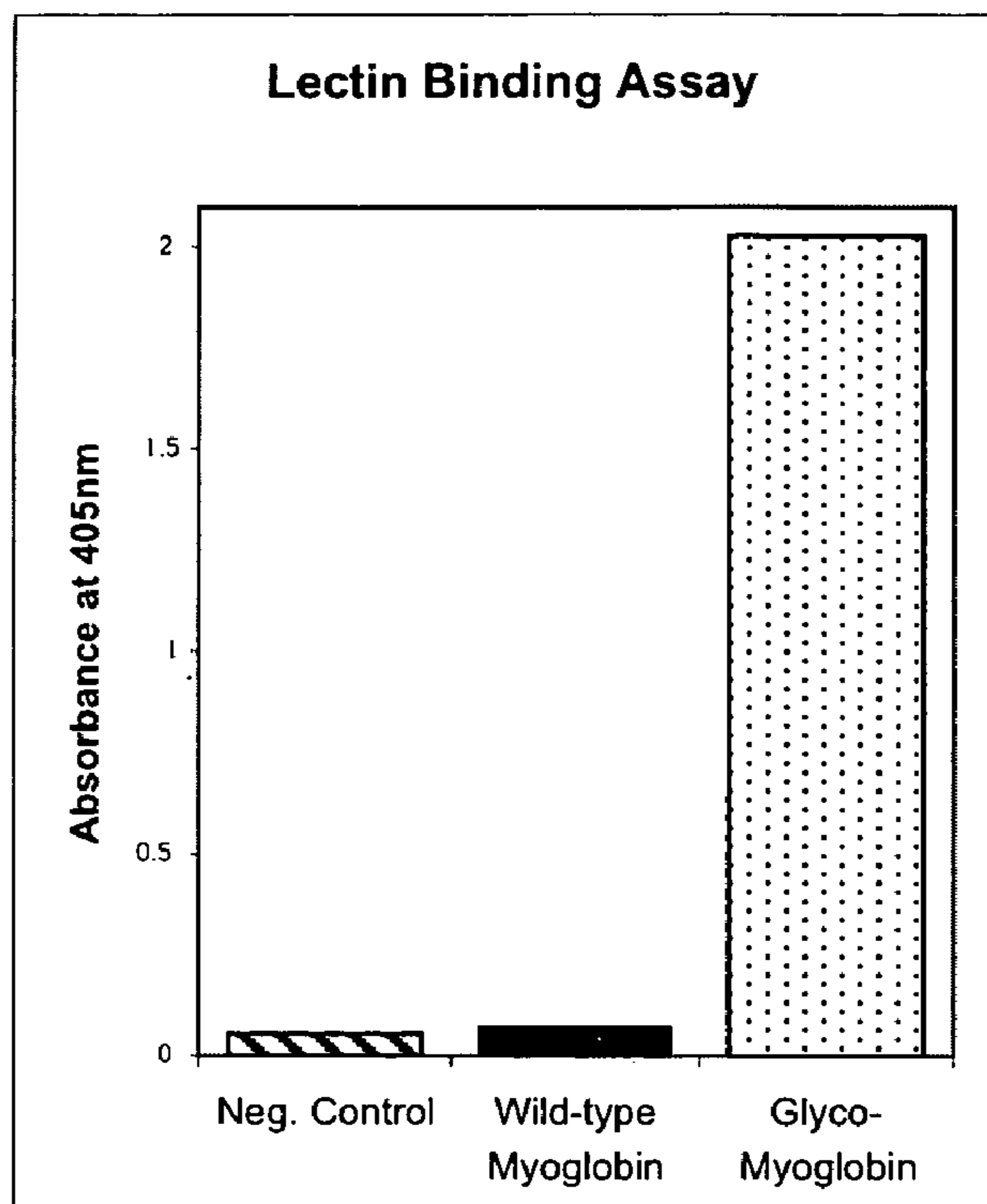

Fig. 6A

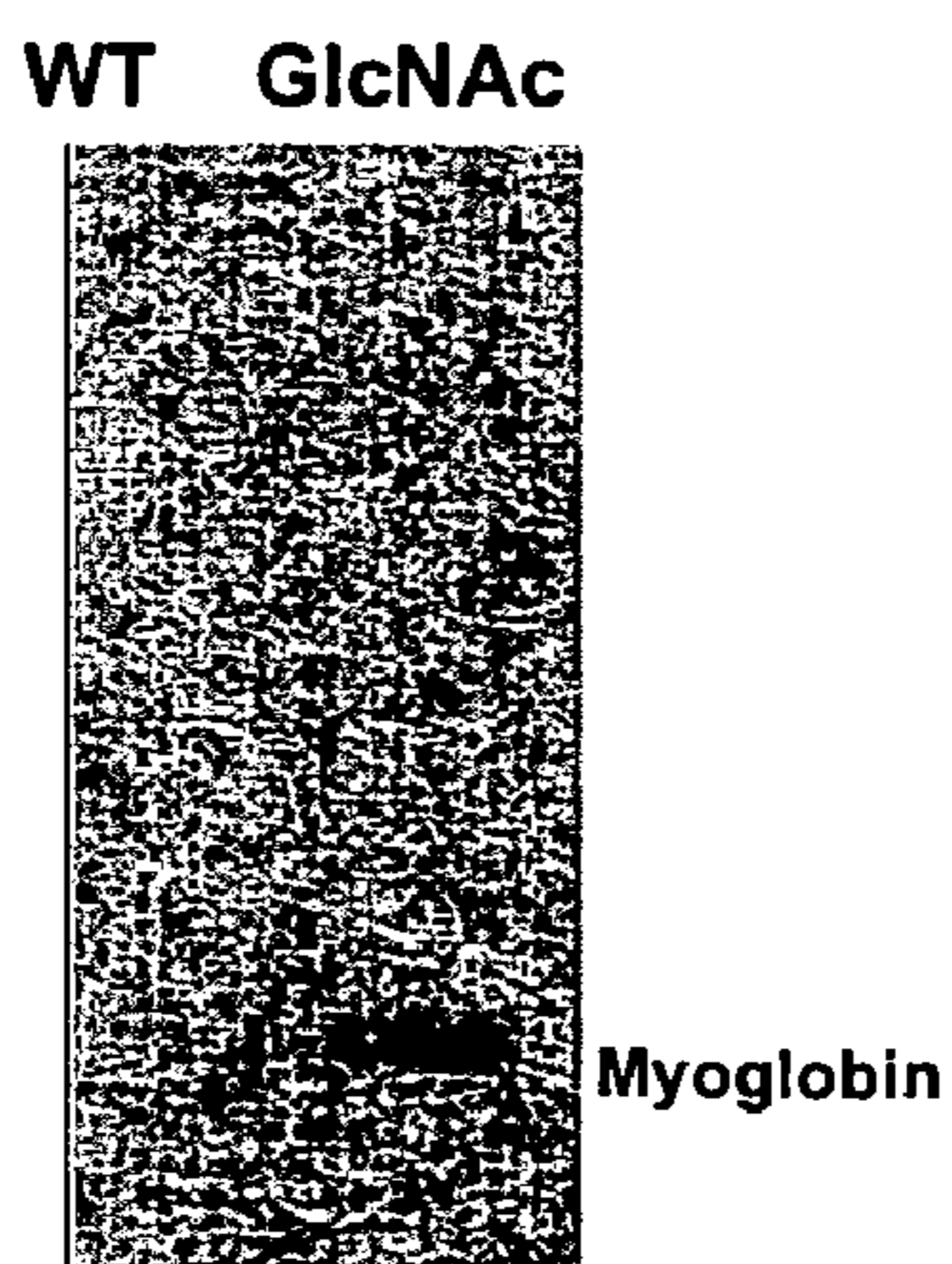

Fig. 6B

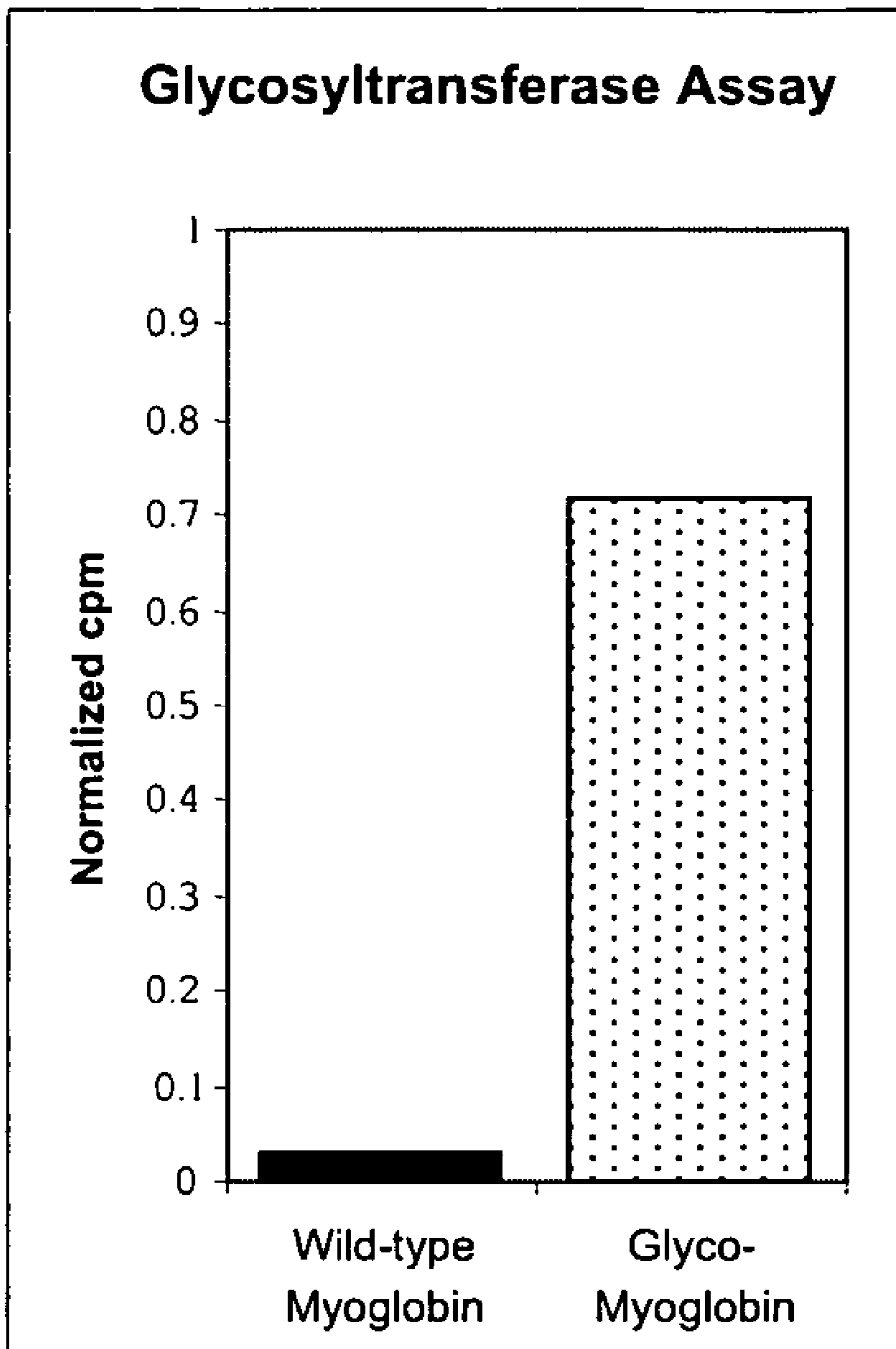

Fig. 6C

**IN VIVO SITE-SPECIFIC INCORPORATION
OF N-ACETYL-GALACTOSAMINE AMINO
ACIDS IN EUBACTERIA**

CROSS-REFERENCE TO RELATED
APPLICATIONS

[0001] This application claims priority to and benefit of U.S. Provisional Patent Application Ser. No. 60/620,898, filed Oct. 20, 2004, the specification of which is incorporated herein in its entirety for all purposes.

STATEMENT AS TO RIGHTS TO INVENTIONS
MADE UNDER FEDERALLY SPONSORED
RESEARCH AND DEVELOPMENT

[0002] This invention was made with government support under Grant No. GM44154 awarded by the National Institutes of Health. The Government may have certain rights to the invention.

FIELD OF THE INVENTION

[0003] The invention is in the field of protein biochemistry. The invention relates to compositions and methods for making and using orthogonal tRNAs, orthogonal aminoacyl-tRNA synthetases, and pairs thereof, that incorporate unnatural amino acids into proteins, where the unnatural amino acids comprise an N-acetylgalactosamine moiety and the resulting proteins are glycoproteins. The invention also relates to methods of producing proteins in cells using such pairs and related compositions. The invention is in the field of glycopeptides, glycoproteins, and related mimetics, and methods for synthesis of glycopeptides, glycoproteins, and related mimetics.

BACKGROUND OF THE INVENTION

[0004] Glycosylation is one of most prevalent posttranslational modifications (PTMs) of proteins and plays an important role in many biological processes. For example, the post-translational modification of proteins by glycosylation can affect protein folding and stability, modify the intrinsic activity of proteins, and modulate their interactions with other biomolecules. See, e.g., Varki, A. (1993) *Glycobiology* 3:97-130; Dwek (1996) *Chem. Rev.* 96:683-720; and Sears and Wong (1998) *Cell Mol. Life Sci.* 54:223-252. Natural glycoproteins are often present as a population of many different glycoforms, which makes analysis of glycan structure and the study of glycosylation effects on protein structure and function difficult. Therefore, methods for the synthesis of natural and unnatural homogeneously glycosylated proteins would be useful tools, e.g., for the systematic understanding of glycan function, and for the development of improved glycoprotein therapeutics.

[0005] Considerable effort has focused on the methods for generation of glycoproteins, including chemical and enzymatic synthetic approaches, in vitro translation, and pathway engineering. One previously known approach for making proteins having desired glycosylation patterns makes use of glycosidases to convert a heterogeneous natural glycoprotein to a simple homogenous core, onto which saccharides can then be grafted sequentially with glycosyltransferases. See, e.g., Witte, K., et al., (1997) *J. Am. Chem. Soc.* 119:2114-2118. A limitation of this approach is that the primary glycosylation sites are predetermined by the cell line in which the protein is expressed. Alternatively, a glycopeptide containing the desired glycan structure can be synthesized by solid phase

peptide synthesis. This glycopeptide can be coupled to other peptides or recombinant protein fragments to afford a larger glycoprotein by native chemical ligation (see, e.g., Shin, Y., et al., (1999) *J. Am. Chem. Soc.* 121:11684-11689) expressed protein ligation, (see, e.g., Tolbert, T. J. and Wong, C.-H. (2000) *J. Am. Chem. Soc.* 122:5421-5428), or with engineered proteases. See, e.g., Witte, K., et al., (1998) *J. Am. Chem. Soc.* 120:1979-1989. Both native chemical ligation and expressed protein ligation are most effective with small proteins, and necessitate a cysteine residue at the N-terminus of the glycopeptide. When a protease is used to ligate peptides together, the ligation site is preferably placed far away from the glycosylation site for good coupling yields. See, e.g., Witte, K., et al., (1998) *J. Am. Chem. Soc.* 120:1979-1989. A third approach is to modify proteins with saccharides directly using chemical methods. Good selectivity can be achieved with haloacetamide saccharide derivatives, which are coupled to the thiol group of cysteine, (see, e.g., Davis, N. J. and Flitsch, S. L. (1991) *Tetrahedron Lett.* 32:6793-6796; and Macmillan, D.; et al., (2002) *Org Lett* 4:1467-1470), but this method can become problematic with proteins that have more than one cysteine residue.

[0006] Accordingly, a need exists for improved methods for making glycoproteins having a desired glycosylation pattern. The invention fulfills this and other needs, as will be apparent upon review of the following disclosure.

SUMMARY OF THE INVENTION

[0007] The present invention provides methods and related compositions for the preparation of glycoproteins. In one aspect, the present invention provides orthogonal aminoacyl-tRNA synthetases that preferentially aminoacylate an orthogonal tRNA (O-tRNA) with an unnatural amino acid bearing an N-acetylgalactosamine (GalNAc) moiety, such as N-acetylgalactosamine- α -threonine or N-acetylgalactosamine- α -serine. In some embodiments, the orthogonal aminoacyl-tRNA synthetase (O-RS) is generated from a synthetase sequence originally obtained from *Methanococcus jannaschii*, for example, an amino acid sequence derived from a wild-type *Methanococcus jannaschii* tyrosyl-tRNA synthetase. Exemplary mutant *M. jannaschii* Tyr-tRNA synthetases (MjTyrRS) that can utilize GalNAc-containing unnatural amino acids include, but are not limited to, the polypeptide sequences provided in SEQ ID NO.: 1 through 4, as well as conservative variations thereof.

[0008] In some embodiments, the O-RS aminoacylates the O-tRNA with the unnatural amino acid with an efficiency that is at least 50% of the efficiency observed for a translation system comprising the unnatural amino acid, the O-tRNA and an O-RS having an amino acid sequence of SEQ ID NOs: 1, 2, 3, 4 or a conservative variant thereof.

[0009] Also provided are nucleic acids that encode the O-RS polypeptides, for example, the nucleic acids of SEQ ID NOs: 6-9 encoding exemplary orthogonal tRNA synthetases of the present invention. Furthermore, vectors, for example expression vectors, carrying these DNA sequences are provided, as well as cells comprising the vectors.

[0010] In a related aspect, the present invention provides amino acid sequences for an orthogonal aminoacyl-tRNA synthetase (O-RS) having at least 70% sequence identity with *M. jannaschii* Tyr-tRNA synthetase (SEQ ID NO:5), as determined using BLAST set to default parameters; the amino acid sequence include, but are not limited to, one or more amino acid substitutions (as compared to SEQ ID NO:

5) selected from the group consisting of Tyr32Phe, Tyr32Gln, Tyr32Ala, Tyr32Leu, Ala67Pro, Ala67Ser, Ala67Thr, His70Pro, His70Lys, Leu98Ile, Glu107Pro, Val149Ile, Gln155Ser, Asp158Val, Asp158Cys, Ile159Tyr, Leu162Arg, Gly163Cys, and Ala167Val.

[0011] Other aspects of the invention include methods for synthesis of a glycoprotein by incorporating at a selected position into a protein an unnatural amino acid that comprises a saccharide moiety (e.g., a glycosyl-containing amino acid). A glycoprotein produced by the method is also a feature of the invention. The methods include, but are not limited to, the steps of (a) providing a translation system comprising i) an unnatural amino acid with a GalNAc moiety; ii) a nucleic acid that comprises at least one selector codon and encodes the glycoprotein; iii) an orthogonal tRNA (O-tRNA) that recognizes the selector codon; and, iv) an orthogonal aminoacyl-tRNA synthetase that preferentially aminoacylates the O-tRNA with the unnatural amino acid; and (b) incorporating the glycosylated amino acid into the selected position in the protein during translation of the protein, where the selected position in the protein corresponds to the position of the selector codon in the nucleic acid, thereby producing the protein.

[0012] In some embodiments, the O—RS used in the method preferentially aminoacylates the O-tRNA with the unnatural amino acid with an efficiency that is at least 50% of the efficiency observed for a translation system comprising the glycosylated amino acid, the O-tRNA and an O—RS comprising an amino acid sequence selected from SEQ ID NOS: 1, 2, 3, 4 and conservative variants thereof.

[0013] Unnatural amino acids recognized by the synthetases of the present invention include, but are not limited to, α -GalNAc-L-threonine, α -O-GalNAc-L-serine, β -O-GlcNAc-L-serine, C-glycosides and thio-glycosyl analogs of a glycosyl-containing amino acid (e.g., compositions in which a carbon or a sulfur atom replaces the anomeric oxygen), and/or the like. The unnatural amino acids that can be used in the method also include N-acetylgalactosamine- α -threonine, 3,4,6-triacetyl-N-acetylgalactosamine- α -threonine, N-acetylgalactosamine- α -serine and 3,4,6-triacetyl-N-acetylgalactosamine- α -serine. Optionally, the incorporating step is performed in vivo.

[0014] In some embodiments, the translation system uses an O—RS derived from a wild-type *Methanococcus jannaschii* tyrosyl-tRNA synthetase.

[0015] The orthogonal tRNA and orthogonal aminoacyl-tRNA synthetase perform as an orthogonal pair (O-tRNA/O—RS pair), wherein the O-tRNA recognizes the selector codon, and incorporates the unnatural amino acid (in this case, the glycosyl-containing amino acid) into the protein in response to the selector codon. Optionally, the O-tRNA employed in the methods comprises a mutRNA_{CUA}^{Tyr}.

[0016] Exemplary orthogonal aminoacyl-tRNA synthetases for use in the incorporation of a galactosamine-containing amino acid into a peptide sequence include, but are not limited to, the polypeptides provided in SEQ ID NOS: 1-4, as well as conservative variations thereof, or is encoded by a polynucleotide comprising a polynucleotide sequence of any one of SEQ ID NOS.: 6-9 (or conservative variations thereof). Additional O—RS sequences of the present invention (e.g., that recognizes one or more glucosamine-containing amino acids) include an amino acid sequence comprising any one of

SEQ ID NOS.: 11-13, or is encoded by a polynucleotide comprising a polynucleotide sequence of any one of SEQ ID NOS.: 14-16.

[0017] The glycoprotein synthesis methods of the present invention can further involve contacting the saccharide moiety of the unnatural amino acid (or of the nascent polypeptide containing the incorporated unnatural amino acid) with a glycosyltransferase, a sugar donor moiety, and other reactants required for glycosyltransferase activity for a sufficient time and under appropriate conditions to transfer a sugar from the sugar donor moiety to the saccharide moiety. The product of this reaction can, if desired, be contacted by one or more additional glycosyltransferases, together with the appropriate sugar donor moieties, to further extend the saccharide component.

[0018] In some embodiments of the methods, providing the translation system comprises providing a cell (e.g., a prokaryotic cell, such as a *E. coli* cell) in which the O-tRNA and the O—RS is expressed and/or functions. Providing the translation system can be achieved, e.g., by growing the cell in growth media, and may optionally include co-expressing a nucleic acid sequence encoding the O—RS and/or a nucleic acid encoding the O-tRNA in the cell.

[0019] Optionally, providing the glycosylated amino acid involves converting a protected form of the unnatural amino acid (e.g., an acetylated version such as 3,4,6-triacetyl-N-acetylgalactosamine- α -threonine) to the unprotected form (e.g., an N-acetylgalactosamine- α -threonine). Deprotection of the unnatural amino acid, e.g., by nonspecific esterases in the cytosol of the cell (or other cellular-based translation system), preferably occurs prior to aminoacylating the O-tRNA and/or incorporating the unnatural amino acid into the protein.

[0020] In certain embodiments, the method further comprises contacting the product of the glycosyltransferase reaction with at least a second glycosyltransferase and a second sugar donor moiety. In one embodiment, the saccharide moiety comprises a terminal GlcNAc, the sugar donor moiety is UDP-GlcNAc and the glycosyltransferase is a β 1-4N-acetylglucosaminyltransferase. In another embodiment, the saccharide moiety comprises a terminal GlcNAc, the sugar donor moiety is UDP-Gal and the glycosyltransferase is a β 1-4-galactosyltransferase. In a further embodiment, the saccharide moiety comprises a terminal GalNAc, the sugar donor is a UDP-GlcNAc and/or a UDP-Gal, and the glycosyltransferases include a (β 1-6)N-acetylglucosaminyltransferase and/or a β 1-3-galactosyltransferase, respectively. Various sugars can optionally be added to the saccharide portion of the unnatural amino acid by using an appropriate glycosyltransferase, including, but not limited to, e.g., a galactosyltransferase, a fucosyltransferase, a glucosyltransferase, an N-acetylgalactosaminyltransferase, an N-acetylglucosaminyltransferase, a glucuronyltransferase, a sialyltransferase, a mannosyltransferase, a glucuronic acid transferase, a galacturonic acid transferase, an oligosaccharyltransferase, and the like.

[0021] In a further aspect, the present invention also provides translation systems for the preparation of glycoproteins. The translation systems of the present invention include, but are not limited to, an orthogonal tRNA (O-tRNA) that recognizes at least one selector codon, and an orthogonal aminoacyl tRNA synthetase (O—RS) that preferentially aminoacylates the O-tRNA with an unnatural amino acid that comprises a saccharide moiety (e.g., an N-acetylgalac-

tosamine moiety). One or more saccharide-containing unnatural amino acids are also provided, as either a protected or deprotected composition (e.g., a β -O-GlcNAc-L-serine, a tri-acetyl- β -O-GlcNAc-serine, an α -O-GalNAc-L-threonine, a tri-acetyl- α -O-GalNAc-threonine, an α -O-GalNAc-serine, a triacetyl- α -GalNAc-serine, the corresponding protected or unprotected thio-glycosyl analogs, and/or the like). In some embodiments, the O—RS used in the translation system is derived from a wild-type *Methanococcus jannaschii* tyrosyl-tRNA synthetase. In some embodiments, the translation system uses an O-tRNA that is an amber suppressor tRNA.

[0022] In some embodiments, the O—RS in the translation system aminoacylates the O-tRNA with the unnatural amino acid with an efficiency that is at least 50% of the efficiency observed for a translation system that uses the unnatural amino acid, the same O-tRNA and an O—RS having an amino acid sequence of SEQ ID NOS: 1, 2, 3, 4 or a conservative variant thereof.

[0023] In embodiments targeted toward the use of galactosamine-containing unnatural amino acids, the O—RS employed in the translation system can include one or more amino acid sequences selected from the group consisting of SEQ ID NOS: 1-4 and conservative variations thereof (or is encoded by a polynucleotide comprising a polynucleotide sequence of any one of SEQ ID NOS: 6-9). In other embodiments involving glucosamine-containing amino acid substrates, the O—RS comprises an amino acid sequence comprising any one of SEQ ID NOS.: 11-13, or is encoded by a polynucleotide comprising a polynucleotide sequence of any one of SEQ ID NO.: 14-16. The translation system can further include a polynucleotide that encodes a protein of interest, that polynucleotide comprising a selector codon that is recognized by the O-tRNA. In some embodiments, the translation system is a cell, such as an *E. coli* cell. The host cell can comprise the system components, including a polynucleotide encoding the O—RS (e.g., SEQ ID NOS: 6, 7, 8 or 9) and a polynucleotide encoding the O-tRNA.

[0024] The present invention also provides glycosyl-containing unnatural amino acids and O-tRNA molecules coupled to unnatural amino acids having a saccharide moiety, e.g., for use in the methods and translation systems and with the novel orthogonal tRNA synthetases of the present invention. The glycosyl-containing unnatural amino acids of the present invention include, but are not limited to, α -GalNAc-L-threonine, α -O-GalNAc-L-serine, β -O-GlcNAc-L-serine, protected versions of the glycosyl-containing amino acids, and thio-glycosyl analogs.

[0025] Artificial (e.g., man-made, and not naturally occurring) polypeptides and polynucleotides are also features of the invention. For example, an artificial polypeptide of the invention includes, e.g., (a) a polypeptide that comprises an amino acid sequence as shown in any one of SEQ ID NO.: 1-4 and 11-13; (b) a polypeptide that comprises an amino acid sequence encoded by a polynucleotide sequence as shown in any one of SEQ ID NO.: 6-9 and 14-16; (c) a polypeptide that is specifically immunoreactive with an antibody specific for a polypeptide of (a), or (b); and, (d) an amino acid sequence comprising a conservative variation of (a), (b), or (c). Antibodies and antisera that are specifically immunoreactive with an artificial polypeptide of the invention are also provided. An artificial polynucleotide of the invention includes, e.g., (a) a polynucleotide comprising a nucleotide sequence as set forth in any one of SEQ ID NO.: 6-9 and 14-16; (b) a polynucle-

otide that is complementary to or that encodes a polynucleotide sequence of (a); (c) a polynucleotide encoding a polypeptide that comprises an amino acid sequence as set forth in any one of SEQ ID NO.: 1-4 and 11-13, or a conservative variation thereof; (d) a polynucleotide that encodes an artificial polypeptide; (e) a nucleic acid that hybridizes to a polynucleotide of (a), (b), (c), or (d) under highly stringent conditions over substantially the entire length of the nucleic acid; (f) a polynucleotide that is at least 98% identical to a polynucleotide of (a), (b), (c), (d), or (e); and, (h) a polynucleotide comprising a conservative variation of (a), (b), (c), (d), (e), or (f).

Definitions

[0026] Before describing the invention in detail, it is to be understood that this invention is not limited to particular devices or biological systems, which can, of course, vary. It is also to be understood that the terminology used herein is for the purpose of describing particular embodiments only, and is not intended to be limiting. As used in this specification and the appended claims, the singular forms “a”, “an” and “the” include plural referents unless the content clearly dictates otherwise. Thus, for example, reference to “a cell” includes a combination of two or more cells; reference to “bacteria” includes cultures of bacteria; reference to “a polypeptide” includes, as a practical matter, many copies of that polypeptide; and the like.

[0027] Orthogonal: As used herein, the term “orthogonal” refers to a molecule, e.g., an orthogonal tRNA (O-tRNA) and/or an orthogonal aminoacyl-tRNA synthetase (O—RS), that functions with endogenous components of a cell with reduced efficiency as compared to a corresponding molecule that is endogenous to the cell or translation system, or that fails to function with endogenous components of the cell. In the context of tRNAs and aminoacyl-tRNA synthetases, orthogonal refers to an inability or reduced efficiency, e.g., less than 20% efficiency, less than 10% efficiency, less than 5% efficiency, or less than 1% efficiency, of an orthogonal tRNA to function with an endogenous tRNA synthetase compared to an endogenous tRNA to function with the endogenous tRNA synthetase, or of an orthogonal aminoacyl-tRNA synthetase to function with an endogenous tRNA compared to an endogenous tRNA synthetase to function with the endogenous tRNA. The orthogonal molecule lacks a functionally normal endogenous complementary molecule in the cell. For example, an orthogonal tRNA in a cell is aminoacylated by any endogenous RS of the cell with reduced or even zero efficiency, when compared to aminoacylation of an endogenous tRNA by the endogenous RS. In another example, an orthogonal RS aminoacylates any endogenous tRNA a cell of interest with reduced or even zero efficiency, as compared to aminoacylation of the endogenous tRNA by an endogenous RS. A second orthogonal molecule can be introduced into the cell that functions with the first orthogonal molecule. For example, an orthogonal tRNA/RS pair includes introduced complementary components that function together in the cell with an efficiency (e.g., 45% efficiency, 50% efficiency, 60% efficiency, 70% efficiency, 75% efficiency, 80% efficiency, 90% efficiency, 95% efficiency, or 99% or more efficiency) as compared to that of a control, e.g., a corresponding tRNA/RS endogenous pair, or an active orthogonal pair (e.g., a tyrosyl orthogonal tRNA/RS pair).

[0028] Orthogonal tyrosyl-tRNA: As used herein, an orthogonal tyrosyl-tRNA (tyrosyl-O-tRNA) is a tRNA that is

orthogonal to a translation system of interest, where the tRNA is: (1) identical or substantially similar to a naturally occurring tyrosyl-tRNA, (2) derived from a naturally occurring tyrosyl-tRNA by natural or artificial mutagenesis, (3) derived by any process that takes a sequence of a wild-type or mutant tyrosyl-tRNA sequence of (1) or (2) into account, (4) homologous to a wild-type or mutant tyrosyl-tRNA; (5) homologous to any example tRNA that is designated as a substrate for a tyrosyl-tRNA synthetase in TABLE 3, or (6) a conservative variant of any example tRNA that is designated as a substrate for a tyrosyl-tRNA synthetase in TABLE 3. The tyrosyl-tRNA can exist charged with an amino acid, or in an uncharged state. It is also to be understood that a “tyrosyl-O-tRNA” optionally is charged (aminoacylated) by a cognate synthetase with an amino acid other than tyrosine, e.g., with an unnatural amino acid comprising an N-acetylgalactosamine. Indeed, it will be appreciated that a tyrosyl-O-tRNA of the invention is advantageously used to insert essentially any amino acid, whether natural or artificial, into a growing polypeptide, during translation, in response to a selector codon.

[0029] Orthogonal tyrosyl amino acid synthetase: As used herein, an orthogonal tyrosyl amino acid synthetase (tyrosyl-O—RS) is an enzyme that preferentially aminoacylates the tyrosyl-O-tRNA with an amino acid in a translation system of interest. The amino acid that the tyrosyl-O—RS loads onto the tyrosyl-O-tRNA can be any amino acid, whether natural, unnatural or artificial, and is not limited herein. The synthetase is optionally the same as or homologous to a naturally occurring tyrosyl amino acid synthetase, or the same as or homologous to a synthetase designated as an O—RS in TABLE 3. For example, the O—RS can be a conservative variant of a tyrosyl-O—RS of TABLE 3, and/or can be at least 50%, 60%, 70%, 80%, 90%, 95%, 98%, 99% or more identical in sequence to an O—RS of TABLE 3.

[0030] Cognate: The term “cognate” refers to components that function together, e.g., an orthogonal tRNA and an orthogonal aminoacyl-tRNA synthetase. The components can also be referred to as being complementary.

[0031] Preferentially aminoacylates: As used herein in reference to orthogonal translation systems, an O—RS “preferentially aminoacylates” a cognate O-tRNA when the O—RS charges the O-tRNA with an amino acid more efficiently than it charges any endogenous tRNA in an expression system. That is, when the O-tRNA and any given endogenous tRNA are present in a translation system in approximately equal molar ratios, the O—RS will charge the O-tRNA more frequently than it will charge the endogenous tRNA. Preferably, the relative ratio of O-tRNA charged by the O—RS to endogenous tRNA charged by the O—RS is high, preferably resulting in the O—RS charging the O-tRNA exclusively, or nearly exclusively, when the O-tRNA and endogenous tRNA are present in equal molar concentrations in the translation system. The relative ratio between O-tRNA and endogenous tRNA that is charged by the O—RS, when the O-tRNA and O—RS are present at equal molar concentrations, is greater than 1:1, preferably at least about 2:1, more preferably 5:1, still more preferably 10:1, yet more preferably 20:1, still more preferably 50:1, yet more preferably 75:1, still more preferably 95:1, 98:1, 99:1, 100:1, 500:1, 1,000:1, 5,000:1 or higher.

[0032] The O—RS “preferentially aminoacylates an O-tRNA with an unnatural amino acid” when (a) the O—RS preferentially aminoacylates the O-tRNA compared to an

endogenous tRNA, and (b) where that aminoacylation is specific for the unnatural amino acid, as compared to aminoacylation of the O-tRNA by the O—RS with any natural amino acid. That is, when the unnatural and natural amino acids are present in equal molar amounts in a translation system comprising the O—RS and O-tRNA, the O—RS will load the O-tRNA with the unnatural amino acid more frequently than with the natural amino acid. Preferably, the relative ratio of O-tRNA charged with the unnatural amino acid to O-tRNA charged with the natural amino acid is high. More preferably, O—RS charges the O-tRNA exclusively, or nearly exclusively, with the unnatural amino acid. The relative ratio between charging of the O-tRNA with the unnatural amino acid and charging of the O-tRNA with the natural amino acid, when both the natural and unnatural amino acids are present in the translation system in equal molar concentrations, is greater than 1:1, preferably at least about 2:1, more preferably 5:1, still more preferably 10:1, yet more preferably 20:1, still more preferably 50:1, yet more preferably 75:1, still more preferably 95:1, 98:1, 99:1, 100:1, 500:1, 1,000:1, 5,000:1 or higher.

[0033] Selector codon: The term “selector codon” refers to codons recognized by the O-tRNA in the translation process and not recognized by an endogenous tRNA. The O-tRNA anticodon loop recognizes the selector codon on the mRNA and incorporates its amino acid, e.g., an unnatural amino acid, such as a GalNAc amino acid, at this site in the polypeptide. Selector codons can include, e.g., nonsense codons, such as, stop codons, e.g., amber, ochre, and opal codons; four or more base codons; rare codons; codons derived from natural or unnatural base pairs and/or the like.

[0034] Suppressor tRNA: A suppressor tRNA is a tRNA that alters the reading of a messenger RNA (mRNA) in a given translation system, e.g., by providing a mechanism for incorporating an amino acid into a polypeptide chain in response to a selector codon. For example, a suppressor tRNA can read through, e.g., a stop codon (e.g., an amber, ochre or opal codon), a four base codon, a rare codon, etc.

[0035] Suppression activity: As used herein, the term “suppression activity” refers, in general, to the ability of a tRNA (e.g., a suppressor tRNA) to allow translational read-through of a codon (e.g. a selector codon that is an amber codon or a 4-or-more base codon) that would otherwise result in the termination of translation or mistranslation (e.g., frame-shifting). Suppression activity of a suppressor tRNA can be expressed as a percentage of translational read-through activity observed compared to a second suppressor tRNA, or as compared to a control system, e.g., a control system lacking an O—RS.

[0036] The present invention provides various means by which suppression activity can be quantitated. Percent suppression of a particular O-tRNA and O—RS against a selector codon (e.g., an amber codon) of interest refers to the percentage of activity of a given expressed test marker (e.g., LacZ), that includes a selector codon, in a nucleic acid encoding the expressed test marker, in a translation system of interest, where the translation system of interest includes an O—RS and an O-tRNA, as compared to a positive control construct, where the positive control lacks the O-tRNA, the O—RS and the selector codon. Thus, for example, if an active positive control marker construct that lacks a selector codon has an observed activity of X in a given translation system, in units relevant to the marker assay at issue, then percent suppression of a test construct comprising the selector codon is the per-

centage of X that the test marker construct displays under essentially the same environmental conditions as the positive control marker was expressed under, except that the test marker construct is expressed in a translation system that also includes the O-tRNA and the O—RS. Typically, the translation system expressing the test marker also includes an amino acid that is recognized by the O—RS and O-tRNA. Optionally, the percent suppression measurement can be refined by comparison of the test marker to a “background” or “negative” control marker construct, which includes the same selector codon as the test marker, but in a system that does not include the O-tRNA, O—RS and/or relevant amino acid recognized by the O-tRNA and/or O—RS. This negative control is useful in normalizing percent suppression measurements to account for background signal effects from the marker in the translation system of interest.

[0037] Suppression efficiency can be determined by any of a number of assays known in the art. For example, a β -galactosidase reporter assay can be used, e.g., a derivatized lacZ plasmid (where the construct has a selector codon in the lacZ nucleic acid sequence) is introduced into cells from an appropriate organism (e.g., an organism where the orthogonal components can be used) along with plasmid comprising an O-tRNA of the invention. A cognate synthetase can also be introduced (either as a polypeptide or a polynucleotide that encodes the cognate synthetase when expressed). The cells are grown in media to a desired density, e.g., to an OD₆₀₀ of about 0.5, and β -galactosidase assays are performed, e.g., using the BetaFluor™ β -Galactosidase Assay Kit (Novagen). Percent suppression can be calculated as the percentage of activity for a sample relative to a comparable control, e.g., the value observed from the derivatized lacZ construct, where the construct has a corresponding sense codon at desired position rather than a selector codon.

[0038] Translation system: The term “translation system” refers to the components that incorporate an amino acid into a growing polypeptide chain (protein). Components of a translation system can include, e.g., ribosomes, tRNAs, synthetases, mRNA and the like. The O-tRNA and/or the O—RSs of the invention can be added to or be part of an in vitro or in vivo translation system, e.g., in a non-eukaryotic cell, e.g., a bacterium (such as *E. coli*), or in a eukaryotic cell, e.g., a yeast cell, a mammalian cell, a plant cell, an algae cell, a fungus cell, an insect cell, and/or the like. In some embodiments, a translation system can be in vitro, where a cell extract is used in place of a host cell.

[0039] Unnatural amino acid: As used herein, the term “unnatural amino acid” refers to any amino acid, modified amino acid, and/or amino acid analogue, such as a GalNAc amino acid, that is not one of the 20 common naturally occurring amino acids or seleno cysteine or pyrrolysine.

[0040] Derived from: As used herein, the term “derived from” refers to a component that is isolated from or made using a specified molecule or organism, or information from the specified molecule or organism. For example, a polypeptide that is derived from a second polypeptide comprises an amino acid sequence that is identical or substantially similar to the amino acid sequence of the second polypeptide. In the case of polypeptides, the derived species can be obtained by, for example, naturally occurring mutagenesis, artificial directed mutagenesis or artificial random mutagenesis. The mutagenesis used to derive polypeptides can be intentionally directed or intentionally random. The mutagenesis of a polypeptide to create a different polypeptide derived from the

first can be a random event (e.g., caused by polymerase infidelity) and the identification of the derived polypeptide can be serendipitous. Mutagenesis of a polypeptide typically entails manipulation of the polynucleotide that encodes the polypeptide.

[0041] Positive selection or screening marker: As used herein, the term “positive selection or screening marker” refers to a marker that when present, e.g., expressed, activated or the like, results in identification of a cell, which comprise the trait, e.g., cells with the positive selection marker, from those without the trait.

[0042] Negative selection or screening marker: As used herein, the term “negative selection or screening marker” refers to a marker that, when present, e.g., expressed, activated, or the like, allows identification of a cell that does not comprise a selected property or trait (e.g., as compared to a cell that does possess the property or trait).

[0043] Reporter: As used herein, the term “reporter” refers to a component that can be used to identify and/or select target components of a system of interest. For example, a reporter can include a protein, e.g., an enzyme, that confers antibiotic resistance or sensitivity (e.g., β -lactamase, chloramphenicol acetyltransferase (CAT), and the like), a fluorescent screening marker (e.g., green fluorescent protein (e.g., (GFP), YFP, EGFP, RFP, etc.), a luminescent marker (e.g., a firefly luciferase protein), an affinity based screening marker, or positive or negative selectable marker genes such as lacZ, β -gal/lacZ (β -galactosidase), ADH (alcohol dehydrogenase), his3, ura3, leu2, lys2, or the like.

[0044] Eukaryote: As used herein, the term “eukaryote” refers to organisms belonging to the Kingdom Eucarya. Eukaryotes are generally distinguishable from prokaryotes by their typically multicellular organization (but not exclusively multicellular, for example, yeast), the presence of a membrane-bound nucleus and other membrane-bound organelles, linear genetic material (i.e., linear chromosomes), the absence of operons, the presence of introns, message capping and poly-A mRNA, and other biochemical characteristics, such as a distinguishing ribosomal structure. Eukaryotic organisms include, for example, animals (e.g., mammals, insects, reptiles, birds, etc.), ciliates, plants (e.g., monocots, dicots, algae, etc.), fungi, yeasts, flagellates, microsporidia, protists, etc.

[0045] Prokaryote: As used herein, the term “prokaryote” refers to organisms belonging to the Kingdom Monera (also termed Procarya). Prokaryotic organisms are generally distinguishable from eukaryotes by their unicellular organization, asexual reproduction by budding or fission, the lack of a membrane-bound nucleus or other membrane-bound organelles, a circular chromosome, the presence of operons, the absence of introns, message capping and poly-A mRNA, and other biochemical characteristics, such as a distinguishing ribosomal structure. The Prokarya include subkingdoms Eubacteria and Archaea (sometimes termed “Archaeobacteria”). Cyanobacteria (the blue green algae) and mycoplasma are sometimes given separate classifications under the Kingdom Monera.

[0046] Bacteria: As used herein, the terms “bacteria” and “eubacteria” refer to prokaryotic organisms that are distinguishable from Archaea. Similarly, Archaea refers to prokaryotes that are distinguishable from eubacteria. Eubacteria and Archaea can be distinguished by a number morphological and biochemical criteria. For example, differences in ribosomal RNA sequences, RNA polymerase structure, the

presence or absence of introns, antibiotic sensitivity, the presence or absence of cell wall peptidoglycans and other cell wall components, the branched versus unbranched structures of membrane lipids, and the presence/absence of histones and histone-like proteins are used to assign an organism to Eubacteria or Archaea.

[0047] Examples of Eubacteria include *Escherichia coli*, *Thermus thermophilus* and *Bacillus stearothermophilus*. Example of Archaea include *Methanococcus jannaschii* (Mj), *Methanosarcina mazei* (Mm), *Methanobacterium thermoautotrophicum* (Mt), *Methanococcus maripaludis*, *Methanopyrus kandleri*, *Halobacterium* such as *Haloferax volcanii* and *Halobacterium species* NRC-1, *Archaeoglobus fulgidus* (Af), *Pyrococcus furiosus* (Pf), *Pyrococcus horikoshii* (Ph), *Pyrobaculum aerophilum*, *Pyrococcus abyssi*, *Sulfolobus solfataricus* (Ss), *Sulfolobus tokodaii*, *Aeuiropyrum pernix* (Ap), *Thermoplasma acidophilum* and *Thermoplasma volcanium*.

[0048] Conservative variant: As used herein, the term “conservative variant,” in the context of a translation component, refers to a translation component, e.g., a conservative variant O-tRNA or a conservative variant O—RS, that functionally performs similar to a base component that the conservative variant is similar to, e.g., an O-tRNA or O—RS, having variations in the sequence as compared to a reference O-tRNA or O—RS. For example, an O—RS, or a conservative variant of that O—RS, will aminoacylate a cognate O-tRNA with an unnatural amino acid, e.g., an amino acid comprising an N-acetylgalactosamine moiety. In this example, the O—RS and the conservative variant O—RS do not have the same amino acid sequences. The conservative variant can have, e.g., one variation, two variations, three variations, four variations, or five or more variations in sequence, as long as the conservative variant is still complementary to the corresponding O-tRNA or O—RS.

[0049] In some embodiments, a conservative variant O—RS comprises one or more conservative amino acid substitutions compared to the O—RS from which it was derived. In some embodiments, a conservative variant O—RS comprises one or more conservative amino acid substitutions compared to the O—RS from which it was derived, and furthermore, retains O—RS biological activity; for example, a conservative variant O—RS that retains at least 10% of the biological activity of the parent O—RS molecule from which it was derived, or alternatively, at least 20%, at least 30%, or at least 40%. In some preferred embodiments, the conservative variant O—RS retains at least 50% of the biological activity of the parent O—RS molecule from which it was derived. The conservative amino acid substitutions of a conservative variant O—RS can occur in any domain of the O—RS, including the amino acid binding pocket.

[0050] Selection or screening agent: As used herein, the term “selection or screening agent” refers to an agent that, when present, allows for selection/screening of certain components from a population. For example, a selection or screening agent can be, but is not limited to, e.g., a nutrient, an antibiotic, a wavelength of light, an antibody, an expressed polynucleotide, or the like. The selection agent can be varied, e.g., by concentration, intensity, etc.

[0051] In response to: As used herein, the term “in response to” refers to the process in which a O-tRNA of the invention recognizes a selector codon and mediates the incorporation the GalNAc amino acid, which is coupled to the tRNA, into the growing polypeptide chain.

[0052] Encode: As used herein, the term “encode” refers to any process whereby the information in a polymeric macromolecule or sequence string is used to direct the production of a second molecule or sequence string that is different from the first molecule or sequence string. As used herein, the term is used broadly, and can have a variety of applications. In one aspect, the term “encode” describes the process of semi-conservative DNA replication, where one strand of a double-stranded DNA molecule is used as a template to encode a newly synthesized complementary sister strand by a DNA-dependent DNA polymerase.

[0053] In another aspect, the term “encode” refers to any process whereby the information in one molecule is used to direct the production of a second molecule that has a different chemical nature from the first molecule. For example, a DNA molecule can encode an RNA molecule (e.g., by the process of transcription incorporating a DNA-dependent RNA polymerase enzyme). Also, an RNA molecule can encode a polypeptide, as in the process of translation. When used to describe the process of translation, the term “encode” also extends to the triplet codon that encodes an amino acid. In some aspects, an RNA molecule can encode a DNA molecule, e.g., by the process of reverse transcription incorporating an RNA-dependent DNA polymerase. In another aspect, a DNA molecule can encode a polypeptide, where it is understood that “encode” as used in that case incorporates both the processes of transcription and translation.

[0054] Saccharide moiety: As used herein, the terms “saccharide moiety” and “glycosyl moiety” refers to natural and unnatural sugar moieties (i.e., a non-naturally occurring sugar moiety, e.g., a sugar moiety that is modified, e.g., at one or more hydroxyl or amino positions, e.g., dehydroxylated, deaminated, acetylated, esterified, etc., e.g., 2-deoxyGal is an example of an unnatural sugar moiety). The term “carbohydrate” has the general formula $(CH_2O)_n$, and includes, but is not limited to, e.g., monosaccharides, disaccharides, oligosaccharides and polysaccharides. Oligosaccharides are chains composed of saccharide units, which are alternatively known as sugars. Saccharide units can be arranged in any order and the linkage between two saccharide units can occur in any of approximately ten different ways.

[0055] The following glycosyl-related abbreviations are used herein:

[0056] Ara=arabinosyl;

[0057] Fru=fructosyl;

[0058] Fuc=fucosyl;

[0059] Gal=galactosyl;

[0060] GalNAc=N-acetylgalactosaminyl;

[0061] Glc=glucosyl;

[0062] GlcNAc=N-acetylglucosaminyl;

[0063] Man=mannosyl; and

[0064] NeuAc=sialyl (typically N-acetylneuraminyl).

[0065] Unless otherwise defined herein or below in the remainder of the specification, all technical and scientific terms used herein have the same meaning as commonly understood by those of ordinary skill in the art to which the invention belongs.

BRIEF DESCRIPTION OF THE DRAWINGS

[0066] FIG. 1 schematically illustrates the “charging” of Tyr-tRNA_{CUA} with the unnatural amino acid GalNAc- α -threonine 1 after removal of the acetyl groups of the per-acetylated precursor 2 (e.g., by nonspecific cytosolic esterases). The GalNAc- α -threonine can then be site-specifically incorpo-

rated in vivo into recombinant glycoproteins during biosynthesis (e.g., in *E. coli*), by readthrough of nonsense amber codon UAG.

[0067] FIG. 2 schematically depicts a synthetic approach to the preparation of peracetylated GalNAc- α -threonine.

[0068] FIGS. 3A-3C illustrate the expression of the myoglobin 4TAG mutant gene with the evolved AH1 (FIG. 3A) and C10F (FIG. 3B) MjTyrRS, demonstrating the protein levels generated in the presence (+) versus absence (-) of the N-acetylgalactosamine- α -O-threonine substrate. M=protein markers (kDa). FIG. 3C depicts high resolution ESI-TOF mass spectrum of myoglobin expressed with C10F and glycosyl amino acid 2 shows peaks for GalNAc- α -Thr incorporation (expected average MH+18448.8) and tyrosine incorporation (expected average MH+18431.2). Sample mixtures were separated by reverse-phase chromatography.

[0069] FIGS. 4A and 4B, illustrate binding of a GalNAc-specific lectins *Vicia Villosa* lectin (VVL) and *Dolichos Biflorus* lectin (DBL) to glycomyoglobin samples. A 10-fold and 5 fold increase in ELLA signal, with VVL and DBL, respectively, was observed for myoglobin samples expressed with GalNAc- α -Thr (+) versus those grown in the absence (-) of the glycosyl amino acid. Control samples ("blank") composed of pNPP substrate without any AP-St, depict background hydrolysis.

[0070] FIG. 5A illustrates expression of the Gly4 \rightarrow A mutant myoglobin (~18.5 kDa). Proteins were purified by Ni²⁺-affinity chromatography and resolved by SDS-PAGE. The gel was silver-stained. FIG. 5B illustrates MALDI-TOF analysis of the molecular weight of the Gly4 \rightarrow A mutant myoglobin.

[0071] FIGS. 6A-6C illustrate characterization of the purified mutant myoglobin containing a glycosylated amino acid. FIG. 6A illustrates binding of a GlcNAc-specific lectin, *Banaderiraea simplicifolia* II (BSII), to wild-type myoglobin and glycomyoglobin. FIG. 6B illustrates on-blot galactosyltransferase labeling glycomyoglobin with UDP-[H³]galactose. FIG. 6C illustrates quantitative analysis of the galactosyltransferase reaction, which was carried out in solution, and the radiolabeled galactose was normalized such that 1.0 corresponds to 100% transfer.

DETAILED DESCRIPTION

[0072] Posttranslational modifications of proteins regulate many biological processes, including metabolism, signal transduction, and gene expression. The synthetic challenges associated with generating homogeneous populations of selectively modified proteins, however, have hindered detailed studies of the effects of these modifications on protein structure and function. For example, glycosylation is one of the most common post-translational modifications of proteins in eukaryotes and affects a wide range of protein functions from folding and secretion to biomolecular recognition and serum half life. See, e.g., R. A. Dwek, (1996) *Chem. Rev.* 96:683.

[0073] While there have been significant advances in our understanding of the effects of glycosylation, the specific roles of oligosaccharide chains and the relationships between their structures and functions are just beginning to be understood. See, e.g., C. R. Bertozzi, & L. L. Kiessling, (2001) *Science* 291:2357. The primary challenge is that glycoproteins are typically produced as a mixture of glycoforms, making it difficult to isolate unique glycoforms from natural sources. A variety of methods have been developed to syn-

thesize structurally defined glycoforms, but all impose severe restrictions on the size, quantity, and/or quality of the glycoprotein produced. See, e.g., P. Sears, & C. H. Wong, (2001) *Science* 291:2344; M. Wacker et al., (2002) *Science* 298:1790; B. G. Davis, (2002) *Chem. Rev.* 102:579; and, H. C. Hang, & C. R. Bertozzi, (2001) *Acc. Chem. Res.* 34:727.

[0074] The invention solves this and other problems, and provides glycoproteins and glycoprotein mimetics, and highly efficient novel methods for synthesis of glycoproteins having desired glycosylation patterns. The glycoproteins and glycoprotein mimetics of the invention have utility in producing homogeneous glycoforms of therapeutic glycoproteins and/or facilitating the studies on the structures and functions of glycosylated proteins.

[0075] The solution provided by the present invention uses programmed, site-specific biosynthetic incorporation of unnatural amino acids containing N-acetylgalactosamine moieties into proteins using orthogonal translation components. This strategy results in an expansion of the genetic code and adds N-acetylgalactosamine amino acids to the biological translation repertoire. This approach is made feasible by the use of "orthogonal" tRNAs and corresponding novel "orthogonal" aminoacyl-tRNA synthetases to incorporate the unnatural amino acids directly to a growing protein chain using the in vivo protein biosynthetic machinery of a host cell (e.g., a eubacterial *Escherichia coli* host cell).

[0076] We report herein the evolution of novel orthogonal translation systems for the highly efficient genetic incorporation of N-acetylgalactosamine (GalNAc) amino acids into proteins produced in eubacteria host cells (e.g., *E. coli*) in response to the amber nonsense codon, TAG. The novel compositions and methods described herein employ orthogonal tRNA (O-tRNA)/aminoacyl-tRNA synthetase (O-RS) systems, where the orthogonal system uses components derived from *Methanococcus janaschii*, and where these components are used in a eubacterial host system for producing a protein of interest. The incorporation of N-acetylgalactosamine amino acids into the protein can be programmed to occur at any desired position by engineering the polynucleotide encoding the protein of interest to contain a selector codon that signals the incorporation of the N-acetylgalactosamine amino acid.

Orthogonal tRNA/Aminoacyl-tRNA Synthetase Technology

[0077] An understanding of the novel compositions and methods of the present invention is facilitated by an understanding of the activities associated with orthogonal tRNA and orthogonal aminoacyl-tRNA synthetase pairs. Discussions of orthogonal tRNA and aminoacyl-tRNA synthetase technologies can be found, for example, in various sources, e.g., Wang et al., (2001), *Science* 292:498-500; Chin et al., (2002) *Journal of the American Chemical Society* 124:9026-9027; Chin and Schultz, (2002), *ChemBioChem* 11:1 135-1137; Chin, et al., (2002), *PNAS United States of America* 99:11020-11024; and Wang and Schultz, (2002), *Chem. Comm.*, 1-10. See also, International Publications WO 2002/086075, entitled "METHODS AND COMPOSITIONS FOR THE PRODUCTION OF ORTHOGONAL tRNA AMINOACYL-tRNA SYNTHETASE PAIRS;" WO 2002/085923, entitled "IN VIVO INCORPORATION OF UNNATURAL AMINO ACIDS;" WO 2004/094593, entitled "EXPANDING THE EUKARYOTIC GENETIC CODE;" WO 2005/019415, filed Jul. 7, 2004; WO 2005/007870, filed Jul. 7, 2004; and WO 2005/007624, filed Jul. 7, 2004. Each of these

references and published patent applications is incorporated herein by reference in its entirety.

[0078] In order to add additional reactive unnatural amino acids, such as GalNAc amino acids, to the genetic code, new orthogonal pairs comprising an aminoacyl-tRNA synthetase and a suitable tRNA are needed that can function efficiently in the host translational machinery, but that are “orthogonal” to the translation system at issue, meaning that it functions independently of the synthetases and tRNAs endogenous to the translation system. Desired characteristics of the orthologous pair include tRNA that decode or recognize only a specific codon, e.g., a selector codon, that is not decoded by any endogenous tRNA, and aminoacyl-tRNA synthetases that preferentially aminoacylate (or “charge”) its cognate tRNA with only one specific unnatural amino acid. The O-tRNA is also not typically aminoacylated by endogenous synthetases. For example, in *E. coli*, an orthogonal pair will include an aminoacyl-tRNA synthetase that does not cross-react with any of the endogenous tRNA, e.g., which there are 40 in *E. coli*, and an orthogonal tRNA that is not aminoacylated by any of the endogenous synthetases, e.g., of which there are 21 in *E. coli*.

[0079] The invention described herein provides orthogonal pairs for the genetic encoding and incorporation of GalNAc amino acids into proteins in a eubacteria, e.g., *E. coli*, where the orthogonal components do not cross-react with endogenous *E. coli* components of the translational machinery of the host cell, but recognize the desired unnatural amino acid and incorporate it into proteins in response to the amber nonsense codon, TAG. The orthogonal components provided by the invention include orthogonal aminoacyl-tRNA synthetases derived from *Methanococcus jannaschii* tyrosyl tRNA-synthetase, and the mutant tyrosyl tRNA_{CUA} amber suppressor. In this system, the mutant aminoacyl-tRNA synthetases aminoacylate the suppressor tRNA with, e.g., GalNAc- α -threonine, and not with any of the common twenty amino acids.

[0080] This invention provides compositions of and methods for identifying and producing additional orthogonal tRNA-aminoacyl-tRNA synthetase pairs, e.g., O-tRNA/O—RS pairs that can be used to incorporate a GalNAc amino acid into a protein. An O-tRNA of the invention is capable of mediating incorporation of GalNAc amino acids into a protein that is encoded by a polynucleotide, which comprises a selector codon that is recognized by the O-tRNA, e.g., in vivo. The anticodon loop of the O-tRNA recognizes the selector codon on an mRNA and incorporates its amino acid, e.g., a GalNAc amino acid at this site in the polypeptide. An orthogonal aminoacyl-tRNA synthetase of the invention preferentially aminoacylates (or charges) its O-tRNA with only one specific GalNAc amino acid.

[0081] For example, as demonstrated herein, the amino acid GalNAc- α -threonine was incorporated selectively and efficiently into a protein in a eubacterial cell (*Escherichia coli*; *E. coli*) in response to a selector codon, e.g., the TAG codon. The ability to incorporate a GalNAc amino acid site-specifically into proteins can facilitate the study of proteins, as well as enable the engineering of proteins with novel properties.

Orthogonal tRNA/Orthogonal Aminoacyl-tRNA Synthetases and Translation Systems

[0082] Translation systems that are suitable for making proteins that include one or more unnatural amino acids are described in, for example, International Publication Numbers

WO 2002/086075, entitled “METHODS AND COMPOSITION FOR THE PRODUCTION OF ORTHOGONAL tRNA-AMINOACYL-tRNA SYNTHETASE PAIRS;” WO 2002/085923, entitled “IN VIVO INCORPORATION OF UNNATURAL AMINO ACIDS;” and WO 2004/094593, entitled “EXPANDING THE EUKARYOTIC GENETIC CODE;” WO 2005/019415, filed Jul. 7, 2004; WO 2005/007870, filed Jul. 7, 2004 and WO 2005/007624, filed Jul. 7, 2004. Each of these applications is incorporated herein by reference in its entirety. Such translation systems generally comprise cells (which can be non-eukaryotic cells such as *E. coli*, or eukaryotic cells such as yeast) that include an orthogonal tRNA (O-tRNA), an orthogonal aminoacyl tRNA synthetase (O—RS), and an unnatural amino acid (e.g., in the present invention, a GalNAc amino acid), where the O—RS aminoacylates the O-tRNA with the GalNAc amino acid. An orthogonal pair of the invention includes an O-tRNA, e.g., a suppressor tRNA, a frameshift tRNA, or the like, and an O—RS. Individual components are also provided in the invention.

[0083] The present invention provides novel orthogonal tRNA synthetases (O—RSs) for use in the generation of glycoproteins, e.g., using the methods, translation systems and/or kits of the present invention. In addition to the O—RS, the methods translation systems and kits generally also include an orthogonal tRNA (e.g., a suppressor tRNA, a frameshift tRNA, or the like), and a glycosyl-containing unnatural amino acid, with which the O—RS aminoacylates the O-tRNA. The development of multiple orthogonal tRNA/synthetase pairs (an O-tRNA and an O—RS) can allow the simultaneous incorporation of multiple unnatural amino acids using different codons. Table 3 provides exemplary O—RS and O-tRNA sequences of the present invention.

[0084] In general, when an orthogonal pair recognizes a selector codon and loads an amino acid in response to the selector codon, the orthogonal pair is said to “suppress” the selector codon. That is, a selector codon that is not recognized by the translation system’s (e.g., the cell’s) endogenous machinery is not ordinarily translated, which can result in blocking production of a polypeptide that would otherwise be translated from the nucleic acid. An O-tRNA of the invention recognizes a selector codon and includes at least about, e.g., a 45%, a 50%, a 60%, a 75%, a 80%, or a 90% or more suppression efficiency in the presence of a cognate synthetase in response to a selector codon as compared to the suppression efficiency of an O-tRNA comprising or encoded by a polynucleotide sequence as set forth in the sequence listing herein. The O—RS aminoacylates the O-tRNA with an unnatural amino acid of interest, such as a GalNAc amino acid. The cell uses the O-tRNA/O—RS pair to incorporate the unnatural amino acid into a growing polypeptide chain, e.g., via a nucleic acid that comprises a polynucleotide that encodes a polypeptide of interest, where the polynucleotide comprises a selector codon that is recognized by the O-tRNA. In certain desirable aspects, the cell can include an additional O-tRNA/O—RS pair, where the additional O-tRNA is loaded by the additional O—RS with a different unnatural amino acid. For example, one of the O-tRNAs can recognize a four base codon and the other can recognize a stop codon. Alternately, multiple different stop codons or multiple different four base codons can specifically recognize different selector codons.

[0085] In certain embodiments of the invention, a cell such as an *E. coli* cell that includes an orthogonal tRNA (O-tRNA),

an orthogonal aminoacyl-tRNA synthetase (O—RS), a GalNAc amino acid and a nucleic acid that comprises a polynucleotide that encodes a polypeptide of interest, where the polynucleotide comprises the selector codon that is recognized by the O-tRNA. The translation system can also be a cell-free system, e.g., any of a variety of commercially available “in vitro” transcription/translation systems in combination with an O-tRNA/ORS pair and an unnatural amino acid as described herein.

[0086] In one embodiment, the suppression efficiency of the O—RS and the O-tRNA together is about, e.g., 5 fold, 10 fold, 15 fold, 20 fold, or 25 fold or more greater than the suppression efficiency of the O-tRNA lacking the O—RS. In one aspect, the suppression efficiency of the O—RS and the O-tRNA together is at least about, e.g., 35%, 40%, 45%, 50%, 60%, 75%, 80%, or 90% or more of the suppression efficiency of an orthogonal synthetase pair as set forth in the sequence listings herein.

[0087] As noted, the invention optionally includes multiple O-tRNA/O—RS pairs in a cell or other translation system, which allows incorporation of more than one unnatural amino acid, e.g., a GalNAc amino acid and another unnatural amino acid. For example, the cell can further include an additional different O-tRNA/O—RS pair and a second unnatural amino acid, where this additional O-tRNA recognizes a second selector codon and this additional O—RS preferentially aminoacylates the O-tRNA with the second unnatural amino acid. For example, a cell that includes an O-tRNA/O—RS pair (where the O-tRNA recognizes, e.g., an amber selector codon), can further comprise a second orthogonal pair, e.g., leucyl, lysyl, glutamyl, etc., (where the second O-tRNA recognizes a different selector codon, e.g., an opal codon, a four-base codon, or the like). Desirably, the different orthogonal pairs are derived from different sources, which can facilitate recognition of different selector codons.

[0088] The O-tRNA and/or the O—RS can be naturally occurring or can be, e.g., derived by mutation of a naturally occurring tRNA and/or RS, e.g., by generating libraries of tRNAs and/or libraries of RSs, from any of a variety of organisms and/or by using any of a variety of available mutation strategies. For example, one strategy for producing an orthogonal tRNA/aminoacyl-tRNA synthetase pair involves importing a heterologous (to the host cell) tRNA/synthetase pair from, e.g., a source other than the host cell, or multiple sources, into the host cell. The properties of the heterologous synthetase candidate include, e.g., that it does not charge any host cell tRNA, and the properties of the heterologous tRNA candidate include, e.g., that it is not aminoacylated by any host cell synthetase. In addition, the heterologous tRNA is orthogonal to all host cell synthetases.

[0089] A second strategy for generating an orthogonal pair involves generating mutant libraries from which to screen and/or select an O-tRNA or O—RS. These strategies can also be combined.

[0090] Orthogonal tRNA (O-tRNA)

[0091] An orthogonal tRNA (O-tRNA) of the invention desirably mediates incorporation of an unnatural amino acid, such as an unnatural amino acid that includes a saccharide moiety, e.g., a GalNAc amino acid, into a protein that is encoded by a polynucleotide that comprises a selector codon that is recognized by the O-tRNA, e.g., in vivo or in vitro. The O-tRNA that contains an anticodon sequence corresponding to a desired selector codon can only be aminoacylated by the corresponding O—RS, and not by endogenous synthetases.

In certain embodiments, an O-tRNA of the invention includes at least about, e.g., a 45%, a 50%, a 60%, a 75%, a 80%, or a 90% or more suppression efficiency in the presence of a cognate synthetase in response to a selector codon as compared to an O-tRNA comprising or encoded by a polynucleotide sequence as set forth in the O-tRNA sequences in the sequence listing herein.

[0092] An example of an orthogonal tRNA that can be used in the methods, translation systems, and kits of the invention is SEQ ID NO.:17. In the tRNA molecule, thymine (T) is replaced with uracil (U); however, additional modifications to the bases can also be present. The invention also includes conservative variations of O-tRNA. For example, conservative variations of O-tRNA include those molecules that function like the O-tRNA of SEQ ID NO.: 17 and maintain the tRNA L-shaped structure, but do not have the same sequence (and are other than wild type tRNA molecules). See also the section herein entitled “Nucleic acids and Polypeptides Sequence and Variants.” Methods for producing a recombinant orthogonal tRNA (O-tRNA) are provided in International patent application WO 2002/086075, *supra*.

[0093] Additional methods for producing a recombinant orthogonal tRNA can be found, e.g., in International patent applications WO 2002/086075, as well as Forster et al. (2003) “Programming peptidomimetic synthetases by translating genetic codes designed de novo” *Proc. Natl. Acad. Sci. USA* 100(11):6353-6357; and, Feng et al., (2003) “Expanding tRNA recognition of a tRNA synthetase by a single amino acid change” *Proc. Natl. Acad. Sci. USA* 100(10): 5676-5681.

[0094] Suppression efficiency of a particular orthogonal translation system (or any component in that system such as an O-tRNA or an O—RS) can be determined by any of a number of assays known in the art. For example, a β -galactosidase reporter assay can be used, e.g., a derivatized lacZ plasmid (where the construct has a selector codon in the lacZ nucleic acid sequence) is introduced into cells from an appropriate organism (e.g., an organism where the orthogonal components can be used) along with plasmid comprising an O-tRNA of the invention. A cognate synthetase can also be introduced (either as a polypeptide or a polynucleotide that encodes the cognate synthetase when expressed). The cells are grown in media to a desired density, e.g., to an OD₆₀₀ of about 0.5, and β -galactosidase assays are performed, e.g., using the BetaFluor™ β -Galactosidase Assay Kit (Novagen). Percent suppression can be calculated as the percentage of activity for a sample relative to a comparable control, e.g., the value observed from the derivatized lacZ construct, where the construct has a corresponding sense codon at desired position rather than a selector codon.

[0095] Examples of O-tRNAs of the invention are set forth in the sequence listing herein. See also, the tables, examples and figures herein for sequences of exemplary O-tRNA and O—RS molecules. See also, the section entitled “Nucleic Acid and Polypeptide Sequence and Variants” herein. In an RNA molecule, such as an O—RS mRNA, or O-tRNA molecule, Thymine (T) is replaced with Uracil (U) relative to a given sequence (or vice versa for a coding DNA), or complement thereof. Additional modifications to the bases can also be present.

[0096] The invention also includes conservative variations of O-tRNAs corresponding to particular O-tRNAs herein. For example, conservative variations of O-tRNA include those molecules that function like the particular O-tRNAs from which they were derived, e.g., as in the sequence listing herein

and that maintain the tRNA L-shaped structure by virtue of appropriate self-complementarity, but that do not have a sequence identical to those, e.g., in the sequence listing, figures or examples herein (and, desirably, are other than wild type tRNA molecules).

[0097] The composition comprising an O-tRNA can further include an orthogonal aminoacyl-tRNA synthetase (O-RS), where the O-RS preferentially aminoacylates the O-tRNA with an unnatural amino acid such as a GalNAc amino acid. In certain embodiments, a composition including an O-tRNA can further include a translation system (e.g., in vitro or in vivo). A nucleic acid that comprises a polynucleotide that encodes a polypeptide of interest, where the polynucleotide comprises a selector codon that is recognized by the O-tRNA, or a combination of one or more of these can also be present in the cell.

[0098] Methods of producing an orthogonal tRNA (O-tRNA) are also a feature of the invention. An O-tRNA produced by the method is also a feature of the invention. In certain embodiments of the invention, the O-tRNAs can be produced by generating a library of mutants. The library of mutant tRNAs can be generated using various mutagenesis techniques known in the art. For example, the mutant tRNAs can be generated by site-specific mutations, random point mutations, homologous recombination, DNA shuffling or other recursive mutagenesis methods, chimeric construction or any combination thereof.

[0099] Additional mutations can be introduced at a specific position(s), e.g., at a nonconservative position(s), or at a conservative position, at a randomized position(s), or a combination of both in a desired loop or region of a tRNA, e.g., an anticodon loop, the acceptor stem, D arm or loop, variable loop, TPC arm or loop, other regions of the tRNA molecule, or a combination thereof. Typically, mutations in a tRNA include mutating the anticodon loop of each member of the library of mutant tRNAs to allow recognition of a selector codon. The method can further include adding an additional sequence (CCA) to a terminus of the O-tRNA. Typically, an O-tRNA possesses an improvement of orthogonality for a desired organism compared to the starting material, e.g., the plurality of tRNA sequences, while preserving its affinity towards a desired RS.

[0100] The methods optionally include analyzing the similarity (and/or inferred homology) of sequences of tRNAs and/or aminoacyl-tRNA synthetases to determine potential candidates for an O-tRNA, O-RS and/or pairs thereof, that appear to be orthogonal for a specific organism. Computer programs known in the art and described herein can be used for the analysis, e.g., BLAST and pileup programs can be used. In one example, to choose potential orthogonal translational components for use in *E. coli*, a synthetase and/or a tRNA is chosen that does not display close sequence similarity to eubacterial organisms;

[0101] Typically, an O-tRNA is obtained by subjecting to, e.g., negative selection, a population of cells of a first species, where the cells comprise a member of the plurality of potential O-tRNAs. The negative selection eliminates cells that comprise a member of the library of potential O-tRNAs that is aminoacylated by an aminoacyl-tRNA synthetase (RS) that is endogenous to the cell. This provides a pool of tRNAs that are orthogonal to the cell of the first species.

[0102] In certain embodiments, in the negative selection, a selector codon(s) is introduced into a polynucleotide that encodes a negative selection marker, e.g., an enzyme that

confers antibiotic resistance, e.g., β -lactamase, an enzyme that confers a detectable product, e.g., β -galactosidase, chloramphenicol acetyltransferase (CAT), e.g., a toxic product, such as barnase, at a nonessential position (e.g., still producing a functional barnase), etc. Screening/selection is optionally done by growing the population of cells in the presence of a selective agent (e.g., an antibiotic, such as ampicillin). In one embodiment, the concentration of the selection agent is varied.

[0103] For example, to measure the activity of suppressor tRNAs, a selection system is used that is based on the in vivo suppression of selector codon, e.g., nonsense or frameshift mutations introduced into a polynucleotide that encodes a negative selection marker, e.g., a gene for β -lactamase (*bla*). For example, polynucleotide variants, e.g., *bla* variants, with a selector codon at a certain position (e.g., A184), are constructed. Cells, e.g., bacteria, are transformed with these polynucleotides. In the case of an orthogonal tRNA, which cannot be efficiently charged by endogenous *E. coli* synthetases, antibiotic resistance, e.g., ampicillin resistance, should be about or less than that for a bacteria transformed with no plasmid. If the tRNA is not orthogonal, or if a heterologous synthetase capable of charging the tRNA is co-expressed in the system, a higher level of antibiotic, e.g., ampicillin, resistance is observed. Cells, e.g., bacteria, are chosen that are unable to grow on LB agar plates with antibiotic concentrations about equal to cells transformed with no plasmids.

[0104] In the case of a toxic product (e.g., ribonuclease or barnase), when a member of the plurality of potential tRNAs is aminoacylated by endogenous host, e.g., *Escherichia coli* synthetases (i.e., it is not orthogonal to the host, e.g., *Escherichia coli* synthetases), the selector codon is suppressed and the toxic polynucleotide product produced leads to cell death. Cells harboring orthogonal tRNAs or non-functional tRNAs survive.

[0105] In one embodiment, the pool of tRNAs that are orthogonal to a desired organism are then subjected to a positive selection in which a selector codon is placed in a positive selection marker, e.g., encoded by a drug resistance gene, such a β -lactamase gene. The positive selection is performed on a cell comprising a polynucleotide encoding or comprising a member of the pool of tRNAs that are orthogonal to the cell, a polynucleotide encoding a positive selection marker, and a polynucleotide encoding a cognate RS. In certain embodiments, the second population of cells comprises cells that were not eliminated by the negative selection. The polynucleotides are expressed in the cell and the cell is grown in the presence of a selection agent, e.g., ampicillin. tRNAs are then selected for their ability to be aminoacylated by the coexpressed cognate synthetase and to insert an amino acid in response to this selector codon. Typically, these cells show an enhancement in suppression efficiency compared to cells harboring non-functional tRNA(s), or tRNAs that cannot efficiently be recognized by the synthetase of interest. The cell harboring the non-functional tRNAs or tRNAs that are not efficiently recognized by the synthetase of interest, are sensitive to the antibiotic. Therefore, tRNAs that: (i) are not substrates for endogenous host, e.g., *Escherichia coli*, synthetases; (ii) can be aminoacylated by the synthetase of interest; and (iii) are functional in translation, survive both selections.

[0106] Accordingly, the same marker can be either a positive or negative marker, depending on the context in which it

is screened. That is, the marker is a positive marker if it is screened for, but a negative marker if screened against.

[0107] The stringency of the selection, e.g., the positive selection, the negative selection or both the positive and negative selection, in the above described-methods, optionally includes varying the selection stringency. For example, because bamase is an extremely toxic protein, the stringency of the negative selection can be controlled by introducing different numbers of selector codons into the bamase gene and/or by using an inducible promoter. In another example, the concentration of the selection or screening agent is varied (e.g., ampicillin concentration). In one aspect of the invention, the stringency is varied because the desired activity can be low during early rounds. Thus, less stringent selection criteria are applied in early rounds and more stringent criteria are applied in later rounds of selection. In certain embodiments, the negative selection, the positive selection or both the negative and positive selection can be repeated multiple times. Multiple different negative selection markers, positive selection markers or both negative and positive selection markers can be used. In certain embodiments, the positive and negative selection marker can be the same.

[0108] Other types of selections/screening can be used in the invention for producing orthogonal translational components, e.g., an O-tRNA, an O—RS, and an O-tRNA/O—RS pair that loads an unnatural amino acid such as a GalNAc amino acid in response to a selector codon. For example, the negative selection marker, the positive selection marker or both the positive and negative selection markers can include a marker that fluoresces or catalyzes a luminescent reaction in the presence of a suitable reactant. In another embodiment, a product of the marker is detected by fluorescence-activated cell sorting (FACS) or by luminescence. Optionally, the marker includes an affinity based screening marker. See also, Francisco, J. A., et al., (1993) Production and fluorescence-activated cell sorting of *Escherichia coli* expressing a functional antibody fragment on the external surface. *Proc Natl Acad Sci U S A.* 90:10444-8.

[0109] Additional methods for producing a recombinant orthogonal tRNA can be found, e.g., in International Application Publications WO 2002/086075, entitled “METHODS AND COMPOSITIONS FOR THE PRODUCTION OF ORTHOGONAL tRNA AMINOACYL-tRNA SYNTHETASE PAIRS;” WO 2004/094593, entitled “EXPANDING THE EUKARYOTIC GENETIC CODE;” and WO 2005/019415, filed Jul. 7, 2004. See also Forster et al., (2003) Programming peptidomimetic synthetases by translating genetic codes designed de novo *PNAS* 100(11):6353-6357; and, Feng et al., (2003), Expanding tRNA recognition of a tRNA synthetase by a single amino acid change, *PNAS* 100 (10): 5676-5681.

[0110] Orthogonal Aminoacyl-tRNA Synthetase (O—RS)

[0111] An O—RS of the invention preferentially aminoacylates an O-tRNA with an unnatural amino acid such as a GalNAc amino acid, for example, GalNAc- α -threonine, in vitro or in vivo. An O—RS of the invention can be provided to the translation system, e.g., a cell, by a polypeptide that includes an O—RS and/or by a polynucleotide that encodes an O—RS or a portion thereof. For example, an example O—RS comprises an amino acid sequence as set forth in the sequence listing and examples herein, or a conservative variation thereof. In another example, an O—RS, or a portion thereof, is encoded by a polynucleotide sequence that encodes an amino acid comprising sequence in the sequence

listing or examples herein, or a complementary polynucleotide sequence thereof. See, e.g., the tables and examples herein for sequences of exemplary O—RS molecules. See also, the section entitled “Nucleic Acid and Polypeptide Sequence and Variants” herein.

[0112] An O—RS of the present invention preferentially aminoacylates an O-tRNA with an unnatural amino acid that includes a saccharide moiety, either in vitro or in vivo. An O—RS of the invention can be provided to the translation system, e.g., a cell or an in vivo translation system, by a polypeptide that includes an O—RS and/or by a polynucleotide that encodes an O—RS (or a catalytic portion thereof). Amino acid sequences of exemplary orthogonal tRNA synthetases for use in the glycoprotein synthesis methods of the present invention are set forth in SEQ ID NOS.: 1-4 and 11-13. Alternatively, the O—RS, or a portion thereof, is encoded by polynucleotide comprising a polynucleotide sequence of any one of SEQ ID NO.: 6-9 and 14-16, or by other polynucleotide sequences that encodes an amino acid comprising SEQ ID NO.: 1-4 or 11-13, or a complementary polynucleotide sequence thereof.

[0113] Methods for producing an O—RS are typically based on generating a pool of mutant synthetases from the framework of a wild-type synthetase, and then selecting for mutated RSs based on their specificity for one or more selected unnatural amino acids (e.g., glycosyl-containing amino acids). The O—RS (and the O-tRNA it recognizes) can be naturally occurring or can be derived by mutation of a naturally occurring tRNA and/or RS from a variety of organisms, which are described under sources and hosts. While the O-tRNA and O—RS can be derived from the same organism, in some embodiments, the O-tRNA is derived from a naturally occurring or mutated naturally occurring tRNA from a first organism, and the O—RS is derived from naturally occurring or mutated naturally occurring RS from a second organism.

[0114] Specifically, these methods include: (a) generating a library of tRNAs derived from at least one tRNA from a first organism; (b) negatively selecting the library for tRNAs that are aminoacylated by an aminoacyl-tRNA synthetase (RS) from a second organism in the absence of a RS from the first organism, thereby providing a pool of tRNAs; (c) selecting the pool of tRNAs for members that are aminoacylated by an introduced orthogonal RS (O—RS), thereby providing at least one recombinant O-tRNA. The recombinant O-tRNA recognizes a selector codon and is not efficiency recognized by the RS from the second organism and is preferentially aminoacylated by the O—RS. The method also includes: (d) generating a library of mutant RSs derived from at least one aminoacyl-tRNA synthetase (RS) from a third organism; (e) selecting the library of RSs for members that preferentially aminoacylate the recombinant O-tRNA in the presence of an unnatural amino acid and a natural amino acid, thereby providing a pool of active RSs; and, (f) negatively selecting the pool for active RSs that preferentially aminoacylate the at least one recombinant O-tRNA in the absence of the unnatural amino acid, thereby providing the specific O-tRNA/O—RS pair, where the specific O-tRNA/O—RS pair comprises at least one recombinant O—RS that is specific for the unnatural amino acid, e.g., an unnatural amino acid that includes a saccharide moiety, and the recombinant O-tRNA.

[0115] One strategy for generating an orthogonal pair involves generating mutant libraries from which to screen and/or select an O-tRNA or O—RS. A second strategy for

generating an orthogonal tRNA/synthetase pair involves importing a heterologous tRNA/synthetase pair, e.g., importing a pair from another, e.g., source organism into the host cell. The properties of the heterologous synthetase candidate include, e.g., that it does not charge any host cell tRNA, and the properties of the heterologous tRNA candidate include, e.g., that it is not acylated by (e.g., is orthogonal to) a host cell synthetase.

[0116] Methods to generate an orthogonal aminoacyl tRNA synthetase include mutating the synthetase (e.g., at the active site in the synthetase, at the editing mechanism site in the synthetase, at different sites by combining different domains of synthetases, or the like) and applying a selection process. Typically a strategy that is based on the combination of a positive and negative selection criteria is used. During a round of positive selection, suppression of the selector codon (which has been introduced at a nonessential position(s) of a positive marker) allows cells to survive under positive selection pressure. Preferably, the selection steps are performed multiple times, e.g., at least two times, and, optionally, the concentration of the selection agent is varied. In the presence of both natural and unnatural amino acids, survivors thus encode active synthetases charging the orthogonal suppressor tRNA with either a natural or unnatural amino acid. In the absence of the unnatural amino acid (the negative selection), suppression of a selector codon, which has this time been introduced at a nonessential position(s) of a negative marker, removes synthetases with natural amino acid specificities. Survivors of both negative and positive selection encode synthetases that aminoacylate (charge) the orthogonal suppressor tRNA with unnatural amino acids only.

[0117] These synthetases can optionally be subjected to further mutagenesis, e.g., DNA shuffling, other recursive mutagenesis methods, and/or other mutagenesis techniques known in the art. For example, the mutant RSs can be generated by site-specific mutations, random point mutations, homologous recombination, chimeric construction or the like. Chimeric libraries of RSs are also included in the invention.

[0118] Additional details for producing O—RS, for altering the substrate specificity of the synthetase, and other examples of O—RSs can be found in, for example, WO 2002/086075.

[0119] Methods for identifying an orthogonal aminoacyl-tRNA synthetase (O—RS), e.g., an O—RS, for use with an O-tRNA, are a feature of the invention. For example, a method includes subjecting to selection, e.g., positive selection, a population of cells of a first species, where the cells individually comprise: 1) a member of a plurality of aminoacyl-tRNA synthetases (RSs), (e.g., the plurality of RSs can include mutant RSs, RSs derived from a species other than the first species or both mutant RSs and RSs derived from a species other than the first species); 2) the orthogonal tRNA (O-tRNA) (e.g., from one or more species); and 3) a polynucleotide that encodes an (e.g., positive) selection marker and comprises at least one selector codon. Cells are selected or screened for those that show an enhancement in suppression efficiency compared to cells lacking or with a reduced amount of the member of the plurality of RSs. Suppression efficiency can be measured by techniques known in the art and as described herein. Cells having an enhancement in suppression efficiency comprise an active RS that aminoacylates the O-tRNA. A level of aminoacylation (in vitro or in vivo) by the active RS of a first set of tRNAs from the first

species is compared to the level of aminoacylation (in vitro or in vivo) by the active RS of a second set of tRNAs from the second species. The level of aminoacylation can be determined by a detectable substance (e.g., a labeled amino acid or unnatural amino acid, e.g., a labeled GalNAc- α -threonine). The active RS that more efficiently aminoacylates the second set of tRNAs compared to the first set of tRNAs is typically selected, thereby providing an efficient (optimized) orthogonal aminoacyl-tRNA synthetase for use with the O-tRNA. An O—RS, identified by the method, is also a feature of the invention.

[0120] Any of a number of assays can be used to determine aminoacylation. These assays can be performed in vitro or in vivo. For example, in vitro aminoacylation assays are described in, e.g., Hoben and Soll (1985) *Methods Enzymol.* 113:55-59. Aminoacylation can also be determined by using a reporter along with orthogonal translation components and detecting the reporter in a cell expressing a polynucleotide comprising at least one selector codon that encodes a protein. See also, WO 2002/085923, entitled “IN VIVO INCORPORATION OF UNNATURAL AMINO ACIDS;” and WO 2004/094593, entitled “EXPANDING THE EUKARYOTIC GENETIC CODE.”

[0121] Identified O—RS can be further manipulated to alter substrate specificity of the synthetase, so that only a desired unnatural amino acid, e.g., a GalNAc amino acid, but not any of the common 20 amino acids, are charged to the O-tRNA. Methods to generate an orthogonal aminoacyl tRNA synthetase with a substrate specificity for an unnatural amino acid include mutating the synthetase, e.g., at the active site in the synthetase, at the editing mechanism site in the synthetase, at different sites by combining different domains of synthetases, or the like, and applying a selection process. A strategy is used, which is based on the combination of a positive selection followed by a negative selection. In the positive selection, suppression of the selector codon introduced at a nonessential position(s) of a positive marker allows cells to survive under positive selection pressure. In the presence of both natural and unnatural amino acids, survivors thus encode active synthetases charging the orthogonal suppressor tRNA with either a natural or unnatural amino acid. In the negative selection, suppression of a selector codon introduced at a nonessential position(s) of a negative marker removes synthetases with natural amino acid specificities. Survivors of the negative and positive selection encode synthetases that aminoacylate (charge) the orthogonal suppressor tRNA with unnatural amino acids only. These synthetases can then be subjected to further mutagenesis, e.g., DNA shuffling or other recursive mutagenesis methods.

[0122] A library of mutant O—RSs can be generated using various mutagenesis techniques known in the art. For example, the mutant RSs can be generated by site-specific mutations, random point mutations, homologous recombination, DNA shuffling or other recursive mutagenesis methods, chimeric construction or any combination thereof. For example, a library of mutant RSs can be produced from two or more other, e.g., smaller, less diverse “sub-libraries.” Chimeric libraries of RSs are also included in the invention. It should be noted that libraries of tRNA synthetases from various organism (e.g., microorganisms such as eubacteria or archaeobacteria) such as libraries that comprise natural diversity (see, e.g., U.S. Pat. No. 6,238,884 to Short et al; U.S. Pat. No. 5,756,316 to Schallenberger et al; U.S. Pat. No. 5,783,431 to Petersen et al; U.S. Pat. No. 5,824,485 to Thompson et

al; U.S. Pat. No. 5,958,672 to Short et al), are optionally constructed and screened for orthogonal pairs.

[0123] Once the synthetases are subject to the positive and negative selection/screening strategy, these synthetases can then be subjected to further mutagenesis. For example, a nucleic acid that encodes the O—RS can be isolated; a set of polynucleotides that encode mutated O—RSs (e.g., by random mutagenesis, site-specific mutagenesis, recombination or any combination thereof) can be generated from the nucleic acid; and, these individual steps or a combination of these steps can be repeated until a mutated O—RS is obtained that preferentially aminoacylates the O-tRNA with the unnatural amino acid, e.g., a GalNAc amino acid. In one aspect of the invention, the steps are performed multiple times, e.g., at least two times.

[0124] Additional levels of selection/screening stringency can also be used in the methods of the invention, for producing O-tRNA, O—RS, or pairs thereof. The selection or screening stringency can be varied on one or both steps of the method to produce an O—RS. This could include, e.g., varying the amount of selection/screening agent that is used, etc. Additional rounds of positive and/or negative selections can also be performed. Selecting or screening can also comprise one or more of a change in amino acid permeability, a change in translation efficiency, a change in translational fidelity, etc. Typically, the one or more change is based upon a mutation in one or more gene in an organism in which an orthogonal tRNA-tRNA synthetase pair is used to produce protein.

[0125] Additional general details for producing O—RS, and altering the substrate specificity of the synthetase can be found in Internal Publication Number WO 2002/086075, entitled “METHODS AND COMPOSITIONS FOR THE PRODUCTION OF ORTHOGONAL tRNA AMINOACYL-tRNA SYNTHETASE PAIRS;” and WO 2004/094593, entitled “EXPANDING THE EUKARYOTIC GENETIC CODE.”

Source and Host Organisms

[0126] The orthogonal translational components (O-tRNA and O—RS) of the invention can be derived from any organism (or a combination of organisms) for use in a host translation system from any other species, with the caveat that the O-tRNA/O—RS components and the host system work in an orthogonal manner. It is not a requirement that the O-tRNA and the O—RS be derived from the same organism. In one aspect, the orthogonal components are derived from Archaea genes (i.e., archaeobacteria) for use in a eubacterial host system.

[0127] For example, the orthogonal O-tRNA can be derived from an Archae organism, e.g., an archaeobacterium, such as *Methanococcus jannaschii*, *Methanobacterium thermoautotrophicum*, *Halobacterium* such as *Haloferax volcanii* and *Halobacterium* species NRC-1, *Archaeoglobus fulgidus*, *Pyrococcus furiosus*, *Pyrococcus horikoshii*, *Aeuropyrum pernix*, *Methanococcus maripaludis*, *Methanopyrus kandleri*, *Methanosarcina mazei* (Mm), *Pyrobaculum aerophilum*, *Pyrococcus abyssi*, *Sulfolobus solfataricus* (Ss), *Sulfolobus tokodaii*, *Thermoplasma acidophilum*, *Thermoplasma volcanium*, or the like, or a eubacterium, such as *Escherichia coli*, *Thermus thermophilus*, *Bacillus stearothermophilus*, or the like, while the orthogonal O—RS can be derived from an organism or combination of organisms, e.g., an archaeobacterium, such as *Methanococcus jannaschii*, *Methanobacterium thermoautotrophicum*, *Halobacterium* such as *Haloferax vol-*

canii and *Halobacterium* species NRC-1, *Archaeoglobus fulgidus*, *Pyrococcus furiosus*, *Pyrococcus horikoshii*, *Aeuropyrum pernix*, *Methanococcus maripaludis*, *Methanopyrus kandleri*, *Methanosarcina mazei*, *Pyrobaculum aerophilum*, *Pyrococcus abyssi*, *Sulfolobus solfataricus*, *Sulfolobus tokodaii*, *Thermoplasma acidophilum*, *Thermoplasma volcanium*, or the like, or a eubacterium, such as *Escherichia coli*, *Thermus thermophilus*, *Bacillus stearothermophilus*, or the like. In one embodiment, eukaryotic sources, e.g., plants, algae, protists, fungi, yeasts, animals (e.g., mammals, insects, arthropods, etc.), or the like, can also be used as sources of O-tRNAs and O—RSs.

[0128] The individual components of an O-tRNA/O—RS pair can be derived from the same organism or different organisms. In one embodiment, the O-tRNA/O—RS pair is from the same organism. Alternatively, the O-tRNA and the O—RS of the O-tRNA/O—RS pair are from different organisms.

[0129] The O-tRNA, O—RS or O-tRNA/O—RS pair can be selected or screened in vivo or in vitro and/or used in a cell, e.g., a eubacterial cell, to produce a polypeptide with a GalNAc amino acid. The eubacterial cell used is not limited, for example, *Escherichia coli*, *Thermus thermophilus*, *Bacillus stearothermophilus*, or the like. Compositions of eubacterial cells comprising translational components of the invention are also a feature of the invention.

[0130] See also, International Application Publication Number WO 2004/094593, entitled “EXPANDING THE EUKARYOTIC GENETIC CODE,” filed Apr. 16, 2004, for screening O-tRNA and/or O—RS in one species for use in another species.

Selector Codons

[0131] Selector codons of the invention expand the genetic codon framework of protein biosynthetic machinery for the incorporation of an unnatural amino acid, e.g., an unnatural amino acid that includes a saccharide moiety. For example, a selector codon includes, e.g., a unique three base codon, a nonsense codon, such as a stop codon, e.g., an amber codon (UAG), or an opal codon (UGA), an unnatural codon, at least a four base codon, a rare codon, or the like. A number of selector codons can be introduced into a desired gene, e.g., one or more, two or more, more than three, etc. By using different selector codons, multiple orthogonal tRNA/synthetase pairs can be used that allow the simultaneous site-specific incorporation of multiple unnatural amino acids e.g., including at least one GalNAc amino acid, using these different selector codons.

[0132] The 64 genetic codons code for 20 amino acids and three stop codons. Because only one stop codon is needed for translational termination, the other two can in principle be used to encode nonproteinogenic amino acids. The amber stop codon, UAG, has been successfully used in in vitro biosynthetic system and in *Xenopus oocytes* to direct the incorporation of unnatural amino acids. Among the three stop codons, UAG is the least used stop codon in *Escherichia coli*. Some *Escherichia coli* strains contain natural suppressor tRNAs, which recognize UAG and insert a natural amino acid. In addition, these amber suppressor tRNAs have been used in conventional protein mutagenesis. In certain embodiments of the invention, other stop codons are used in the invention.

[0133] In one embodiment, the methods and systems of the present invention involve the use of a selector codon that is a

stop codon for the incorporation of glycosyl-containing unnatural amino acids, e.g., a GalNAc amino acid, in vivo in a cell. For example, an O-tRNA is produced that recognizes the stop codon, e.g., UAG, and is aminoacylated by an O—RS with a GalNAc amino acid. This O-tRNA is not recognized by the naturally occurring host's aminoacyl-tRNA synthetases. Conventional site-directed mutagenesis can be used to introduce the stop codon at the site of interest in a polynucleotide encoding a polypeptide of interest. See, e.g., Sayers, J. R., et al. (1988), 5',3' Exonuclease in phosphorothioate-based oligonucleotide-directed mutagenesis. *Nucleic Acids Res*, 791-802. When the O—RS, O-tRNA and the nucleic acid that encodes a polypeptide of interest are combined, e.g., in vivo, the GalNAc amino acid is incorporated in response to the stop codon to give a polypeptide containing the GalNAc amino acid at the specified position. In one embodiment of the invention, the stop codon used as a selector codon is an amber codon, UAG, and/or an opal codon, UGA. In one example, a genetic code in which UAG and UGA are both used as a selector codon can encode 22 amino acids while preserving the ochre nonsense codon, UAA, which is the most abundant termination signal.

[0134] The incorporation of GalNAc amino acids in vivo can be done without significant perturbation of the host cell. For example in non-eukaryotic cells, such as *Escherichia coli*, because the suppression efficiency for the UAG codon depends upon the competition between the O-tRNA, e.g., the amber suppressor tRNA, and the release factor 1 (RF1) (which binds to the UAG codon and initiates release of the growing peptide from the ribosome), the suppression efficiency can be modulated by, e.g., either increasing the expression level of O-tRNA, e.g., the suppressor tRNA, or using an RF1 deficient strain. In eukaryotic cells, because the suppression efficiency for the UAG codon depends upon the competition between the O-tRNA, e.g., the amber suppressor tRNA, and a eukaryotic release factor (e.g., eRF) (which binds to a stop codon and initiates release of the growing peptide from the ribosome), the suppression efficiency can be modulated by, e.g., increasing the expression level of O-tRNA, e.g., the suppressor tRNA. In addition, additional compounds can also be present, e.g., reducing agents such as dithiothreitol (DTT).

[0135] GalNAc amino acids can also be encoded with rare codons. For example, when the arginine concentration in an in vitro protein synthesis reaction is reduced, the rare arginine codon, AGG, has proven to be efficient for insertion of Ala by a synthetic tRNA acylated with alanine. See, e.g., Ma et al., *Biochemistry*, 32:7939 (1993). In this case, the synthetic tRNA competes with the naturally occurring tRNA^{Arg}, which exists as a minor species in *Escherichia coli*. In addition, some organisms do not use all triplet codons. An unassigned codon AGA in *Micrococcus luteus* has been utilized for insertion of amino acids in an in vitro transcription/translation extract. See, e.g., Kowal and Oliver, *Nucl. Acid. Res.*, 25:4685 (1997). Components of the invention can be generated to use these rare codons in vivo.

[0136] Selector codons can also comprise extended codons, e.g., four or more base codons, such as, four, five, six or more base codons. Examples of four base codons include, e.g., AGGA, CUAG, UAGA, CCCU, and the like. Examples of five base codons include, e.g., AGGAC, CCCCUC, CCCUC, CUAGA, CUACU, UAGGC and the like. Methods of the invention include using extended codons based on frameshift suppression. Four or more base codons can insert, e.g., one or multiple unnatural amino acids such as a GalNAc amino acid,

into the same protein. In other embodiments, the anticodon loops can decode, e.g., at least a four-base codon, at least a five-base codon, or at least a six-base codon or more. Since there are 256 possible four-base codons, multiple unnatural amino acids can be encoded in the same cell using a four or more base codon. See also, Anderson et al., (2002) Exploring the Limits of Codon and Anticodon Size, *Chemistry and Biology*, 9:237-244; and, Magliery, (2001) Expanding the Genetic Code: Selection of Efficient Suppressors of Four-base Codons and Identification of "Shifty" Four-base Codons with a Library Approach in *Escherichia coli*, *J. Mol. Biol.* 307: 755-769.

[0137] Methods of the invention include using extended codons based on frameshift suppression. Four or more base codons can insert, e.g., one or multiple unnatural amino acids into the same protein. For example, four-base codons have been used to incorporate unnatural amino acids into proteins using in vitro biosynthetic methods. See, e.g., Ma et al., (1993) *Biochemistry*, 32:7939; and Hohsaka et al., (1999) *J. Am. Chem. Soc.*, 121:34. CGGG and AGGU were used to simultaneously incorporate 2-naphthylalanine and an NBD derivative of lysine into streptavidin in vitro with two chemically acylated frameshift suppressor tRNAs. See, e.g., Hohsaka et al., (1999) *J. Am. Chem. Soc.*, 121:12194. In an in vivo study, Moore et al. examined the ability of tRNA^{Leu} derivatives with NCUA anticodons to suppress UAGN codons (N can be U, A, G, or C), and found that the quadruplet UAGA can be decoded by a tRNA^{Leu} with a UCUA anticodon with an efficiency of 13 to 26% with little decoding in the 0 or -1 frame. See Moore et al., (2000) *J. Mol. Biol.*, 298:195. In one embodiment, extended codons based on rare codons or nonsense codons can be used in invention, which can reduce missense readthrough and frameshift suppression at other unwanted sites.

[0138] For a given system, a selector codon can also include one of the natural three base codons, where the endogenous system does not use (or rarely uses) the natural base codon. For example, this includes a system that is lacking a tRNA that recognizes the natural three base codon, and/or a system where the three base codon is a rare codon.

[0139] Selector codons optionally include unnatural base pairs. These unnatural base pairs further expand the existing genetic alphabet. One extra base pair increases the number of triplet codons from 64 to 125. Properties of third base pairs include stable and selective base pairing, efficient enzymatic incorporation into DNA with high fidelity by a polymerase, and the efficient continued primer extension after synthesis of the nascent unnatural base pair. Descriptions of unnatural base pairs which can be adapted for methods and compositions include, e.g., Hirao, et al., (2002) An unnatural base pair for incorporating amino acid analogues into protein, *Nature Biotechnology*, 20:177-182. See also Wu, Y., et al., (2002) *J. Am. Chem. Soc.* 124:14626-14630. Other relevant publications are listed below.

[0140] For in vivo usage, the unnatural nucleoside is membrane permeable and is phosphorylated to form the corresponding triphosphate. In addition, the increased genetic information is stable and not destroyed by cellular enzymes. Previous efforts by Benner and others took advantage of hydrogen bonding patterns that are different from those in canonical Watson-Crick pairs, the most noteworthy example of which is the iso-C:iso-G pair. See, e.g., Switzer et al., (1989) *J. Am. Chem. Soc.*, 111:8322; and Piccirilli et al., (1990) *Nature*, 343:33; Kool, (2000) *Curr. Opin. Chem. Biol.*,

4:602. These bases in general mispair to some degree with natural bases and cannot be enzymatically replicated. Kool and co-workers demonstrated that hydrophobic packing interactions between bases can replace hydrogen bonding to drive the formation of base pair. See Kool, (2000) *Curr. Opin. Chem. Biol.*, 4:602; and Guckian and Kool, (1998) *Angew. Chem. Int. Ed. Engl.*, 36, 2825. In an effort to develop an unnatural base pair satisfying all the above requirements, Schultz, Romesberg and co-workers have systematically synthesized and studied a series of unnatural hydrophobic bases. A PICS:PICS self-pair is found to be more stable than natural base pairs, and can be efficiently incorporated into DNA by Klenow fragment of *Escherichia coli* DNA polymerase I (KF). See, e.g., McMinn et al., (1999) *J. Am. Chem. Soc.*, 121:11586; and Ogawa et al., (2000) *J. Am. Chem. Soc.*, 122:3274. A 3MN:3MN self-pair can be synthesized by KF with efficiency and selectivity sufficient for biological function. See, e.g., Ogawa et al., (2000) *J. Am. Chem. Soc.*, 122:8803. However, both bases act as a chain terminator for further replication. A mutant DNA polymerase has been recently evolved that can be used to replicate the PICS self pair. In addition, a 7AI self pair can be replicated. See, e.g., Tae et al., (2001) *J. Am. Chem. Soc.*, 123:7439. A novel metalbase pair, Dipic:Py, has also been developed, which forms a stable pair upon binding Cu(II). See Meggers et al., (2000) *J. Am. Chem. Soc.*, 122:10714. Because extended codons and unnatural codons are intrinsically orthogonal to natural codons, the methods of the invention can take advantage of this property to generate orthogonal tRNAs for them.

[0141] A translational bypassing system can also be used to incorporate an unnatural amino acid that includes a saccharide moiety, e.g., a GalNAc amino acid, in a desired polypeptide. In a translational bypassing system, a large sequence is inserted into a gene but is not translated into protein. The sequence contains a structure that serves as a cue to induce the ribosome to hop over the sequence and resume translation downstream of the insertion.

[0142] Alternatively, or in combination with others methods described above to incorporate an unnatural amino acid that includes a saccharide moiety into a polypeptide, a trans-translation system can be used. This system involves a molecule called tmRNA present in *Escherichia coli*. This RNA molecule is structurally related to an alanyl tRNA and is aminoacylated by the alanyl synthetase. The difference between tmRNA and tRNA is that the anticodon loop is replaced with a special large sequence. This sequence allows the ribosome to resume translation on sequences that have stalled using an open reading frame encoded within the tmRNA as template. In the invention, an orthogonal tmRNA can be generated that is preferentially aminoacylated with an orthogonal synthetase and loaded with an unnatural amino acid. By transcribing a gene using the system, the ribosome stalls at a specific site; the unnatural amino acid is introduced at that site, then translation resumes, using the sequence encoded within the orthogonal tmRNA.

Unnatural Amino Acids

[0143] As used herein, an unnatural amino acid refers to any amino acid, modified amino acid, or amino acid analogue other than selenocysteine and/or pyrrolysine and the following twenty genetically encoded alpha-amino acids: alanine, arginine, asparagine, aspartic acid, cysteine, glutamine, glutamic acid, glycine, histidine, isoleucine, leucine, lysine, methionine, phenylalanine, proline, serine, threonine, tryptophan,

tyrosine, valine. The generic structure of an alpha-amino acid is illustrated by Formula I:

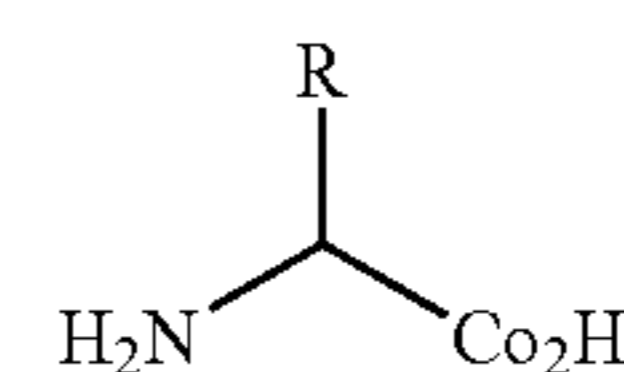

I

[0144] An unnatural amino acid is typically any structure having Formula I wherein the R group is any substituent other than one used in the twenty natural amino acids. See e.g., *Biochemistry* by L. Stryer, 3rd ed. 1988, Freeman and Company, New York, for structures of the twenty natural amino acids. Note that, the unnatural amino acids of the invention can be naturally occurring compounds other than the twenty alpha-amino acids above.

[0145] Because the unnatural amino acids of the invention typically differ from the natural amino acids in side chain, the unnatural amino acids form amide bonds with other amino acids, e.g., natural or unnatural, in the same manner in which they are formed in naturally occurring proteins. However, the unnatural amino acids have side chain groups that distinguish them from the natural amino acids.

[0146] Of particular interest herein are unnatural amino acids that comprise a N-acetylgalactosamine moiety. For example, in a GalNAc amino acid, R in Formula I includes any N-acetylgalactosamine-containing structure. For example, N-acetylgalactosamine- α -threonine, a triacetyl-N-acetylgalactosamine- α -threonine, an N-acetylgalactosamine- α -serine, and a triacetyl-N-acetylgalactosamine- α -serine find use with the invention. It is not intended that the invention be limited to systems that incorporate N-acetylgalactosamine- α -threonine species. For example, a variety of other GalNAc amino acids are contemplated (see e.g., Table 1).

[0147] In other unnatural amino acids, for example, R in Formula I optionally comprises an alkyl-, aryl-, acyl-, hydrazine, cyano-, halo-, hydrazide, alkenyl, ether, borate, boronate, phospho, phosphono, phosphine, enone, imine, ester, hydroxylamine, amine, and the like, or any combination thereof. Other unnatural amino acids of interest include, but are not limited to, amino acids comprising a photoactivatable cross-linker, spin-labeled amino acids, fluorescent amino acids, metal binding amino acids, metal-containing amino acids, radioactive amino acids, amino acids with novel functional groups, amino acids that covalently or noncovalently interact with other molecules, photocaged and/or photoisomerizable amino acids, biotin or biotin-analogue containing amino acids, keto containing amino acids, glycosylated amino acids, a saccharide moiety attached to the amino acid side chain, amino acids comprising polyethylene glycol or polyether, heavy atom substituted amino acids, chemically cleavable or photocleavable amino acids, amino acids with an elongated side chain as compared to natural amino acids (e.g., polyethers or long chain hydrocarbons, e.g., greater than about 5, greater than about 10 carbons, etc.), carbon-linked sugar-containing amino acids, amino thioacid containing amino acids, and amino acids containing one or more toxic moiety.

[0148] In another aspect, the invention provides GalNAc amino acids having the general structure illustrated by Formula IV below:

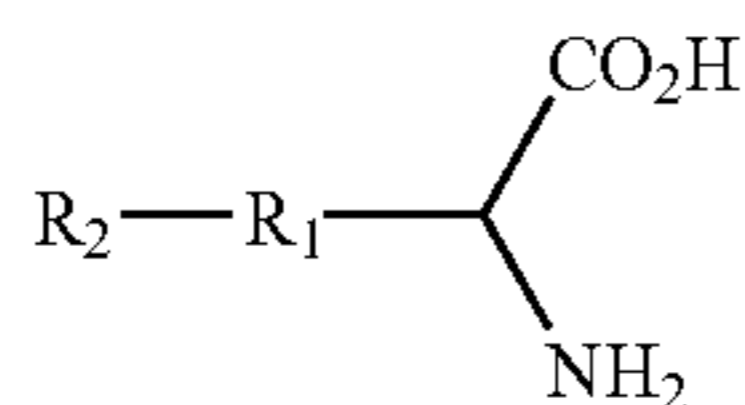

IV

[0149] A GalNAc amino acid having this structure is typically any structure where R_1 is a substituent used in one of the twenty natural amino acids and R_2 is a GalNAc substituent. Thus, this type of amino acid can be viewed as a natural amino acid derivative.

[0150] As stated above, it is not intended that the invention be limited to the use of the unnatural amino acid N-acetylgalactosamine- α -threonine. Indeed, any GalNAc amino acid that can be used in an orthogonal translation system of the invention in a eubacteria is within the scope of the invention.

[0151] In addition to unnatural amino acids that contain novel side chains such as the GalNAc group, unnatural GalNAc amino acids can also optionally comprise modified backbone structures, e.g., as illustrated by the structures of Formula II and III:

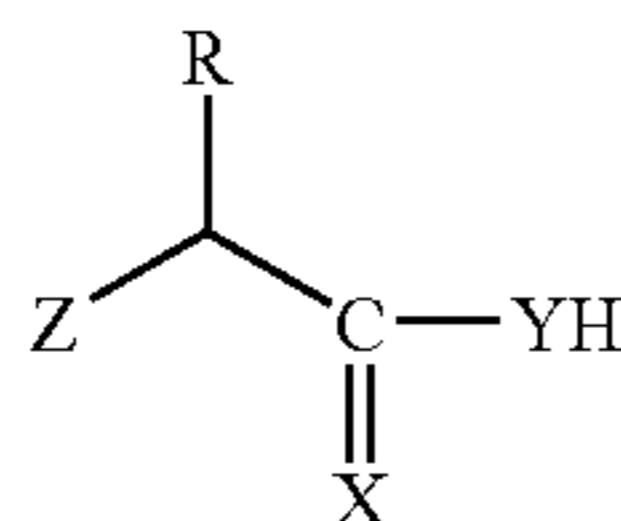

II

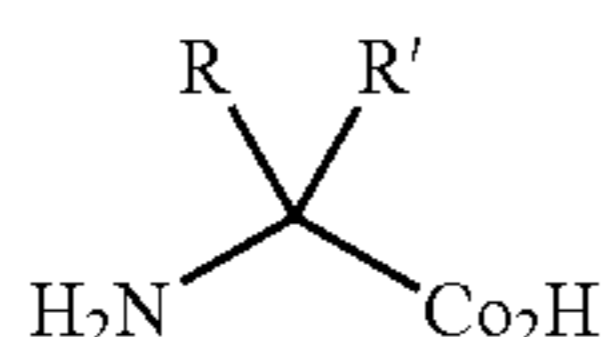

III

wherein Z typically comprises OH, NH_2 , SH, $\text{NH}-\text{R}'$, or $\text{S}-\text{R}'$; X and Y, which can be the same or different, typically comprise S or O, and R and R' , which are optionally the same or different, are typically selected from the same list of constituents for the R group described above for the unnatural amino acids having Formula I as well as hydrogen. For example, unnatural amino acids of the invention optionally comprise substitutions in the amino or carboxyl group as illustrated by Formulas II and III. Unnatural amino acids of this type include, but are not limited to, α -hydroxy acids, α -thioacids α -aminothiocarboxylates, e.g., with side chains corresponding to the common twenty natural amino acids or unnatural GalNAc side chains. In addition, substitutions at the α -carbon optionally include L, D, or α - α -disubstituted amino acids such as D-glutamate, D-alanine, D-methyl-O-tyrosine, aminobutyric acid, and the like. Other structural alternatives include cyclic amino acids, such as proline analogues as well as 3, 4, 6, 7, 8, and 9 membered ring proline analogues, β and γ amino acids such as substituted β -alanine and γ -amino butyric acid.

[0152] Tyrosine analogs include para-substituted tyrosines, ortho-substituted tyrosines, and meta substituted tyrosines, wherein the substituted tyrosine comprises a GalNAc group, an alkynyl group, acetyl group, a benzoyl group, an amino group, a hydrazine, an hydroxyamine, a thiol group, a carboxy group, an isopropyl group, a methyl group, a C_6 - C_{20} straight chain or branched hydrocarbon, a saturated or unsaturated hydrocarbon, an O-methyl group, a polyether group, a nitro group, or the like. In addition, multiply substituted aryl

groups are also contemplated. Glutamine analogs of the invention include, but are not limited to, α -hydroxy derivatives, γ -substituted derivatives, cyclic derivatives, and amide substituted glutamine derivatives. Example phenylalanine analogs include, but are not limited to, para-substituted phenylalanines, ortho-substituted phenylalanines, and meta-substituted phenylalanines, wherein the substituent comprises an alkynyl group, a hydroxy group, a methoxy group, a methyl group, an allyl group, an aldehyde, a nitro, a thiol group, or keto group, or the like. Specific examples of unnatural amino acids include, but are not limited to, a GalNAc- α -threonine, a p-propargyloxyphenylalanine, a 3,4-dihydroxy-L-phenylalanine (DHP), a 3,4,6-trihydroxy-L-phenylalanine, a 3,4,5-trihydroxy-L-phenylalanine, 4-nitrophenylalanine, a p-acetyl-L-phenylalanine, O-methyl-L-tyrosine, an L-3-(2-naphthyl)alanine, a 3-methylphenylalanine, an O-4-allyl-L-tyrosine, a 4-propyl-L-tyrosine, a 3-nitro-tyrosine, a 3-thiol-tyrosine, a tri-O-acetyl-GlcNAc β -serine, an L-Dopa, a fluorinated phenylalanine, an isopropyl-L-phenylalanine, a p-azido-L-phenylalanine, a p-acyl-L-phenylalanine, a p-benzoyl-L-phenylalanine, an L-phosphoserine, a phosphoserine, a phosphotyrosine, a p-iodo-phenylalanine, a p-bromophenylalanine, a p-amino-L-phenylalanine, and an isopropyl-L-phenylalanine, and the like. The structures of a variety of unnatural GalNAc amino acids are provided herein.

[0153] Of particular interest for making glycoproteins of the invention are unnatural amino acids in which R in Formula I includes a saccharide (glycosyl) moiety as part of the side chain. Exemplary glycosyl-containing unnatural amino acids include, but are not limited to, GalNAc- α -O-threonine, GalNAc- α -O-serine, and GlcNAc- α -O-serine, as well as the corresponding protected versions (e.g., containing one or more acetylated hydroxyl residues) and thiol analogs (in which the anomeric O is replaced with S).

[0154] The glycosyl-containing unnatural amino acids suitable for use in the compositions and methods of the invention typically include a saccharide moiety attached to the amino acid side chain, and include, but are not limited to, both protected (e.g., acetylated) and "deprotected" compositions. In one embodiment, an unnatural amino acid with a saccharide moiety includes a serine or threonine amino acid with a Man, GalNAc, Glc, GlcNAc, Fuc, or Gal moiety.

[0155] Exemplary unnatural amino acids that include a saccharide moiety include, but are not limited to, e.g., a tri-O-acetyl-GlcNAc β -serine, a β -O-GlcNAc-L-serine, a tri-O-acetyl-GalNAc- α -threonine, an α -GalNAc-L-threonine, an O-Man-L-serine, a tetra-acetyl-O-Man-L-serine, an O-GalNAc-L-serine, a tri-acetyl-O-GalNAc-L-serine, a Glc-L-serine, a tetraacetyl-Glc-L-serine, a fuc-L-serine, a tri-acetyl-fuc-L-serine, an O-Gal-L-serine, a tetra-acetyl-O-Gal-L-serine, a beta-O-GlcNAc-L-threonine, a tri-acetyl-beta-GlcNAc-L-threonine, an O-Man-L-threonine, a tetra-acetyl-O-Man-L-threonine, an O-GalNAc-L-threonine, a tri-acetyl-O-GalNAc-L-threonine, a Glc-L-threonine, a tetraacetyl-Glc-L-threonine, a fuc-L-threonine, a tri-acetyl-fuc-L-threonine, an O-Gal-L-threonine, a tetra-acetyl-O-Gal-L-serine, and the like. The glycosyl-containing compositions of the present invention include both unprotected and protected (e.g., acetylated) forms of the above. Additional and/or alternative protecting groups known to one of skill in the art, such as t-butyl moieties, Fmoc protecting groups, phenyl groups, and the like, can optionally be present on one or more hydroxyl or amine portions of the glycosyl-containing

unnatural amino acid. Exemplary glycosyl amino acids are provided in Table 1. See also WO 2003/031464A2, entitled "Remodeling and Glycoconjugation of Peptides"; and, U.S. Pat. No. 6,331,418, entitled "Saccharide Compositions, Methods and Apparatus for their synthesis."

TABLE 1

GLYCOSYL UNNATURAL AMINO ACIDS	
Unnatural Amino Acid	Structure
1 GalNAc- α -O-threonine	
2 peracetylated GalNAc- α -O-threonine	
3 GalNAc- α -O-serine	
4 peracetylated GalNAc- α -O-serine	

TABLE 1-continued

GLYCOSYL UNNATURAL AMINO ACIDS	
Unnatural Amino Acid	Structure
5 GlcNAc- β -O-serine	
6 peracetylated GlcNAc- β -O-serine	
7 GalNAc- α -S-threonine	
8 peracetylated GalNAc- α -S-threonine	

TABLE 1-continued

GLYCOSYL UNNATURAL AMINO ACIDS	
Unnatural Amino Acid	Structure
9 GalNAc- α -S-serine	
10 peracetylated GalNAc- α -S-serine	
11 GlcNAc- β -S-serine	
12 peracetylated GlcNAc- β -S-serine	

[0156] Chemical Synthesis of Unnatural Amino Acids

[0157] Some glycosyl-containing unnatural amino acids provided herein are commercially available, e.g., from Sigma-Aldrich (Milwaukee, Wis., USA), Sussex Research Laboratories Inc. (Ottawa, Calif.), V-Labs, Inc. (Covington, La.), or other providers of amino acids used, e.g., in solid-phase peptide synthesis schemes. Those that are not commercially available are optionally synthesized as provided in the examples below or using standard methods known to those of

skill in the art. For organic synthesis techniques, see, e.g., *Organic Chemistry* by Fessenden and Fessenden, (1982, Second Edition, Willard Grant Press, Boston Mass.); *Advanced Organic Chemistry* by March (Third Edition, 1985, Wiley and Sons, New York); and *Advanced Organic Chemistry* by Carey and Sundberg (Third Edition, Parts A and B, 1990, Plenum Press, New York). See also WO 2002/085923 for additional synthesis of unnatural amino acids.

[0158] For example, peracetylated N-acetylgalactosamine- α -O-threonine 2 can be synthesized in a procedure substantially as outlined in Koeller et al. (2000) *Bioorganic & Medicinal Chemistry* 8:1017-1025, and as depicted in FIG. 2. Galactosamine HCl 13 was used to generate the peracetylated azide intermediate 14, which was selectively deacetylated at the anomeric position and converted to the trichloroacetimide derivative 15. Activation of the resulting anomeric mixture of 15 with trimethylsilyl trifluoromethanesulfonate (TM-SOTf) in dichloromethane:diethyl ether (1:1) at -30° C. provided intermediate 17 as predominantly the α -anomer. Deprotection of the amino and carbonyl moieties provided peracetylated N-acetylgalactosamine- α -O-threonine 2.

[0159] Additional publications describing the synthesis of unnatural amino acids include, Matsoukas et al., (1995) *J. Med. Chem.*, 38, 4660-4669; King, F. E. & Kidd, D. A. A. (1949) A New Synthesis of Glutamine and of γ -Dipeptides of Glutamic Acid from Phthylated Intermediates. *J. Chem. Soc.* 3315-3319; Friedman, O. M. & Chatterji, R. (1959) Synthesis of Derivatives of Glutamine as Model Substrates for Anti-Tumor Agents. *J. Am. Chem. Soc.* 81, 3750-3752; Craig, J. C. et al. (1988) Absolute Configuration of the Enantiomers of 7-Chloro-4[[4-(diethylamino)-1-methylbutyl]amino]quinoline (Chloroquine). *J. Org. Chem.* 53, 1167-1170; Azoulay, M., Vilmont, M. & Frappier, F. (1991) Glutamine analogues as Potential Antimalarials. *Eur. J. Med. Chem.* 26, 201-5; Koskinen, A. M. P. & Rapoport, H. (1989) Synthesis of 4-Substituted Prolines as Conformationally Constrained Amino Acid Analogues. *J. Org. Chem.* 54, 1859-1866; Christie, B. D. & Rapoport, H. (1985) Synthesis of Optically Pure Pipecolates from L-Asparagine. Application to the Total Synthesis of (+)-Apovincamine through Amino Acid Decarboxylation and Iminium Ion Cyclization. *J. Org. Chem.* 1989: 1859-1866; Barton et al., (1987) Synthesis of Novel α -Amino-Acids and Derivatives Using Radical Chemistry: Synthesis of L- and D- α -Amino-Adipic Acids, L- α -aminopimelic Acid and Appropriate Unsaturated Derivatives. *Tetrahedron Lett.* 43:4297-4308; and, Subasinghe et al., (1992) Quisqualic acid analogues: synthesis of beta-heterocyclic 2-aminopropanoic acid derivatives and their activity at a novel quisqualate-sensitized site. *J. Med. Chem.* 35:4602-7. See also International Publication WO 2004/058946, entitled "PROTEIN ARRAYS," filed on Dec. 22, 2003.

[0160] Cellular Uptake of Unnatural Amino Acids

[0161] Unnatural amino acid uptake by a cell is one issue that is typically considered when designing and selecting unnatural amino acids, e.g., for incorporation into a protein. For example, the high charge density of α -amino acids suggests that these compounds are unlikely to be cell permeable. Natural amino acids are taken up into the cell via a collection of protein-based transport systems often displaying varying degrees of amino acid specificity. A rapid screen can be done which assesses which unnatural amino acids, if any, are taken up by cells. See, e.g., the toxicity assays in, e.g., International Publication WO 2004/058946, entitled "PROTEIN ARRAYS," filed on Dec. 22, 2003; and Liu and Schultz

(1999) Progress toward the evolution of an organism with an expanded genetic code. *PNAS* 96:4780-4785. Although uptake is easily analyzed with various assays, an alternative to designing unnatural amino acids that are amenable to cellular uptake pathways is to provide biosynthetic pathways to create amino acids in vivo.

[0162] Biosynthesis of Unnatural Amino Acids

[0163] Many biosynthetic pathways already exist in cells for the production of amino acids and other compounds. While a biosynthetic method for a particular unnatural amino acid may not exist in nature, e.g., in a cell, the invention provides such methods. For example, biosynthetic pathways for unnatural amino acids are optionally generated in host cell by adding new enzymes or modifying existing host cell pathways. Additional new enzymes are optionally naturally occurring enzymes or artificially evolved enzymes. For example, the biosynthesis of p-aminophenylalanine (as presented in an example in WO 2002/085923, supra) relies on the addition of a combination of known enzymes from other organisms. The genes for these enzymes can be introduced into a cell by transforming the cell with a plasmid comprising the genes. The genes, when expressed in the cell, provide an enzymatic pathway to synthesize the desired compound. Examples of the types of enzymes that are optionally added are provided in the examples below. Additional enzymes sequences are found, e.g., in Genbank. Artificially evolved enzymes are also optionally added into a cell in the same manner. In this manner, the cellular machinery and resources of a cell are manipulated to produce unnatural amino acids.

[0164] Indeed, any of a variety of methods can be used for producing novel enzymes for use in biosynthetic pathways, or for evolution of existing pathways, for the production of unnatural amino acids, in vitro or in vivo. Many available methods of evolving enzymes and other biosynthetic pathway components can be applied to the present invention to produce unnatural amino acids (or, indeed, to evolve synthetases to have new substrate specificities or other activities of interest). For example, DNA shuffling is optionally used to develop novel enzymes and/or pathways of such enzymes for the production of unnatural amino acids (or production of new synthetases), in vitro or in vivo. See, e.g., Stemmer (1994), Rapid evolution of a protein in vitro by DNA shuffling, *Nature* 370(4):389-391; and, Stemmer, (1994), DNA shuffling by random fragmentation and reassembly: In vitro recombination for molecular evolution, *Proc. Natl. Acad. Sci. USA*, 91:10747-10751. A related approach shuffles families of related (e.g., homologous) genes to quickly evolve enzymes with desired characteristics. An example of such "family gene shuffling" methods is found in Cramer et al. (1998) "DNA shuffling of a family of genes from diverse species accelerates directed evolution" *Nature*, 391(6664): 288-291. New enzymes (whether biosynthetic pathway components or synthetases) can also be generated using a DNA recombination procedure known as "incremental truncation for the creation of hybrid enzymes" ("ITCHY"), e.g., as described in Ostermeier et al. (1999) "A combinatorial approach to hybrid enzymes independent of DNA homology" *Nature Biotech* 17:1205. This approach can also be used to generate a library of enzyme or other pathway variants which can serve as substrates for one or more in vitro or in vivo recombination methods. See, also, Ostermeier et al. (1999) "Combinatorial Protein Engineering by Incremental Truncation," *Proc. Natl. Acad. Sci. USA*, 96: 3562-67, and Ostermeier et al. (1999), "Incremental Truncation as a Strategy in

the Engineering of Novel Biocatalysts," *Biological and Medicinal Chemistry*, 7: 2139-44. Another approach uses exponential ensemble mutagenesis to produce libraries of enzyme or other pathway variants that are, e.g., selected for an ability to catalyze a biosynthetic reaction relevant to producing an unnatural amino acid (or a new synthetase). In this approach, small groups of residues in a sequence of interest are randomized in parallel to identify, at each altered position, amino acids which lead to functional proteins. Examples of such procedures, which can be adapted to the present invention to produce new enzymes for the production of unnatural amino acids (or new synthetases) are found in Delegrave & Youvan (1993) *Biotechnology Research* 11: 1548-1552. In yet another approach, random or semi-random mutagenesis using doped or degenerate oligonucleotides for enzyme and/or pathway component engineering can be used, e.g., by using the general mutagenesis methods of e.g., Arkin and Youvan (1992) "Optimizing nucleotide mixtures to encode specific subsets of amino acids for semi-random mutagenesis" *Biotechnology* 10:297-300; or Reidhaar-Olson et al. (1991) "Random mutagenesis of protein sequences using oligonucleotide cassettes" *Methods Enzymol.* 208:564-86. Yet another approach, often termed a "non-stochastic" mutagenesis, which uses polynucleotide reassembly and site-saturation mutagenesis can be used to produce enzymes and/or pathway components, which can then be screened for an ability to perform one or more synthetase or biosynthetic pathway function (e.g., for the production of unnatural amino acids in vivo). See, e.g., Short "NON-STOCHASTIC GENERATION OF GENETIC VACCINES AND ENZYMES" WO 00/46344.

[0165] An alternative to such mutational methods involves recombining entire genomes of organisms and selecting resulting progeny for particular pathway functions (often referred to as "whole genome shuffling"). This approach can be applied to the present invention, e.g., by genomic recombination and selection of an organism (e.g., an *E. coli* or other cell) for an ability to produce an unnatural amino acid (or intermediate thereof). For example, methods taught in the following publications can be applied to pathway design for the evolution of existing and/or new pathways in cells to produce unnatural amino acids in vivo: Patnaik et al. (2002) "Genome shuffling of lactobacillus for improved acid tolerance" *Nature Biotechnology*, 20(7): 707-712; and Zhang et al. (2002) "Genome shuffling leads to rapid phenotypic improvement in bacteria" *Nature*, February 7, 415(6872): 644-646.

[0166] Other techniques for organism and metabolic pathway engineering, e.g., for the production of desired compounds are also available and can also be applied to the production of unnatural amino acids. Examples of publications teaching useful pathway engineering approaches include: Nakamura and White (2003) "Metabolic engineering for the microbial production of 1,3 propanediol" *Curr. Opin. Biotechnol.* 14(5):454-9; Berry et al. (2002) "Application of Metabolic Engineering to improve both the production and use of Biotech Indigo" *J. Industrial Microbiology and Biotechnology* 28:127-133; Banta et al. (2002) "Optimizing an artificial metabolic pathway: Engineering the cofactor specificity of Corynebacterium 2,5-diketo-D-gluconic acid reductase for use in vitamin C biosynthesis" *Biochemistry*, 41(20), 6226-36; Selivonova et al. (2001) "Rapid Evolution of Novel Traits in Microorganisms" *Applied and Environmental Microbiology*, 67:3645, and many others.

[0167] Regardless of the method used, typically, the unnatural amino acid produced with an engineered biosynthetic pathway of the invention is produced in a concentration sufficient for efficient protein biosynthesis, e.g., a natural cellular amount, but not to such a degree as to significantly affect the concentration of other cellular amino acids or to exhaust cellular resources. Typical concentrations produced in vivo in this manner are about 10 mM to about 0.05 mM. Once a cell is engineered to produce enzymes desired for a specific pathway and an unnatural amino acid is generated, in vivo selections are optionally used to further optimize the production of the unnatural amino acid for both ribosomal protein synthesis and cell growth.

[0168] Orthogonal Components for Incorporating GalNAc- α -threonine

[0169] The invention provides compositions and methods of producing orthogonal components for incorporating GalNAc amino acids, e.g., GalNAc- α -threonine, into a growing polypeptide chain in response to a selector codon, e.g., an amber stop codon, a nonsense codon, a four or more base codon, etc., e.g., in vivo. For example, the invention provides orthogonal-tRNAs (O-tRNAs), orthogonal aminoacyl-tRNA synthetases (O-RSs) and pairs thereof. These pairs can be used to incorporate GalNAc- α -threonine into growing polypeptide chains.

[0170] A composition of the invention includes an orthogonal aminoacyl-tRNA synthetase (O-RS), where the O-RS preferentially aminoacylates an O-tRNA with a GalNAc- α -threonine. In certain embodiments, the O-RS comprises an amino acid sequence comprising SEQ ID NOs: 1, 2, 3 or 4, or a conservative variant thereof. In certain embodiments of the invention, the O-RS preferentially aminoacylates the O-tRNA over any endogenous tRNA with the GalNAc amino acid, where the O-RS has a bias for the O-tRNA, and where the ratio of O-tRNA charged with the GalNAc amino acid to the endogenous tRNA charged with the GalNAc amino acid is greater than 1:1, and more preferably where the O-RS charges the O-tRNA exclusively or nearly exclusively.

[0171] A composition that includes an O-RS can optionally further include an orthogonal tRNA (O-tRNA), where the O-tRNA recognizes a selector codon. Typically, an O-tRNA of the invention includes at least about, e.g., a 45%, a 50%, a 60%, a 75%, an 80%, or a 90% or more suppression efficiency in the presence of a cognate synthetase in response to a selector codon as compared to the suppression efficiency of an O-tRNA comprising or encoded by a polynucleotide sequence as set forth in the sequence listings (e.g., SEQ ID NO: 17) and examples herein. In one embodiment, the suppression efficiency of the O-RS and the O-tRNA together is, e.g., 5 fold, 10 fold, 15 fold, 20 fold, 25 fold or more greater than the suppression efficiency of the O-tRNA in the absence of an O-RS. In one aspect, the suppression efficiency of the O-RS and the O-tRNA together is at least 45% of the suppression efficiency of an orthogonal tyrosyl-tRNA synthetase pair derived from *Methanococcus jannaschii*.

[0172] A composition that includes an O-tRNA can optionally include a cell (e.g., a eubacterial cell, such as an *E. coli* cell and the like), and/or a translation system.

[0173] A cell (e.g., a eubacterial cell) comprising a translation system is also provided by the invention, where the translation system includes an orthogonal-tRNA (O-tRNA); an orthogonal aminoacyl-tRNA synthetase (O-RS); and, a GalNAc amino acid. Typically, the O-RS preferentially aminoacylates the O-tRNA over any endogenous tRNA with

a GalNAc amino acid, where the O-RS has a bias for the O-tRNA, and where the ratio of O-tRNA charged with the GalNAc amino acid to the endogenous tRNA charged with the same amino acid is greater than 1:1, and more preferably where the O-RS charges the O-tRNA exclusively or nearly exclusively. The O-tRNA recognizes the first selector codon, and the O-RS preferentially aminoacylates the O-tRNA with the GalNAc amino acid. In one embodiment, the O-tRNA comprises or is encoded by a polynucleotide sequence as set forth in SEQ ID NO: 17, or a complementary polynucleotide sequence thereof. In one embodiment, the O-RS comprises an amino acid sequence as set forth in any one of SEQ ID NO: 1, 2, 3, 4 or a conservative variation thereof.

[0174] A cell of the invention can optionally further comprise an additional different O-tRNA/O-RS pair and a second unnatural amino acid, e.g., where this O-tRNA recognizes a second selector codon and this O-RS preferentially aminoacylates the corresponding O-tRNA with the second unnatural amino acid, where the second amino acid is different from the GalNAc amino acid. Optionally, a cell of the invention includes a nucleic acid that comprises a polynucleotide that encodes a polypeptide of interest, where the polynucleotide comprises a selector codon that is recognized by the O-tRNA.

[0175] In certain embodiments, a cell of the invention is a eubacterial cell such as *E. coli*, that includes an orthogonal-tRNA (O-tRNA), an orthogonal aminoacyl-tRNA synthetase (O-RS), an GalNAc amino acid such as a GalNAc- α -threonine, and a nucleic acid that comprises a polynucleotide that encodes a polypeptide of interest, where the polynucleotide comprises the selector codon that is recognized by the O-tRNA. In certain embodiments of the invention, the O-RS preferentially aminoacylates the O-tRNA with an efficiency that is greater than the efficiency with which the O-RS aminoacylates any endogenous tRNA.

[0176] In certain embodiments of the invention, an O-tRNA of the invention comprises or is encoded by a polynucleotide sequence as set forth in the sequence listings (e.g., SEQ ID NO: 17) or examples herein, or a complementary polynucleotide sequence thereof. In certain embodiments of the invention, an O-RS comprises an amino acid sequence as set forth in the sequence listings, or a conservative variation thereof. In one embodiment, the O-RS or a portion thereof is encoded by a polynucleotide sequence encoding an amino acid as set forth in the sequence listings or examples herein, or a complementary polynucleotide sequence thereof.

[0177] The O-tRNA and/or the O-RS of the invention can be derived from any of a variety of organisms (e.g., eukaryotic and/or non-eukaryotic organisms).

[0178] Polynucleotides are also a feature of the invention. A polynucleotide of the invention includes an artificial (e.g., man-made, and not naturally occurring) polynucleotide comprising a nucleotide sequence encoding a polypeptide as set forth in the sequence listings herein, and/or is complementary to or that polynucleotide sequence. A polynucleotide of the invention can also include a nucleic acid that hybridizes to a polynucleotide described above, under highly stringent conditions, over substantially the entire length of the nucleic acid. A polynucleotide of the invention also includes a polynucleotide that is, e.g., at least 75%, at least 80%, at least 90%, at least 95%, at least 98% or more identical to that of a naturally occurring tRNA or corresponding coding nucleic acid (but a polynucleotide of the invention is other than a naturally

occurring tRNA or corresponding coding nucleic acid), where the tRNA recognizes a selector codon, e.g., a four base codon. Artificial polynucleotides that are, e.g., at least 80%, at least 90%, at least 95%, at least 98% or more identical to any of the above and/or a polynucleotide comprising a conservative variation of any the above, are also included in polynucleotides of the invention.

[0179] Vectors comprising a polynucleotide of the invention are also a feature of the invention. For example, a vector of the invention can include a plasmid, a cosmid, a phage, a virus, an expression vector, and/or the like. A cell comprising a vector of the invention is also a feature of the invention.

[0180] Methods of producing components of an O-tRNA/O—RS pair are also features of the invention. Components produced by these methods are also a feature of the invention. For example, methods of producing at least one tRNA that is orthogonal to a cell (O-tRNA) include generating a library of mutant tRNAs; mutating an anticodon loop of each member of the library of mutant tRNAs to allow recognition of a selector codon, thereby providing a library of potential O-tRNAs, and subjecting to negative selection a first population of cells of a first species, where the cells comprise a member of the library of potential O-tRNAs. The negative selection eliminates cells that comprise a member of the library of potential O-tRNAs that is aminoacylated by an aminoacyl-tRNA synthetase (RS) that is endogenous to the cell. This provides a pool of tRNAs that are orthogonal to the cell of the first species, thereby providing at least one O-tRNA. An O-tRNA produced by the methods of the invention is also provided.

[0181] In certain embodiments, the methods further comprise subjecting to positive selection a second population of cells of the first species, where the cells comprise a member of the pool of tRNAs that are orthogonal to the cell of the first species, a cognate aminoacyl-tRNA synthetase, and a positive selection marker. Using the positive selection, cells are selected or screened for those cells that comprise a member of the pool of tRNAs that is aminoacylated by the cognate aminoacyl-tRNA synthetase and that shows a desired response in the presence of the positive selection marker, thereby providing an O-tRNA. In certain embodiments, the second population of cells comprise cells that were not eliminated by the negative selection.

[0182] Methods for identifying an orthogonal-aminoacyl-tRNA synthetase that charges an O-tRNA with a GalNAc amino acid are also provided. For example, methods include subjecting a population of cells of a first species to a selection, where the cells each comprise: 1) a member of a plurality of aminoacyl-tRNA synthetases (RSs), (e.g., the plurality of RSs can include mutant RSs, RSs derived from a species other than a first species or both mutant RSs and RSs derived from a species other than a first species); 2) the orthogonal-tRNA (O-tRNA) (e.g., from one or more species); and 3) a polynucleotide that encodes a positive selection marker and comprises at least one selector codon.

[0183] Cells (e.g., a host cell) are selected or screened for those that show an enhancement in suppression efficiency compared to cells lacking or having a reduced amount of the member of the plurality of RSs. These selected/screened cells comprise an active RS that aminoacylates the O-tRNA. An orthogonal aminoacyl-tRNA synthetase identified by the method is also a feature of the invention.

[0184] Methods of producing a protein in a cell (e.g., in a eubacterial cell such as an *E. coli* cell or the like) having a

GalNAc- α -threonine at a specified position are also a feature of the invention. For example, a method includes growing, in an appropriate medium, a cell, where the cell comprises a nucleic acid that comprises at least one selector codon and encodes a protein, providing GalNAc- α -threonine, and incorporating GalNAc- α -threonine into the specified position in the protein during translation of the nucleic acid with the at least one selector codon, thereby producing the protein. The cell further comprises: an orthogonal-tRNA (O-tRNA) that functions in the cell and recognizes the selector codon; and, an orthogonal aminoacyl-tRNA synthetase (O—RS) that preferentially aminoacylates the O-tRNA with GalNAc- α -threonine. A protein produced by this method is also a feature of the invention.

[0185] The invention also provides compositions that include proteins, where the proteins comprise, e.g., GalNAc- α -threonine. In certain embodiments, the protein comprises an amino acid sequence that is at least 75% identical to that of a known protein, e.g., a therapeutic protein, a diagnostic protein, an industrial enzyme, or portion thereof. Optionally, the composition comprises a pharmaceutically acceptable carrier.

In Vivo Synthesis of Glycoproteins

[0186] One can use host cells and organisms that are adapted for the in vivo incorporation of the unnatural amino acid via orthogonal tRNA/RS pairs in the methods and translation systems of the present invention. To synthesize a glycoprotein in vivo, the polynucleotide encoding a polypeptide of interest (and into which one or more selector codons have been incorporated at the positions at which attachment of a saccharide moiety is desired) is introduced into the host cell, along with an orthogonal tRNA that recognizes the selector codon, and an orthogonal aminoacyl tRNA synthetase (O—RS) that catalyzes attachment of a glycosyl-containing unnatural amino acid to the orthogonal tRNA. The glycosyl-containing amino acid is typically exogenously added to the growth medium of the host cell, although optionally it too can be synthesized in vivo by engineering a biosynthetic pathway into the host cell. To produce the glycoprotein, the O—RS attaches the unnatural amino acid to the orthogonal tRNA, which, upon presentation of the appropriate selector codon by the translation machinery, then introduces the unnatural amino acid into the nascent glycopolyptide of interest.

[0187] Optionally, the host cells are genetically engineered (e.g., transformed, transduced or transfected) with one or more vectors that express one or more of the orthogonal tRNA, the orthogonal tRNA synthetase, and polynucleotide encoding the glycoprotein to be synthesized. These components can be on a single vector, or on a combination of vectors. Optionally, the vector can be in the form of a plasmid, a bacterium, a virus, a naked polynucleotide, or a conjugated polynucleotide.

[0188] Several well-known methods of introducing target nucleic acids into bacterial cells are available, any of which can be used in the invention. These include: fusion of the recipient cells with bacterial protoplasts containing the DNA, electroporation, projectile bombardment, and infection with viral vectors, etc. The engineered host cells can be cultured in conventional nutrient media modified as appropriate for such activities as, for example, screening steps, activating promoters or selecting transformants. These cells can optionally be cultured into transgenic organisms.

[0189] The coding regions for the orthogonal tRNA, the orthogonal tRNA synthetase, and the protein to be derivatized are operably linked to gene expression control elements that are functional in the desired host cell. Typical vectors contain transcription and translation terminators, transcription and translation initiation sequences, and promoters useful for regulation of the expression of the particular target nucleic acid. The vectors optionally comprise generic expression cassettes containing at least one independent terminator sequence, sequences permitting replication of the cassette in eukaryotes, or prokaryotes, or both (e.g., shuttle vectors) and selection markers for both prokaryotic and eukaryotic systems. Vectors are suitable for replication and/or integration in prokaryotes, eukaryotes, or preferably both. See Gilman & Smith, *Gene* 8:81 (1979); Roberts, et al., *Nature*, 328:731 (1987); Schneider, B., et al., *Protein Expr. Purif.* 6435:10 (1995); Berger and Kimmel, supra; Sambrook, supra, and Ausubel, supra. A catalogue of Bacteria and Bacteriophages useful for cloning is provided, e.g., by the ATCC, e.g., *The ATCC Catalogue of Bacteria and Bacteriophage* (1992) Gherna et al. (eds) published by the ATCC. Additional basic procedures for sequencing, cloning and other aspects of molecular biology and underlying theoretical considerations are also found in Watson et al. (1992) *Recombinant DNA Second Edition* Scientific American Books, NY. Proteins and Polypeptides of Interest.

[0190] For example, methods for producing glycoproteins include growing the cell in an appropriate medium, where the cell comprises a nucleic acid that comprises at least one selector codon and encodes a protein, providing an unnatural amino acid that includes a saccharide moiety, and incorporating the unnatural amino acid into the specified position in the protein during translation of the nucleic acid with the at least one selector codon, thereby producing the protein. Optionally, the nucleic acid comprises at least two selector codons, at least three selector codons, at least four selector codons, at least five selector codons, at least six selector codons, at least seven selector codons, at least eight selector codons, at least nine selector codons, or ten (or more) selector codons. The cell further comprises the O-tRNA that recognizes the selector codon and the O-RS that preferentially aminoacylates the O-tRNA with the glycosyl-containing unnatural amino acid. The general process is described in PCT International Publication WO 2002/085923, entitled "IN VIVO INCORPORATION OF UNNATURAL AMINO ACIDS" and International Publication WO 2004-03576, entitled "Site Specific Incorporation of Keto Amino Acids into Proteins," which are incorporated by reference.

[0191] Other useful references, e.g. for cell isolation and culture (e.g., for subsequent nucleic acid isolation) include Freshney (1994) *Culture of Animal Cells, a Manual of Basic Technique*, third edition, Wiley-Liss, New York and the references cited therein; Payne et al. (1992) *Plant Cell and Tissue Culture in Liquid Systems*, John Wiley & Sons, Inc. New York, N.Y.; Gamborg and Phillips (eds) (1995) *Plant Cell, Tissue and Organ Culture; Fundamental Methods* Springer Lab Manual, Springer-Verlag (Berlin Heidelberg New York) and Atlas and Parks (eds) *The Handbook of Microbiological Media* (1993) CRC Press, Boca Raton, Fla.

[0192] General texts which describe molecular biological techniques include Berger and Kimmel, *Guide to Molecular Cloning Techniques, Methods in Enzymology* volume 152 Academic Press, Inc., San Diego, Calif. (Berger); Sambrook et al., *Molecular Cloning—A Laboratory Manual* (3rd Ed.),

Vol. 1-3, Cold Spring Harbor Laboratory, Cold Spring Harbor, N.Y., 2001 ("Sambrook") and *Current Protocols in Molecular Biology* F. M. Ausubel et al., eds., *Current Protocols*, a joint venture between Greene Publishing Associates, Inc. and John Wiley & Sons, Inc., (supplemented through 2003) ("Ausubel"). These texts describe mutagenesis, the use of vectors, promoters and many other relevant topics related to, e.g., the generation of genes that include selector codons for production of proteins that include unnatural amino acids, orthogonal tRNAs, orthogonal synthetases, and pairs thereof.

Glycosyltransferases

[0193] The invention further provides methods in which the unnatural amino acid having saccharide moiety is further glycosylated. These glycosylation steps are preferably carried out enzymatically using, for example, a glycosyltransferase, glycosidase, or other enzyme known to those of skill in the art. In some embodiments, a plurality of enzymatic steps are carried out in a single reaction mixture that contains two or more different glycosyltransferases. For example, one can conduct a galactosylating and a sialylating step simultaneously by including both sialyltransferase and galactosyltransferase in the reaction mixture.

[0194] For enzymatic saccharide syntheses that involve glycosyltransferase reactions, the recombinant cells of the invention optionally contain at least one heterologous gene that encodes a glycosyltransferase. Many glycosyltransferases are known, as are their polynucleotide sequences. See, e.g., "The WWW Guide To Cloned Glycosyltransferases," (available on the World Wide Web). Glycosyltransferase amino acid sequences and nucleotide sequences encoding glycosyltransferases from which the amino acid sequences can be deduced are also found in various publicly available databases, including GenBank, Swiss-Prot, EMBL, and others.

[0195] Glycosyltransferases that can be employed in the cells of the invention include, but are not limited to, galactosyltransferases, fucosyltransferases, glucosyltransferases, N-acetylgalactosaminyltransferases, N-acetylglucosaminyltransferases, glucuronyltransferases, sialyltransferases, mannosyltransferases, glucuronic acid transferases, galacturonic acid transferases, oligosaccharyltransferases, and the like. Suitable glycosyltransferases include those obtained from eukaryotes, as well as from prokaryotes.

[0196] The glycosylation reactions include, in addition to the appropriate glycosyltransferase and acceptor, an activated nucleotide sugar that acts as a sugar donor for the glycosyltransferase. The reactions can also include other ingredients that facilitate glycosyltransferase activity. These ingredients can include a divalent cation (e.g., Mg^{+2} or Mn^{+2}), materials necessary for ATP regeneration, phosphate ions, and organic solvents. The concentrations or amounts of the various reactants used in the processes depend upon numerous factors including reaction conditions such as temperature and pH value, and the choice and amount of acceptor saccharides to be glycosylated. The reaction medium may also comprise solubilizing detergents (e.g., Triton or SDS) and organic solvents such as methanol or ethanol, if necessary.

Nucleic Acid and Polypeptide Sequences and Variants

[0197] As described herein, the invention provides for polynucleotide sequences encoding, e.g., O-tRNAs and

O—RSs, and polypeptide amino acid sequences, e.g., O—RSs, as well as compositions, methods, translation systems and kits comprising said sequences. Examples of said sequences, e.g., O-tRNA and O—RS amino acid and nucleotide sequences are disclosed herein (see Table 3, e.g., SEQ ID NOs: 1-17). However, one of skill in the art will appreciate that the invention is not limited to those sequences disclosed herein, e.g., in the EXAMPLES and sequence listing. One of skill will appreciate that the invention also provides e.g., many additional related sequences with the functions described herein, e.g., encoding an O-tRNA or an O—RS with the functions described herein, e.g., encoding an O—RS that charges an O-tRNA with a glycosyl-containing unnatural amino acid. The construction and analysis of O—RS species that are able to aminoacylate the O-tRNA with GalNAc- α -threonine is described in the EXAMPLES. These EXAMPLES provide four O—RS species that were isolated. The present specification further provides sufficient guidance to design additional O—RS species, which are within the scope of the present invention, e.g., conservative variants of the isolated O—RS species.

[0198] The present invention provides polypeptides (e.g., O—RSs) and polynucleotides (e.g., O-tRNA, polynucleotides that encode O—RSs or portions thereof, oligonucleotides used to isolate aminoacyl-tRNA synthetase clones, etc.). A polypeptide of the invention also includes an artificial polypeptide, e.g., (a) a polypeptide that comprises an amino acid sequence as shown in any one of SEQ ID NO.: 1-4 and 11-13; (b) a polypeptide that comprises an amino acid sequence encoded by a polynucleotide sequence as shown in any one of SEQ ID NO.: 6-9 and 14-16; (c) a polypeptide that is specifically immunoreactive with an antibody specific for a polypeptide of (a), or (b); and, (d) an amino acid sequence comprising a conservative variation of (a), (b), or (c). Antibodies and antisera that are specifically immunoreactive with an artificial polypeptide of the invention are also provided. In one embodiment, a composition includes a polypeptide of the invention and an excipient (e.g., buffer, water, pharmaceutically acceptable excipient, etc.).

[0199] Polynucleotides of the invention include those with one or more selector codon that encode proteins or polypeptides of interest. A polynucleotide of the invention also includes a polynucleotide of any one of SEQ ID NOS.: 6-9, 14-16, or a conservative variation thereof, as well as other polynucleotides that encodes an amino acid sequence comprising SEQ ID NO.: 1-4 or 11-13 (or a conservative variation of these amino acid sequences). Similarly, an artificial nucleic acid that hybridizes to a polynucleotide indicated above under highly stringent conditions over substantially the entire length of the nucleic acid (and is other than a naturally polynucleotide) is a polynucleotide of the invention. An artificial polynucleotide is a polynucleotide that is man made and is not naturally occurring.

[0200] The invention provides polypeptides (O-RSs) and polynucleotides, e.g., O-tRNA, polynucleotides that encode O—RSs or portions thereof, oligonucleotides used to isolate aminoacyl-tRNA synthetase clones, etc. Polynucleotides of the invention include those that encode proteins or polypeptides of interest of the invention with one or more selector codon. In addition, polynucleotides of the invention include, e.g., a polynucleotide comprising a nucleotide sequence as set forth in SEQ ID NO: 6, 7, 8 or 9; a polynucleotide that is complementary to or that encodes a polynucleotide sequence thereof. A polynucleotide of the invention also includes any

polynucleotide that encodes an amino acid sequence comprising SEQ ID NO: 1, 2, 3 or 4. A polynucleotide of the invention also includes a polynucleotide that encodes a polypeptide of the invention. Similarly, an artificial nucleic acid that hybridizes to a polynucleotide indicated above under highly stringent conditions over substantially the entire length of the nucleic acid (and is other than a naturally occurring polynucleotide) is a polynucleotide of the invention. In one embodiment, a composition includes a polypeptide of the invention and an excipient (e.g., buffer, water, pharmaceutically acceptable excipient, etc.). The invention also provides an antibody or antisera specifically immunoreactive with a polypeptide of the invention. An artificial polynucleotide is a polynucleotide that is man made and is not naturally occurring.

[0201] A polynucleotide of the invention also includes an artificial polynucleotide that is, e.g., at least 75%, at least 80%, at least 90%, at least 95%, at least 98% or more identical to that of a naturally occurring tRNA, (but is other than a naturally occurring tRNA). A polynucleotide also includes an artificial polynucleotide that is, e.g., at least 75%, at least 80%, at least 90%, at least 95%, at least 98% or more identical (but not 100% identical) to that of a naturally occurring tRNA.

[0202] In certain embodiments, a vector (e.g., a plasmid, a cosmid, a phage, a virus, etc.) comprises a polynucleotide of the invention. In one embodiment, the vector is an expression vector. In another embodiment, the expression vector includes a promoter operably linked to one or more of the polynucleotides of the invention. In another embodiment, a cell comprises a vector that includes a polynucleotide of the invention.

[0203] One of skill will also appreciate that many variants of the disclosed sequences are included in the invention. For example, conservative variations of the disclosed sequences that yield a functionally identical sequence are included in the invention. Variants of the nucleic acid polynucleotide sequences, wherein the variants hybridize to at least one disclosed sequence, are considered to be included in the invention. Unique subsequences of the sequences disclosed herein, as determined by, e.g., standard sequence comparison techniques, are also included in the invention.

[0204] Conservative Variations

[0205] Owing to the degeneracy of the genetic code, “silent substitutions” (i.e., substitutions in a nucleic acid sequence which do not result in an alteration in an encoded polypeptide) are an implied feature of every nucleic acid sequence that encodes an amino acid sequence. Similarly, “conservative amino acid substitutions,” where one or more amino acids in an amino acid sequence are substituted with different amino acids with similar chemical properties, are also readily identified as being highly similar to a disclosed construct. Such conservative variations of each disclosed sequence are a feature of the present invention.

[0206] “Conservative variations” of a particular nucleic acid sequence refers to those nucleic acids which encode identical or essentially identical amino acid sequences, or, where the nucleic acid does not encode an amino acid sequence, to essentially identical sequences. One of skill will recognize that individual substitutions, deletions or additions which alter, add or delete a single amino acid or a small percentage of amino acids (typically less than 5%, more typically less than 4%, 2% or 1%) in an encoded sequence are “conservatively modified variations” where the alterations

result in the deletion of an amino acid, addition of an amino acid, or substitution of an amino acid with a chemically similar amino acid. Thus, “conservative variations” of a listed polypeptide sequence of the present invention include substitutions of a small percentage, typically less than 5%, more typically less than 2% or 1%, of the amino acids of the polypeptide sequence, with an amino acid of the same conservative substitution group. Finally, the addition of sequences which do not alter the encoded activity of a nucleic acid molecule, such as the addition of a non-functional sequence, is a conservative variation of the basic nucleic acid.

[0207] Conservative substitution tables providing functionally similar amino acids are well known in the art, where one amino acid residue is substituted for another amino acid residue having similar chemical properties (e.g., aromatic side chains or positively charged side chains), and therefore does not substantially change the functional properties of the polypeptide molecule. The following sets forth example groups that contain natural amino acids of like chemical properties, where substitutions within a group is a “conservative substitution”.

TABLE 3

Nonpolar and/or Aliphatic Side Chains	Polar, Uncharged Side Chains	Aromatic Side Chains	Positively Charged Side Chains	Negatively Charged Side Chains
Glycine	Serine	Phenylalanine	Lysine	Aspartate
Alanine	Threonine	Tyrosine	Arginine	Glutamate
Valine	Cysteine	Tryptophan	Histidine	
Leucine	Methionine			
Isoleucine	Asparagine			
Proline	Glutamine			

[0208] Nucleic Acid Hybridization

[0209] Comparative hybridization can be used to identify nucleic acids of the invention, such as SEQ ID NO.: 6-9 and 14-16, including conservative variations of nucleic acids of the invention, and this comparative hybridization method is a preferred method of distinguishing nucleic acids of the invention. In addition, target nucleic acids which hybridize to a nucleic acid represented by, e.g., SEQ ID NOs: 6-9 and 14-16 under high, ultra-high and ultra-ultra high stringency conditions are a feature of the invention. Examples of such nucleic acids include those with one or a few silent or conservative nucleic acid substitutions as compared to a given nucleic acid sequence.

[0210] A test nucleic acid is said to specifically hybridize to a probe nucleic acid when it hybridizes at least 50% as well to the probe as to the perfectly matched complementary target, i.e., with a signal to noise ratio at least half as high as hybridization of the probe to the target under conditions in which the perfectly matched probe binds to the perfectly matched complementary target with a signal to noise ratio that is at least about 5×-10× as high as that observed for hybridization to any of the unmatched target nucleic acids.

[0211] Nucleic acids “hybridize” when they associate, typically in solution. Nucleic acids hybridize due to a variety of well characterized physico-chemical forces, such as hydrogen bonding, solvent exclusion, base stacking and the like. An extensive guide to the hybridization of nucleic acids is found in Tijssen (1993) *Laboratory Techniques in, Biochemistry and Molecular Biology—Hybridization with Nucleic Acid Probes* part I chapter 2, “Overview of principles of hybrid-

ization and the strategy of nucleic acid probe assays,” (Elsevier, N.Y.), as well as in *Current Protocols in Molecular Biology*, Ausubel et al., eds., *Current Protocols*, a joint venture between Greene Publishing Associates, Inc. and John Wiley & Sons, Inc., (supplemented through 2004) (“Ausubel”); Hames and Higgins (1995) *Gene Probes 1* IRL Press at Oxford University Press, Oxford, England, (Hames and Higgins 1) and Hames and Higgins (1995) *Gene Probes 2* IRL Press at Oxford University Press, Oxford, England (Hames and Higgins 2) provide details on the synthesis, labeling, detection and quantification of DNA and RNA, including oligonucleotides.

[0212] An example of stringent hybridization conditions for hybridization of complementary nucleic acids which have more than 100 complementary residues on a filter in a Southern or northern blot is 50% formalin with 1 mg of heparin at 42° C., with the hybridization being carried out overnight. An example of stringent wash conditions is a 0.2×SSC wash at 65° C. for 15 minutes (see, Sambrook, supra for a description of SSC buffer). Often the high stringency wash is preceded by a low stringency wash to remove background probe signal. An example low stringency wash is 2×SSC at 40° C. for 15 minutes. In general, a signal to noise ratio of 5× (or higher) than that observed for an unrelated probe in the particular hybridization assay indicates detection of a specific hybridization.

[0213] “Stringent hybridization wash conditions” in the context of nucleic acid hybridization experiments such as Southern and northern hybridizations are sequence dependent, and are different under different environmental parameters. An extensive guide to the hybridization of nucleic acids is found in Tijssen (1993), supra. and in Hames and Higgins, 1 and 2. Stringent hybridization and wash conditions can easily be determined empirically for any test nucleic acid. For example, in determining stringent hybridization and wash conditions, the hybridization and wash conditions are gradually increased (e.g., by increasing temperature, decreasing salt concentration, increasing detergent concentration and/or increasing the concentration of organic solvents such as formalin in the hybridization or wash), until a selected set of criteria are met. For example, in highly stringent hybridization and wash conditions, the hybridization and wash conditions are gradually increased until a probe binds to a perfectly matched complementary target with a signal to noise ratio that is at least 5× as high as that observed for hybridization of the probe to an unmatched target.

[0214] “Very stringent” conditions are selected to be equal to the thermal melting point (T_m) for a particular probe. The T_m is the temperature (under defined ionic strength and pH) at which 50% of the test sequence hybridizes to a perfectly matched probe. For the purposes of the present invention, generally, “highly stringent” hybridization and wash conditions are selected to be about 5° C. lower than the T_m for the specific sequence at a defined ionic strength and pH.

[0215] “Ultra high-stringency” hybridization and wash conditions are those in which the stringency of hybridization and wash conditions are increased until the signal to noise ratio for binding of the probe to the perfectly matched complementary target nucleic acid is at least 10× as high as that observed for hybridization to any of the unmatched target nucleic acids. A target nucleic acid which hybridizes to a probe under such conditions, with a signal to noise ratio of at

least 1/2 that of the perfectly matched complementary target nucleic acid is said to bind to the probe under ultra-high stringency conditions.

[0216] Similarly, even higher levels of stringency can be determined by gradually increasing the hybridization and/or wash conditions of the relevant hybridization assay. For example, those in which the stringency of hybridization and wash conditions are increased until the signal to noise ratio for binding of the probe to the perfectly matched complementary target nucleic acid is at least 10×, 20×, 50×, 100×, or 500× or more as high as that observed for hybridization to any of the unmatched target nucleic acids. A target nucleic acid which hybridizes to a probe under such conditions, with a signal to noise ratio of at least 1/2 that of the perfectly matched complementary target nucleic acid is said to bind to the probe under ultra-ultra-high stringency conditions.

[0217] Nucleic acids which do not hybridize to each other under stringent conditions are still substantially identical if the polypeptides which they encode are substantially identical. This occurs, e.g., when a copy of a nucleic acid is created using the maximum codon degeneracy permitted by the genetic code.

[0218] Unique Subsequences

[0219] In one aspect, the invention provides a nucleic acid that comprises a unique subsequence in a nucleic acid selected from the sequences of O-tRNAs and O-RSs disclosed herein. The unique subsequence is unique as compared to a nucleic acid corresponding to any known O-tRNA or O-RS nucleic acid sequence. Alignment can be performed using, e.g., BLAST set to default parameters. Any unique subsequence is useful, e.g., as a probe to identify the nucleic acids of the invention.

[0220] Similarly, the invention includes a polypeptide which comprises a unique subsequence in a polypeptide selected from the sequences of O-RSs disclosed herein. Here, the unique subsequence is unique as compared to a polypeptide corresponding to any of known polypeptide sequence.

[0221] The invention also provides for target nucleic acids which hybridizes under stringent conditions to a unique coding oligonucleotide which encodes a unique subsequence in a polypeptide selected from the sequences of O-RSs wherein the unique subsequence is unique as compared to a polypeptide corresponding to any of the control polypeptides (e.g., parental sequences from which synthetases of the invention were derived, e.g., by mutation). Unique sequences are determined as noted above.

[0222] Sequence Comparison Identity, and Homology

[0223] The terms “identical” or “percent identity,” in the context of two or more nucleic acid or polypeptide sequences, refer to two or more sequences or subsequences that are the same or have a specified percentage of amino acid residues or nucleotides that are the same, when compared and aligned for maximum correspondence, as measured using one of the sequence comparison algorithms described below (or other algorithms available to persons of skill) or by visual inspection.

[0224] The phrase “substantially identical,” in the context of two nucleic acids or polypeptides (e.g., DNAs encoding an O-tRNA or O-RS, or the amino acid sequence of an O-RS) refers to two or more sequences or subsequences that have at least about 60%, about 80%, about 90-95%, about 98%, about 99% or more nucleotide or amino acid residue identity, when compared and aligned for maximum correspondence, as mea-

sured using a sequence comparison algorithm or by visual inspection. Such “substantially identical” sequences are typically considered to be “homologous,” without reference to actual ancestry. Preferably, the “substantial identity” exists over a region of the sequences that is at least about 50 residues in length, more preferably over a region of at least about 100 residues, and most preferably, the sequences are substantially identical over at least about 150 residues, or over the full length of the two sequences to be compared.

[0225] Proteins and/or protein sequences are “homologous” when they are derived, naturally or artificially, from a common ancestral protein or protein sequence. Similarly, nucleic acids and/or nucleic acid sequences are homologous when they are derived, naturally or artificially, from a common ancestral nucleic acid or nucleic acid sequence. For example, any naturally occurring nucleic acid can be modified by any available mutagenesis method to include one or more selector codon. When expressed, this mutagenized nucleic acid encodes a polypeptide comprising one or more unnatural amino acid, e.g. a GalNAc amino acid. The mutation process can, of course, additionally alter one or more standard codon, thereby changing one or more standard amino acid in the resulting mutant protein as well. Homology is generally inferred from sequence similarity between two or more nucleic acids or proteins (or sequences thereof). The precise percentage of similarity between sequences that is useful in establishing homology varies with the nucleic acid and protein at issue, but as little as 25% sequence similarity is routinely used to establish homology. Higher levels of sequence similarity, e.g., 30%, 40%, 50%, 60%, 70%, 80%, 90%, 95%, or 99% or more, can also be used to establish homology. Methods for determining sequence similarity percentages (e.g., BLASTP and BLASTN using default parameters) are described herein and are generally available.

[0226] For sequence comparison and homology determination, typically one sequence acts as a reference sequence to which test sequences are compared. When using a sequence comparison algorithm, test and reference sequences are input into a computer, subsequence coordinates are designated, if necessary, and sequence algorithm program parameters are designated. The sequence comparison algorithm then calculates the percent sequence identity for the test sequence(s) relative to the reference sequence, based on the designated program parameters.

[0227] Optimal alignment of sequences for comparison can be conducted, e.g., by the local homology algorithm of Smith & Waterman, *Adv. Appl. Math.* 2:482 (1981), by the homology alignment algorithm of Needleman & Wunsch, *J. Mol. Biol.* 48:443 (1970), by the search for similarity method of Pearson & Lipman, *Proc. Nat'l. Acad. Sci. USA* 85:2444 (1988), by computerized implementations of these algorithms (GAP, BESTFIT, FASTA, and TFASTA in the Wisconsin Genetics Software Package, Genetics Computer Group, 575 Science Dr., Madison, Wis.), or by visual inspection (see generally *Current Protocols in Molecular Biology*, Ausubel et al., eds., *Current Protocols*, a joint venture between Greene Publishing Associates, Inc. and John Wiley & Sons, Inc., supplemented through 2004).

[0228] One example of an algorithm that is suitable for determining percent sequence identity and sequence similarity is the BLAST algorithm, which is described in Altschul et al., *J. Mol. Biol.* 215:403-410 (1990). Software for performing BLAST analyses is publicly available through the National Center for Biotechnology Information website. This

algorithm involves first identifying high scoring sequence pairs (HSPs) by identifying short words of length W in the query sequence, which either match or satisfy some positive-valued threshold score T when aligned with a word of the same length in a database sequence. T is referred to as the neighborhood word score threshold (Altschul et al., supra). These initial neighborhood word hits act as seeds for initiating searches to find longer HSPs containing them. The word hits are then extended in both directions along each sequence for as far as the cumulative alignment score can be increased. Cumulative scores are calculated using, for nucleotide sequences, the parameters M (reward score for a pair of matching residues; always >0) and N (penalty score for mismatching residues; always <0). For amino acid sequences, a scoring matrix is used to calculate the cumulative score. Extension of the word hits in each direction are halted when: the cumulative alignment score falls off by the quantity X from its maximum achieved value; the cumulative score goes to zero or below, due to the accumulation of one or more negative-scoring residue alignments; or the end of either sequence is reached. The BLAST algorithm parameters W , T , and X determine the sensitivity and speed of the alignment. The BLASTN program (for nucleotide sequences) uses as defaults a wordlength (W) of 11, an expectation (E) of 10, a cutoff of 100, $M=5$, $N=-4$, and a comparison of both strands. For amino acid sequences, the BLASTP program uses as defaults a wordlength (W) of 3, an expectation (E) of 10, and the BLOSUM62 scoring matrix (see Henikoff & Henikoff (1989) *Proc. Natl. Acad. Sci. USA* 89:10915).

[0229] In addition to calculating percent sequence identity, the BLAST algorithm also performs a statistical analysis of the similarity between two sequences (see, e.g., Karlin & Altschul, *Proc. Nat'l. Acad. Sci. USA* 90:5873-5787 (1993)). One measure of similarity provided by the BLAST algorithm is the smallest sum probability ($P(N)$), which provides an indication of the probability by which a match between two nucleotide or amino acid sequences would occur by chance. For example, a nucleic acid is considered similar to a reference sequence if the smallest sum probability in a comparison of the test nucleic acid to the reference nucleic acid is less than about 0.1, more preferably less than about 0.01, and most preferably less than about 0.001.

[0230] Mutagenesis and Other Molecular Biology Techniques

[0231] Polynucleotide and polypeptides of the invention and used in the invention can be manipulated using molecular biological techniques. General texts which describe molecular biological techniques include Berger and Kimmel, *Guide to Molecular Cloning Techniques, Methods in Enzymology* volume 152 Academic Press, Inc., San Diego, Calif. (Berger); Sambrook et al., *Molecular Cloning—A Laboratory Manual* (3rd Ed.), Vol. 1-3, Cold Spring Harbor Laboratory, Cold Spring Harbor, N.Y., 2001 (“Sambrook”) and *Current Protocols in Molecular Biology*, F. M. Ausubel et al., eds., *Current Protocols*, a joint venture between Greene Publishing Associates, Inc. and John Wiley & Sons, Inc., (supplemented through 2004) (“Ausubel”). These texts describe mutagenesis, the use of vectors, promoters and many other relevant topics related to, e.g., the generation of genes that include selector codons for production of proteins that include GalNAc amino acids (e.g., GalNAc- α -threonine), orthogonal tRNAs, orthogonal synthetases, and pairs thereof.

[0232] Various types of mutagenesis are used in the invention, e.g., to mutate tRNA molecules, to produce libraries of

tRNAs, to produce libraries of synthetases, to insert selector codons that encode a GalNAc amino acid in a protein or polypeptide of interest. They include but are not limited to site-directed, random point mutagenesis, homologous recombination, DNA shuffling or other recursive mutagenesis methods, chimeric construction, mutagenesis using uracil containing templates, oligonucleotide-directed mutagenesis, phosphorothioate-modified DNA mutagenesis, mutagenesis using gapped duplex DNA or the like, or any combination thereof. Additional suitable methods include point mismatch repair, mutagenesis using repair-deficient host strains, restriction-selection and restriction-purification, deletion mutagenesis, mutagenesis by total gene synthesis, double-strand break repair, and the like. Mutagenesis, e.g., involving chimeric constructs, is also included in the present invention. In one embodiment, mutagenesis can be guided by known information of the naturally occurring molecule or altered or mutated naturally occurring molecule, e.g., sequence, sequence comparisons, physical properties, crystal structure or the like.

[0233] Host cells are genetically engineered (e.g., transformed, transduced or transfected) with the polynucleotides of the invention or constructs which include a polynucleotide of the invention, e.g., a vector of the invention, which can be, for example, a cloning vector or an expression vector. For example, the coding regions for the orthogonal tRNA, the orthogonal tRNA synthetase, and the protein to be derivatized are operably linked to gene expression control elements that are functional in the desired host cell. Typical vectors contain transcription and translation terminators, transcription and translation initiation sequences, and promoters useful for regulation of the expression of the particular target nucleic acid. The vectors optionally comprise generic expression cassettes containing at least one independent terminator sequence, sequences permitting replication of the cassette in eukaryotes, or prokaryotes, or both (e.g., shuttle vectors) and selection markers for both prokaryotic and eukaryotic systems. Vectors are suitable for replication and/or integration in prokaryotes, eukaryotes, or preferably both. See Giliman & Smith, *Gene* 8:81 (1979); Roberts, et al., *Nature*, 328:731 (1987); Schneider, B., et al., *Protein Expr. Purif.* 6435:10 (1995); Ausubel, Sambrook, Berger (all supra). The vector can be, for example, in the form of a plasmid, a bacterium, a virus, a naked polynucleotide, or a conjugated polynucleotide. The vectors are introduced into cells and/or microorganisms by standard methods including electroporation (From et al., *Proc. Natl. Acad. Sci. USA* 82, 5824 (1985), infection by viral vectors, high velocity ballistic penetration by small particles with the nucleic acid either within the matrix of small beads or particles, or on the surface (Klein et al., *Nature* 327, 70-73 (1987)), and/or the like.

[0234] A catalogue of Bacteria and Bacteriophages useful for cloning is provided, e.g., by the ATCC, e.g., *The ATCC Catalogue of Bacteria and Bacteriophage* (1996) Gherna et al. (eds) published by the ATCC. Additional basic procedures for sequencing, cloning and other aspects of molecular biology and underlying theoretical considerations are also found in Sambrook (supra), Ausubel (supra), and in Watson et al. (1992) *Recombinant DNA Second Edition* Scientific American Books, NY. In addition, essentially any nucleic acid (and virtually any labeled nucleic acid, whether standard or non-standard) can be custom or standard ordered from any of a variety of commercial sources, such as the Midland Certified Reagent Company (Midland, Tex. mrc.com), The Great

American Gene Company (Ramona, Calif. available on the World Wide Web at genco.com), ExpressGen Inc. (Chicago, Ill. available on the World Wide Web at expressgen.com), Operon Technologies Inc. (Alameda, Calif.) and many others.

[0235] The engineered host cells can be cultured in conventional nutrient media modified as appropriate for such activities as, for example, screening steps, activating promoters or selecting transformants. These cells can optionally be cultured into transgenic organisms. Other useful references, e.g. for cell isolation and culture (e.g., for subsequent nucleic acid isolation) include Freshney (1994) *Culture of Animal Cells, a Manual of Basic Technique*, third edition, Wiley-Liss, New York and the references cited therein; Payne et al. (1992) *Plant Cell and Tissue Culture in Liquid Systems* John Wiley & Sons, Inc. New York, N.Y.; Gamborg and Phillips (eds) (1995) *Plant Cell, Tissue and Organ Culture; Fundamental Methods* Springer Lab Manual, Springer-Verlag (Berlin Heidelberg New York) and Atlas and Parks (eds) *The Handbook of Microbiological Media* (1993) CRC Press, Boca Raton, Fla.

Proteins and Polypeptides of Interest

[0236] Proteins or polypeptides of interest (e.g., with at least one GalNAc amino acid such as GalNAc- α -threonine) are a feature of the invention. The invention includes polypeptides or proteins with at least one GalNAc amino acid produced using the compositions and methods of the invention. An excipient (e.g., a pharmaceutically acceptable excipient) can also be present with the protein. Optionally, a protein of the invention can include a post-translational modification (for example, a subsequent modification of the GalNAc moiety, such as the attachment of additional saccharide moieties) at a single amino acid position or multiple positions, or the protein can have a plurality of different types of modifications.

[0237] Methods of producing a protein in a cell with a GalNAc amino acid at a specified position are also a feature of the invention. For example, a method includes growing, in an appropriate medium, the cell, where the cell comprises a nucleic acid that comprises at least one selector codon and encodes a protein; and, providing the GalNAc amino acid; where the cell further comprises: an orthogonal-tRNA (O-tRNA) that functions in the cell and recognizes the selector codon; and, an orthogonal aminoacyl-tRNA synthetase (O-RS) that preferentially aminoacylates the O-tRNA with the GalNAc amino acid. A protein produced by this method is also a feature of the invention.

[0238] In certain embodiments, the O-RS comprises a bias for the aminoacylation of the cognate O-tRNA over any endogenous tRNA in an expression system. The relative ratio between O-tRNA and endogenous tRNA that is charged by the O-RS, when the O-tRNA and O-RS are present at equal molar concentrations, is greater than 1:1, preferably at least about 2:1, more preferably 5:1, still more preferably 10:1, yet more preferably 20:1, still more preferably 50:1, yet more preferably 75:1, still more preferably 95:1, 98:1, 99:1, 100:1, 500:1, 1,000:1, 5,000:1 or higher.

[0239] The invention also provides compositions that include proteins, where the proteins comprise an GalNAc amino acid. In certain embodiments, the protein comprises an amino acid sequence that is at least 75% identical to that of a therapeutic protein, a diagnostic protein, an industrial enzyme, or portion thereof.

[0240] The compositions of the invention and compositions made by the methods of the invention optionally are in a cell. The O-tRNA/O-RS pairs or individual components of the invention can then be used in a host system's translation machinery, which results in a GalNAc amino acid being incorporated into a protein. International Publication Numbers WO 2004/094593, filed Apr. 16, 2004, entitled "EXPANDING THE EUKARYOTIC GENETIC CODE," and WO 2002/085923, entitled "IN VIVO INCORPORATION OF UNNATURAL AMINO ACIDS," describe this process, and are incorporated herein by reference. For example, when an O-tRNA/O-RS pair is introduced into a host, e.g., an *Escherichia coli* cell, the pair leads to the in vivo incorporation of an GalNAc amino acid such as GalNAc- α -threonine into a protein in response to a selector codon. The GalNAc- α -threonine that is added to the system is a synthetic amino acid, such as a threonine derivative, which can be exogenously added to the growth medium. Optionally, the compositions of the present invention can be in an in vitro translation system, or in an in vivo system(s).

[0241] A translation system of the invention, for example a translation system comprising a host cell, provides the ability to synthesize proteins that comprise unnatural amino acids in large useful quantities. In one aspect, the composition optionally includes, e.g., at least 10 micrograms, at least 50 micrograms, at least 75 micrograms, at least 100 micrograms, at least 200 micrograms, at least 250 micrograms, at least 500 micrograms, at least 1 milligram, at least 10 milligrams or more of the protein that comprises a GalNAc amino acid, or an amount that can be achieved with in vivo protein production methods (details on recombinant protein production and purification are provided herein). In another aspect, the protein is optionally present in the composition at a concentration of, e.g., at least 10 micrograms of protein per liter, at least 50 micrograms of protein per liter, at least 75 micrograms of protein per liter, at least 100 micrograms of protein per liter, at least 200 micrograms of protein per liter, at least 250 micrograms of protein per liter, at least 500 micrograms of protein per liter, at least 1 milligram of protein per liter, or at least 10 milligrams of protein per liter or more, in, e.g., a cell lysate, a buffer, a pharmaceutical buffer, or other liquid suspension (e.g., in a volume of, e.g., anywhere from about 1 nL to about 100 L). The production of large quantities (e.g., greater than that typically possible with other methods, e.g., in vitro translation) of a protein in a cell including at least one GalNAc amino acid is a feature of the invention.

[0242] The incorporation of a GalNAc amino acid can be done to, e.g., tailor changes in protein structure and/or function, e.g., to change size, acidity, nucleophilicity, hydrogen bonding, hydrophobicity, accessibility of protease target sites, target to a moiety (e.g., for a protein array), etc. Proteins that include a GalNAc amino acid can have enhanced or even entirely new catalytic or physical properties. For example, the following properties are optionally modified by inclusion of a GalNAc amino acid into a protein: toxicity, biodistribution, structural properties, spectroscopic properties, chemical and/or photochemical properties, catalytic ability, half-life (e.g., serum half-life), ability to react with other molecules, e.g., covalently or noncovalently, and the like. The compositions including proteins that include at least one GalNAc amino acid are useful for, e.g., novel therapeutics, diagnostics, catalytic enzymes, industrial enzymes, binding proteins (e.g., antibodies), and e.g., the study of protein structure and func-

tion. See, e.g., Dougherty, (2000) Unnatural Amino Acids as Probes of Protein Structure and Function, *Current Opinion in Chemical Biology*, 4:645-652.

[0243] In one aspect of the invention, a composition includes at least one protein with at least one, e.g., at least two, at least three, at least four, at least five, at least six, at least seven, at least eight, at least nine, or at least ten or more unnatural amino acids, e.g., GalNAc amino acids and/or other unnatural amino acids. The unnatural amino acids can be the same or different, e.g., there can be 1, 2, 3, 4, 5, 6, 7, 8, 9, or 10 or more different sites in the protein that comprise 1, 2, 3, 4, 5, 6, 7, 8, 9, or 10 or more different unnatural amino acids. In another aspect, a composition includes a protein with at least one, but fewer than all, of a particular amino acid present in the protein is substituted with the GalNAc amino acid. For a given protein with more than one unnatural amino acids, the unnatural amino acids can be identical or different (e.g., the protein can include two or more different types of unnatural amino acids, or can include two of the same unnatural amino acid). For a given protein with more than two unnatural amino acids, the unnatural amino acids can be the same, different or a combination of a multiple unnatural amino acid of the same kind with at least one different unnatural amino acid.

[0244] Essentially any protein (or portion thereof) that includes a galactosamine- or glucosamine-containing unnatural amino acid (and any corresponding coding nucleic acid, e.g., which includes one or more selector codons) can be produced using the compositions and methods herein. No attempt is made to identify the hundreds of thousands of known proteins, any of which can be modified to include one or more unnatural amino acid, e.g., by tailoring any available mutation methods to include one or more appropriate selector codon in a relevant translation system. Common sequence repositories for known proteins include GenBank EMBL, DDBJ and the NCBI. Other repositories can easily be identified by searching the internet.

[0245] Typically, the proteins are, e.g., at least 60%, at least 70%, at least 75%, at least 80%, at least 90%, at least 95%, or at least 99% or more identical to any available protein (e.g., a therapeutic protein, a diagnostic protein, an industrial enzyme, or portion thereof, and the like), and they comprise one or more unnatural amino acid. Examples of therapeutic, diagnostic, and other proteins that can be modified to comprise one or more GalNAc amino acid can be found, but not limited to, those in International Publications WO 2004/094593, filed Apr. 16, 2004, entitled "Expanding the Eukaryotic Genetic Code;" and, WO 2002/085923, entitled "IN VIVO INCORPORATION OF UNNATURAL AMINO ACIDS." Examples of therapeutic, diagnostic, and other proteins that can be modified to comprise one or more GalNAc amino acids include, but are not limited to, e.g., Alpha-1 antitrypsin, Angiostatin, Antihemolytic factor, antibodies (further details on antibodies are found below), Apolipoprotein, Apoprotein, Atrial natriuretic factor, Atrial natriuretic polypeptide, Atrial peptides, C—X—C chemokines (e.g., T39765, NAP-2, ENA-78, Gro-a, Gro-b, Gro-c, IP-10, GCP-2, NAP-4, SDF-1, PF4, MIG), Calcitonin, CC chemokines (e.g., Monocyte chemoattractant protein-1, Monocyte chemoattractant protein-2, Monocyte chemoattractant protein-3, Monocyte inflammatory protein-1 alpha, Monocyte inflammatory protein-1 beta, RANTES, 1309, R83915, R91733, HCC1, T58847, D31065, T64262), CD40 ligand, C-kit Ligand, Collagen, Colony stimulating factor (CSF), Complement factor 5a, Complement inhibitor, Complement

receptor 1, cytokines, (e.g., epithelial Neutrophil Activating Peptide-78, GRO α /MGSA, GRO β , GRO γ , MIP-1 α , MIP-1 δ , MCP-1), Epidermal Growth Factor (EGF), Erythropoietin ("EPO"), Exfoliating toxins A and B, Factor IX, Factor VII, Factor VIII, Factor X, Fibroblast Growth Factor (FGF), Fibrinogen, Fibronectin, G-CSF, GM-CSF, Glucocerebrosidase, Gonadotropin, growth factors, Hedgehog proteins (e.g., Sonic, Indian, Desert), Hemoglobin, Hepatocyte Growth Factor (HGF), Hirudin, Human serum albumin, Insulin, Insulin-like Growth Factor (IGF), interferons (e.g., IFN- α , IFN- γ , IFN- γ), interleukins (e.g., IL-1, IL-2, IL-3, IL-4, IL-5, IL-6, IL-7, IL-8, IL-9, IL-10, IL-11, IL-12, etc.), Keratinocyte Growth Factor (KGF), Lactoferrin, leukemia inhibitory factor, Luciferase, Neurturin, Neutrophil inhibitory factor (NIF), oncostatin M, Osteogenic protein, Parathyroid hormone, PD-ECSF, PDGF, peptide hormones (e.g., Human Growth Hormone), Pleiotropin, Protein A, Protein G, Pyrogenic exotoxins A, B, and C, Relaxin, Renin, SCF, Soluble complement receptor I, Soluble I-CAM 1, Soluble interleukin receptors (IL-1, 2, 3, 4, 5, 6, 7, 9, 10, 11, 12, 13, 14, 15), Soluble TNF receptor, Somatomedin, Somatostatin, Somatotropin, Streptokinase, Superantigens, i.e., Staphylococcal enterotoxins (SEA, SEB, SEC1, SEC2, SEC3, SED, SEE), Superoxide dismutase (SOD), Toxic shock syndrome toxin (TSST-1), Thymosin alpha 1, Tissue plasminogen activator, Tumor necrosis factor beta (TNF beta), Tumor necrosis factor receptor (TNFR), Tumor necrosis factor-alpha (TNF alpha), Vascular Endothelial Growth Factor (VEGEGF), Urokinase and many others.

[0246] One class of proteins that can be made using the compositions and methods for in vivo incorporation of GalNAc amino acids described herein includes transcriptional modulators or a portion thereof. Example transcriptional modulators include genes and transcriptional modulator proteins that modulate cell growth, differentiation, regulation, or the like. Transcriptional modulators are found in prokaryotes, viruses, and eukaryotes, including fungi, plants, yeasts, insects, and animals, including mammals, providing a wide range of therapeutic targets. It will be appreciated that expression and transcriptional activators regulate transcription by many mechanisms, e.g., by binding to receptors, stimulating a signal transduction cascade, regulating expression of transcription factors, binding to promoters and enhancers, binding to proteins that bind to promoters and enhancers, unwinding DNA, splicing pre-mRNA, polyadenylating RNA, and degrading RNA.

[0247] One class of proteins of the invention (e.g., proteins with one or more GalNAc amino acids) include biologically active proteins such as cytokines, inflammatory molecules, growth factors, their receptors, and oncogene products, e.g., interleukins (e.g., IL-1, IL-2, IL-8, etc.), interferons, FGF, IGF-I, IGF-II, FGF, PDGF, TNF, TGF- α , TGF- β , EGF, KGF, SCF/c-Kit, CD40L/CD40, VLA-4/VCAM-1, ICAM-1/LFA-1, and hyalurin/CD44; signal transduction molecules and corresponding oncogene products, e.g., Mos, Ras, Raf, and Met; and transcriptional activators and suppressors, e.g., p53, Tat, Fos, Myc, Jun, Myb, Rel, and steroid hormone receptors such as those for estrogen, progesterone, testosterone, aldosterone, the LDL receptor ligand and corticosterone.

[0248] Enzymes (e.g., industrial enzymes) or portions thereof with at least one GalNAc amino acid are also provided by the invention. Examples of enzymes include, but are not limited to, e.g., amidases, amino acid racemases, acylases, dehalogenases, dioxygenases, diarylpropane peroxidases,

epimerases, epoxide hydrolases, esterases, isomerases, kinases, glucose isomerases, glycosidases, glycosyl transferases, haloperoxidases, monooxygenases (e.g., p450s), lipases, lignin peroxidases, nitrile hydratases, nitrilases, proteases, phosphatases, subtilisins, transaminase, and nucleases.

[0249] Many of these proteins are commercially available (See, e.g., the Sigma BioSciences 2002 catalogue and price list), and the corresponding protein sequences and genes and, typically, many variants thereof, are well-known (see, e.g., Genbank). Any of them can be modified by the insertion of one or more GalNAc amino acid according to the invention, e.g., to alter the protein with respect to one or more therapeutic, diagnostic or enzymatic properties of interest. Examples of therapeutically relevant properties include serum half-life, shelf half-life, stability, immunogenicity, therapeutic activity, detectability (e.g., by the inclusion of reporter groups (e.g., labels or label binding sites) in the unnatural amino acids, e.g., GalNAc amino acids), reduction of LD₅₀ or other side effects, ability to enter the body through the gastric tract (e.g., oral availability), or the like. Examples of diagnostic properties include shelf half-life, stability, diagnostic activity, detectability, or the like. Examples of relevant enzymatic properties include shelf half-life, stability, enzymatic activity, production capability, or the like.

[0250] A variety of other proteins can also be modified to include one or more GalNAc amino acid using compositions and methods of the invention. For example, the invention can include substituting one or more natural amino acids in one or more vaccine proteins with a GalNAc amino acid, e.g., in proteins from infectious fungi, e.g., *Aspergillus*, *Candida* species; bacteria, particularly *E. coli*, which serves a model for pathogenic bacteria, as well as medically important bacteria such as *Staphylococci* (e.g., aureus), or *Streptococci* (e.g., pneumoniae); protozoa such as sporozoa (e.g., *Plasmodia*), rhizopods (e.g., *Entamoeba*) and flagellates (*Trypanosoma*, *Leishmania*, *Trichomonas*, *Giardia*, etc.); viruses such as (+) RNA viruses (examples include Poxviruses e.g., vaccinia; Picornaviruses, e.g. polio; Togaviruses, e.g., rubella; Flaviviruses, e.g., HCV; and Coronaviruses), (-) RNA viruses (e.g., Rhabdoviruses, e.g., VSV; Paramyxoviruses, e.g., RSV; Orthomyxoviruses, e.g., influenza; Bunyaviruses; and Arenaviruses), dsDNA viruses (Reoviruses, for example), RNA to DNA viruses, i.e., Retroviruses, e.g., HIV and HTLV, and certain DNA to RNA viruses such as Hepatitis B.

[0251] Agriculturally related proteins such as insect resistance proteins (e.g., the Cry proteins), starch and lipid production enzymes, plant and insect toxins, toxin-resistance proteins, Mycotoxin detoxification proteins, plant growth enzymes (e.g., Ribulose 1,5-Bisphosphate Carboxylase/Oxygenase, "RUBISCO"), lipoxygenase (LOX), and Phosphoenolpyruvate (PEP) carboxylase are also suitable targets for GalNAc amino acid modification.

[0252] In certain embodiments, the protein or polypeptide of interest (or portion thereof) in the methods and/or compositions of the invention is encoded by a nucleic acid. Typically, the nucleic acid comprises at least one selector codon, at least two selector codons, at least three selector codons, at least four selector codons, at least five selector codons, at least six selector codons, at least seven selector codons, at least eight selector codons, at least nine selector codons, ten or more selector codons.

[0253] Genes coding for proteins or polypeptides of interest can be mutagenized using methods well-known to one of skill in the art and described herein under "Mutagenesis and Other Molecular Biology Techniques" to include, e.g., one or more selector codon for the incorporation of a GalNAc amino acid. For example, a nucleic acid for a protein of interest is mutagenized to include one or more selector codon, providing for the insertion of the one or more GalNAc amino acids. The invention includes any such variant, e.g., mutant, versions of any protein, e.g., including at least one GalNAc amino acid. Similarly, the invention also includes corresponding nucleic acids, i.e., any nucleic acid with one or more selector codon that encodes one or more GalNAc amino acid.

[0254] To make a protein that includes an GalNAc amino acid, one can use host cells and organisms that are adapted for the in vivo incorporation of the GalNAc amino acid via orthogonal tRNA/RS pairs. Host cells are genetically engineered (e.g., transformed, transduced or transfected) with one or more vectors that express the orthogonal tRNA, the orthogonal tRNA synthetase, and a vector that encodes the protein to be derivatized. Each of these components can be on the same vector, or each can be on a separate vector, or two components can be on one vector and the third component on a second vector. The vector can be, for example, in the form of a plasmid, a bacterium, a virus, a naked polynucleotide, or a conjugated polynucleotide.

[0255] Defining Polypeptides by Immunoreactivity

[0256] Because the polypeptides of the invention provide a variety of new polypeptide sequences (e.g., polypeptides comprising GalNAc amino acids in the case of proteins synthesized in the translation systems herein, or, e.g., in the case of the novel synthetases, novel sequences of standard amino acids), the polypeptides also provide new structural features which can be recognized, e.g., in immunological assays. The generation of antisera, which specifically bind the polypeptides of the invention, as well as the polypeptides which are bound by such antisera, are a feature of the invention. The term "antibody," as used herein, includes, but is not limited to a polypeptide substantially encoded by an immunoglobulin gene or immunoglobulin genes, or fragments thereof which specifically bind and recognize an analyte (antigen). Examples include polyclonal, monoclonal, chimeric, and single chain antibodies, and the like. Fragments of immunoglobulins, including Fab fragments and fragments produced by an expression library, including phage display, are also included in the term "antibody" as used herein. See, e.g., Paul, *Fundamental Immunology*, 4th Ed., 1999, Raven Press, New York, for antibody structure and terminology.

[0257] The invention includes novel synthetase proteins that specifically bind to, or that are specifically immunoreactive with, an antibody or antisera generated against an immunogen comprising a synthetase amino acid sequence selected from one or more of those in the various sequences herein. To eliminate cross-reactivity with other homologues, the antibody or antisera is subtracted with available synthetases, such as the wild-type *Methanococcus jannaschii* (*M. jannaschii*) tyrosyl synthetase (TyrRS), or a known artificial synthetase, such as any of those in WO 2002/085923. Where the wild-type *M. jannaschii* tyrosyl synthetase (TyrRS), or previous sequence, corresponds to a nucleic acid, a polypeptide encoded by the nucleic acid is optionally generated and used for antibody/antisera subtraction purposes.

[0258] In one typical format, the immunoassay uses polyclonal antiserum raised against one or more polypeptide com-

prising one or more of the synthetase sequences herein, or a substantial subsequence thereof (i.e., at least about 30% of the full length sequence provided). The set of potential polypeptide immunogens derived from these sequences are collectively referred to below as “the immunogenic polypeptides.” The resulting antisera is optionally selected to have low cross-reactivity against the control synthetase homologues (wild type TyrRs, and/or synthetases in WO 2002/085923) and any such cross-reactivity is removed, e.g., by immunoabsorption, with one or more of the control synthetase homologues, prior to use of the polyclonal antiserum in the immunoassay.

[0259] In order to produce antisera for use in an immunoassay, one or more of the immunogenic polypeptides is produced and purified as described herein. For example, recombinant protein can be produced in a recombinant cell. An inbred strain of mice (used in this assay because results are more reproducible due to the virtual genetic identity of the mice) is immunized with the immunogenic protein(s) in combination with a standard adjuvant, such as Freund’s adjuvant, and a standard mouse immunization protocol (see, e.g., Harlow and Lane (1988) *Antibodies, A Laboratory Manual*, Cold Spring Harbor Publications, New York, for a standard description of antibody generation, immunoassay formats and conditions that can be used to determine specific immunoreactivity. Additional references and discussion of antibodies is also found herein and can be applied here to defining polypeptides by immunoreactivity). For example, see International Publication Numbers WO 2004/094593, entitled “EXPANDING THE EUKARYOTIC GENETIC CODE;” WO 2002/085923, entitled “IN VIVO INCORPORATION OF UNNATURAL AMINO ACIDS;” WO 2004/035605, entitled “GLYCOPROTEIN SYNTHESIS;” and WO 2004/058946, entitled “PROTEIN ARRAYS.”

[0260] Alternatively, one or more synthetic or recombinant polypeptide derived from the sequences disclosed herein is conjugated to a carrier protein and used as an immunogen. Additional details on proteins, antibodies, antisera, etc. can be found in WO 2002/085923.

[0261] Polyclonal sera are collected and titered against the immunogenic polypeptide in an immunoassay, for example, a solid phase immunoassay with one or more of the immunogenic proteins immobilized on a solid support. Polyclonal antisera with a titer of 10^6 or greater are selected, pooled and subtracted with the control synthetase polypeptides to produce subtracted pooled titered polyclonal antisera.

[0262] The subtracted pooled titered polyclonal antisera are tested for cross reactivity against the control homologues in a comparative immunoassay. In this comparative assay, discriminatory binding conditions are determined for the subtracted titered polyclonal antisera which result in at least about a 5-10 fold higher signal to noise ratio for binding of the titered polyclonal antisera to the immunogenic synthetase as compared to binding to the control synthetase homologues. That is, the stringency of the binding reaction is adjusted by the addition of non-specific competitors such as albumin or non-fat dry milk, and/or by adjusting salt conditions, temperature, and/or the like. These binding conditions are used in subsequent assays for determining whether a test polypeptide (a polypeptide being compared to the immunogenic polypeptides and/ or the control polypeptides) is specifically bound by the pooled subtracted polyclonal antisera. In particular, test polypeptides which show at least a 2-5 \times higher signal to noise ratio than the control synthetase homologues under discriminatory binding conditions, and at least about a $\frac{1}{2}$

signal to noise ratio as compared to the immunogenic polypeptide(s), shares substantial structural similarity with the immunogenic polypeptide as compared to known synthetases, and is, therefore a polypeptide of the invention.

[0263] In another example, immunoassays in the competitive binding format are used for detection of a test polypeptide. For example, as noted, cross-reacting antibodies are removed from the pooled antisera mixture by immunoabsorption with the control polypeptides. The immunogenic polypeptide(s) are then immobilized to a solid support which is exposed to the subtracted pooled antisera. Test proteins are added to the assay to compete for binding to the pooled subtracted antisera. The ability of the test protein(s) to compete for binding to the pooled subtracted antisera as compared to the immobilized protein(s) is compared to the ability of the immunogenic polypeptide(s) added to the assay to compete for binding (the immunogenic polypeptides compete effectively with the immobilized immunogenic polypeptides for binding to the pooled antisera). The percent cross-reactivity for the test proteins is calculated, using standard calculations.

[0264] In a parallel assay, the ability of the control proteins to compete for binding to the pooled subtracted antisera is optionally determined as compared to the ability of the immunogenic polypeptide(s) to compete for binding to the antisera. Again, the percent cross-reactivity for the control polypeptides is calculated, using standard calculations. Where the percent cross-reactivity is at least 5-10 \times as high for the test polypeptides as compared to the control polypeptides and or where the binding of the test polypeptides is approximately in the range of the binding of the immunogenic polypeptides, the test polypeptides are said to specifically bind the pooled subtracted antisera.

[0265] In general, the immunoabsorbed and pooled antisera can be used in a competitive binding immunoassay as described herein to compare any test polypeptide to the immunogenic and/ or control polypeptide(s). In order to make this comparison, the immunogenic, test and control polypeptides are each assayed at a wide range of concentrations and the amount of each polypeptide required to inhibit 50% of the binding of the subtracted antisera to, e.g., an immobilized control, test or immunogenic protein is determined using standard techniques. If the amount of the test polypeptide required for binding in the competitive assay is less than twice the amount of the immunogenic polypeptide that is required, then the test polypeptide is said to specifically bind to an antibody generated to the immunogenic protein, provided the amount is at least about 5-10 \times as high as for the control polypeptide.

[0266] As an additional determination of specificity, the pooled antisera is optionally fully immunosorbed with the immunogenic polypeptide(s) (rather than the control polypeptides) until little or no binding of the resulting immunogenic polypeptide subtracted pooled antisera to the immunogenic polypeptide(s) used in the immunoabsorption is detectable. This fully immunosorbed antisera is then tested for reactivity with the test polypeptide. If little or no reactivity is observed (i.e., no more than 2 \times the signal to noise ratio observed for binding of the fully immunosorbed antisera to the immunogenic polypeptide), then the test polypeptide is specifically bound by the antisera elicited by the immunogenic protein.

Use of O-tRNA and O—RS and O-tRNA/O—RS Pairs

[0267] The compositions of the invention and compositions made by the methods of the invention optionally are in

a cell. The O-tRNA/O—RS pairs or individual components of the invention can then be used in a host system's translation machinery, which results in a GalNAc amino acid being incorporated into a protein. International Publication Number WO 2002/085923 by Schultz, et al., entitled "IN VIVO INCORPORATION OF UNNATURAL AMINO ACIDS," describes this process and is incorporated herein by reference. For example, when an O-tRNA/O—RS pair is introduced into a host, e.g., *Escherichia coli*, the pair leads to the in vivo incorporation of a GalNAc amino acid, which can be exogenously added to the growth medium, into a protein, e.g., a myoglobin test protein or a therapeutic protein, in response to a selector codon, e.g., an amber nonsense codon. Optionally, the compositions of the invention can be in an in vitro translation system, or in a cellular in vivo system(s). Proteins with the GalNAc amino acid can be used in any of a wide range of applications. Most notably, the GalNAc moiety incorporated into a protein can serve as a target for any of a wide range of modifications, for example, crosslinking with other proteins, with small molecules such as labels or dyes and/or biomolecules. With these modifications, incorporation of the GalNAc amino acid can result in improved therapeutic proteins and can be used to alter or improve the catalytic function of enzymes. In some aspects, the incorporation and subsequent modification of a GalNAc amino acid in a protein can facilitate studies on protein structure, interactions with other proteins, and the like.

Kits

[0268] Kits are also a feature of the invention. For example, a kit for producing a glycoprotein protein that comprises at least one saccharide moiety, e.g., GalNAc amino acid in a cell is provided, where the kit includes a container containing a polynucleotide sequence encoding an O-tRNA, and/or an O-tRNA, and/or a polynucleotide sequence encoding an O—RS, and/or an O—RS. In one embodiment, the kit further includes a GalNAc amino acid such as GalNAc- α -threonine. In another embodiment, the kit further comprises one or more polynucleotide sequences containing the selector codon (e.g., for use as a control), buffers, various containers, instructional materials for producing the glycoprotein, and the like.

In Vivo Synthesis of Glycoproteins

[0269] One can use host cells and organisms that are adapted for the in vivo incorporation of the unnatural amino acid via orthogonal tRNA/RS pairs in the methods and translation systems of the present invention. To synthesize a glycoprotein in vivo, the polynucleotide encoding a polypeptide of interest (and into which one or more selector codons have been incorporated at the positions at which attachment of a saccharide moiety is desired) is introduced into the host cell, along with an orthogonal tRNA that recognizes the selector codon, and an orthogonal aminoacyl tRNA synthetase (O—RS) that catalyzes attachment of a glycosyl-containing unnatural amino acid to the orthogonal tRNA. The glycosyl-containing amino acid is typically exogenously added to the growth medium of the host cell, although optionally it too can be synthesized in vivo by engineering a biosynthetic pathway into the host cell. To produce the glycoprotein, the O—RS attaches the unnatural amino acid to the orthogonal tRNA, which, upon presentation of the appropriate selector codon by the translation machinery, then introduces the unnatural amino acid into the nascent glycopolypeptide of interest.

[0270] Optionally, the host cells are genetically engineered (e.g., transformed, transduced or transfected) with one or more vectors that express one or more of the orthogonal tRNA, the orthogonal tRNA synthetase, and polynucleotide encoding the glycoprotein to be synthesized. These components can be on a single vector, or on a combination of vectors. Optionally, the vector can be in the form of a plasmid, a bacterium, a virus, a naked polynucleotide, or a conjugated polynucleotide.

[0271] Several well-known methods of introducing target nucleic acids into bacterial cells are available, any of which can be used in the invention. These include: fusion of the recipient cells with bacterial protoplasts containing the DNA, electroporation, projectile bombardment, and infection with viral vectors, etc. The engineered host cells can be cultured in conventional nutrient media modified as appropriate for such activities as, for example, screening steps, activating promoters or selecting transformants. These cells can optionally be cultured into transgenic organisms.

[0272] The coding regions for the orthogonal tRNA, the orthogonal tRNA synthetase, and the protein to be derivatized are operably linked to gene expression control elements that are functional in the desired host cell. Typical vectors contain transcription and translation terminators, transcription and translation initiation sequences, and promoters useful for regulation of the expression of the particular target nucleic acid. The vectors optionally comprise generic expression cassettes containing at least one independent terminator sequence, sequences permitting replication of the cassette in eukaryotes, or prokaryotes, or both (e.g., shuttle vectors) and selection markers for both prokaryotic and eukaryotic systems. Vectors are suitable for replication and/or integration in prokaryotes, eukaryotes, or preferably both. See Giliman & Smith, *Gene* 8:81 (1979); Roberts, et al., *Nature*, 328:731 (1987); Schneider, B., et al., *Protein Expr. Purif.* 6435:10 (1995); Berger and Kimmel, supra; Sambrook, supra, and Ausubel, supra. A catalogue of Bacteria and Bacteriophages useful for cloning is provided, e.g., by the ATCC, e.g., *The ATCC Catalogue of Bacteria and Bacteriophage* (1992) Ghema et al. (eds) published by the ATCC. Additional basic procedures for sequencing, cloning and other aspects of molecular biology and underlying theoretical considerations are also found in Watson et al. (1992) *Recombinant DNA Second Edition* Scientific American Books, NY. Proteins and Polypeptides of Interest.

[0273] For example, methods for producing glycoproteins include growing the cell in an appropriate medium, where the cell comprises a nucleic acid that comprises at least one selector codon and encodes a protein, providing an unnatural amino acid that includes a saccharide moiety, and incorporating the unnatural amino acid into the specified position in the protein during translation of the nucleic acid with the at least one selector codon, thereby producing the protein. Optionally, the nucleic acid comprises at least two selector codons, at least three selector codons, at least four selector codons, at least five selector codons, at least six selector codons, at least seven selector codons, at least eight selector codons, at least nine selector codons, or ten (or more) selector codons. The cell further comprises the O-tRNA that recognizes the selector codon and the O—RS that preferentially aminoacylates the O-tRNA with the glycosyl-containing unnatural amino acid. The general process is elaborated upon in PCT publication WO 2002/085923, entitled "IN VIVO INCORPORATION OF UNNATURAL AMINO ACIDS" and International

Publication WO 2004-035743 entitled "Site Specific Incorporation of Keto Amino Acids into Proteins," which are incorporated by reference.

[0274] Other useful references, e.g. for cell isolation and culture (e.g., for subsequent nucleic acid isolation) include Freshney (1994) *Culture of Animal Cells, a Manual of Basic Technique*, third edition, Wiley-Liss, New York and the references cited therein; Payne et al. (1992) *Plant Cell and Tissue Culture in Liquid Systems*, John Wiley & Sons, Inc. New York, N.Y.; Gamborg and Phillips (eds) (1995) *Plant Cell, Tissue and Organ Culture; Fundamental Methods* Springer Lab Manual, Springer-Verlag (Berlin Heidelberg New York) and Atlas and Parks (eds) *The Handbook of Microbiological Media* (1993) CRC Press, Boca Raton, Fla.

[0275] General texts which describe molecular biological techniques include Berger and Kimmel, *Guide to Molecular Cloning Techniques, Methods in Enzymology* volume 152 Academic Press, Inc., San Diego, Calif. (Berger); Sambrook et al., *Molecular Cloning—A Laboratory Manual* (3rd Ed.), Vol. 1-3, Cold Spring Harbor Laboratory, Cold Spring Harbor, N.Y., 2001 ("Sambrook") and *Current Protocols in Molecular Biology*, F. M. Ausubel et al., eds., *Current Protocols*, a joint venture between Greene Publishing Associates, Inc. and John Wiley & Sons, Inc., (supplemented through 2003) ("Ausubel"). These texts describe mutagenesis, the use of vectors, promoters and many other relevant topics related to, e.g., the generation of genes that include selector codons for production of proteins that include unnatural amino acids, orthogonal tRNAs, orthogonal synthetases, and pairs thereof.

[0276] Glycoprotein Production

[0277] A translation system, such as a cell, of the invention provides the ability to synthesize or produce glycoproteins in useful quantities. In one aspect, the glycoprotein composition produced by the methods, translation systems and/or kits of the present invention optionally includes, e.g., at least 10 micrograms, at least 50 micrograms, at least 75 micrograms, at least 100 micrograms, at least 200 micrograms, at least 250 micrograms, at least 500 micrograms, at least 1 milligram, at least 10 milligrams or more of the glycoprotein, or an amount that can be achieved with in vivo protein production methods. In another aspect, the protein is optionally present in the composition at a concentration of, e.g., at least 10 micrograms of protein per liter, at least 50 micrograms of protein per liter, at least 75 micrograms of protein per liter, at least 100 micrograms of protein per liter, at least 200 micrograms of protein per liter, at least 250 micrograms of protein per liter, at least 500 micrograms of protein per liter, at least 1 milligram of protein per liter, or at least 10 milligrams of protein per liter or more, in, e.g., a cell lysate, a buffer, a pharmaceutical buffer, or other liquid suspension (e.g., in a volume of, e.g., anywhere from about 1 nl to about 100 L). The production of large quantities (e.g., greater than that typically possible with other methods, e.g., in vitro translation) of a protein in a cell including at least one glycosyl-containing unnatural amino acid is a feature of the invention.

[0278] The incorporation of an unnatural amino acid that includes a saccharide moiety can be used to, e.g., tailor changes in protein structure and/or function, e.g., to change size, acidity, nucleophilicity, hydrogen bonding, hydrophobicity, accessibility of protease target sites, target access to a protein moiety, lectins specificity, antigenic properties, etc. Proteins that include the glycosyl-containing unnatural

amino acid can optionally have enhanced, or even entirely new, antigenic, catalytic or physical properties.

[0279] In one aspect of the invention, a composition includes at least one protein with at least one, e.g., at least two, at least three, at least four, at least five, at least six, at least seven, at least eight, at least nine, or at least ten or more unnatural amino acids, including, but not limited to, an unnatural amino acid that includes a saccharide moiety, and/or another unnatural amino acid (including unnatural amino acids having a moiety at which a saccharide can be attached; see, for example, International Publication WO 2004-035743). The unnatural amino acids can be the same or different, e.g., there can be 1, 2, 3, 4, 5, 6, 7, 8, 9, or 10 or more different sites in the protein that comprise 1, 2, 3, 4, 5, 6, 7, 8, 9, or 10 or more different unnatural amino acids. In another aspect, a composition includes a protein with at least one, but fewer than all, of a particular amino acid present in the protein substituted with the glycosyl-containing unnatural amino acid. For a given protein with more than one unnatural amino acids, the unnatural amino acids can be identical or different (e.g., the protein can include two or more different types of unnatural amino acids, or can include two of the same unnatural amino acid). For a given protein with more than two unnatural amino acids, the unnatural amino acids can be the same, different, or a combination of multiple unnatural amino acids of the same kind with at least one different unnatural amino acid.

[0280] Essentially any protein (or portion thereof) that includes a galactosamine- or glucosamine-containing unnatural amino acid (and any corresponding coding nucleic acid, e.g., which includes one or more selector codons) can be produced using the compositions and methods herein. No attempt is made to identify the hundreds of thousands of known proteins, any of which can be modified to include one or more unnatural amino acid, e.g., by tailoring any available mutation methods to include one or more appropriate selector codon in a relevant translation system. Common sequence repositories for known proteins include GenBank EMBL, DDBJ and the NCBI. Other repositories can easily be identified by searching the internet.

[0281] Defining Polypeptides by Immunoreactivity

[0282] For example, the invention includes novel synthetase proteins that specifically bind to, or that are specifically immunoreactive with, an antibody or antisera generated against an immunogen comprising a synthetase amino acid sequence selected from one or more of those in the various sequences herein. To eliminate cross-reactivity with other homologues, the antibody or antisera is subtracted with available synthetases, such as the wild-type *Methanococcus jannaschii* (*M. jannaschii*) tyrosyl synthetase (TyrRS), or a known artificial synthetase, such as any of those in WO 2002/085923. Where the wild-type *M. jannaschii* tyrosyl synthetase (TyrRS), or previous sequence, corresponds to a nucleic acid, a polypeptide encoded by the nucleic acid is optionally generated and used for antibody/antisera subtraction purposes.

[0283] In one typical format, the immunoassay uses polyclonal antiserum raised against one or more polypeptide comprising one or more of the synthetase sequences herein, or a substantial subsequence thereof (i.e., at least about 30% of the full length sequence provided). The set of potential polypeptide immunogens derived from these sequences are collectively referred to below as "the immunogenic polypeptides." The resulting antisera is optionally selected to have low cross-

reactivity against the control synthetase homologues (wild type TyrRs, and/or synthetases in WO 2002/085923) and any such cross-reactivity is removed, e.g., by immunoabsorption, with one or more of the control synthetase homologues, prior to use of the polyclonal antiserum in the immunoassay.

[0284] In order to produce antisera for use in an immunoassay, one or more of the immunogenic polypeptides is produced and purified as described herein. For example, recombinant protein can be produced in a recombinant cell. An inbred strain of mice (used in this assay because results are more reproducible due to the virtual genetic identity of the mice) is immunized with the immunogenic protein(s) in combination with a standard adjuvant, such as Freund's adjuvant, and a standard mouse immunization protocol (see, e.g., Harlow and Lane (1988) *Antibodies, A Laboratory Manual*, Cold Spring Harbor Publications, New York, for a standard description of antibody generation, immunoassay formats and conditions that can be used to determine specific immunoreactivity. Additional references and discussion of antibodies is also found herein and can be applied here to defining polypeptides by immunoreactivity). Alternatively, one or more synthetic or recombinant polypeptide derived from the sequences disclosed herein is conjugated to a carrier protein and used as an immunogen. Additional details on proteins, antibodies, antisera, etc. can be found in WO 2002/085923.

[0285] Polyclonal sera are collected and titered against the immunogenic polypeptide in an immunoassay, for example, a solid phase immunoassay with one or more of the immunogenic proteins immobilized on a solid support. Polyclonal antisera with a titer of 10^6 or greater are selected, pooled and subtracted with the control synthetase polypeptides to produce subtracted pooled titered polyclonal antisera.

[0286] The subtracted pooled titered polyclonal antisera are tested for cross reactivity against the control homologues in a comparative immunoassay. In this comparative assay, discriminatory binding conditions are determined for the subtracted titered polyclonal antisera which result in at least about a 5-10 fold higher signal to noise ratio for binding of the titered polyclonal antisera to the immunogenic synthetase as compared to binding to the control synthetase homologues. That is, the stringency of the binding reaction is adjusted by the addition of non-specific competitors such as albumin or non-fat dry milk, and/or by adjusting salt conditions, temperature, and/or the like. These binding conditions are used in subsequent assays for determining whether a test polypeptide (a polypeptide being compared to the immunogenic polypeptides and/ or the control polypeptides) is specifically bound by the pooled subtracted polyclonal antisera. In particular, test polypeptides which show at least a 2-5 \times higher signal to noise ratio than the control synthetase homologues under discriminatory binding conditions, and at least about a $\frac{1}{2}$ signal to noise ratio as compared to the immunogenic polypeptide(s), shares substantial structural similarity with the immunogenic polypeptide as compared to known synthetases, and is, therefore a polypeptide of the invention.

[0287] In another example, immunoassays in the competitive binding format are used for detection of a test polypeptide. For example, as noted, cross-reacting antibodies are removed from the pooled antisera mixture by immunoabsorption with the control polypeptides. The immunogenic polypeptide(s) are then immobilized to a solid support which is exposed to the subtracted pooled antisera. Test proteins are added to the assay to compete for binding to the pooled subtracted antisera. The ability of the test protein(s) to com-

pete for binding to the pooled subtracted antisera as compared to the immobilized protein(s) is compared to the ability of the immunogenic polypeptide(s) added to the assay to compete for binding (the immunogenic polypeptides compete effectively with the immobilized immunogenic polypeptides for binding to the pooled antisera). The percent cross-reactivity for the test proteins is calculated, using standard calculations.

[0288] In a parallel assay, the ability of the control proteins to compete for binding to the pooled subtracted antisera is optionally determined as compared to the ability of the immunogenic polypeptide(s) to compete for binding to the antisera. Again, the percent cross-reactivity for the control polypeptides is calculated, using standard calculations. Where the percent cross-reactivity is at least 5-10 \times as high for the test polypeptides as compared to the control polypeptides and or where the binding of the test polypeptides is approximately in the range of the binding of the immunogenic polypeptides, the test polypeptides are said to specifically bind the pooled subtracted antisera.

[0289] In general, the immunoabsorbed and pooled antisera can be used in a competitive binding immunoassay as described herein to compare any test polypeptide to the immunogenic and/ or control polypeptide(s). In order to make this comparison, the immunogenic, test and control polypeptides are each assayed at a wide range of concentrations and the amount of each polypeptide required to inhibit 50% of the binding of the subtracted antisera to, e.g., an immobilized control, test or immunogenic protein is determined using standard techniques. If the amount of the test polypeptide required for binding in the competitive assay is less than twice the amount of the immunogenic polypeptide that is required, then the test polypeptide is said to specifically bind to an antibody generated to the immunogenic protein, provided the amount is at least about 5-10 \times as high as for the control polypeptide.

[0290] As an additional determination of specificity, the pooled antisera is optionally fully immunosorbed with the immunogenic polypeptide(s) (rather than the control polypeptides) until little or no binding of the resulting immunogenic polypeptide subtracted pooled antisera to the immunogenic polypeptide(s) used in the immunosorption is detectable. This fully immunosorbed antisera is then tested for reactivity with the test polypeptide. If little or no reactivity is observed (i.e., no more than 2 \times the signal to noise ratio observed for binding of the fully immunosorbed antisera to the immunogenic polypeptide), then the test polypeptide is specifically bound by the antisera elicited by the immunogenic protein.

EXAMPLES

[0291] The following examples are offered to illustrate, but not to limit the invention. It is understood that the examples and embodiments described herein are for illustrative purposes only and that various modifications or changes in light thereof will be suggested to persons skilled in the art and are to be included within the spirit and purview of this application and scope of the appended claims.

[0292] The present invention provides a mechanism by which the genetic code of an organism, e.g., *E. coli*, can be extended to include the addition of glycosylated amino acids,

to which additional sugar residues can optionally be attached, thereby generating glycoproteins having specified sites of glycosylation.

Example 1

System for Incorporating a Glycosylated Amino Acid into Proteins

[0293] In eukaryotes, mucins comprise the most prevalent type of O-glycans, constituting a polydisperse group of glycoproteins and proteoglycans involved in inflammation and cellular recognition (Hanisch (2001) *Biol. Chem.* 382:143-149). The N-acetylgalactosamine (GalNAc) saccharide α -linked to the hydroxyl group of threonine or serine represents the core unit (the "Tn antigen") in mucin-type glycoproteins. A wide variety of mucin-type core structures are generated by subsequent glycosylation of the GalNAc residue at the C-3 and/or C-6 hydroxyl groups.

[0294] This example describes methods and compositions for preparing N-acetylgalactosamine- α -threonine (GalNAc-Thr) and co-translationally incorporating this unnatural amino acid into a protein in vivo. In order to genetically encode this functional group in *E. coli* in the form of GalNAc-threonine, a number of tRNA-synthetase pairs were evolved that are capable of inserting this glycosyl-containing amino acid site-specifically into proteins in *E. coli* in response to (and only in response to) an amber nonsense codon. The tRNA-synthetase pair is orthogonal to its counterparts for the common 20 amino acids, i.e., the orthogonal synthetase (and only this synthetase) aminoacylates the orthogonal tRNA (and only this tRNA) with the unnatural amino acid only, and the resulting acylated tRNA inserts the unnatural amino acid only in response to the amber codon.

Materials and Methods

[0295] All chemicals were purchased from Sigma-Aldrich unless otherwise noted. DNA sequencing was provided by the Protein and Nucleic Acids Core Facility at the Scripps Research Institute. Mass spectral analysis was carried out by the Scripps Center for Mass Spectrometry, Professor Joseph A. Loo (University of California, Los Angeles), and Professor Yu-Ju Chen (Academia Sinica, Taiwan).

[0296] Preparation of GalNAc-Threonine

[0297] The peracetylated version of N-acetylgalactosamine- α -threonine 2 was prepared from galactosamine by modifying a chemical synthetic approach described by Koeller et al ("Chemoenzymatic synthesis, of PSGL-1 glycopeptides: Sulfation on tyrosine affects glycosyltransferase-catalyzed synthesis of the O-glycan" (2000) *Bioorganic and Medicinal Chemistry* 8:1017-1025), as depicted in FIG. 2.

[0298] NMR spectroscopic data of 2 was obtained using a Bruker DRX-600: ^1H NMR (600 MHz, D_2O) δ 1.45 (d, $J=7.0$ Hz, 3H), 2.02 (s, 3H), 2.04 (s, 3H), 2.10 (s, 3H), 2.22 (s, 3H), 3.78 (brs, 1H), 4.18-4.25 (m, 2H), 4.42 (dd, $J=10.9, 3.5$ Hz, 1H), 4.49-4.50 (m, 2H), 5.10 (d, 3.5 Hz, 1H), 5.19 (dd, $J=11.4, 2.6$ Hz, 1H), 5.45 (brs, 1H); ^{13}C NMR (125 MHz, D_2O) δ 20.90, 20.91, 20.97, 48.49, 59.86, 63.44, 67.99, 68.92, 69.56, 76.37, 100.22, 172.53, 173.89, 174.21, 174.38, 175.27; MALDI-FTMS of 2 was acquired on an IonSpec FTMS mass spectrometer: m/z 471.1586 ($\text{C}_{18}\text{H}_{28}\text{N}_2\text{O}_{11}\text{Na}$, $[\text{M}+\text{Na}]^+$ calculated 471.1585).

[0299] Directed Evolution of Mutant Synthetases

[0300] An orthogonal *Methanococcus jannaschii* tyrosyl-tRNA synthetase (TyrRS) and a mutant tyrosine amber sup-

pressor tRNA ($\text{mutRNA}_{\text{CUA}}^{\text{Tyr}}$) were used as the starting point for the generation of tRNA synthetases that accept glycosyl amino acids (such as GalNAc- α -O-threonine and GalNAc- α -O-serine). To change the amino acid specificity of the TyrRS so that it charges the tRNA with a glycosyl amino acid, *M. jannaschii* TyrRS mutants were generated and screened as follows.

[0301] For the first round of positive screening, competent *E. coli* DH10 β cells containing plasmid pREP/YC-JYCUA (Santoro et al (2002) *Nat. Biotechnol.* 20:1044-11048) were transformed with a combination of two *M. jannaschii* TyrRS libraries: pBK-lib-m (with residues Tyr32, Ala67, His70, Gln155, Asp158, and Ala167 randomized) and pBK-lib (with residues Tyr32, Glu107, Asp158, Ile159, and Leu162 randomized). The combined library had approximately 2.6×10^9 independent clones.

[0302] The transformed cells were grown at 37° C. in 500 mL of glycerol minimal medium with leucine (GMML, 1 \times M9 minimal medium, 1% glycerol, 1 mM MgCl_2 , 0.1 mM CaCl_2 , 0.5% NaCl, and 0.3 mM leucine) containing 50 $\mu\text{g}/\text{mL}$ kanamycin, 24 $\mu\text{g}/\text{mL}$ tetracycline, 68 $\mu\text{g}/\text{mL}$ chloramphenicol, and 1 mM of 2. After 60 hours, the plasmids were extracted from the surviving cells and transformed into DH10 β containing plasmid pLWJ17B3 as described by Wang and Schultz (*Chem. Biol.* 8:883-890, 2002). The transformants were spread on Luria-Bertani plates containing 50 $\mu\text{g}/\text{mL}$ kanamycin, 68 $\mu\text{g}/\text{mL}$ chloramphenicol, and 0.02% L-arabinose, and incubated at 37° C. for 10 hours. The surviving cells were collected, and the plasmids were purified for the next round of positive screening.

[0303] Four rounds of positive screening alternating with three rounds of negative screening were performed, which yielded four clones of MjTyrRS mutants that demonstrated increased chloramphenicol resistance in the presence of 2. The isolated mutants also exhibited higher expression levels of GFPuv when grown in the presence of glycosyl amino acid 2 than without it, as indicated by emitted fluorescence from the cell colonies. Mutations of the evolved synthetase mutants are listed in Table 2.

TABLE 2

Amino acid residues in the wild type <i>M. jannaschii</i> (Mj) TyrRS and the evolved mutant synthetases with specificities for GalNAc-threonine					
Amino acid residue	Synthetase Isolate				
	I-90	AH1	C8F	C10F	D10B
Tyr32		Phe	Gln	Ala	Leu
Ala67		Pro	Pro	Ser	Thr
His70				Pro	Lys
Leu98				Ile	
Val149					Ile
Glu107	Pro				
Gln155					Ser
Asp158	Cys				Val
Ile 159	Tyr				
Leu162	Arg				
Gly163			Cys		
Ala167			Val		Val

[0304] Protein Expression Purification and Characterization

[0305] A mutated myoglobin sequence (in which Gly4 is mutated to amber codon TAG), selected MjTyrRS mutants (AH1 and C10F, independently), and mutant Tyr-tRNA_{CUA}

genes were co-expressed in *E. coli* DH10 β cells. The culture was grown in 500 mL of GMML with 50 μ g/mL kanamycin, 24 μ g/mL tetracycline, and 1 mM of 2 until an OD₆₀₀ of 0.6 was reached. Protein expression was then induced by adding L-arabinose to a final concentration of 0.02%, followed by 8 hours of growth at 30° C. with aeration. Cells were harvested and lysed, and the proteins were purified using Ni²⁺-NTA affinity chromatography under native conditions (Qiagen Inc., Valencia, Calif.). Proteins were analyzed by 10% NuPAGE Bis-Tris Gel and stained with Simpli Blue Safestain (Invitrogen, Carlsbad, Calif.). The molecular weight of the obtained protein products were analyzed by coupled reverse-phase liquid chromatography electrospray ionization time-of-flight (LC ESI-TOF) mass spectrometry.

[0306] Enzyme-Linked Lectin-Binding Assay (ELLA)

[0307] The GalNAc- α -Thr specific lectins Vicia Villosa lectin (VVL) and Dolichos Biflorus (DBL) were purchased as biotinylated conjugates from Vector Laboratories (Burlingame, Calif.). Purified myoglobin samples were aliquoted (600 ng) into high-binding microtiter plates (Maxisorp, Nunc). The plates were blocked in PBS containing 3% BSA, and then treated with lectin (10 μ g/mL in PBS). After three PBS washes, alkaline phosphatase (AP) conjugated to streptavidin (AP-St, Roche) was added to each well (1 U/mL in PBS). Following lectin treatment, the plate was washed three times before the AP substrate, p-nitrophenol phosphate (pNPP), was added (1 mg/mL pNPP in 10 mM diethanolamine buffer, pH 9.5, containing 0.5 mM MgCl₂). AP activity was monitored at 405 nm. As depicted in FIG. 3, an increased signal for myoglobin was detected for samples grown in the presence of GalNAc- α -Thr.

Results and Discussion

[0308] N-acetylgalactosamine α -O-threonine (GalNAc- α -Thr, 1) was genetically encoded in *E. coli* using evolved *M. jannaschii* Tyr-tRNA synthetases (MjTyrRS), coupled with a mutant tRNA for the selector codon (SEQ ID NO: 17). To enhance the cell membrane permeability of the unprotected glycosyl amino acid 1, per-acetylated GalNAc- α -Thr (2) was chemically synthesized as described herein; the acetyl groups are removed (e.g., by nonspecific esterases) once in the cytosol of cells.

[0309] Mutant MjTyrRS synthetases specific for 1 were evolved from two previously described MjTyrRS mutant libraries (Zhang 2004, supra) using a positive selection based on suppression of: 1) the nonessential mutation Asp112TAG in chloramphenicol acetyl transferase gene, which confers antibiotic resistance, and 2) the nonessential mutations Met1TAG and Gln107TAG in T7 RNA polymerase gene, which drives the expression of a green fluorescence protein, GFPuv (Wang et al. (2001) *Science* 292:498-500; Santoro 2002, supra). Negative selection based on suppression of amber codons at three permissive positions (Gln2, Asp44, and Gly65) in the toxic bamase gene was used to remove MjTyrRS mutants that accept endogenous natural amino acids. After four rounds of positive selection and three rounds of negative selection, several MjTyrRS mutants were isolated that allowed cell growth at high concentrations of chloramphenicol when supplied with 2 (FIG. 1 and Table 1).

[0310] The isolated MjTyrRS clones that accept GalNAc- α -Thr were sequenced and have the following mutations: AH1: Tyr32Phe and Ala67Pro; C8F: Tyr32Gln, Ala67Pro, Gly163Cys, and Ala167Val; C10F: Tyr32Ala, Ala67Ser, His70Pro, and Leu98Ile; D10B: Tyr32Leu, Ala67Thr,

His70Lys, Val149Ile, Gln155Ser, Asp158Val, and Ala167Val. Notably, Tyr32, which establishes one of two key hydrogen bonds to the native tyrosine substrate, is mutated in all of the GalNAc- α -Thr mutants (Kobayashi (2003) *Nat. Struct. Biol.* 10:425-432). The other major hydrogen bond donor, Asp158, is mutated in the GlcNAc- β -Ser synthetase, I-90 (Table 2). Most of the other mutations in the glycosylated-amino acid accepting synthetases appear to occur outside the active-site, based on modeling.

[0311] To confirm that the phenotypes demonstrated by the above MjTyrRS mutants result from the incorporation of 2 in response to TAG, a myoglobin mutant was co-expressed with the evolved MjTyrRS clone (FIG. 3A). The codon for the fourth amino acid in the myoglobin gene was mutated to the amber codon TAG, and a 6 \times His tag was added to the C-terminal of the gene to facilitate the purification of the full-length protein by Ni²⁺-NTA affinity chromatography. In the presence of 2, clones AH1 and C10F yielded 2 mg/L and 4 mg/L of purified protein, respectively, while the yield of wild-type myoglobin was approximately 5.5 mg/L under identical conditions. Full length protein was not produced in the absence of either tRNA_{CUA} or mutant synthetase, however, Coomassie-stained SDS-PAGE analysis revealed light myoglobin bands (roughly 10% of the positive sample) when grown in the absence of 2, indicating some residual background suppression.

[0312] Further confirmation of GalNAc- α -Thr incorporation was obtained using an enzyme-linked lectin-binding assay using lectins from Vicia Villosa (VVL) and *Dolichous Biflorus* (DBL). VVL is well known for its specificity toward the Tn antigen, while DBL is frequently used to detect α -linked GalNAc residues (see, for example, Wu (2004) *FEBS Lett.* 562:51-58). Binding of biotinylated lectins to myoglobin and glycomyoglobin samples was measured by streptavidin-alkaline phosphatase activity on the colorimetric p-nitrophenyl phosphate substrate. When treated with VVL and DBL a 10- and 5-fold signal increase, respectively, was observed for glycomyoglobin versus equivalent concentrations of tyrosine-myoglobin (FIG. 4). This data supports that GalNAc- α -Thr has been incorporated into myoglobin during in vivo biosynthesis.

developed a general approach to co-translationally incorporate glycosyl amino acids into proteins in vivo

Example 2

Strategy for the Synthesis of Glycoproteins

[0313] In another embodiment of the invention, homogeneous glycoproteins are synthesized in an organism, e.g., *E. coli*, by the cotranslational incorporation of the glycosylated amino acid N-acetylglucosamine- β -serine (GlcNAc-Ser). For example, myoglobin containing β -GlcNAc-serine at a defined position can be expressed in *E. coli* in good yield and with high fidelity. The β -GlcNAc moiety can be recognized by a carbohydrate binding protein or subsequently modified with a galactosyltransferase. This approach can also be applicable to other posttranslational modifications, e.g., protein phosphorylation, acetylation, methylation and the like.

[0314] Methods were previously developed which for the first time allowed the systematic addition of amino acids with novel chemical and physical properties to the genetic code of *E. coli* (see, e.g., L. Wang, et al., (2001) *Science* 292:498; L. Wang, et al., (2002) *J. Am. Chem. Soc.* 124:1836; Z. Zhang, et al., (2002) *Angew. Chem. Int. Ed. Engl.* 41:2840; J. W. Chin et

al., (2002) *J. Am. Chem. Soc.* 124:9026; J. W. Chin et al., (2002) *Proc. Natl. Acad. Sci. USA* 99:11020; S. W. Santoro, et al., (2002) *Nat. Biotechnol.* 20:1044; L. Wang, et al., (2003), *Proc. Natl. Acad. Sci. USA* 100:56; and, Z. Zhang et al., (2003) *Biochemistry* 42:6735) and yeast (see, e.g., J. W. Chin et al., *Science*, (2003 in press). In this approach, an amber suppressor *M. jannaschii* TyrRS—mu tRNA_{CUA}^{Tyr} pair that does not cross-react with endogenous tRNAs and synthetases is evolved to uniquely charge a desired unnatural amino acid. This methodology can also allow one to directly incorporate glycosylated, phosphorylated, or methylated amino acids into proteins (see, e.g., T. Arslan, et al., (1997) *J. Am. Chem. Soc.* 119:10877), avoiding the need for selective enzymatic or chemical posttranslational modification of proteins.

[0315] β -O-GlcNAc-L-serine 5 (see Table 2) was site-specifically incorporated into proteins in *E. coli*. The O-GlcNAc modification is ubiquitous in nearly all eukaryotes, is involved in regulation of cell signaling, protein trafficking and cell growth, and is also a substrate from which more complex carbohydrates are generated. See, e.g., L. Wells, et al., (2001) *Science* 291:2376; and, N. Lamarre-Vincent, & L. Hsieh-Wilson, (2003) *J. Am. Chem. Soc.* 125:6612. Unfortunately, saccharide derivatives with free hydroxyl groups are transferred poorly across the membrane of eukaryotic cells, suggesting that substrate 5 would unlikely be cell-permeable. See, e.g., A. K. Sarkar, et al., (1995), *Proc. Natl. Acad. Sci. USA* 92:3323. However, it has been shown that acetylation of the hydroxyl groups of sugars facilitates transport across cell membranes and that the hydroxyl acetyl groups can be deacetylated by nonspecific cytosolic esterases once inside the cell. See, e.g., N. Lamarre-Vincent, & L. Hsieh-Wilson, (2003) *J. Am. Chem. Soc.* 125:6612. Therefore, the acetylated derivative tri-acetyl- β -GlcNAc-serine 6, for which there is a commercially available precursor, N-Fmoc-tri-acetyl- β -GlcNAc-serine, was used in these experiments. Compound:

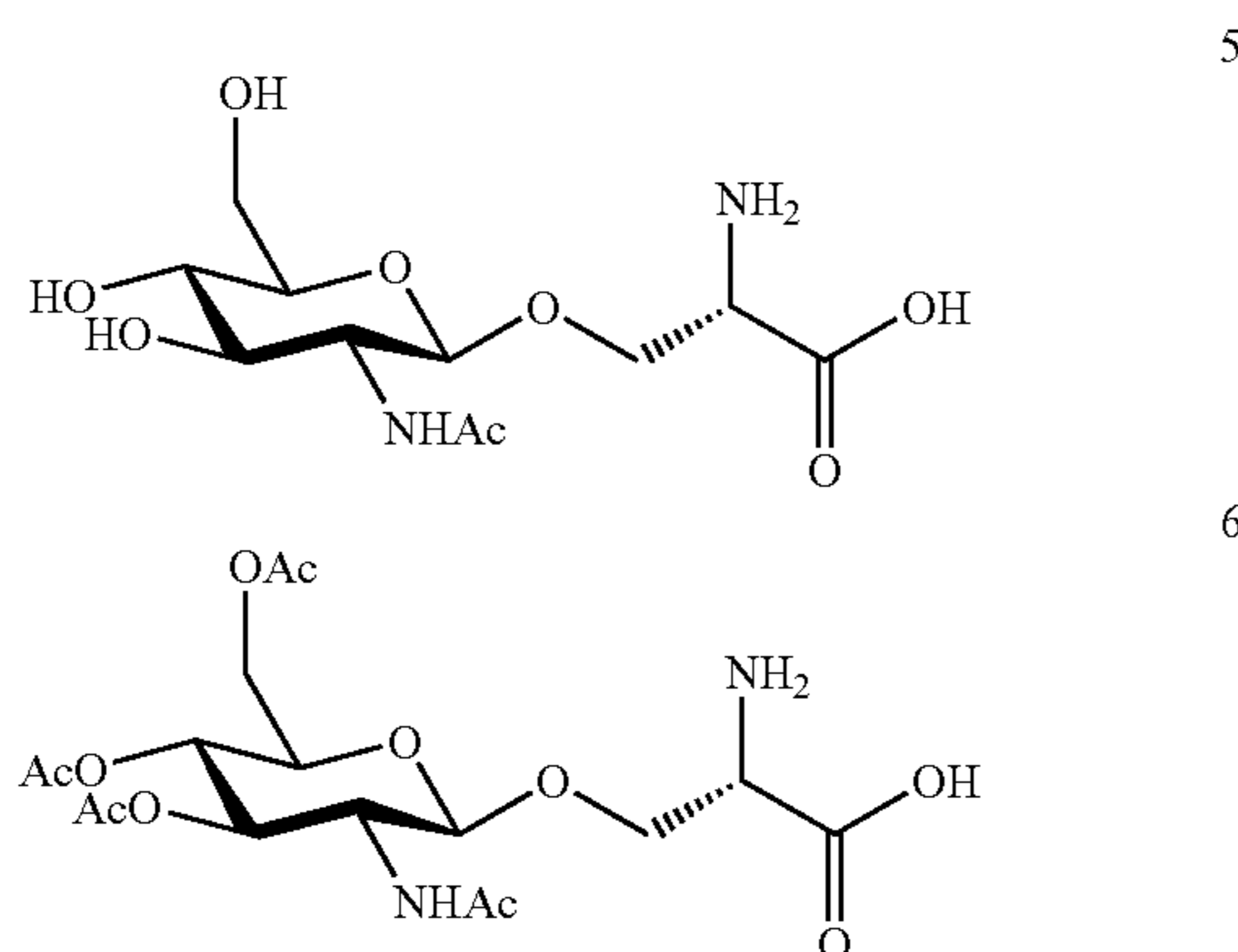

[0316] A series of positive and negative selections was used to isolate from a library of active site mutants, a TyrRS that specifically charges the orthogonal mu tRNA_{CUA}^{Tyr} with β -GlcNAc-serine in *E. coli*. Based on the X-ray structure of the homologous *Bacillus stearothermophilus* TyrRS, two libraries were constructed with active site residues randomized: one, encoded by plasmid pBK-lib-m, had residues Tyr³², Ala⁶⁷, His⁷⁰, Gln¹⁵⁵, Asp¹⁵⁸, and Ala¹⁶⁷ randomized, and a second, encoded by plasmid pBK-lib, had residues Tyr³², Glu¹⁰⁷, Asp¹⁵⁸, Ile¹⁵⁹, and Leu¹⁶² randomized. These residues are all within 6.9 Å of the phenyl ring and are the

primary residues that form the substrate binding pocket. The combined library had approximately 2.6×10^9 independent clones. This library was then subjected to a positive selection, based on suppression of an amber codon introduced at Asp112 in the chloramphenicol acetyltransferase (CAT) gene, to select TyrRS mutants capable of incorporating the glycosylated amino acid. Cells surviving at high concentrations of chloramphenicol must express a mutant TyrRS with the ability to insert either β -GlcNAc-serine or an endogenous amino acid in response to the Asp112TAG amber codon. A negative selection, based on suppression of three amber codons in the toxic bamase gene, was then used to delete from the selected clones those mutant TyrRSs that incorporate endogenous amino acids. After five rounds of positive selection and four rounds of negative selection, three clones emerged which survived at high concentration of chloramphenicol. These clones and their mutations are as following: S1-90 (Glu¹⁰⁷→Pro¹⁰⁷, Asp¹⁵⁸→Cys¹⁵⁸, Ile¹⁵⁹→Tyr¹⁵⁹, Leu¹⁶²→Arg¹⁶²), S4-5 (Tyr³²→Gly³², Glu¹⁰⁷→Gly¹⁰⁷, Asp¹⁵⁸→Cys¹⁵⁸, Leu¹⁶²→His¹⁶²), S1-5 (Glu¹⁰⁷→Cys¹⁰⁷, Asp¹⁵⁸→His¹⁵⁸, Ile¹⁵⁹→Asp¹⁵⁹, Leu¹⁶²→Met¹⁶²). All of these clones appear to be highly selective for β -GlcNAc-serine, since replacement of 6 with 1 mM of serine, α -tri-acetyl-GalNAc-threonine 2, α/β -tri-acetyl-GalNAc-serine 4 or β -tetra-acetyl-Glu-asparagine does not permit cell growth above 30 μ g/ml of chloramphenicol. These in vivo genetic results suggest that the newly selected mutant TyrRSs have excellent specificity towards β -GlcNAc-L-serine 5.

[0317] To test the efficiency and fidelity of incorporation of 5, a mutant myoglobin gene (Gly4TAG) containing an amber codon at the fourth position and a C terminal His6 tag was generated. See, e.g., S. W. Santoro et al., (2002) *Nat. Biotechnol.* 20:1044. When the mutant synthetase, S1-90, was co-expressed with the mu tRNA_{CUA}^{Tyr} and Gly4TAG myoglobin genes in the presence of 6 in minimal media, 1 mg/L of the full length mutant myoglobin was produced (See FIG. 5). For comparison, 5.5 mg/L of wild-type myoglobin was produced under similar condition, indicating a good level of suppression for S1-90. In the absence of either S1-90, mu tRNA_{CUA}^{Tyr}, or 6, no expression of full-length myoglobin was observed by silver-stained SDS-PAGE (See FIG. 5).

[0318] FIG. 5A, illustrates expression of the Gly4-mutant myoglobin (~18.5 kDa). Proteins were purified by Ni²⁺-affinity chromatography and resolved by SDS-PAGE. The gel was silver-stained. Lane 1 shows myoglobin was expressed in the presence of the orthogonal tRNA, synthetase S1-90, and Compound 6. The band at ~18 kDa corresponds to the full-length myoglobin. Lane 2 shows proteins eluted after expression in the presence of the orthogonal tRNA and the synthetase S1-90 but in the absence of substrate 6. Lane 3 shows proteins eluted after expression in the presence of the orthogonal tRNA and substrate 6 but in the absence of synthetase S1-90. Lane 4 shows proteins eluted after expression in the presence of the synthetase S1-90 and substrate 6 but in the absence of the orthogonal tRNA. Lane 5 contains the purified wild type myoglobin for comparison.

[0319] High resolution MALDI-TOF analysis (FIG. 5B) afforded a monoisotopic mass of the His6 tag-purified mutant myoglobin of 18430.1 Da, which agrees within 32 ppm with the theoretical mass of myoglobin containing Glc(OH)₃Nac-serine without methionine ($M_{theoretical}$ =18429.5 Da). Note that the loss of the N terminal Met is common in *E. coli*. In addition, no signals corresponding to either the O-acetylated glycomyoglobin or the wild-type myoglobin were observed.

The mass spectrum data confirm a high degree of specificity for the incorporation of GlcNAc-serine into myoglobin ($\geq 96\%$).

[0320] Several additional experiments were performed to further characterize the mutant myoglobin. First, an ELISA-like assay was used to analyze the binding of a GlcNAc-specific lectin, *Bandeiraea simplicifolia* II (BSII) (see, e.g., S. Ebisu, et al., (1978), *Carbohydr. Res.* 61:129), to wild-type myoglobin and glyco-myoglobin. FIG. 6A illustrates binding of a GlcNAc-specific lectin, *Bandeiraea simplicifolia* II (BSII), to wild-type myoglobin and glycomyoglobin. A_{405} values are shown for wild-type myoglobin, glycomyoglobin, and negative control (no lectin added). The glycosyl-containing mutant myoglobin (200 ng) and wild type myoglobin (200 ng) were immobilized in microtiter plate wells and subsequently incubated with biotinylated BSII and streptavidin-alkaline phosphatase conjugate. Wells were incubated with p-nitrophenyl phosphate and monitored by measuring the absorbance at 405 nm. The two forms of myoglobin were immobilized in microtiter plate wells and then incubated with biotinylated BSII, streptavidin-alkaline phosphatase conjugate, and p-nitrophenyl phosphate, respectively. Wells containing wild-type myoglobin afforded a signal equivalent to negative control wells. In contrast, wells containing glycomyoglobin produced a signal at least 200 fold higher than that of wild-type myoglobin, demonstrating selective recognition by the GlcNAc-specific lectin. In addition, this result shows that the carbohydrate has not been modified to other isomeric forms such as GalNAc and ManNAc since this lectin is highly selective for GlcNAc (see, e.g., S. Ebisu, et al., (1978), *Carbohydr. Res.* 61:129).

[0321] We also investigated whether the O-GlcNAc-serine residue in myoglobin could be selectively modified with a galactosyltransferase. Beta-1,4-galactosyltransferase is known to transfer galactose (Gal) from the sugar nucleotide UDP-Gal to the 4 position of an N-acetylglucosamine (GlcNAc) to form Gal β 1,4GlcNAc. To determine if the O-glycosylated myoglobin can be modified with UDP-Gal, both wild-type and O-glycosylated myoglobin were resolved by SDS-PAGE and transferred to a PVD membrane. The membrane was then incubated with bovine milk galactosyltransferase and radioactive UDP-[H^3]-galactose at room temperature for 24 hours. See, e.g., K. Kamemura, et al., (2002), *J. Biol. Chem.* 277:19229. Incorporation of [H^3]-Gal was monitored by exposing the membrane to X-ray film. Only the glycomyoglobin was labeled; no detectable signal was observed for the wild-type myoglobin. FIG. 6B illustrates on-blot galactosyltransferase labeling glycomyoglobin with UDP-[H^3]galactose. Wild type myoglobin (1 μ g) and glycosyl-containing mutant myoglobin (1 μ g) were resolved by 12% SDS-PAGE and transferred to a PVD membrane. The membrane was then treated with bovine milk galactosyltransferase (1 U), UDP-[H^3]galactose (0.5 μ Ci) and calf intestinal alkaline phosphatase (1 U) for 24 hours at room temperature. After extensive washes, the membrane was exposed to X-ray film using Enhanced autoradiography.

[0322] For quantitative analysis, the glycosyl transfer reaction was also carried out in solution. See, e.g., K. Witte, et al., (1997) *J. Am. Chem. Soc.* 119:2114. After incubation for 48 hours at room temperature, a 72% yield of disaccharide was obtained based on the radiolabel present. FIG. 6C illustrates quantitative analysis of the galactosyltransferase reaction, which was carried out in solution, and the radiolabeled galactose was normalized such that 1.0 corresponds to 100% trans-

fer. To the solutions containing HPLC-purified wild type myoglobin (100 μ g) and glycosyl-containing mutant myoglobin (100 μ g) were added pyruvate kinase (5 U), UDP-glucose pyrophosphorylase (1 U), inorganic pyrophosphorylase (10 U), galactose-1-phosphate-uridylyl transferase (1 U), bovine milk galactosyltransferase (2 U), glucose-1-phosphate (3 μ mol), uridylyl diphosphate (3 μ mol), phosphoenolpyruvate (0.01 mmol), and DTT (2 μ mol). After the reaction was adjusted to pH 7.2, [H^3]-galactose-1-phosphate (0.01 mmol) was added. The reaction was carried out for 48 hours at room temperature. Protein products were separated with a PD-10 Sephadex 25 column. Incorporated radiolabel was measured on a liquid scintillation analyzer.

[0323] These studies demonstrate that β -GlcNAc-L-serine can be cotranslationally incorporated into proteins in *E. coli* with excellent specificity and good yield. The incorporated β -GlcNAc-serine can serve as a primary glycosylation site to which saccharides can be added sequentially with glycosyltransferase, e.g., K. Kamemura, et al., (2002), *J. Biol. Chem.* 277:19229.

[0324] Materials and Methods

[0325] Directed evolution of mutant TyrRS enzymes. The general procedures for the positive and negative selections have been reported previously. See, e.g., Z. Zhang et al., (2003) *Biochemistry*, 42:6735. Briefly, a combination of plasmid pBK-lib-m (see, e.g., Z. Zhang et al., (2003) *Biochemistry* 42:6735) and pBK-lib (see, e.g., L. Wang, et al., (2001) *Science* 292:498) was transformed into competent *E. coli* DH10B harboring the plasmid pRep(2)/YC (see, e.g., S. W. Santoro, et al., (2002) *Nat. Biotechnol.* 20:1044). The transformed cells were grown in 500 ml of GMML medium (1 \times M9 minimal media with 1% glycerol, 0.3 mM leucine, 1 mM MgCl₂, 0.1 mM CaCl₂ and 0.5% NaCl) containing 40 μ g/ml tetracycline, 50 μ g/ml kanamycin, 68 μ g/ml chloramphenicol, and 1 mM Compound B for 60 hours at 37 $^{\circ}$ C. Plasmids (pBK) were purified from surviving cells and transformed into *E. coli* DH10B harboring pLWJ17B3 (see, e.g., L. Wang, et al., (2001) *Science* 292:498) to start the negative selection. Cells were then plated onto LB (Luria-Bertani) plates containing 40 μ g/ml chloramphenicol, 50 μ g/ml kanamycin, and 0.02% L-arabinose and incubated at 37 $^{\circ}$ C. for 8 hours. Plasmids pBK were purified from surviving cells and used for the subsequent positive and negative selections. After five rounds of positive and four rounds of negative selections, three candidate pairs of orthogonal tRNA-synthetases that conferred substrate-dependent chloramphenicol resistance were isolated and sequenced.

[0326] Expression and characterization of mutant myoglobin. DH10B cells containing pBAD/JYAMB-4TAG (see, e.g., S. W. Santoro, et al., (2002) *Nat. Biotechnol.* 20:1044) and pS1-90 were grown in a 500 ml GMML culture containing kanamycin, tetracycline, 0.02% L-arabinose, 5 μ M FeCl₃, and 0 or 1 mM of Compound 6. The cells were pelleted, lysed, and the proteins were purified by affinity chromatography with Ni²⁺-NTA beads under native conditions. Proteins were analyzed by 12% SDS-PAGE and silver-stained. Aliquots of purified proteins were subject to high resolution mass spectrometric analysis. Matrix-assisted laser desorption ionization (MALDI) with a time-of-flight (TOF) mass spectrometer (Voyager DE-STR, Applied Biosystems, Foster City, Calif.) was used to measure the molecular weight of the protein. Protein samples were desorbed and ionized upon irradiation from a 337 nm nitrogen laser. Sinapinic acid was used as the MALDI matrix. Lectin binding and glycosyltransferase reac-

tions were carried out following the established protocols (see, e.g., K. Kamemura, et al., (2002), *J. Biol. Chem.* 277: 19229; and, K. Witte, et al., (1997) *J. Am. Chem. Soc.* 119: 2114).

Example 3

Sequences of Exemplary O—RSs

[0327] Exemplary O—RSs that can be used in the invention include SEQ ID NOS.: 1-4 and 11-13 (See Table 3), and exemplary O-tRNA that can be used in the invention includes SEQ ID NO: 17. Exemplary polynucleotides that encode O—RSs include SEQ ID NOS.: 6-9 and 14-16.

[0328] It is understood that the examples and embodiments described herein are for illustrative purposes only and that various modifications or changes in light thereof will be sug-

gested to persons skilled in the art and are to be included within the spirit and purview of this application and scope of the appended claims.

[0329] While the foregoing invention has been described in some detail for purposes of clarity and understanding, it will be clear to one skilled in the art from a reading of this disclosure that various changes in form and detail can be made without departing from the true scope of the invention. For example, all the techniques and apparatus described above can be used in various combinations. All publications, patents, patent applications, and/or other documents cited in this application are incorporated by reference in their entirety for all purposes to the same extent as if each individual publication, patent, patent application, and/or other document were individually indicated to be incorporated by reference for all purposes.

TABLE 3

EXAMPLES OF SEQUENCES	
Description	Sequences
SEQ ID NO: 1 GalNAc- α -threonine aminoacyl-tRNA synthetase isolate-AH1 amino acid sequence (derived from wild-type <i>Methanococcus jannaschii</i> tyrosyl tRNA-synthetase), having amino acid changes: Tyr32Phe Ala67Pro	MDEFEMI KRNTSEI ISEEELREVLK KDEKSAFIGFEP GKIHLGHYLQIKKMIDLQ NAGFDI I ILLPDLHAYLNQK GELDEIRKIGDYNKKVFEAMGLKAKYVYGSEFQLDKDY TLNVYRLALKTTLKRARRSMELIAREDENPKVAEVIYP IMQVNDIHYLGVDVAVGGMEQRKIHMLARELLPKKVVC IHNPVLTGLDGEGKMSSSKGNFIAVDDSP EIRAKIKK AYCPAGVVEGNPIMEIAKYFLEYPLTIKRPEKFGGDLT VNSYEELES LFKNKELHPMDLKNVAEELIKILEPIRK RL
SEQ ID NO: 2 GalNAc- α -threonine aminoacyl-tRNA synthetase isolate-C8F amino acid sequence (derived from wild-type <i>Methanococcus jannaschii</i> tyrosyl tRNA-synthetase), having amino acid changes: Tyr32Gln Ala67Pro Gly163Cys Ala167Val	MDEFEMI KRNTSEI ISEEELREVLK KDEKSAQIGFEP GKIHLGHYLQIKKMIDLQ NAGFDI I ILLPDLHAYLNQK GELDEIRKIGDYNKKVFEAMGLKAKYVYGSEFQLDKDY TLNVYRLALKTTLKRARRSMELIAREDENPKVAEVIYP IMQVNDIHYLCVDVVVGGMEQRKIHMLARELLPKKVVC IHNPVLTGLDGEGKMSSSKGNFIAVDDSP EIRAKIKK AYCPAGVVEGNPIMEIAKYFLEYPLTIKRPEKFGGDLT VNSYEELES LFKNKELHPMDLKNVAEELIKILEPIRK RL
SEQ ID NO: 3 GalNAc- α -threonine aminoacyl-tRNA synthetase isolate-C10F amino acid sequence (derived from wild-type <i>Methanococcus jannaschii</i> tyrosyl tRNA-synthetase), having amino acid changes: Tyr32Ala Ala67Ser His70Pro Leu98Ile	MDEFEMI KRNTSEI ISEEELREVLK KDEKSAAGFEP GKIHLGHYLQIKKMIDLQ NAGFDI I ILLSDLPAYLNQK GELDEIRKIGDYNKKVFEAMGIKAKYVYGSEFQLDKDY TLNVYRLALKTTLKRARRSMELIAREDENPKVAEVIYP IMQVNDIHYLGVDVAVGGMEQRKIHMLARELLPKKVVC IHNPVLTGLDGEGKMSSSKGNFIAVDDSP EIRAKIKK AYCPAGVVEGNPIMEIAKYFLEYPLTIKRPEKFGGDLT VNSYEELES LFKNKELHPMDLKNVAEELIKILEPIRK RL
SEQ ID NO: 4 GalNAc- α -threonine aminoacyl-tRNA synthetase isolate-D10B amino acid sequence (derived from wild-type <i>Methanococcus jannaschii</i> tyrosyl tRNA-synthetase), having amino acid changes: Tyr32Leu Ala67Thr His70Lys Val149Ile Gln155Ser Asp158Val Ala167Val	MDEFEMI KRNTSEI ISEEELREVLK KDEKSALIGFEP GKIHLGHYLQIKKMIDLQ NAGFDI I ILLTDLKAYLNQK GELDEIRKIGDYNKKVFEAMGLKAKYVYGSEFQLDKDY TLNVYRLALKTTLKRARRSMELIAREDENPKVAEVIYP IMSVNVIIHYLGVDVVVGGMEQRKIHMLARELLPKKVVC IHNPVLTGLDGEGKMSSSKGNFIAVDDSP EIRAKIKK AYCPAGVVEGNPIMEIAKYFLEYPLTIKRPEKFGGDLT VNSYEELES LFKNKELHPMDLKNVAEELIKILEPIRK RL

TABLE 3-continued

Description	Sequences
SEQ ID NO: 5 Wild-type <i>Methanococcus jannaschii</i> tyrosyl-tRNA synthetase (MjTyrRS) amino acid sequence	MDEFEMI KRNTSEI ISEEELREVLKKDEKSAYTGFEPS GKIHLGHYLQIKKMIDLQNAGFDI IILLADLHAYLNQK GELDEIRKIGDYNKKVFEAMGLKAKYVYGSEFQLDKDY TLNVYRLALKTTLPARRSMELIAREDENPKVAEVIYP IMQVNDIHYLGVDVAVGGMEQRKIHMLARELLPKKVV IHNPVLTGLDGEKMSSSKGNFTAVDDSP EEI PAKIKK AYCPAGVVEGNPIMEIAKYFLEYPLTIKRPEKFGGDLT VNSYEELES LFKNKELHPMDLKNVAEELIKILEPIRK RL
SEQ ID NO: 6 GalNAc- α -threonine aminoacyl-tRNA synthetase isolate-AH1 nucleotide sequence	atggacgaatttgaaatgataaagagaaacacatctga aattatcagcgaggaagagttaagagagggttttaaaaa aagatgaaaaatctgctttatagggtttgaaccaagt ggtaaaatacatttagggcattatctccaaataaaaa gatgattgatttacaataatgctggatttgatataatta tatgttgacctgattacatgcctatttaaacagaaa ggagagttggatgagattagaaaaataggagattataa caaaaaagttttgaagcaatggggttaaggcaaaaat atgtttatggaagtgaattccagcttgataaggattat aactgaatgtctatagattggcttataaaactacctt aaaaagagcaagaaggagtatggaacttatagcaagag aggatgaaaatccaaagggtgctgaagttatctatcca ataatacaggttaataatgatattcattataggcgttga tgttgcaagtggagggatggagcagagaaaaatacaca tgttagcaagggagctttacaaaaaagggtgtttgt attcacaacctgtcttaacgggttggatggagaagg aaagatgagttcttcaaaaggaatttatagctgttg atgactctccagaagagattagggttaagataaagaaa gcatactgccagctggagtgttgaaggaaaatccaat aatggagatagctaaatacttcttgaatataccttaa ccataaaaaggccagaaaaatttgggtggagatttgaca gttaatagctatgaggagttagagagttatttaaaaa taaggaattgcatccaatggatttaaaaaatgctgtag ctgaagaacttataaagatttttagagccaattagaaag agatta
SEQ ID NO: 7 GalNAc- α -threonine aminoacyl-tRNA synthetase isolate-C8F nucleotide sequence	atggacgaatttgaaatgataaagagaaacacatctga aattatcagcgaggaagagttaagagagggttttaaaaa aagatgaaaaatctgctcagatagggtttgaaccaagt ggtaaaatacatttagggcattatctccaaataaaaa gatgattgatttacaataatgctggatttgatataatta tatgttgacctgattacatgcctatttaaacagaaa ggagagttggatgagattagaaaaataggagattataa caaaaaagttttgaagcaatggggttaaggcaaaaat atgtttatggaagtgaattccagcttgataaggattat aactgaatgtctatagattggcttataaaactacctt aaaaagagcaagaaggagtatggaacttatagcaagag aggatgaaaatccaaagggtgctgaagttatctatcca ataatacaggttaataatgatattcattatgatgcgttga tgttgctgtggagggatggagcagagaaaaatacaca tgttagcaagggagctttacaaaaaagggtgtttgt attcacaacctgtcttaacgggttggatggagaagg aaagatgagttcttcaaaaggaatttatagctgttg atgactctccagaagagattagggttaagataaagaaa gcatactgccagctggagtgttgaaggaaaatccaat aatggagatagctaaatacttcttgaatataccttaa ccataaaaaggccagaaaaatttgggtggagatttgaca gttaatagctatgaggagttagagagttatttaaaaa taaggaattgcatccaatggatttaaaaaatgctgtag ctgaagaacttataaagatttttagagccaattagaaag agatta
SEQ ID NO: 8 GalNAc- α -threonine aminoacyl-tRNA synthetase isolate-C10F nucleotide sequence	atggacgaatttgaaatgataaagagaaacacatctga aattatcagcgaggaagagttaagagagggttttaaaaa aagatgaaaagtctgctgcgatagggtttgaaccaagt ggtaaaatacatttagggcattatctccaaataaaaa gatgattgatttacaataatgctggatttgatataatta tatgttgagtgatttacctgcctatttaaacagaaa ggagagttggatgagattagaaaaataggagattataa caaaaaagttttgaagcaatggggttaaggcaaaaat atgtttatggaagtgaattccagcttgataaggattat

TABLE 3-continued

<u>EXAMPLES OF SEQUENCES</u>	
Description	Sequences
sequence (derived from wild-type <i>Methanococcus jannaschii</i> tyrosyl tRNA-synthetase)	TLNVYRLALKTTLKRARRSMELIAREDENPKVAEVIYP IMQVNCYHYRGVDVAVGGMEQRKIHMLARELLPKKVVC IHNPLVTGLDGEKMSSSKGNFIAVDDSPPEIRAKIKK AYCPAGVVEGNPIMEIAKYFLEYPLTIKRPEKFGGDLT VNSYEELSLFKNKELHPMDLKNVAEELIKILEPIRKL
SEQ ID NO: 12 GlcNAc- β -serine aminoacyl-tRNA synthetase isolate-S4-5 amino acid sequence (derived from wild-type <i>Methanococcus jannaschii</i> tyrosyl tRNA-synthetase)	MDEFEMIKRNTSEIISEEELREVLKKDEKSAGIGFEP GKIHLGHYLQIKKMIDLQAGFDIIILLADLHAYLNQK GELDEIRKIGDYNKKVFEAMGLKAKYVYGSFQLDKDY TLNVYRLALKTTLKRARRSMELIAREDENPKVAEVIYP IMQVNCMHYHGVDVAVGGMEQRKIHMLARELLPKKVVC IHNPLVTGLDGEKMSSSKGNFIAVDDSPPEIRAKIKK AYCPAGVVEGNPIMEIAKYFLEYPLTIKRPEKFGGDLT VNSYEELSLFKNKELHPMDLKNVAEELIKILEPIRKL
SEQ ID NO: 13 GlcNAc- β 3-serine aminoacyl-tRNA synthetase isolate-S1-5 amino acid sequence (derived from wild-type <i>Methanococcus jannaschii</i> tyrosyl tRNA-synthetase)	MDEFEMIKRNTSEIISEEELREVLKKDEKSAYIGFEP GKIHLGHYLQIKKMIDLQAGFDIIILLADLHAYLNQK GELDEIRKIGDYNKKVFEAMGLKAKYVYGS [C/S] FQL DKDYTLNVYRLALKTTLKRARRSMELIAREDENPKVAE VIYPIQVNHHDHYMGVDVAVGGMEQRKIHMLARELLPK KVVCIHNPLVTGLDGEKMSSSKGNFIAVDDSPPEIRA KIKKAYCPAGVVEGNPIMEIAKYFLEYPLTIKRPEKFG GDLTVNSYEELSLFKNKELHPMDLKNVAEELIKILE PIRKRL (note: Position 107 can be either a C or S)
SEQ ID NO: 14 GlcNAc- β -serine aminoacyl-tRNA synthetase isolate-S1-90 nucleotide sequence	atggacgaatttgaaatgataaagagaaacacatctga aattatcagcgaggaagagttaagagagggttttaaaaa aagatgaaaaatctgcttacatagggtttgaaccaagt ggtaaaatacatttagggcattatctccaaataaaaa gatgattgattacaaaatgctggatttgatataatta tattgttggctgattacacgcctatttaaacagaaa ggagagtggatgagattagaaaaataggagattataa caaaaaagttttgaagcaatggggttaaggcaaaaat atgttatggaagtcattccagcttgataaggattat acactgaatgtctatagattggcttataaaactacctt aaaaagagcaagaaggagatggaacttatagcaagag aggatgaaaatccaaagggtgctgaagttatctatcca ataatgcaggtaattgctatcattatagggcgcttga tgttgcagttggaggatggagcagagaaaaatcacaca tgtagcaagggagctttaccaaaaagggtgtttgt attcacaacctgtcttaacgggttggatggagaagg aaagatgagttcttcaaaaggaattttatagctgttg atgactctccagaagagattagggttaagataaagaaa gcatactgccagctggagttggtgaaggaaaatccaat aatggagatagctaaatacttcttgaatatcctttaa ccataaaaaggccagaaaaatttgggtggagatttgaca gttaatagctatgaggagttagagagttatttaaaaa taaggaattgcatccaatggatttaaaaaatgctgtag ctgaagaactataaagatttttagagccaattagaaag agattataa
SEQ ID NO: 15 GlcNAc- β -serine aminoacyl-tRNA synthetase isolate-S4-5 nucleotide sequence	atggacgaatttgaaatgataaagagaaacacatctga aattatcagcgaggaagagttaagagagggttttaaaaa aagatgaaaaatctgctggaatagggtttgaaccaagt ggtaaaatacatttagggcattatctccaaataaaaa gatgattgattacaaaatgctggatttgatataatta tattgttggctgattacacgcctatttaaacagaaa ggagagtggatgagattagaaaaataggagattataa caaaaaagttttgaagcaatggggttaaggcaaaaat atgttatggaagtgattccagcttgataaggattat acactgaatgtctatagattggcttataaaactacctt aaaaagagcaagaaggagatggaacttatagcaagag aggatgaaaatccaaagggtgctgaagttatctatcca ataatgcaggtaattgctatgctatcacggcgcttga tgttgcagttggaggatggagcagagaaaaatcacaca tgtagcaagggagctttaccaaaaagggtgtttgt attcacaacctgtcttaacgggttggatggagaagg aaagatgagttcttcaaaaggaattttatagctgttg

TABLE 3-continued

EXAMPLES OF SEQUENCES	
Description	Sequences
	atgactctccagaagagattagggctaagataaagaaa gcatactgccagctggagtgttgaaggaaatccaat aatggagatagctaaatacttcttgaatatcctttaa ccataaaaaggccagaaaaatttggaggagatttgaca gttaatagctatgaggagttagagagtttatttaaaaa taaggaattgcatccaatggatttaaaaaatgctgtag ctgaagaacttataaagattttagagccaattagaaag agattataa
SEQ ID NO: 16 GlcNAc- β -serine aminoacyl-tRNA synthetase isolate-S1-5 nucleotide sequence	atggacgaatttgaaatgataaagagaaacacatctga aattatcagcgaggaagagttaagagaggttttaaaaa aagatgaaaaatctgcttacatagggtttgaaccaagt ggtaaaatacatttagggcattatctccaaataaaaaa gatgattgatttacaaaatgctggatttgatataatta tattgttggctgatttacacgcctatttaaccagaaa ggagagttggatgagattagaaaaataggagattataa caaaaaagtttttgaagcaatgggggttaaggcaaaaat atgtttatggaagttcattccagcttgataaggattat acactgaatgtctatagattggctttaaaaactacctt aaaaagagcaagaaggagtatggaacttatagcaagag aggatgaaaaatccaaagggtgctgaagttatctatcca ataatgcaggttaatcatgatcattatagggcggtga tgttcagttggagggatggagcagagaaaaatacaca tgttagcaaggagctttaccaaaaagggtgtttgt attcacaacctgtcttaacgggttggatggagaagg aaagatgagttcttcaaaagggaatttatagctgttg atgactctccagaagagattagggctaagataaagaaa gcatactgccagctggagtgttgaaggaaatccaat aatggagatagctaaatacttcttgaatatcctttaa ccataaaaaggccagaaaaatttggaggagatttgaca gttaatagctatgaggagttagagagtttatttaaaaa taaggaattgcatccaatggatttaaaaaatgctgtag ctgaagaacttataaagattttagagccaattagaaag agattataa
SEQ ID NO: 17 mutant tyrosyl-tRNA _{CUA}	ccggcgguaguucagcagggcagaacggcggacucuaa auccgcaugggcugguucaaauccggcccggacc a

SEQUENCE LISTING

<160> NUMBER OF SEQ ID NOS: 19

<210> SEQ ID NO 1

<211> LENGTH: 306

<212> TYPE: PRT

<213> ORGANISM: Artificial

<220> FEATURE:

<223> OTHER INFORMATION: mutant tRNA synthetase

<400> SEQUENCE: 1

Met Asp Glu Phe Glu Met Ile Lys Arg Asn Thr Ser Glu Ile Ile Ser
1 5 10 15

Glu Glu Glu Leu Arg Glu Val Leu Lys Lys Asp Glu Lys Ser Ala Phe
20 25 30

Ile Gly Phe Glu Pro Ser Gly Lys Ile His Leu Gly His Tyr Leu Gln
35 40 45

Ile Lys Lys Met Ile Asp Leu Gln Asn Ala Gly Phe Asp Ile Ile Ile
50 55 60

Leu Leu Pro Asp Leu His Ala Tyr Leu Asn Gln Lys Gly Glu Leu Asp
65 70 75 80

-continued

Glu Ile Arg Lys Ile Gly Asp Tyr Asn Lys Lys Val Phe Glu Ala Met
 85 90 95
 Gly Leu Lys Ala Lys Tyr Val Tyr Gly Ser Glu Phe Gln Leu Asp Lys
 100 105 110
 Asp Tyr Thr Leu Asn Val Tyr Arg Leu Ala Leu Lys Thr Thr Leu Lys
 115 120 125
 Arg Ala Arg Arg Ser Met Glu Leu Ile Ala Arg Glu Asp Glu Asn Pro
 130 135 140
 Lys Val Ala Glu Val Ile Tyr Pro Ile Met Gln Val Asn Asp Ile His
 145 150 155 160
 Tyr Leu Gly Val Asp Val Ala Val Gly Gly Met Glu Gln Arg Lys Ile
 165 170 175
 His Met Leu Ala Arg Glu Leu Leu Pro Lys Lys Val Val Cys Ile His
 180 185 190
 Asn Pro Val Leu Thr Gly Leu Asp Gly Glu Gly Lys Met Ser Ser Ser
 195 200 205
 Lys Gly Asn Phe Ile Ala Val Asp Asp Ser Pro Glu Glu Ile Arg Ala
 210 215 220
 Lys Ile Lys Lys Ala Tyr Cys Pro Ala Gly Val Val Glu Gly Asn Pro
 225 230 235 240
 Ile Met Glu Ile Ala Lys Tyr Phe Leu Glu Tyr Pro Leu Thr Ile Lys
 245 250 255
 Arg Pro Glu Lys Phe Gly Gly Asp Leu Thr Val Asn Ser Tyr Glu Glu
 260 265 270
 Leu Glu Ser Leu Phe Lys Asn Lys Glu Leu His Pro Met Asp Leu Lys
 275 280 285
 Asn Ala Val Ala Glu Glu Leu Ile Lys Ile Leu Glu Pro Ile Arg Lys
 290 295 300
 Arg Leu
 305

<210> SEQ ID NO 2
 <211> LENGTH: 306
 <212> TYPE: PRT
 <213> ORGANISM: Artificial
 <220> FEATURE:
 <223> OTHER INFORMATION: mutant tRNA synthetase

<400> SEQUENCE: 2

Met Asp Glu Phe Glu Met Ile Lys Arg Asn Thr Ser Glu Ile Ile Ser
 1 5 10 15
 Glu Glu Glu Leu Arg Glu Val Leu Lys Lys Asp Glu Lys Ser Ala Gln
 20 25 30
 Ile Gly Phe Glu Pro Ser Gly Lys Ile His Leu Gly His Tyr Leu Gln
 35 40 45
 Ile Lys Lys Met Ile Asp Leu Gln Asn Ala Gly Phe Asp Ile Ile Ile
 50 55 60
 Leu Leu Pro Asp Leu His Ala Tyr Leu Asn Gln Lys Gly Glu Leu Asp
 65 70 75 80
 Glu Ile Arg Lys Ile Gly Asp Tyr Asn Lys Lys Val Phe Glu Ala Met
 85 90 95
 Gly Leu Lys Ala Lys Tyr Val Tyr Gly Ser Glu Phe Gln Leu Asp Lys
 100 105 110

-continued

Asp Tyr Thr Leu Asn Val Tyr Arg Leu Ala Leu Lys Thr Thr Leu Lys
 115 120 125
 Arg Ala Arg Arg Ser Met Glu Leu Ile Ala Arg Glu Asp Glu Asn Pro
 130 135 140
 Lys Val Ala Glu Val Ile Tyr Pro Ile Met Gln Val Asn Asp Ile His
 145 150 155 160
 Tyr Leu Cys Val Asp Val Val Val Gly Gly Met Glu Gln Arg Lys Ile
 165 170 175
 His Met Leu Ala Arg Glu Leu Leu Pro Lys Lys Val Val Cys Ile His
 180 185 190
 Asn Pro Val Leu Thr Gly Leu Asp Gly Glu Gly Lys Met Ser Ser Ser
 195 200 205
 Lys Gly Asn Phe Ile Ala Val Asp Asp Ser Pro Glu Glu Ile Arg Ala
 210 215 220
 Lys Ile Lys Lys Ala Tyr Cys Pro Ala Gly Val Val Glu Gly Asn Pro
 225 230 235 240
 Ile Met Glu Ile Ala Lys Tyr Phe Leu Glu Tyr Pro Leu Thr Ile Lys
 245 250 255
 Arg Pro Glu Lys Phe Gly Gly Asp Leu Thr Val Asn Ser Tyr Glu Glu
 260 265 270
 Leu Glu Ser Leu Phe Lys Asn Lys Glu Leu His Pro Met Asp Leu Lys
 275 280 285
 Asn Ala Val Ala Glu Glu Leu Ile Lys Ile Leu Glu Pro Ile Arg Lys
 290 295 300
 Arg Leu
 305

<210> SEQ ID NO 3
 <211> LENGTH: 306
 <212> TYPE: PRT
 <213> ORGANISM: Artificial
 <220> FEATURE:
 <223> OTHER INFORMATION: mutant tRNA synthetase

<400> SEQUENCE: 3

Met Asp Glu Phe Glu Met Ile Lys Arg Asn Thr Ser Glu Ile Ile Ser
 1 5 10 15
 Glu Glu Glu Leu Arg Glu Val Leu Lys Lys Asp Glu Lys Ser Ala Ala
 20 25 30
 Ile Gly Phe Glu Pro Ser Gly Lys Ile His Leu Gly His Tyr Leu Gln
 35 40 45
 Ile Lys Lys Met Ile Asp Leu Gln Asn Ala Gly Phe Asp Ile Ile Ile
 50 55 60
 Leu Leu Ser Asp Leu Pro Ala Tyr Leu Asn Gln Lys Gly Glu Leu Asp
 65 70 75 80
 Glu Ile Arg Lys Ile Gly Asp Tyr Asn Lys Lys Val Phe Glu Ala Met
 85 90 95
 Gly Ile Lys Ala Lys Tyr Val Tyr Gly Ser Glu Phe Gln Leu Asp Lys
 100 105 110
 Asp Tyr Thr Leu Asn Val Tyr Arg Leu Ala Leu Lys Thr Thr Leu Lys
 115 120 125
 Arg Ala Arg Arg Ser Met Glu Leu Ile Ala Arg Glu Asp Glu Asn Pro
 130 135 140

-continued

Lys Val Ala Glu Val Ile Tyr Pro Ile Met Gln Val Asn Asp Ile His
145 150 155 160

Tyr Leu Gly Val Asp Val Ala Val Gly Gly Met Glu Gln Arg Lys Ile
165 170 175

His Met Leu Ala Arg Glu Leu Leu Pro Lys Lys Val Val Cys Ile His
180 185 190

Asn Pro Val Leu Thr Gly Leu Asp Gly Glu Gly Lys Met Ser Ser Ser
195 200 205

Lys Gly Asn Phe Ile Ala Val Asp Asp Ser Pro Glu Glu Ile Arg Ala
210 215 220

Lys Ile Lys Lys Ala Tyr Cys Pro Ala Gly Val Val Glu Gly Asn Pro
225 230 235 240

Ile Met Glu Ile Ala Lys Tyr Phe Leu Glu Tyr Pro Leu Thr Ile Lys
245 250 255

Arg Pro Glu Lys Phe Gly Gly Asp Leu Thr Val Asn Ser Tyr Glu Glu
260 265 270

Leu Glu Ser Leu Phe Lys Asn Lys Glu Leu His Pro Met Asp Leu Lys
275 280 285

Asn Ala Val Ala Glu Glu Leu Ile Lys Ile Leu Glu Pro Ile Arg Lys
290 295 300

Arg Leu
305

<210> SEQ ID NO 4
 <211> LENGTH: 306
 <212> TYPE: PRT
 <213> ORGANISM: Artificial
 <220> FEATURE:
 <223> OTHER INFORMATION: mutant tRNA synthetase

<400> SEQUENCE: 4

Met Asp Glu Phe Glu Met Ile Lys Arg Asn Thr Ser Glu Ile Ile Ser
1 5 10 15

Glu Glu Glu Leu Arg Glu Val Leu Lys Lys Asp Glu Lys Ser Ala Leu
20 25 30

Ile Gly Phe Glu Pro Ser Gly Lys Ile His Leu Gly His Tyr Leu Gln
35 40 45

Ile Lys Lys Met Ile Asp Leu Gln Asn Ala Gly Phe Asp Ile Ile Ile
50 55 60

Leu Leu Thr Asp Leu Lys Ala Tyr Leu Asn Gln Lys Gly Glu Leu Asp
65 70 75 80

Glu Ile Arg Lys Ile Gly Asp Tyr Asn Lys Lys Val Phe Glu Ala Met
85 90 95

Gly Leu Lys Ala Lys Tyr Val Tyr Gly Ser Glu Phe Gln Leu Asp Lys
100 105 110

Asp Tyr Thr Leu Asn Val Tyr Arg Leu Ala Leu Lys Thr Thr Leu Lys
115 120 125

Arg Ala Arg Arg Ser Met Glu Leu Ile Ala Arg Glu Asp Glu Asn Pro
130 135 140

Lys Val Ala Glu Ile Ile Tyr Pro Ile Met Ser Val Asn Val Ile His
145 150 155 160

Tyr Leu Gly Val Asp Val Val Val Gly Gly Met Glu Gln Arg Lys Ile
165 170 175

-continued

His Met Leu Ala Arg Glu Leu Leu Pro Lys Lys Val Val Cys Ile His
 180 185 190
 Asn Pro Val Leu Thr Gly Leu Asp Gly Glu Gly Lys Met Ser Ser Ser
 195 200 205
 Lys Gly Asn Phe Ile Ala Val Asp Asp Ser Pro Glu Glu Ile Arg Ala
 210 215 220
 Lys Ile Lys Lys Ala Tyr Cys Pro Ala Gly Val Val Glu Gly Asn Pro
 225 230 235 240
 Ile Met Glu Ile Ala Lys Tyr Phe Leu Glu Tyr Pro Leu Thr Ile Lys
 245 250 255
 Arg Pro Glu Lys Phe Gly Gly Asp Leu Thr Val Asn Ser Tyr Glu Glu
 260 265 270
 Leu Glu Ser Leu Phe Lys Asn Lys Glu Leu His Pro Met Asp Leu Lys
 275 280 285
 Asn Ala Val Ala Glu Glu Leu Ile Lys Ile Leu Glu Pro Ile Arg Lys
 290 295 300
 Arg Leu
 305

<210> SEQ ID NO 5
 <211> LENGTH: 306
 <212> TYPE: PRT
 <213> ORGANISM: Methanococcus jannaschii

<400> SEQUENCE: 5

Met Asp Glu Phe Glu Met Ile Lys Arg Asn Thr Ser Glu Ile Ile Ser
 1 5 10 15
 Glu Glu Glu Leu Arg Glu Val Leu Lys Lys Asp Glu Lys Ser Ala Tyr
 20 25 30
 Ile Gly Phe Glu Pro Ser Gly Lys Ile His Leu Gly His Tyr Leu Gln
 35 40 45
 Ile Lys Lys Met Ile Asp Leu Gln Asn Ala Gly Phe Asp Ile Ile Ile
 50 55 60
 Leu Leu Ala Asp Leu His Ala Tyr Leu Asn Gln Lys Gly Glu Leu Asp
 65 70 75 80
 Glu Ile Arg Lys Ile Gly Asp Tyr Asn Lys Lys Val Phe Glu Ala Met
 85 90 95
 Gly Leu Lys Ala Lys Tyr Val Tyr Gly Ser Glu Phe Gln Leu Asp Lys
 100 105 110
 Asp Tyr Thr Leu Asn Val Tyr Arg Leu Ala Leu Lys Thr Thr Leu Lys
 115 120 125
 Arg Ala Arg Arg Ser Met Glu Leu Ile Ala Arg Glu Asp Glu Asn Pro
 130 135 140
 Lys Val Ala Glu Val Ile Tyr Pro Ile Met Gln Val Asn Asp Ile His
 145 150 155 160
 Tyr Leu Gly Val Asp Val Ala Val Gly Gly Met Glu Gln Arg Lys Ile
 165 170 175
 His Met Leu Ala Arg Glu Leu Leu Pro Lys Lys Val Val Cys Ile His
 180 185 190
 Asn Pro Val Leu Thr Gly Leu Asp Gly Glu Gly Lys Met Ser Ser Ser
 195 200 205
 Lys Gly Asn Phe Ile Ala Val Asp Asp Ser Pro Glu Glu Ile Arg Ala

-continued

```

atacatttag ggcattatct ccaaataaaa aagatgattg atttcaaaa tgctggattt 180
gatataatta tattgttgc tgatttacat gcctatttaa accagaaagg agagttggat 240
gagattagaa aaataggaga ttataacaaa aaagtttttg aagcaatggg gttaaaggca 300
aaatagtgtt atggaagtga attccagctt gataaggatt atacactgaa tgtctataga 360
ttggctttta aaactacctt aaaaagagca agaaggagta tggaacttat agcaagagag 420
gatgaaaatc caaaggttgc tgaagttatc tatccaataa tgcaggtaa tgatattcat 480
tatttatgcg ttgatgttgc tgttgaggag atggagcaga gaaaaataca catgtagca 540
aggagcttt taccaaaaaa ggttgtttgt attcacaacc ctgtctaac gggtttgat 600
ggagaaggaa agatgagttc ttcaaaaggg aattttatag ctggtgatga ctctccagaa 660
gagattaggg ctaagataaa gaaagcatac tgcccagctg gagttgttga aggaaatcca 720
ataatggaga tagctaaata cttccttgaa tatcctttaa ccataaaaag gccagaaaaa 780
tttggaggag atttgacagt taatagctat gaggagttag agagtttatt taaaaataag 840
gaattgcatc caatggattt aaaaaatgct gtagctgaag aacttataaa gattttagag 900
ccaattagaa agagatta 918

```

```

<210> SEQ ID NO 8
<211> LENGTH: 918
<212> TYPE: DNA
<213> ORGANISM: Artificial
<220> FEATURE:
<223> OTHER INFORMATION: mutant tRNA synthetase

```

```

<400> SEQUENCE: 8

```

```

atggacgaat ttgaaatgat aaagagaaac acatctgaaa ttatcagcga ggaagagtta 60
agagaggttt taaaaaaga tgaaaagtct gctgcgatag gttttgaacc aagtggtaaa 120
atacatttag ggcattatct ccaaataaaa aagatgattg atttcaaaa tgctggattt 180
gatataatta tattgttgag tgatttacct gcctatttaa accagaaagg agagttggat 240
gagattagaa aaataggaga ttataacaaa aaagtttttg aagcaatggg gataaaggca 300
aaatagtgtt atggaagtga attccagctt gataaggatt atacactgaa tgtctataga 360
ttggctttta aaactacctt aaaaagagca agaaggagta tggaacttat agcaagagag 420
gatgaaaatc caaaggttgc tgaagttatc tatccaataa tgcaggtaa tgatattcat 480
tatttaggag ttgatgttgc agttggaggg atggagcaga gaaaaataca catgtagca 540
aggagcttt taccaaaaaa ggttgtttgt attcacaacc ctgtctaac gggtttgat 600
ggagaaggaa agatgagttc ttcaaaaggg aattttatag ctggtgatga ctctccagaa 660
gagattaggg ctaagataaa gaaagcatac tgcccagctg gagttgttga aggaaatcca 720
ataatggaga tagctaaata cttccttgaa tatcctttaa ccataaaaag gccagaaaaa 780
tttggaggag atttgacagt taatagctat gaggagttag agagtttatt taaaaataag 840
gaattgcatc caatggattt aaaaaatgct gtagctgaag aacttataaa gattttagag 900
ccaattagaa agagatta 918

```

```

<210> SEQ ID NO 9
<211> LENGTH: 918
<212> TYPE: DNA
<213> ORGANISM: Artificial
<220> FEATURE:

```

-continued

<223> OTHER INFORMATION: mutant tRNA synthetase

<400> SEQUENCE: 9

atggacgaat ttgaaatgat aaagagaaac acatctgaaa ttatcagcga ggaagagtta 60
agagagggtt taaaaaaaga tgaaaaatct gctcttatag gttttgaacc aagtggtaaa 120
atacatttag ggcattatct ccaaataaaa aagatgattg atttacaata tgctggattt 180
gatataatta tattgttgac ggatttaaag gcctatttaa accagaaagg agagttggat 240
gagattagaa aaataggaga ttataacaaa aaagtttttg aagcaatggg gttaaaggca 300
aaatatgttt atggaagtga attccagctt gataaggatt atacactgaa tgtctataga 360
ttggctttta aaactacctt aaaaagagca agaaggagta tggaacttat agcaagagag 420
gatgaaaatc caaaggttgc tgaattatc tatccaataa tgagtgttaa tgtgattcat 480
tatttaggcg ttgatgttgt tgttgaggag atggagcaga gaaaaataca catgttagca 540
aggagacttt taccaaaaaa ggttggttgt attcacaacc ctgtctaac gggtttgat 600
ggagaaggaa agatgagttc ttcaaaaggg aattttatag ctggtgatga ctctccagaa 660
gagattaggg ctaagataaa gaaagcatac tgcccagctg gagttgttga aggaaatcca 720
ataatggaga tagctaaata cttccttgaa tacccttaa ccataaaaag gccagaaaaa 780
tttggaggag atttgacagt taatagctat gaggagttag agagtttatt taaaaataag 840
gaattgcatc caatggattt aaaaaatgct gtagctgaag aacttataaa gatttttagag 900
ccaattagaa agagatta 918

<210> SEQ ID NO 10

<211> LENGTH: 918

<212> TYPE: DNA

<213> ORGANISM: Methanococcus jannaschii

<400> SEQUENCE: 10

atggacgaat ttgaaatgat aaagagaaac acatctgaaa ttatcagcga ggaagagtta 60
agagagggtt taaaaaaaga tgaaaaatct gcttacaatag gttttgaacc aagtggtaaa 120
atacatttag ggcattatct ccaaataaaa aagatgattg atttacaata tgctggattt 180
gatataatta tattgttggc tgatttacac gcctatttaa accagaaagg agagttggat 240
gagattagaa aaataggaga ttataacaaa aaagtttttg aagcaatggg gttaaaggca 300
aaatatgttt atggaagtga attccagctt gataaggatt atacactgaa tgtctataga 360
ttggctttta aaactacctt aaaaagagca agaaggagta tggaacttat agcaagagag 420
gatgaaaatc caaaggttgc tgaagttatc tatccaataa tgcaggtaa tgatattcat 480
tatttaggcg ttgatgttgc agttggagg atggagcaga gaaaaataca catgttagca 540
aggagacttt taccaaaaaa ggttggttgt attcacaacc ctgtctaac gggtttgat 600
ggagaaggaa agatgagttc ttcaaaaggg aattttatag ctggtgatga ctctccagaa 660
gagattaggg ctaagataaa gaaagcatac tgcccagctg gagttgttga aggaaatcca 720
ataatggaga tagctaaata cttccttgaa tacccttaa ccataaaaag gccagaaaaa 780
tttggaggag atttgacagt taatagctat gaggagttag agagtttatt taaaaataag 840
gaattgcatc caatggattt aaaaaatgct gtagctgaag aacttataaa gatttttagag 900
ccaattagaa agagatta 918

-continued

```

<210> SEQ ID NO 11
<211> LENGTH: 306
<212> TYPE: PRT
<213> ORGANISM: Artificial
<220> FEATURE:
<223> OTHER INFORMATION: mutant tRNA synthetase

<400> SEQUENCE: 11

Met Asp Glu Phe Glu Met Ile Lys Arg Asn Thr Ser Glu Ile Ile Ser
1          5          10          15
Glu Glu Glu Leu Arg Glu Val Leu Lys Lys Asp Glu Lys Ser Ala Tyr
20          25          30
Ile Gly Phe Glu Pro Ser Gly Lys Ile His Leu Gly His Tyr Leu Gln
35          40          45
Ile Lys Lys Met Ile Asp Leu Gln Asn Ala Gly Phe Asp Ile Ile Ile
50          55          60
Leu Leu Ala Asp Leu His Ala Tyr Leu Asn Gln Lys Gly Glu Leu Asp
65          70          75          80
Glu Ile Arg Lys Ile Gly Asp Tyr Asn Lys Lys Val Phe Glu Ala Met
85          90          95
Gly Leu Lys Ala Lys Tyr Val Tyr Gly Ser Pro Phe Gln Leu Asp Lys
100         105         110
Asp Tyr Thr Leu Asn Val Tyr Arg Leu Ala Leu Lys Thr Thr Leu Lys
115         120         125
Arg Ala Arg Arg Ser Met Glu Leu Ile Ala Arg Glu Asp Glu Asn Pro
130         135         140
Lys Val Ala Glu Val Ile Tyr Pro Ile Met Gln Val Asn Cys Tyr His
145         150         155         160
Tyr Arg Gly Val Asp Val Ala Val Gly Gly Met Glu Gln Arg Lys Ile
165         170         175
His Met Leu Ala Arg Glu Leu Leu Pro Lys Lys Val Val Cys Ile His
180         185         190
Asn Pro Val Leu Thr Gly Leu Asp Gly Glu Gly Lys Met Ser Ser Ser
195         200         205
Lys Gly Asn Phe Ile Ala Val Asp Asp Ser Pro Glu Glu Ile Arg Ala
210         215         220
Lys Ile Lys Lys Ala Tyr Cys Pro Ala Gly Val Val Glu Gly Asn Pro
225         230         235         240
Ile Met Glu Ile Ala Lys Tyr Phe Leu Glu Tyr Pro Leu Thr Ile Lys
245         250         255
Arg Pro Glu Lys Phe Gly Gly Asp Leu Thr Val Asn Ser Tyr Glu Glu
260         265         270
Leu Glu Ser Leu Phe Lys Asn Lys Glu Leu His Pro Met Asp Leu Lys
275         280         285
Asn Ala Val Ala Glu Glu Leu Ile Lys Ile Leu Glu Pro Ile Arg Lys
290         295         300

Arg Leu
305

```

```

<210> SEQ ID NO 12
<211> LENGTH: 306
<212> TYPE: PRT
<213> ORGANISM: Artificial
<220> FEATURE:

```

-continued

<223> OTHER INFORMATION: mutant tRNA synthetase

<400> SEQUENCE: 12

Met Asp Glu Phe Glu Met Ile Lys Arg Asn Thr Ser Glu Ile Ile Ser
 1 5 10 15

Glu Glu Glu Leu Arg Glu Val Leu Lys Lys Asp Glu Lys Ser Ala Gly
 20 25 30

Ile Gly Phe Glu Pro Ser Gly Lys Ile His Leu Gly His Tyr Leu Gln
 35 40 45

Ile Lys Lys Met Ile Asp Leu Gln Asn Ala Gly Phe Asp Ile Ile Ile
 50 55 60

Leu Leu Ala Asp Leu His Ala Tyr Leu Asn Gln Lys Gly Glu Leu Asp
 65 70 75 80

Glu Ile Arg Lys Ile Gly Asp Tyr Asn Lys Lys Val Phe Glu Ala Met
 85 90 95

Gly Leu Lys Ala Lys Tyr Val Tyr Gly Ser Gly Phe Gln Leu Asp Lys
 100 105 110

Asp Tyr Thr Leu Asn Val Tyr Arg Leu Ala Leu Lys Thr Thr Leu Lys
 115 120 125

Arg Ala Arg Arg Ser Met Glu Leu Ile Ala Arg Glu Asp Glu Asn Pro
 130 135 140

Lys Val Ala Glu Val Ile Tyr Pro Ile Met Gln Val Asn Cys Met His
 145 150 155 160

Tyr His Gly Val Asp Val Ala Val Gly Gly Met Glu Gln Arg Lys Ile
 165 170 175

His Met Leu Ala Arg Glu Leu Leu Pro Lys Lys Val Val Cys Ile His
 180 185 190

Asn Pro Val Leu Thr Gly Leu Asp Gly Glu Gly Lys Met Ser Ser Ser
 195 200 205

Lys Gly Asn Phe Ile Ala Val Asp Asp Ser Pro Glu Glu Ile Arg Ala
 210 215 220

Lys Ile Lys Lys Ala Tyr Cys Pro Ala Gly Val Val Glu Gly Asn Pro
 225 230 235 240

Ile Met Glu Ile Ala Lys Tyr Phe Leu Glu Tyr Pro Leu Thr Ile Lys
 245 250 255

Arg Pro Glu Lys Phe Gly Gly Asp Leu Thr Val Asn Ser Tyr Glu Glu
 260 265 270

Leu Glu Ser Leu Phe Lys Asn Lys Glu Leu His Pro Met Asp Leu Lys
 275 280 285

Asn Ala Val Ala Glu Glu Leu Ile Lys Ile Leu Glu Pro Ile Arg Lys
 290 295 300

Arg Leu
 305

<210> SEQ ID NO 13

<211> LENGTH: 306

<212> TYPE: PRT

<213> ORGANISM: Artificial

<220> FEATURE:

<223> OTHER INFORMATION: mutant tRNA synthetase

<220> FEATURE:

<221> NAME/KEY: MISC_FEATURE

<222> LOCATION: (107)..(107)

<223> OTHER INFORMATION: X is C or S

-continued

<400> SEQUENCE: 13

Met Asp Glu Phe Glu Met Ile Lys Arg Asn Thr Ser Glu Ile Ile Ser
 1 5 10 15
 Glu Glu Glu Leu Arg Glu Val Leu Lys Lys Asp Glu Lys Ser Ala Tyr
 20 25 30
 Ile Gly Phe Glu Pro Ser Gly Lys Ile His Leu Gly His Tyr Leu Gln
 35 40 45
 Ile Lys Lys Met Ile Asp Leu Gln Asn Ala Gly Phe Asp Ile Ile Ile
 50 55 60
 Leu Leu Ala Asp Leu His Ala Tyr Leu Asn Gln Lys Gly Glu Leu Asp
 65 70 75 80
 Glu Ile Arg Lys Ile Gly Asp Tyr Asn Lys Lys Val Phe Glu Ala Met
 85 90 95
 Gly Leu Lys Ala Lys Tyr Val Tyr Gly Ser Xaa Phe Gln Leu Asp Lys
 100 105 110
 Asp Tyr Thr Leu Asn Val Tyr Arg Leu Ala Leu Lys Thr Thr Leu Lys
 115 120 125
 Arg Ala Arg Arg Ser Met Glu Leu Ile Ala Arg Glu Asp Glu Asn Pro
 130 135 140
 Lys Val Ala Glu Val Ile Tyr Pro Ile Met Gln Val Asn His Asp His
 145 150 155 160
 Tyr Met Gly Val Asp Val Ala Val Gly Gly Met Glu Gln Arg Lys Ile
 165 170 175
 His Met Leu Ala Arg Glu Leu Leu Pro Lys Lys Val Val Cys Ile His
 180 185 190
 Asn Pro Val Leu Thr Gly Leu Asp Gly Glu Gly Lys Met Ser Ser Ser
 195 200 205
 Lys Gly Asn Phe Ile Ala Val Asp Asp Ser Pro Glu Glu Ile Arg Ala
 210 215 220
 Lys Ile Lys Lys Ala Tyr Cys Pro Ala Gly Val Val Glu Gly Asn Pro
 225 230 235 240
 Ile Met Glu Ile Ala Lys Tyr Phe Leu Glu Tyr Pro Leu Thr Ile Lys
 245 250 255
 Arg Pro Glu Lys Phe Gly Gly Asp Leu Thr Val Asn Ser Tyr Glu Glu
 260 265 270
 Leu Glu Ser Leu Phe Lys Asn Lys Glu Leu His Pro Met Asp Leu Lys
 275 280 285
 Asn Ala Val Ala Glu Glu Leu Ile Lys Ile Leu Glu Pro Ile Arg Lys
 290 295 300
 Arg Leu
 305

<210> SEQ ID NO 14

<211> LENGTH: 921

<212> TYPE: DNA

<213> ORGANISM: Artificial

<220> FEATURE:

<223> OTHER INFORMATION: mutant tRNA synthetase

<400> SEQUENCE: 14

atggacgaat ttgaaatgat aaagagaaac acatctgaaa ttatcagcga ggaagagtta 60
 agagaggttt taaaaaaga tgaaaaatct gcttacatag gttttgaacc aagtggtaaa 120

-continued

```

atacatttag ggcattatct ccaaataaaa aagatgattg atttcaaaa tgctggattt 180
gatataatta tattgttggc tgatttacac gcctatntaa accagaaagg agagttggat 240
gagattagaa aaataggaga ttataacaaa aaagtttttg aagcaatggg gttaaaggca 300
aaatatgttt atggaagtcc attccagctt gataaggatt atacactgaa tgtctataga 360
ttggctntaa aaactacctt aaaaagagca agaaggagta tggaacttat agcaagagag 420
gatgaaaatc caaaggttgc tgaagttatc tatccaataa tgcaggntaa ttgctatcat 480
tataggggcg ttgatgttgc agttggaggg atggagcaga gaaaaataca catgnttagca 540
agggagcttt taccaaaaaa ggttgnttgt attcacaacc ctgtcttaac gggnttggat 600
ggagaaggaa agatgagttc ttcaaaaggg aatnttatag ctgntgatga ctctccagaa 660
gagattaggg ctaagataaa gaaagcatac tgcccagctg gagntgntga aggaaatcca 720
ataatggaga tagctaaata cttccttgaa tatcctntaa ccataaaaag gccagaaaaa 780
tttggntgag atttgacagt taatagctat gaggagntag agagnttatt taaaaataag 840
gaattgcatc caatggattt aaaaaatgct gtagctgaag aactntaaa gatnttagag 900
ccaattagaa agagattata a 921

```

```

<210> SEQ ID NO 15
<211> LENGTH: 921
<212> TYPE: DNA
<213> ORGANISM: Artificial
<220> FEATURE:
<223> OTHER INFORMATION: mutant tRNA synthetase

```

```

<400> SEQUENCE: 15

```

```

atggacgaat ttgaaatgat aaagagaaac acatctgaaa ttatcagcga ggaagagnta 60
agagagnttt taaaaaaaga tgaaaaatct gctggaatag gntttgaacc aagtggntaa 120
atacatttag ggcattatct ccaaataaaa aagatgattg atttcaaaa tgctggattt 180
gatataatta tattgttggc tgatttacac gcctatntaa accagaaagg agagttggat 240
gagattagaa aaataggaga ttataacaaa aaagtttttg aagcaatggg gttaaaggca 300
aaatatgttt atggaagtgg attccagctt gataaggatt atacactgaa tgtctataga 360
ttggctntaa aaactacctt aaaaagagca agaaggagta tggaacttat agcaagagag 420
gatgaaaatc caaaggttgc tgaagttatc tatccaataa tgcaggntaa ttgntatcat 480
tatcacggcg ttgatgttgc agttggaggg atggagcaga gaaaaataca catgnttagca 540
agggagcttt taccaaaaaa ggttgnttgt attcacaacc ctgtcttaac gggnttggat 600
ggagaaggaa agatgagttc ttcaaaaggg aatnttatag ctgntgatga ctctccagaa 660
gagattaggg ctaagataaa gaaagcatac tgcccagctg gagntgntga aggaaatcca 720
ataatggaga tagctaaata cttccttgaa tatcctntaa ccataaaaag gccagaaaaa 780
tttggntgag atttgacagt taatagctat gaggagntag agagnttatt taaaaataag 840
gaattgcatc caatggattt aaaaaatgct gtagctgaag aactntaaa gatnttagag 900
ccaattagaa agagattata a 921

```

```

<210> SEQ ID NO 16
<211> LENGTH: 921
<212> TYPE: DNA
<213> ORGANISM: Artificial
<220> FEATURE:

```

-continued

<223> OTHER INFORMATION: mutant tRNA synthetase

<400> SEQUENCE: 16

atggacgaat ttgaaatgat aaagagaaac acatctgaaa ttatcagcga ggaagagtta 60
agagaggttt taaaaaaga tgaaaaatct gttacatag gttttgaacc aagtggtaaa 120
atacatttag ggcattatct ccaaataaaa aagatgattg atttcaaaa tgctggattt 180
gatataatta tattgttggc tgatttacac gcctatttaa accagaaagg agagttggat 240
gagattagaa aaataggaga ttataacaaa aaagtttttg aagcaatggg gttaaaggca 300
aaatatgttt atggaagttc attccagctt gataaggatt atacactgaa tgtctataga 360
ttggctttaa aaactacctt aaaaagagca agaaggagta tggaacttat agcaagagag 420
gatgaaaatc caaaggttgc tgaagttatc tatccaataa tgcaggtaa tcatgatcat 480
tatatgggcg ttgatgttgc agttggaggg atggagcaga gaaaaataca catgtagca 540
agggagcttt taccaaaaaa ggttgtttgt attcacaacc ctgtctaac gggtttgat 600
ggagaaggaa agatgagttc ttcaaaaggg aattttatag ctgtagatga ctctccagaa 660
gagattaggg ctaagataaa gaaagcatac tgcccagctg gagttgttga aggaaatcca 720
ataatggaga tagctaaata cttccttgaa tatcctttaa ccataaaaag gccagaaaaa 780
tttggtagag atttgacagt taatagctat gaggagttag agagtttatt taaaaataag 840
gaattgcac caatggattt aaaaaatgct gtagctgaag aactataaa gatttttagag 900
ccaattagaa agagattata a 921

<210> SEQ ID NO 17

<211> LENGTH: 77

<212> TYPE: RNA

<213> ORGANISM: Artificial

<220> FEATURE:

<223> OTHER INFORMATION: mutant tRNA

<400> SEQUENCE: 17

ccggcgguag uucagcaggg cagaacggcg gacucuaaa cgcgauggcg cugguucaaa 60
uccggcccgc cggacca 77

<210> SEQ ID NO 18

<211> LENGTH: 4

<212> TYPE: PRT

<213> ORGANISM: Artificial

<220> FEATURE:

<223> OTHER INFORMATION: exemplary polypeptide product

<220> FEATURE:

<221> NAME/KEY: MISC_FEATURE

<222> LOCATION: (3)..(3)

<223> OTHER INFORMATION: X is GalNAc-alpha-threonine

<400> SEQUENCE: 18

Val Leu Xaa Glu
1

<210> SEQ ID NO 19

<211> LENGTH: 18

<212> TYPE: RNA

<213> ORGANISM: Artificial

-continued

<220> FEATURE:

<223> OTHER INFORMATION: exemplary mRNA

<400> SEQUENCE: 19

augguucugu aggaaggu

18

1 to 22. (canceled)

23. A translation system comprising:

- (a) an unnatural amino acid comprising an N-acetylgalactosamine moiety;
- (b) an orthogonal aminoacyl-tRNA synthetase (O—RS); and
- (c) an orthogonal tRNA (O-tRNA);

wherein said O—RS comprises an amino acid sequence that is at least 90% identical to SEQ ID NO: 5.

24. The translation system of claim 23, wherein said unnatural amino acid is selected from the group consisting of: an N-acetylgalactosamine- α -threonine, a triacetyl-N-acetylgalactosamine- α -threonine, an N-acetylgalactosamine- α -serine, and a triacetyl-N-acetylgalactosamine- α -serine.

25. The translation system of claim 23, wherein said O—RS is derived from a wild-type *Methanococcus jannaschii* tyrosyl-tRNA synthetase.

26. The translation system of claim 23, wherein said O—RS comprises an amino acid sequence selected from the amino acids sequences set forth in SEQ ID NOS: 1, 2, 3, or 4.

27. The translation system of claim 23, wherein said O-tRNA is an amber suppressor tRNA.

28. The translation system of claim 23, further comprising a nucleic acid encoding a protein of interest, said nucleic acid comprising at least one selector codon, wherein said selector codon is recognized by said O-tRNA.

29. The translation system of claim 23, wherein said translation system comprises a host cell wherein said host cell comprises said unnatural amino acid, said O—RS and said O-tRNA.

30. The translation system of claim 29, wherein said host cell is an *E. coli* cell.

31. The translation system of claim 29, wherein said host cell comprises a polynucleotide encoding said O—RS.

32. The translation system of claim 31, wherein said polynucleotide comprises a nucleotide sequence set forth in SEQ ID NOS: 6, 7, 8 or 9.

33. The translation system of claim 29, wherein said host cell comprises a polynucleotide encoding said O-tRNA.

* * * * *