



US 20080237443A1

(19) **United States**

(12) **Patent Application Publication**
Oliver et al.

(10) **Pub. No.: US 2008/0237443 A1**

(43) **Pub. Date: Oct. 2, 2008**

(54) **MICROELECTRONIC IMAGERS WITH CURVED IMAGE SENSORS AND METHODS FOR MANUFACTURING MICROELECTRONIC IMAGERS**

Publication Classification

(51) **Int. Cl.**
G01J 1/20 (2006.01)

(76) **Inventors:** **Steven D. Oliver**, Boise, ID (US);
Jin Li, Boise, ID (US); **Ulrich C. Boettiger**, Boise, ID (US)

(52) **U.S. Cl.** **250/200**

Correspondence Address:
DICKSTEIN SHAPIRO LLP
1825 EYE STREET NW
Washington, DC 20006-5403 (US)

(57) **ABSTRACT**

(21) **Appl. No.: 12/155,645**

Microelectronic imagers with curved image sensors and methods for manufacturing curved image sensors. In one embodiment, a microelectronic imager device comprises an imager die having a substrate, a curved microelectronic image sensor having a face with a convex and/or concave portion at one side of the substrate, and integrated circuitry in the substrate operatively coupled to the image sensor. The imager die can further include external contacts electrically coupled to the integrated circuitry and a cover over the curved image sensor.

(22) **Filed: Jun. 6, 2008**

Related U.S. Application Data

(62) Division of application No. 11/488,848, filed on Jul. 19, 2006, which is a division of application No. 10/922,177, filed on Aug. 19, 2004, now Pat. No. 7,397,066.

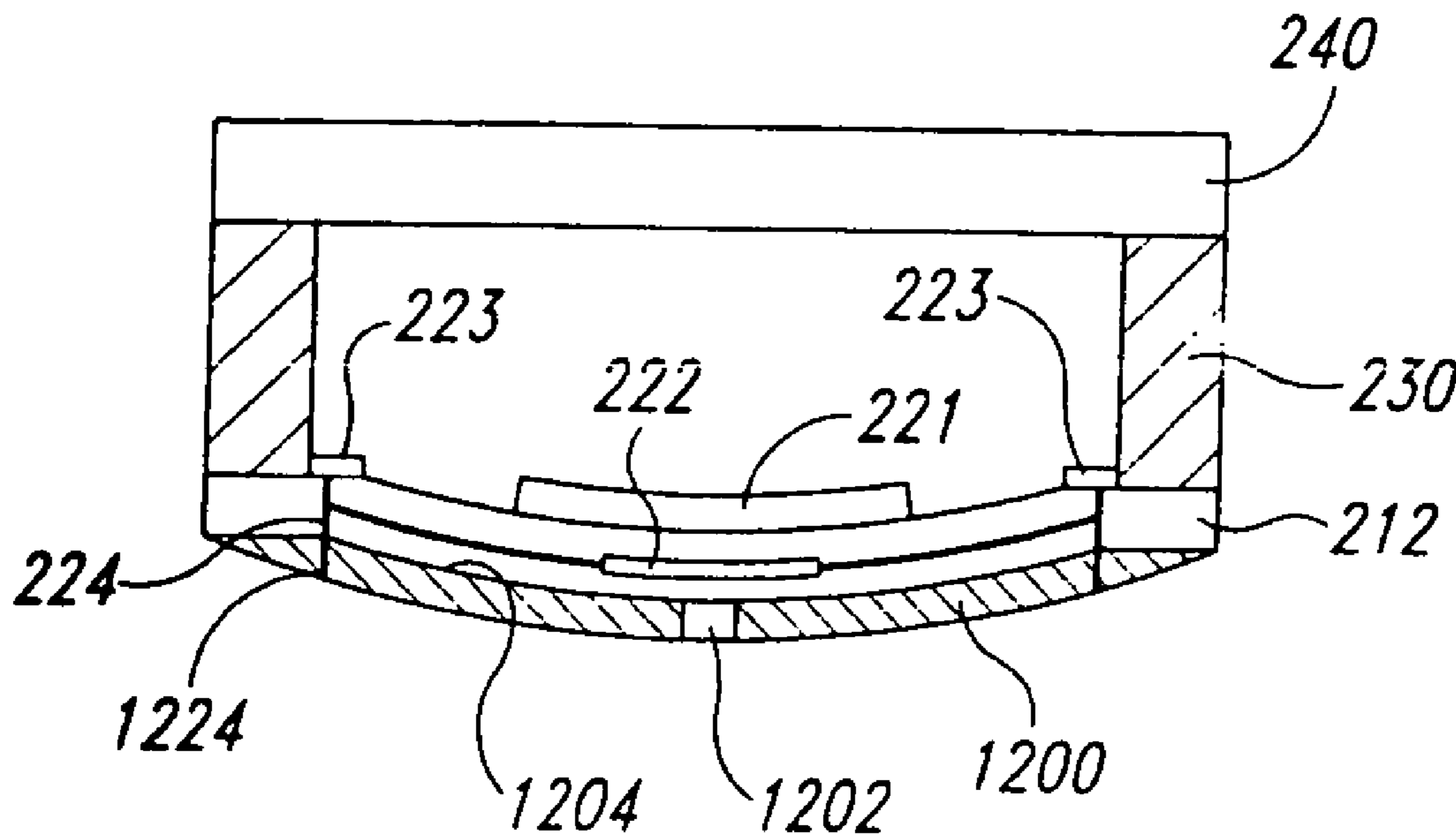

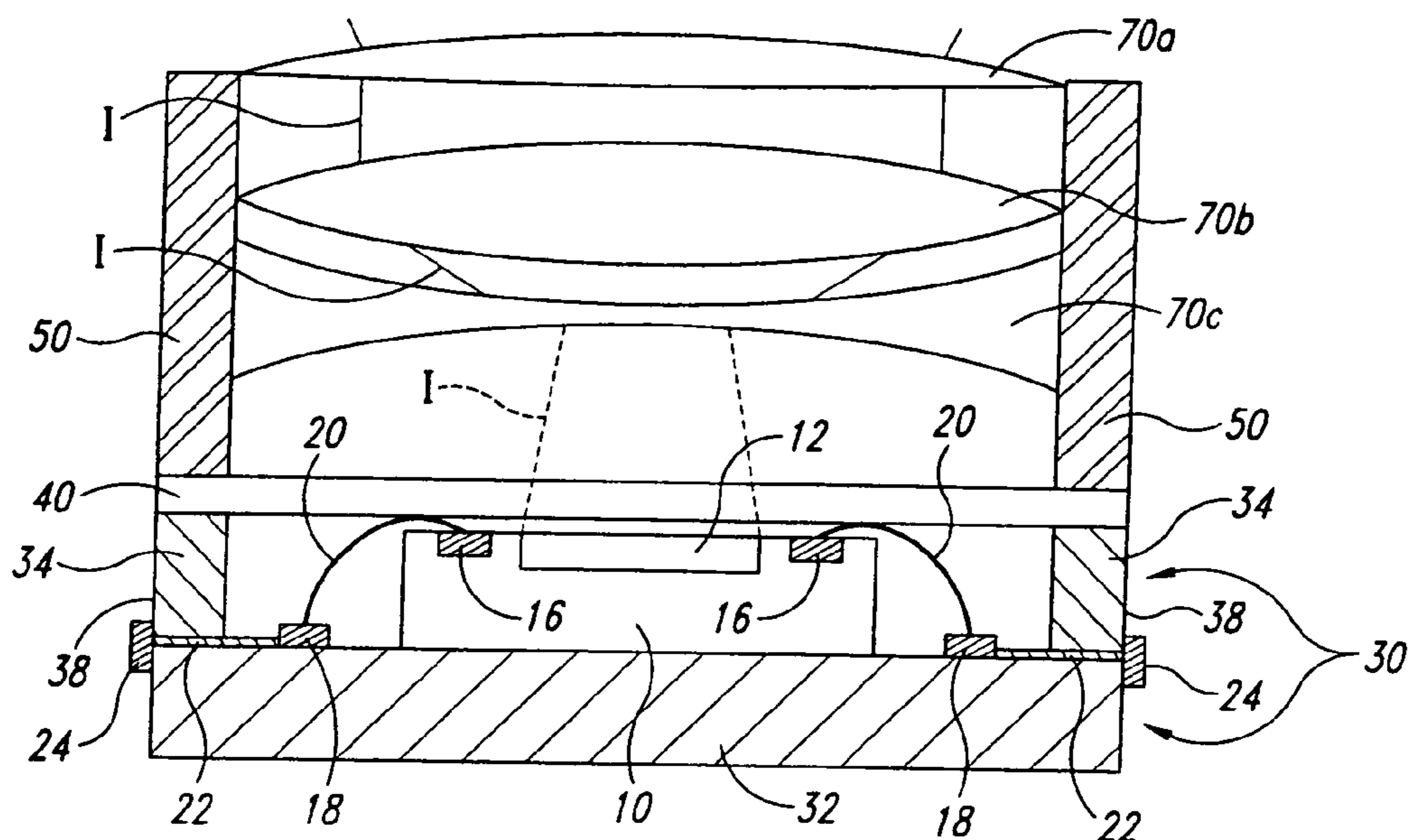

Fig. 1
(Prior Art)

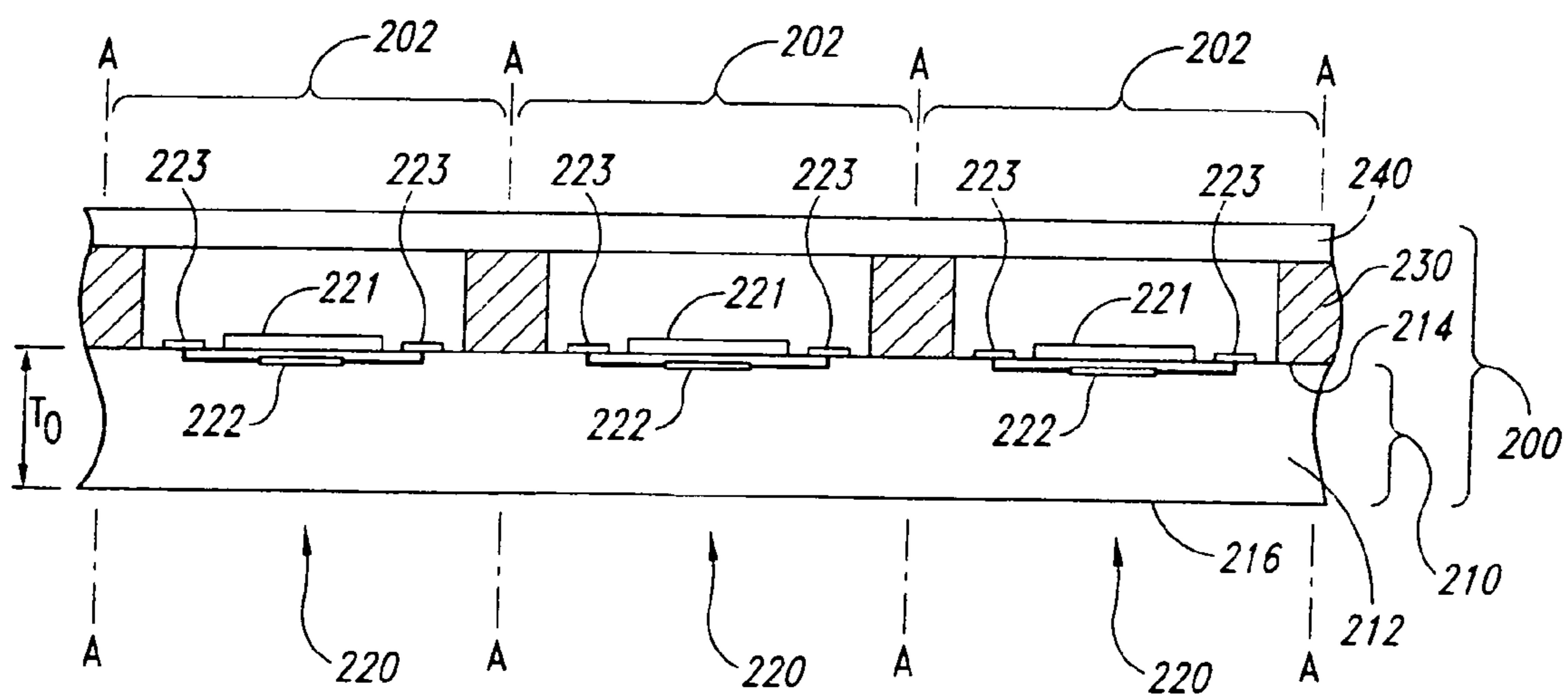

Fig. 2

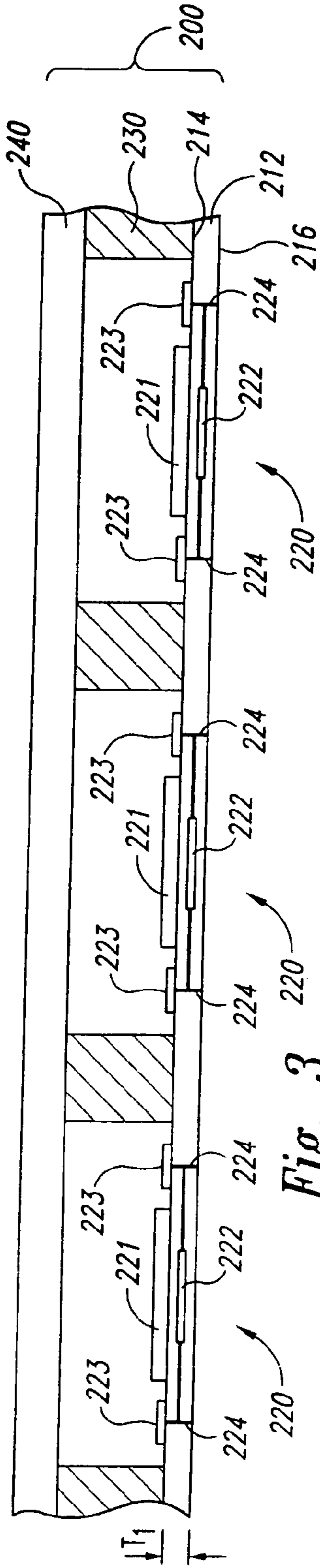

Fig. 3

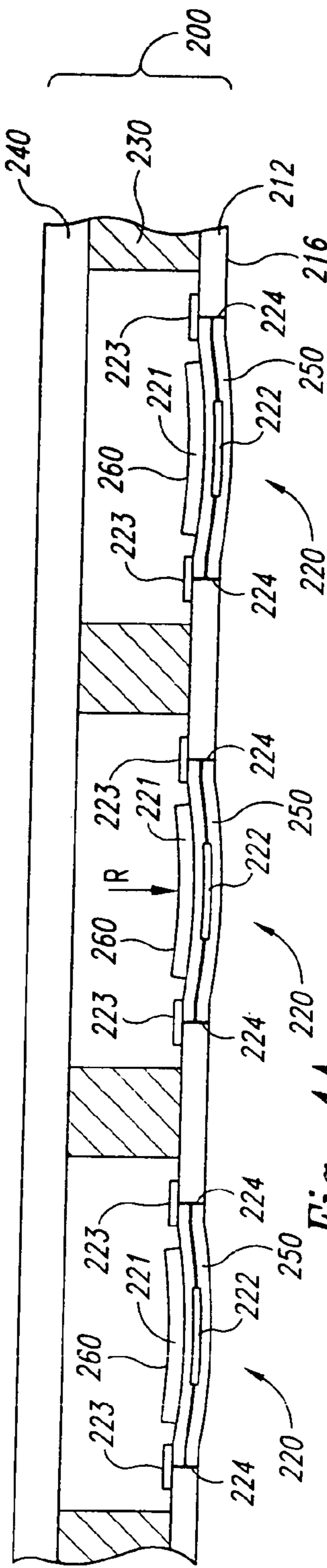

Fig. 4A

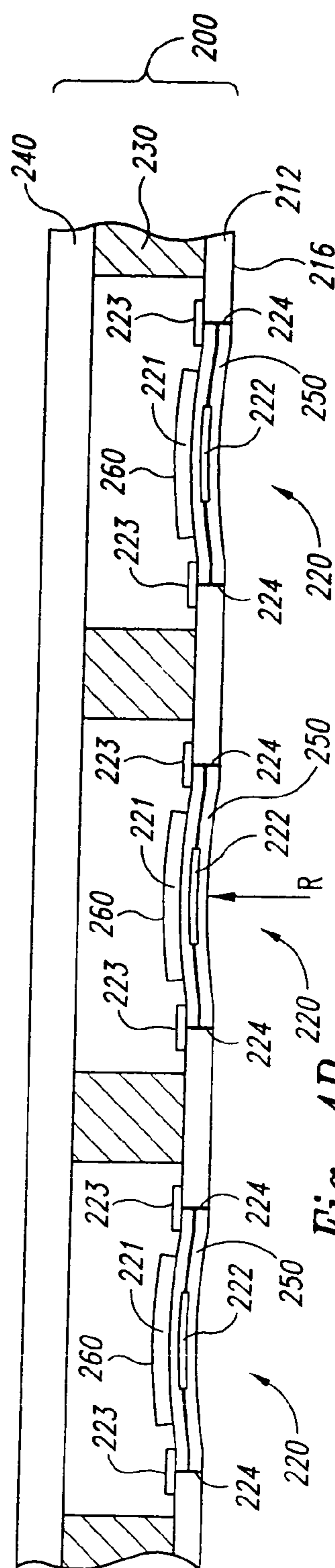

Fig. 4B

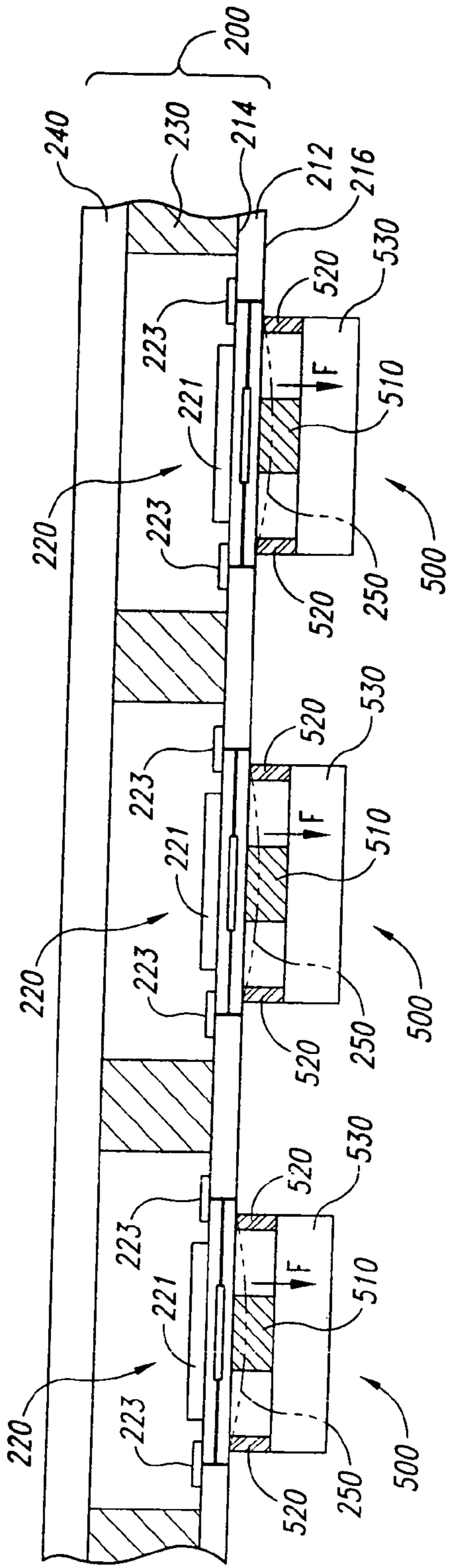

Fig. 5

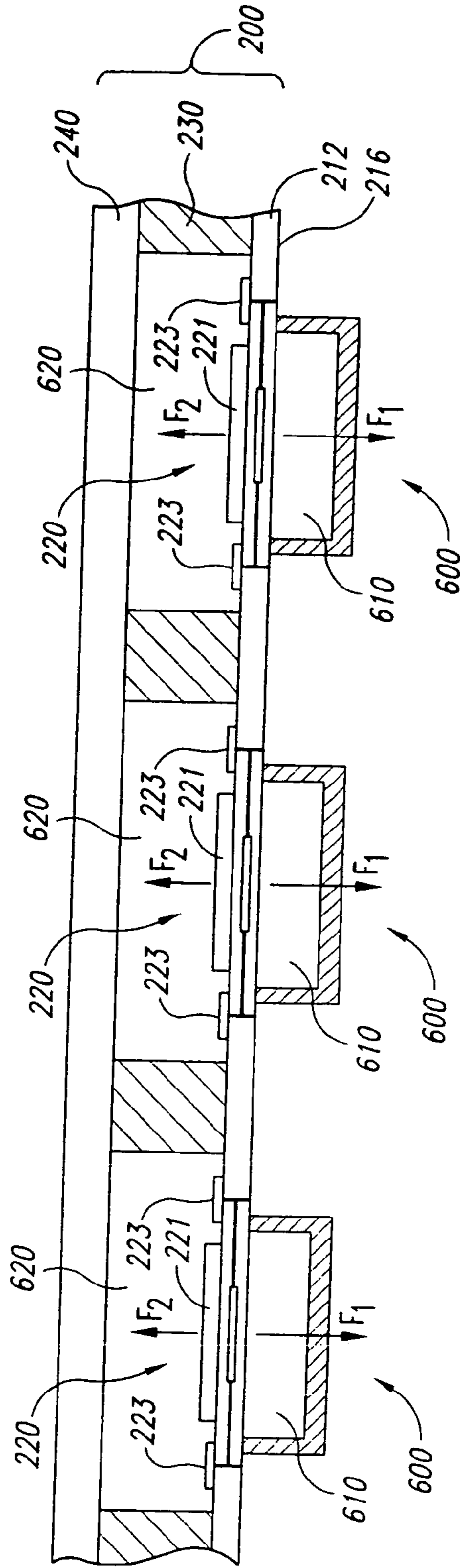

Fig. 6

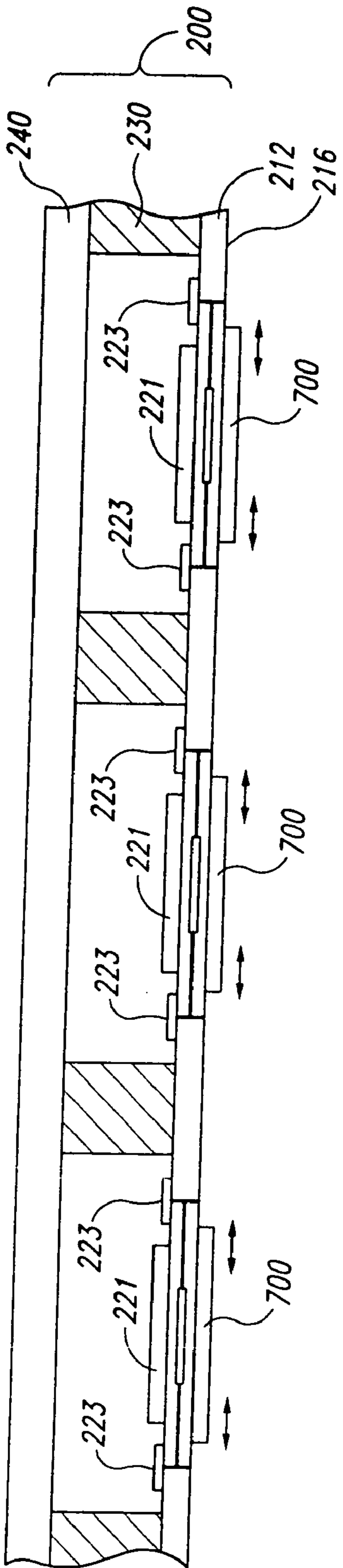

Fig. 7

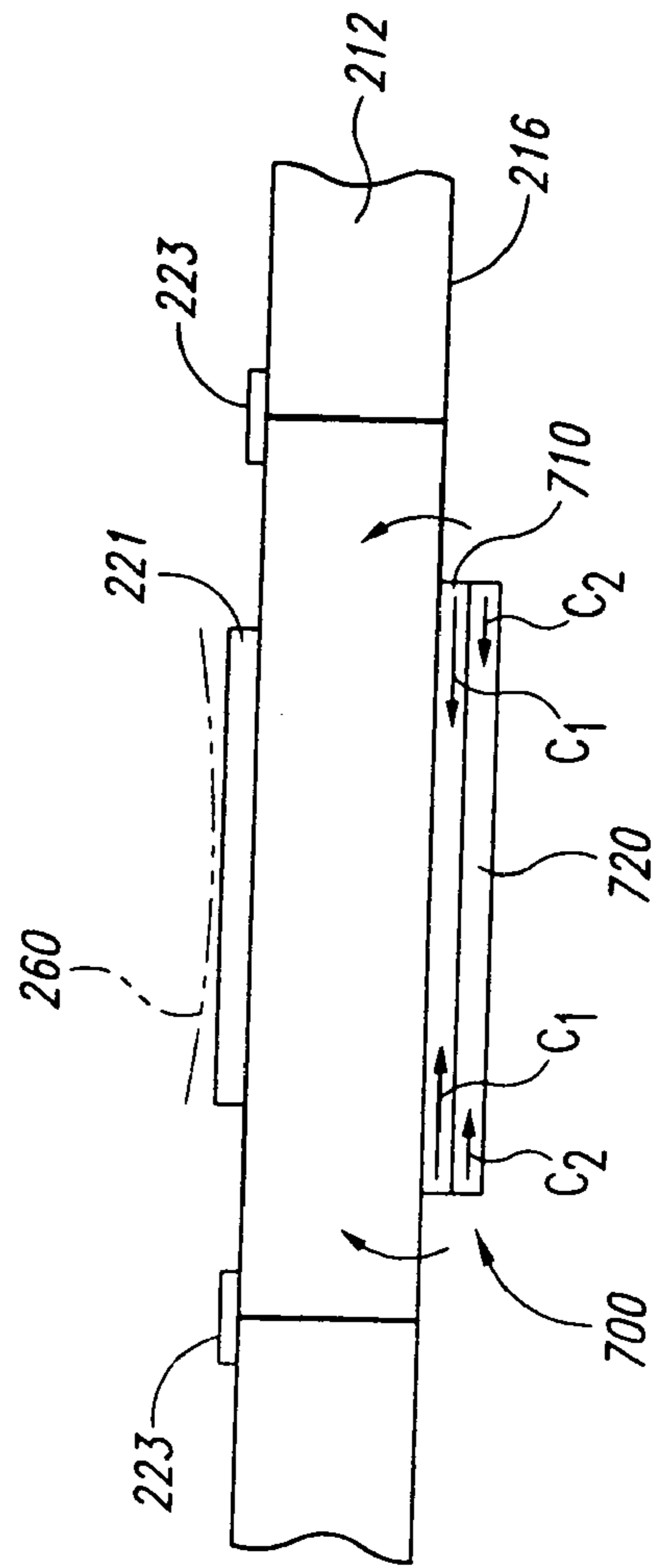

Fig. 8

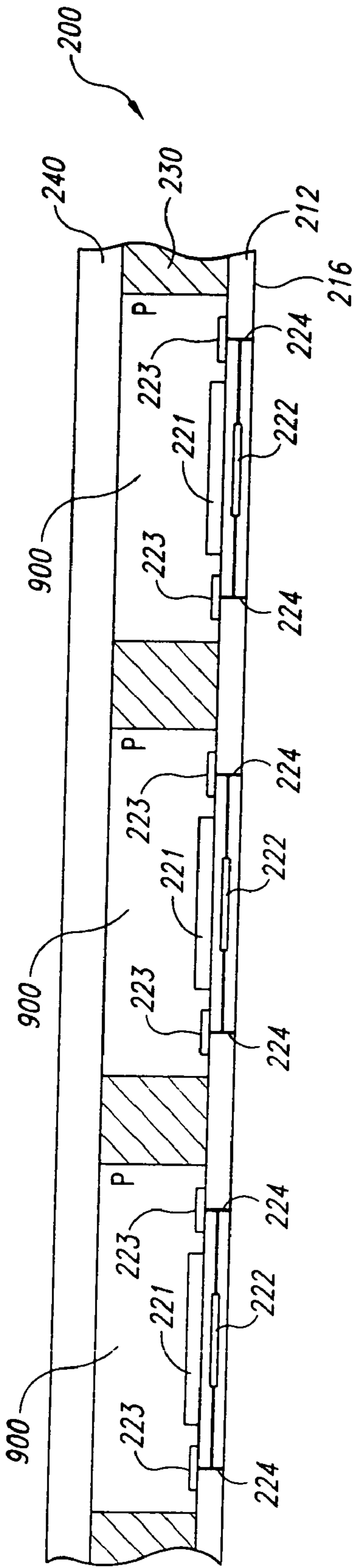

Fig. 9

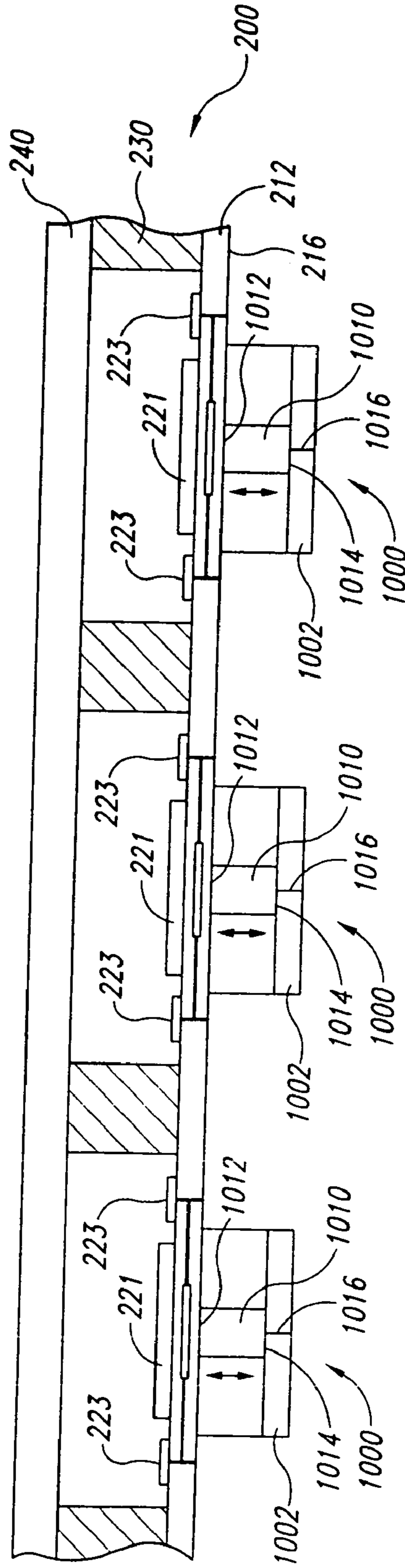

Fig. 10

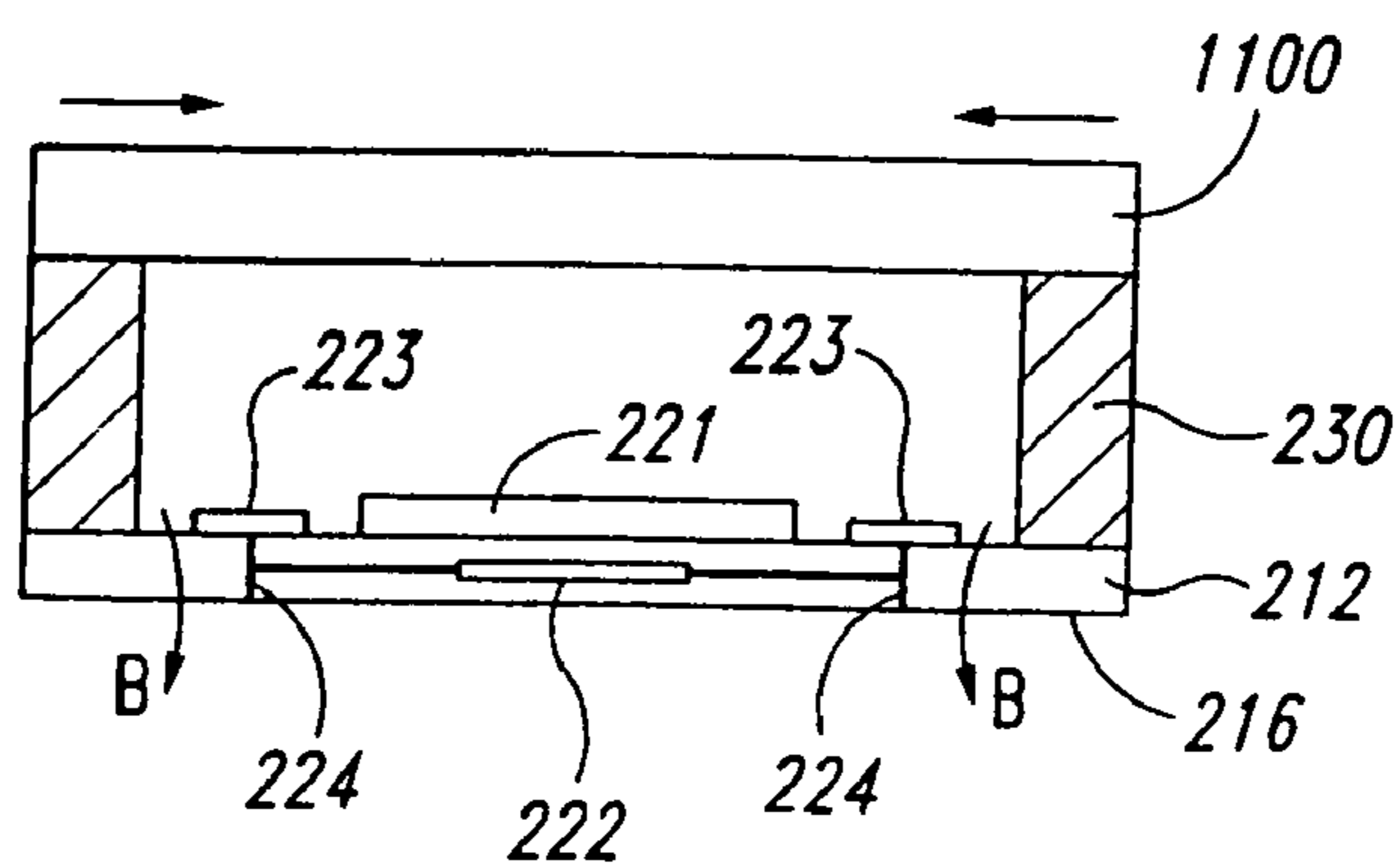

Fig. 11

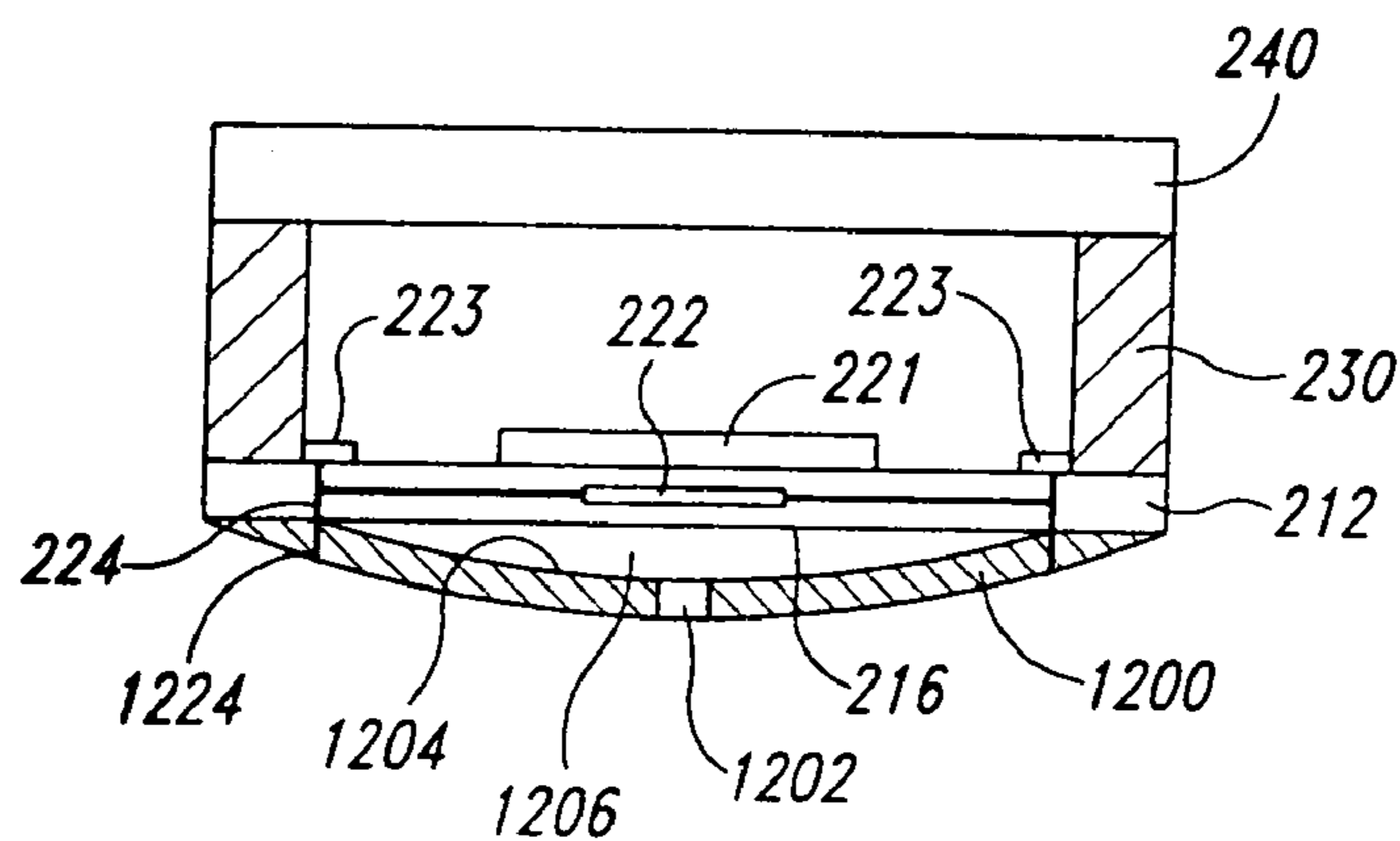

Fig. 12A

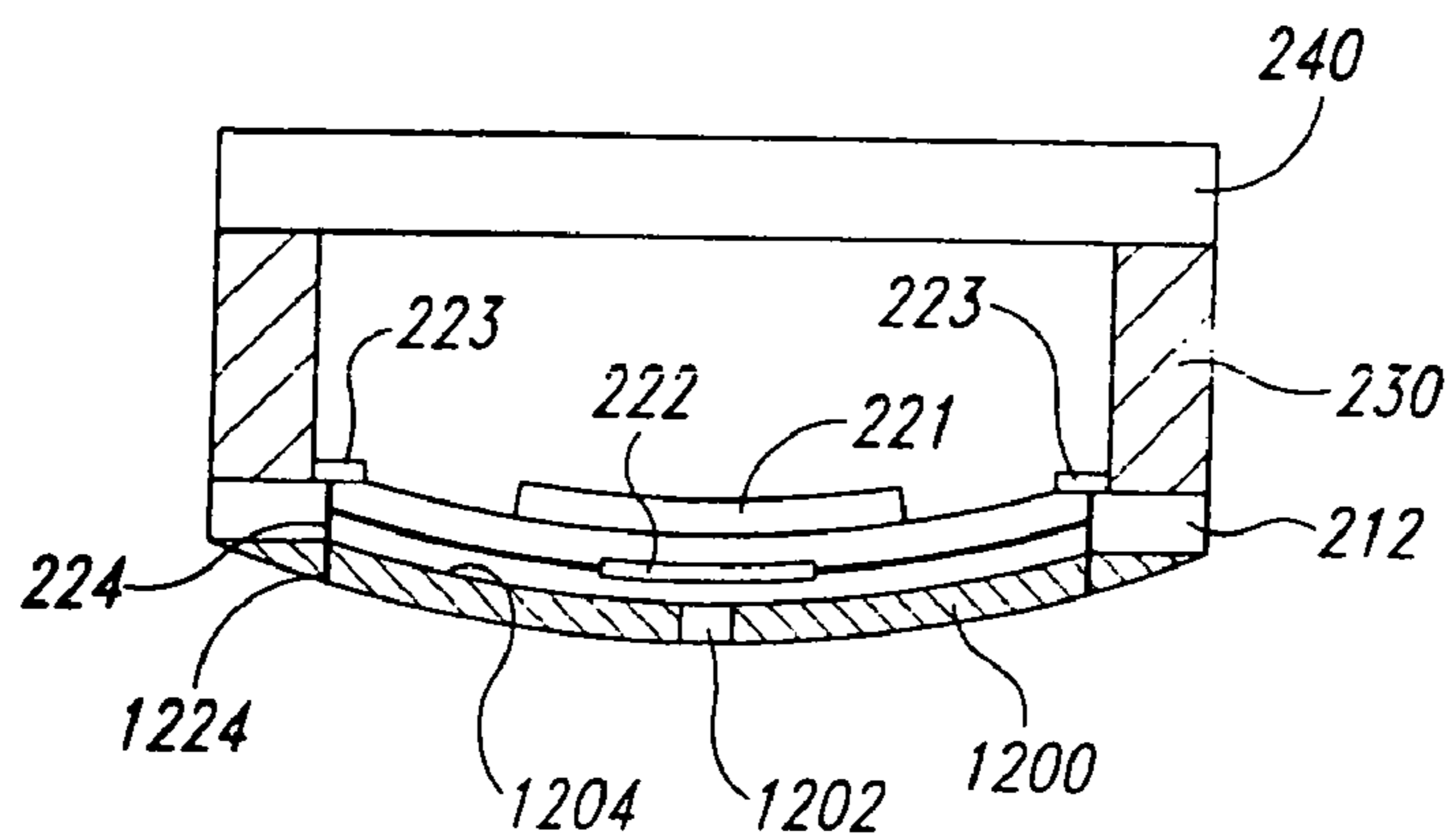

Fig. 12B

**MICROELECTRONIC IMAGERS WITH
CURVED IMAGE SENSORS AND METHODS
FOR MANUFACTURING
MICROELECTRONIC IMAGERS**

TECHNICAL FIELD

[0001] The present invention generally relates to microelectronic imagers with curved image sensors and methods for forming curved image sensors for use in such microelectronic imagers.

BACKGROUND

[0002] Microelectronic imagers are used in digital cameras, wireless devices with picture capabilities, and many other applications. Cell phones and Personal Digital Assistants (PDAs), for example, incorporate microelectronic imagers for capturing and sending pictures. The growth rate of microelectronic imagers has been steadily increasing as they become smaller and produce better images with more pixels.

[0003] Microelectronic imagers include image sensors that use Charged Coupled Device (CCD) systems, Complementary Metal-Oxide Semiconductor (CMOS) systems, or other solid-state systems. CCD image sensors have been widely used in digital cameras and other applications. CMOS image sensors are also quickly becoming very popular because they are expected to have low production costs, high yields, and small sizes. CMOS image sensors can provide these advantages because they are manufactured using technology and equipment developed for fabricating semiconductor devices. CMOS image sensors, as well as CCD image sensors, are accordingly "packaged" to protect delicate components and to provide external electrical contacts.

[0004] FIG. 1 is a schematic side cross-sectional view of a conventional microelectronic imaging unit 1 including an imaging die 10, a chip carrier 30 carrying the die 10, and a cover 40 attached to the chip carrier 30 and positioned over the die 10. The imaging die 10 includes an image sensor 12 and a plurality of bond-pads 16 operably coupled to the image sensor 12. The chip carrier 30 has a base 32, sidewalls 34 projecting from the base 32, and a recess defined by the base 32 and sidewalls 34. The die 10 is received within the recess and attached to the base 32. The chip carrier 30 further includes an array of terminals 18 on the base 32, an array of contacts 24 on an external surface 38, and a plurality of traces 22 electrically connecting the terminals 18 to corresponding external contacts 24. The terminals 18 are positioned between the die 10 and the sidewalls 34 so that wire-bonds 20 can electrically couple the terminals 18 to corresponding bond-pads 16 on the die 10.

[0005] One problem with the microelectronic imaging unit 1 illustrated in FIG. 1 is that the die 10 must fit within the recess of the chip carrier 30. Dies having different shapes and/or sizes accordingly require chip carriers configured to house those specific types of dies. As such, manufacturing imaging units with dies having different sizes requires fabricating various configurations of chip carriers and significantly retooling the manufacturing process.

[0006] Another problem with conventional microelectronic imaging units is that they have relatively large footprints. For example, the footprint of the imaging unit 1 in FIG. 1 is the surface area of the base 32 of the chip carrier 30, which is significantly larger than the surface area of the die 10. Accordingly, the footprint of conventional microelectronic

imaging units can be a limiting factor in the design and marketability of picture cell phones or PDAs because these devices are continually being made smaller in order to be more portable. Therefore, there is a need to provide microelectronic imaging units with smaller footprints.

[0007] The imager 1 shown in FIG. 1 also has an optics unit including a support 50 attached to the chip carrier 30 and a lens system with a plurality of lenses 70 (identified individually by reference numbers 70a-c). Traditional lens systems include a plurality of lenses for focusing the image at the image sensor 12. Traditional lens systems accordingly flatten the field of the image at the image sensor 12 so that the image is focused across the face of the image sensor 12. In the embodiment shown in FIG. 1, for example, the lens 70c may flatten the image "I" across the face of the image sensor 12. In other conventional systems, one or more of the lenses 70a-c can be combined into a single aspherical lens that can focus and flatten an image.

[0008] Another problem with conventional microelectronic imaging units that lens systems with multiple lenses or more complex aspherical lenses are relatively tall and complex. Conventional lens systems accordingly have high profiles, can be expensive to manufacture, and may be difficult to assemble. Therefore, it would be desirable to reduce the demands and complexity of lens systems in the manufacturing of microelectronic imagers.

BRIEF DESCRIPTION OF THE DRAWINGS

[0009] FIG. 1 is a schematic side cross-sectional view of a packaged microelectronic imager in accordance with the prior art.

[0010] FIG. 2 is a cross-sectional view illustrating one stage of fabricating a plurality of microelectronic imagers at the wafer level in accordance with an embodiment of the invention.

[0011] FIG. 3 is a cross-sectional view illustrating a subsequent stage of fabricating a plurality of microelectronic imagers at the wafer level in accordance with an embodiment of the invention.

[0012] FIGS. 4A and 4B are schematic side cross-sectional views illustrating alternative embodiments of microelectronic imagers fabricated in accordance with an embodiment of the invention.

[0013] FIG. 5 is a cross-sectional view illustrating an embodiment for forming curved image sensors in microelectronic imagers in accordance with an embodiment of the invention.

[0014] FIG. 6 is a cross-sectional view illustrating an embodiment for forming curved image sensors in microelectronic imagers in accordance with another embodiment of the invention.

[0015] FIG. 7 is a cross-sectional view illustrating an embodiment for forming curved image sensors in microelectronic imagers in accordance with another embodiment of the invention.

[0016] FIG. 8 is a cross-sectional view illustrating a process for bending a substrate to fabricate curved microelectronic imagers in accordance with a specific embodiment of the method shown in FIG. 7.

[0017] FIG. 9 is a cross-sectional view illustrating another embodiment for fabricating curved image sensors in accordance with the invention.

[0018] FIG. 10 is a cross-sectional view illustrating a device and method for fabricating curved image sensors in accordance with still another embodiment of the invention.

[0019] FIG. 11 is a cross-sectional view illustrating a device and method for fabricating curved image sensors in accordance with yet another embodiment of the invention.

[0020] FIGS. 12A and 12B are cross-sectional views illustrating a device and a process for fabricating curved image sensors in accordance with an embodiment of the invention.

DETAILED DESCRIPTION

A. Overview

[0021] The following disclosure describes several embodiments of microelectronic imagers having curved image sensors and methods for fabricating such microelectronic imagers at the wafer level and at the individual die level. In one embodiment, a microelectronic imager device comprises an imager die having a substrate, a curved microelectronic image sensor having a convex and/or concave face at one side of the substrate, and integrated circuitry in the substrate operatively coupled to the image sensor. The imager die can further include external contacts electrically coupled to the integrated circuitry and a cover over the curved image sensor.

[0022] The curved microelectronic image sensor can have a convex and/or concave face with a desired radius of curvature. For example, the curved image sensor can have a face with a single radius of curvature, a plurality of curves with different radii, and/or flat portions in combination with one or more curves. The curved face of the image sensor is expected to receive a generally spherical image field such that the lens assembly does not need to significantly flatten the field to compensate for a planar sensor array.

[0023] In an alternative embodiment, a microelectronic imager device includes an imager die having a substrate with a bowed portion, a microelectronic image sensor having a curved face at the bowed portion of the substrate, and integrated circuitry electrically coupled to the image sensor. The imager device can further include a flexor unit that exerts a force against the substrate to bend or otherwise flex the substrate to form the bowed portion under the image sensor. The flexor unit, for example, can include a first element attached to a first region of the substrate under an image sensor, a spacer attached to the substrate outwardly of the first element, and a plate attached to the first element and the spacer. The first element expands or contracts more or less than the spacer to flex the substrate. The flexor unit can alternatively comprise a compartment at the front side and/or the backside of the substrate and a fluid in the compartment at a pressure that causes the substrate to bow. Another embodiment of the flexor unit can comprise a material attached to the backside of the substrate that bends the substrate into a desired curvature. The flexor unit can alternatively comprise an actuator attached to the backside of the substrate to flex the substrate and bend the image sensor into a desired curvature.

[0024] Another aspect of the invention is a method for manufacturing microelectronic imager devices. In one embodiment, a such method includes constructing an imager die having a substrate, integrated circuitry in the substrate, and an image sensor having a curved face at one side of the substrate. This method can further include positioning a cover over the substrate and/or bending the substrate to flex the image sensor.

[0025] Several details of specific embodiments of the invention are described below with reference to CMOS imagers to provide a thorough understanding of these embodiments. CCD imagers or other types of sensors, however, can be used instead of CMOS imagers in other embodiments of the invention. Several details describing well known structures often associated with microelectronic devices may not be set forth in the following description for the purposes of brevity. Moreover, other embodiments of the invention can have different configurations or different components than those described and shown in this section. As such, other embodiments of the invention may have additional elements or may not include all the elements shown and described below with reference to FIGS. 2-12B.

B. Microelectronic Imagers with Curved Image Sensors

[0026] FIG. 2 is a side cross-sectional view illustrating an imager unit assembly 200 having a plurality of microelectronic imager units 202 at one stage of a method for packaging imagers in accordance with an embodiment of the invention. The assembly 200 illustrated in FIG. 2 includes an imager workpiece 210, standoffs 230 projecting from the imager workpiece 210, and a cover 240 attached to the standoffs 230. A plurality of optics units (not shown) are typically mounted to the cover 240 either before or after forming curved image sensors on the imager workpiece 210 to fabricate microelectronic imagers.

[0027] The imager workpiece 210 includes a substrate 212 having a front side 214, a backside 216, and an initial thickness T_0 between the front side 214 and backside 216. The imager workpiece 210 further includes a plurality of imaging dies 220 formed on and/or in the substrate 212. Individual imaging dies 220 can include an image sensor 221, integrated circuitry 222 operatively coupled to the image sensor 221, and terminals 223 (e.g., bond-pads) electrically coupled to the integrated circuitry 222. The image sensors 221 can be CMOS devices, CCD image sensors, or other solid state devices for capturing pictures in the visible spectrum or sensing radiation in other spectrums (e.g., IR or UV ranges). As explained in more detail below, the terminals 223 can be connected to through-wafer interconnects formed according to the processes disclosed in U.S. patent application Ser. No. 10/713,878 entitled "Microelectronic Devices, Methods for Forming Vias in Microelectronic Devices, and Methods for Packaging Microelectronic Devices," filed on Nov. 13, 2003, which is incorporated by reference herein in its entirety. Other embodiments of external contacts can include terminals that are at an intermediate depth within the first substrate 212 instead of being at the front side 214.

[0028] The embodiment of the imager unit assembly 200 illustrated in FIG. 2 is fabricated at the wafer level such that several imaging units 202 are packaged before singulating (e.g., cutting) the first substrate 212, the spacers 230 and the cover 240 along lines A-A. One aspect of wafer-level packaging is using automated equipment to further process the assembly 200 to form curved image sensors and to install optics units (not shown) onto the cover 240. FIGS. 3-4B illustrate several aspects of forming curved image sensors and embodiments of assemblies having curved image sensors.

[0029] FIG. 3 illustrates the imager unit assembly 200 at a subsequent stage of a process for forming curved image sensors on the imaging dies 220. At this stage of the process, the substrate 212 has been thinned from the initial thickness T_0 to a thickness T_1 so that the portions of the substrate 212 between the standoffs 230 are at least relatively flexible. In

several embodiments, the substrate **212** can be thinned using a back grinding process, a chemical-mechanical planarization process, and/or an etching procedure known in the art to form a new backside **216**. The final thickness T_1 between the front side **214** and the backside **216** can be in the range of approximately 20-200 μm depending upon the type of material. When the substrate **212** is composed of silicon, the thickness T_1 is generally less than approximately 150 μm and can be in the range of approximately 20-80 μm . The very thin portions of the substrate **212** between the standoffs **230** acts much like a flexible membrane, and as such the portions of the substrate **212** under the image sensors **221** can be flexed to bend the image sensors **221**. After thinning the substrate, the assembly **200** illustrated in FIG. 3 can be further processed to construct the through-wafer interconnects **224** through the substrate **212** to provide electrical contacts on the backside **216** of the substrate **212**. Additional suitable processes for forming such interconnects are disclosed in U.S. application Ser. No. 10/879,838, which is herein incorporated by reference.

[0030] FIG. 4A is a cross-sectional view illustrating one embodiment of the imager unit assembly **200** after bending the substrate **212** to form curved image sensors **221**. In this embodiment, the substrate **212** has curved portions **250** in the areas aligned with the image sensors **221**. The curved portions **250** are generally discrete bowed regions of the substrate **212** that form projecting bumps on the backside **216**. In one embodiment, the curved portions **250** have a shape of a portion of a sphere with a radius of curvature R . The curved portions **250** are not limited to a spherical configuration and can have other configurations with one or more curves and/or flat portions depending upon the particular application.

[0031] The image sensors **221** flex as the curved portions **250** of the substrate **212** are formed such that the image sensors **221** have curved faces **260**. The curvature of each curved face **260** is configured so that the array on the curved face **260** is at a desired focal distance for the image. In the embodiment illustrated in FIG. 4A, the curved image sensors **221** have concave curved faces **260** relative to the direction of the radiation to accommodate non-planar image fields.

[0032] The curved image sensors **221** with the curved faces **260** are expected to (a) reduce the complexity of fabricating lens systems and (b) increase the options of lens systems that can be used with the imagers. For example, because the image sensors **221** have curved faces **260**, the image field does not need to be flattened using optics to the same extent as image fields need to be flattened for planar image sensors. This is expected to eliminate the need for field flattening lenses in the optics units that are attached to the cover **240**, or at least reduce the complexity of field flattening lenses. Therefore, the imaging dies **220** illustrated in FIG. 4A reduce the constraints on lens designs such that fewer lenses or less complex lenses can be used to reduce the cost of fabricating micro-electronic imagers.

[0033] The curved image sensors **221** illustrated in FIG. 4A are also advantageous because they are particularly well-suited for miniature camera applications that require a wide-angle field of view and/or have a short focal distance. One problem with miniature cameras is that it is difficult to adequately flatten the image field because the focal distance between the lenses and the image sensors **221** is extremely short. As a result, images from conventional miniature cameras are typically focused at the center but out of focus at the periphery. The curved image sensors **221** mitigate this prob-

lem because the periphery of the image sensors **221** is at, or at least closer to, the desired focal distance of the image field. The curved image sensors **221** are also expected to be very useful for megapixel wide-angle applications that have longer focal distances for the same reason. Therefore, the curved image sensors **221** are further expected to provide better quality images for miniature cameras or other applications that have a wide-angle field of view.

[0034] FIG. 4B is a cross-sectional view illustrating another embodiment of the imager unit assembly **200** having a plurality of imaging dies **220** with curved image sensors **221**. In this embodiment, the curved portions **250** of the substrate **212** project into the cavity between the cover **240** and the substrate **212**. The curved portions **250** accordingly form small discrete dimples on the backside **216** of the substrate **212** such that the image sensors **221** have convex curved faces **260** relative to the direction of the radiation. As described above, the curved portions **250** can have the shape of a portion of a sphere having a radius of curvature R , but other configurations may also be suitable.

C. Methods and Devices for Forming Curved Image Sensors

[0035] FIG. 5 is a cross-sectional view of an embodiment of fabricating curved image sensors using a plurality of flexor units **500** attached to the backside **216** of the substrate **212**. The flexor units **500** can be positioned at each imaging die **220** or only at known-good imaging dies **220** depending upon the particular application. The individual flexor units **500** include a first element **510** attached to the backside **216** of the substrate **212** under a corresponding image sensor **221**. The first elements **510**, for example, can be expansion/contraction members attached to the substrate **212** at areas aligned with the central regions of the corresponding image sensors **221**. The individual flexor units **500** can further include a spacer **520** arranged outwardly from the first element **510** and a plate **530** attached to the first element **510** and the spacer **520**. In one embodiment, the first elements **510** are made from a material having a first coefficient of thermal expansion, and the spacers **520** are made from a material having a second coefficient of thermal expansion less than that of the first elements **510**. In other embodiments, the first elements **510** can be a shape memory metal, such as Nitinol, and the spacers **520** can be a substantially incompressible material.

[0036] The flexor units **500** operate by expanding/contracting the first elements **510** either more or less than the spacers **520** to bend the substrate **212** in the local regions under corresponding image sensors **221**. For example, the flexor units **500** can be attached to the substrate **212** at an elevated temperature, and then the assembly can be cooled such that the first elements **510** exert local forces (arrows F) that bend the substrate **212** into the concave curved portions **250** (shown in dashed lines) similar to those shown in FIG. 4A. The spacers **520** in this example contract less than the first elements **510** as they cool. Alternatively, the first elements **510** can have a lower coefficient of thermal expansion than the spacers **520** such that the first element **510** exerts a force in the opposite direction to form convex curved portions similar to those illustrated in FIG. 4B.

[0037] FIG. 6 is a cross-sectional view illustrating another embodiment for fabricating curved image sensors in micro-electronic imagers using a plurality of flexor units **600** attached to the backside **216** of the substrate **212** under corresponding imaging dies **220**. In this embodiment, individual flexor units **600** include a compartment **610** and a fluid in the

compartment 610 at a pressure that causes the substrate 212 to bow (not shown in FIG. 6) in a manner that flexes a corresponding image sensor 221. In one embodiment, the compartments 610 can be attached to the substrate 212 in a low pressure environment such that the pressure inside the compartments 610 is less than the pressure in chambers 620 over the corresponding image sensors 221. The pressure differential between the compartments 610 and the chambers 620 exerts a force F_1 that draws the portions of the substrate 212 under the image sensors 221 into the compartments 610 to form curved portions (not shown) similar to the concave curved portions 250 illustrated above with respect to FIG. 4A. Alternatively, the compartments 610 can be attached to the substrate 212 in a high pressure environment such that the pressure in the compartments 610 is greater than the pressure in the chambers 620. This second embodiment exerts a force F_2 against the substrate 212 to drive the portions of the substrate 212 under the image sensors 221 into the chambers 620 to form a convex curvature on the image sensors 221 as illustrated above with respect to FIG. 4B. The pressure in the compartments 610 can also be set by vacuuming or pressurizing the compartments 610 using gas or fluid lines connected to the compartments 610.

[0038] FIG. 7 is a cross-sectional view illustrating yet another embodiment for forming curved image sensors on the assembly 200 using flexor units 700 attached to the backside 216 of the substrate 212 underneath corresponding image sensors 221. In this embodiment, the flexor units 700 can be a material that expands or contracts in a manner that bends the portions of the substrate 212 under the image sensors 221 into a concave and/or convex curvature. The flexor units 700, for example, can be an epoxy deposited onto the backside 216 of the substrate 212 and then cured in a manner that causes the epoxy to contract. As the epoxy contracts, it is expected to bend the substrate 212 to form convex curved portions similar to those illustrated above with respect to FIG. 4B. The epoxy can be deposited in many configurations, including a circle, radial starburst pattern, or other suitable pattern. The flexor units 700 can alternatively be small members of a shape memory alloy that assumes a desired configuration when it is in an operating temperature range. For example, the shape memory alloy may be attached to the substrate 212 at a first temperature and then expand, contract or otherwise flex as it reaches an operating temperature range to bend the local regions of the substrate 212 under the image sensors 221 in a manner that forms concave and/or convex portions similar to those illustrated above with respect to FIG. 4A or 4B.

[0039] FIG. 8 is a cross-sectional view illustrating yet another embodiment of a flexor unit 700 having a first material 710 and a second material 720. The first material 710 typically has a higher coefficient of thermal expansion than the second material 720. As such, when the flexor 700 cools to an operating temperature range, the first material 710 contracts by a greater extent (arrows C_1) than the second material 720 (arrows C_2). The difference in contraction is expected to cause the flexor unit 700 to exert a downward force against the substrate 212 to form a concave curved face 260 (illustrated in dashed lines). In one embodiment, the first layer 710 can be composed of aluminum and the second layer 720 can be composed of Kovar to form a bimetallic plate.

[0040] FIG. 9 illustrates another embodiment for bending the image sensors 221 to have curved faces with a desired curvature. In this embodiment, flexor units 900 are defined by sealed chambers over the image sensors 221 and a fluid in the

sealed chambers at a pressure P. The pressure of the fluid causes the substrate 212 to flex in the regions under the image sensors 221 as shown in FIGS. 4A and 4B. In one embodiment, the cover 240 is assembled to the standoffs 230 in an environment at a pressure higher than ambient pressure such that the pressure in the sealed chambers drives the portions of the substrate 212 under the image sensors 221 outwardly to form the concave faces on the image sensors as illustrated in FIG. 4A. In an alternative embodiment, the cover 240 is assembled to the spacers 230 in an environment at a pressure lower than the ambient temperature such that the substrate 212 is drawn into the compartments to form convex curved faces on the image sensors as illustrated in FIG. 4B.

[0041] FIG. 10 illustrates another embodiment for bending the image sensors into a desired curvature in accordance with the invention using a plurality of flexor units 1000 attached to the backside of the substrate 212 under corresponding image sensors 221. In this embodiment, the individual flexor units 1000 include a bracket 1002 attached to the backside 216 of the substrate 212 and an actuator 1010 attached to the bracket 1002. The actuator 1010 can have a first end 1012 in contact with the backside 216 of the substrate 212 underneath a central portion of a corresponding image sensor 221. The actuator 1010 can further include a second end 1014 attached to the bracket 1002 and a line 1016 for transmitting electrical signals or carrying fluids to control the actuator 1010. In one embodiment, the actuator 1010 is a piezoelectric element and the line 1016 is an electrically conductive wire that can be coupled to a control unit. In a different embodiment, the actuator can be a bladder or other type of structure that can be expanded/contracted by adjusting a fluid pressure. In still another embodiment, the actuator 1010 can be a pneumatic or hydraulic cylinder. In operation, the actuator 1010 moves upwardly to form a convex curved face on the image sensor 221 (see FIG. 4B) or downwardly to form a concave curved face on the image sensor 221 (see FIG. 4A). The actuators 1010 can also be operated in real time while using an imaging unit to provide fine adjustment of the focus for wide-angle applications and other applications.

[0042] FIG. 11 illustrates still another embodiment for bending the image sensors into a desired curvature. In this embodiment, a flexor unit 1100 is defined by a transparent cover attached to the standoff 230 at an elevated temperature. The transparent flexor unit 1100 has a coefficient of thermal expansion greater than that of the substrate 212 such that the flexor unit 1100 contracts more than the substrate 212 as the assembly is cooled. The corresponding contraction of the flexor unit 1100 causes the substrate 212 to bend as shown by arrows B to form a concave curved face on the image sensor 221 as shown above with respect to FIG. 4A.

[0043] FIGS. 12A and 12B are cross-sectional views that illustrate still another embodiment for bending the image sensors into a desired curvature in accordance with the invention using curved flexor units 1200 attached to the backside of the substrate 212. The flexor units 1200 are vacuum cups having an opening 1202 and an interior surface 1204 with a curvature corresponding to the desired curvature for the image sensors 221. FIG. 12A illustrates the process before the substrate 212 is bent to form the curved face on the image sensor 221. At this stage, there is a gap 1206 between the backside 216 of the substrate 212 and the interior surface 1204 of the flexor unit 1200. To bend the substrate 212, a vacuum is drawn through the opening 1202. Referring to FIG. 12B, the vacuum drawn through the opening 1202 draws the

backside **216** of the substrate **212** against the interior surface **1204** of the flexor unit **1200**. The backside **216** of the substrate **212** and/or the interior surface **1204** of the flexor unit **1200** can be covered with an adhesive that adheres the backside **216** of the substrate **212** to the interior surface **1204** of the flexor unit **1200**. The flexor unit **1200** can further include interconnects **1224** that contact the interconnects **224** to carry the backside electrical contacts from the substrate **212** to the exterior surface of the flexor unit **1200**.

[0044] From the foregoing, it will be appreciated that specific embodiments of the invention have been described herein for purposes of illustration, but that various modifications may be made without deviating from the spirit and scope of the invention. For example, the substrate **212** can have patterns of trenches or other voids etched on the front side **214** and/or the backside **216** to preferentially direct the flexure of the substrate **212** using any of the embodiments described above with respect to FIGS. **5-12B**. Similarly, ridges or other protrusions can be formed on the substrate **212** in lieu of or in addition to voids to preferentially direct the flexure of the substrate. Accordingly, the invention is not limited except as by the appended claims.

1-32. (canceled)

33. A microelectronic imager die comprising:

a substrate;

a microelectronic image sensor at one side of the substrate, the microelectronic image sensor having a face for receiving radiation;

integrated circuitry electronically coupled to the image sensor; and

a flexor unit that bends a portion of the substrate and the image sensor.

34. The imager die of claim **33** wherein the flexor unit further comprises:

a first element attached to a backside of the substrate under a central portion of the image sensor; and

a spacer attached to the backside of the substrate outward of the first element.

35. The imager die of claim **34** -wherein the first element has a first coefficient of thermal expansion and the spacer has a different second coefficient of thermal expansion.

36. The imager die of claim **34** wherein the first element is a first compliant material and the spacer is a second compliant material.

37. The imager die of claim **33** wherein the flexor unit comprises a compartment attached to the backside of the substrate and a fluid in the compartment at a pressure that causes the substrate to bow.

38. The imager die of claim **33** wherein the flexor unit comprises a sealed compartment over the image sensor and fluid in the compartment at a pressure that causes the substrate to bow.

39. The imager die of claim **33** wherein the flexor unit comprises a material attached to the backside of the substrate that induces a force that bends the substrate.

40. The image die of claim **39** wherein the material comprises a bimetallic plate, a shape memory metal, and/or an epoxy.

41. The imager of claim **33** wherein the flexor unit comprises an actuator attached to the backside of the substrate, and wherein the actuator moves to flex the substrate and bend the image sensor.

42. A microelectronic workpiece, comprising:

a substrate having a plurality of imager dies, wherein individual imager dies include an image sensor having a curved face and integrated circuitry operatively coupled to the image sensor; and

a cover over the substrate.

43. The microelectronic workpiece of claim **42**, further comprising a plurality of backside flexor units attached to a backside of the substrate under the image sensors, and wherein individual flexor units comprise:

a first element, a spacer, and a plate, wherein at least the first element changes to bend the substrate under a corresponding image sensor.

44. The microelectronic workpiece of claim **43** wherein the first elements have a first coefficient of thermal expansion and the spacers have a different second coefficient of thermal expansion.

45. The microelectronic workpiece of claim **43** wherein the first elements are composed of a first compliant material and the spacers are composed of a second compliant material.

46. The microelectronic workpiece of claim **42**, further comprising a plurality of compartments attached to the backside of the substrate at corresponding imager dies, and wherein the compartments contain a fluid at a pressure that causes the substrate to flex under the image sensors.

47. The microelectronic workpiece of claim **46** wherein the fluid in the compartments is at a lower pressure than an ambient pressure.

48. The microelectronic workpiece of claim **46** wherein the fluid in the compartments is at a higher pressure than an ambient pressure.

49. The microelectronic workpiece of claim **42**, further comprising a material attached to the backside of the substrate under corresponding image sensors that bends the substrate locally under the image sensors.

50. The microelectronic workpiece of claim **49** wherein the material comprises an epoxy.

51. The microelectronic workpiece of claim **49** wherein the material comprises bimetallic plates and/or members made from a shape memory alloy.

52. The microelectronic workpiece of claim **42**, further comprising a standoffs between the cover and the substrate, sealed compartments over the image sensors, and a fluid in the compartments at a pressure that causes the substrate to bow locally at the image sensors.

53. The microelectronic workpiece of claim **51** wherein the fluid in the compartments is at a lower pressure than an ambient pressure.

54. The microelectronic workpiece of claim **51** wherein the fluid in the compartments is at a higher pressure than an ambient pressure.

55. The microelectronic workpiece of claim **42**, wherein the cover has a higher coefficient of thermal expansion from the substrate.

56. The microelectronic workpiece of claim **42**, further comprising a plurality of actuators attached to the backside of the substrate at the imager dies, wherein the actuators move local regions of the substrate to bow the substrate locally and flex the image sensors.

57. The microelectronic workpiece of claim **42**, further comprising a plurality of vacuum cups attached to the backside of the substrate, the individual vacuum cups having a curved interior surface adhered to the backside under a corresponding image sensor.

58-76. (canceled)

77. A microelectronic imager die comprising:

a substrate having a front side and a back side;

a microelectronic image sensor having a face for receiving radiation at the front side of the substrate;

integrated circuitry in the substrate electrically connected to the image sensor; and

a curved flexor unit having a curved surface, wherein the backside of the substrate in the region of the image sensor is attached to the curved surface of the flexor unit such that the substrate in the region of the image sensor at least generally conforms to the curved surface.

78. The die of claim **77**, wherein the curved flexor unit comprises a vacuum cup having an opening through which a vacuum can be drawn.

79. The die of claim **77**, wherein the curved flexor unit comprises a vacuum cup having an opening through which a vacuum can be drawn, and wherein the backside of the substrate is adhered to the curved surface of the vacuum cup.

80. The die of claim **77**, wherein the curved flexor unit comprises a vacuum cup having the curved surface and interconnects, and wherein the substrate further comprises backside interconnects electrically coupled to interconnects of the curved flexor unit and the integrated circuitry.

* * * * *