



(19) **United States**

(12) **Patent Application Publication**
Clayton et al.

(10) **Pub. No.: US 2008/0183307 A1**

(43) **Pub. Date: Jul. 31, 2008**

(54) **UPGRADEABLE AUTOMATION DEVICES, SYSTEMS, ARCHITECTURES, AND METHODS**

Publication Classification

(51) **Int. Cl.**
G05B 11/01 (2006.01)

(52) **U.S. Cl.** **700/8**

(75) **Inventors:** **Randy Clayton**, Frederick, MD (US); **Michael Antone**, Ellicott City, MD (US); **Daniel Rahme**, Ellicott City, MD (US)

(57) **ABSTRACT**

A multi-level automation control architecture, methods, and systems are disclosed, which provide enhanced scalability, functionality, and cost effectiveness for energy, access, and control. The systems include various combinations of automation controllers, remote controllers and peripheral devices that are used to provide monitoring and control functionality over the various systems in a structure, such as HVAC, water, lighting, etc. In various embodiments, the automation controller and various peripheral devices are implemented to provide an integrated energy management system for the structure. The system allows the user to manage energy based on the day, time, the presence of people, and the availability of natural lighting and heating, as well as prioritize and participate in demand-response program. The system can be implemented using a remote controller and expanded through the addition of automation controllers, remote controllers, and peripheral devices to enable the system to be tailored to specific user requirements.

Correspondence Address:
MICHAEL ANTONE
7160 RIVERWOOD DRIVE, SUITE 150
COLUMBIA, MD 21046

(73) **Assignee:** **Autani Corporation**, Columbia, MD (US)

(21) **Appl. No.:** **11/971,464**

(22) **Filed:** **Jan. 9, 2008**

Related U.S. Application Data

(60) Provisional application No. 60/886,918, filed on Jan. 26, 2007.

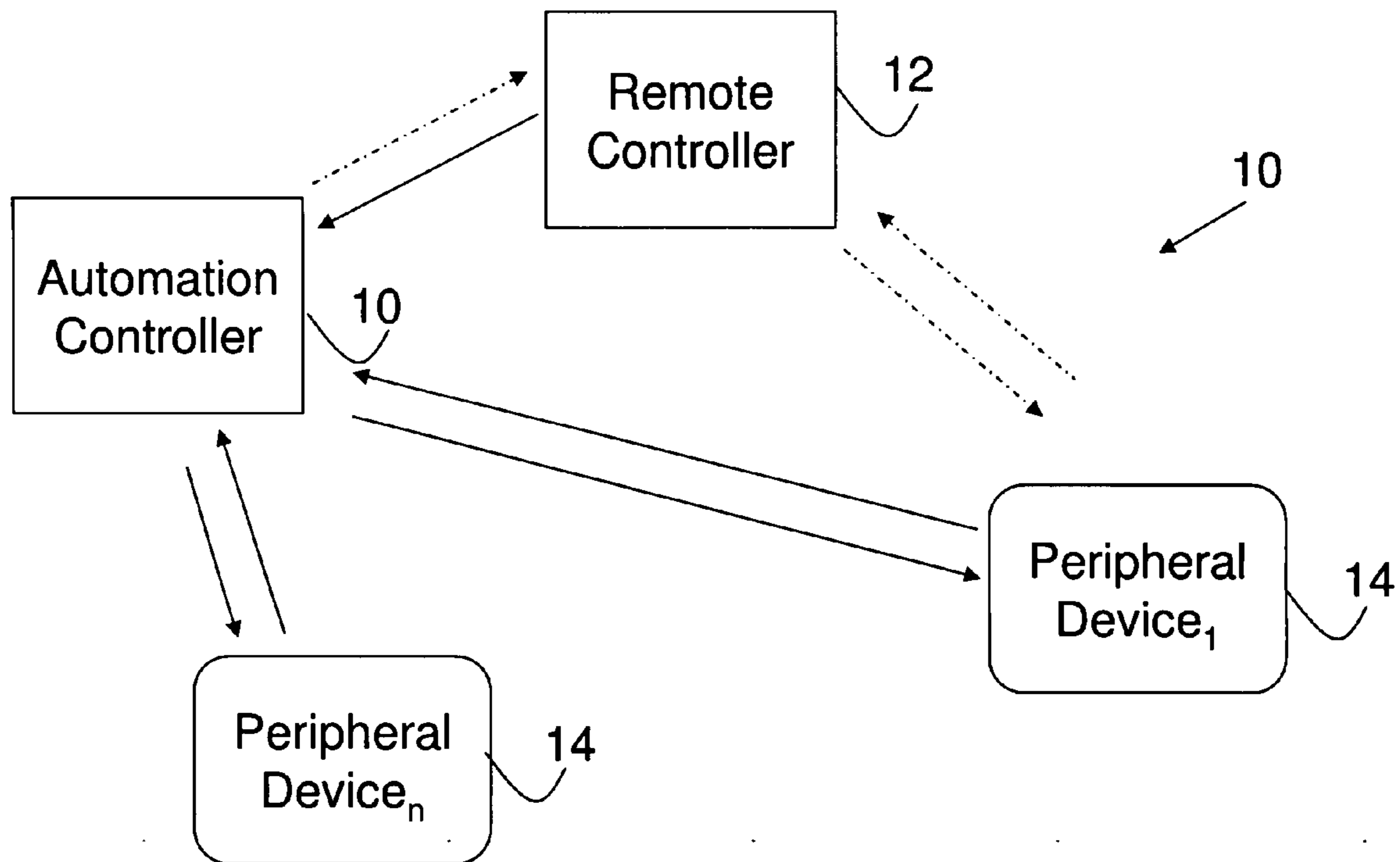

Fig. 1

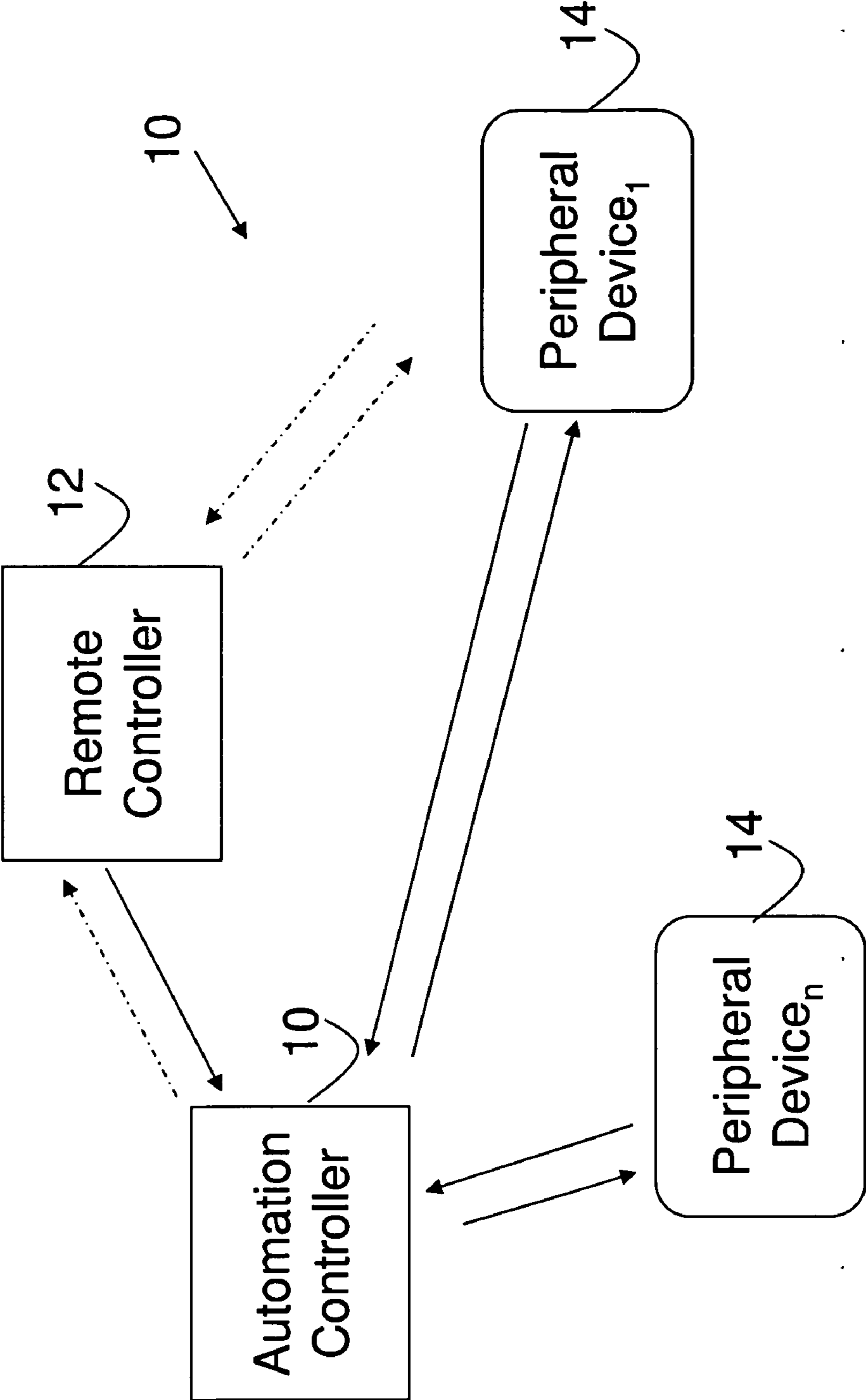

Fig. 2

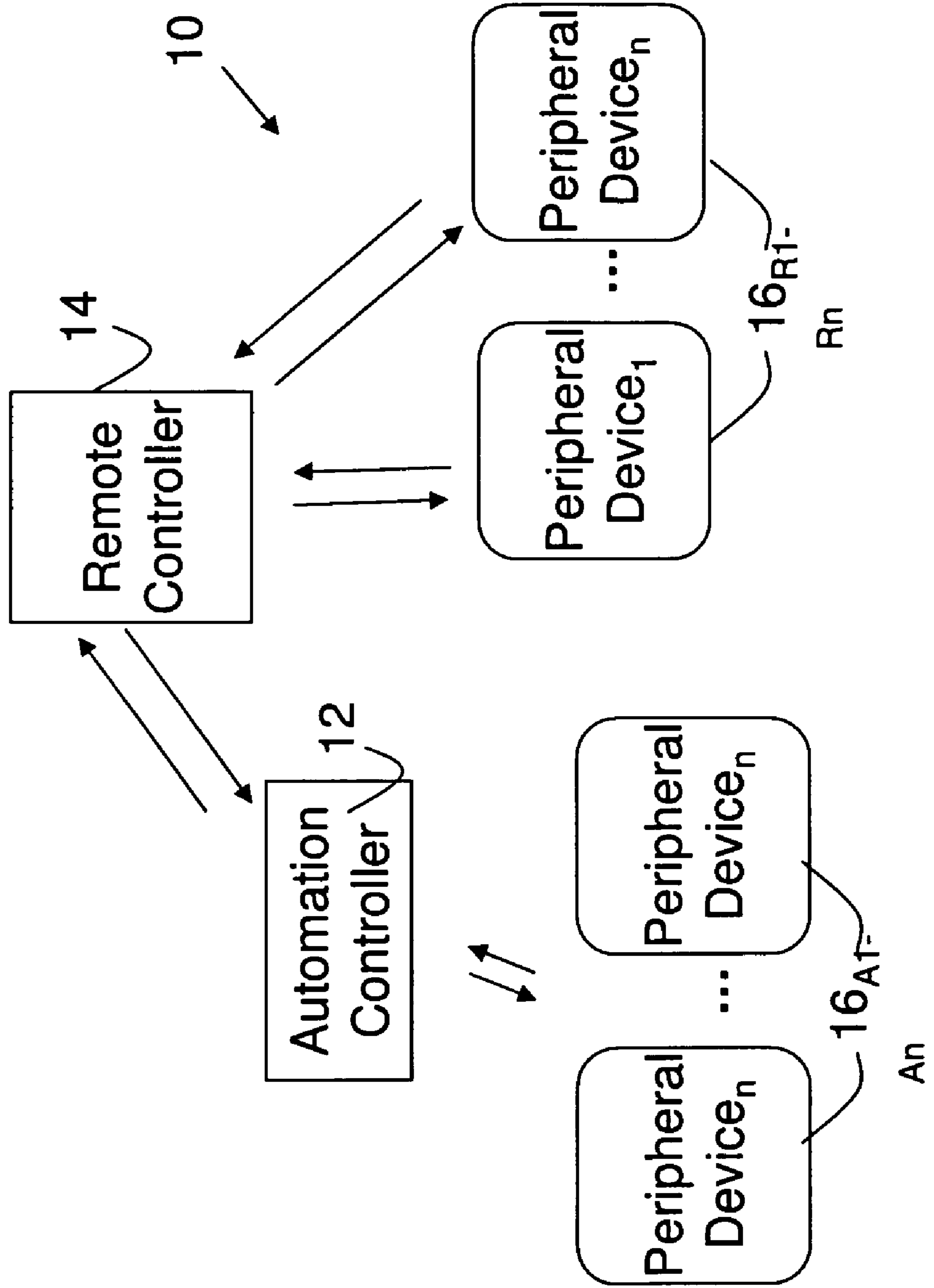

Fig. 3

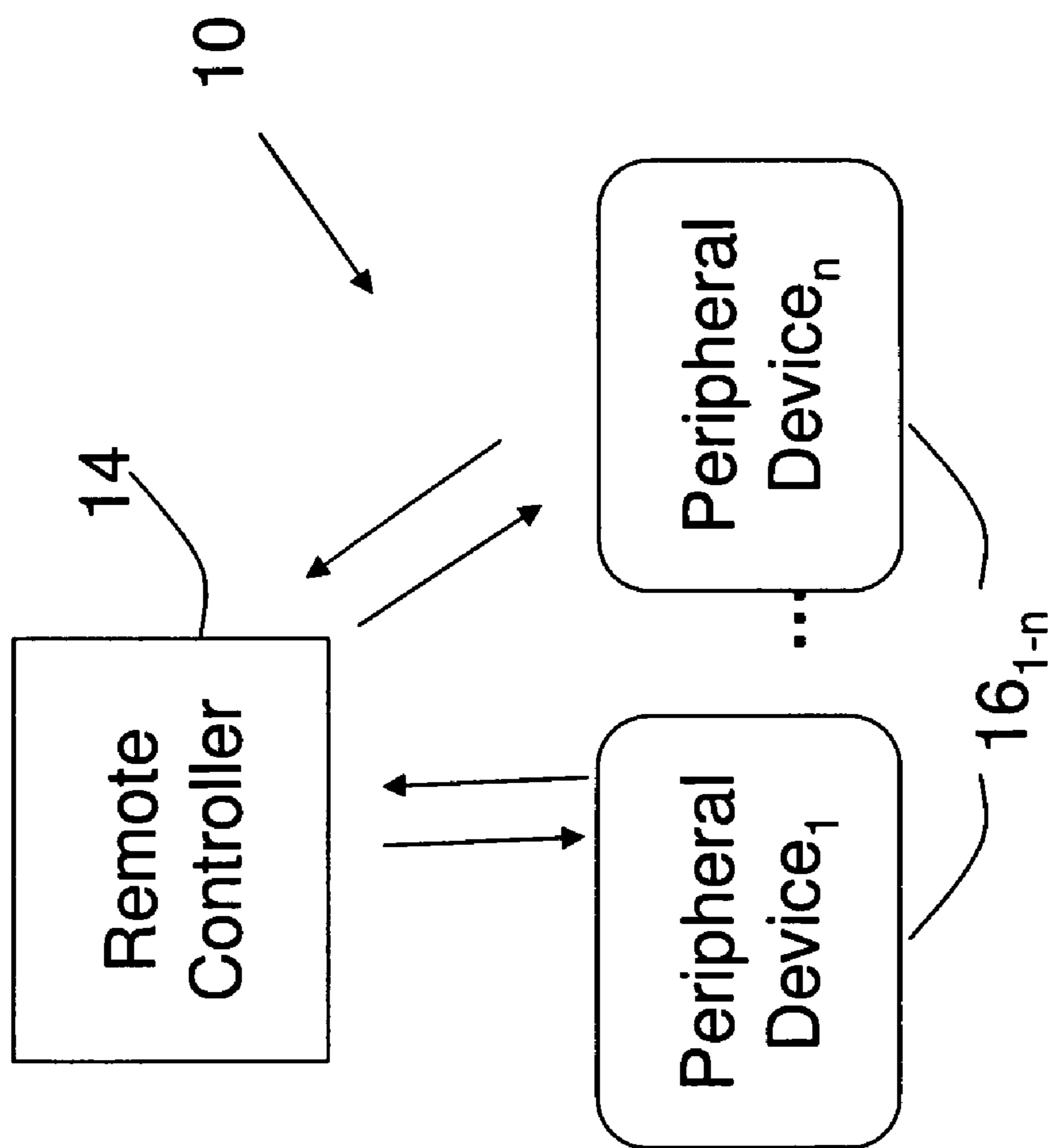
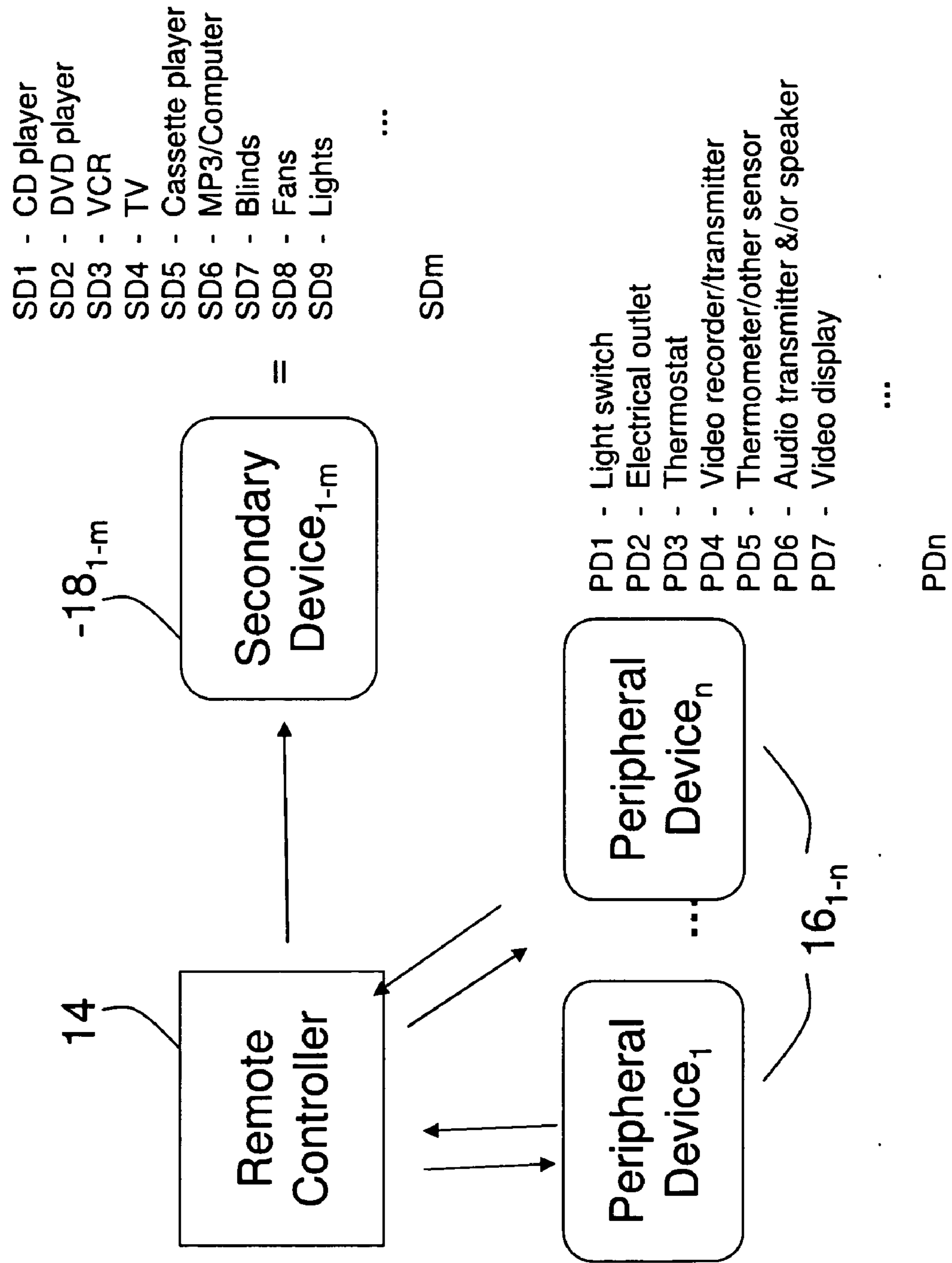

Fig. 4



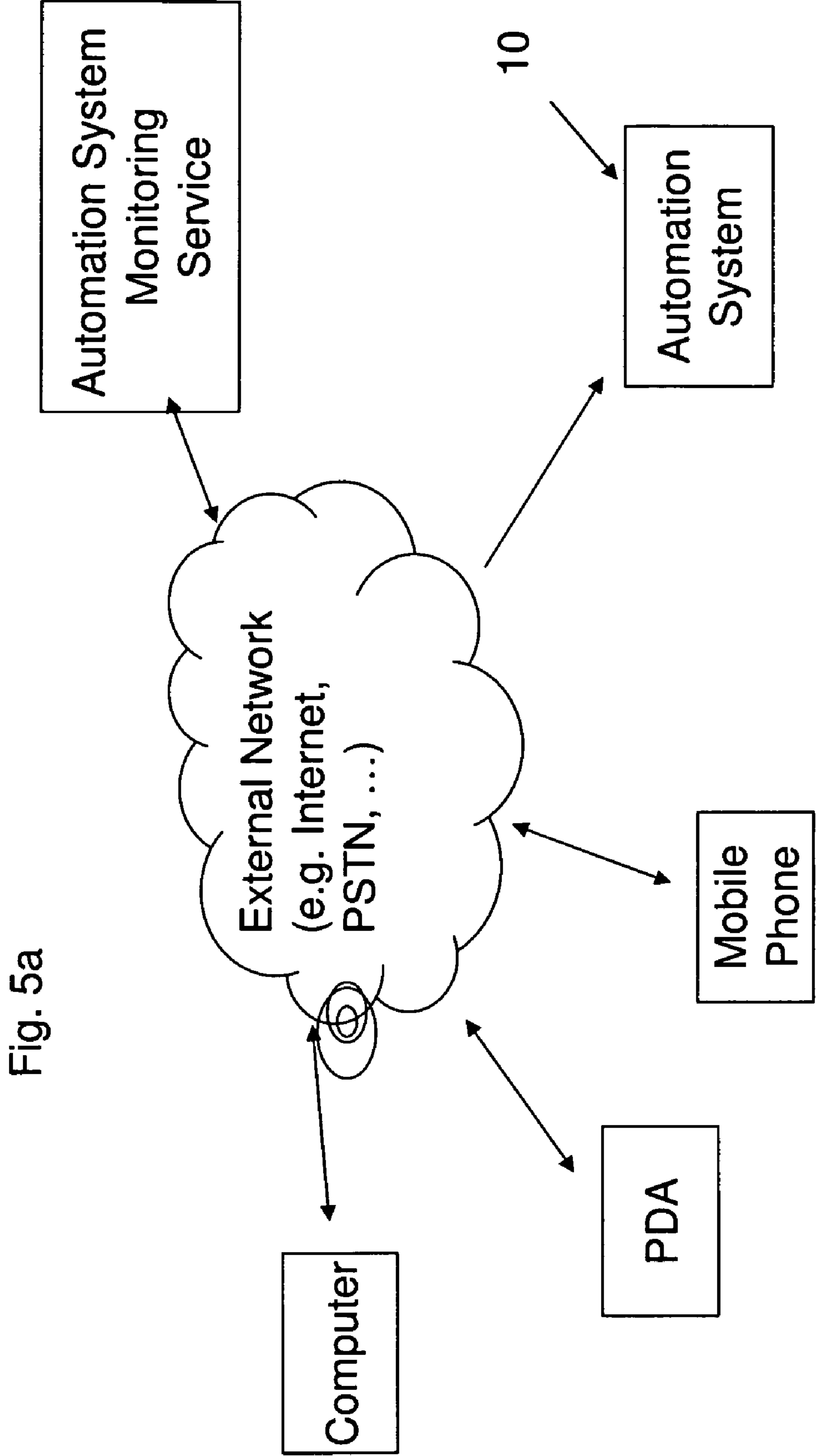

Fig. 5a

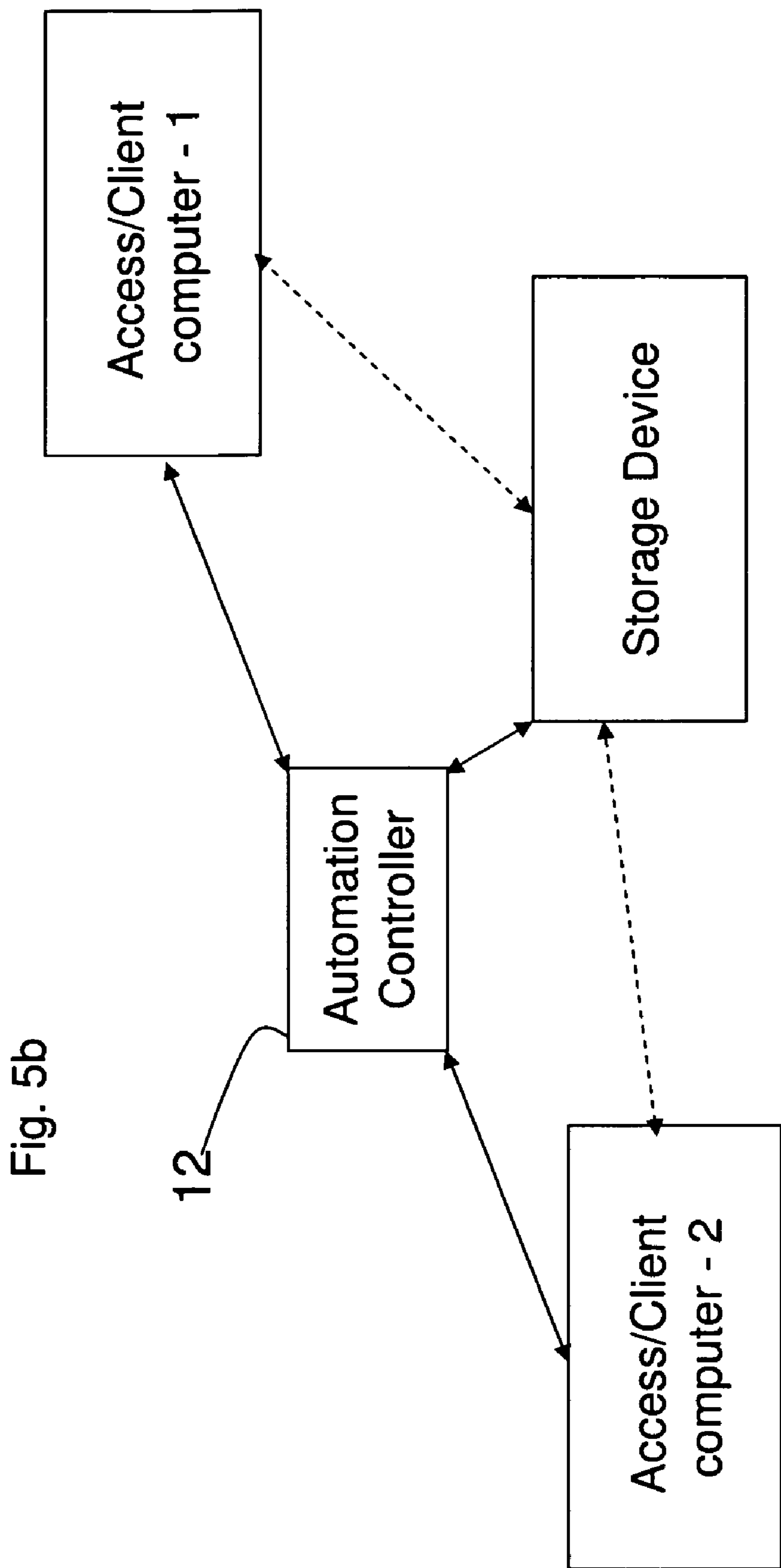
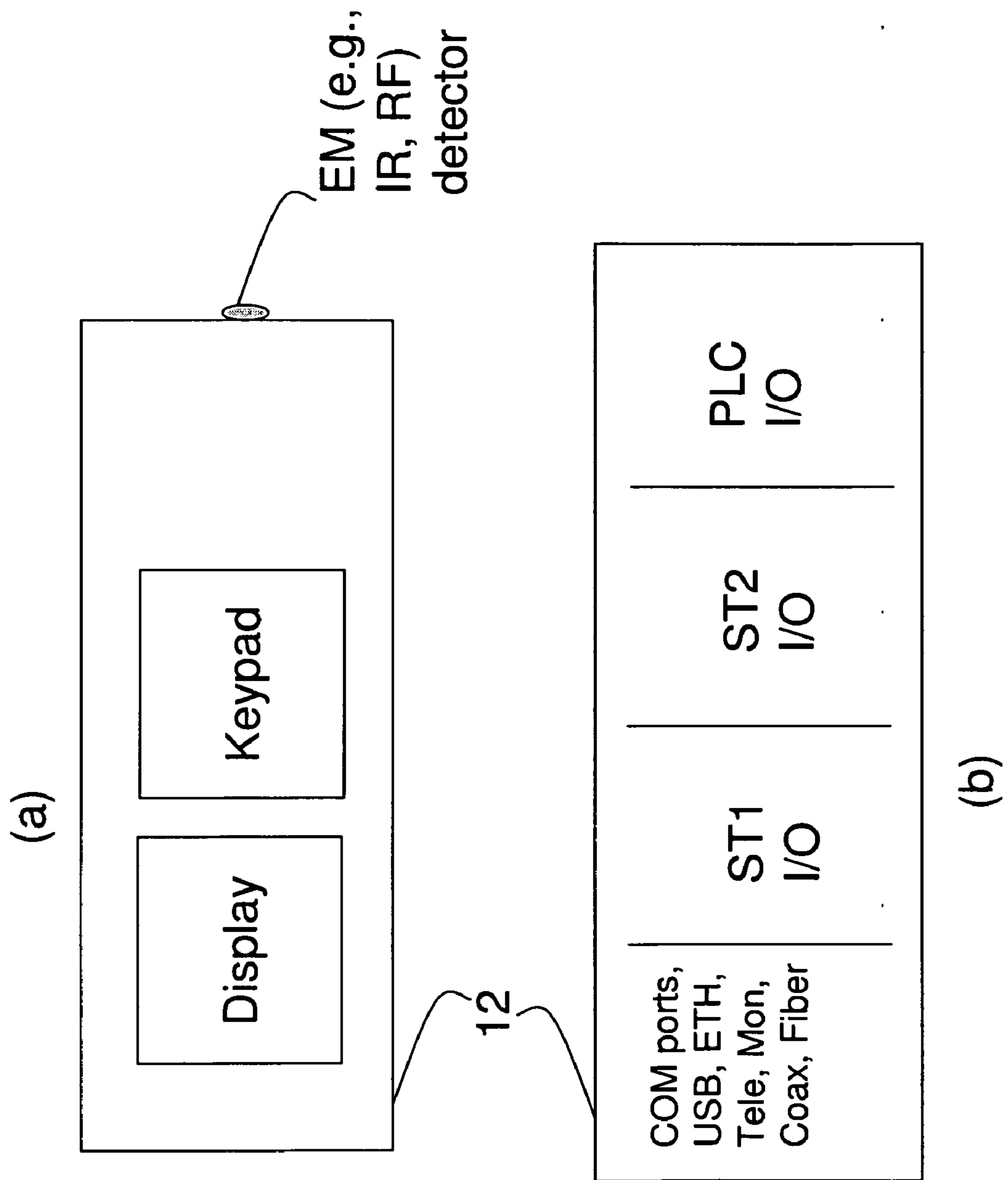

Fig. 5b

Fig. 6



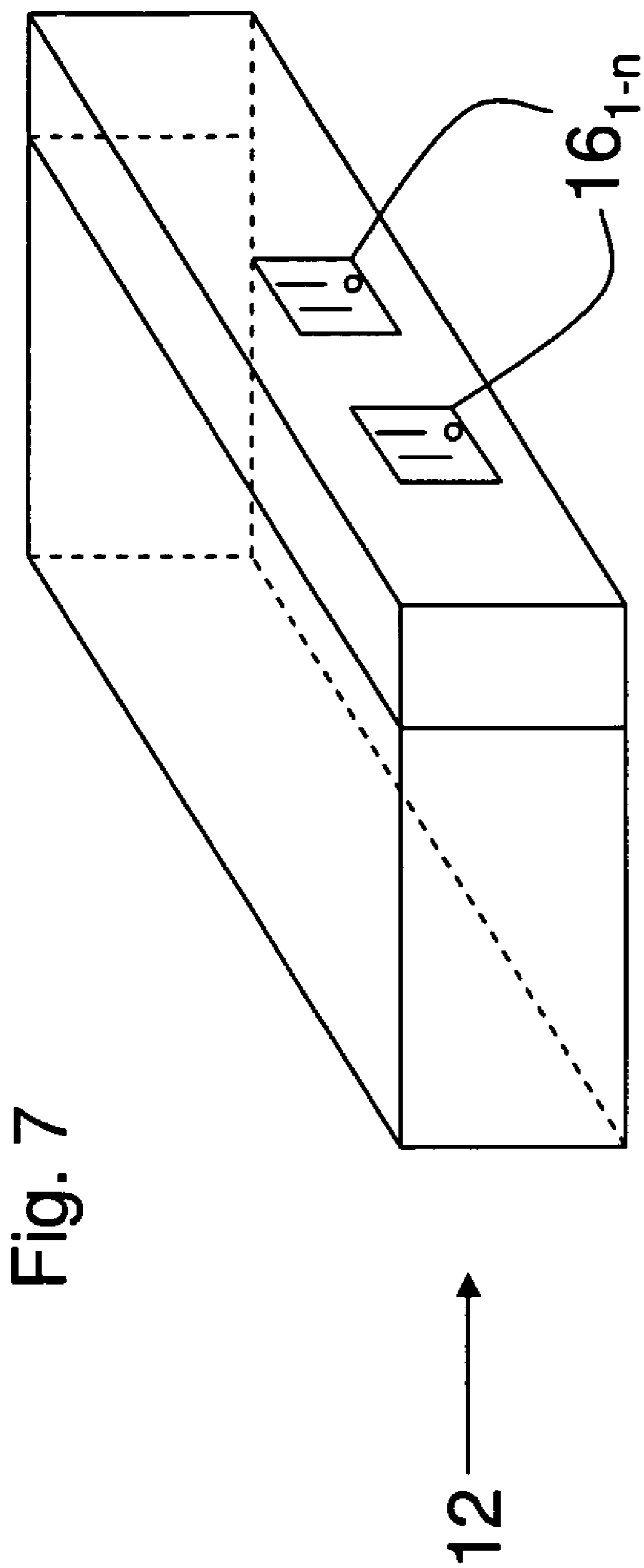

Fig. 8a

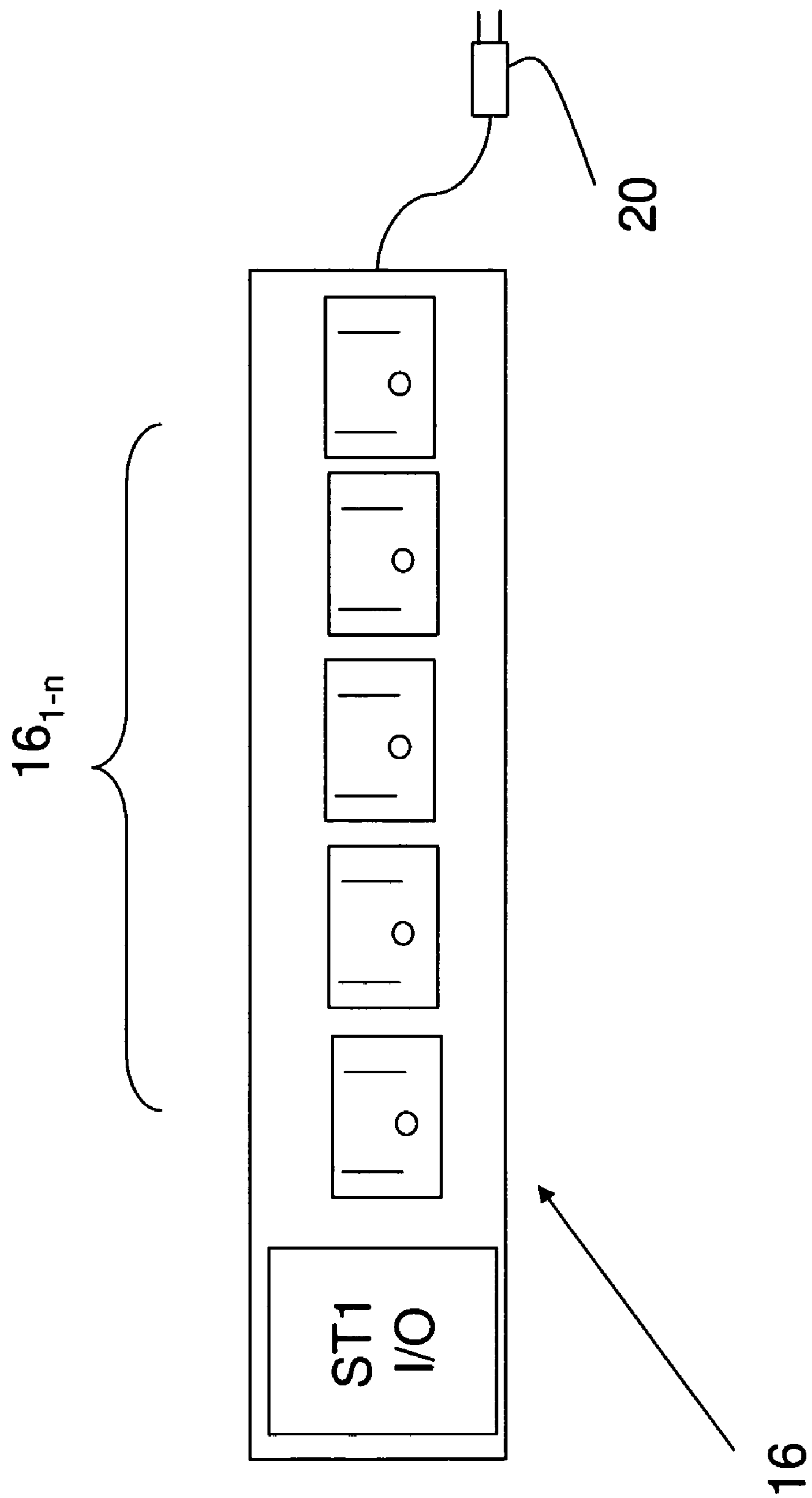
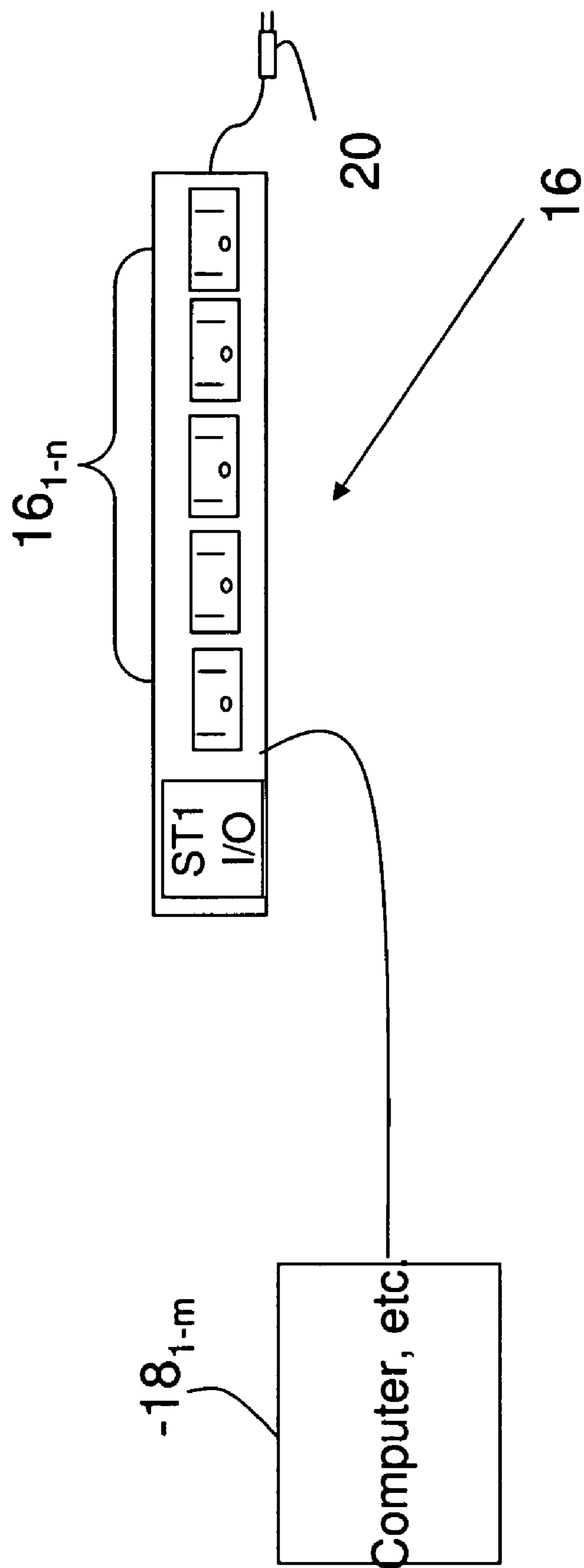

Fig. 8b



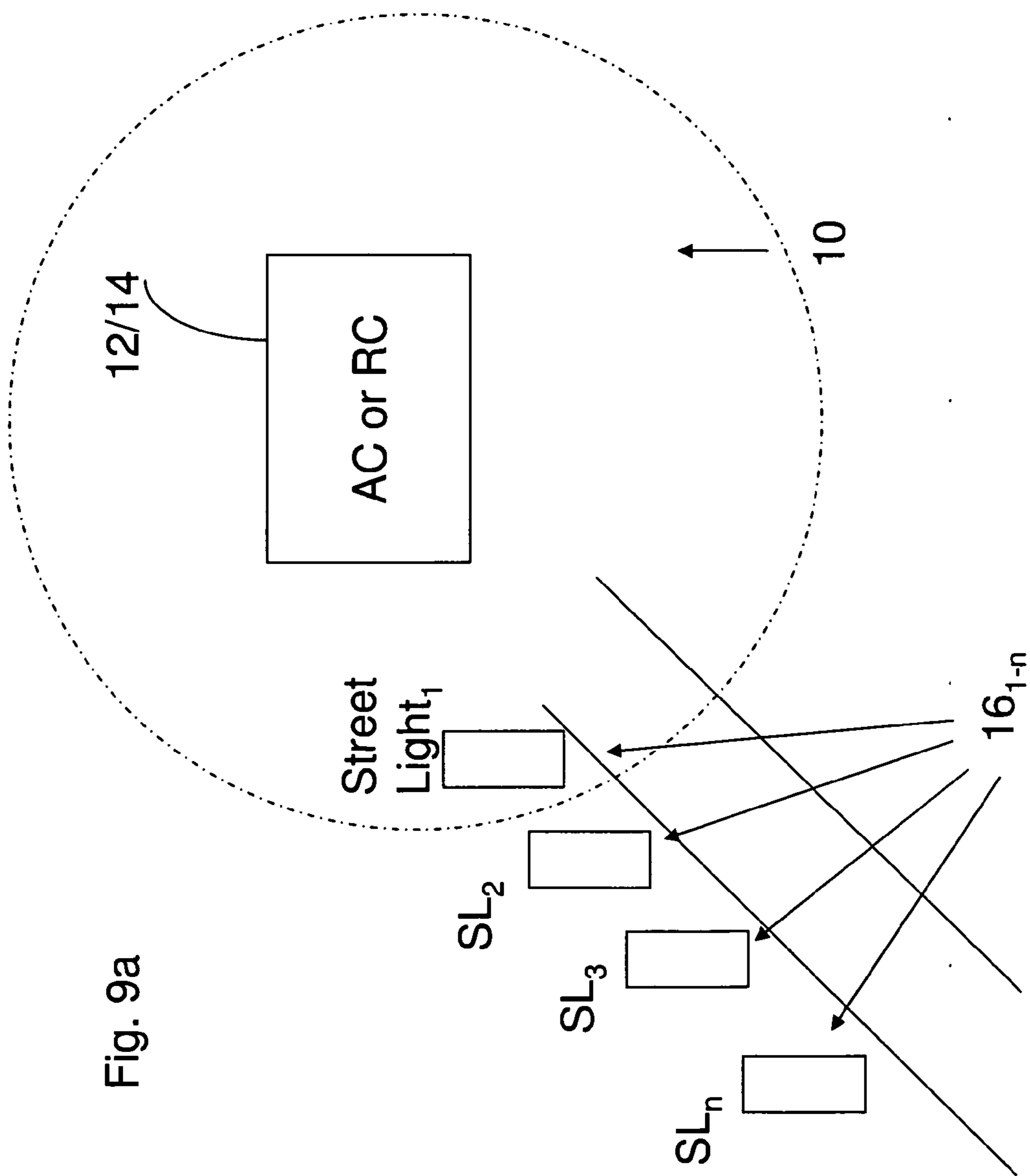

Fig. 9a

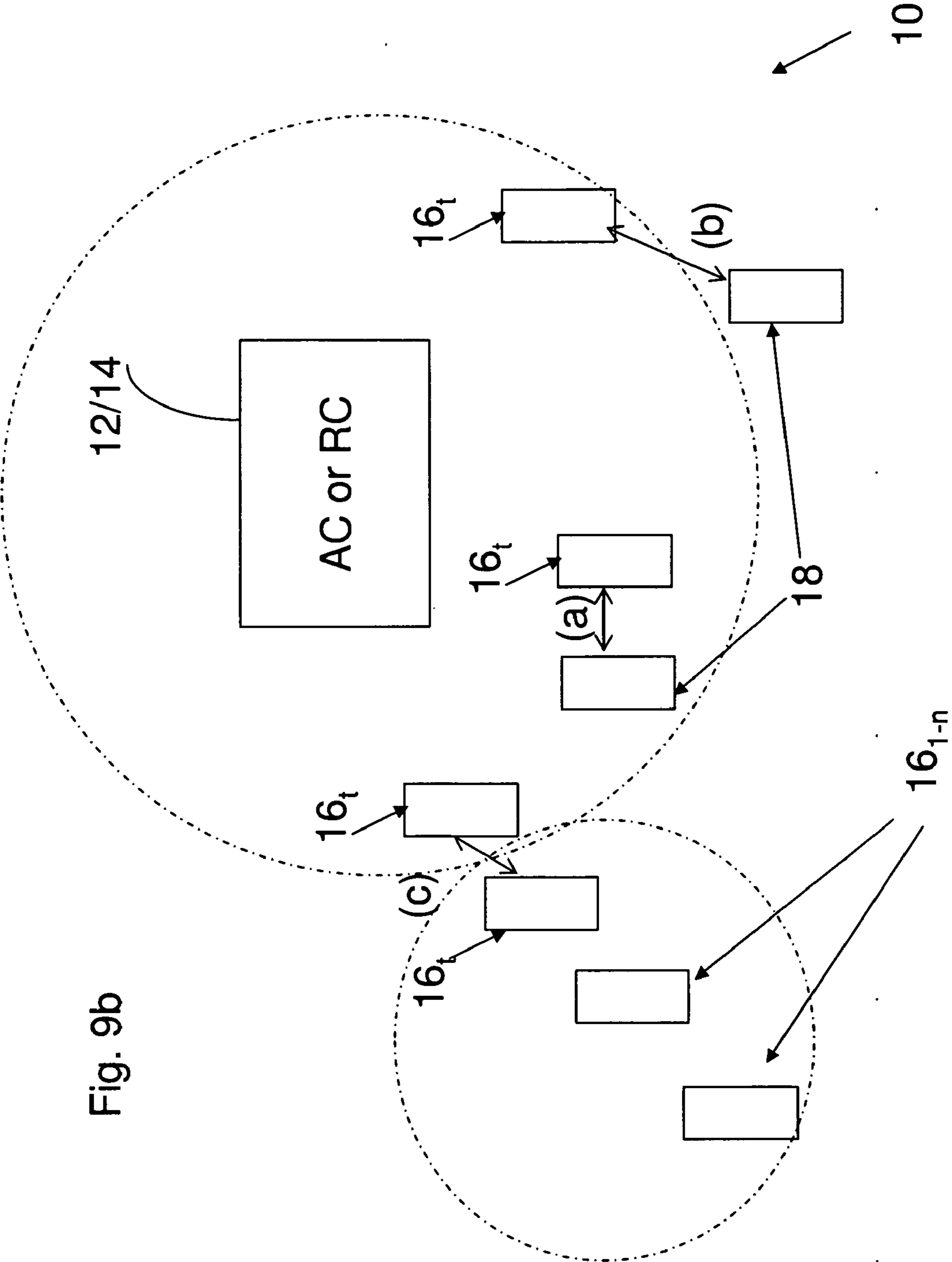
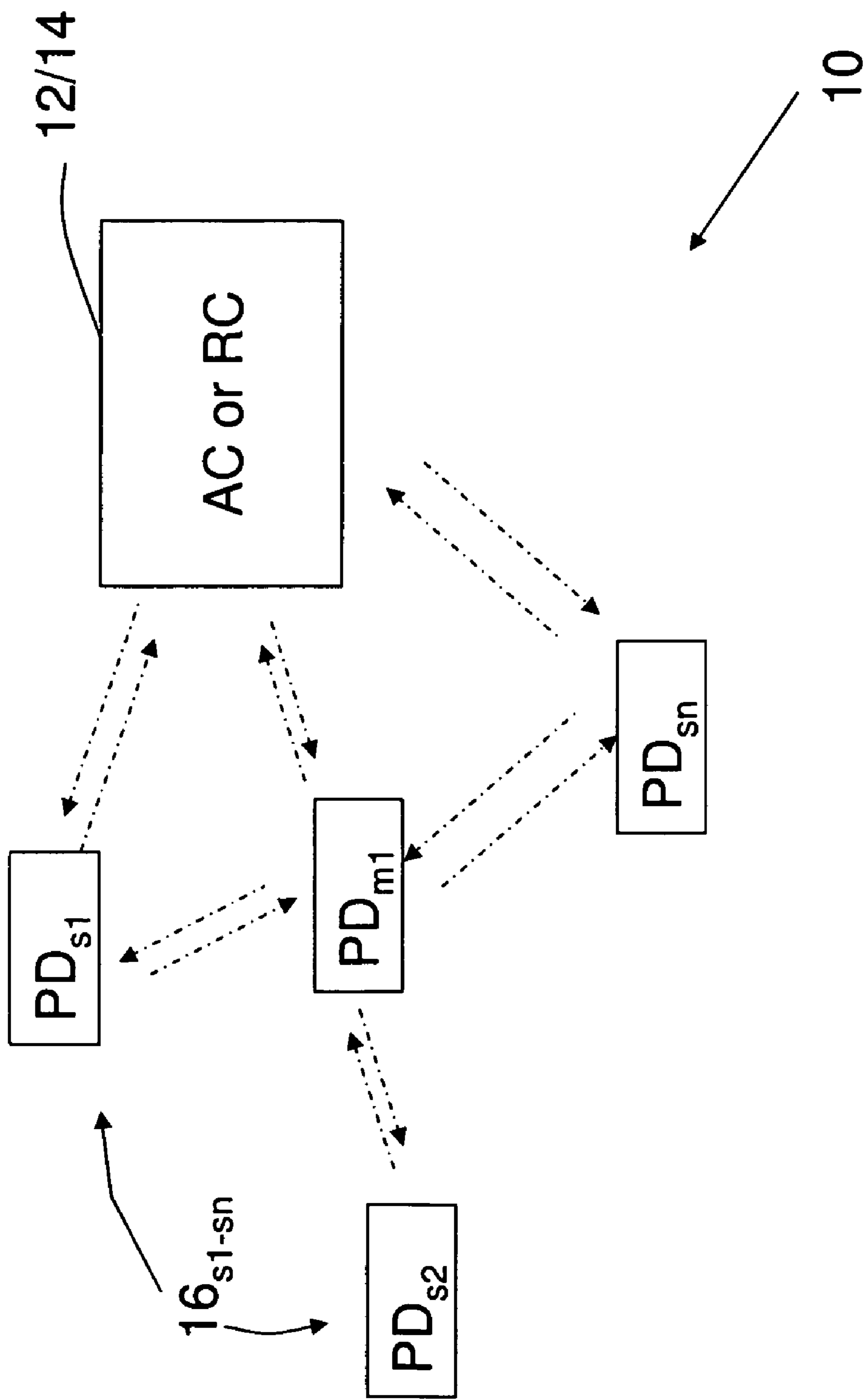

Fig. 9b

Fig. 10a



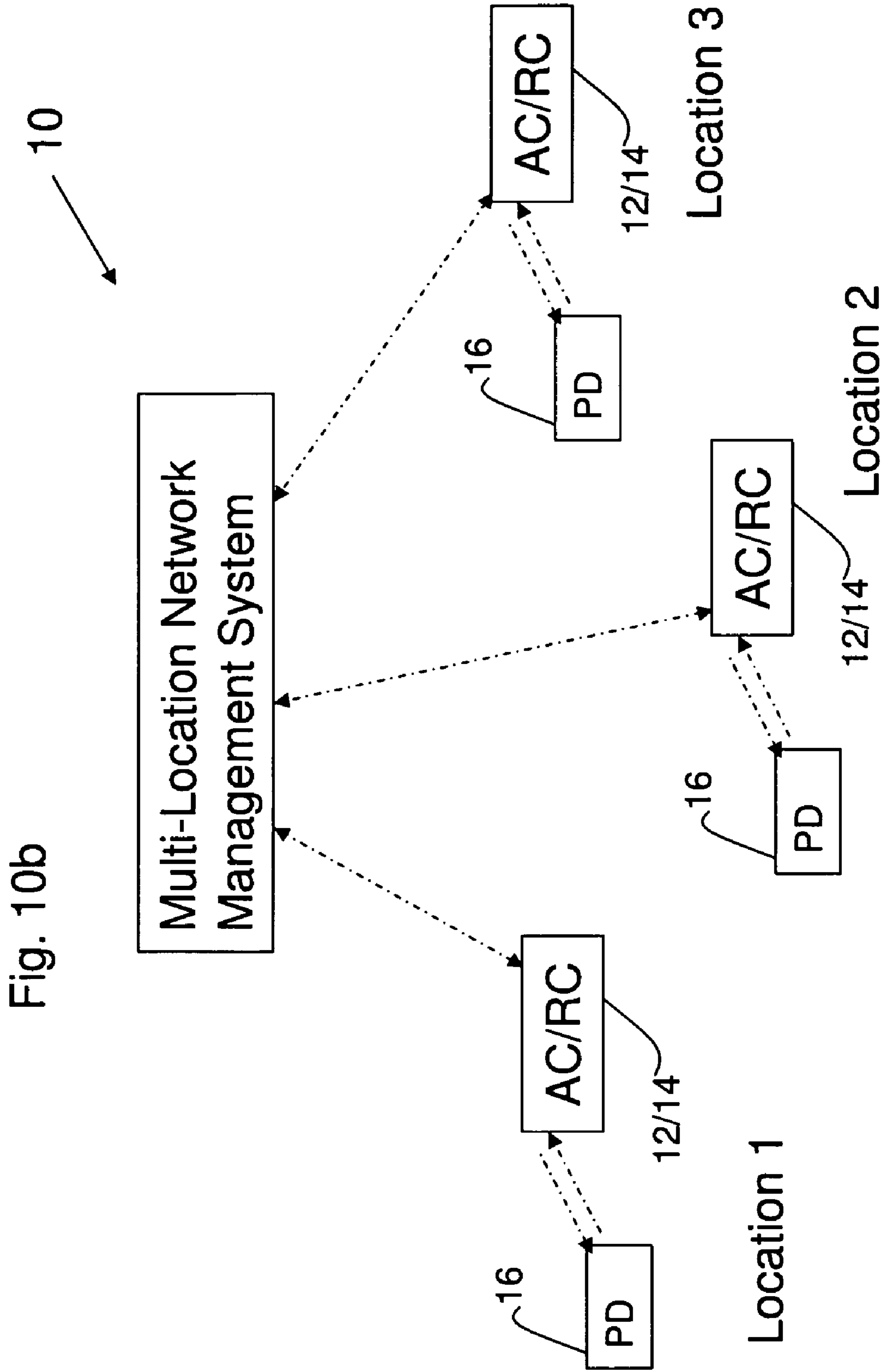

Fig. 10b

Front View

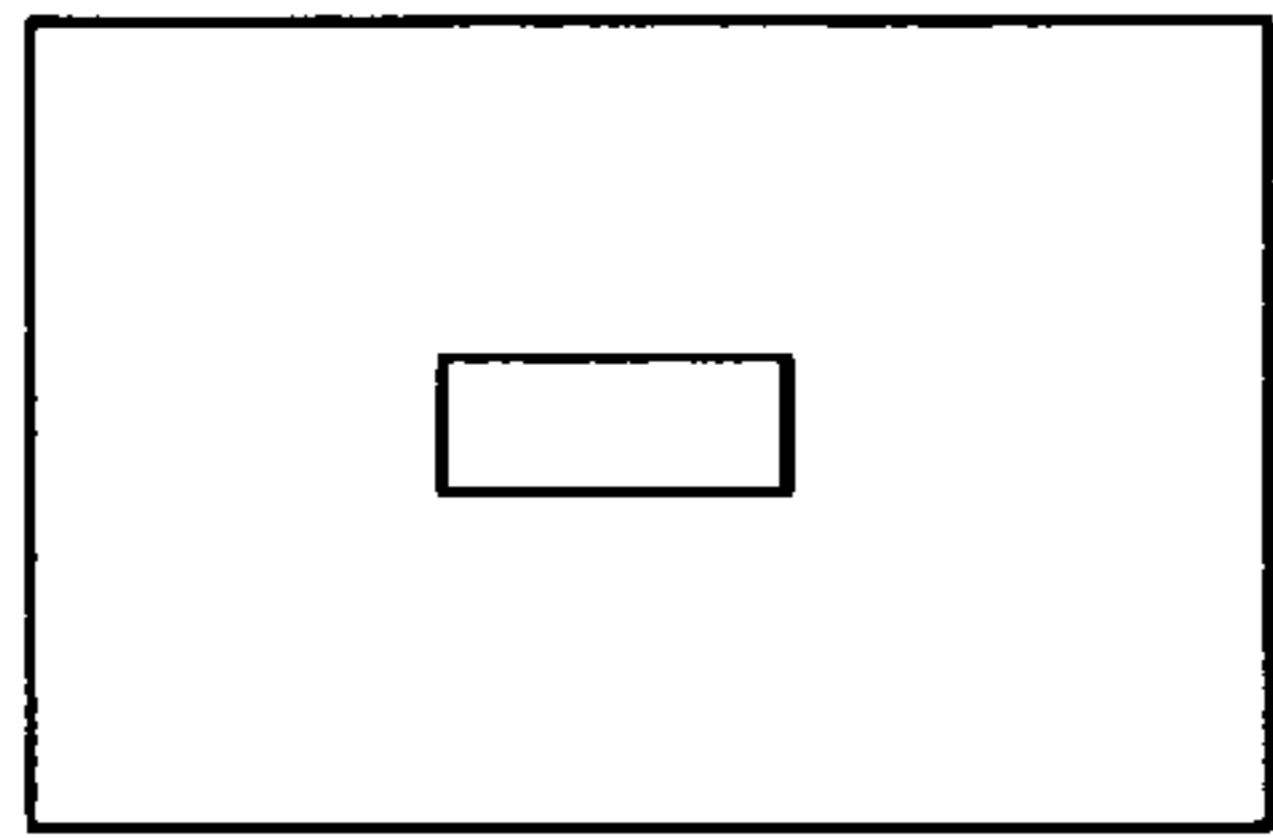

Fig 11

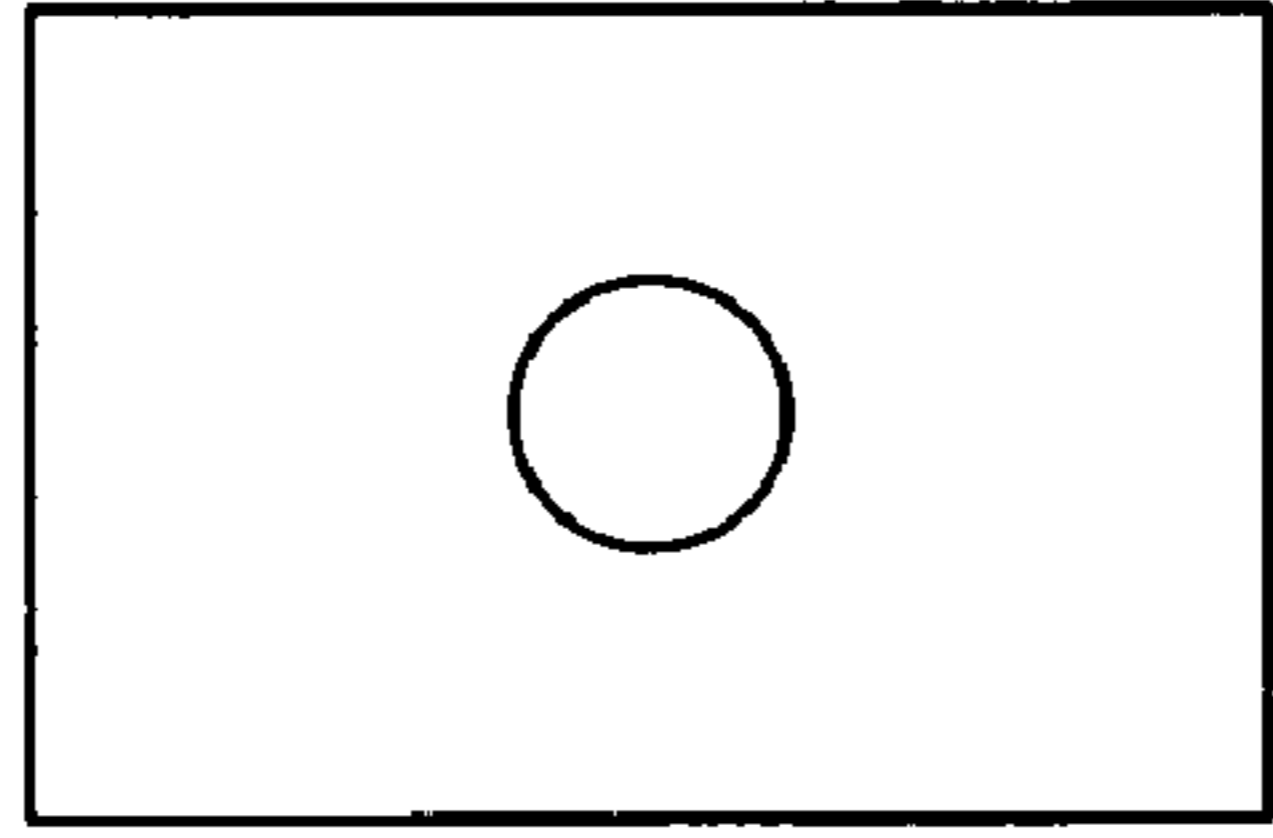

Fig 12

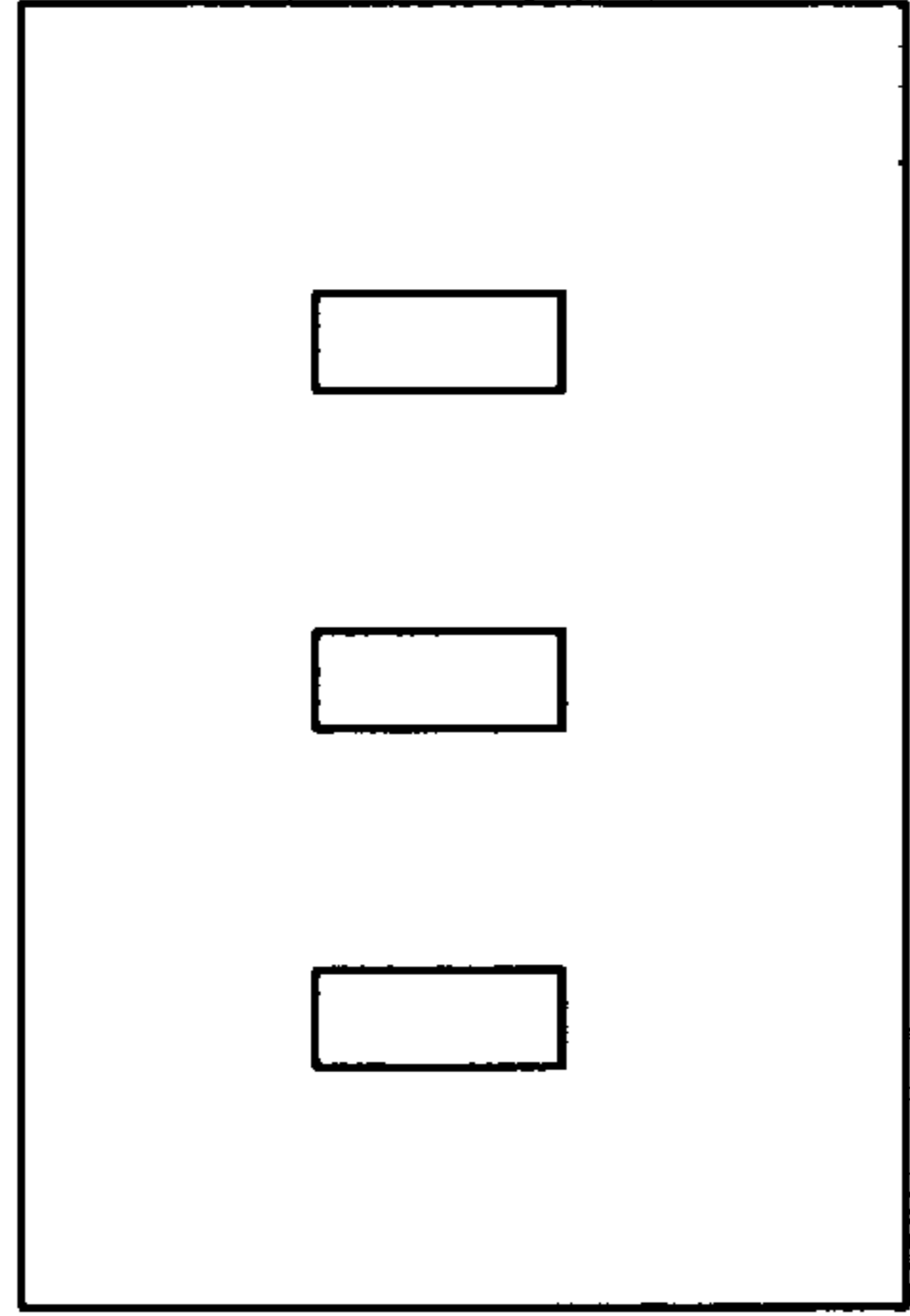

Fig 13

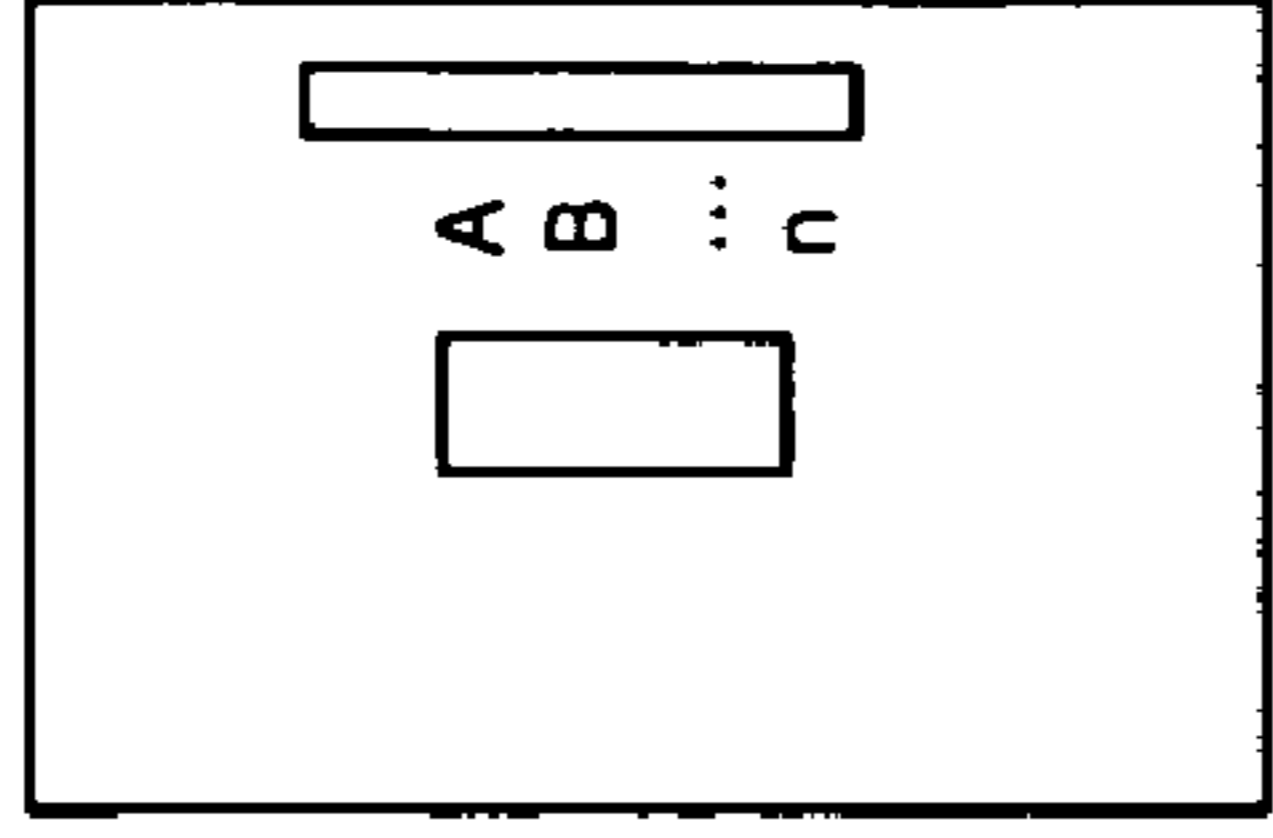

Fig 14

Side View

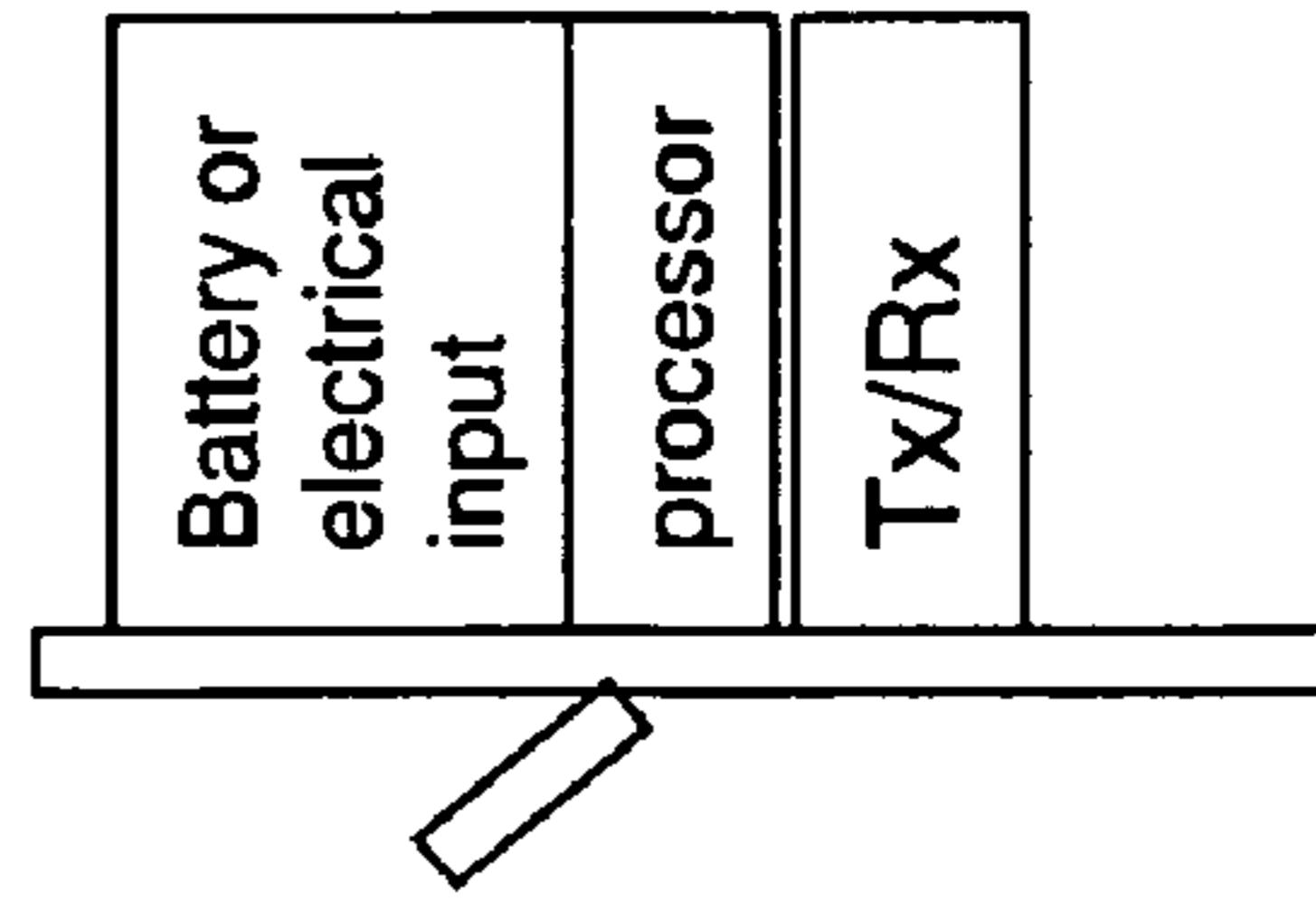

Fig 15

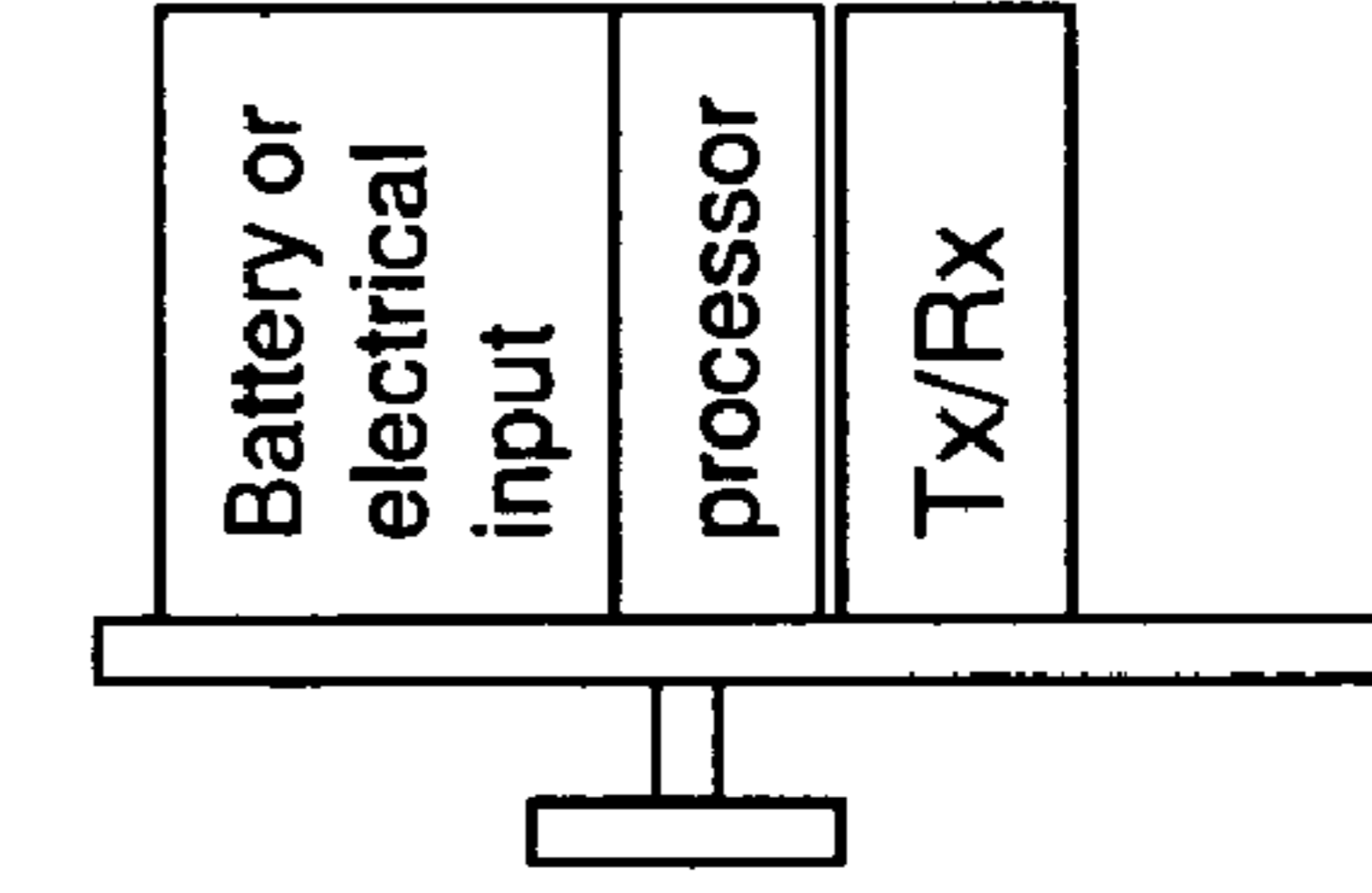

Fig 16

**UPGRADEABLE AUTOMATION DEVICES,
SYSTEMS, ARCHITECTURES, AND
METHODS**

CROSS-REFERENCE TO RELATED
APPLICATIONS

[0001] This application claims the benefit of U.S. Provisional Patent Application No. 60/886,918 filed Jan. 26, 2007 and is related to U.S. Patent Application entitled "Upgradeable Automation Devices, Systems, Architectures, and Methods for Energy Management" filed on even date herewith having attorney docket number 20070126B.

STATEMENT REGARDING
FEDERALLY-SPONSORED RESEARCH AND
DEVELOPMENT

[0002] Not Applicable.

FIELD OF THE INVENTION

[0003] The present invention is directed generally to automation systems and, more specifically, to automation systems to monitor and control conditions in and/or around buildings and the operation of energy systems.

BACKGROUND OF THE INVENTION

[0004] Automation of the work and leisure environment has been a concept that has been long pursued. Despite the continued pursuit, widespread automation, particularly in the home, has not gone much beyond the use of timers, programmable thermostats, and universal remote controls for audio and video equipment.

[0005] In the home, higher levels of automation have been left to the domain of the hobbyist and high net worth individuals. A major reason being that home automation systems tend to be difficult to implement and maintain and/or extremely expensive relative to the utility and benefits of the system. Also, the solutions tend to be one size fits all, where the benefits associated with the systems are realized with large system deployments, irrespective of whether a person wants to automate an individual socket, a room, or an entire facility.

[0006] X10 has been the most widely implemented protocol in the home automation industry. X10 is a low-speed, unidirectional PowerLine Communication/Carrier (PLC) solution that uses a home electrical power wiring to communicate with various devices that control the various functions in the home, such as light switches, wall receptacles, thermostats, etc. Common criticisms of X10 are directed toward its reliability and robustness, as well as the level of user-friendliness. As such, these systems have been left to hobbyist and those people willing to pay professional contractors to install and/or maintain the systems. Other PLC protocols have been developed to address the criticisms of X10, which have enhanced performance and user experience, but have not substantially broadened the market for these products.

[0007] The high-end of the residential market has typically been addressed by comprehensive and expensive stand-alone systems, which often require the use of professional services firms to install and possibly maintain the system. These systems can be integrated with other systems, such as security and intercom systems, to defray the cost of system ownership. In addition to the price of the comprehensive system, the cost

and inconvenience associated with providing an infrastructure to support these systems in existing structures has further constrained the market.

[0008] The emergence of wireless communication technology and digital media has reinvigorated the automation market, particularly the home market. New wireless protocols and standards are being developed and adopted to support wireless automation systems. The wireless systems are not constrained by power lines and do not require expensive wiring to build out a separate communication network or retrofit an existing structure.

[0009] Currently, there are two emerging protocols being introduced in the 1st generation of standard wireless automation products, namely Zigbee and Z-Wave. Both protocols attempt to provide a wireless networking standard that supports low data rates, low power consumption, security and reliability. Zigbee is open standard based on IEEE 802.15.4, while Z-Wave is a proprietary standard developed by Zensys, Inc., the current sole source for the chips that implement the protocol.

[0010] Many of the high-end automation system vendors have developed media center systems for the distribution and control of audio and video signals throughout the structure, which also include some home automation functionality. The media center provides control over various automation devices deployed in the structure and typically be accessed locally by a computer or remotely via the Internet. A universal remote control is typically provided, which communicates with the media center, which, in turn, communicates with the audio, video, and automation devices.

[0011] Other products employ a gateway controller that is controlled from a remote network operations center ("NOC") via a network connection into the structure. The gateway controller controls devices in the structure based on information provided by the NOC and provide status information to the NOC. A remote control is provided to allow for control of the individual automation devices without having to reprogram the device through the NOC.

[0012] Outside the home in non-residential settings, whether it is for or non-profit, academic, governmental, social, etc., owners and tenants face challenges similar to those in the residential market. Non-residential energy consumers can employ highly sophisticated systems for controlling their heating, ventilation, and air conditioning ("HVAC"), as well as for access control and information technology. Otherwise, these consumers are also generally limited to the use of programmable thermostats and motion controlled lighting.

[0013] As such, most energy consumers have little visibility into their energy consumption patterns. The lack of visibility makes it difficult to modify or tailor consumption patterns to reduce the energy consumed or the cost of the energy being consumed. Furthermore, participation in utility based conservation programs, such as demand-response programs, is typically limited to those residential and non-residential facilities that can operate with periodic interruptions of their air conditioning systems.

[0014] Improved automation solutions are required that overcome the various limitations associated with prior art solutions to enable high quality, cost effective, and scalable

automation solutions for homes and businesses that can be applied by the end users to their particular automation needs.

BRIEF SUMMARY OF THE INVENTION

[0015] The present invention provides, among other things, a scalable automation system that can be deployed as one or more independent systems at various times, which can later be consolidated and operated by a centralized automation controller either as independent systems or as one consolidated system. Unlike the prior art, the automation system of the present invention implements a hierarchical approach to the control platform that provides the end users with a wide range of implementation schemes allowing systems embodying the present invention to be tailored to the specific application and purpose of the user. The present invention can be implemented using various wireline communication platforms, e.g., powerline, twisted pair, coax, and fiber, and protocols, as well as wireless technologies employing Zigbee, Z-wave, Bluetooth, and/or other proprietary and/or open standard, e.g., IEEE 802.x, communication protocols.

[0016] In the present invention, automation components generally can be grouped into three different types, automation controller, remote controller, and peripheral, or controlled, device (or “peripherals”), which have different roles in the system, such as master or command (command a function be performed), slave or function (perform a function), and peer (master or slave depending on function). Notably, in the present invention, different component types can provide command functionality, as well as perform multiple roles at one time or different times, which provides significant benefits from an implementation standpoint, as will be discussed herein. Generally, the automation and remote controllers are peers from at least an interface perspective. The controllers are generally masters of the peripherals, making the peripherals slaves to the controllers, and the peripherals are generally peers to other peripherals.

[0017] Peripheral devices in the present invention are generally implemented in a function role communicating directly with remote controllers and/or automation controllers depending upon the system configuration and responding to their commands to perform a function, which may include one or more steps, process, and/or actions. For example, in the absence of an automation controller, the remote controller will be used to communicate directly with and control peripheral devices. Common peripheral devices include electrical wall and device receptacles and jacks, on/off, contact, and dimmer switches, visual (e.g., motion), audio, material (smoke, humidity, CO₂, etc.), electromagnetic wave (RF, IR, UV, etc.), and thermal sensors, thermostats, video equipment (e.g., cameras), audio equipment (e.g., microphones, speakers), computer and other office equipment and peripherals, etc.

[0018] Automation controllers are generally command components. While in many embodiments the automation controller may only serve in a command role, various configurations could implement automation controllers with in a function role, in lieu of, or in addition to the command role. For example, while in most applications it would be expected that the automation controller would be capable of controlling all of the peripheral devices in the system; it may be desirable to incorporate multiple automation controllers into the system to provide additional functionality at various points in the building that is being automated. Also, if the automation controller includes web browsing capability,

video signal reception, communication equipment hook-up, etc., it may be desirable to have an automation controller deployed at a number of locations within the building, in lieu of a computer and a traditional television set top box. It may, in turn, be desirable to control all of the automation controllers from one or more centralized automation controllers.

[0019] Remote controllers in the present invention can serve as command or function components assuming a master, slave, or peer role depending upon the system configuration and functionality. For example, in various embodiments, the system will be installed with only a remote controller and one or more peripheral devices. In these embodiments, the remote controller will provide command authority and control over the operation of the peripheral devices. In various embodiments, when an automation controller is introduced into a system having only peripheral devices controlled by a remote controller, the automation controller may assume command authority over some or all of the peripheral devices, with the remote controller assuming a command role with respect to the automation controller for those peripheral devices that were assumed.

[0020] It will be appreciated that different types of remote controllers can be employed in the present invention. For example, one type of remote controller may be able to provide command and/or slave functionality, while a second type of remote control may be able to serve solely to send commands to the automation controller, e.g., a standard remote control. It will be further appreciated that the different types of remote controllers may enable different levels of functionality and feedback to the user.

[0021] In addition, the remote controller can incorporate functionality that allows it to operate in multiple systems. For example, either type of remote controller can also serve as a “universal remote” controlling devices other than the automation peripheral devices. For example, the remote controller may be a master and/or peer in a home automation system communicating using the Zigbee and/or Z-wave protocols or other open or proprietary standard protocols with automation controllers and/or peripheral devices, while also supporting infrared (IR) or radio frequency (RF) signal transmission for line of sight (LOS) and/or non-line of sight (NLOS) control of audio and/or video equipment, such as TVs, DVD and CD players/recorders, DVRs, PVRs, and VCRs.

[0022] In various embodiments of the present invention, the system may be in operation without an automation controller using the remote controller to control a plurality of peripheral devices. In these embodiments, the remote controller recognizes that there is not an associated automation controller, so it operates in the first state, directly communicating with and controlling the peripheral devices. When the end user of the system introduces an automation controller into the system, the remote controller recognizes the automation controller and operates in a second state communicating with the automation controller, instead of directly with the peripheral devices. If the associated automation controller becomes unassociated with the remote controller, then the remote controller will revert to the first state and control the peripheral devices directly.

[0023] The automation controller and a remote controller can provide different levels of control and functionality to the system. The remote controller, for example, may generally be able to control the on/off/dim state of a limited number of peripheral devices and provide some level of feedback, which will depend upon the type of remote controller, e.g., whether

or not it has a display. In an exemplary embodiment, the remote controller does not have a display, but depicts the on/off/dim state of the peripheral device by lighting the key associated with that device. Alternatively, display remotes, remote monitors, or touch pads can provide individual device status displays or a device list that can be scrolled. The displays and touch pad can be integrated in the remote controller or separate components that communicate with the remote controller directly or indirectly. The remote controller may be configured to provide device status, irrespective of whether it provides direct or indirect control of a peripheral device.

[0024] In various embodiments, the system is operated using only the automation controller and the peripherals without a remote controller. In these embodiments, the automation controller will be accessible via one or more interfaces. For example, a display and data entry facility provided directly on the controller, a television or other monitor can be used for display with data entry on the controller or via an external device, such as a keyboard, etc. Other devices, such as computers, can be used to access the automation controller for the purposes of data access and input. Other computers can be configured in a client-server architecture with the controller for data access and entry. Alternatively, the controller functionality could be distributed among multiple controllers as discussed above.

[0025] Additional devices can be employed to provide additional functionality or robustness to the system. For example, storage devices could be employed to off-load data collected by the automation controller. Access to the storage devices could be achieved via the automation controller or directly by another computer, which can provide analysis capability off-line from the automation controller.

[0026] The automation controller can provide enhanced functionality concerning the automation system, such as Internet connectivity, remote monitoring (i.e., any computer, anywhere monitoring, advanced scheduling for peripheral devices (turn on different lights on different days of the week for security purposes), periodic and continual monitoring of peripheral devices (confirm children's light and TV are off), event correlation from peripheral device feedback (turn off lights if no one in the room for five minutes), peripheral device fault information (e.g., a light bulb burns out, so there is no current flow irrespective of the state of the peripheral device), event notification (e.g., email, text message, audible or visible signal, or electronically generated phone call, etc.), access control and monitoring to one or more parties concerning a detected event.

[0027] The automation controller can also provide additional functionality beyond the automation system. For example, it can provide a web interface for browsing or a control system for communication equipment used to provide services, such as plain old telephone service (POTS), voice over Internet Protocol (VoIP), video, audio, and data. In embodiments with sufficient computing and storage capacity, various software applications can be run and/or files can be stored and sent to/from the automation controller. Video applications can be included, such as video recording, audio/video broadcast or stream reception and codec functions. It could also provide modem, router, and/or switch capabilities, if desired.

[0028] Furthermore, the automation controller can be in a housing that includes one or more peripheral devices. For example, the automation controller housing can include one or more controlled electrical receptacles. Given that the auto-

mation controller will often times be located proximate other electrical equipment that can be controlled, the inclusion of peripheral devices within the automation controller housing provides a cost effective and space efficient solution. Communication between the automation controller and the peripheral devices within the housing probably is most cost effectively implemented via circuitry internal to the housing; however, the peripheral devices could employ a transceiver and communicate in the same manner as other peripheral devices.

[0029] In addition, there does not necessarily need to be a one-to-one correspondence between the number of peripheral device transceivers for communicating with the controllers and the number of electrical devices being controlled. For example, electrical wall outlets typically have two receptacles per outlet. In the prior art, each receptacle is considered a different controlled device. In the present invention, the wall outlet can be considered one peripheral device with each receptacle being a sub-device. Both receptacles communicate with the controller via a common transceiver. One of ordinary skill can expand this concept, for example, to provide a multi-receptacle, plug strip that shares a communication path (transceiver) to/from the controller.

[0030] Similar to the remote controller, the automation controller can employ integrated or external display capability. For example, the automation controller can be configured to display information on one or more television screens and/or computer monitors. Conversely, the automation controller may have an integrated display, which may or may not be a touch screen.

[0031] In various embodiments, the system includes both stationary and mobile peripheral devices. The mobile devices can be used for security and safety purposes, such as theft prevention and tracking the location of children and disabled adults, as well as pets and objects. The system detects the location of the mobile device periodically and/or on-demand and can employ information concerning the mobile device provided by stationary devices.

[0032] Also, the peripheral devices can be configured to communicate with other systems. For example, a peripheral device, such as a plug strip/surge protector, may include communication capability with a computer via USB cable or other connection. In these embodiments, the peripheral device could send a system message to the computer that power was going to be interrupted and for the computer to perform a graceful shutdown. It could also send a signal that initiates the booting up of the computer.

[0033] Embodiments of the present invention also may include a limited purpose remote controller ("LPRC"), which can be a wall mounted, free-standing, or handheld device. The LPRC can be embodied as a configurable on-off or dimmer switch that can be used to control one or more peripheral devices directly and/or via the automation controller or the remote controller. For example, the LPRC can be configured to control one light or one electrical receptacle in a room similar to a traditional light switch. Alternatively, the LPRC may be configured to control a group of lights and/or other peripheral devices. The LPRC is reconfigurable, such that the automation instruction created by the LPRC upon actuation can be varied as desired by the user. For example, the lighting configuration can be varied, if a room is rearranged and audio and video components can be added and subtracted from the control of the LPRC as desired.

[0034] The automation system can be deployed over a wide range of applications from providing basic automation and control functionality with individual peripherals in the home or workplace to orchestrating the operation of the peripherals to provide comprehensive energy, automation, and access management solution.

[0035] In various embodiments, the automation system will perform integrated energy management of part or all of a facility. For example, a user in a business setting may establish a multi-level energy management structure. At a first level, the user establishes day and time of day settings for the heating, ventilation, and air conditioning (“HVAC”) equipment/units and systems. Typically, this will involve setting a first temperature range for hours of operation and a second temperature range for hours of non-operation.

[0036] A second level of control may be implemented at the work space and common area level. For example, the temperature of a work space may be controlled depending upon whether or not a person is present at the facility or whether a meeting is scheduled or people are present in a workspace, such as a conference room.

[0037] The concept of controlling the temperature depending upon the presence of a person at the home or work place can be exceeded more generally to “just in time” energy management. In various embodiments, the automation controller provides access control and/or monitoring or interacts with an access control/monitor system and a person’s work space or part of a residence is not supplied electricity unless the person is present. Upon detection of a person entering a facility, the automation controller would turn on the supply of power to a person’s work space and adjust the temperature of the work space accordingly. In various embodiments, the automation controller could begin powering up computer equipment and peripherals, so the equipment is ready to use when a person’s reaches their work space. When a person leaves a work space, the automation can direct the return of the work space to its non-operational set points.

[0038] At another level, the automation controller can coordinate the different energy management activities within a facility and/or work space. For example, a work space environment will be defined at least in part by the temperature and lighting intensity. The automation controller can be configured to balance the solar impact, i.e., light and heat provided by sunlight, within an area with the light and heating/cooling provided by the building systems to minimize the energy cost and/or consumption. In this case, the automation controller could control various lights, HVAC vents and/or units, and window blinds in a coordinated manner to reduce energy consumption. Alternatively, the automation controller could interact with an area controller that could be coordinating the peripherals within an area. For example, the area controller could include or be associated with various sensors, such as temperature, light intensity, and motion, in the area, which provide local information used to control the area environment.

[0039] The present invention addresses limitations of the prior art as will become apparent from the specification and drawings.

BRIEF DESCRIPTION OF THE SEVERAL VIEWS OF THE DRAWING

[0040] The accompanying drawings are included for the purpose of exemplary illustration of various aspects of the present invention, and not for purposes of limiting the invention, wherein:

[0041] FIGS. 1-5*b* show embodiments of automation systems;

[0042] FIGS. 6*a*-7 show embodiments of automation controller;

[0043] FIGS. 8*a*-9*b* show embodiments of peripheral devices;

[0044] FIGS. 10*a*-*b* show embodiments of a system including at least one mobile peripheral device and,

[0045] FIGS. 11-16 show embodiments of LPRCs.

[0046] It will be appreciated that the implementations, features, etc. described with respect to embodiments in specific figures may be implemented with respect to other embodiments in other figures, unless expressly stated, or otherwise not possible.

DETAILED DESCRIPTION OF THE INVENTION

[0047] FIG. 1 depicts an automation system 10 embodiment of the present invention. The system 10 includes various components, such as an automation controller 12, a remote controller 14, and one or more peripheral devices 16_{1-n}. In this embodiment, the automation controller 12 has two way communications with the peripheral device 16 (as shown by the solid arrows). It also has at least one way communication with the remote controller 14, and, optionally two way communications with the remote controller 14 (as indicated by the dashed arrows). In addition, the remote controller 14 can have optional one or two way communications with one or more of the peripheral devices 16_{1-n}.

[0048] Communication between the automation controller 12 and the peripheral devices 16 can be wired and/or wireless depending upon the particular implementation. Wired communication can make use of the power lines, local area networks, or direct links between communication ports, such as USB, RS-232 and 485, etc. Wireless communications can employ one or more wireless technologies, such as Zigbee, Z-wave, Bluetooth, and/or other proprietary and/or open standard, e.g., IEEE 802.x, communication protocols transmitting signals in the infrared and/or radio frequency spectrum. As mentioned above, Zigbee and Z-wave are protocols that have been developed specifically for applications, such as automation, where some of the devices used in the system, such as those operating on battery power, may require low power, reliable, non-line of sight communication.

[0049] In embodiments such as FIG. 1, the automation controller 12 may serve as a peer or slave to the remote controller 14 depending upon the desired level of functionality and communication between the controllers. For example, when one way communication is provided from the remote controller 14, the automation controller 12 will act only as a slave performing an operation in response to a command/input from the remote controller 14. In embodiments providing for two way communication, the controllers may serve as peers or as a master and slave depending upon the configuration of the system 10. For example, if the only communication from the automation controller 12 to the remote controller 14 is to send information requested by remote controller 14, then the automation controller 12 will operate as a slave to the command/input sent by the user via the remote controller 14. Conversely, if the automation controller 12 can request/command certain actions be taken by the remote controller 14, such as report a status, then the controllers will most likely be operating in a peer relationship.

[0050] Embodiments based on FIG. 1 may include one or two way communication between the remote controller 14

and one or more of the peripheral devices 16. The remote to peripheral communication can provide primary, secondary, or alternate communications. For example, the remote controller 14 may be configured merely to serve as a repeater, and thus a peer to peripheral devices 16, for communications between the automation controller 12 and the peripheral devices 16. The remote controller 14 may send a command to the peripheral device 16 that is redundant of command sent by the automation controller 12.

[0051] Also, the remote controller 14 may send the only command to the peripheral device 16. In this instance, the automation controller 12 may be configured to receive this command from the remote controller 14 or the remote controller 14 may send a different command, such as a generic change of state command to the automation controller 12. Upon receipt of a command directed to a peripheral device by the remote controller 14, the automation controller 12 could 1) query the peripheral devices 16 immediately or at a predetermined time to determine its operational state or 2) await a communication from the peripheral devices 16 directly, and/or indirectly via the remote controller 14, indicating their state.

[0052] FIG. 2 shows embodiments of the system 10 including the automation controller 12, at least one remote controller 14, a first group of one or more peripheral devices 16_{a1-an} and a second group of one or more peripheral devices 16_{r1-rm}. In these embodiments, the automation controller 12 communicates directly with the remote controller 14 and the first group of one or more peripheral devices 16_{a1-an}. However, it does not communicate directly, and perhaps not at all, with the second group of one or more peripheral devices 16_{r1-rm}.

[0053] In FIG. 2 embodiments, communication and control of the second group of one or more peripheral devices 16_{r1-rm} is performed via the remote controller 14. In various embodiments, the automation controller 12 will not associate or monitor some or the entire second group of peripheral devices 16_{r1-rm}. In other embodiments, the automation controller 12 will monitor some or the entire second group of peripheral devices 16_{r1-rm}, as the second group provides status information to the remote controller 14. In other embodiments, the automation controller 12 will indirectly control some or the entire second group of peripheral devices 16_{r1-rm}, via commands sent to the remote controller 14. The automation controller 12 may also monitor the second group of peripheral devices 16_{r1-rm}, via the remote controller 14, which can serve as a repeater or to provide additional information along with the monitoring information to the automation controller 12.

[0054] The architecture provided in FIG. 2 provides additional flexibility in tailoring the system 10 for a specific application. For example, the second group of peripheral devices 16_{r1-rm}, may be implemented using a different communication scheme, which is only implemented on the remote controller 14. For example, in various embodiments, the remote controller 14 may be capable of communicating using both IR and RF frequencies, whereas the automation controller 12 may only be implemented using RF frequencies, or different protocols may be implemented on the remote controller 14 and the automation controller 12. In those instances where the communication protocol between the remote controller 14 and the second group of peripheral devices 16_{r1-rm}, differs from the communication protocols implemented on the automation controller 12, then the remote controller 14 may serve to translate the information being

provided from the second group of peripheral devices 16_{r1-rm} to the automation controller 12.

[0055] FIG. 3 shows embodiments of the present invention, in which the remote controller 14 is used to control one or more peripheral devices 16_{1-n}, without an automation controller 12 in the system 10. The remote controller 14 can be used to implement various functions on the peripheral devices 16 depending upon the functionality imparted to the remote controller 14. For example, the processing power, storage capability, user interface, input/output capability, etc. can be tailored to control various numbers of peripheral devices 16 and impart various levels of functionality to the system 10 in the absence of the automation controller 12.

[0056] In various embodiments, the remote controller 14 is configured to communicate directly with the peripheral devices 16 using a suitable protocol, such as Zigbee, Z-Wave, etc., in a first state to send and receive information regarding the function of the peripheral device 16. The remote controller 14 is further configured to operate in a second state in the presence of an associated automation controller 12, where the remote controller 14 communicates directly with the automation controller 12, instead of the peripheral devices 16. If the automation controller 12 becomes unavailable, either because it is removed from the system 10, either physically or via software, or is not working properly, the remote controller 14 will recognize that the automation controller 12 is no longer present, or more generally unassociated with the remote controller 14, and operate in the first state.

[0057] In practice, the system 10 may be in operation without an automation controller 12 using the remote controller 14 to control a plurality of peripheral devices 16. The remote controller 14 recognizes that there is not an associated automation controller 12, so it operates in the first state, directly communicating with and controlling the peripheral devices 16. When the end user of the system 10 introduces an automation controller 12 into system 10, the remote controller 14 recognizes that the automation controller 12 and operates in a second state communicating with the automation controller 12, instead of directly with the peripheral devices 16. As discussed with respect to FIG. 2, the system 10 can be configured so that the remote controller 14 continues to communicate directly with the second group of peripheral devices 16, while communicating via the automation controller 12 with the first group of peripheral devices 16.

[0058] The ability of the remote controller 14 to move between the first and second states can be manually and/or automatically implemented. A hardware switch or software defined key can be used to toggle manually between the first and second states.

[0059] In addition, it may be desirable to keep remote controllers 14 unassociated with automation controller 12 that are detected. For example, in an apartment complex or other space where multiple users are in close proximity, the automation controller 12, as well as other remote controllers 14 and peripheral devices 16 that are within the system 10 operating range may not belong to the end user. In addition, the end user may want to partition a structure to include separate system 10, which may or may not report to a single system for oversight and control.

[0060] The association of an automation controller 12 that is introduced into an existing system 10 being controlled by the remote controller 14, in the absence of an automation controller 12, can be performed in a number of ways. For example, the automation controller 12 can scan its coverage

area and develop a list of peripheral devices **16** and remote controllers **14** that can be associated with the newly introduced automation controller **12**. Also, the remote controller **14** can transfer system information to the automation controller **12**, such as a listing of currently associated peripheral devices **16**, current settings, and activity schedules.

[0061] In these embodiments, the automation controller **12** and the remote controller **14** will continue to operate in a peer relationship, even though the remote controller **14** may not be communicating directly with the peripheral devices **16**. The peer to peer communication would be used by the automation controller **12** to update the remote controller **14** with the latest settings and other information for the peripheral devices **16** that the remote controller **14** would communicate with directly and control, if the automation controller **12** became unassociated with the system **10** during operation.

[0062] In various embodiments, where the remote controller **14** may or may not be configured to control the system **10** in the absence of the automation controller **12**, peer to peer communication between the remote controller **14** and the automation controller **12** may be implemented to enable additional system functionality. For example, persistent storage may be included in the remote controller **14** and the automation controller **12** can be configured to send information concerning the setup and/or operation of the peripheral devices **16** and the automation controller **12** to the remote controller **14** as a data back-up, in the event that the automation controller **12** experiences an outage where data is lost. In addition, the automation controller **12** could be used to change the peripheral devices **16** that will be controlled by the remote controller **14**, if the automation controller **12** becomes unassociated with the system **10**.

[0063] In the some of the above embodiments and others, the remote controller **14** acts as an autonomous device, i.e., without a user inputting information. In these embodiments, it may be desirable to have the remote controller **14** operate in a sleep mode, e.g., with display lights off, etc., and/or include a manual control, such as a switch, to switch the remote controller **14** to a lower power operational state. The sleep/low power mode will extend the battery life. In some embodiments, a holder, or cradle, can be provided for the remote controller **14** that can be used to provide various levels of functionality. For example, the holder may include a power outlet to charge a rechargeable battery. It also may include a communication link for direct communication with the automation controller **12**, other network devices, or an external network. The communication link could allow for the download of configuration files for controlling peripheral devices **16** and secondary devices (described below), software updates, etc.

[0064] FIG. 4 depicts embodiments of the remote controller **14**, in which the remote controller **14** is used to communicate to the peripheral devices **16** via a first signal type, such as Zigbee, and to one or more secondary peripheral devices **18** via a second signal type, such as proprietary Infrared (IR) and/or RF signals. The embodiments enable the remote controller **14** also to serve as a traditional “universal remote” for typical secondary peripheral devices **18**, such as audio and video analog and digital players and recorders (e.g., CD, DVD, VCR, cassette, etc.), televisions/monitors, computers and peripherals, such as MP3 players, blinds, fans, and lights.

[0065] FIG. 5a shows system **10** embodiments that include connectivity to various input, output, and monitoring devices (“input/output devices”) via an external network, such as the

Internet, PSTN, etc. Access to the system **10** can be enabled from a variety of devices, such as computers, mobile and fixed phone lines, personal digital assistants (PDA), etc., as well as from third party service provider networks for system monitoring and control. For example, a computer can communicate directly with the automation controller **12** or via one or more networks including personal, local, metro, and wide area, public and private, intranet and internet networks. Access via the external network provides the end user with the capability to monitor and configure the system **10** remotely. For example, it may be desirable to change the temperature in the house before returning home, or to receive a text message letting you know that some event, such as a door opening, a smoke or CO detector sounding, tagged item/mobile device moving across a threshold, etc.

[0066] As shown in FIG. 5b, the automation controller **12** also can be deployed in client-server architecture, in which one or more computers, acting as clients, provide data entry and access to the controller **12**. The client can also interact with storage devices supporting data storage for the system **10** either directly or via the automation controller **12**. As previously described, the automation controller **12** functionality can be distributed among a number of automation controllers **12** with oversight from a master controller **12**, which may further include client computers for data entry and access. Additional devices also can be employed to provide additional functionality or robustness to the system. For example, storage devices could be employed to off-load data collected by the automation controller **12**. Access to the storage devices could be achieved via the automation controller **12** and/or directly by another computer, which can provide analysis capability off-line from the automation controller **12**.

[0067] In various embodiments in which data is stored in a device external to the automation controller **12**, it may be desirable to enable various software applications on the client computers to enable analysis and planning activities to be performed without burdening the automation controller **12**. For example, client computers can run planning and analysis software tools that enable the user view detailed and consolidated usage information. Planning activities, such as evaluating the impact of varying operational hours or replacing various electrical systems can be investigated using historical data from the system **10**.

[0068] FIGS. 6a and 6b depict various embodiments of the automation controller **12**. In many system **10** embodiments, the automation controller **12** will provide system oversight, coordination, and control of the peripheral devices **16** and the remote controller **14**. Access to the automation controller **12** can be provided internally by the controller and/or external to the controller. In various embodiments, the automation controller **12** may be fully autonomous with data entry and access capabilities provided directly on it. In other embodiments, data entry and access to the automation controller **12** may be completely external.

[0069] As shown in FIG. 6a, the automation controller **12** may include a keypad and/or a visual display to enter and view information. In various embodiments, a touch screen interface may be included to combine the data entry and viewing functionality. In other embodiments the data entry and viewing functionality will be provided outside of the automation controller **12** via a monitor and/or television screen with data entry via the remote controller **14** or support a display and keypad similar to a stand-alone computer.

[0070] The front of the automation controller **12** may also include an IR detector for those embodiments that support receiving IR signals. In those embodiments, the IR transmission capability of the remote controller **14** can be employed to control the automation controller **12**, instead of using the RF transmission link. Also, the automation controller **12** can support the use of a more traditional remote that transmits only using IR signals.

[0071] FIG. 6*b* depicts an exemplary back view of the automation controller **12**. It will generally include a variety of communication ports and transmitters and receivers for the various transmission protocols that are supported. For example, telephone, Ethernet, coax, and/or fiber connections can be provided. USB, RS-232 and 485 and other access ports and monitor connections. Transmitters and receivers for the various wireless transmission protocols are also included. For example, a Zigbee or Z-wave transmitter and receiver can support a first signal type (ST₁) and one or more 802.x transmitters and receivers can support networking via a second signal type (ST₂). In various embodiments, the automation controller **12** will also include an interface to support power line communications with peripheral devices **16** that communicate via power line protocols, such as X10 .

[0072] In addition to the input/output and networking connections and associated hardware and software interfaces, the automation controller **12** will generally include one or more storage devices, as well as one or more processors, depending upon the particular capability being implemented on a particular automation controller **12** embodiment. In general, the automation controller **12** will provide most monitoring, coordination, control, and record keeping functions for the system **10**. The desired system size and capabilities will drive the level of functionality in the embodied in the automation controller **12**.

[0073] The automation controller **12** will typically connect to external power. The automation controller **12** may also include a battery back-up, in case of an external power failure, depending upon the level of reliability desired. While the automation controller **12** could be operated on battery power only, the functionality of the controller **12** generally warrants a continuously available (excepting failures) power source.

[0074] While varying levels of functionality can be embodied in the remote controller **14**, in many embodiments, the full features and functionality of the system **10** are typically accessible and controllable via the automation controller **12**. The automation controller **12** will generally provide menu-driven access to control the peripheral devices **16**. The capability to check, change and schedule a change in status and/or settings for the peripheral devices **16** is generally provided. The automation controller **12** generally stores the system inventory and settings and may also be configured to store that information externally, such as in a computer or mass storage device, or at an off-site network operations center. The back-up of system information can be performed manually or automatically.

[0075] Discovery and association of automation controllers **12**, remote controllers **14** and peripheral devices **16** with the automation controller **12** and/or remote controller **14** can be a manual, automatic, or semi-automatic process. In some embodiments, the automation controller **12** will scan its operational range to discover various system components including other automation controllers **12**, remote controllers **14** and peripheral devices **16** with which it can be associated.

The automation controller **12** can update its potential inventory list each time it detects a new components.

[0076] As part of the discovery process, the automation controller **12** can employ various discovery methods. For example, it can “ping” all the components in its transmission range to send discovery information to the automation controller **12** to ensure a timely and complete inventory is established. The automation controller **12** can also “listen” for signals from components in its reception range, which can be compared to its inventory lists derived from pinging or otherwise. The automation controller **12** can be configured to continue discovery via pinging, listening, or otherwise until a consistent inventory list is produced. Alternatively, it can provide an inventory list of components that can be confirmed via multiple discovery methods, which can be used to define its operational range. It can also identify components that were discovered using one method, but not confirmed via another method. For example, a component that the automation controller **12** discovers by listening, but it does not responds to the ping signal sent by the automation controller **12**. In this example, the component may be within the reception range of the automation controller **12**, but not the transmission range for one or more reasons, such as shielding, partial component failure, etc.

[0077] Association of the peripheral devices **16** and remote controllers **14** with the automation controller **12** can be performed automatically as part of the inventory process. However, it is often times more desirable, even though it is more work, to have the association process be separate from inventory to ensure that only desired associations are made.

[0078] The association procedure for components with the system **10** can involve interaction between the component and the controller as part of the procedure and/or the user can associate the component. The procedure may be limited to adding a component identifier/address to a system database or may be more involved, such as configuring the component to assume particular operational states and/or roles in the network following the association.

[0079] In some instances, it may be desirable to require interaction between the component and the controller to minimize the chances of an improper association. For example, the peripheral devices **16** and remote controllers **14** may have an associate button, switch, key, etc., that must be activated during association. Alternatively, each device may have an association code or device identifier, such as a MAC address, that is entered via the automation controller **12** and/or the remote controller **14** as part of the association process without requiring communication between the controller and the component. The component will then respond to any controller that uses the proper address.

[0080] In various embodiments, a remote controller **14** can be used to initiate and/or perform the association or commissioning process using line of sight communications, such IR, in lieu of or combination with non-line of sight communications, e.g., Zigbee. The use of line of sight communication significantly reduces the probability of a peripheral device or other component being associated with a wrong network in deployment scenarios where systems have overlapping operational ranges, such as in multi-tenant facilities, and does not require physical interaction with the components.

[0081] In an exemplary association process, the remote controller **14** is configured to provide a line of sight signal, i.e., an IR signal, to the peripheral device **16** placing it in an association mode, where it will become associated with the

automation controller 12 and/or with the remote controller 14. In some instances, the peripheral device 16 will remain in an association state until an automation controller 12 and/or remote controller 14 detects its presence and completes the association process. The detection of the peripheral device 16 by the automation controller 12 can be initiated by the remote controller 14 and/or peripheral device 16. For example, the remote controller 14 can be configured to send an association signal to the automation controller 12, in addition to the peripheral device 16. In this example, it may be desirable for the remote controller 14 to send a code/key to the automation controller 12 and peripheral devices 16 that is used in the association process to prevent the inadvertent initiation of the association process with another automation controller 12 within the range. If the association process is not initiated on the automation controller 12 by the remote controller 14, it may be desirable for the remote controller 14 to provide a code/key to the peripheral device 16 for identification in the association process, when it is detected by the automation controller 12.

[0082] In embodiments without a remote controller 14, the automation controller 12 can be configured to associate only with peripheral devices 16 and/or other automation controllers 12 for which a physical address, such as a MAC address, or code/key has been entered into the automation controller 12. The automation controller 12 can also be configured to associate with new components when it is in an association mode as discussed above, as opposed to trying to associate automatically with any component it detects during operation.

[0083] In some embodiments, it may be desirable to associate a peripheral device with an automation controller 12, when the peripheral device is not present within the communication range of the automation controller 12. For example, it may be desirable to associate a peripheral device with multiple automation controllers 12 within one or different systems 10 that have non-overlapping ranges of operation. One such embodiment of non-overlapping ranges is described below with respect to geographically diverse systems that share peripheral devices 16. The association between peripheral devices 16 and automation controllers 12, whether present in the range or not, can be performed by either or both devices 16 and controllers, using identifiers and signaling prompts, as may be appropriate.

[0084] Peripheral devices 16 in the present invention are generally implemented in a function role communicating directly with remote controllers 14 and/or automation controllers 12 depending upon the system configuration and responding to their commands to perform a function, which may include one or more steps, process, and/or actions. Common peripheral devices 16 include electrical wall and device receptacles and jacks, on/off, contact, and dimmer switches, visual (e.g., motion), audio, material (smoke, humidity, CO, radiation, etc.), electromagnetic wave (RF, IR, UV, visible light, etc.), shock, and thermal sensors, thermostats, video equipment (e.g., cameras, monitors), audio equipment (e.g., microphones, speakers), blinds, fans, communication equipment used to provide services, such as plain old telephone service (POTS), voice over Internet Protocol (VoIP), video, audio, and data, etc.

[0085] The peripheral devices 16 can also be used to obtain data from other devices for evaluation, referred to herein as monitoring peripheral devices 16. For example, a sensor or other peripheral device 16 can be configured to monitor signals

output by a piece of equipment or other device and send the signals along with the notification of the signaling event. The signals can be error codes or other performance attributes in various forms, such as visual (flashing lights), audible (beeps), and/or electrical signals that are detected by the devices 16 and forwarded by the system 10 to the relevant parties, if desired. For example, light pattern changes on LEDs (flashing, color, etc.) on computer equipment could be converted to an error code for evaluation or the audible signal from a smoke detector could be evaluated to distinguish low battery alerts from actual smoke detection.

[0086] Data from monitoring peripheral devices 16 can be used as primary data or as data to corroborate data received from other peripheral devices 16 within the system 10. For example, when a smoke detector is embodied as a peripheral device 16 in the system 10, the system 10 can be configured such that the automation controller 12 receives a smoke detected alarm from the smoke detector peripheral device 16 and a corroborating alarm from an audible monitor peripheral device 16 that detected the smoke detector audible alarm.

[0087] The peripheral devices 16 can operate on external and/or battery power depending upon the requirements of a particular device and the accessibility of external power. For example, electrical receptacles may not be required to transmit and receive information frequently, so they could be operated on battery power. However, electrical receptacles are connected in an external power circuit, so those devices will generally be operated using external power, because it is available. Similarly, peripheral devices 16 that are communicating with the automation controller 12 via a powerline communication protocol will be configured generally to use external power as those devices will be connected by the external power lines. If the function of the peripheral devices 16 is something that should remain operational, even when there is an external power outage, then it may be desirable to provide battery power as the primary or secondary power source to the device.

[0088] The peripheral devices 16 can be controlled individually by the controllers or in groups to create "scenes" or to place a structure in a particular operational state, such as set the air and water temperatures, disabling/enabling the door alarms, turning on/off computer equipment and other electrical devices, and unlocking/locking the garage and other doors when a business opens/closes or a person leaves/returns to a residence.

[0089] In some embodiments, such as depicted in FIG. 7, it is desirable to include one or more peripheral devices 16 packaged along with or proximate to the automation controller 12. The close proximity of the peripheral devices 16 to the automation controller 12 allows for a direct wired connection in lieu of, or in addition to, the communication scheme used with other peripheral devices 16. As such, the close proximity peripheral devices 16 can provide a low cost means for controlling devices, which are in close proximity to the automation controller 12. For example, in many cases, the automation controller 12 will be placed in close proximity to audio, video, and computer equipment, as well as lighting, which can be controlled via the low cost proximate peripheral devices 16.

[0090] FIG. 8a shows peripheral device 16 embodiments, in which a plurality of peripheral devices 16 form a control group, which share a common communication interface (transmitters, receivers, etc.) to the controllers 12 and/or 14. The sharing of the communication interface, and in some

instances, some or all of the processing capability, provides for lower cost peripheral devices **16**. In various embodiments, each of the individual peripheral devices **16**_{1-n} in the control group is identified as a separate peripheral device **16**. Whereas, in other embodiments, the entire device **16** is identified as one peripheral device **16** with sub-devices **16**_{1-n}. The identification of the peripheral devices **16** as individual devices or sub-devices is generally left to the skilled artisan. When using sub-device identification, instructions can be given to the device as a whole, which can be left to the device itself to implement. For example, peripheral device **16** can be instructed to turn off, which causes the peripheral device **16** to turn off sub-devices **16**_{1-n}. In the individual device implementation, instructions to turn off are sent to each of the devices **16**_{1-n} for action.

[0091] The FIG. **8a** embodiment, which is shown as a plug strip, is purely for exemplary purposes, as the common interface/processing architecture can be implemented for any application in which the devices are in relatively close proximity or can communicate effectively. For example, track lighting, holiday decorations, etc. can be implemented using this structure.

[0092] As shown in FIG. **8b**, the peripheral devices **16** also can be configured to communicate with other secondary devices **18** or systems. For example, the peripheral device **16** can include communication capability with a computer via USB, Ethernet, serial or parallel port or other connection, which can be wired or wireless. In these embodiments, the peripheral device **16** could send a system message to one or more secondary devices, such as a computer, that power was going to be interrupted and for the computer to perform a graceful shutdown. It could also send a signal that initiates the booting, or starting, up of the computer.

[0093] In various embodiments, the peripheral device **16** is embodied as a plug strip including a power cord for plugging into a power source, such as a standard electrical receptacle, and a plurality of electrical receptacles controlled at least in part by a common processor and using a common transmitter and receiver to communicate with the automation controller **12** via a first signal type, such as Zigbee, Zwave, PLC, 802.x, etc., and a computer via a secondary signal type, USB, etc., to send power up and power down signals to the computer. The common processor could be used to control all functions associated with the plurality of electrical receptacles or additional processors could be used with one or more of the receptacles.

[0094] The peripheral device **16** could further include an energy storage device, i.e., battery, which can be configured to retain sufficient energy to power 1) the peripheral device **16** to signal the computer or other secondary device **18** and 2) the computer or other device for a sufficient period to allow a graceful shutdown, in the event of a primary power failure to the computer or other secondary device **18**. One of ordinary skill will appreciate that many computer and peripheral equipment types include APIs and other signaling protocols that enable the shutdown, restart, and turn-up of the equipment.

[0095] FIG. **9a** shows other embodiments of peripheral devices **16** of the present invention. In these embodiments, one or more peripheral devices **16** are located outside of the operational range (shown as a dashed line) of the automation controller **12** and/or the remote controller **14**, such as devices **16**_{2-n} in FIG. **9a**, referred to as “outside devices”. In these

embodiment, the peripheral device **16**₁, is configured to receive and transmit information to and from the outside devices **16**_{2-n}.

[0096] The relationship between the outside devices and the automation controller **12** can be implemented in various fashions, such as individual devices or sub-devices as discussed with respect to FIG. **8a**. The outside devices may or may not be visible from an automation controller **12** inventory perspective. In various embodiments, the outside devices are visible to the automation controller **12** and are mapped based on their nearest neighbors in a mesh network topology and the outside devices and at least one device within the range (“inside device”) are configured as repeaters, so that instructions from the automation controller **12** can reach the outside devices. In other embodiments, the outside devices are associated with the inside device and may be considered as attributes of the inside device. In this scenario, a controller, **12** or **14**, sends a command to the inside device associated with the outside devices, which is then implemented on the outside devices at the appropriate time by the inside device.

[0097] The means in which the information is provided to and from the outside devices **16** may or may not be the same as the means in which the information was provided from the controllers, **12** or **14**, to the peripheral device **16**, in the range. For example, if the outside devices are electrically connected, then externally powered devices using power line communications between outside devices may be appropriate, while wireless communications may be used for communications between the controller **12** or **14** and the peripheral device **16**. In other applications, outside devices may have diverse functions, such as outside lighting, contact switches on gates and mailboxes, and sensors, it may be more easily implemented using battery powered devices and the same wireless communications protocol as used in within the range of the automation controller **12**. In still other embodiments, wireless communication can be provided by the automation controller **12** and the inside devices **16**, whereas communication and power is provided to the outside devices via Ethernet.

[0098] FIG. **9b** shows another embodiment of the present invention including a peripheral device **16**, that is configured to translate a message from the protocol used by the automation controller **12** to the protocol used by one or more secondary devices **18**, which may be inside, shown as (a) in FIG. **9b**, or outside (b) the coverage range of the automation controller **12**. The translation can be between wireless protocols and/or wireline protocols and implemented in a variety of ways, such as mapping the signal from one protocol to another or by embedded one protocol signal within the other protocol signal, similar to a digital wrapper. For example, the peripheral device **16**, could translate a Zigbee protocol signal to an RS-485 signal to communicate with components in an HVAC system. The RS-485 link could be implemented as a full duplex, 4 wire solution or half-duplex 2 wire solution depending upon conditions, e.g., multiple radio interference conditions, and the amount and frequency of information being communicated through the link. In addition, two translator peripheral devices **16**, could be used to set up a link (c) using a different protocol, while still communicating with other devices using the protocol of the automation controller **12**. In this implementation, this translator devices **16**, may be used to convert from wireless to wired protocols (in this example Zigbee and RS-485) to enable the signal to reach an area more easily accessed using a wired protocol, but where the signal may be sent wirelessly within the area. In this

example, the translator device 16, may be operated in a mode where the Zigbee message is inserted untouched into an RS-485 stream, which is sent to a second translator device 16', where it is received. The 485 stream is analyzed and a Zigbee message is recreated by the second translator device 16' and sent to the destination peripheral device 16.

[0099] In various embodiments, such as those shown in FIG. 4, the remote controller 14 could be used as a translator device to control one or more secondary devices 18. It will be appreciated that if a remote controller 14 is employed as a translator, it will have to be positioned properly to enable it to communicate with the secondary devices 18.

[0100] One of ordinary skill in the art will appreciate further that the range of an automation controller 12 can also be extended via repeater peripheral devices 16, which are used to amplify, typically be receiving and retransmitting signals, without altering the signals. Range extenders are known in the art and commonly available in 802.11 architectures. Of course, the repeater functionality can be embedded in other peripheral devices 16 to eliminate the expense of deploying stand-alone repeater devices.

[0101] FIG. 10a shows embodiments of the system 10 including mobile peripheral devices 16^m, which can be implemented to provide additional functionality to the system 10. Peripheral devices 16 that are fixed in space for a particular application can be referred to as stationary peripheral devices 16 to facilitate description. However, whether a peripheral device 16 is considered stationary or mobile may, in fact, depend upon the specific application and/or system configuration implemented by the user.

[0102] In the present invention, the mobile device 16^m can be used for determining when a subject (person, pet, object, etc) leaves or enters a structure or zone. In these embodiments, a peripheral device 16 can be attached, via bracelet, anklet, collar, or otherwise, to the subject and its transmission can be used to determine when the subject has left the zone, passes through a reception area or proximate to another device, etc. Mobile peripheral devices 16^m can be applied to home, office, or construction areas for theft protection and safety measures as well.

[0103] The system can be configured to geolocate the mobile peripheral devices 16^m operating in an environment with two or more other peripheral devices 16^m. For example, the received signal strength from various receivers can be used to locate the device by determining vectors for triangulation. This application allows a system to determine, not only when a subject has left a zone, but also, with some accuracy, where the transmitting device attached to the subject is located within the zone. This level of geo-location could be either constantly updated, or determined by querying the receivers in the zone. It will be appreciated that the system will determine the general location of the mobile device within the range of the system 10. The precision of the mobile device location will depend upon the desired amount and precision of the information received by the controller 12 from various stationary peripheral devices 16.

[0104] The frequency at which the system 10 tracks the mobile peripheral devices 16 can be configured by the user depending upon a desired implementation of the devices. For example, it may be desirable for the mobile peripheral devices 16 to transmit a signal, when it is prompted manually by remote controller 14 and/or automation controller 12. In these scenarios, the user may want only want to know the location when they are looking for the object, such as a remote con-

troller 14, car keys, or even a pet. The automation controller 12 can be configured to request signals from the mobile peripheral devices 16^m at different intervals depending upon the location of the mobile peripheral devices 16^m within the system range.

[0105] In other instances, the user may want to know as soon as possible, or practical, that a child or disabled adult has left the range of the system 10. In these instances, the frequency and extent of the transmission must be balanced against the battery life of the device. In various embodiments, the mobile peripheral devices 16 will be driven by kinetic energy. An energy storage device, such as a rechargeable battery or capacitors can be provided to store excess kinetic energy. The kinetic energy driven device 16 has the benefit in that the energy to transmit signals is being generated by the motion of the object to which the mobile device 16^m is attached, which is precisely when the energy is needed for transmission. When the object is at rest and no kinetic energy is being generated, the transmission frequency can be much less, because the object is stationary and its location is presumably known.

[0106] In still other embodiments, the mobile device 16^m can lay dormant, i.e., not transmit a signal on its own, unless it is requested by an automation controller 12 or remote controller 14, or is activated/triggered by, or activates, another device in the system. For example, the mobile device 16^m could include an electromagnetic wave (e.g., RF, IR, etc.) detector and/or emitter/tag. In the case of a detector, when the device comes within the range of an emitter, which can be located proximate the exit of buildings, premises, room, or otherwise, the mobile device 16^m would be activated by the emitter signal from the emitter and begin transmitting signals to identify its location. If the mobile device 16^m includes an RF emitter, a RF detector located near a threshold of interest could be used to send a signal to the automation controller 12 that it has detected a mobile device emitter, at which time the automation controller 12 can ping the mobile device 16^m to send a tracking, or location, signal and/or other information that can be used by the controller to track the mobile device 16^m.

[0107] In various embodiments, such as those involving disabled adults and children, the mobile device 16^m will be regularly polled by the automation controller 12 and will be activated by, or activate, another device that is used to monitor the movement of the individual near thresholds of interest, building exits, etc. In this manner, regular updates will be obtained when a person is within a known area and the frequency of updates can be accelerated and notifications made, when a person leaves an area. It will be appreciated that the mobile device 16^m can perform a number of functions, such as measuring temperature, shock, pulse, etc. (i.e., health parameters) for individuals, in addition, to providing a tracking signal.

[0108] In application, when the automation controller 12 determines that an object being tracked with a mobile device 16^m has left some predefined area, such as exiting a building, the automation controller 12 can be configured to communicate the information to the user by the available means, such as email, text message, phone call, audible signal, etc. or merely log the time that object left the predefined range. The automation controller 12 could take the same or a different action when the object wearing the mobile device reenters the predefined range. An example of the automation controller 12 merely logging information could be logging when object

that normally are expected to exit and reenter a range are being tracked, such as vehicles at a dealership or personnel at an office during normal business hours. Extending these same examples, the user may want to be notified when these objects enter and exit the premise during non-normal business hours.

[0109] Peripheral devices **16** can be deployed in data collection modes, if sufficient memory is provided for data storage during the collection interval, instead of transmitting the data as it is collected. The device **16** would then transmit the data collected over the interval to the controller or a display. For example, various sensors can be deployed that log data for periodic review and/or transmission, in lieu of regularly transmitting the data or waiting for a request by a controller.

[0110] A device **16** also may collect data on a fixed interval, but only transmit data when a threshold has been exceeded, such as high/low temperature, shock, gas concentration, humidity, etc., or upon request. Alternatively, the peripheral device **16** can perform some processing of the raw data and transmit only the processed data, while perhaps retaining the raw data for a period of time to allow for retrieval if necessary. For example, the peripheral devices **16** could process the raw data and transmit a moving average of the data and any extreme outliers to the data. In this manner, communication traffic in the system **10** is reduced.

[0111] As shown in FIG. **10b**, devices **16** that are configured to collect data for later access also can be deployed in embodiments, in which two systems **10**, or sub-systems of a larger system, are employed having non-overlapping ranges including geographically diverse configurations. For example, a device **16** that includes one or more sensors for detecting relevant conditions can be provided on the inside and/or outside of a shipping container. The data on the device **16** can be read before shipment by a system **10** at the point of origin and by a counterpart system **10** at the destination to determine the conditions to which the contents of the shipping container were exposed. It may also be possible to read the data en route. If the device **16** is provided within a sealed container, the data collected can be used to verify that a container was not exposed to conditions, temperature, humidity, shock, etc., that could damage the contents and the point in time and duration of the exposure to extreme conditions. The number of devices **16** deployed within a container and the sensors or other instruments included in or associated with the device **16** will generally depend upon the size of the container, (e.g., letter size package, cargo ship container) and the desire for redundant data collection, which may depend upon the value of the contents of the container. In practice, the carrier can be present and confirm the origin and destination data and the shipper/user can implement sufficient security, such that the device **16** is not reset or data compromised during shipment.

[0112] From a tracking perspective, the devices **16** used for shipping can be treated statically or as a mobile device **16^m** by the system **10**. For example, the shipping devices can be detected before or after the device enters a facility to provide data on whether shipments should be rejected, inspected, and/or accepted from a carrier. In other embodiments, each of the geographically diverse systems **10** can be included in a broader overall system from a network management level, such that peripheral devices **16** in each of the local systems can be registered and status maintained in an overall database, such that when the peripheral device **16** re-enters the coverage area of one of the system **10**, it can be detected and the data logged. The overall database could be enabled in various

configurations by one of ordinary skill. For example, the overall database for the plurality of systems, or automation controllers **12**, could be embodied in a multi-level automation controller architecture, in which a master controller provides at least some control over multiple automation controllers **12** or the overall database may be merely a shared database that is accessible by multiple systems.

[0113] In various embodiments, the system **10** includes a limited purpose remote controller (“LPRC”) **22**, which can be a wall mounted, free-standing, or handheld device. The LPRC **22** can be embodied as a configurable on-off or dimmer switch that can be used to control one or more peripheral devices **16** directly and/or via the automation controller **12** or the remote controller **14**. For example, the LPRC **22** can be configured to control one light or one electrical receptacle in a room similar to a traditional light switch. Alternatively, the LPRC **22** could be configured to control a group of lights and/or other peripheral devices **16**. For example, the LPRC **22** could be mounted as a wall switch that could control all of the lights in a basement, turn on and off all of the components in an entertainment system, etc., even if those lights and components are on different wiring circuits.

[0114] FIGS. **11-16** depict various embodiments of the LPRC **22**, which for exemplary purposes, is described in terms of on-off, toggle, or dimmer wall switch. Instead of opening and closing a circuit as in a traditional light switch, the LRPC **22** requests the controller to issue a command to function device to perform a function, such as to turn on or off one or more switches and/or receptacles. In an embodiment, flipping the switch (FIG. **11**) one direction cause one or more lights controlled by function devices to be turned on and flipping the switch in the other direction causes the same lights to turn off. For a button (FIG. **12**), the on-off instructions alternate with each push. In other embodiments, the LPRC could be activated using access control or presence technology, such as RFID or by placing a card in slot or reader.

[0115] In this manner, a wall switch could be used to control any and/or all of the outlets/lights, etc. in a room, rooms, or building, not just those hardwired to a wall switch during construction. The switch can be viewed as a limited purpose remote control for interfacing with the controller and/or peripheral devices **16** via a limited interface.

[0116] Additional functionality can be provided on the LPRC **22**. For example, multiple switches can be packaged similar to traditional circuit control switch, A/B type slide switches can be added to the traditional flip switches to allow the switch to toggle additional functions (FIGS. **3** and **4**). The multi-function switches can employ common or separate processors, transmitters, or receivers depending upon the desired level of functionality (FIGS. **5** & **6**). The switch can be powered via battery or external power. The function of the switch can be programmed, most likely via the controller, to perform the desired function upon actuation of the LPRC.

[0117] In various embodiments, the LPRC **22** can be configured to send a generic automation instruction to an automation controller **12** or a remote controller **14**. Upon receiving the generic instruction, the controller will execute a reconfigurable instruction set controlling a group of one or more peripheral devices **16**. In some embodiments, the same instruction may be sent whenever the LPRC **22** is actuated. In these embodiments, the controller will receive the instruction from the LPRC **22** and execute an instruction sequence for controlling one or more peripheral devices **16** tied to the

receipt of the LPRC 22 instruction. For example, the first signal received from the LPRC 22 might cause the automation controller 12 to turn on one or more lights. The next three signals received from the LPRC 22 in this example, might cause the might cause the automation controller 12 to turn the lights to 66%, 33% and 0% (off) power, respectively.

[0118] In other embodiments, the LPRC 22 will send the actual automation instructions, either directly or via a controller, that instruct the peripheral devices 16 to perform the automation function. In these embodiments, the automation controller 12, and perhaps the remote controller 14, can be used to program the LPRC 22 to send automation instructions for a group of one or more peripheral devices 16. In yet other embodiments, the LPRC 22 will send different generic instructions depending upon its actuation, such as flipping a switch up and down. The controller could be configured to execute different automation commands for each generic instruction received from the LPRC 22.

[0119] As described above, the system 12 can be deployed in a vast number of configurations to achieve the functionality and cost objective of the end user. The automated monitor and control aspects of the system 10 also enable it to provide higher level functions, such as security and energy management.

[0120] In various embodiments, the automation system will perform integrated energy management of part or all of a facility. For example, a user in a may establish a multi-level energy management structure. At a first level, the system administrator establishes administrator settings for day and time of day settings for the HVAC system, hot water heater, etc. Typically, this will involve setting a first temperature range for hours of operation and a second temperature range non-operational hours. Various settings for lighting in the facility may also be established.

[0121] A second level of control can be implemented by monitoring usage at the circuit level for an area, as well as for confirming the integrity of overall and individual usage data. Circuit monitoring also provide the user with data for planning peripheral device roll out, as well as for providing more granular operational hour control.

[0122] A third level of control may be implemented at the work space and common area level. For example, the temperature of a work space may be controlled depending upon whether or not a person is present at the facility or whether a meeting is scheduled or people are present in a work space, such as a conference room. Also, the hallways and other common areas may be controlled to a different temperature and/or lighting intensity. Circuit level control also can be used in some just in time power deployments, when the first and last person enters a work area and for spaces and/or jobs that are not suitable for control at the individual work space level.

[0123] The concept of controlling the temperature and lighting depending upon the presence of a person at the home or work place can be extended more generally to “just in time” energy management. In various embodiments, the automation controller 12 provides access control and/or monitoring or interacts with an access control/monitor system and part of a person’s work space or a residence is not supplied electricity unless the person is present. Upon detection of a person entering a facility, the automation controller 12 would turn on the supply of power to a person’s work space and adjust the temperature of the work space accordingly. In various embodiments, the automation controller 12 could begin powering up computer equipment and peripherals, so

the equipment is ready to use when a person reaches their work space. When a person leaves a work space, the automation can direct the return of the work space to non-operational or out-of-the-work-space operational set points. An analogous procedure can be implemented for a residence.

[0124] At another level, the automation controller 12 can coordinate the different energy management activities within a facility and/or work space. For example, a work space environment will be defined at least in part by the temperature and lighting intensity. The automation controller 12 can be configured to balance the solar impact, i.e., light and heat provided by sunlight or natural light, within an area with the light and heating/cooling provided by the building systems to minimize the energy cost.

[0125] In this case, the automation controller 12 could control various peripheral devices 16, including lights, HVAC vents, window blinds, etc. in a coordinated manner to reduce energy consumption. For example, the temperature and light intensity within a work space/area is defined in the controller 12. During the course of the day, the blinds would be open to varying degrees. When it is night, the controller 12 can close all of the blinds for privacy and to increase its effectiveness as a thermal barrier. During the day time, but not during operational hours, the controller 12 can leave the blinds closed, if desired, or open the blinds an appropriate amount to balance the solar impact with the temperature and lighting demands of the space. During non-operational daylight hours or when the work space is unoccupied, the control of natural light does not have to consider glare from natural light when determining the amount of natural light to allow in the space or the direct impingement of sun light on a person in the space. Whereas, when a person is present in the work space, solar impact issues typically have to be considered.

[0126] The specific types and number of peripheral devices 16 used to coordinate the light and temperature control provided by the facility/building system with the solar impact, sun light and thermal energy, can be determined by the skill artisan. For example, one or more light controllers and temperature controllers for the building systems can be deployed in the area along with blind controllers, external and internal temperature and light sensors, motion detectors, etc. The automation controller 12 can be configured to maintain administrator settings for light intensity and temperature in the area by operating the blind controller to allow sun light and thermal energy to enter the area and adjusting the light and temperature controllers to control the amount of lighting and energy provided by the building systems accordingly. The operation of the devices 16 can be configured in various ways, but a default configuration may be to minimize lighting and HVAC costs for the area, while operating in conformance with the area settings.

[0127] The automation controller 12 also could interact with an area controller that could be coordinating the peripheral devices 16 within an area. For example, the area controller could include or be associated with various sensors, such as temperature, light intensity, and motion, in the area, which provide local information used to control the area environment. The area controller could be used merely to provide a single point of contact for a given area to the automation controller 12 or could be configured to control various actions of the peripheral devices 16 in the area. In various embodiments, the area controller can be used to turn power on and off to an area, which can be triggered manually, flipping a switch,

inserting a card, etc. or upon detection of a person, via RFID or otherwise, or condition, similar to an LPRC as discussed above.

[0128] For energy management, the system **10** generally will be implemented by an administrator that configures the automation controller **12** and add peripheral devices **16** to the system. The administrator will generally establish various settings (“administrator settings”) for the performance of functions relating to energy consumption for the peripheral devices **16** based on the day, time of day, the presence of at least one person within an area in the facility, environmental conditions outside the facility and solar impact within the area.

[0129] The administrator settings can include set points, limits, and ranges, and provide for user input consistent with the administrator settings. In various embodiments, the automation controller **12** can be configured to determine the financial impact of allowing user variations to the administrator settings. The information can be used to modify the administrator settings and suggest alternative user settings.

[0130] The system can be configured to adapt to the behavior of personnel with the facility, which can modify administrator settings or merely provide the data to the administrator for information or action. For example, the system can monitor the presence of personnel in the area and adapt the set point times for transitioning from a person present in the area settings to not present in the area settings.

[0131] The transition set point times can be different for different energy consuming devices in the area. For example, various equipment lights and displays can be dimmed or turned off almost immediately when a person leaves the area, while it is often not desirable to turn off or hibernate a computer immediately when a person leaves the area. Voice over Internet Protocol (VoIP) phones, which do not locally host messaging or other services, can be turned off when a person is not present in the area and/or facility. Also, displays can be turned off when not in use and turned on when the server forwards a call to the phone or the phone is prompted by the user.

[0132] Other devices that employ Power over Ethernet (“PoE”) can also be turned on and off via the system **10**, as well as part or all of the local area network (“LAN”), when there are no users on the LAN. In various embodiments, the devices **16** can be configured to transmit a wake up, or start up, signal back to the LAN equipment, i.e., servers, switches, etc., to power up a portion of the LAN for use. In various embodiments, the devices **16** can be implemented to communicate with secondary devices, such as those embodied in and described relative to FIG. **8a** & **b**, and with the LAN server. In these embodiments, the device **16** can communicate start up and/or shutdown signals to both the LAN equipment and the computer equipment. An example of these embodiments is a plug strip/surge protector that is connected via Ethernet cables to a computer and the LAN. In the case of a start-up, upon notification that a user of the computer is present in the facility or otherwise, the device **16** will send start-up signals to both the computer and the LAN. The device **16** will also enable the supply of power to the power receptacles in the plug strip allow the computer and other electrical devices to power up. Similarly, when there is to be a shut down, because the user is no longer present, there is a power interruption, or otherwise, the device **16** would send shut down signals to the computer and the LAN.

[0133] Various access control technologies, such as RFID, IR, etc. can be used to track the movement of personnel and assets within a facility, in addition to access to the facility. Access tracking within the facility can be used to trigger the transition from a person being present in an area to not present, and vice versa. For example, the access control system can detect when a person moves between the different parts of a facility, such as laboratory, manufacturing, administrative, etc., and transition the person’s work area to present or not present state.

[0134] The extent of deployment of the system **10** will determine the level of detail of the information provided to the user and available for control of the information. In various embodiments, the system **10** will include at least one peripheral device **16**, such as a current, power, and/or voltage monitor, for monitoring the overall energy consumed within a managed area as a function of time. The various peripheral devices **16** deployed within the managed area will provide more specific electrical usage data. In a typical scenario where the peripheral devices **16** are not monitoring all electrical consumption points, the system **10** can be configured to provide overall, circuit, monitored, and unmonitored usage statistics that will allow a user to determine the cost effectiveness of additional monitoring in the managed area.

[0135] The system **10** can be configured in many different ways depending upon the extent of the deployment within a facility and the objectives. The system **10** can provide detailed reporting and analysis of energy usage and the operation of the various monitored equipment. The operational information can be used in combination with electricity rates from the utility to align the usage of electricity with the cost of electricity. For example, the controller **12** can implement rules to allow some activities only at night during hours of lower cost electricity. Also, the user can analyze the impact of replacing equipment with new equipment, installing solar or other power generation capabilities on site, or employing other sources of energy during various times of the day.

[0136] The system **10** can also be configured to participate in demand-response programs in cooperation with utilities and/or energy brokers, in which during times of peak demand, the operational set points of one or more energy consuming devices, typically the air conditioning unit, is varied to reduce power consumption during period of high demand. Using the system **10** of the present invention, the demand-response program can be implemented at a more specific level to provide additional savings and improved comfort. For example, instead of the utility or energy broker cycling the air conditioning units for a facility, the automation controller **12** could increase the temperature set point for various parts of the building that are less sensitive to temperature change or have a local, non-utility power capability, such as batteries, solar, etc., which could pick up the load. The controller **12** can also delay certain processes from occurring until the demand-response condition has passed.

[0137] In various embodiments, the actual energy consuming devices that are operated to consume less energy can be tailored to the amount of energy reduction being requested by demand-response client, i.e., utility or energy broker. For example, the automation controller **12** may determine that the requested energy consumption reduction requested by the client could be achieved by raising the temperature in various parts of the facility, such as rooms not currently occupied, by a few degrees and dimming the lighting in the hallways, rather than cycling the air conditioning for the entire facility.

[0138] In application, the administrator of the system can assigned various peripheral devices **16** associated with energy consuming devices to be turned off or operated at lower power settings as a function of the requested power reduction. The administrator can also establish a hierarchy of devices and the associated energy reduction for each device, such that the system **10** starts at the top of the list and implements the reduced energy settings until the cumulative reduction of all the devices achieves the requested reduction.

[0139] In various applications, the administrator can establish target energy reduction amounts based on the demand-response system. For example, a demand-response system can be established by the client that provides for varying levels of incentives, e.g., rebates, credits, points, etc., corresponding to the extent of the energy reduction made by the user. These types of demand-response system enable the administrator of the system **10** to reduce energy consumption according to the established hierarchy in order to achieve a target incentive amount established by the client as a function of the energy reduction.

[0140] These and other variations and modifications of the present invention are possible and contemplated, and it is intended that the foregoing specification and the following claims cover such modifications and variations.

What is claimed is:

- 1.** An automation system comprising:
 - at least one peripheral device that performs a function;
 - a remote controller configured to send and receive information regarding the function to and from the peripheral device in a first state; and,
 - an automation controller configured to
 - send and receive information regarding the function to and from the peripheral device, and receive information from the remote controller,
 wherein, the remote controller is configured to
 - send information to the automation controller but not the peripheral device in a second state and
 - operate in the first state when the remote controller is unassociated with the automation controller and in the second state when the remote controller is associated with the automation controller.
- 2.** The automation system of claim **1**, wherein the peripheral device is one of a plurality of peripheral devices selected from the group consisting of on/off switches, dimmer switches, electrical receptacles, light sockets, sensors, audio equipment, video equipment, environmental, access, and electrical controls, and communication equipment.
- 3.** The automation system of claim **1**, wherein the peripheral device is one of a first group of peripheral devices associated with the remote controller and the system includes a second group of peripheral devices unassociated with the remote controller, which are not controlled by remote controller in the first state, but are associated with the automation controller and controllable via information from the remote controller in the second state.
- 4.** The automation system of claim **1**, wherein the remote controller is unassociated with the automation controller upon the occurrence of at least one condition selected from the group consisting of the remote controller being manually unassociated with the automation controller and the automation controller not being detected by the remote controller.
- 5.** The automation system of claim **1**, wherein at least one of the automation controller and remote controller is configured to send and receive information regarding the function

with at least one input/output device including at least one of a computer directly communicating with the automation controller, a computer communicating via internal and external networks including personal, local, metro, and wide area, public and private, intranet and internet networks, a monitor, a touch screen display, a keyboard, a mouse and other input and/or output devices.

6. The automation system of claim **1**, wherein the remote controller is configured to communicate with secondary devices using a second signal type and the peripheral devices and automation controller via a first signal type.

7. The automation system of claim **6**, wherein the second signal type includes signals sent in the infrared spectrum and first signal type includes signals sent in the radio frequency spectrum.

8. The automation system of claim **1**, wherein:

the at least one peripheral device includes a plurality of peripheral devices in a control group having a common transmitter and receiver; and,

at least one of the remote controller and the automation controller is configured to send and receive information regarding the function of the plurality of peripheral devices in the control group via the common transmitter and receiver.

9. The automation system of claim **8**, wherein the at least one of the automation controller and remote controller sends and receives information via a wireless transmission link and the control group is configured to send and receive information from the common transmitter and receiver to the peripheral devices via at least one wired transmission link.

10. The automation system of claim **8**, wherein at least two of the peripheral devices are controlled by a common processor communicating with the common transmitter and receiver.

11. The automation system of claim **1**, wherein:

the at least one peripheral device includes at least one mobile peripheral device configured to emit a tracking signal and a plurality of stationary peripheral devices configured to receive the tracking signal and transmit information concerning the signal; and,

at least one of the remote controller and the automation controller is configured to receive information from the plurality of stationary peripheral devices and determine at least a general location of the mobile peripheral device based on the information.

12. The automation system of claim **11**, wherein the mobile peripheral device emits a tracking signal at a rate, which is a function of at least one of its movement, its location within the range of the system, and settings from the remote and automation controller.

13. The automation system of claim **11**, wherein the mobile peripheral device emits a tracking signal that is not recognized by the remote controller or the automation controller, but by a stationary peripheral device, which transmits the information to at least one of the remote controller and the automation controller.

14. The automation system of claim **1**, further comprising a limited purpose remote controller configured to send an automation instruction upon actuation to a reconfigurable group including at least one of the peripheral devices.

15. The automation system of claim **1**, wherein the remote controller is configured to provide a line of sight signal to the peripheral device to initiate an association process between

the peripheral device and at least one of the remote controller and the automation controller.

16. The automation system of claim **1**, wherein the at least one peripheral device is configured to translate signals sent by at least one of the automation controller and remote controller into signals for controlling secondary devices and communicating the translated signals to the secondary devices.

17. The automation system of claim **16**, wherein the at least one peripheral device is configured to translate signals sent by at least one of the automation controller and remote controller in one of Zigbee, Zwave, and PLC format into signals in one of RS-485 signal format for controlling at least one of HVAC units and hot water heaters, and application programming interface format for providing on/off control of a computer.

18. An automation system comprising: at least first and second automation controllers configured to communicate and control peripheral devices in non-overlapping system ranges; and, at least one peripheral device that is associated with both the first and second automation controllers and including at least one sensor configured to monitor at least one of the following conditions, temperature, shock, moisture, air composition including humidity, and contaminant levels, when the peripheral device is not within the range of

the automation controllers, and a data storage devices to store at least some of the data from the sensor for retrieval by at least one of the automation controllers.

19. A method of automating functions comprising: configuring a remote controller to send and receive information regarding a function to and from at least one peripheral device in a first state and to send information regarding the function to an automation controller, but not the peripheral device, in a second state; and, operating the remote controller in the first state when the remote controller is unassociated with the automation controller and in the second state when the remote controller is associated with the automation controller.

20. The method of claim **18**, wherein configuring includes configuring a peripheral device to perform at least one of translating signals sent by at least one of the automation controller and remote controller into signals for controlling at least one secondary device and communicating the translated signals to the secondary device, and, emitting a tracking signal at a rate, which is a function of at least one of its movement, its location within a signal range, and settings from the remote and automation controller.

* * * * *