



US 20080168789A1

(19) **United States**

(12) **Patent Application Publication**
Jones et al.

(10) **Pub. No.: US 2008/0168789 A1**
(43) **Pub. Date: Jul. 17, 2008**

(54) **METHOD AND APPARATUS FOR
CONDENSING WATER FROM AMBIENT AIR**

(86) PCT No.: PCT/AU2004/001130

(75) Inventors: **Darryl John Jones**, New South
Wales (AU); **Graeme Allan
Collins**, New South Wales (AU);
Tauaiti Wally Royal, New South
Wales (AU)

§ 371 (c)(1),
(2), (4) Date: Feb. 13, 2006

(30) **Foreign Application Priority Data**

Aug. 20, 2003 (AU) 2003904488

Publication Classification

(51) **Int. Cl.**
F25D 21/14 (2006.01)

(52) **U.S. Cl.** 62/291

(57) **ABSTRACT**

Correspondence Address:
EDWARDS ANGELL PALMER & DODGE LLP
P.O. BOX 55874
BOSTON, MA 02205

(73) Assignee: **Vital Earth Technologies Pty
Limited**, Medowie, New South
Wales (AU)

There is provided methods and apparatus (2) for collecting water from ambient air. The apparatus has at least one condensation surface which is cooled to, or below, the dew point of the ambient air. The cooling of the condensation surface is effected by utilising a gas to reduce the partial pressure of refrigerant vapour to effect evaporation of liquid refrigerant. Water in ambient air that contacts the cooled condensation surface condenses and is collected. There is also provided apparatus for effecting cooling and/or heating.

(21) Appl. No.: 10/568,405

(22) PCT Filed: Aug. 20, 2004

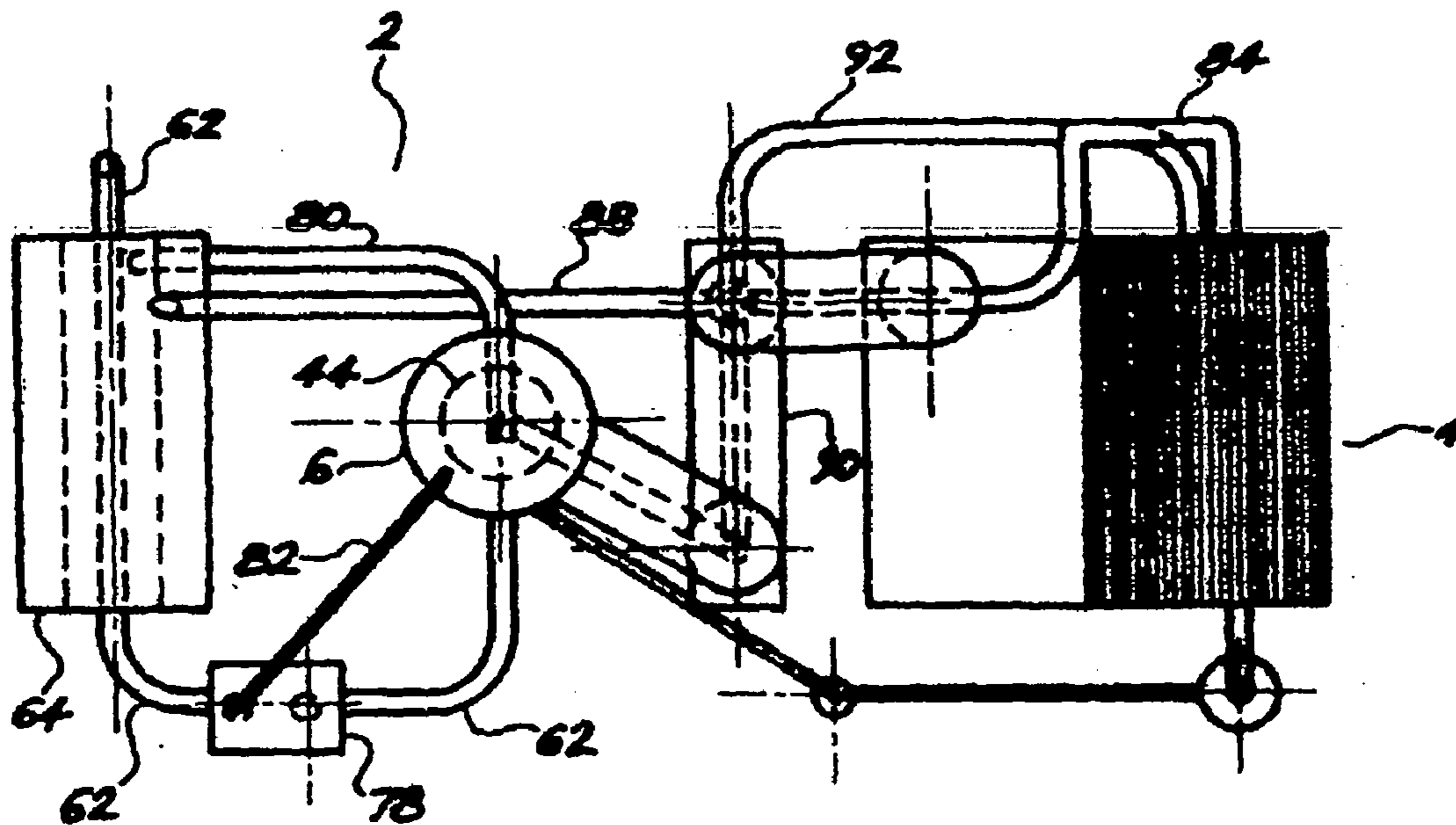

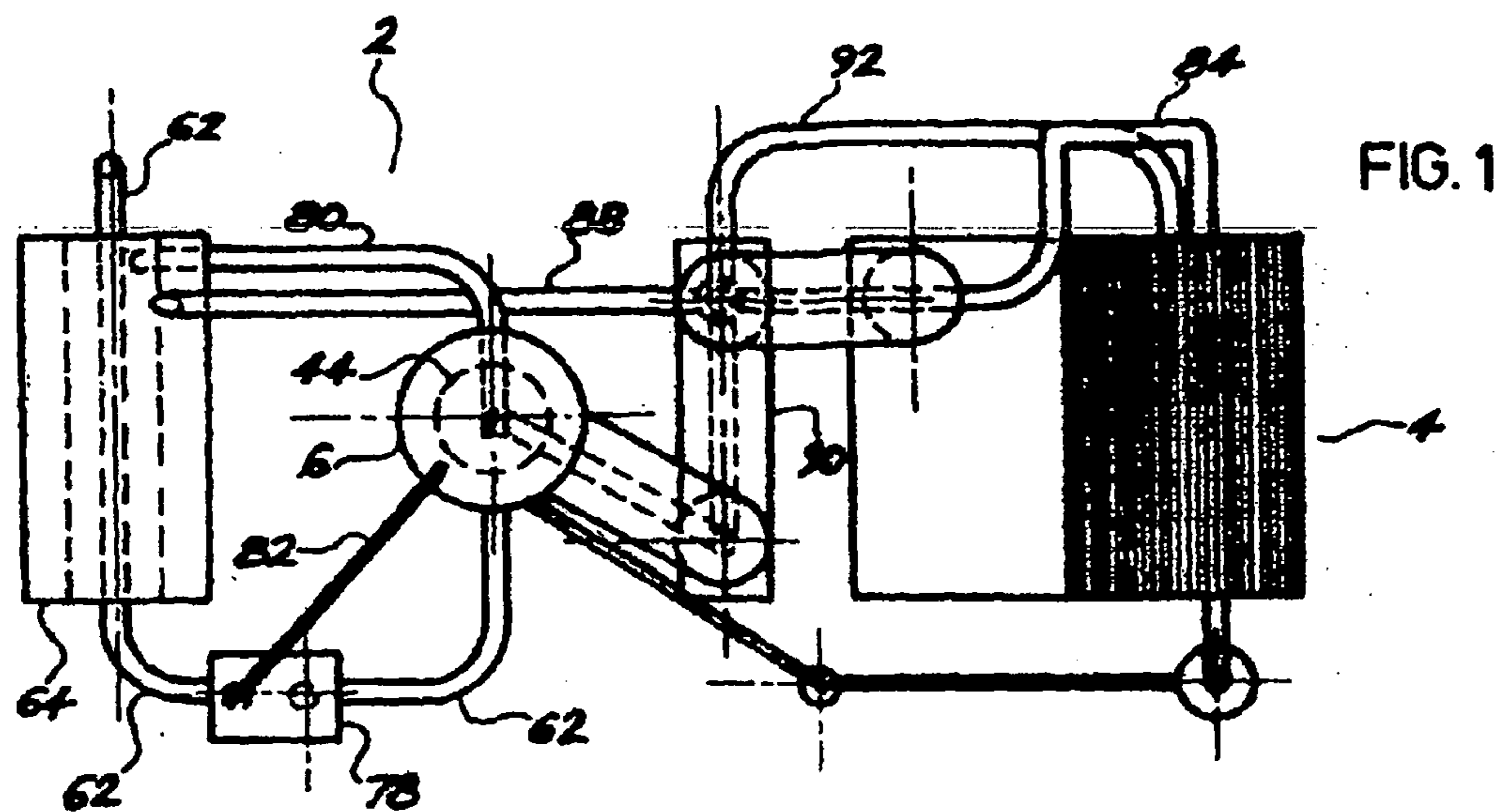

FIG. 1

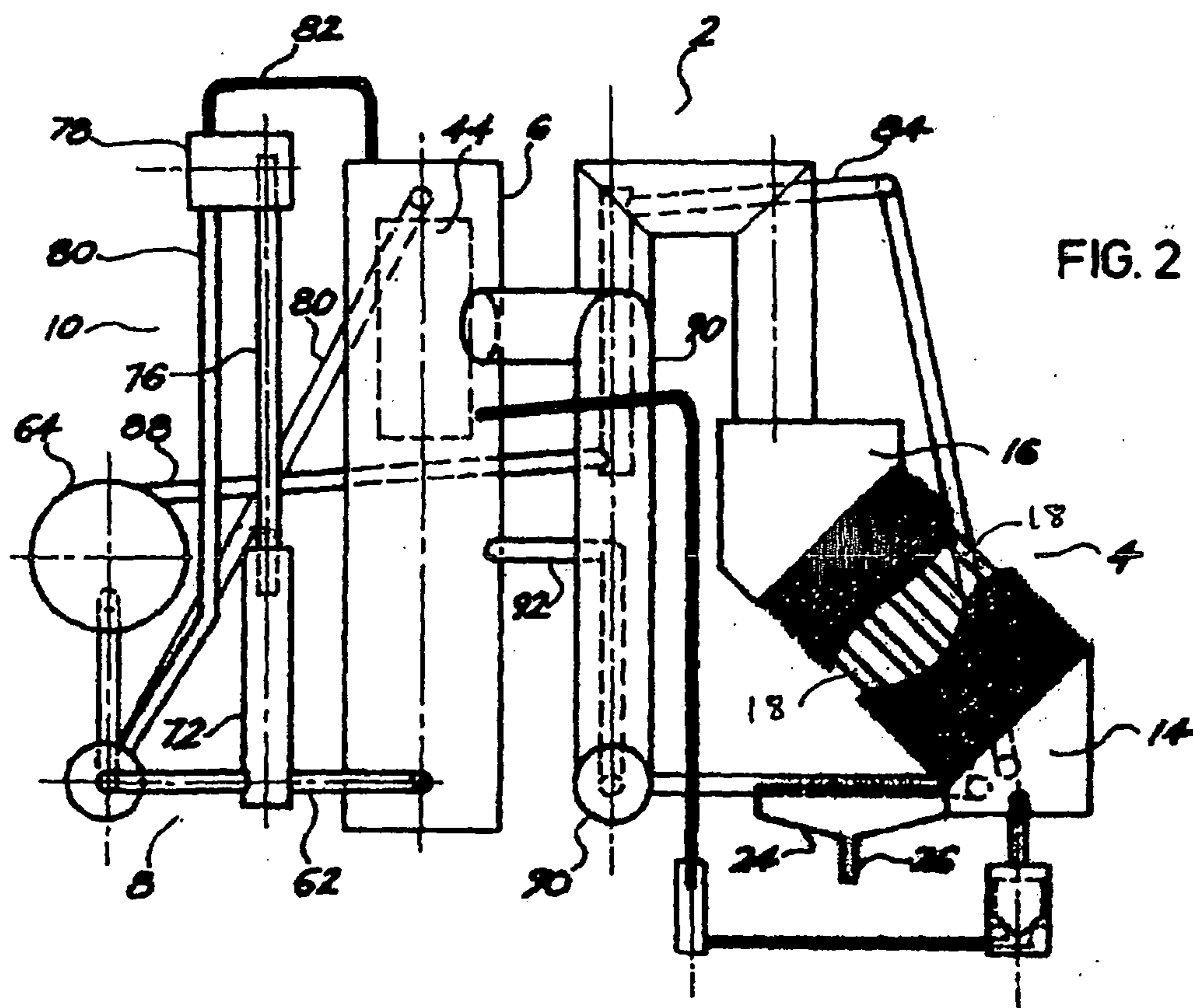
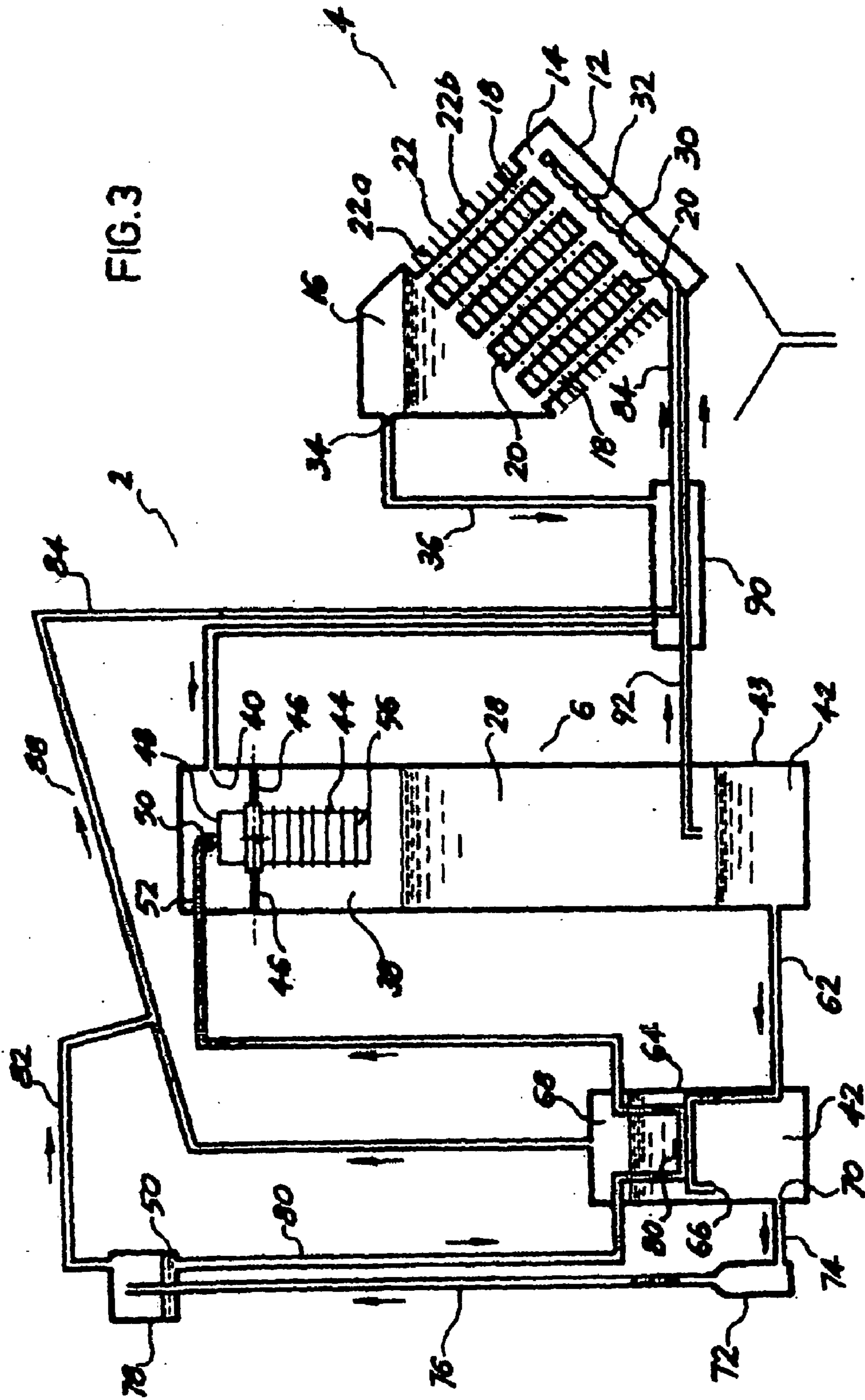

FIG. 2



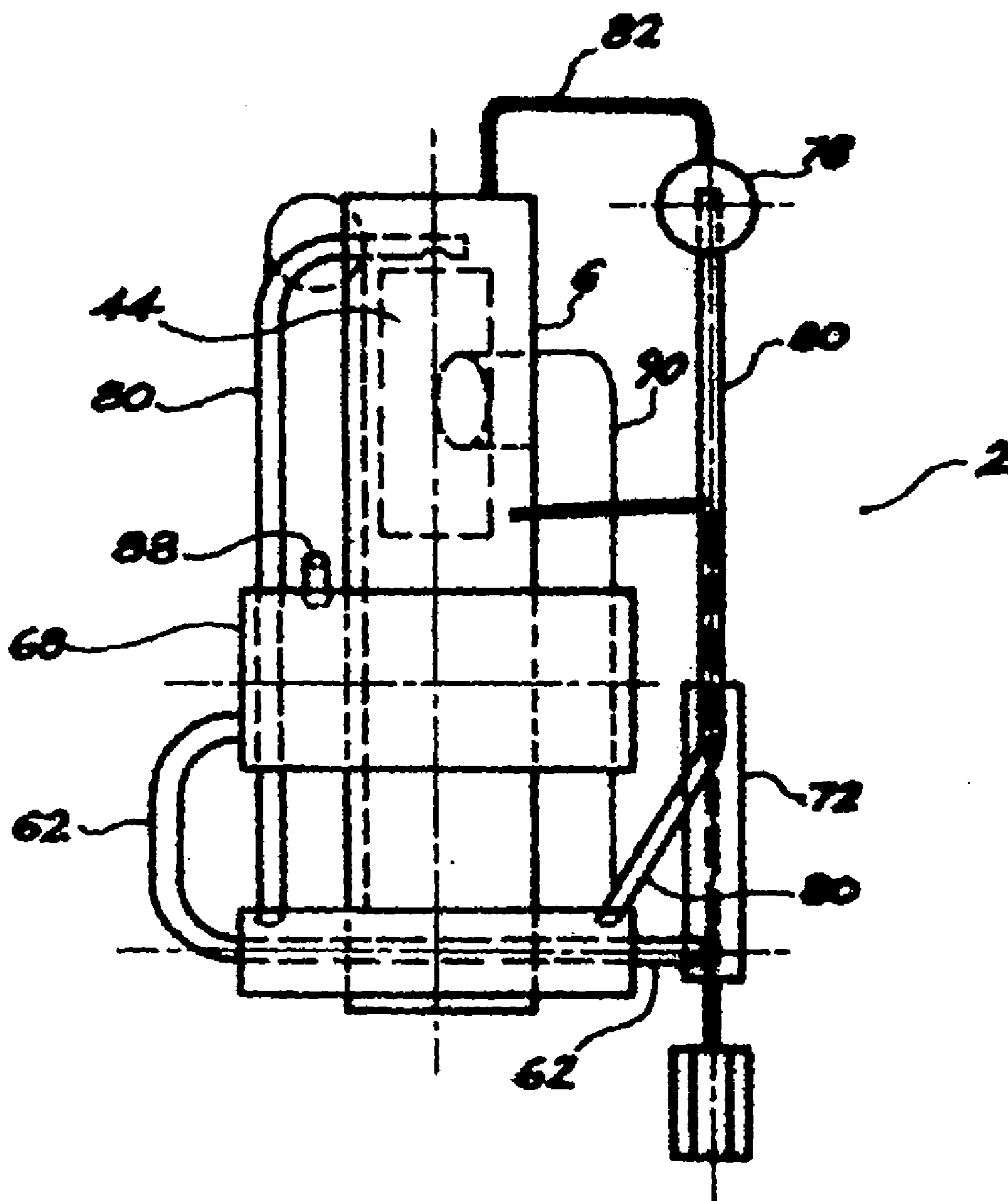
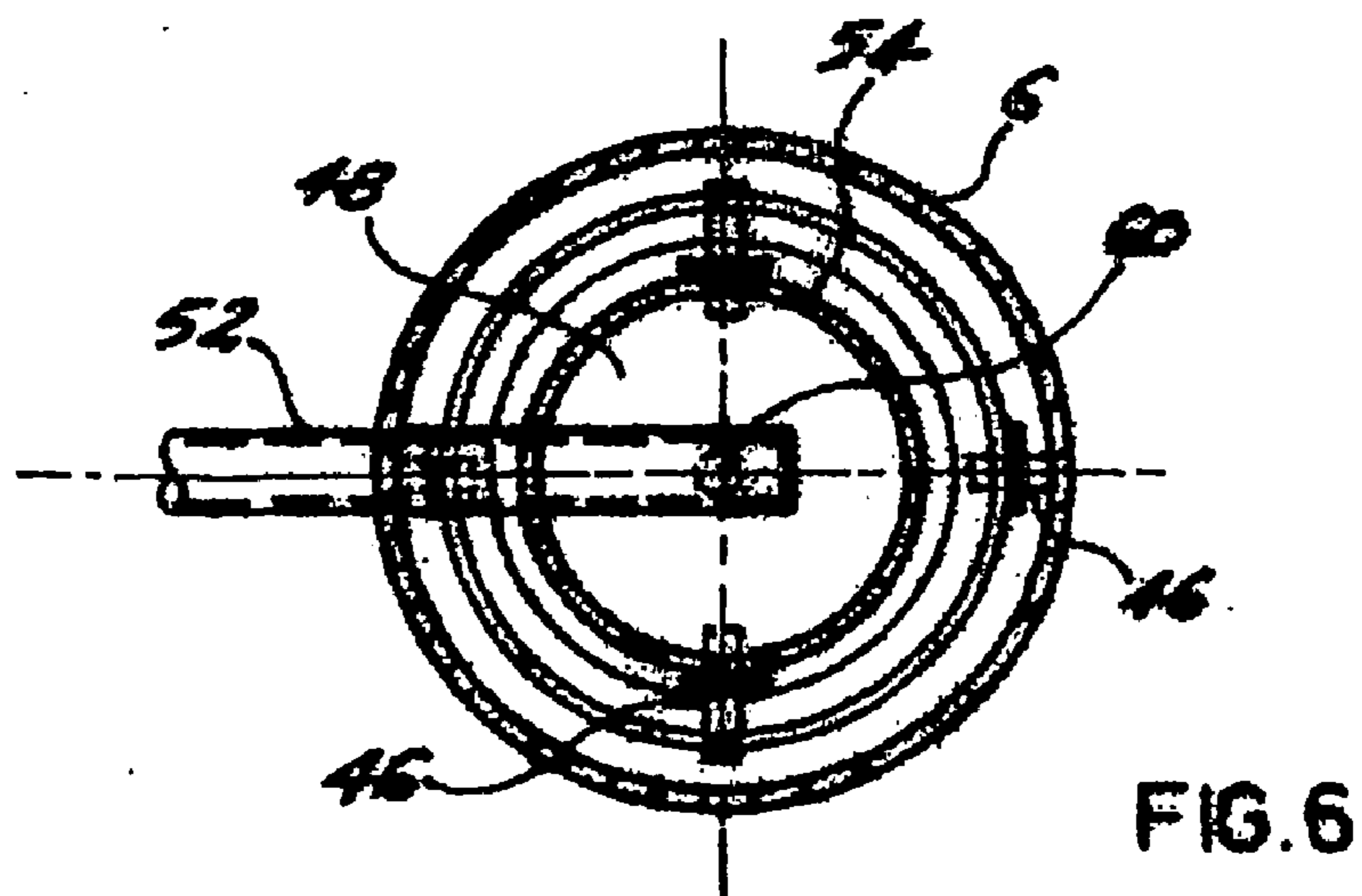
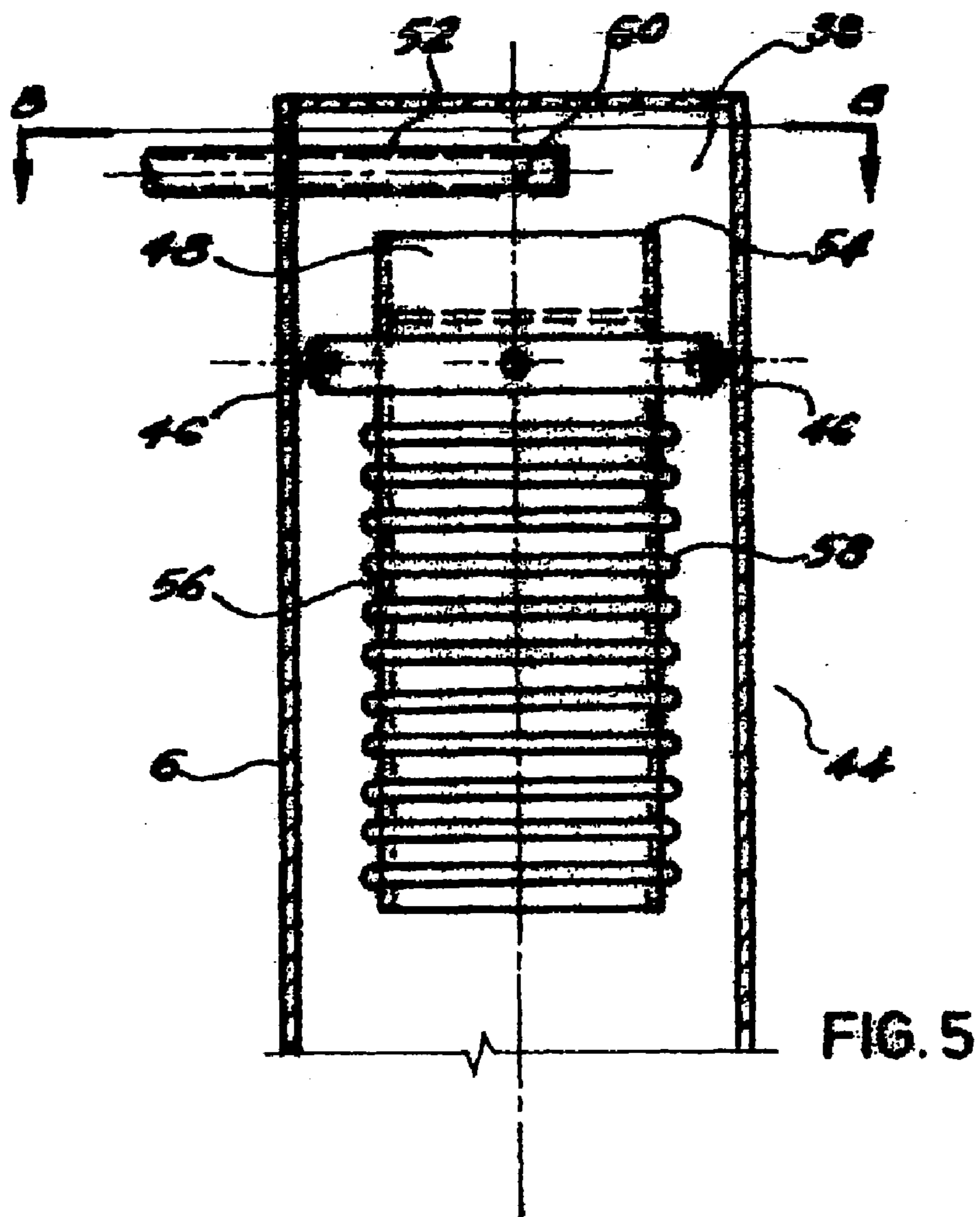
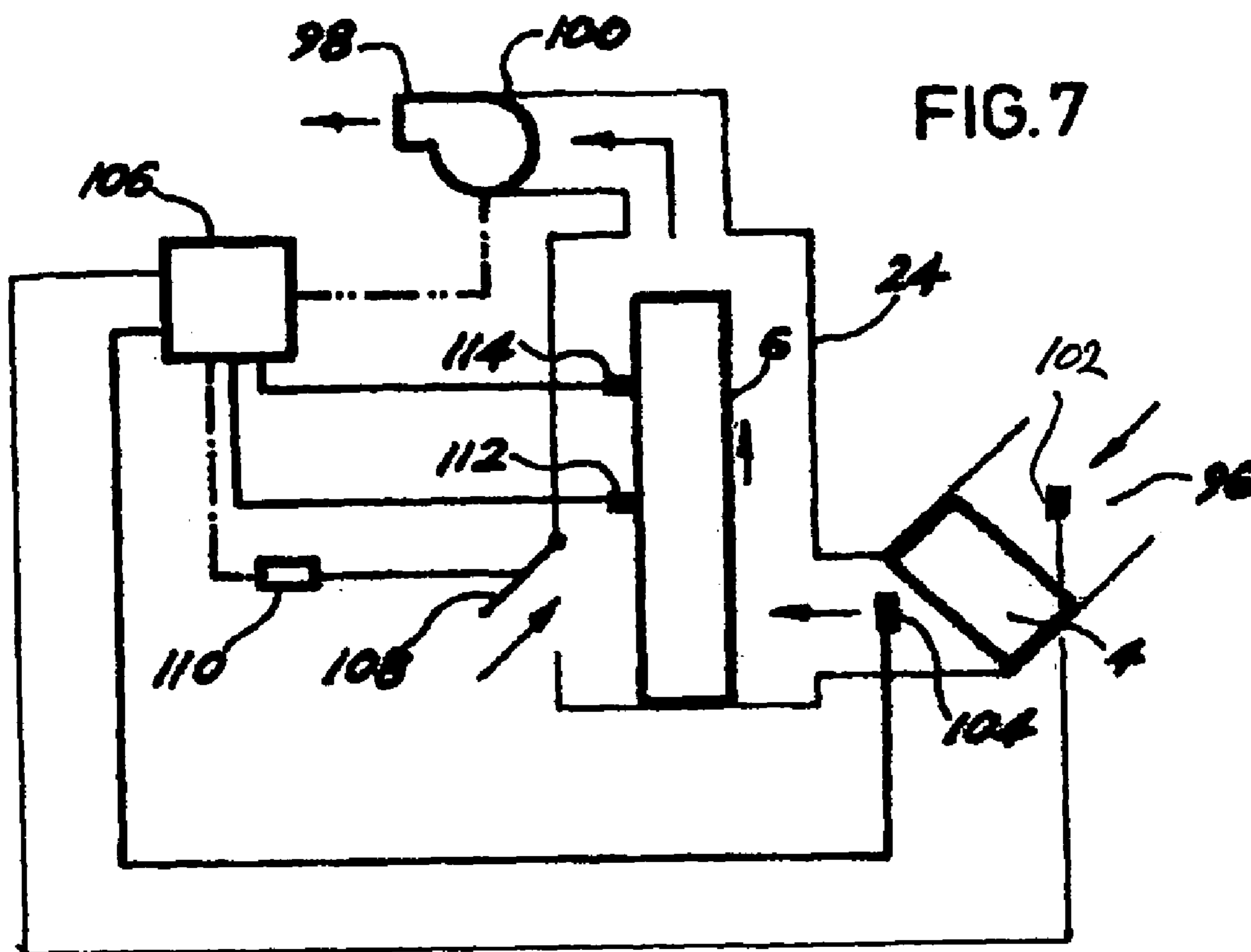
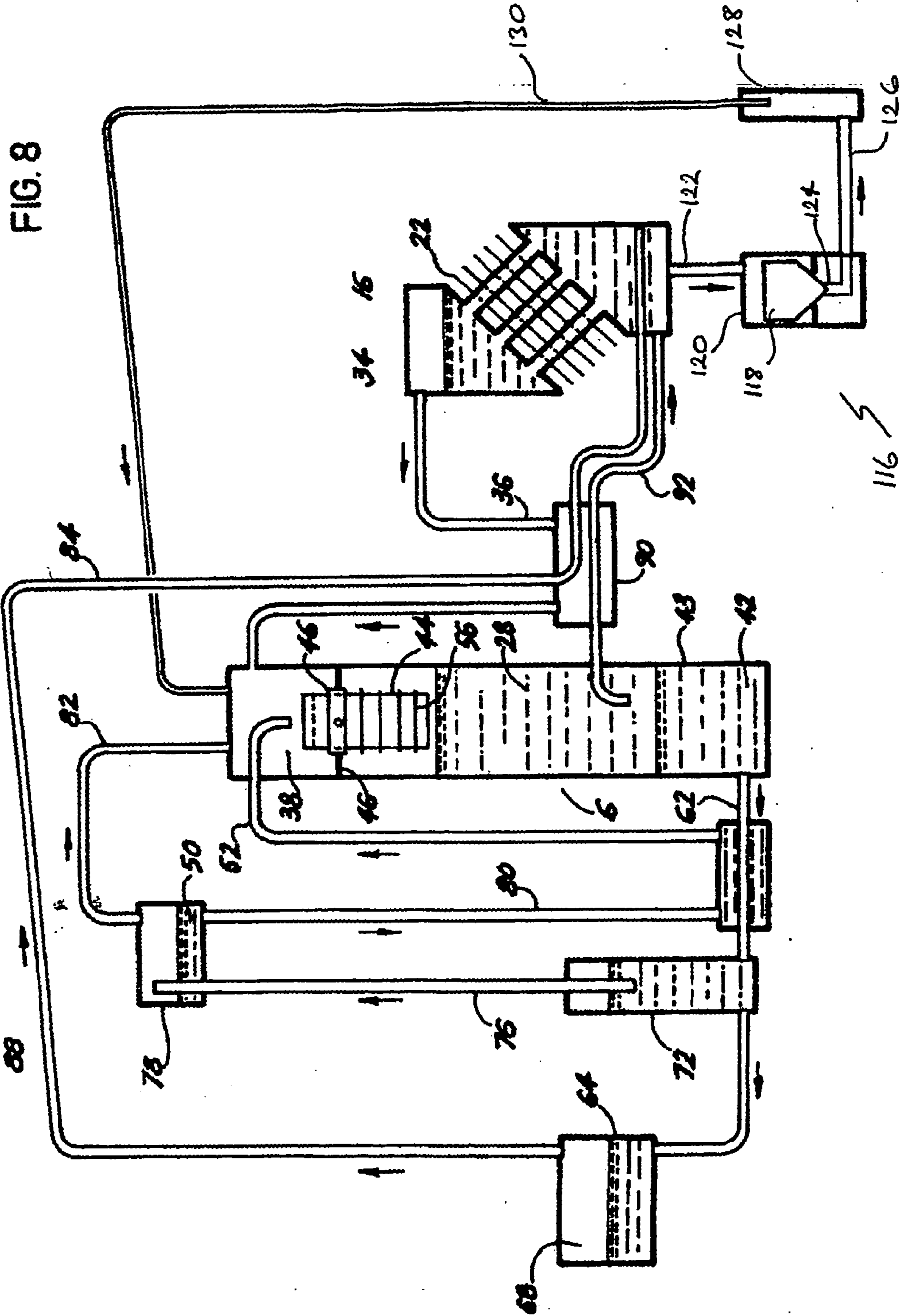

FIG. 4







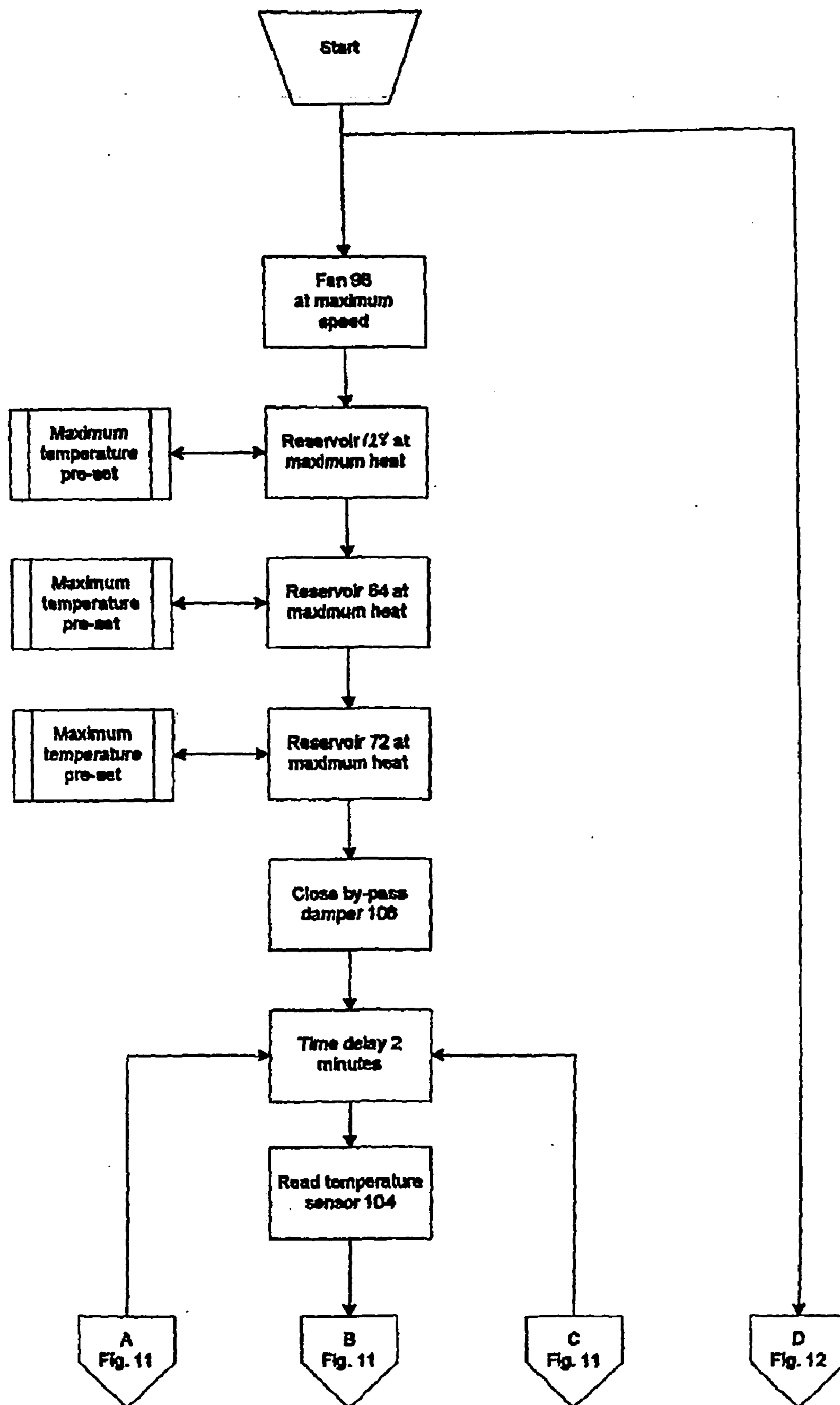

FIG. 9

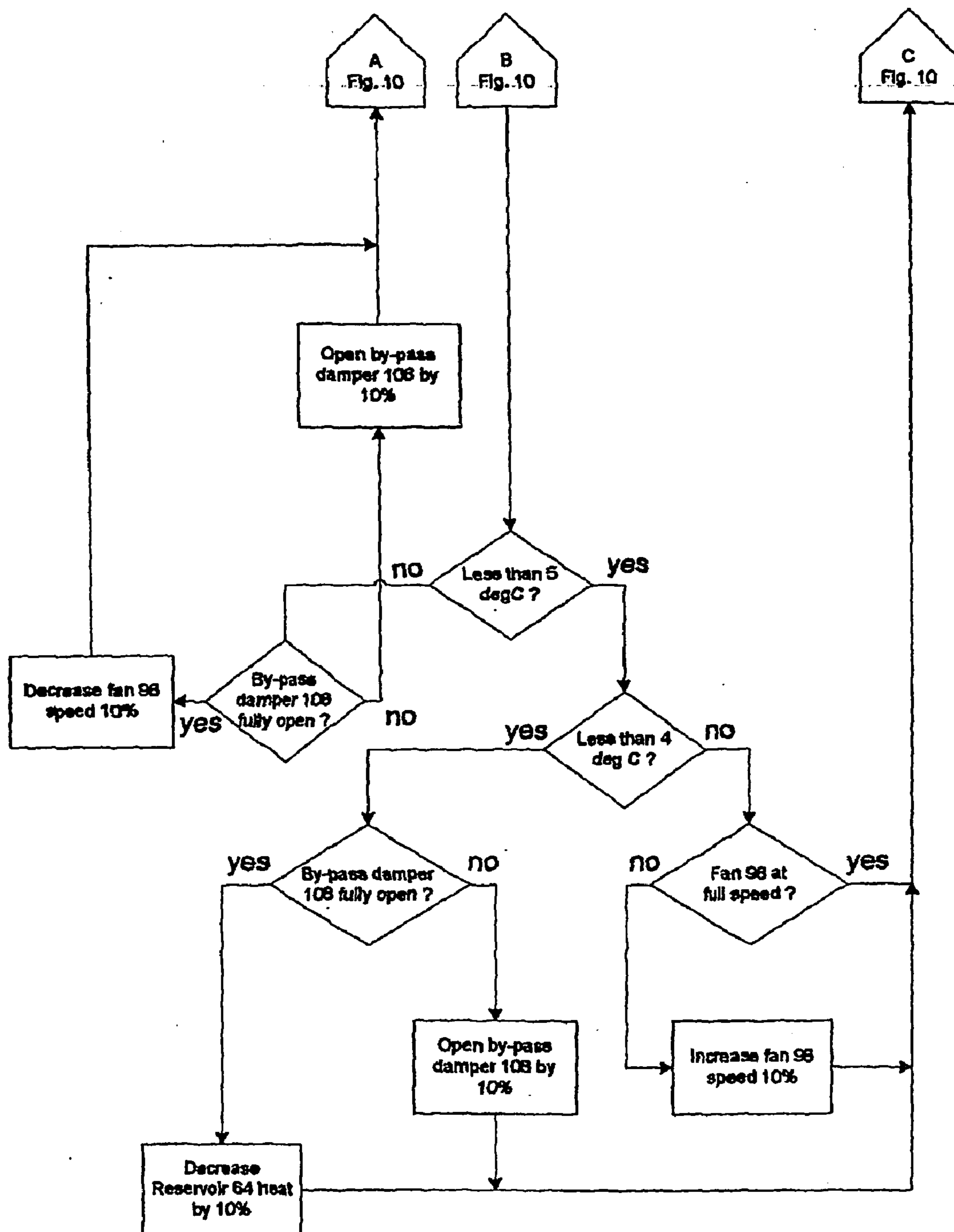

FIG. 10

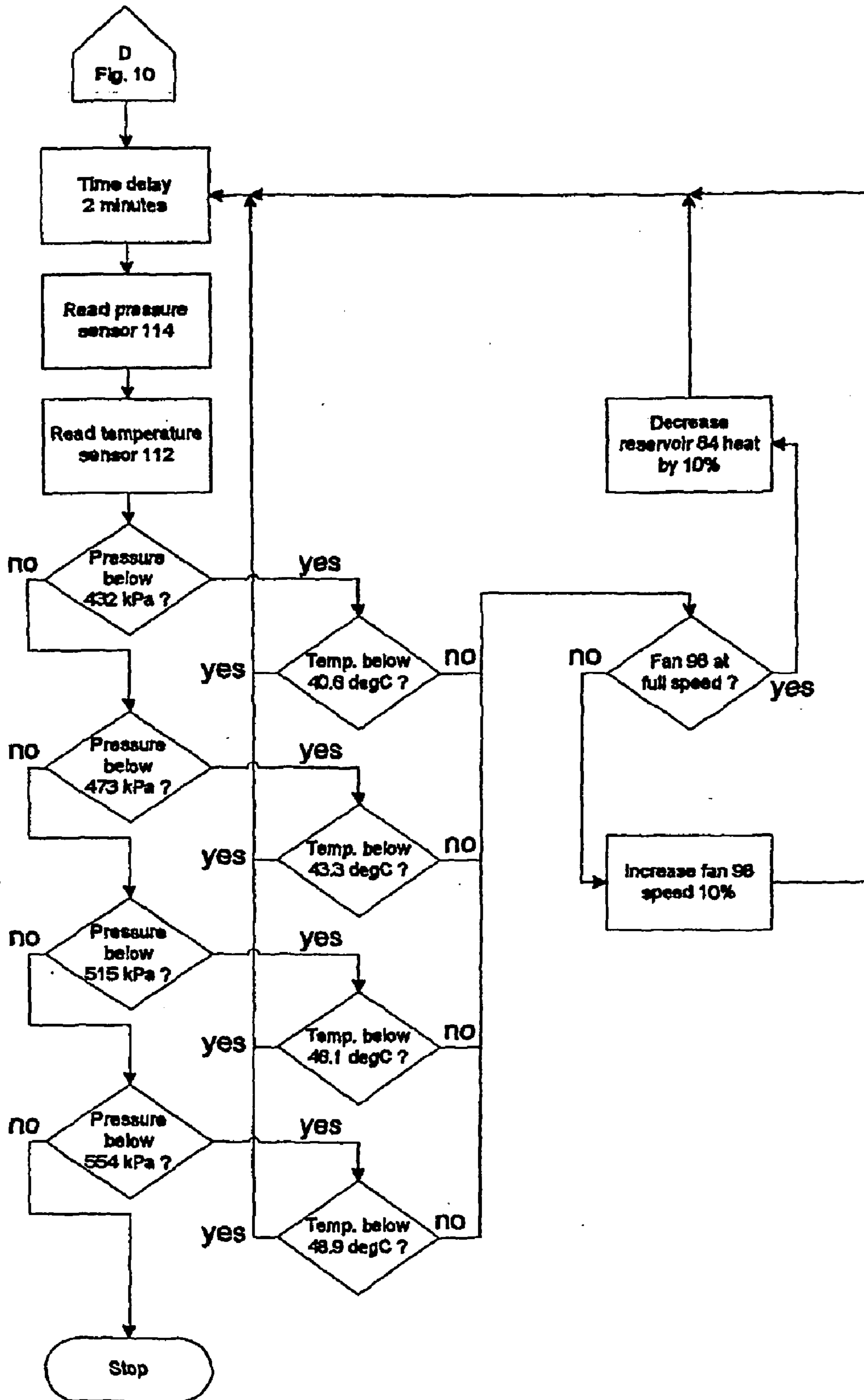
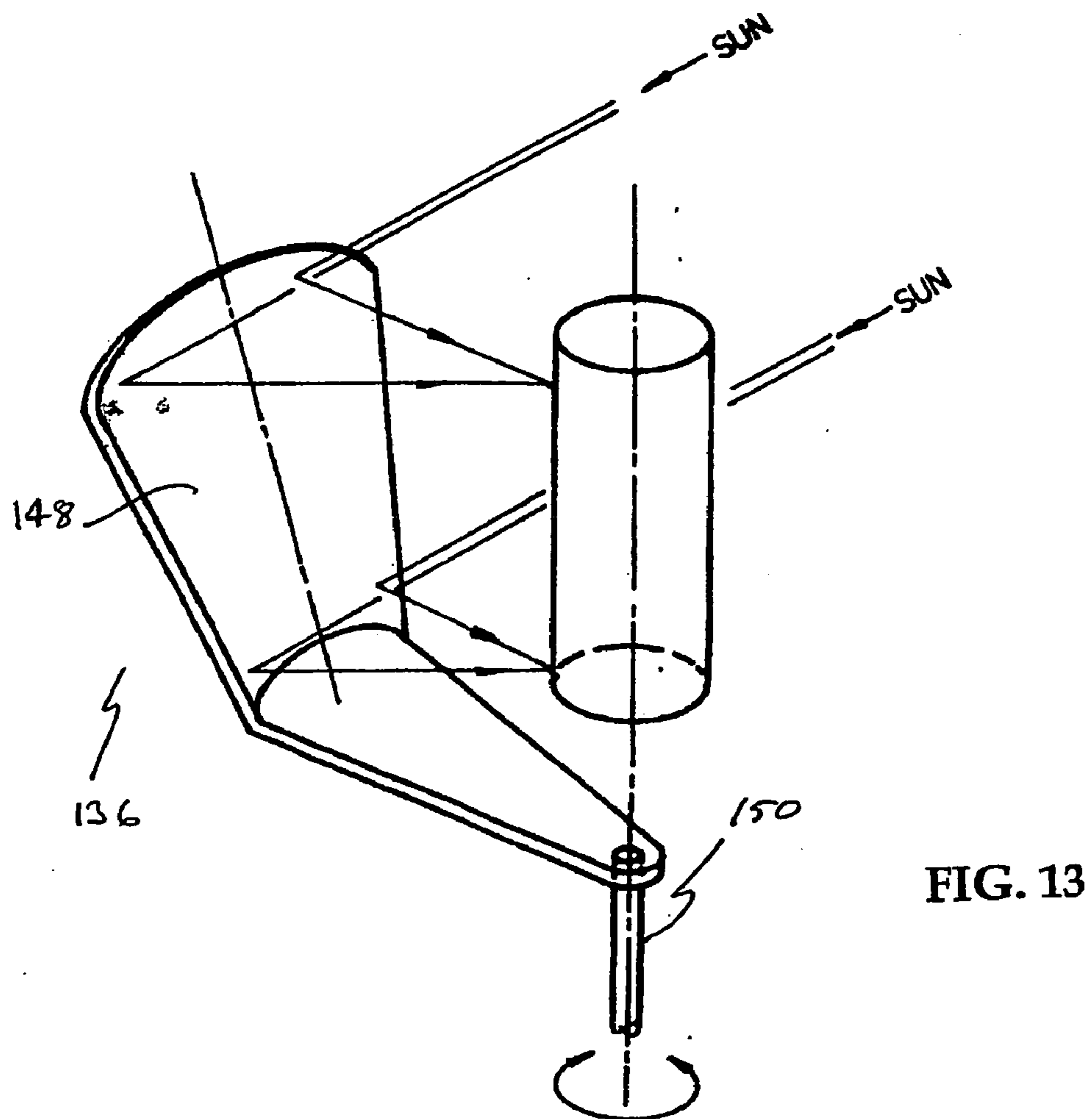
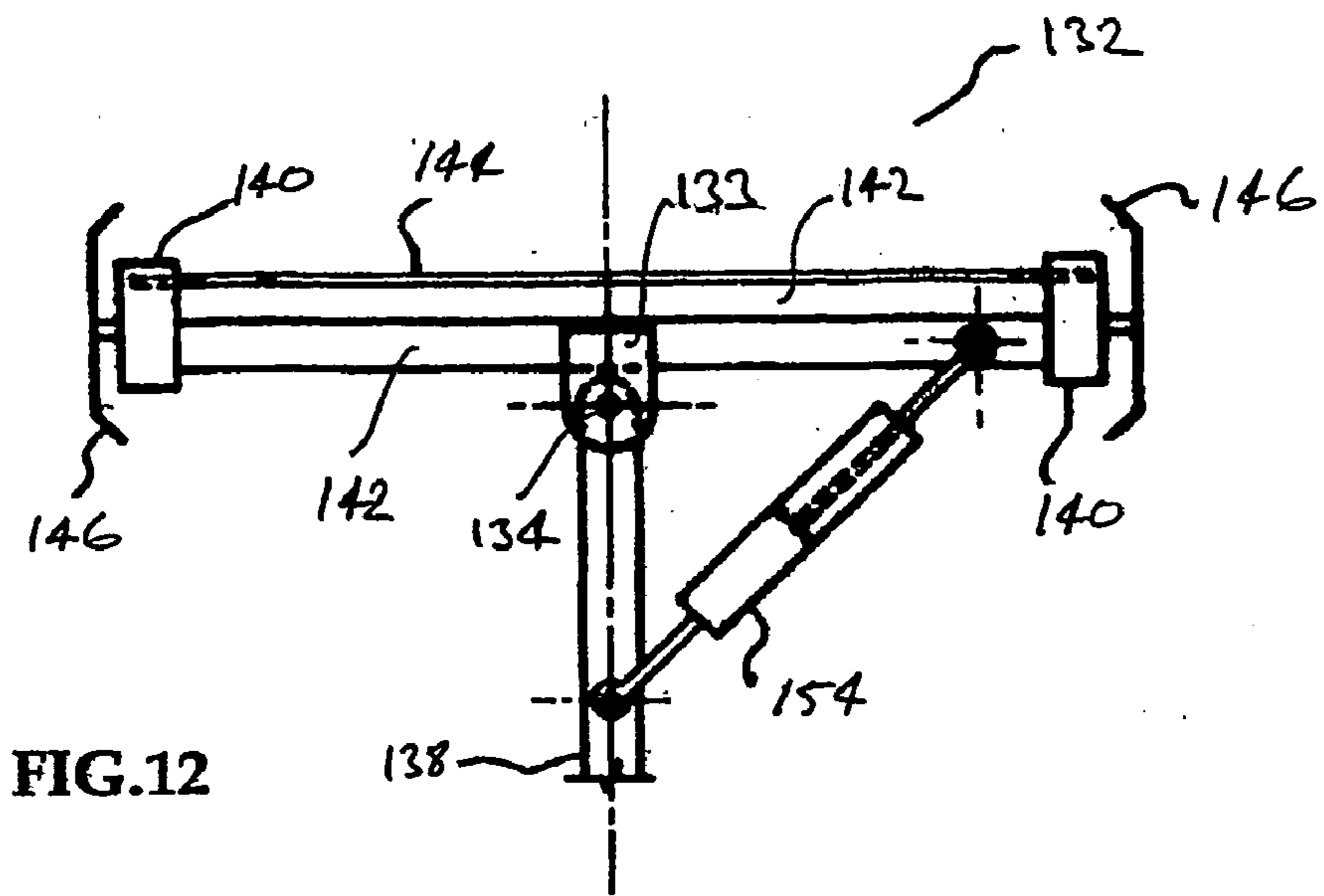

FIG. 11



METHOD AND APPARATUS FOR CONDENSING WATER FROM AMBIENT AIR

FIELD OF THE INVENTION

[0001] The present invention broadly relates to a method and apparatus for condensing water for collection from ambient air. The apparatus in at least one form provides a means for generating potable water for consumption or other purposes and finds particular application in areas where potable water supplies are limited.

BACKGROUND OF THE INVENTION

[0002] In many locations around the world access to a fresh potable water supply is limited, forcing many to use water for everyday needs that would not generally be deemed suitable for such use. Indeed, many water supplies are contaminated or polluted and in order to be able to use the water safely, it is necessary for the water to be boiled or treated in some other way.

[0003] While yachts and ships carry their own water supplies during a voyage, it is often necessary to restrict daily usage of the available water due to access to fresh water supplies other than rainfall being unavailable. Similarly, mining companies, road and rail repair gangs as well as for instance military units operating in remote locations, and island resorts all have a need for fresh water.

[0004] Water, of course, has thousands of uses in addition to being required to sustain life. Such uses include washing and use in industrial processes amongst others. In areas or locations where the supply of water is limited, it is desirable to have access to regular supplies of fresh water. While supplies can be replenished by rainwater, rainfall can be variable and insufficient. Moreover, the cost of transporting fresh water to remote locations on a regular basis can be expensive.

[0005] Apparatus for condensing water from ambient air are disclosed in European patent No. 0597716 and U.S. Pat. No. 5,857,344. Both of these apparatus comprise a refrigeration system incorporating an electric compressor, for achieving cooling of ambient air by compression and subsequent expansion of a refrigerant to effect condensation of water from the air that is then collected.

[0006] U.S. Pat. No. 6,156,102 discloses an apparatus and method for collecting water from ambient air involving passing the air into contact with a hygroscopic solution. The hygroscopic solution absorbs the moisture from the air. The moisture is subsequently evaporated from the hygroscopic solution and collected. Evaporation of the moisture is achieved by heating the hygroscopic liquid or by evaporating the moisture under vacuum. A similar arrangement involving directing ambient air into contact with a sorbent material for absorption of moisture from the air prior to subsequent separation and collection of the absorbed moisture is described in U.S. Pat. No. 6,336,957.

SUMMARY OF THE INVENTION

[0007] In an aspect of the present invention there is provided a method for collecting water from ambient air, the method comprising:

[0008] providing at least one condensation surface for contact with the ambient air;

[0009] passing a gas into an enclosed space containing a gaseous mixture of the gas and refrigerant vapour evaporated from a liquid refrigerant such that further refrigerant vapour

evaporates into the enclosed space from the liquid refrigerant, and heat is thereby drawn into the refrigerant from the condensation surface cooling the condensation surface to, or below, the dew point of the water in the ambient air;

[0010] passing the gaseous mixture from the enclosed space;

[0011] contacting the cooled condensation surface with the ambient air to effect condensation of water from the ambient air onto the condensation surface; and

[0012] collecting the condensed water.

[0013] Typically, the method will further comprise condensing the refrigerant vapour in the gaseous mixture passed from the enclosed space back into liquid refrigerant to separate the refrigerant vapour from the gas, returning the gas from the gaseous mixture to the enclosed space for generating more of the gaseous mixture, and recirculating the liquid refrigerant condensed from the gaseous mixture.

[0014] Preferably, the gaseous mixture will be passed from the enclosed space into contact with a liquid absorbent that absorbs the gas from the gaseous mixture thereby forming a solution, and the gas will be separated from the solution for the return of the gas to the enclosed space and recycling of the liquid absorbent for contact with more of the gaseous mixture.

[0015] Preferably, the liquid refrigerant condensed from the gaseous mixture is recirculated concurrently with the passage of the gas into the enclosed space and passage of the gaseous mixture from the enclosed space into contact with the liquid absorbent, such that the condensation surface is cooled in a continuous cycle.

[0016] Preferably, the liquid refrigerant will be agitated as the gas is passed into the enclosed space. Most preferably, the agitation of the liquid refrigerant will be achieved by bubbling the gas through the liquid refrigerant into the enclosed space.

[0017] Preferably, the method will further comprise monitoring temperature of ambient air flowing from the condensation surface, and adjusting the flow rate at which the ambient air flows into contact with the condensation surface to a desired flow rate to promote the condensation of the water from the ambient air onto the condensation surface.

[0018] The ambient air is cooled by contact with the condensation surface and the cooled ambient air may be used for cooling the refrigerant vapour in the gaseous mixture passed from the enclosed space, to facilitate condensing the refrigerant vapour back into the liquid refrigerant. Preferably, the gaseous mixture will be passed from the enclosed space into a condenser in which the refrigerant vapour is condensed.

[0019] Accordingly, the method may also comprise adjusting the flow rate of the ambient air flowing from the condensation surface to the condenser to promote the condensation of the refrigerant vapour. Evaluating whether the flow rate of the ambient air flowing from the condensation surface needs to be adjusted to promote the condensing of the refrigerant vapour may comprise:

[0020] measuring pressure within the condenser;

[0021] measuring temperature within the condenser; and

[0022] assessing the measured pressure and the measured temperature.

[0023] In another aspect of the present invention there is provided an apparatus for collecting water from ambient air, the apparatus comprising:

[0024] at least one condensation surface for contact with the ambient air;

[0025] an evaporator for receiving liquid refrigerant and defining an enclosed space for a gaseous mixture of refrigerant vapour evaporated from the liquid refrigerant and a gas;

[0026] an inlet opening into the evaporator for passage of the gas into the space to cause further evaporation of the liquid refrigerant into the space such that heat is drawn into the liquid refrigerant from the condensation surface, and the condensation surface is thereby cooled to, or below, the dew point of the water in the ambient air to effect condensation of water from the ambient air onto the condensation surface for collection of the water; and

[0027] an outlet for passage of the gaseous mixture from the space.

[0028] Preferably, the apparatus will further comprise a separation system for separating the gas in the gaseous mixture from the refrigerant and condensing the refrigerant vapour back into liquid refrigerant, for the return of the gas to the enclosed space in the evaporator and recycling of the liquid refrigerant.

[0029] Preferably, the separation system will comprise a condenser for receiving the gaseous mixture from the evaporator and condensing the refrigerant vapour in the gaseous mixture back into the liquid refrigerant, the condenser being adapted to receive liquid absorbent and facilitate contact of the gaseous mixture with the liquid absorbent for adsorption of the gas into the liquid absorbent to form a solution and thereby separate the gas from the refrigerant vapour.

[0030] Preferably, in use, the condenser will house a bath comprising a layer of the liquid refrigerant and a layer of the solution; and the condenser will be adapted for receiving the gaseous mixture for contact of the gaseous mixture with the liquid absorbent to form the solution, prior to passage of the solution into the bath. Generally, the liquid refrigerant will have a lower density than the solution, and the solution will separate from the layer of liquid refrigerant into the layer of the solution.

[0031] Preferably, the condenser will further comprise a mixer unit arranged within the condenser for receiving the liquid absorbent, wherein the mixer unit is adapted for creating a flow of the liquid absorbent over a surface of the mixer unit for facilitating the contact of the gas with the liquid absorbent. Generally, the mixer unit will incorporate an open well for receiving the liquid absorbent and providing the flow of the liquid absorbent down the surface of the mixer unit with overflow of the liquid absorbent from the well.

[0032] Preferably, the mixer unit will be adapted for promoting turbulence in the liquid absorbent as the liquid absorbent flows down the surface of the mixer unit to enhance absorption of the gas by the liquid absorbent. Typically, the mixer unit will have at least one ridge defined in the surface of the mixer unit and which lies across the surface for promoting the turbulence in the liquid absorbent. Preferably, the mixer unit will have a plurality of ridges, the ridges being spaced apart from one another down the mixer unit and extending substantially entirely around the outer periphery of the mixer unit.

[0033] Preferably, the mixer unit will be mounted on gimbals arranged within the condenser for maintaining the mixer unit in a substantially upright position.

[0034] Preferably, the separation system will further comprise a separation reservoir for evaporation of the gas from the liquid absorbent, the separation reservoir comprising:

[0035] a housing;

[0036] an inlet for passage of the liquid absorbent into the housing, the gas evaporating from the liquid absorbent within the housing; and

[0037] an outlet for return of the gas evaporated from the liquid absorbent to the evaporator.

[0038] The separation reservoir will typically be adapted for being heated to facilitate evaporation of the gas from liquid absorbent.

[0039] Preferably, the separation system will further comprise a pump system for elevating the liquid absorbent to an elevated position for flow of the liquid absorbent to the condenser for contact with further of the gaseous mixture from the evaporator, the pump system comprising:

[0040] a heating reservoir for receiving the liquid absorbent and being heated for causing the liquid absorbent to be forced from the heating reservoir;

[0041] a riser tube for receiving the liquid absorbent from the heating reservoir upon the heating reservoir being heated; and

[0042] a collection reservoir arranged at the elevated position and into which the tube opens for collection of the liquid absorbent, the collection reservoir being adapted for passage of the liquid absorbent from the collection reservoir to the condenser.

[0043] Preferably, the collection reservoir will have a first outlet for passage of the liquid absorbent from the collection reservoir to the condenser, an interior space for receiving the gas together with absorbent vapour which evaporate from the liquid absorbent with travel along the riser tube, and a further outlet for passage of the gas separated from the liquid absorbent from the collection reservoir to the evaporator.

[0044] Preferably, the first outlet of the collection reservoir will open into a conduit for directing the liquid absorbent to the condenser, wherein the conduit passes through the separation reservoir for heat exchange with the solution from the condenser.

[0045] Preferably, the further outlet of the collection reservoir will open into a passageway connecting the first outlet of the separation reservoir with the evaporator. The passageway will desirably have an inclined region for trapping liquid absorbent that condenses in the passageway from the absorbent vapour, and draining the condensed liquid absorbent into the separation reservoir.

[0046] Preferably, the apparatus will also comprise a heat exchanger for heat exchange between the gaseous mixture and the gas with passage of the gaseous mixture from the space in the evaporator to the condenser and passage of the gas from the separation system to the evaporator. Generally, the heat exchanger will usually also be adapted for receiving the condensed refrigerant for heat exchange with the gaseous mixture and the gas, with passage of the condensed refrigerant from the condenser to the evaporator.

[0047] Moreover, the apparatus will preferably comprise a casing housing the condenser and the evaporator, for directing the ambient air from the evaporator into contact with the condenser. Preferably, a fan will be provided for producing flow of the ambient air through the casing from exterior of the casing. More preferably, the condensation surface will usually be arranged at an angle relative to horizontal for facilitating the collection of the condensed water. The angle will typically be in a range from about 30° C. to about 60° C. and preferably, from about 40° C. to about 50° C.

[0048] Preferably, the apparatus will also comprise a control system for controlling flow rate of the ambient air into contact with the condensation surface, the control system comprising:

[0049] a temperature sensor for determining temperature of the ambient air flowing from the condensation surface;

[0050] wherein the control system is adapted to monitor the temperature determined by the temperature sensor and adjust the flow rate of the ambient air flowing into contact with the condensation surface to promote condensation of the water from the ambient air onto the condensation surface.

[0051] Preferably also, the apparatus will be adapted to direct the ambient air flowing from the condensation surface to the condenser, and wherein the control system will further comprise an adjustable air intake operable to adjust flow rate of the ambient air flowing from the evaporator to the condenser relative to the flow rate of the ambient air flowing into contact with the condensation surface, to thereby alter temperature and pressure within the condenser to promote the condensation of the refrigerant vapour.

[0052] Most preferably, the control system will comprise a further temperature sensor for measuring temperature in the condenser, and a pressure sensor for measuring pressure within the condenser, and the control system will be further adapted to assess the temperature measured by the further temperature sensor and the pressure measured by the pressure sensor, and operate the adjustable air intake to alter the flow rate of the ambient air flowing to the condenser.

[0053] Preferably, the inlet opening into the evaporator will be located for bubbling the gas through the liquid refrigerant into the enclosed space of the evaporator. Bubbling the gas through the liquid refrigerant agitates the liquid refrigerant increasing heat transfer from the ambient air to the liquid refrigerant.

[0054] In yet another aspect of the present invention there is provided an evaporator for effecting condensation of water from ambient air, the evaporator comprising:

[0055] at least one condensation surface for contact with the ambient air;

[0056] a housing for receiving liquid refrigerant and having an interior enclosed space for a gaseous mixture of refrigerant vapour evaporated from the liquid refrigerant and a gas;

[0057] an inlet for passage of the gas into the space to cause further evaporation of the liquid refrigerant into the enclosed space such that heat is drawn into the liquid refrigerant from the condensation surface and the condensation surface is thereby cooled to, or below, the dew point of the water in the ambient air to effect condensation of the water from the ambient air onto the condensation surface for collection of the water; and

[0058] an outlet for passage of the gaseous mixture from the enclosed space.

[0059] Preferably, the, or each, condensation surface will be a surface of a cooling fin respectively, and the housing of the evaporator will comprise:

[0060] an upper region for receiving the gaseous mixture of the gas and the refrigerant vapour;

[0061] a lower region for being at least partly filled with the liquid refrigerant and being spaced from the upper region; and

[0062] at least one conduit that opens at one end into the upper region of the housing and at an opposite end into the lower region; and

[0063] wherein the, or each, cooling fin is arranged between the upper region and the lower region for contact with the ambient air.

[0064] Typically, a plurality of cooling fins will be spaced apart from each other and arranged one next to another for contact with the ambient air.

[0065] In yet another aspect there is provided a method for separating a gas from a refrigerant vapour in a gaseous mixture, the method comprising:

[0066] providing a condenser adapted for condensing the refrigerant vapour into liquid refrigerant, the condenser housing a mixer unit for receiving a liquid absorbent for absorbing the gas and which is adapted for facilitating contact of the liquid absorbent with the gaseous mixture;

[0067] passing the gaseous mixture into the condenser to effect the condensing of the refrigerant vapour; and

[0068] passing the liquid absorbent to the mixer unit whereby the liquid absorbent contacts the gaseous mixture such that the gas is absorbed into the liquid absorbent forming a solution of the liquid absorbent and the gas.

[0069] In a further aspect there is provided a condenser for separating a gas from a refrigerant vapour in a gaseous mixture, the condenser comprising:

[0070] a housing for receiving the gaseous mixture and condensing the refrigerant vapour into liquid refrigerant; and

[0071] a mixer unit arranged within the housing for receiving a liquid absorbent for absorbing the gas to form a solution of the gas and the liquid absorbent, the mixer unit being adapted for facilitating contact of the gaseous mixture with the liquid absorbent.

[0072] In still another aspect of the present invention there is provided a mixer unit for mixing a gas with a liquid absorbent for absorbing the gas from a gaseous mixture of the gas and a refrigerant vapour to separate the gas and the refrigerant vapour, the mixer unit comprising:

[0073] a mixer body for receiving the liquid absorbent and facilitating contact of gaseous mixture with the liquid absorbent for absorption of the gas, the mixer body being adapted for facilitating contact of the gaseous mixture with the liquid absorbent.

[0074] Condensing water from ambient air provides a way of supplementing fresh or stored water supplies in remote or extreme locations where fresh water is scarce or otherwise unavailable, and may reduce reliance on, or the need for, water to be transported to such locations. Similarly, where it is necessary to carry water supplies such as on a ship or boat during a voyage, condensing water from ambient air provides an alternative source of water during travel and so allows less reliance to be placed on stored water. Indeed, by being able to condense water from the ambient air, stores of carried water may be reduced. In addition, condensing water from air provides some certainty as to the quality of the water and so provide a source of water in areas where there is doubt as to the quality of the existing water supplies or the available water is known to be polluted or contaminated, or is otherwise not suitable for the intended purpose of the water. Accordingly, one or more embodiments of the present invention find application in a number of practical situations.

[0075] Moreover, as the ambient air is cooled and heat is generated when the refrigerant vapour is condensed during the operation of apparatus described herein, the cooled ambient air and generated heat may be used for general cooling and heating purposes, respectively.

[0076] Accordingly, in a yet further aspect of the present invention there is a method for providing heating from an apparatus during operation of the apparatus, the method comprising:

[0077] passing a gas into an enclosed space containing a gaseous mixture of the gas and refrigerant vapour evaporated from a liquid refrigerant, such that further refrigerant vapour evaporates into the enclosed space from the liquid refrigerant;

[0078] passing the gaseous mixture from the enclosed space to a condenser for condensing the refrigerant vapour in the gaseous mixture back into liquid refrigerant;

[0079] returning the gas from the gaseous mixture to the enclosed space;

[0080] recirculating the liquid refrigerant condensed from the gaseous mixture for evaporation into the enclosed space; and

[0081] drawing off heat from the condenser to provide the heat.

[0082] In still another aspect of the present invention there is a method for providing cooling from an apparatus during operation of the apparatus, the method comprising:

[0083] providing at least one cooling surface for contact with ambient air;

[0084] passing a gas into an enclosed space containing a gaseous mixture of the gas and refrigerant vapour evaporated from a liquid refrigerant, such that further refrigerant vapour evaporates into the enclosed space from the liquid refrigerant, and heat is thereby drawn into the liquid refrigerant from the cooling surface cooling the cooling surface;

[0085] passing the gaseous mixture from the enclosed space;

[0086] contacting the cooled cooling surface with the ambient air to effect cooling of the ambient air; and

[0087] using the cooled ambient air to provide the cooling.

[0088] Apparatus for providing the heating and/or cooling are also specifically encompassed by the present invention. It will be understood that it is not necessary that the condensation/ cooling surface(s) of apparatus provided for general heating and cooling purposes be cooled to, or below, the dew point of the ambient air. That is, the heating or cooling can be achieved without collection of water from the ambient air.

[0089] Throughout this specification the word "comprise" or variations such as "comprises" or "comprising" will be understood to imply the inclusion of a stated element, integer or step, or group of elements, integers or steps, but not the exclusion of any other element, integer, or step, or group of elements, integers or steps.

[0090] The features and advantages of the present invention will become further apparent from the following description of the preferred embodiments of the present invention together with the accompanying drawings.

BRIEF DESCRIPTION OF THE FIGURES

[0091] FIG. 1 is a plan view of apparatus embodied by the present invention for condensing water from ambient air;

[0092] FIG. 2 is a side view of the apparatus of FIG. 1;

[0093] FIG. 3 is a schematic view illustrating the operation of the apparatus of FIG. 1;

[0094] FIG. 4 is a rear view of the evaporator of the apparatus of FIG. 1;

[0095] FIG. 5 is a partial longitudinal cross-sectional view of the condenser of the apparatus of FIG. 1;

[0096] FIG. 6 is a cross-sectional view taken through B-B of the condenser of FIG. 5;

[0097] FIG. 7 is a schematic view of a control system of the apparatus of FIG. 1;

[0098] FIG. 8 is a schematic view illustrating the operation of a further apparatus embodied by the present invention for condensing water from ambient air; and

[0099] FIGS. 9 to 11 are flow diagrams illustrating the control system of the apparatus illustrated in FIG. 8.

[0100] FIG. 12 is a schematic end view of a solar heat tracking apparatus for providing heating.

[0101] FIG. 13 is a schematic view showing heating being effected by the reflector of the apparatus of FIG. 12.

DETAILED DESCRIPTION OF PREFERRED EMBODIMENTS

[0102] The apparatus 2 of FIG. 1 comprises an evaporator 4 containing iso-butane (R600a) refrigerant for cooling the evaporator to or below the dew point of water in ambient air flowing through the evaporator in use. Briefly, the cooling of the evaporator is achieved by passing a gas such as ammonia that is substantially inert with respect to the refrigerant into a headspace of the evaporator. This lowers the partial pressure of refrigerant vapour in the headspace and thereby causes further refrigerant to evaporate from the liquid refrigerant into the headspace. The resulting gaseous mixture in the headspace comprising the gas and the refrigerant vapour; passes from the evaporator and the gas and the refrigerant vapour are separated. The separated refrigerant vapour is condensed, and the gas and condensed liquid refrigerant are recirculated back to the evaporator 4 in a continuous cycle.

[0103] As shown more clearly in FIG. 2, the gaseous mixture from the evaporator 4 passes to a condenser 6 due to a pressure differential between the evaporator and the condenser. The separation of the gas from the refrigerant vapour occurs in the condenser and is achieved by contacting the gas within the gaseous mixture with a liquid absorbent fed into the condenser. The gas is absorbed by the liquid absorbent to form a solution which passes from the condenser to a separation reservoir for separation of the gas from the solution prior to the return of the gas to the evaporator. The liquid absorbent separated from the solution is recirculated by a pump system generally indicated by the numerals 8 and 10 to the condenser for further separation of gas from the gaseous mixture entering the condenser from the evaporator.

[0104] As shown schematically in FIG. 3, the evaporator 4 comprises a housing 12 having a lower chamber 14 which is in fluid communication with a headspace 16 of the evaporator through a plurality of spaced apart rows of tubular pipes 18. The evaporator 4 is filled with liquid iso-butane refrigerant 28 except for the headspace 16 of the evaporator. Spaces 20 between the pipes provide a pathway for ambient air to flow through the evaporator over cooling fins 22. The upper side 22a and under side 22b of each fin 22 provide condensation surfaces for the condensation of water from the ambient air. The evaporator and thereby the fins 22 are arranged at a 45° angle relative to horizontal such that the condensed water runs off the fins and falls onto a sloping surface of a casing 24 housing the evaporator and the condenser, which directs the water to an outflow spigot 26 for collection as illustrated in FIG. 2.

[0105] The gas 30, in this instance ammonia gas, is bubbled through the liquid refrigerant from an inlet in the form of a diffuser 32 arranged within the lower chamber 14 of the evaporator. The ammonia gas passes up through the pipes 18 into the headspace 16 of the evaporator where it mixes with

refrigerant vapour that has evaporated from the underlying liquid refrigerant. The entry of the ammonia gas into the headspace causes the partial pressure of the refrigerant vapour to decrease. This causes further refrigerant to evaporate from the liquid refrigerant in the evaporator. As a result, heat is drawn into the liquid refrigerant from the cooling the fins 22 which in turn cools ambient air flowing over the fins.

[0106] An outlet 34 is provided in the headspace 16 of the evaporator through which the gaseous mixture flows to the condenser 6 through a feed pipe 36. The feed pipe 36 opens into an upper region 38 of the condenser through an inlet 40. The condenser 6 is partly filled with a bath in a bottom region 43 of the condenser, comprising a layer of liquid refrigerant 28 overlaying a layer of a solution 42 of water and dissolved ammonia gas. A mixer unit 44 is suspended within the upper region of the condenser by dual axis gimbals 46 secured to the walls of the condenser. The gimbals ensure that the mixer unit remains in a substantially upright position if the ground surface on which the apparatus 2 is located is not horizontal.

[0107] A well 48 defined in an upper end of the mixer unit receives the liquid absorbent 50 from a further inlet 52 provided in the upper region 38 of the condenser. The liquid absorbent comprises water containing a substantially lower concentration of dissolved ammonia gas than the solution 42 in the bottom region of the condenser. The liquid absorbent 50 overflows from the rim 54 of the well and down the outer peripheral surface 56 of the mixer unit prior to falling into the layer of liquid refrigerant 28 of the bath.

[0108] As the liquid absorbent travels down the outer peripheral surface of the mixer unit under the effect of gravity, it contacts the gaseous mixture entering the condenser from the evaporator and absorbs ammonia from the gaseous mixture. As shown in FIG. 5, the mixer unit is provided with a plurality of spaced apart circumferential ridges 58 which form annular rings around the mixer unit. The rings produce turbulence in the flow of the liquid absorbent down the mixer unit as the absorbent passes over each one. The turbulence facilitates mixing of the liquid absorbent with the ammonia gas in the gaseous mixture from the evaporator and thereby, absorption of the ammonia gas into the liquid absorbent. A cross-sectional view taken through B-B of the mixer unit is shown in FIG. 6. As can be seen, the liquid absorbent falls into the centre of the well 48 through aperture 60 of the inlet 52.

[0109] Returning to FIG. 3, the liquid absorbent and dissolved ammonia gas has a higher density than the liquid refrigerant, and so settles from the layer of the liquid refrigerant into the solution 42 in the bottom region 43 of the condenser.

[0110] The solution 42 flows from the condenser through a feed pipe 62 and enters the separation reservoir 64 through an inlet 66. The storage reservoir 64 is partially filled with a solution of the liquid absorbent and dissolved ammonia gas, and has an internal headspace 68 filled with vapour from the solution and more particularly, ammonia gas and water vapour. In use, the separation reservoir is heated forcing the majority of the ammonia gas in the solution entering from the condenser to evaporate into the internal headspace 68 of the separation reservoir.

[0111] An outlet 70 is provided in the separation reservoir through which the weaker solution 41 flows to a heating reservoir 72 of the pump system through a feed pipe 74. The heating reservoir 72 is heated to a sufficient temperature, typically the boiling point of the weaker solution, to force the weaker solution up through riser tube 76 into collection res-

ervoir 78. As the heated solution "percolates" up the riser tube 76 water vapour and ammonia gas evaporate from the solution, forming pockets of gas which are driven up through the riser tube with passage of the solution to the collection reservoir 78. The solution entering the collection reservoir therefore has a lower concentration of dissolved ammonia gas compared to both the solution 42 entering the separation reservoir and the solution passing from the storage reservoir to the heating reservoir.

[0112] After entering the collection reservoir 78, the solution is recirculated to the condenser 6 as the liquid absorbent 50 for absorbing further ammonia gas from the gaseous mixture passing into the condenser 6 from the headspace 16 of the evaporator 4 through feed pipe 36.

[0113] More particularly, as indicated in FIG. 3, the liquid absorbent 50 exiting the riser tube 76 pools within the collection reservoir 78 and travels back down recycling tube 80 which passes through the solution 42 in the separation reservoir 64 in a heat exchange relationship with the inlet 66, for heat exchange with the solution entering the separation reservoir from the condenser. From the storage reservoir, the recycling tube 80 directs the liquid absorbent to inlet 52 of the condenser.

[0114] A feed pipe 82 feeds the ammonia gas and water vapour entering the collection reservoir from riser tube 76 to a common feed pipe 84 which opens at one end into the headspace 68 of the separation reservoir through outlet 86. An opposite end of the common feed pipe 84 opens into the diffuser 32 arranged in the evaporator 4 for return of the ammonia gas to the headspace 16 of the evaporator. The common feed pipe 84 has an inclined section 88 for trapping water which condenses in the common feed pipe from water vapour entering with ammonia gas from the collection reservoir 78 and separation reservoir 64, and directing the condensed water back to the storage reservoir.

[0115] As also indicated in FIG. 3, the common feed pipe 84 passes through a heat exchanger 90 comprising a section of the feed pipe 36 transporting the gaseous mixture from the headspace 16 of the evaporator 4 to the condenser 6. A further feed pipe 92 recycling condensed refrigerant 28 from the condenser to the lower chamber 14 of the evaporator 4 also passes through the heat exchanger 90 and continues on in a heat exchange relationship with the common feed pipe 84 from the heat exchanger 90 to the lower chamber 14 of the evaporator 4. As will be appreciated, the heat exchanger 90 facilitates heat exchange between the gaseous mixture in the heat exchanger and the refrigerant in feed pipe 92 and the ammonia gas in the common feed pipe 94. Similarly, the side by side arrangement of the common feed pipe 84 and feed pipe 92 from the heat exchanger 90 to the evaporator 4 allows for heat exchange between the refrigerant in feed pipe 92 and the ammonia gas in the common feed pipe.

[0116] As described above, the evaporator 4 and condenser 6 are housed within a casing 24. As best illustrated in FIG. 7, the casing 24 has a main air intake 96 and a fan 98 arranged at an outlet 100 for drawing ambient air into the casing from the atmosphere through the main air intake. The ambient air flows through the evaporator into contact with the cooling fins 22 causing water to condense from the air onto the fins 22, and then into contact with the housing 94 of condenser 6. As the cooled air passes over the housing of the condenser, heat is drawn off from the housing. The refrigerant vapour in the upper region of the condenser and the underlying liquid refrigerant are thereby also cooled.

[0117] For efficient operation, the flow rate of the ambient air through the casing 24 is adjusted to optimise condensation of water per unit volume of the ambient air flowing through the evaporator, while maintaining sufficient air flow over the condenser for heat transfer from the condenser to the ambient air for condensation of the refrigerant vapour within the condenser. As will be understood, the apparatus is operated such that the cooling fins are sufficiently cooled without freezing the condensed water.

[0118] For any given prevailing atmospheric conditions, there is a specific humidity value measured in grams of water vapour per kilogram of the air. For example, a specific humidity of between 4.5 and 6 grams of moisture per kilogram of air correlates to a dry bulb temperature of between 1° C. and 6.5° C. In use, the apparatus is operated at such that the specific humidity of the ambient air flowing from the condensation surfaces of the cooling fins 22 is reduced to a specific humidity correlating with a specific selected dry bulb temperature or temperature range.

[0119] More particularly, the fan 98 is initially operated at maximum speed to achieve maximum air flow through the casing 24 and the dew point of the ambient air entering the evaporator is determined by a sensor 102. The sensor is arranged so as to be progressively cooled by the ambient air as the ambient air entering the evaporator is cooled by the cooling fins 22. When condensation forms on the sensor 102 from the ambient air, the sensor is short circuited indicating the dew point of the ambient air. This temperature is compared in control module 106 to the dry bulb temperature of the air leaving the evaporator measured by a temperature sensor 104. If the temperature measured by temperature sensor 104 is above the dew point of the water in the ambient air determined by sensor 102, the speed of the fan is progressively reduced on command from the control module 106 lowering the flow rate of the ambient air through the evaporator. This continues until the temperature of the ambient air is lowered to the dew point of the water in the ambient air to achieve condensation of the water onto the cooling fins 22.

[0120] Once the optimum flow rate of the ambient air over the evaporator 4 has been achieved, the temperature of the condensed refrigerant 28 in the condenser 6 is measured by a further temperature sensor 112 and compared in the control module 106 with the total pressure in the upper region 38 of the condenser measured by pressure sensor 114. As the pressure in the upper region of the condenser varies according to ambient conditions, there are temperature and pressure conditions within the condenser for optimum condensation of the refrigerant vapour.

[0121] The temperature and pressure measured by the temperature sensor 112 and pressure sensor 114 are compared in control module 106 and the control module determines whether the optimum conditions for condensation of the refrigerant vapour have been achieved. If the control module determines that the temperature in the condenser is too high for the condensation of the refrigerant vapour, the speed of the fan 98 is progressively increased on command from the control module. This increases the flow rate of the cooled ambient air passing from the evaporator to the condenser, causing further heat to be removed from the housing of the condenser by the ambient air and the temperature in the condenser to thereby be progressively lowered. The speed of the fan continues to be increased until a temperature in the condenser at which condensation of the refrigerant vapour occurs has been reached.

[0122] After a short time delay of typically 1 to 2 minutes, the dew point of the ambient air entering the evaporator and the dry bulb temperature of the ambient air leaving the evaporator are again measured by temperature sensors 102 and 104, and those temperatures are compared in the control module. If a temperature measured by the temperature sensor 104 has risen above the dew point of the water, an air-intake in the form of a hinged by-pass damper 108 arranged in a lower region of the casing 24 is opened to at least a limited extent by an actuator 110 operated by the control module. The opening of the by-pass damper 108 allows uncooled ambient air indicated by the arrow, to flow into the casing through the further air-intake into contact with the condenser. This reduces the flow rate of the ambient air through the evaporator to that required for cooling of the ambient air to the dew point of the water in the ambient air, while maintaining or increasing the flow rate of the ambient air past the condenser.

[0123] The control module 106 continues to monitor the temperatures of the air flow of the ambient air through the casing measured by temperature sensors 102 and 104, as well as the temperature of the liquid refrigerant in the condenser and the total pressure in the upper region of the condenser measured by pressure sensor 114 and temperature sensor 112, and to adjust the position of the damper 108 and the speed of the fan 98 in response to changing ambient conditions as required for continued condensation of water from the ambient air onto the cooling fins 22 and condensing of the refrigerant vapour within the condenser 6. The monitoring cycle is repeated at regular intervals to ensure optimum efficiency of the apparatus and thereby, maximum production of water from the ambient air. The timing circuit for initiating operation of the monitoring cycle is also located within the control module. Such control circuitry is well within the scope of the skilled addressee.

[0124] A further apparatus for collecting water from ambient air embodied by the present invention is illustrated schematically in FIG. 8. This apparatus differs from that illustrated in FIG. 3 in that the pump system comprising the heating reservoir 72 and the collection reservoir 78 is located before the separation reservoir 64. More particularly, the solution 42 from the condenser 6 flows directly into the heating reservoir 72 where it is heated for separation of dissolved ammonia gas from the liquid absorbent. As described above, as the heated solution 42 “percolates” up the riser tube 76, water vapour and ammonia gas evaporate from the solution, forming pockets of the gas which are driven up through the riser tube into the collection reservoir. As with the embodiment illustrated in FIG. 3, the liquid absorbent 50 which collects in the collection reservoir is channelled back into the condenser 6 through recycling tube 80 for contact with further gaseous mixture passing from the evaporator 4. However, rather than the separated gas being channelled to diffuser 32 in the evaporator as in the embodiment shown in FIG. 3, the separated ammonia gas passes through feed pipe 82 into the upper region 38 of the condenser. This minimises the passage of water vapour evaporated from the liquid absorbent passing into the evaporator.

[0125] The solution of the liquid absorbent and remaining dissolved ammonia gas that passes from the heating reservoir 72 to the separation reservoir is heated in separation reservoir 64 as above, to effect evaporation of the ammonia gas for return of the gas to the diffuser 32 in the evaporator through feed pipe 84.

[0126] As further shown in FIG. 8, this apparatus also incorporates a water return system 116 for returning water which accumulates in the evaporator 4 to the condenser 6. The water return system comprises a float valve incorporating a ball float 118 arranged in a storage cylinder 120 which opens into the evaporator through feed conduit 122. The ball float 118 normally rests on the open end 124 of the drain conduit 126, thereby closing the drain conduit. A pressure equalising conduit (not shown) connects the upper region of the storage cylinder above the ball float 118 to a lower region of the storage cylinder below the ball float. The density of water is greater than that of the refrigerant and so settles to the bottom of the storage cylinder. The ball float has a density such that it will not float in the refrigerant but will float in the water. When sufficient water accumulates in the bottom of the storage cylinder 120, the ball float is lifted from the drain conduit 126, allowing water to flow into the drain conduit to water return heating reservoir 128, until the level of the water in the storage cylinder decreases such that the ball float returns to its normal position sealing the open end 124 of the drain conduit preventing the escape of liquid refrigerant from the evaporator.

[0127] In use, the water return heating reservoir 128 is heated by an electric element in use forcing the water to percolate up water return pipe 130 which empties into the condenser 6. As will be appreciated, the water which collects in the storage cylinder 120 from the evaporator will contain an amount of dissolved ammonia gas. It will also be understood that the apparatus shown in FIG. 3 may also be provided with a water return system 116.

[0128] Flow diagrams illustrating operation of the control system of the apparatus of FIG. 8 are shown in FIG. 9 to FIG. 11. In this control system, temperature sensor 102 has been omitted and the flow of ambient air into contact with the cooling fins 22 of the evaporator is varied to maintain the temperature measured by temperature sensor 104 at a temperature in a range of from 4° C. to 5° C. At the commencement of operation of the apparatus, the solution in each of water reservoir 128, separation reservoir 64 and heating reservoir 72 is heated to from 90° C. to 95° C. by respective electric heating elements. The by-pass damper 108 is in a closed position and the fan 98 is operated at maximum speed. The temperature measured by the temperature sensor 104 is then measured at approximately 2 minute intervals and the speed of the fan is varied, or the by-pass damper 108 is opened, in 10% increments until the temperature measured by the temperature sensor is within the range of from 4° C. to 5° C. If with further monitoring, the temperature measured falls below 4° C. and the by-pass damper 108 is fully open, heating of the solution in separation reservoir 64 is reduced in 10% increments corresponding to decrease of about 9° C. each time. This reduces the rate of evaporation of the ammonia gas from the solution in the separation reservoir and thereby, the amount of ammonia gas returning to the evaporator via the diffuser 32 of the evaporator 4 causing the temperature of the cooling fins 22 to rise. Alternatively, the speed of the fan 98 can also be increased in order to raise the temperature measured by the temperature sensor 104.

[0129] The temperature of the condensed liquid refrigerant and the pressure within the condenser 6 are separately monitored at approximately 2 minute intervals by temperature sensor 112 and pressure sensor 114. If the determined pressure and temperature are not at predetermined levels for effecting condensation of refrigerant vapour in the condenser, the speed of the fan is increased in 10% increments or alter-

natively, the heating of the solution in the separation reservoir 64 is decreased in 10% increments, until the temperature and pressure measured by temperature sensor 112 and pressure sensor 114 are below the predetermined levels. For the combination of ammonia gas and iso-butane refrigerant as utilised in the embodiments shown in FIGS. 3 and 8, the pressure within the condenser will generally be maintained below 432 kPa while the temperature of the condensed liquid refrigerant will generally be maintained below 40.6° C. However, it will be appreciated that different temperature and pressure settings will be required when system gas and refrigerant other than ammonia gas and iso-butane refrigerant are utilised.

[0130] The power for driving the operation of the electrical components of the apparatus embodied by the invention such as the fan 98 is preferably provided by mains electricity. However, instead, or as well, apparatus may be provided with a solar panel comprising arrays of photovoltaic cells for providing sufficient electricity to meet the entire energy requirements of the apparatus, including all heating requirements and driving the fan 98 and control module 106. In this instance, the apparatus will typically also be provided with one or more rechargeable batteries and a recharging circuit for recharging the battery or batteries using electrical energy generated by the solar panel. Such recharging systems are well known in the art.

[0131] Alternatively, a solar heating apparatus 132 with a tracking mechanism for tracking solar heat such as the type illustrated in FIG. 12 and FIG. 13 may be utilised to provide heating for a water condenser apparatus embodied by the invention. The tracking mechanism comprises a balance 133 on which a parabolic reflector 136 is mounted. The balance incorporates a frame pivotally mounted on a stand 138. The frame consists of hollow side tanks 140 approximately half filled with a liquid refrigerant such as freon, and opposite end members 142. The interiors of the tanks are connected together through the passageway of a hollow feed tube 144. A shade panel 146 lies along each side tank for shading the corresponding tank from behind. A reflective surface on a front side of each shade panel reflects heat onto the corresponding tank when the tank is facing the sun.

[0132] The side tanks 140 are arranged such that in use, a first of the tanks is exposed to the sun to a greater degree than the second of the tanks. As the first tank is heated by the sun, the pressure in the tank increases creating a pressure differential between the tanks, and freon progressively flows from the first tank to the other through feed tube 144. As the freon flows into the second tank, the weight of the second tank becomes heavier than the first, causing the frame of the balance to pivot about a pivot pin 134 and the reflector to be moved in a western direction substantially synchronously with the movement of the sun.

[0133] As shown more dearly in FIG. 13, a flexible drive shaft 150 is rotated about its longitudinal axis with rotation of the frame about the pivot pin. More specifically, the drive shaft 150 is secured at one end about the pivot pin 134, and carries reflector 136 on an opposite end. The opposite end of the drive shaft 150 is arranged so as to be substantially concentric with the longitudinal axis of the component of the water condenser apparatus to be heated. The reflector 136 is thereby rotated about the component to be heated with rotation of the drive shaft 150.

[0134] The rear reflective surface 148 of the reflector 136 is inclined relative to the axis of rotation of the drive shaft. As the rear reflective surface is inclined, the focal length of the

reflector varies from the top of the reflector to the bottom of the reflector. This enables the reflector to focus sunlight impinging on the reflector onto the component to be heated when the sun is in different positions throughout the day. The component to be heated may for instance comprise the separation reservoir **64**, heating reservoir **72** or water return heating reservoir **128**. Alternatively, a combination of one or more of these may be heated. In this latter instance, the reservoirs may be arranged adjacent to each other for being heated by an appropriately dimensioned reflector **136**.

[0135] At the end of the daylight period, when the heat of the sun decreases, the pressure differential between the side tanks **140** reduces and the direction of the flow of the freon through the hollow tube **144** connecting the tanks reverses. The return of the freon to the first tank causes the weight of that tank to increase and the frame of the balance to progressively pivot about the stand in an opposite direction, and the reflector to thereby be progressively returned to its initial sunrise position. A conventional suitable shock absorber **154** connected at one to the frame and at an opposite end to the stand, is provided for inhibiting buffeting of the reflector by wind.

[0136] Typically, the parabolic reflector **136** is dimensioned for providing heating in excess of the amount required. The excess heat may be drawn off and stored in heat banks for use when sunlight is reduced by clouds or during other periods of low sunlight availability such as at sunset. Storing the excess heat in the heat banks for subsequent use may also allow a night cycle of the water condenser apparatus to operate to achieve further condensation of water from ambient night air.

[0137] As heat is generated by the apparatus of FIG. **3** and FIG. **8**, rather than exhausting the warmed air that passes from the condenser **6** into the atmosphere, the warmed air may be used for general heating purposes. For instance, the warmed air may be drawn into ducting by another fan, which directs the warmed air into a room or other space through a vent. Similarly, cooled air passing from the cooling fins **22** of the evaporator **4** may be used for general cooling purposes. For instance, the cooled air may be drawn into ducting by a fan as above. The cooled air can then be directed into further ducting by a sail type valve which exhausts the cooled air onto the condenser and/or other ducting opening into a room or space through a vent which may be the same or different to a vent through which warm air is exhausted. Cooling of the condenser can be compensated by increasing the speed of the fan **98** or by opening the by-pass damper **108** to increase the flow of ambient air flowing into contact with the condenser.

[0138] Moreover, besides collecting water from ambient air for drinking or other purposes, apparatus embodied by the invention may be used as a dehumidifier for dehumidifying silos or other interior spaces where it is desirable to minimise the water content of the air. Similarly, the apparatus may be used for removing water from locations such as from the interior of pipes used for channelling hydrophobic fluids such as oil or petroleum. In such applications, air may be drawn from the silo or pipe(s) prior to being returned to the silo or pipe(s) following the extraction of the water by the apparatus. When a silo (eg wheat silo) is to be dehumidified, the air may first be filtered to remove dust from the air prior to the air contacting the cooling fins of the apparatus.

[0139] Although the present invention has been described hereinbefore with reference to a number of preferred embodiments, the skilled addressee will appreciate that numerous

changes and modifications are possible without departing from the spirit or scope of the invention. The present embodiments described are, therefore, to be considered in all respects as illustrative and not restrictive.

[0140] For instance, rather than a by-pass damper **108**, the apparatus of the invention may be provided with an adjustable valve for modulating the flow rate of the ambient air past the condenser **6**. In addition, a gas and a liquid refrigerant other than ammonia gas and iso-butane may be utilised. For example, other combinations of gases and liquid refrigerants that may be used include ammonia gas and propane, hydrogen chloride gas and propylene, ammonia gas and pentane, hydrogen chloride gas and iso-butane, and methylamine gas and iso-butane.

[0141] Moreover, instead of using solar energy or mains electricity to provide heating, heat from an external waste heat source such as a boiler, engine hot water, or the discharge heat from a refrigeration or air-conditioning condenser may be channelled to components requiring heating such as the separation reservoir **64** by conduit(s), and heating achieved by heat transfer contact with the conduit(s). Similarly, embodiments of the invention may be provided without a fan for drawing the ambient air through the evaporator and/or past the condenser. In this instance, flow of the ambient air through the casing may be achieved by thermal convection currents as a result of temperature differences between the evaporator and external ambient air temperatures.

1. A method for collecting water from ambient air, the method comprising:

- providing at least one condensation surface for contact with the ambient air;
- passing a gas into an enclosed space containing a gaseous mixture of the gas and refrigerant vapour evaporated from a liquid refrigerant such that further refrigerant vapour evaporates into the enclosed space from the liquid refrigerant, and heat is thereby drawn into the refrigerant from the condensation surface cooling the condensation surface to, or below, the dew point of the water in the ambient air; passing the gaseous mixture from the enclosed space;
- contacting the cooled condensation surface with the ambient air to effect condensation of water from the ambient air onto the condensation surface; and
- collecting the condensed water.

2. A method according to claim **1** further comprising condensing the refrigerant vapour in the gaseous mixture passed from the enclosed space back into liquid refrigerant to separate the refrigerant vapour from the gas, returning the gas from the gaseous mixture to the enclosed space for generating more of the gaseous mixture, and recirculating the liquid refrigerant condensed from the gaseous mixture.

3. A method according to claim **2** wherein the gaseous mixture is passed from the enclosed space into contact with a liquid absorbent that absorbs the gas from the gaseous mixture thereby forming a solution, and the gas is separated from the solution for the return of the gas to the enclosed space and recycling of the liquid absorbent for contact with more of the gaseous mixture.

4. A method according to claim **2** wherein the liquid refrigerant condensed from the gaseous mixture is recirculated concurrently with the passage of the gas into the enclosed space and passage of the gaseous mixture from the enclosed space into contact with the liquid absorbent, such that the condensation surface is cooled in a continuous cycle.

5. (canceled)

6. A method according to claim 1 wherein the gas is bubbled through the liquid refrigerant into the enclosed space.

7. A method according to claim 1 further comprising monitoring temperature of ambient air flowing from the condensation surface, and adjusting the flow rate at which the ambient air flows into contact with the condensation surface to a desired flow rate to promote the condensation of the water from the ambient air onto the condensation surface.

8. A method according to claim 2 wherein the ambient air is cooled by contact with the condensation surface and the cooled ambient air is used for cooling the refrigerant vapour in the gaseous mixture passed from the enclosed space, to facilitate condensing the refrigerant vapour back into the liquid refrigerant.

9. A method according to claim 8 wherein the refrigerant vapour is condensed in a condenser and the method further comprises adjusting flow rate of the ambient air flowing from the condensation surface to promote the condensation of the refrigerant vapour.

10. A method according to claim 9 wherein the flow rate of the ambient air flowing from the condensation surface is adjusted relative to a flow rate of the ambient air flowing into contact with the condensation surface.

11. A method according to claim 9 comprising monitoring the flow rate of the ambient air flowing from the condensation surface to evaluate whether it needs to be adjusted to promote the condensation of the refrigerant vapour in the condenser, the monitoring comprising:

- measuring pressure within the condenser;
- measuring temperature within the condenser; and
- assessing the measured pressure and the measured temperature.

12. (canceled)

13. (canceled)

14. An apparatus for collecting water from ambient air, the apparatus comprising:

- at least one condensation surface for contact with the ambient air;

- an evaporator for receiving liquid refrigerant and defining an enclosed space for a gaseous mixture of refrigerant vapour evaporated from the liquid refrigerant and a gas;

- an inlet opening into the evaporator for passage of the gas into the space to cause further evaporation of the liquid refrigerant into the space such that heat is drawn into the liquid refrigerant from the condensation surface, and the condensation surface is thereby cooled to, or below, the dew point of the water in the ambient air to effect condensation of water from the ambient air onto the condensation surface for collection of the water; and

- an outlet for passage of the gaseous mixture from the space.

15. An apparatus according to claim 14 further comprising a separation system for separating the gas in the gaseous mixture from the refrigerant and condensing the refrigerant vapour back into liquid refrigerant, for return of the gas to the enclosed space in the evaporator and recycling of the liquid refrigerant to the evaporator.

16. An apparatus according to claim 15 wherein the separation system comprises a condenser for receiving the gaseous mixture from the evaporator and condensing the refrigerant vapour in the gaseous mixture back into liquid refrigerant, the condenser being adapted to receive liquid absorbent and facilitate contact of the gaseous mixture with

the liquid absorbent for adsorption of the gas into the liquid absorbent to form a solution and thereby separate the gas from the refrigerant vapour.

17. An apparatus according to claim 16 wherein in use, the condenser houses a bath comprising a layer of the liquid refrigerant and a layer of the solution, and the condenser is adapted for receiving the gaseous mixture for contact of the gaseous mixture with the liquid absorbent to form the solution, prior to passage of the solution into the bath.

18. An apparatus according to claim 17 wherein the liquid refrigerant has a lower density than the solution, and the solution separates from the layer of liquid refrigerant into the layer of the solution.

19. An apparatus according to claim 16 further comprising a mixer unit arranged within the condenser for receiving the liquid absorbent, wherein the mixer unit is adapted for creating a flow of the liquid absorbent over a surface of the mixer unit for facilitating the contact of the gas with the liquid absorbent.

20. An apparatus according to claim 19 wherein the mixer unit has an open well for receiving the liquid absorbent and providing the flow of the liquid absorbent down the surface of the mixer unit with overflow of the liquid absorbent from the well.

21. (canceled)

22. (canceled)

23. An apparatus according to claim 16 wherein the separation system further includes a separation reservoir for evaporation of the gas from the liquid absorbent, the separation reservoir comprising:

- a housing;

- an inlet for passage of the liquid absorbent into the housing, the gas evaporating from the liquid absorbent within the housing; and

- an outlet for return of the gas evaporated from the liquid absorbent to the evaporator.

24. An apparatus according to claim 23 wherein the separation reservoir is adapted for being heated to facilitate evaporation of the gas from liquid absorbent.

25. An apparatus according to claim 16 further comprising a pump system for elevating the liquid absorbent to an elevated position for flow of the liquid absorbent to the condenser for contact with further of the gaseous mixture from the evaporator, the pump system comprising:

- a heating reservoir for receiving the liquid absorbent and being heated for causing the liquid absorbent to be forced from the heating reservoir;

- a riser tube for receiving the liquid absorbent from the heating reservoir upon the heating reservoir being heated; and

- a collection reservoir arranged at the elevated position and into which the tube opens for collection of the liquid absorbent, the collection reservoir being adapted for passage of the liquid absorbent from the collection reservoir to the condenser.

26. An apparatus according to claim 25 wherein the collection reservoir has a first outlet for passage of the liquid absorbent from the collection reservoir to the condenser, an interior space for receiving the gas together with absorbent vapour which evaporate from the liquid absorbent with travel along the riser tube, and a further outlet for passage of the gas separated from the liquid absorbent from the collection reservoir to the evaporator.

27. An apparatus according to claim **14** further comprising a control system for controlling flow rate of the ambient air into contact with the condensation surface, the control system comprising: a temperature sensor for determining temperature of the ambient air flowing from the condensation surface, the control system being adapted to monitor the temperature determined by the temperature sensor and adjust flow rate of the ambient air flowing into contact with the condensation surface to promote condensation of the water from the ambient air onto the condensation surface.

28. An apparatus according to claim **27** adapted to direct the ambient air flowing from the condensation surface to the condenser, and wherein the control system further includes an adjustable air intake operable to adjust flow rate of the ambient air flowing from the condensation surface to the condenser relative to a flow rate of the ambient air flowing into contact with the condensation surface, to thereby alter temperature and pressure within the condenser to promote the condensation of the refrigerant vapour.

29. An apparatus according to claim **28** wherein the control system further includes a temperature sensor for measuring temperature in the condenser, and a pressure sensor for measuring pressure within the condenser, and the control system is further adapted to assess the temperature measured by the temperature sensor and the pressure measured by the pressure sensor, and operate the adjustable air intake to alter the flow rate of the ambient air flowing to the condenser.

30. (canceled)

31. (canceled)

32. An evaporator for effecting condensation of water from ambient air, the evaporator comprising:

at least one condensation surface for contact with the ambient air; a housing for receiving liquid refrigerant and having an enclosed interior space for a gaseous mixture of refrigerant vapour evaporated from the liquid refrigerant and a gas;

an inlet for passage of the gas into the space to cause further evaporation of the liquid refrigerant into the enclosed space such that heat is drawn into the liquid refrigerant from the condensation surface and the condensation surface is thereby cooled to, or below, the dew point of the water in the ambient air to effect condensation of the water from the ambient air onto the condensation surface for collection of the water;

and an outlet for passage of the gaseous mixture from the enclosed space.

33. An evaporator according to claim **32** wherein the, or each, condensation surface is a surface of cooling fin respectively, and the housing of the evaporator comprises:

an upper region for receiving the gaseous mixture of the gas and the refrigerant vapour;

a lower region for being at least partly filled with the liquid refrigerant and being spaced from the upper region; and at least one conduit that opens at one end into the upper region of the housing and at an opposite end into the lower region; and

wherein the, or each, cooling fin is arranged between the upper region and the lower region for contact with the ambient air.

34. (canceled)

35. A method for separating a gas from a refrigerant vapour in a gaseous mixture, the method comprising:

providing a condenser adapted for condensing the refrigerant vapour into liquid refrigerant, the condenser hous-

ing a mixer unit for receiving a liquid absorbent for absorbing the gas and which is adapted for facilitating contact of the liquid absorbent with the gaseous mixture; passing the gaseous mixture into the condenser to effect the condensing of the refrigerant vapour; and passing the liquid absorbent to the mixer unit whereby the liquid absorbent contacts the gaseous mixture such that the gas is absorbed into the liquid absorbent forming a solution of the liquid absorbent and the gas.

36. (canceled)

37. (canceled)

38. A condenser for separating a gas from a refrigerant vapour in a gaseous mixture, the condenser comprising:

a housing for receiving the gaseous mixture and condensing the refrigerant vapour into liquid refrigerant; and

a mixer unit arranged within the housing for receiving a liquid absorbent for absorbing the gas to form a solution of the gas and the liquid absorbent, the mixer unit being adapted for facilitating contact of the gaseous mixture with the liquid absorbent.

39. A mixer unit for mixing a gas with a liquid absorbent for absorbing the gas from a gaseous mixture of the gas and a refrigerant vapour to separate the gas and the refrigerant vapour, the mixer unit comprising:

a mixer body for receiving the liquid absorbent and facilitating contact of gaseous mixture with the liquid absorbent for absorption of the gas, the mixer body being adapted for facilitating contact of the gaseous mixture with the liquid absorbent.

40. A method for providing heating from an apparatus during operation of the apparatus, the method comprising:

passing a gas into an enclosed space containing a gaseous mixture of the gas and refrigerant vapour evaporated from a liquid refrigerant, such that further passing the gaseous mixture from the enclosed space to a condenser for condensing the refrigerant vapour in the gaseous mixture back into liquid refrigerant;

passing the gaseous mixture from the enclosed space to a condenser for condensing the refrigerant vapour in the gaseous mixture back into liquid refrigerant;

returning the gas from the gaseous mixture to the enclosed space;

recirculating the liquid refrigerant condensed from the gaseous mixture for evaporation into the enclosed space; and

drawing off heat from the condenser to provide the heat.

41. (canceled)

42. A method for providing cooling from an apparatus during operation of the apparatus, the method comprising:

providing at least one cooling surface for contact with ambient air;

passing a gas into an enclosed space containing a gaseous mixture of the gas and refrigerant vapour evaporated from a liquid refrigerant, such that further refrigerant vapour evaporates into the enclosed space from the liquid refrigerant, and heat is thereby drawn into the liquid refrigerant from the cooling surface cooling the cooling surface;

passing the gaseous mixture from the enclosed space; contacting the cooled cooling surface with the ambient air to effect cooling of the ambient air;

and using the cooled ambient air to provide the cooling.

43. (canceled)

44. (canceled)

45. A solar heating device for providing solar heating, the device comprising:

at least one pair of spaced apart reservoirs for being differentially heated by solar heat from the sun and being pivotable about a pivot axis, one or both of the reservoirs being partly filled with a refrigerant;

at least one conduit for passage of the refrigerant from the one reservoir to the other reservoir upon the one reservoir being heated by the solar heat relative to the other reservoir, and return of the refrigerant to the one reservoir upon the one reservoir cooling relative to the other reservoir, the pair of reservoirs being pivoted about the pivot axis in one direction with passage of the refrigerant

from the one reservoir to the other reservoir and in an opposite direction with the return of the refrigerant to the one reservoir; and

a reflector for reflecting the solar heat onto an object to be heated, the reflector being arranged to rotate about an axis of rotation in a first direction for substantially maintaining the reflection of the solar heat on the object with the pivoting of the pair of reservoirs about the pivot axis in the one direction, and being rotatable about the axis of rotation in an opposite direction as the pair of reservoirs are pivoted in the opposite direction about the pivot axis.

* * * * *