



US 20080106893A1

(19) **United States**

(12) **Patent Application Publication**
Johnson et al.

(10) **Pub. No.: US 2008/0106893 A1**

(43) **Pub. Date: May 8, 2008**

(54) **LAMP AND BULB FOR ILLUMINATION AND AMBIANCE LIGHTING**

(22) Filed: **Jun. 18, 2007**

Related U.S. Application Data

(63) Continuation of application No. 10/561,822, filed on Apr. 25, 2006.

Publication Classification

(51) **Int. Cl.**
F21S 10/00 (2006.01)
H05B 37/02 (2006.01)
G05B 15/00 (2006.01)

(52) **U.S. Cl.** **362/228; 315/294; 315/297; 700/83; 700/87**

(75) Inventors: **H. Fisk Johnson**, Racine, WI (US);
Jose Porchia, Greenfield, WI (US);
Barry T. Calpino, Portage, MI (US);
Jeffrey J. Wolf, Racine, WI (US)

Correspondence Address:
S.C. JOHNSON & SON, INC.
1525 HOWE STREET
RACINE, WI 53403-2236

(57) **ABSTRACT**

An Edison-style light bulb (40) which supports a plurality of light emitting diodes (LEDs) (50) and an illumination source (54). First and second electrical circuits (56) and (58) are mounted in the bulb to supply electrical power to the illumination source and to the LEDs. A switch circuit (60) is connected to control the supply of electrical power to the first and second electrical circuits (56) and (58) to adjust and coordinate the light output from the LEDs (50) and from the illumination source (54).

(73) Assignee: **S. C. JOHNSON & SON, INC.**,
Racine, WI (US)

(21) Appl. No.: **11/764,526**

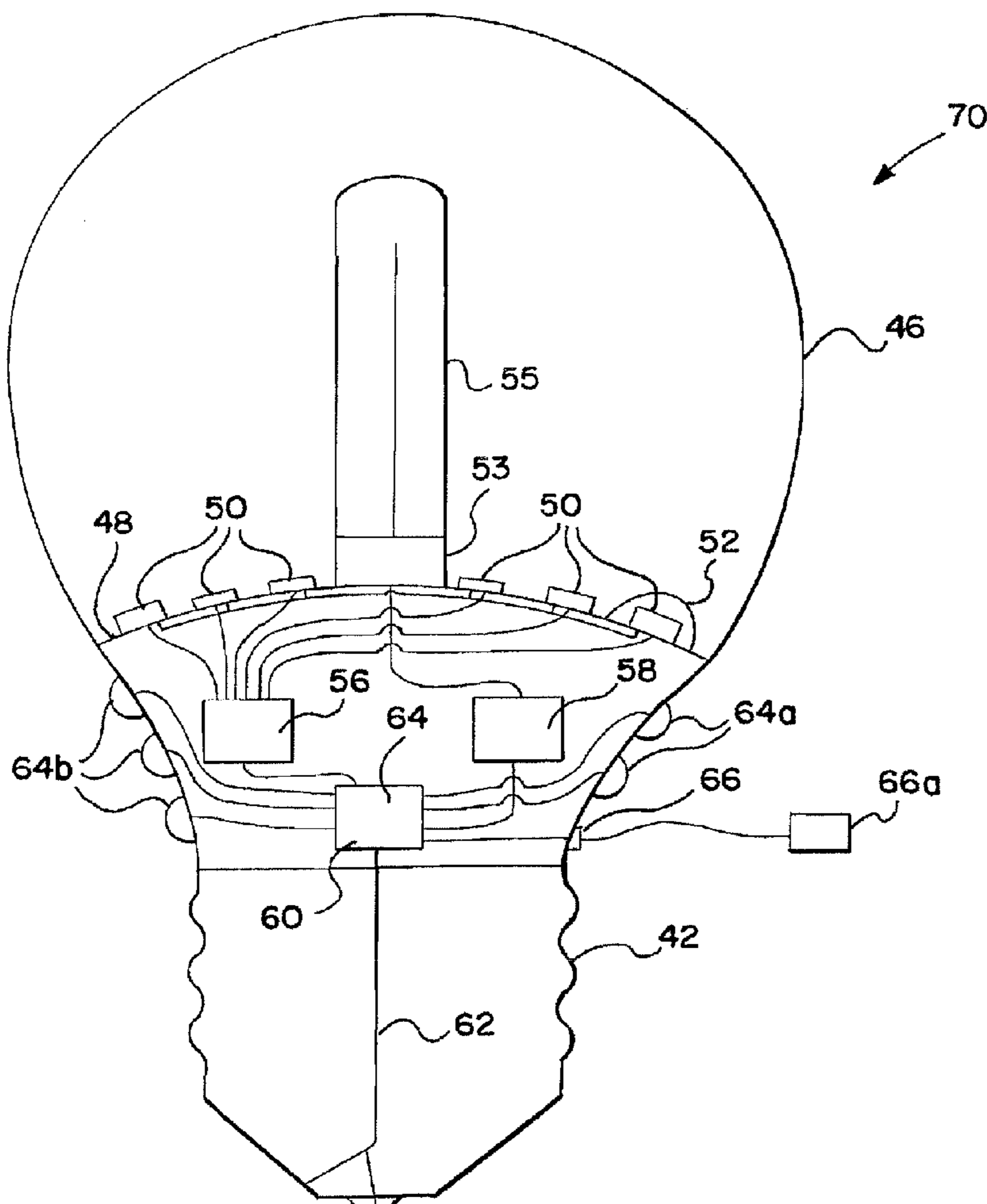

FIG. 1

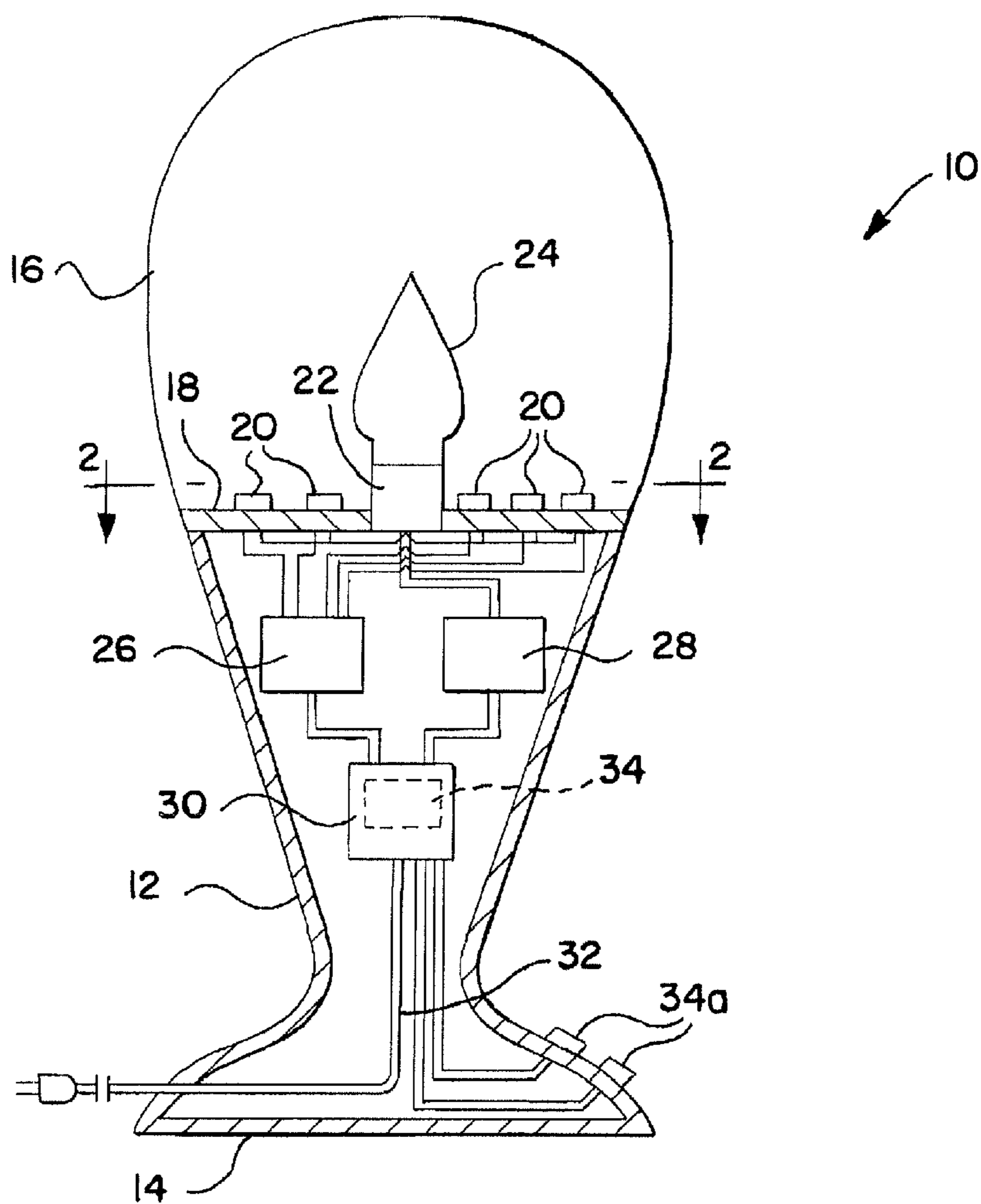

FIG. 2

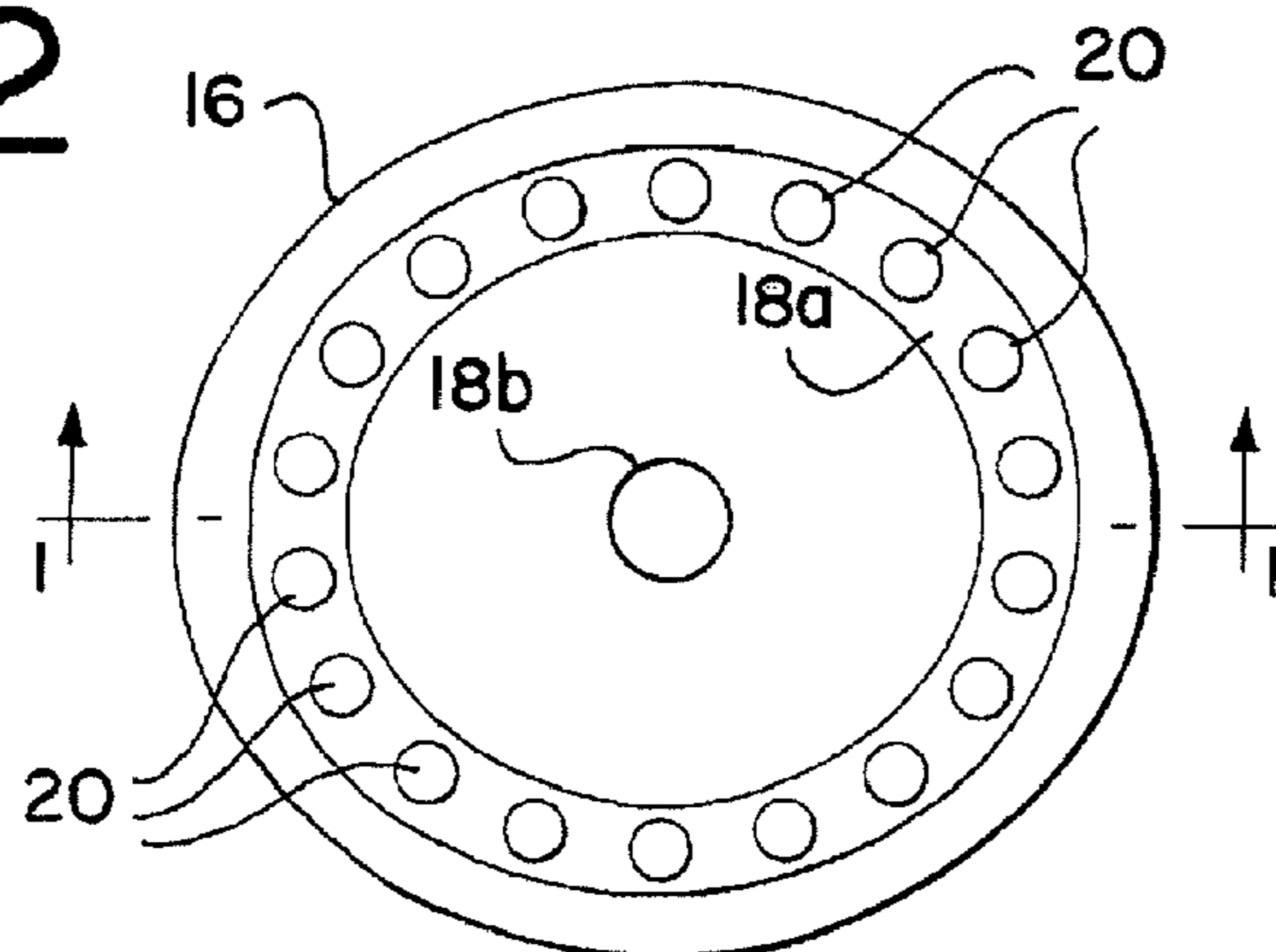

FIG. 3

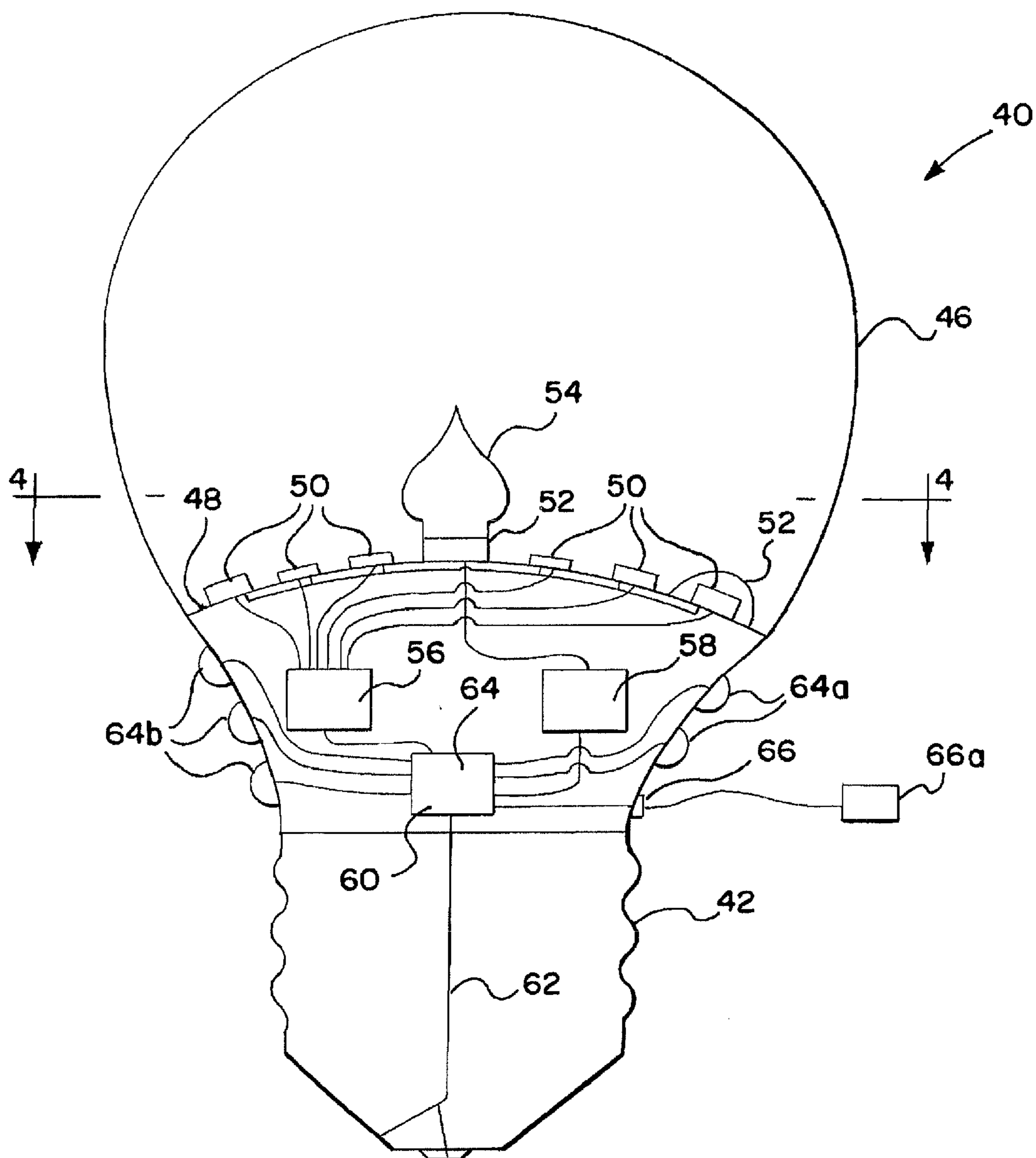

FIG. 4

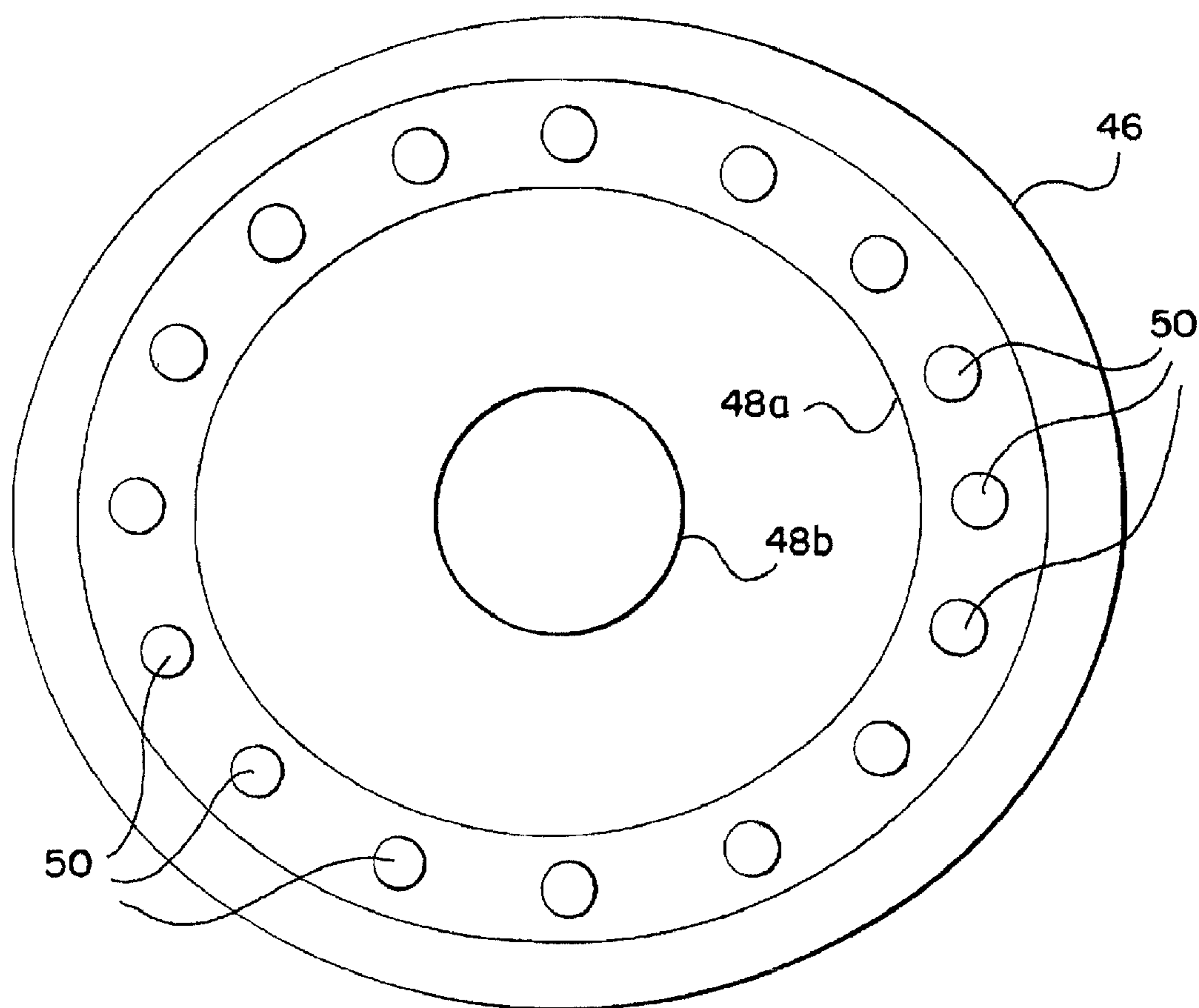

FIG. 5

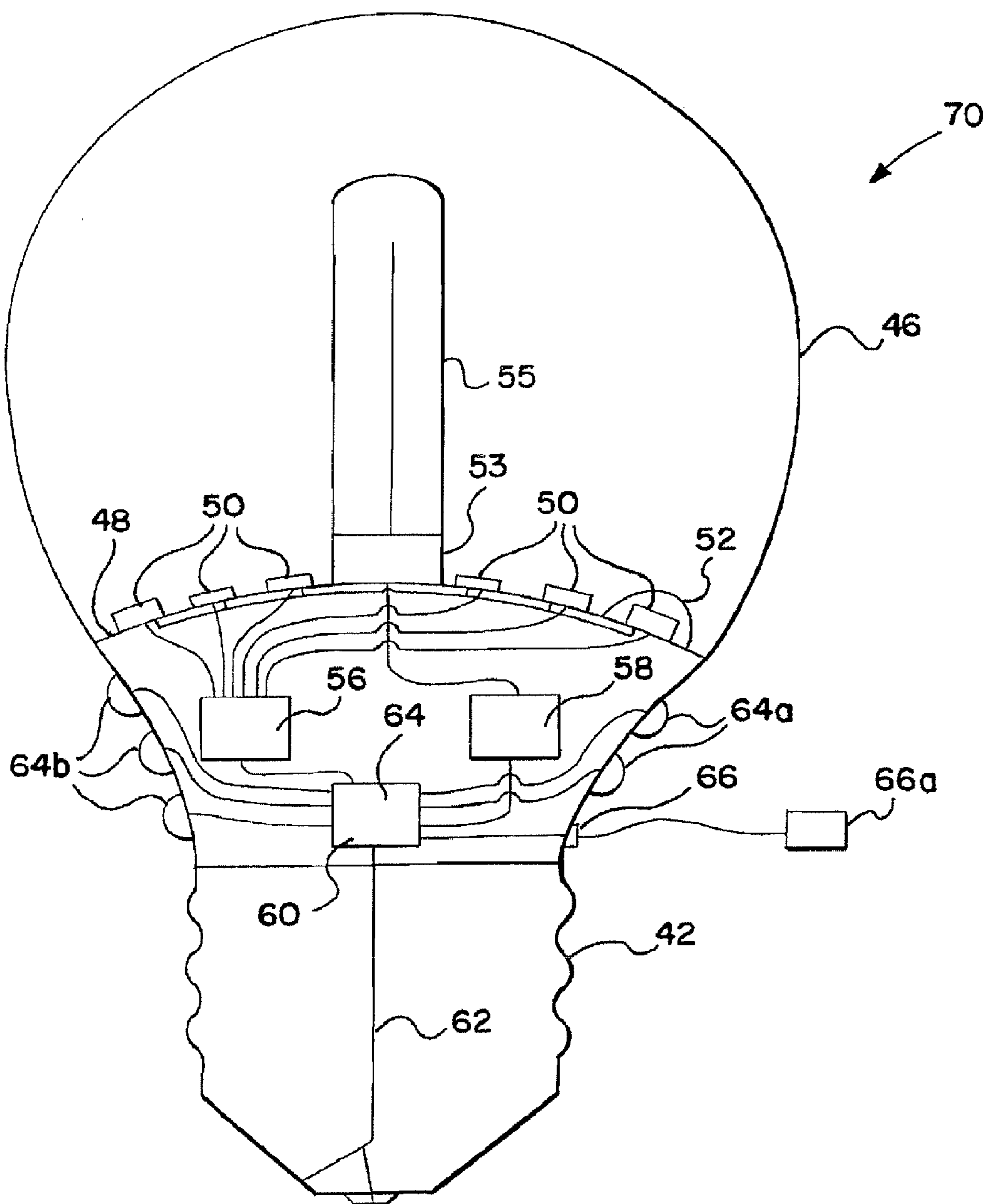

FIG. 6A

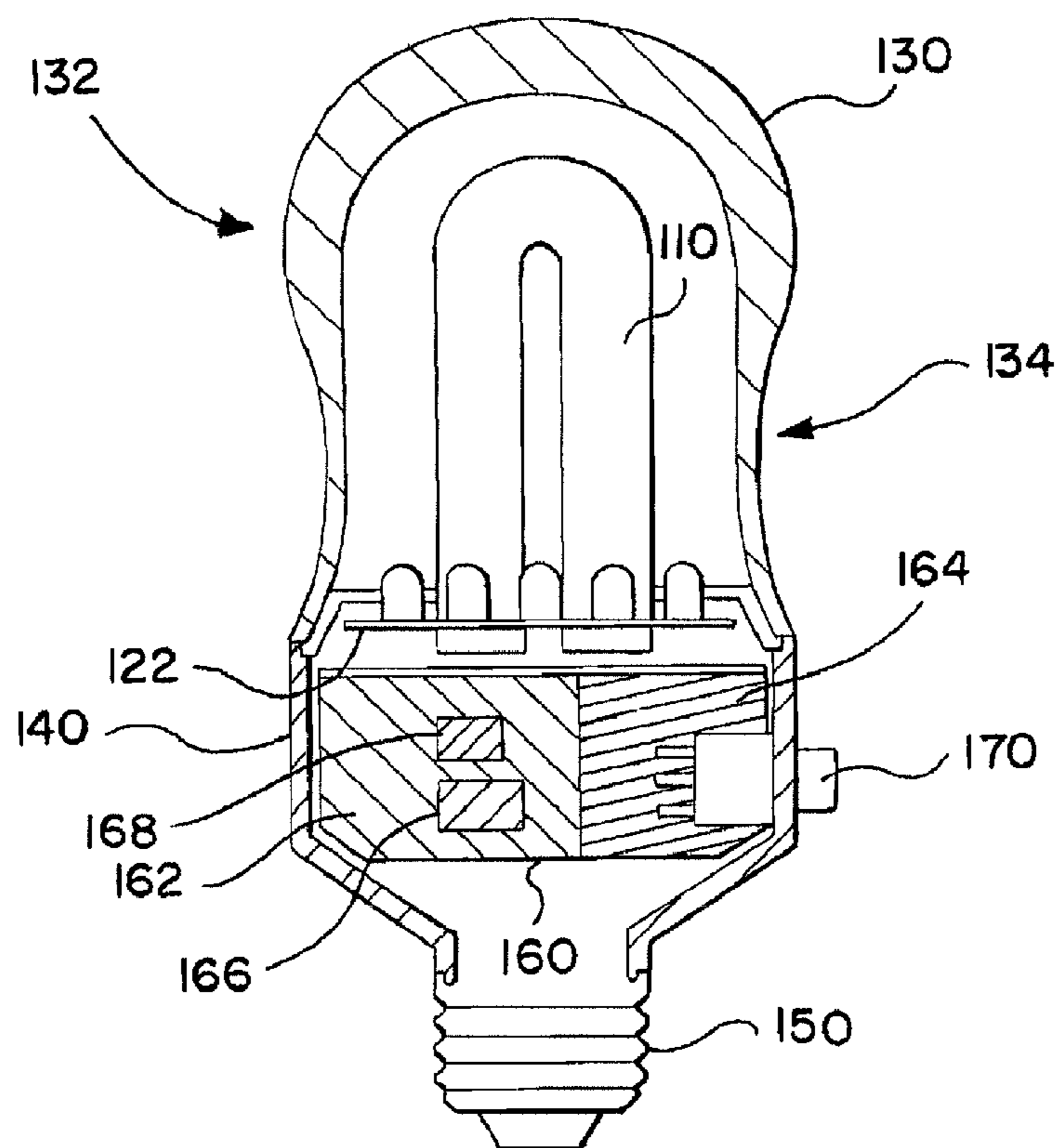

FIG. 6B

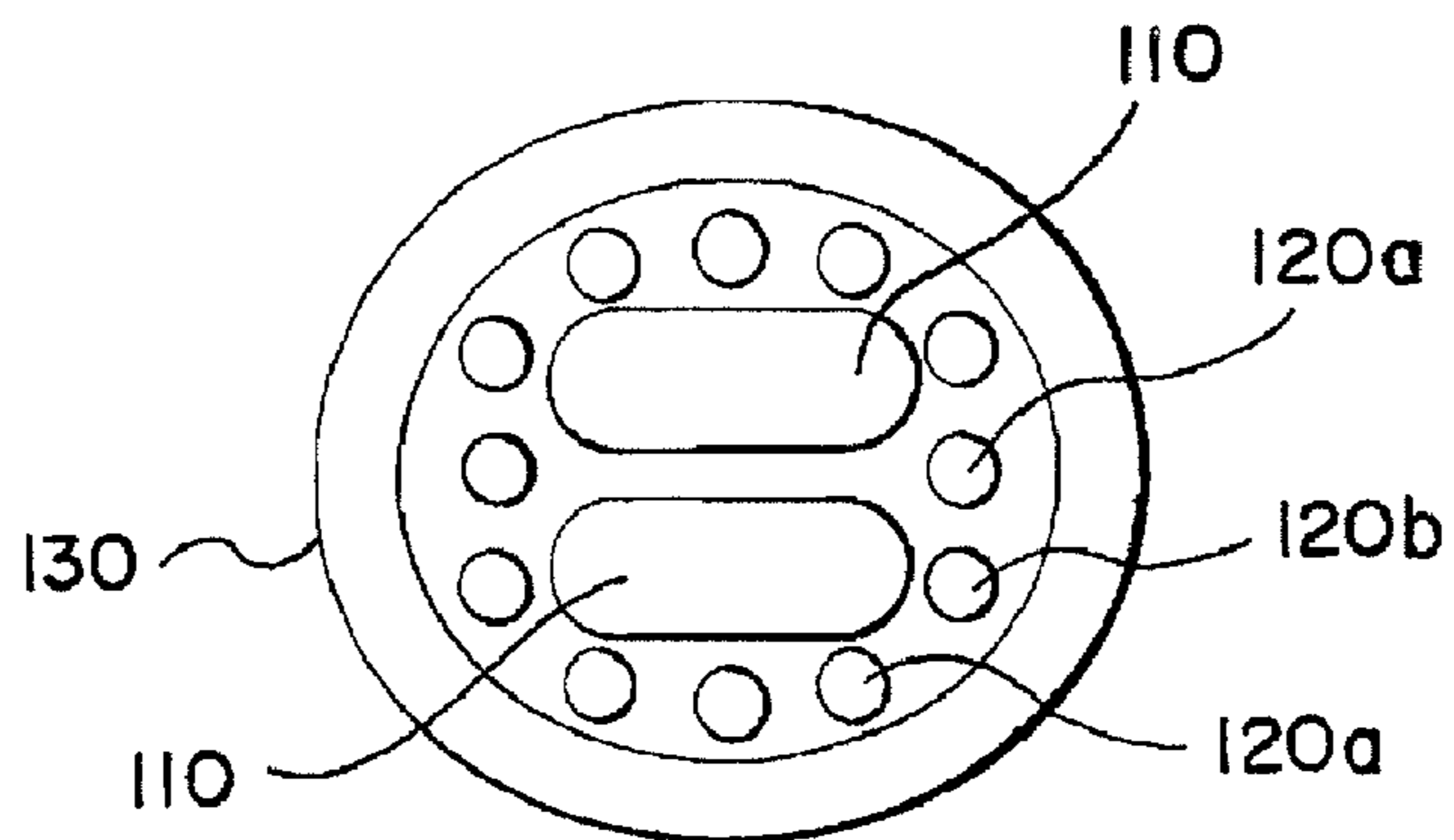

FIG. 7

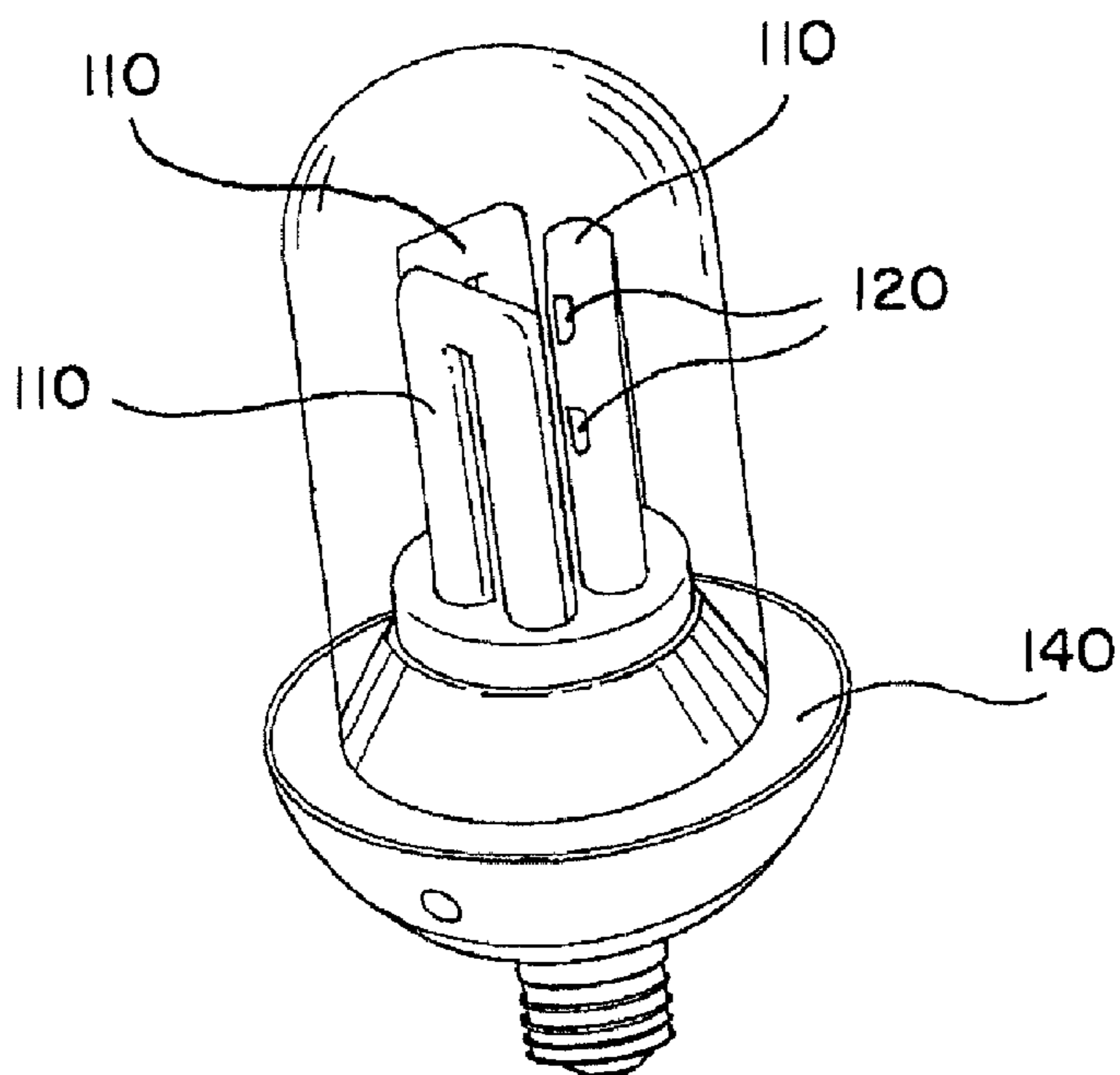

FIG. 8

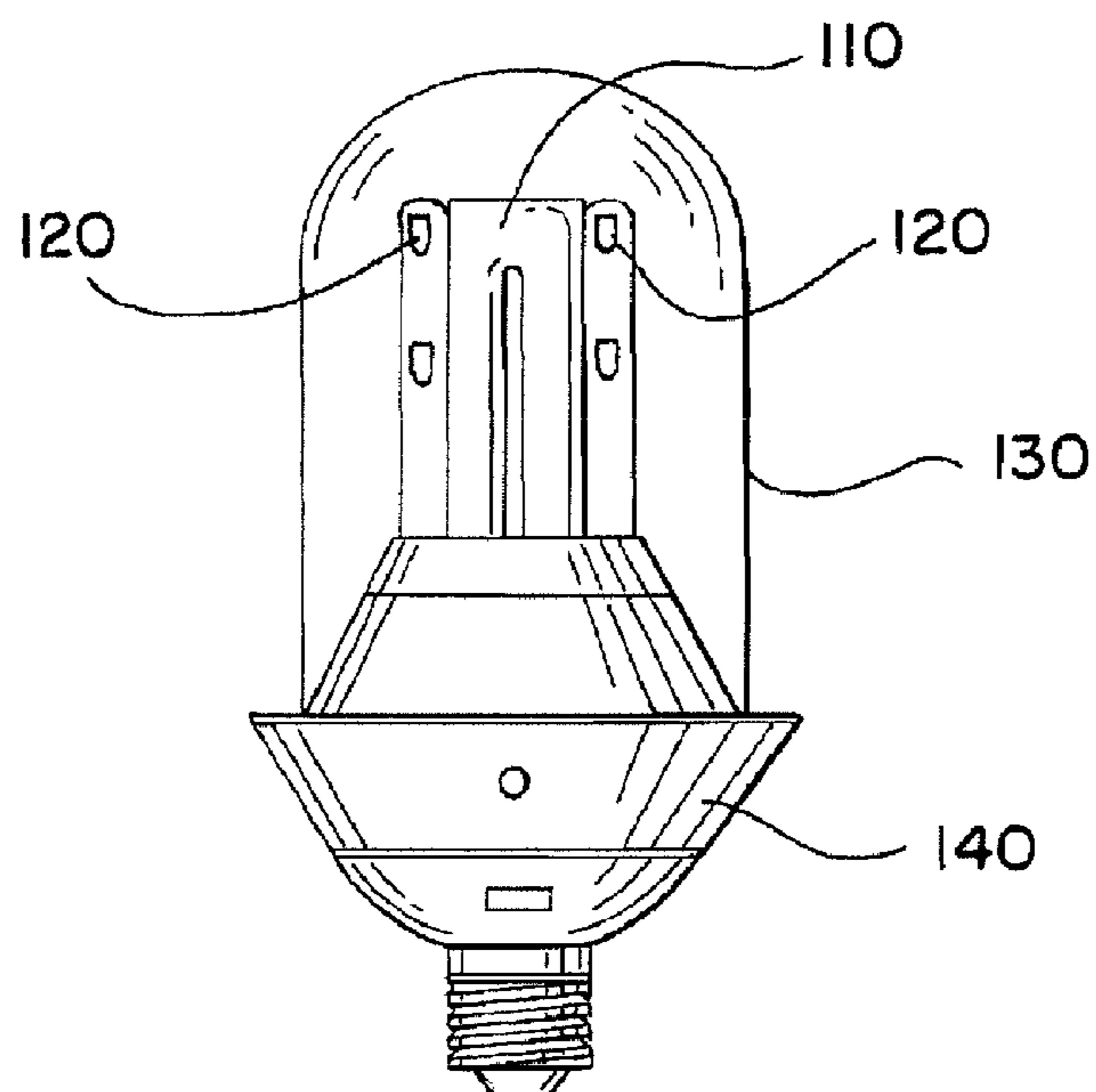
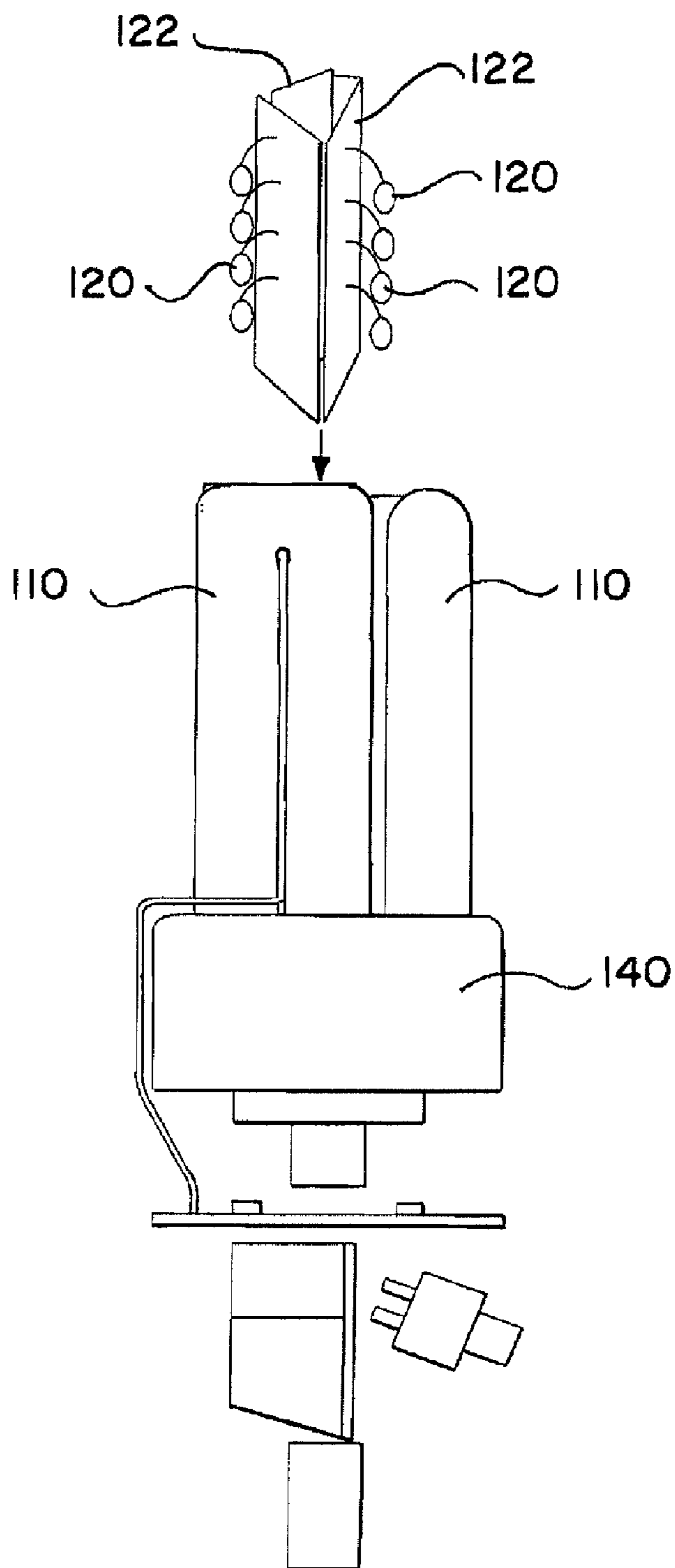

FIG. 9



LAMP AND BULB FOR ILLUMINATION AND AMBIANCE LIGHTING

BACKGROUND OF THE INVENTION

[0001] 1. Field of the Invention

[0002] Our invention relates to novel lighting devices which provide light for illumination as well as ambient light.

[0003] 2. Description of Related Art

[0004] Electric lamps, and the light bulbs used therein, which provide illumination are well known and are widely used. These lamps and bulbs fall into two general categories, namely, incandescent and fluorescent. More recent developments in lighting have led to advancement in light emitting diodes (LEDs). An LED is a semiconductor device that emits visible light when an electrical current passes through it. The light from an LED is basically monochromatic and the color of the light is determined by the particular material used in the semiconductor (although current applied to the LED can be used to vary the perceived color). LEDs have the advantage of low power requirements, high efficiency and long life. The outputs of several different color LEDs can be mixed so as to produce additional colors, including white light, and different brightness. LEDs can also be used to provide background lighting to achieve desired ambient effects. However, they have limited brightness and therefore they are generally not suitable for illumination purposes. Instead, LEDs have been generally used for such applications as indicator lights, panel backlighting and fiber optic data transmission.

[0005] U.S. Pat. No. 6,149,283 discloses an LED lamp/bulb having a multicolor adjustor. This device comprises a base in which several LEDs capable of producing different colored light are mounted. Adjustable switches are provided for the different color LEDs so that the colors can be mixed in any desired ratio to produce desired lighting effects such as varying colors, including white light, and varying brightness. This patent acknowledges that the lumen output of LEDs is not as high as an incandescent source of the identical wattage.

[0006] U.S. Pat. No. 5,924,784 discloses providing ambient light (simulating a candle flame) from both a free-standing lamp and an Edison-style light bulb (i.e., a screw-in bulb that mates with a conventional light bulb socket) using LEDs. The flame simulation is provided through both color combinations emitted and flicker effects. The patent states that it is directed to bulbs and lamps used for achieving soothing effects in memorials and the like.

[0007] U.S. Pat. Nos. 6,016,038, 6,150,774, 6,166,496, 6,211,626, 6,292,901 and 6,340,868 disclose various techniques and electrical circuits for controlling the light output of several LEDs according to predetermined programs.

SUMMARY OF THE INVENTION

[0008] This invention makes possible the provision of desired ambient or background light together with illumination light in a single lamp fixture or light bulb.

[0009] According to one embodiment of our invention, there is provided a novel electrical lamp which includes an illumination socket for mounting an illumination bulb which emits illumination light, a plurality of light emitting diodes which emit light of different colors, a base in which the illumination socket and the light emitting diodes are positioned in proximity to each other, a first electrical circuit connected to supply electrical power to the illumination socket, a second electrical circuit connected to supply elec-

trical power to the light emitting diodes, and switching means connected to selectively switch the application of electrical power between the first electrical circuit and the second electrical circuit. The illumination socket is a socket for mounting an illumination bulb selected from the group consisting essentially of incandescent bulbs, fluorescent bulbs and halogen bulbs.

[0010] In another embodiment, our invention is directed to a light bulb. The bulb includes an illumination source which emits illumination light, a plurality of light emitting diodes which emit light of different colors, a base on which the illumination source and plurality of light emitting diodes are mounted in proximity to each other, a first electrical circuit connected to supply electrical power to the socket, a second electrical circuit connected to supply electrical power to the light emitting diodes, and a switch connected to selectively switch the application of electrical power between the first electrical circuit and second electrical circuit. Also, the illumination source is selected from the group consisting essentially of incandescent bulbs, fluorescent bulbs and halogen bulbs. (When we talk about such conventional "bulbs" used in connection with the lamps and bulbs according to our invention, the conventional "bulbs" may include replaceable screw-in bulbs and the like, as well as more permanent light emitting devices mounted in bulbs or lamps of our invention.)

[0011] In another embodiment, our invention is directed to a light bulb having a base configured to mate with a light bulb socket. At least one compact fluorescent bulb is mounted on the base. Also, a plurality of light emitting diodes are mounted on the base, which LEDs emit light of different colors. A control circuit supplies power from the light socket, when the base is mounted therein, to the at least one fluorescent bulb and the plurality of light emitting diodes. A translucent housing is mounted on the base and contains the at least one fluorescent bulb and the plurality of light emitting diodes.

[0012] In yet another embodiment, our invention is directed to a light bulb having a base configured to mate with a light bulb socket. A light emitting device is mounted on and receives power from the base. The light emitting device is selected from the group consisting essentially of halogen, incandescent, fluorescent, and low vapor mercury light emitting devices. A plurality of light emitting diodes are also mounted on and receive power from the base. The plurality of light emitting diodes emit light of different colors. A programmable processor controls the activation, color and intensity of the light emitted from the plurality of the light emitting diodes. Again, a translucent housing is mounted on the base and contains the light emitting device and the plurality of light emitting diodes.

[0013] In another embodiment, our invention is directed to a light bulb having a base configured to mate with a light bulb socket. A light emitting device is mounted on and receives power from the base. The light emitting device is selected from the group consisting essentially of halogen, incandescent, fluorescent, and low vapor mercury light emitting devices. A plurality of light emitting diodes are mounted on and receive power from the base. The plurality of light emitting diodes emit light of different colors. A user interface controls the activation, color and intensity of the light emitted from the plurality of the light emitting diodes. Further, a

translucent housing is mounted on the base and contains the light emitting device and the plurality of light emitting diodes.

BRIEF DESCRIPTION OF THE DRAWINGS

[0014] FIG. 1 is a diagrammatic elevational sectional view of a lamp according to one embodiment of our invention;

[0015] FIG. 2 is a sectional view along line 2-2 of FIG. 1;

[0016] FIG. 3 is a diagrammatic elevational sectional view of an Edison-style light bulb according to another embodiment of our invention;

[0017] FIG. 4 is a sectional view along line 4-4 of FIG. 3; and

[0018] FIG. 5 is a diagrammatic elevational sectional view of an Edison-style light bulb according to another embodiment of our invention.

[0019] FIGS. 6A and 6B are a cross-sectional and top view, respectively, of another bulb according to an embodiment of our invention.

[0020] FIG. 7 is a perspective view of another bulb according to another embodiment of our invention.

[0021] FIG. 8 is a side view of the bulb shown in FIG. 7.

[0022] FIG. 9 is a partially exploded view of the bulb shown in FIGS. 8 and 9.

DETAILED DESCRIPTION OF THE PREFERRED EMBODIMENT

[0023] As shown in FIG. 1, a lamp 10 according to one embodiment of our invention includes a base 12 having a flat bottom 14, which may rest on a horizontal surface, such as a table top or a desk, and a translucent shade 16, which extends up from the base and which permits light generated therein to be emitted out from the lamp. The base 12 includes a bulb support 18 near its upper end. The bulb support 18 serves as a mounting for a plurality of light emitting diodes (LEDs) 20 as well as a socket 22 for an illumination bulb 24, which may be, for example, a conventional, screw-in incandescent bulb. As can be seen, the LEDs 20 and the illumination bulb 24 are positioned so that light generated from these devices can be emitted through the shade 16.

[0024] The bulb support 18, as shown in FIG. 2, has an outer portion 18a in the form of a ring; and the LEDs 20 are distributed around this outer portion. The bulb support 18 also includes a center portion 18b which supports the illumination bulb socket 22.

[0025] A first electrical circuit 26 is provided in the base 12 and is connected to supply electrical power to each of the LEDs 20. A second electrical circuit 28, also provided in the base 12, is connected to supply electrical power to the illumination bulb socket 22. A switch circuit 30 is also provided in the base 12 and is connected to supply electrical power to the first and second electrical circuits 26 and 28. The switch circuit 30 is connected to a power line 32, which may receive electrical power from a battery (not shown) contained within the lamp base 12, or from an outside source such as a household electrical output.

[0026] The switch circuit 30 includes a program control unit 34, which is configured to switch electrical power to the first and second electrical circuits 26 and 28 as desired, i.e., either to both simultaneously or to each alternately, depending on the type of light to be produced by the lamp 10. The program control unit includes control switch actuators 34, which are located on the base 12 for manual adjustment of the

output intensity or brightness of the LEDs 20 and of the illumination bulb 24. The program control unit 34 may also incorporate an internal program and associated circuits which provide adjustment of the LEDs 20 and the illumination bulb 24 in a predetermined manner. This can provide selectable light shows among which a user may choose. In addition, sensors (not shown) may be provided to sense other conditions in the area of the lamp 10, e.g., temperature, scent, sound, motion, etc., and to adjust the program in the program control unit 34 so as to coordinate the light outputs from the lamp 10 with such sensed conditions.

[0027] As shown in FIG. 3, an Edison-style light bulb 40 according to another embodiment of the invention includes a threaded, Edison-style base 42 for use with conventional light bulb sockets. (Of course, the bulb may be configured to mount in other conventional sockets for mounting light bulbs, such as fluorescent and halogen.) A translucent housing 46 extends up from base 42. The translucent housing 46 allows light generated therein to be emitted from the bulb.

[0028] A lighting support 48 is positioned within housing 46, and serves as a mounting for a plurality of LEDs 50 and an illumination source mounting socket 52. Socket 52 mounts, and provides power to, an incandescent illumination source 54. Light generated by the LEDs 50 and illumination source 54 is emitted through housing 46. Housing 46 may be releasably secured to base 42, to allow for replacement of illumination source 54.

[0029] The light source support 48, as shown in FIG. 4, has an outer portion 48a in the form of a ring. The LEDs 50 are distributed around this outer portion. The light source support 48 also includes a center portion 48b which supports socket 52, or the illumination source 54, when the illumination source 54 is fixedly mounted on support 48 without a socket. A socket is preferably used in order to allow for replacement of burned out illumination sources, since the LEDs 56 are expected to outlast any conventional illumination source.

[0030] A first electrical circuit 56 is connected to supply electrical power to each of the LEDs 50. A second electrical circuit 58 is connected to supply electrical power to illumination source 54. Also provided is a switch circuit 60, which is connected to supply electrical power to the first and second electrical circuits 56 and 58. The switch circuit 60 is connected to power supply line 62, which receives electrical power from an Edison-style light bulb socket when mounted thereon. The switch circuit 60 includes a program control unit 64, which is configured to switch electrical power to the first and second electrical circuits 56 and 58 as desired, depending on the type of light to be produced. The program control unit 64 includes control switch actuators 64a, which are located on the outside of housing 46. The control switch actuators 64a provide for switching between different modes of light presentation, i.e., activating either one of first and second electrical circuits 56 and 58, or activating both simultaneously. The program control unit 64 also includes switch actuators 64b, also located on the outside housing 46, for manual adjustment of, for example, the output intensity or brightness of the LEDs 50 and illumination source 54, pre-programmed light shows using the LEDs 50, the color of the light provided by the LEDs 50, etc. The control switch actuators 64b may operate by controlling internal programs and associated circuits of program control unit 64. In addition, any one of a number of control mechanisms may be used in keeping with the present invention including microprocessors, mechanical activity devices, software driven control, and the like. Also,

we have referred to the depicted LEDs **50** as separate light emitting diodes; however, the depicted LEDs **50** may also be individual groups of light emitting diodes. For instance, a single LED group **50** may include three individual light emitting diodes specific to colors red, green, and blue, respectively. With such a configuration, the program control unit **64** may individually set the relative intensity of each of the light emitting diodes of each group so as to control the color emitted from those groups, i.e., the color emitted from a depicted LED group **50** may be varied based on the combination of colors from the individual light emitting diodes of the group. A user may perceive the combined color by way of positioning the individual diodes of an LED group **50** so closely together as to produce an overall color effect, or alternatively, a translucent shade (e.g., a diffuser) **52** may be provided to cover each LED **50**, thus providing for a single perceived color to be emitted from each shade **52** as if it were a single pixel.

[0031] The program control unit **64** further includes a sensor input **66** for receiving signals from a sensor **66a**. Sensor **66a** may be provided on the light bulb **40** or at a remote location. When positioned at a remote location, signals from sensor **66a** may be transmitted to the sensor input **66** by way of a direct connection or a wireless connection (i.e., radio signal, infrared signal, etc.).

[0032] Sensor **66a** may sense such stimuli as temperature, sound, motion, etc. The program control unit **64** may adjust a program for operation of LEDs **50** and illumination source **54** based on the sensed conditions.

[0033] In addition, control signals may also be provided by direct connection or a wireless connection by a user, rather than a sensor. For instance, as regards direct connection, a user may simply vary the application of the power source by toggling a power switch which controls the power supply to the device with which bulb **40** is mated. In this case, the sensor input **66** may sense the power supply and change the control of the device based on the timing of the activation and deactivation of the power supply. Alternatively, a remote control may be provided so that a user may send control signals (e.g., radio signals, infrared signals, etc.) to the sensor input **66**. These control options may be provided in addition to or in lieu of switches **64a** and **64b**.

[0034] FIG. 5 shows an Edison-style light bulb **70** according to yet another embodiment of our invention. In this embodiment, a fluorescent illumination source **55** is mounted on a socket **53**. Of course, the illumination may be provided in a conventional light bulb socket, which allows for replacement of the bulb, or alternatively may be a lighting device permanently affixed to a device according to our invention. The remainder of the features of light bulb **70** are similar to the like-numbered features discussed above with respect to light bulb **40**, shown in FIG. 3.

[0035] FIGS. 6A and 6B show another embodiment of our invention embodied in bulb **100**. Bulb **100** is similar to previous embodiments in that it includes a base **140** having a screw-in connector **150** adapted to mate with a conventional incandescent light bulb socket in a lamp or the like. Of course, connector **150** may be of any one of a number of configurations that mate with other conventional light sockets (e.g., fluorescent, halogen, etc.).

[0036] Bulb **100** also includes a translucent housing **130**. Housing **130** encloses bulbs **110**. While other light emitting devices may be provided to provide the bright, white light associated with conventional light bulbs, it is preferred that

compact fluorescent bulbs be used. (Of course, bulbs **10** may be replaceable light bulbs, or more permanently affixed light emitting devices.) In this embodiment, we will discuss a plurality of compact fluorescent bulbs which are provided to increase the power of the bulb **100** and the overall surface area within housing **130** emitting white light (or the like).

[0037] As is shown in FIG. 6A, compact fluorescent bulbs **110** are each formed in an upside down, substantially U-shaped configuration. (Of course, other arrangements are possible while keeping with the scope of our invention). In particular, a compact fluorescent bulb **110** may have a first electrode at one end from which it extends up in a direction away from base **140**, until it bends back on itself near the top of housing **130**, so as to extend back toward base **140** to a second electrode at the other end. FIGS. 6A and 6B show two such bulbs **110**.

[0038] Alternatively, compact fluorescent bulbs **110** can be formed of a single bulb that has a plurality of separate lengths, each of which extends up from the base **140** and then bends back on itself to extend back to base **140**, with the lengths being interconnected so as to have only two electrodes, each at opposite ends of the total length. More specifically, while FIGS. 6A and 6B appear to show two separate U-shaped bulbs, the term plurality of compact fluorescent bulbs used within this specification can refer to a single compact fluorescent bulb that is bent multiple times to have distinct lengths, as shown in FIGS. 6A and 6B.

[0039] In a most preferred embodiment, the total length of the multiple compact fluorescent bulbs **110** is in the range of about 2 to about 21 inches, whether the compact fluorescent bulbs are actually distinct bulbs, or a single bulb having a plurality of distinct lengths. Preferably, this could include about 1 inch lengths, with one bend, to about 3.5 inch lengths, with 1 to 3 bends. This provides a high surface area of light emission to provide ample light to illuminate a room or the like. Also, it should be noted that any number of shapes and configurations may be used to form compact fluorescent bulbs **110** (or other bulbs), other than the U-shaped configuration shown in the figures. For instance, spiral or helical shapes may be used.

[0040] Bulb **100** also includes a plurality of LEDs **120**. Similar to embodiments discussed above, LEDs **120** are arranged on an LED board **122** so as to encircle the compact fluorescent bulbs **110**. In addition, LEDs **120** include a number of different color LEDs. More specifically, as shown in this embodiment, the LEDs of different colors are arranged such that adjacent individual LEDs **120a** and LEDs **120b** are LEDs of different colors. With such a configuration, the different colored LEDs may be evenly spaced around the inside of housing **130** to provide a suitable light display when perceived from any side of bulb **100**. As discussed above with respect to other embodiments, the LEDs may also be configured differently such that a grouping of different colored LEDs may be positioned close to each other (and optionally, covered by a light diffuser so that the group acts as a single pixel) to give increased control over the perception by a user of the colors to be emitted from housing **130**. In such embodiments, LEDs **120** may be controlled to provide a more fluid, continuous change between different emitted colors (e.g., color wash). In the embodiment shown in FIGS. 6A and 6B, the separation of differently colored LEDs **120a** and **120b** provides a more distinct and delineated change of colors, as perceived by user, in comparison with an embodiment in which a group of differently colored LEDs **120** are positioned

close to each other so as to be perceived by user as a single pixel. Alternatively, the arrangement may include close groupings of LEDs, with individual LEDs or the grouping still being separately discernable.

[0041] LEDs 120, compact fluorescent bulbs 110 and LED board 122 are mounted on base 140, directly or indirectly. Base 140 includes a control circuit board 160 which includes LED power supply 164 and compact fluorescent bulb power supply 162. By providing power (and control) for these features on one board, a more compact bulb 100 is achieved. Board 160 may include conventional switches and potentiometers for controlling the functions of the LEDs 120 and fluorescent bulbs 110, as would be understood by one of ordinary skill in the art. Alternatively, separate boards may be provided for LEDs 120 and compact fluorescent bulbs 110. Electrical power is supplied to board 160 through its electrical connection (not shown) to connector 150, which receives power when mated with a conventional light socket.

[0042] Control board 160 may also include a processor 166 that may use various combinations of software and hardware to control the various lighting functions. With respect to LEDs 120, the control may involve control of the color to be emitted by LEDs 120, individually or as a group, when perceived by a user from outside of housing 130 (this may involve the use of a diffuser or the like). In addition, the control mechanisms may control the brightness of the LEDs 120. Further, the control may involve the running of predetermined lighting presentations (e.g., light shows) that vary the light color, brightness, activation, etc., over the course of the presentation to provide an entertaining lighting show. The control mechanisms may also control the compact fluorescent bulbs 110, including their brightness or activation. In preferred embodiments, the compact fluorescent bulbs 110 are activated on their own, without LEDs 120, to provide normal white light for illuminating a room or other area. The LEDs may be used separately as night lights or to provide ambience using color features or color shows that are pleasing to a user.

[0043] The light shows may be stored in a memory 168, which may also be included on the control board 160 (or integrated with processor 166). The memory 168 may include software programs for controlling the circuit board 160 and/or processor 166 to operate the predetermined presentations.

[0044] A user interface 170 is provided on base 140 so as to provide a user with control of the control board 160 and/or processor 166. The user interface may allow the user to select the colors, brightness, activation, etc. of the LEDs 120 and compact fluorescent bulbs 110. In the depicted embodiment, the user interface 170 is a button which a user can toggle to switch between different settings. In other embodiments, user interface 170 may be more elaborate (and be provided at base 140, or remote locations) so as to allow a user more sophisticated control of the operation of the bulb 100. This could include the ability to design programs including color changes, changes in brightness of various components, timed activations and/or deactivations, etc., and combinations thereof.

[0045] FIGS. 7-9 show a modification of the bulb shown in FIGS. 6A and 6B. In particular, there are provided three compact fluorescent bulbs 110 (which may include three distinct fluorescent bulbs or three distinct lengths of light emission of a single fluorescent bulb). Again, the separate compact fluorescent bulbs 110 are provided so as to extend from the base 140 vertically up through the housing 130 to a position near the top thereof. In this embodiment, however,

LEDs 120 are not arranged circularly around the compact fluorescent bulbs 110 near the base 140, but are arranged in vertical groupings, each grouping extending between separate compact fluorescent bulbs 110. As shown in FIG. 9, each grouping of LEDs 120 extending between adjacent compact fluorescent bulbs 110 may be secured to a separate LED board 122. This provides a slightly different lighting effect that may distribute colored light more effectively.

[0046] With the above-described various embodiments, our invention provides a bulb similar in size, shape and compatibility to conventional light bulbs, but with enhanced features and control, including colors, color changing and light shows. However, because our invention still mates with conventional light sockets, and is generally shaped similarly to that of a conventional incandescent bulb (at least in one embodiment), it may be used in existing light fixtures and accommodate conventional light shades. Specifically, housing 130 is preferably shaped/sized so as to be able to receive the connection means provided on conventional light shades to secure the same to typical light bulbs. In particular, with respect to FIG. 6A, the diameter of housing 130 at position 132 (a wider top portion of housing 130) is preferably in the range of about 1.75 to about 3.25 inches, and the diameter of housing 130 at position 134 is preferably about 1 to about 3 inches. Most preferably the of the bulb substantially complies with conventional bulb sizes A-19 (with position 132 measuring about 2.375 inches) and A-21 (with position 132 measuring about 2.625 inches).

[0047] In addition, bulb 100 preferably emits white light from compact fluorescent bulbs, or other light emission devices in a range of about 160 to about 4200 lumens; and more preferably in the range of about 240 to about 2625 lumens; and most preferably in the range of about 320 to about 2100 lumens. Also, a bulb according to our invention preferably draws power in the range of about 5 to about 200 watts; and more preferably in a range of about 15 to about 125 watts; and most preferably in a range of about 25 to about 100 watts. Consequently, our invention is designed for use in many settings where conventional bulbs would typically be used.

[0048] It should also be recognized, however, that other suitable illumination sources, such as a halogen bulb or high intensity discharge bulb, may be used to provide illumination light, as would be readily understood by one of ordinary skill in the art.

INDUSTRIAL APPLICABILITY

[0049] This invention provides lighting for both illumination purposes and for the creation of ambient conditions in a single device, which may be adjusted manually to change and which may be programmed to automatically change such lighting.

1.-38. (canceled)

39. A light device comprising:

- an illumination source emitting illumination light when supplied with electrical power;
- a plurality of light emitting diodes (LEDs) emitting light when supplied with electrical power;
- a base supporting the light emitting diodes;
- circuitry connecting a supply of electrical power to the illumination source and the LEDs, the circuitry causing the illumination source to emit illuminating light and causing the LEDs to emit light of colored or white light.

40. The light device according to claim **39**, wherein the illumination source is selected from the group consisting of halogen, incandescent, and fluorescent light sources and combinations thereof.

41. The light device according to claim **39**, wherein the circuitry further comprises a circuit that performs two or more of the following functions:

- activating the illumination source without activating the LEDs;
- adjusting an intensity of the illumination source;
- adjusting intensities of any one or more of the LEDs;
- activating the illumination source with the LEDs to emit illumination and colored light;
- activating the LEDs without the illumination source to emit colored light; and
- activating the LEDs to emit white light.

42. The electrical lamp according to claim **39**, wherein the illumination source emits white light.

43. The light device according to claim **39**, wherein the circuitry comprises a dimmer to adjust the intensity of the illumination light.

44. The light device according to claim **39**, wherein the device further comprises a translucent housing connected to the base and covering the illumination source and the LEDs.

45. The light device according to claim **44** wherein the housing is bulbous shaped to give the light device a profile similar to a traditional incandescent light bulb.

46. The light device according to claim **39**, wherein the circuitry further comprises a circuit that can operate the LEDs to produce colored light and or white light.

47. The light device according to claim **39**, wherein the circuitry further comprises a circuit that can be manually operated to select the color produced by the LEDs.

48. The light device according to claim **39**, further comprising a sensor for sensing at least one of temperature, scent, motion, and sound, and the circuitry adjusting the intensity of at least one of the LEDs in response to a signal from the sensor.

49. A light device comprising:

- an illumination source, chosen from the group consisting essentially of incandescent, fluorescent and halogen light emitting devices for emitting illumination light;
- a plurality of light emitting diodes (LEDs);
- a base on which the illumination source and the plurality of light emitting diodes are mounted in proximity to each other, the base being configured to be coupled to an electrical supply;

circuitry connected to supply electrical power to the illumination source and the LEDs, the circuitry further comprising a circuit connected to the circuitry and configured to adjust the intensities of the light emitted by the LEDs according to at least one predetermined program, and the circuitry comprising a memory for storing and recalling the at least one predetermined program.

50. The light device according to claim **49**, wherein the circuitry comprises a dimmer to adjust the intensity of the illumination light.

51. The light device according to claim **49**, further comprising a sensor for sensing at least one of temperature, scent, motion, and sound, and the circuit adjusting at least one of the intensities of the light emitted by the LEDs or illumination source in response to a signal from the sensor.

52. A light device comprising:

- a base coupled to an electrical supply;
- a compact fluorescent light (CFL) supported by the base;
- a plurality of light emitting diodes (LEDs) mounted on the base;

control circuitry which supplies power from the electrical supply to the CFL and the plurality LEDs, the control circuitry comprising a processor for controlling the plurality of LEDs to produce at least one predetermined presentation of light emission which varies, during the presentation, at least one of the color and intensity of light emitted by the plurality of LEDs.

53. The light device according to claim **52**, wherein the plurality of LEDs are positioned circumferentially around the base.

54. The light device according to claim **53**, wherein adjacent LEDs, in a circumferential direction, are different color LEDs.

55. The light device according to claim **52**, wherein the CFL, the LEDs, the control circuitry and processor are powered from a common circuit board.

56. The light device according to claim **52**, further comprising a user interface connected to the control circuitry, wherein the user interface allows for changing of the color of the light to be emitted from the LEDs.

57. The light device according to claim **52**, further comprising a memory for storing a plurality of predetermined presentations.

58. The light device according to claim **57**, further comprising a user interface for selecting from the plurality of predetermined presentations.

59. The light device according to claim **52**, wherein the processor performs two or more of the following functions:

- activating the CFL without activating the LEDs;
- adjusting the intensity of the CFL;
- adjusting intensities of the LEDs;
- activating the CFL with the LEDs to emit illumination and colored light;
- activating the LEDs without the CFL to emit colored light; and
- activating the LEDs to emit white light.

60. The light device according to claim **59**, wherein the processor is controlled remotely with a remote control.

* * * * *