



US 20080085221A1

(19) **United States**

(12) **Patent Application Publication**  
**Downs**

(10) **Pub. No.: US 2008/0085221 A1**

(43) **Pub. Date: Apr. 10, 2008**

(54) **HIGH THROUGHPUT MECHANICAL ALLOYING AND SCREENING**

**Related U.S. Application Data**

(75) Inventor: **Robert Charles Downs**, La Jolla, CA (US)

(63) Continuation of application No. 11/671,047, filed on Feb. 5, 2007, which is a continuation-in-part of application No. PCT/US06/30257, filed on Aug. 2, 2006, which is a continuation-in-part of application No. 11/197,180, filed on Aug. 3, 2005.

Correspondence Address:

**TIMOTHY L. SMITH**  
**14740 CAMINITO PORTA DELGADA**  
**DEL MAR, CA 92014 (US)**

**Publication Classification**

(73) Assignee: **WILDCAT DISCOVERY TECHNOLOGIES, INC.**, San Marino, CA (US)

(51) **Int. Cl.**  
*B01L 5/00* (2006.01)  
*B01L 11/00* (2006.01)  
*B01L 3/00* (2006.01)

(52) **U.S. Cl.** ..... **422/102; 422/103**

(21) Appl. No.: **11/841,768**

(57) **ABSTRACT**

(22) Filed: **Aug. 20, 2007**

The invention provides an apparatus and methods for high throughput screening of alloys and other materials to identify those that have desired gas storage properties.

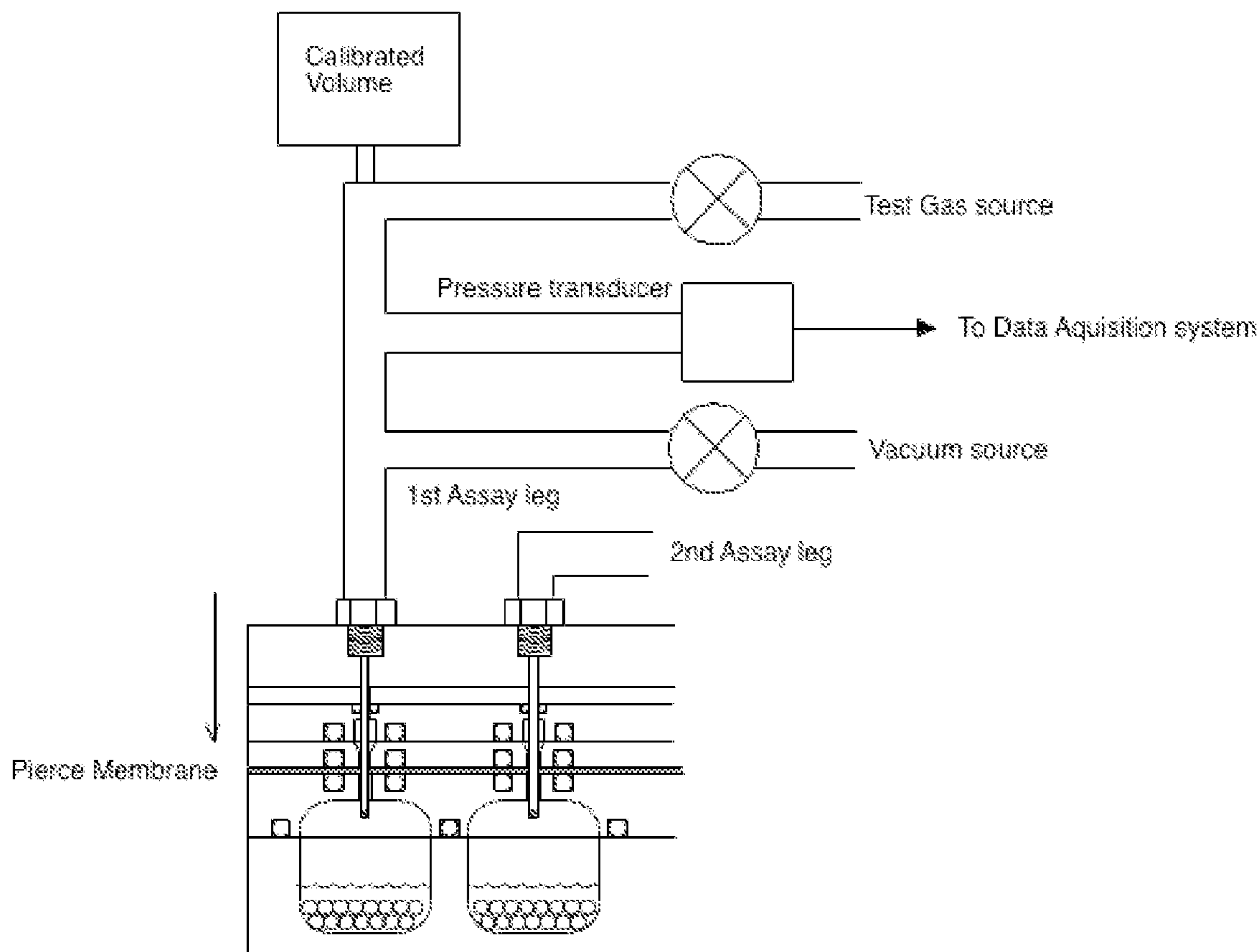

Figure 1

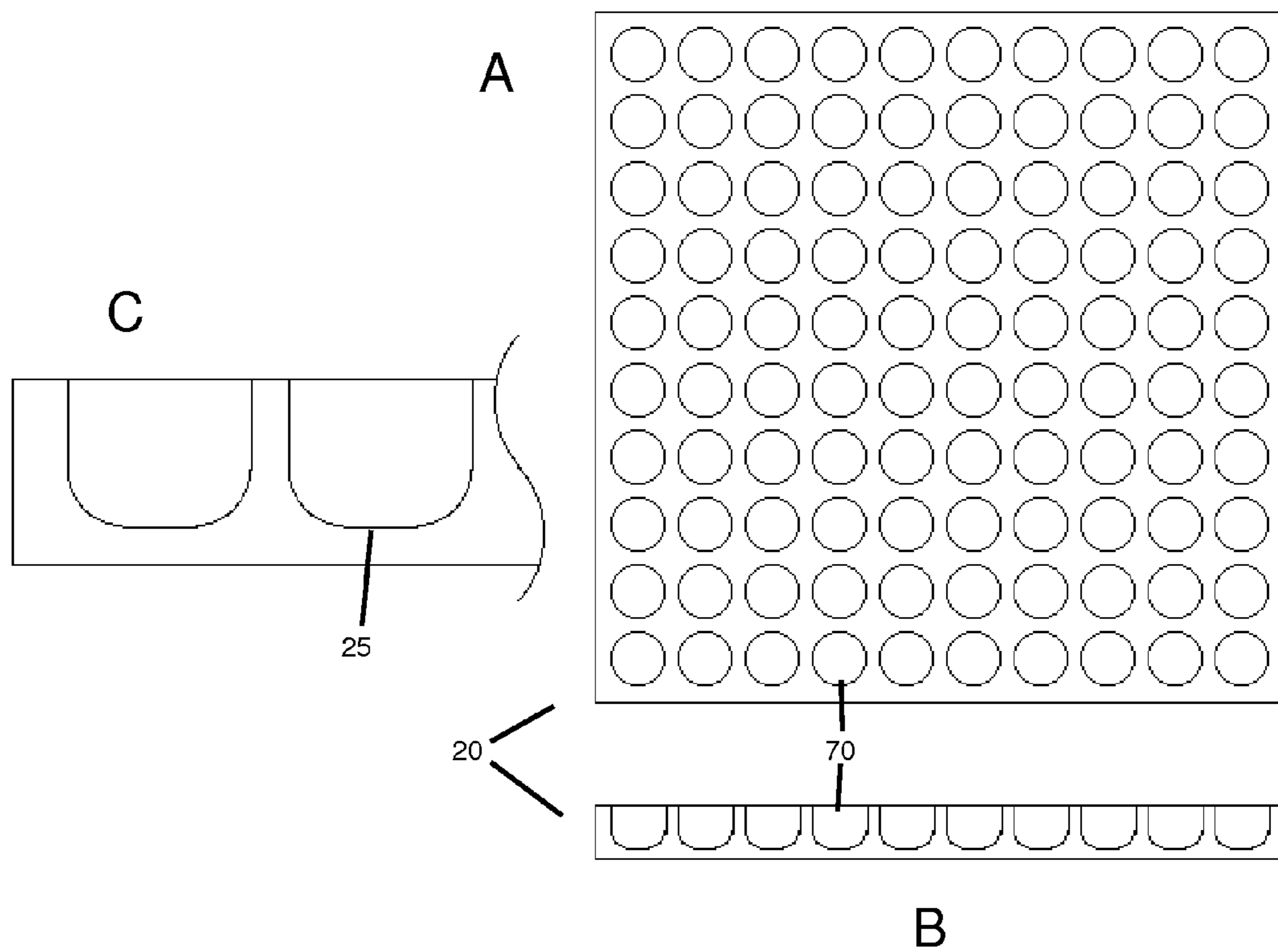

Figure 2A

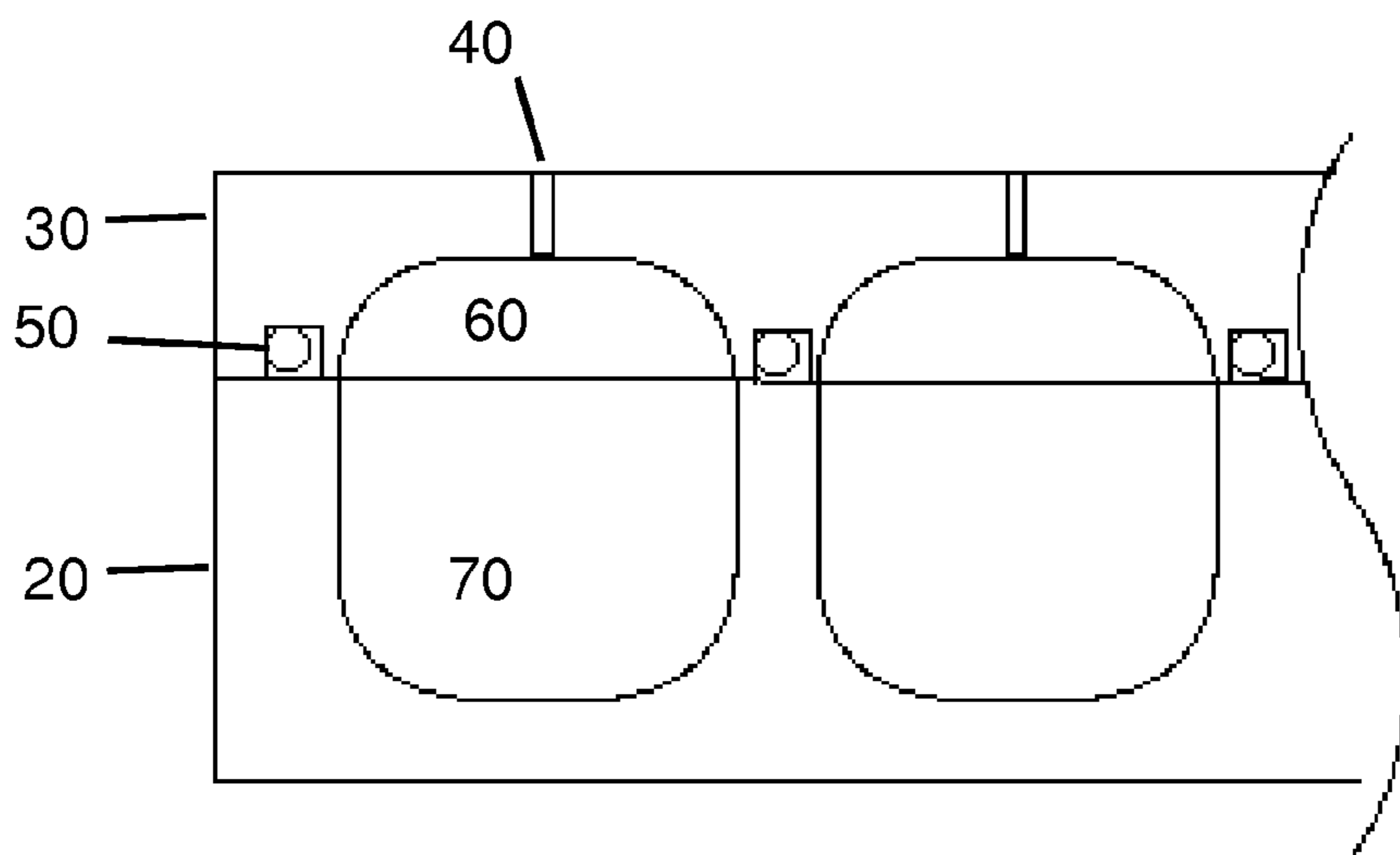

Figure 2B

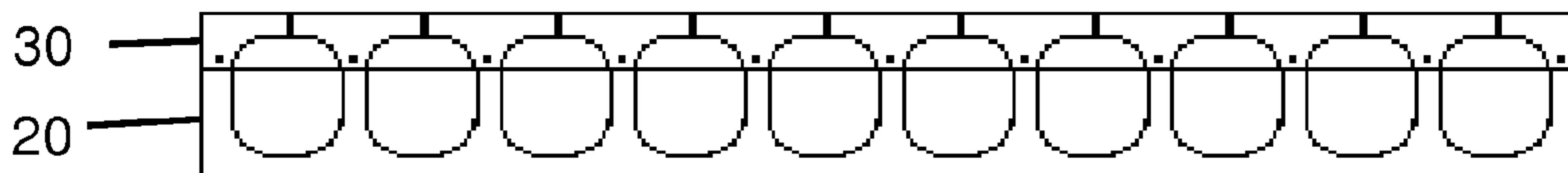

Figure 3A

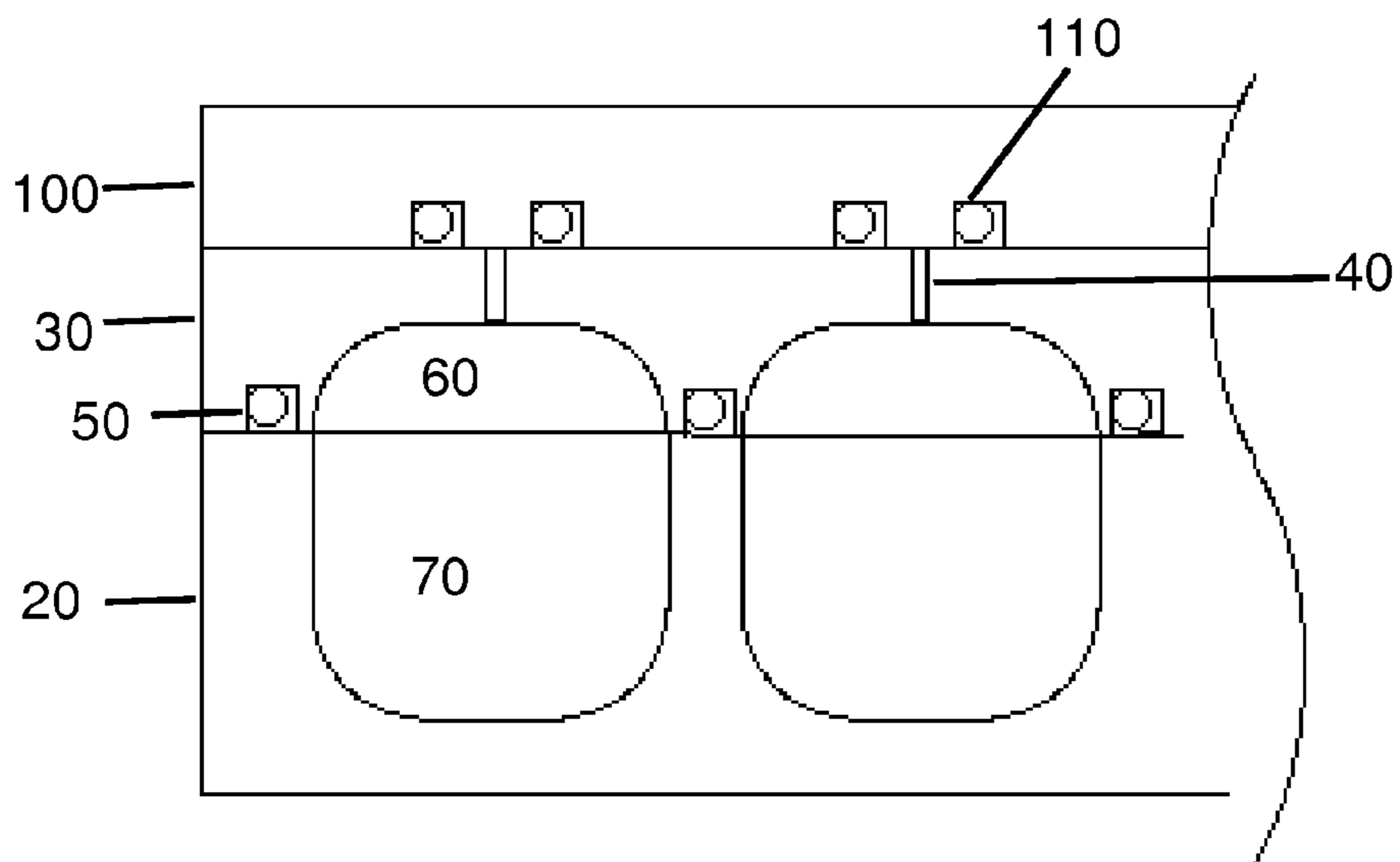

Figure 3B

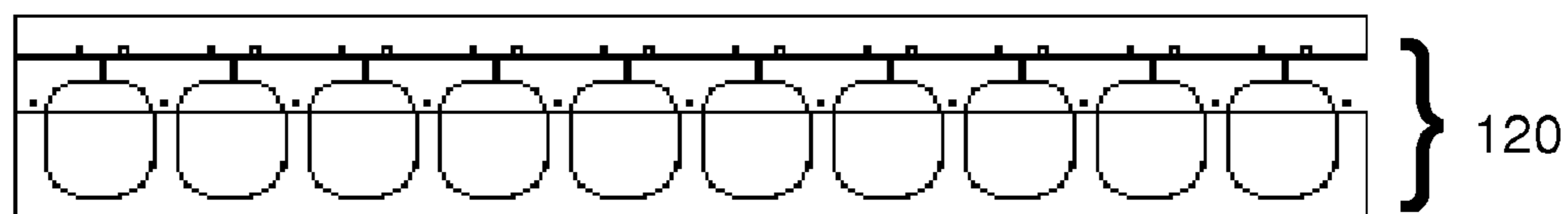

Figure 4

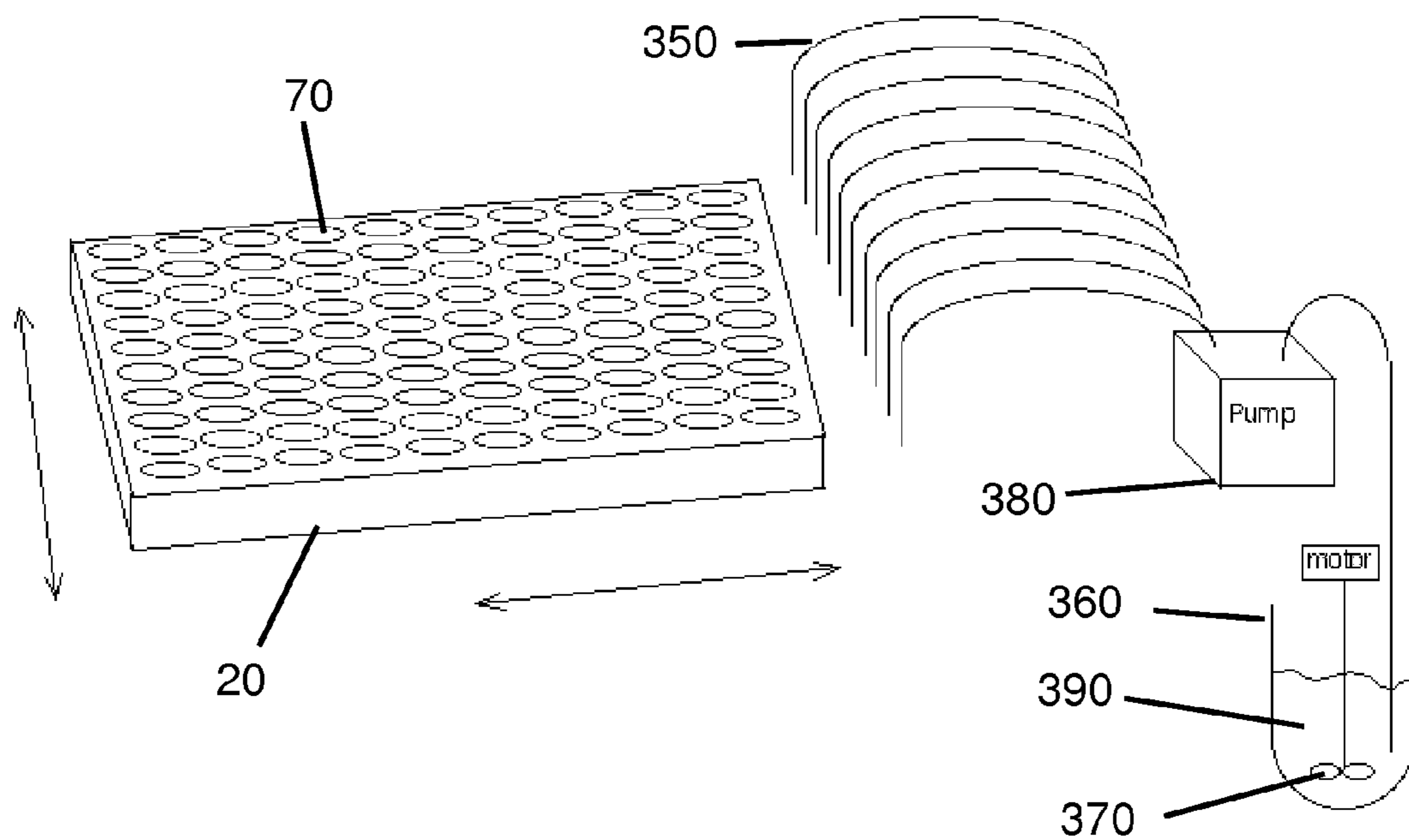

Figure 5

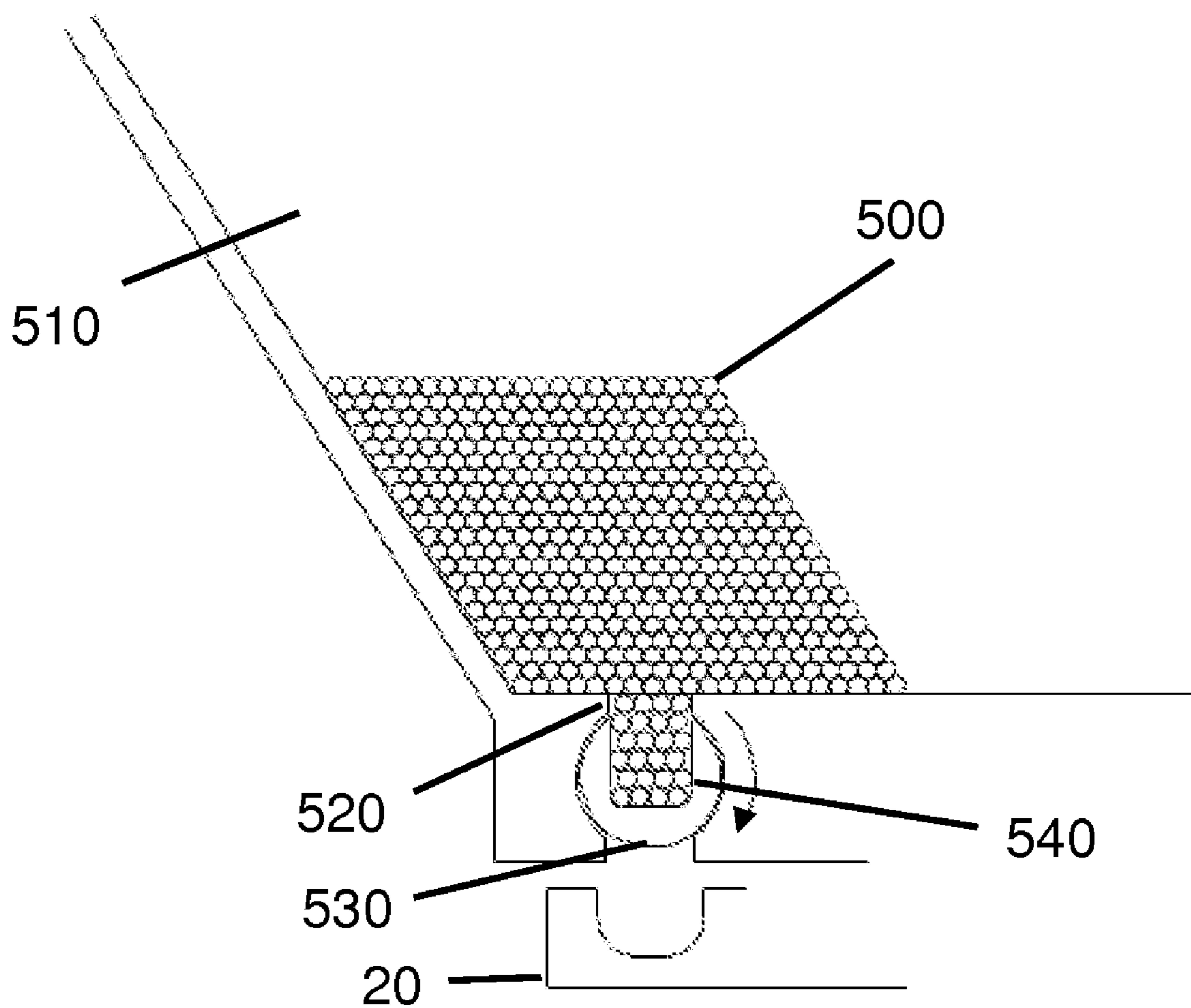

Figure 6

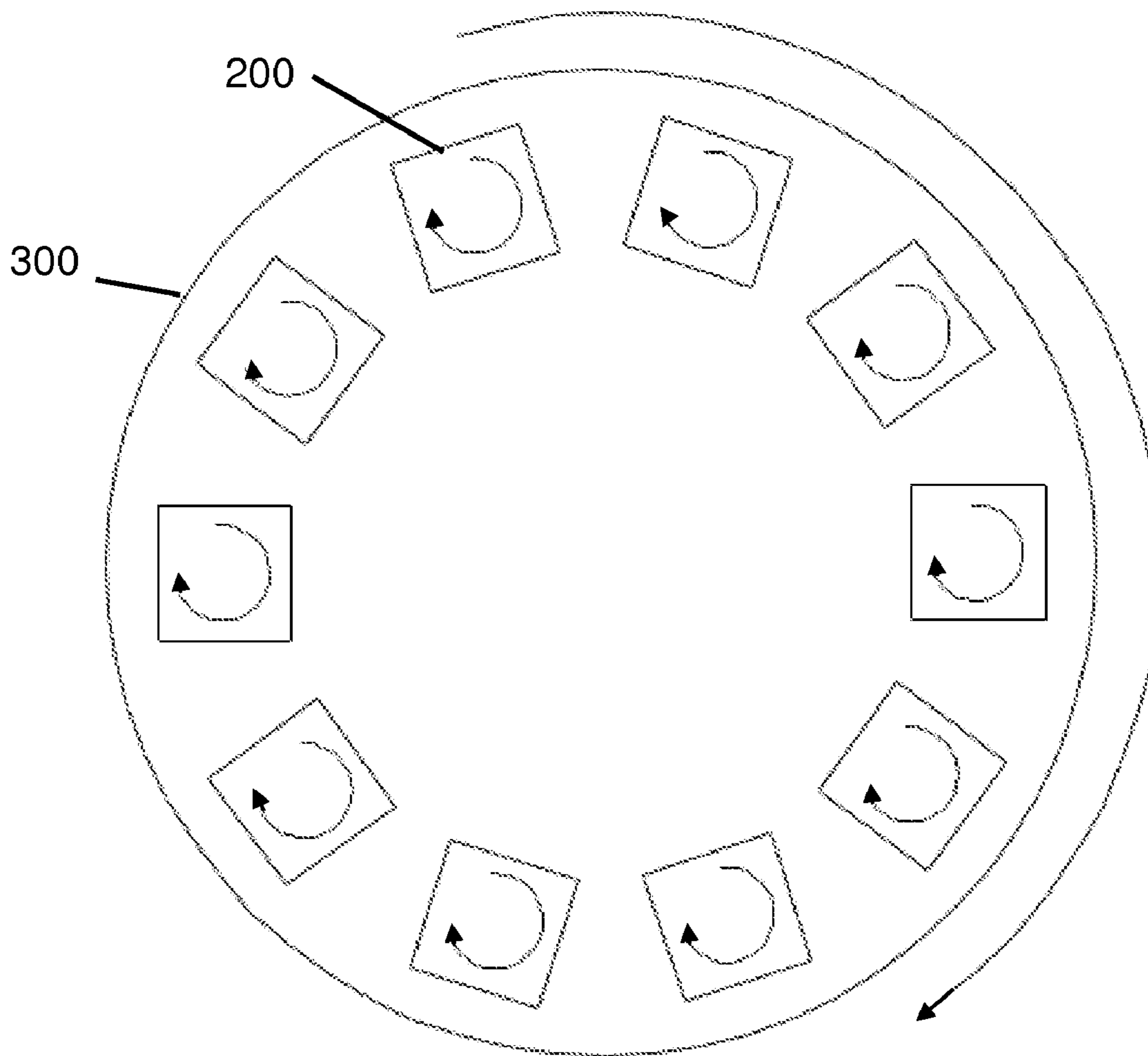

Figure 7

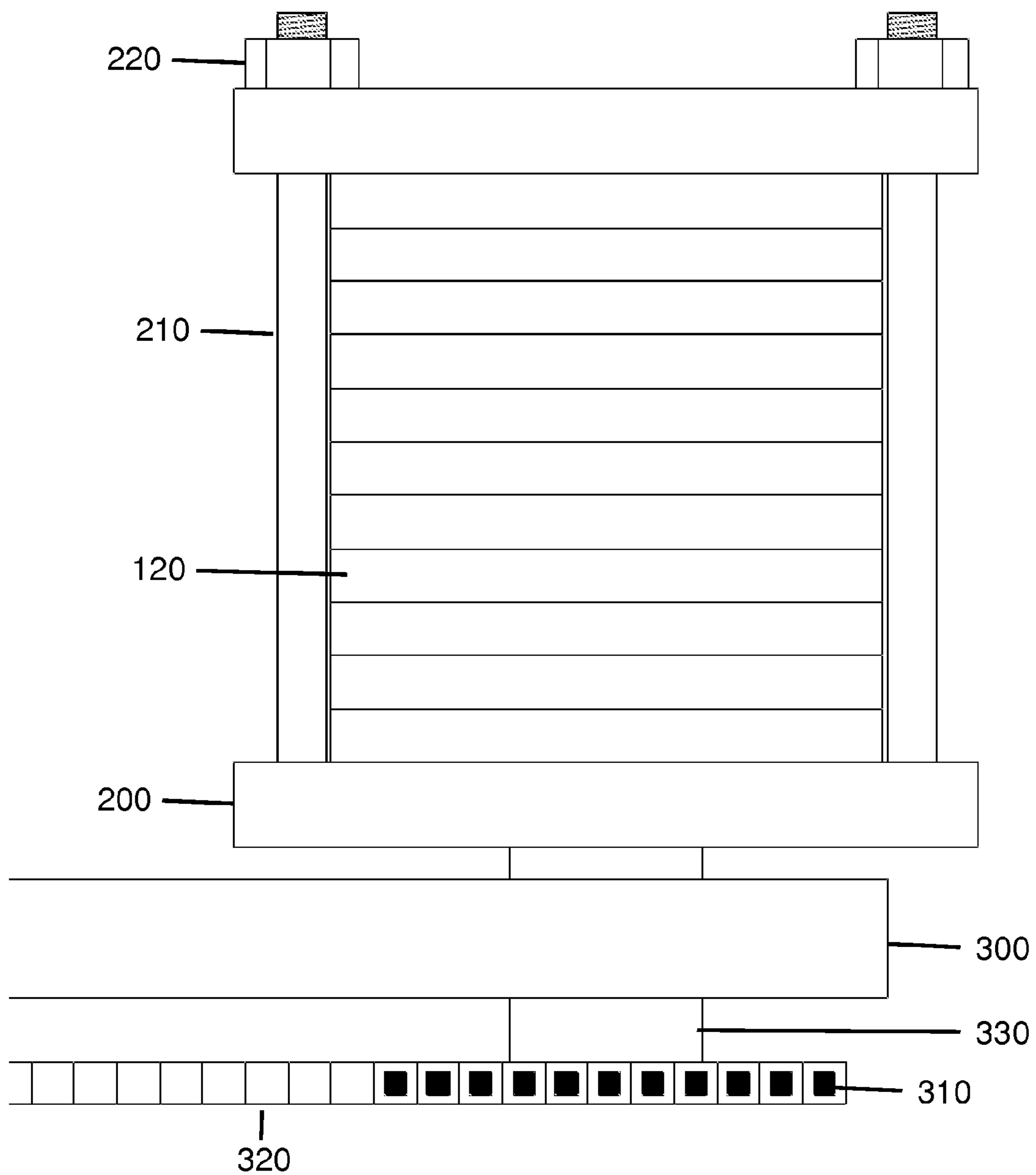



Figure 8

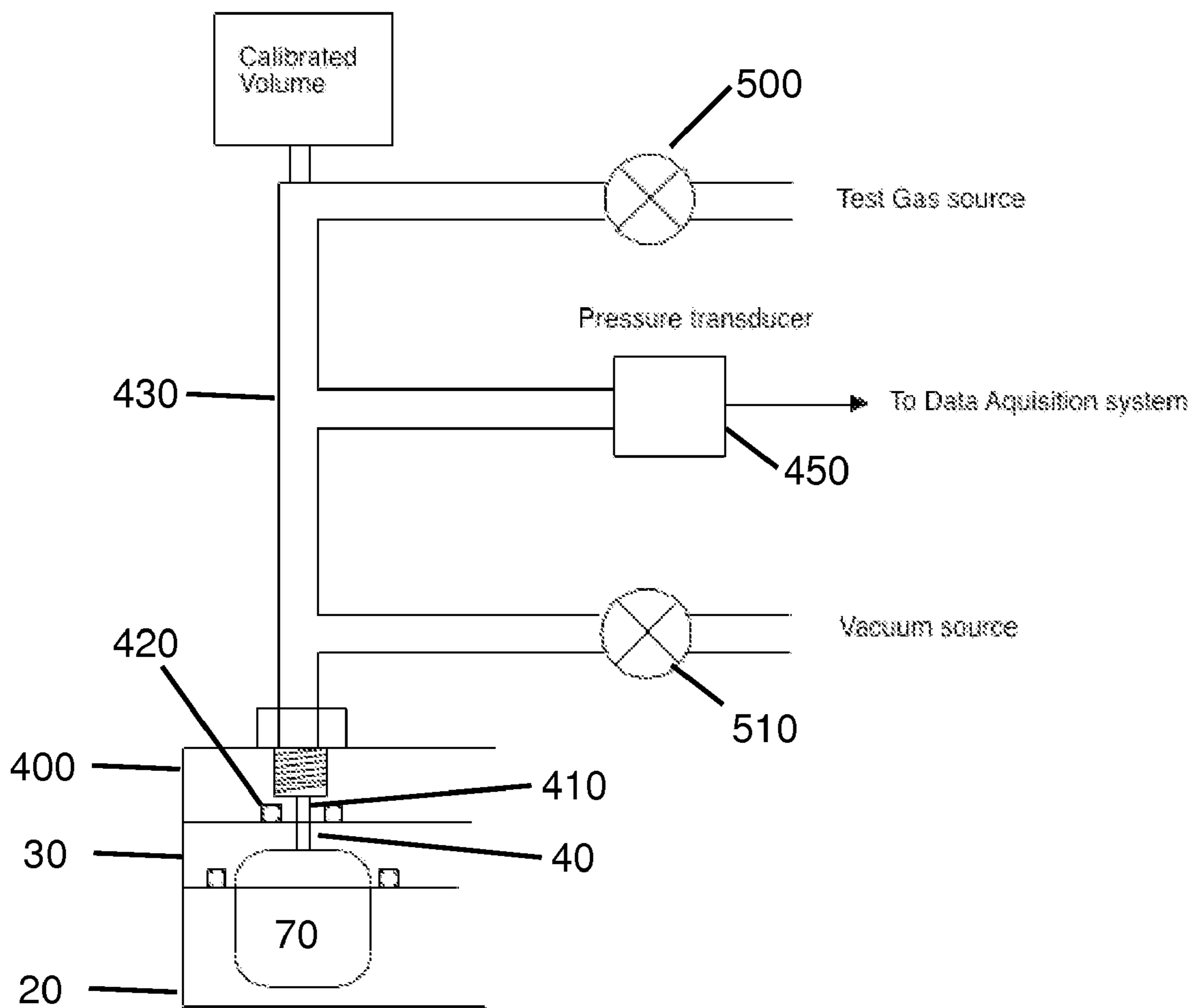

Figure 9

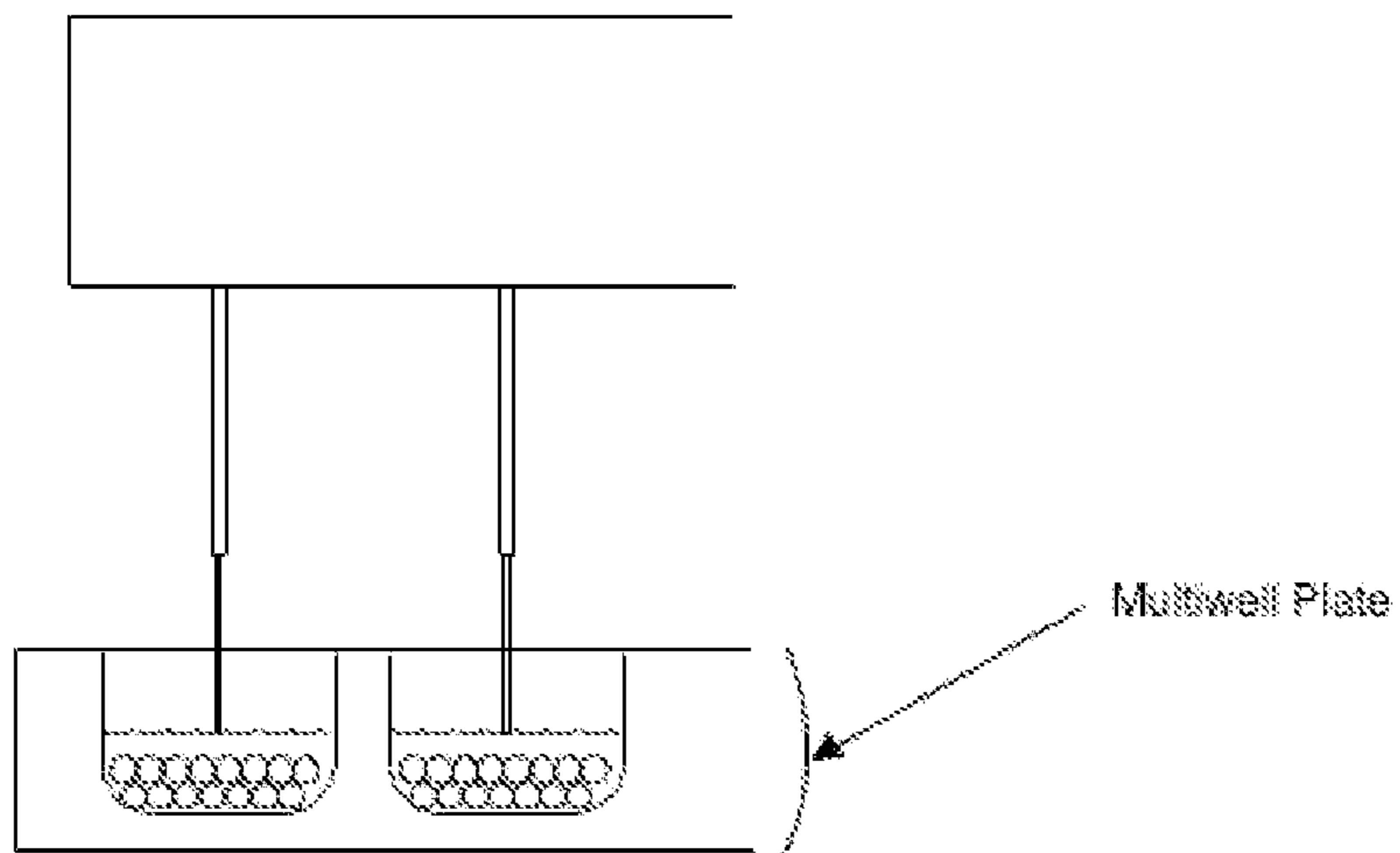

Figure 10

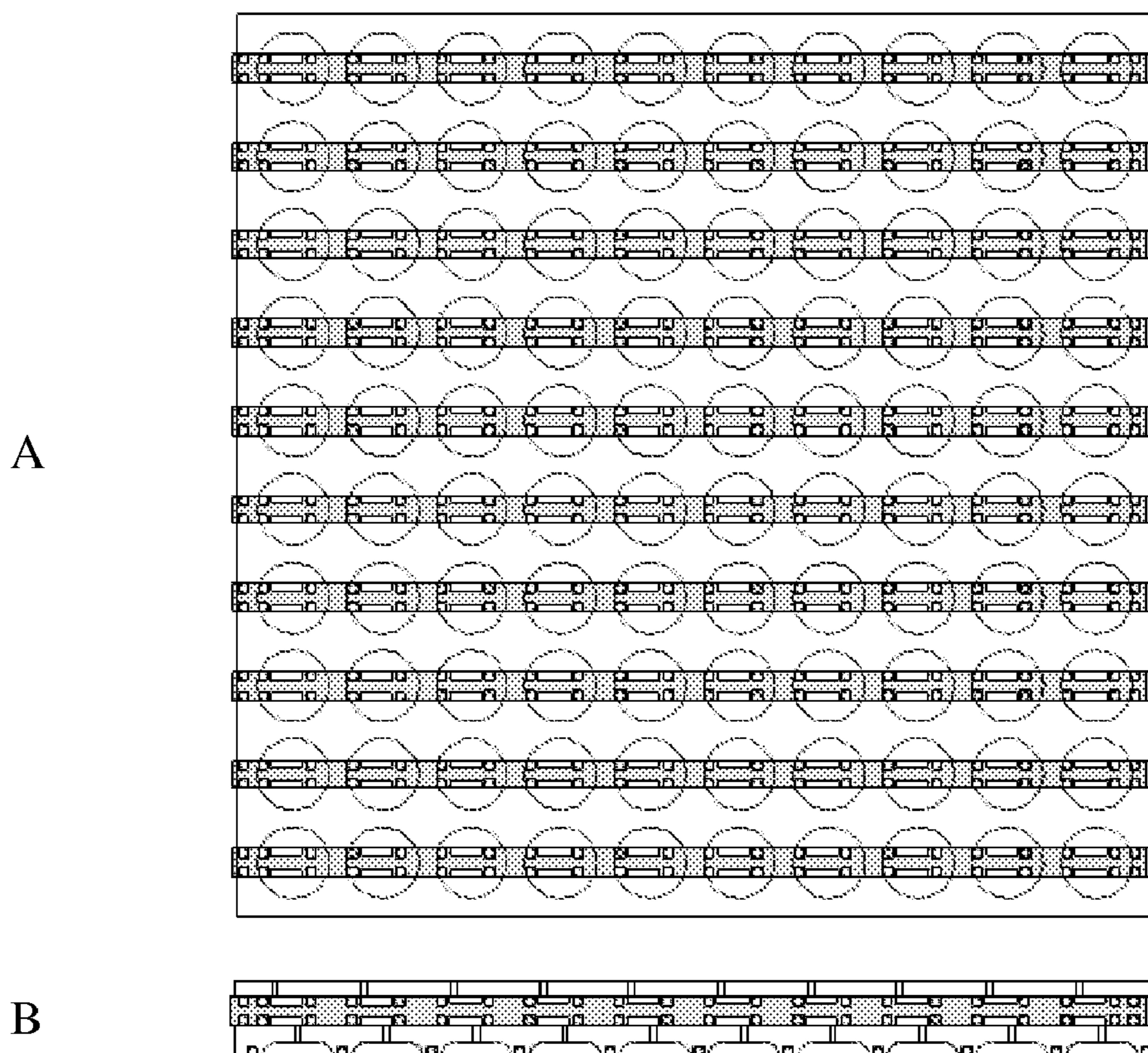

Figure 11A

Valves Open

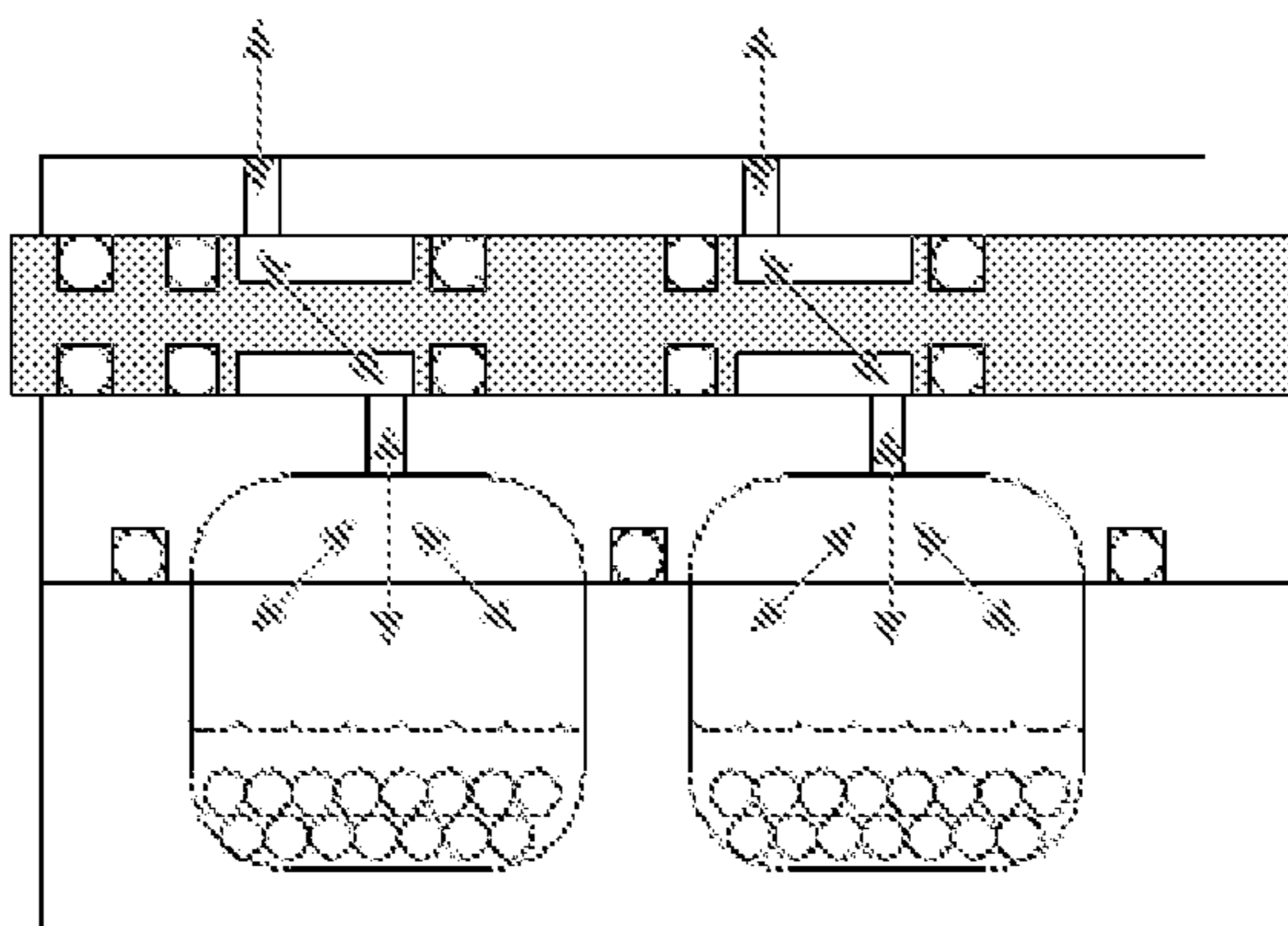

Figure 11B

Valves Closed

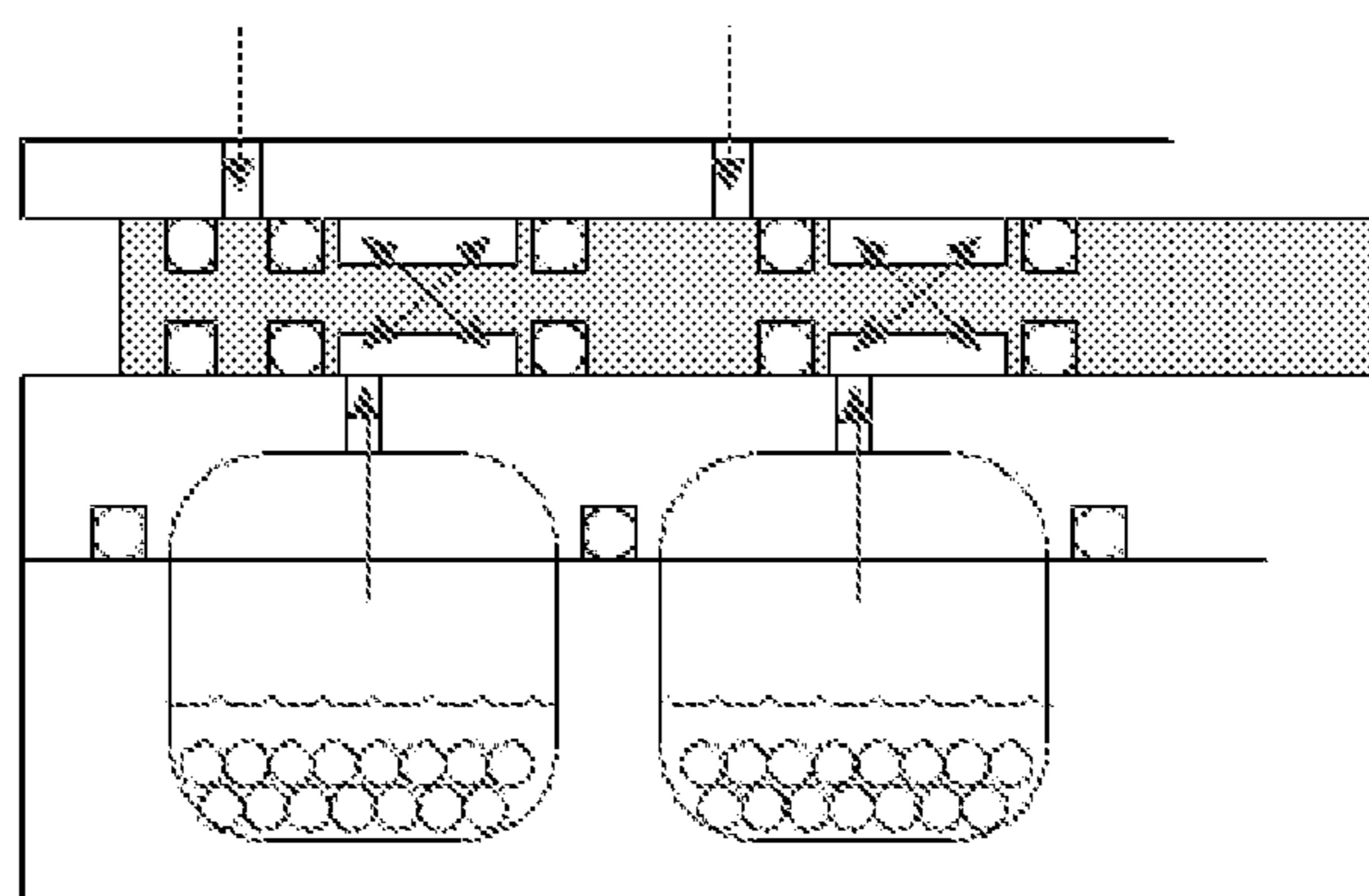

Figure 12

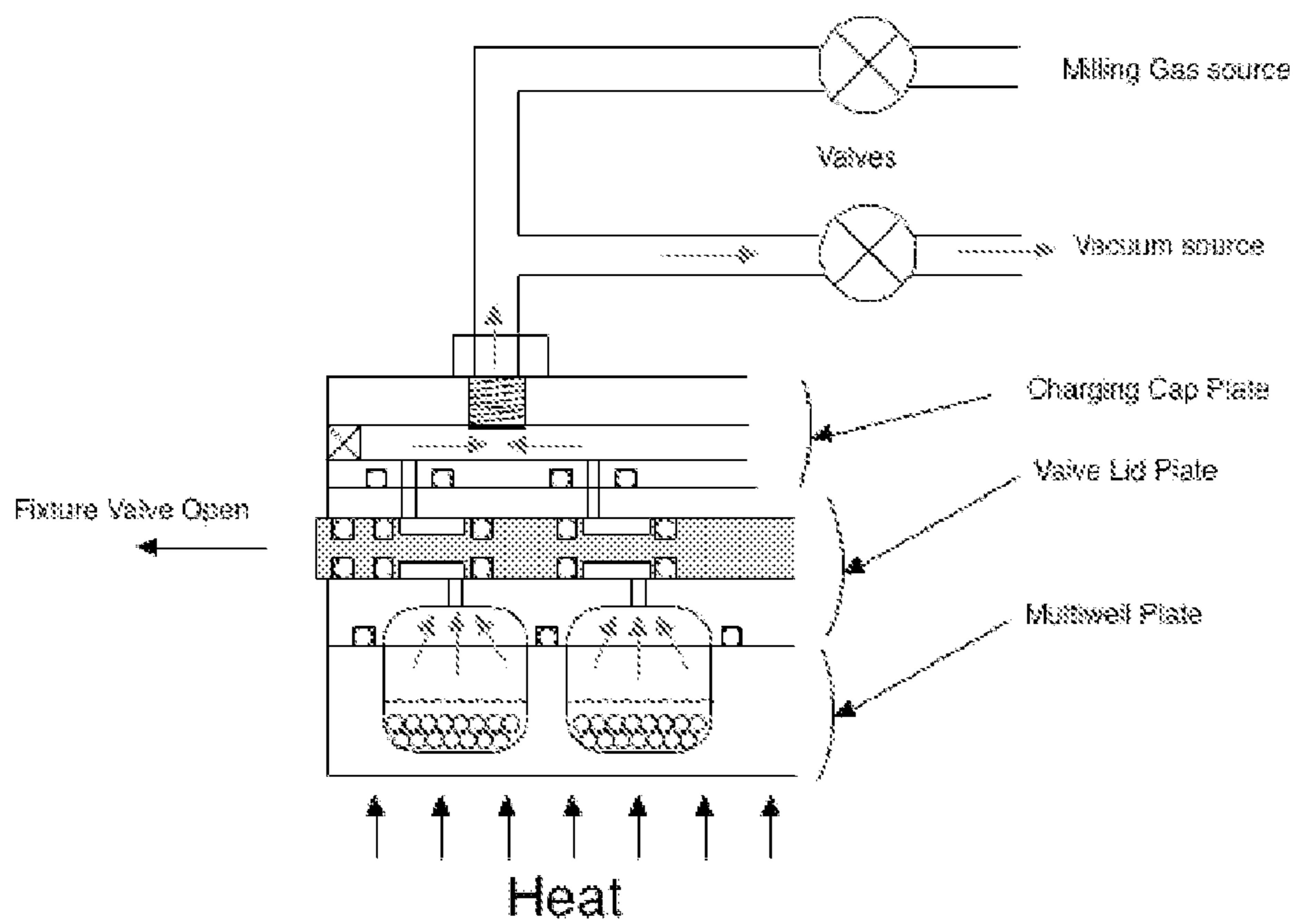

Figure 13

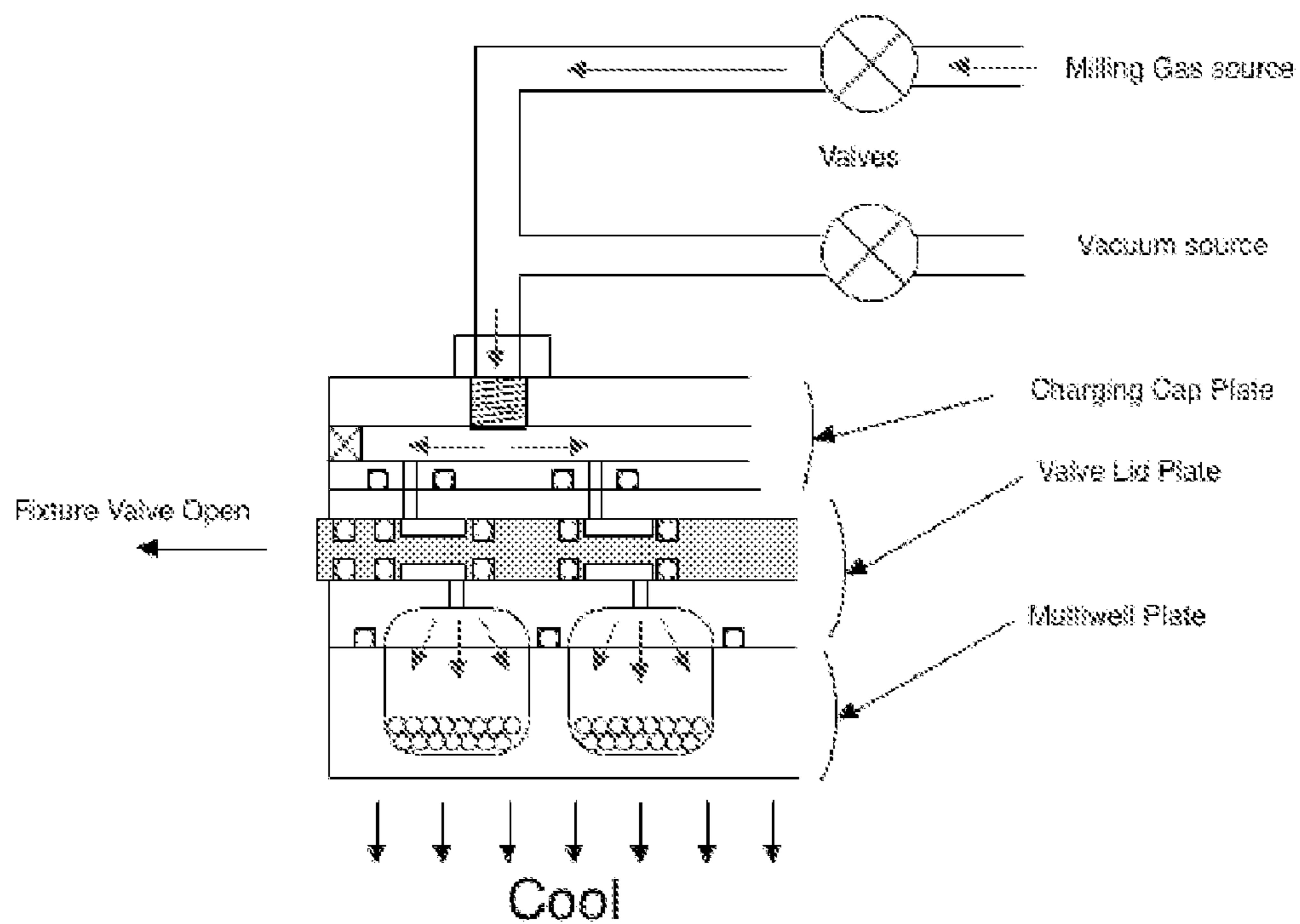

Figure 14

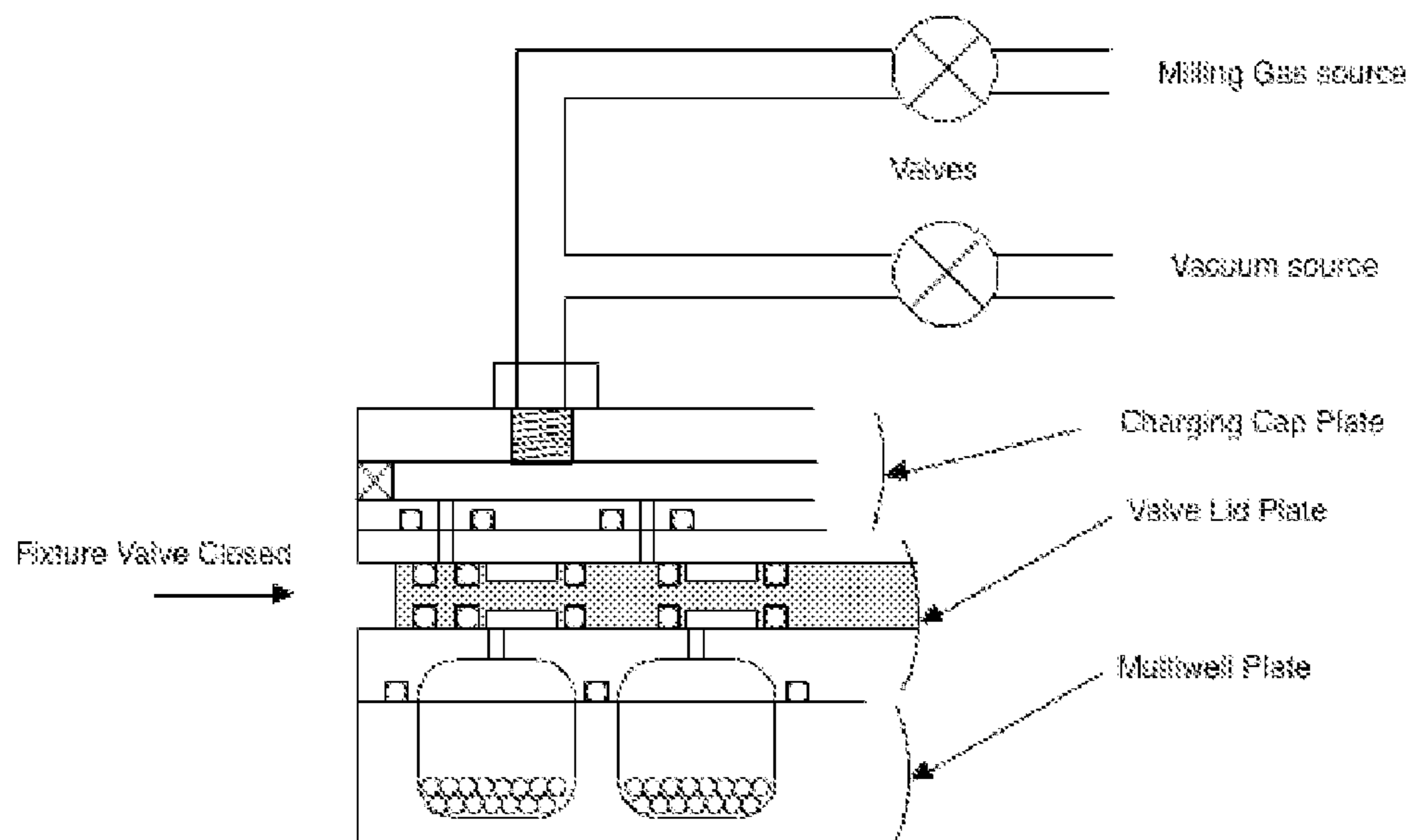

Figure 15

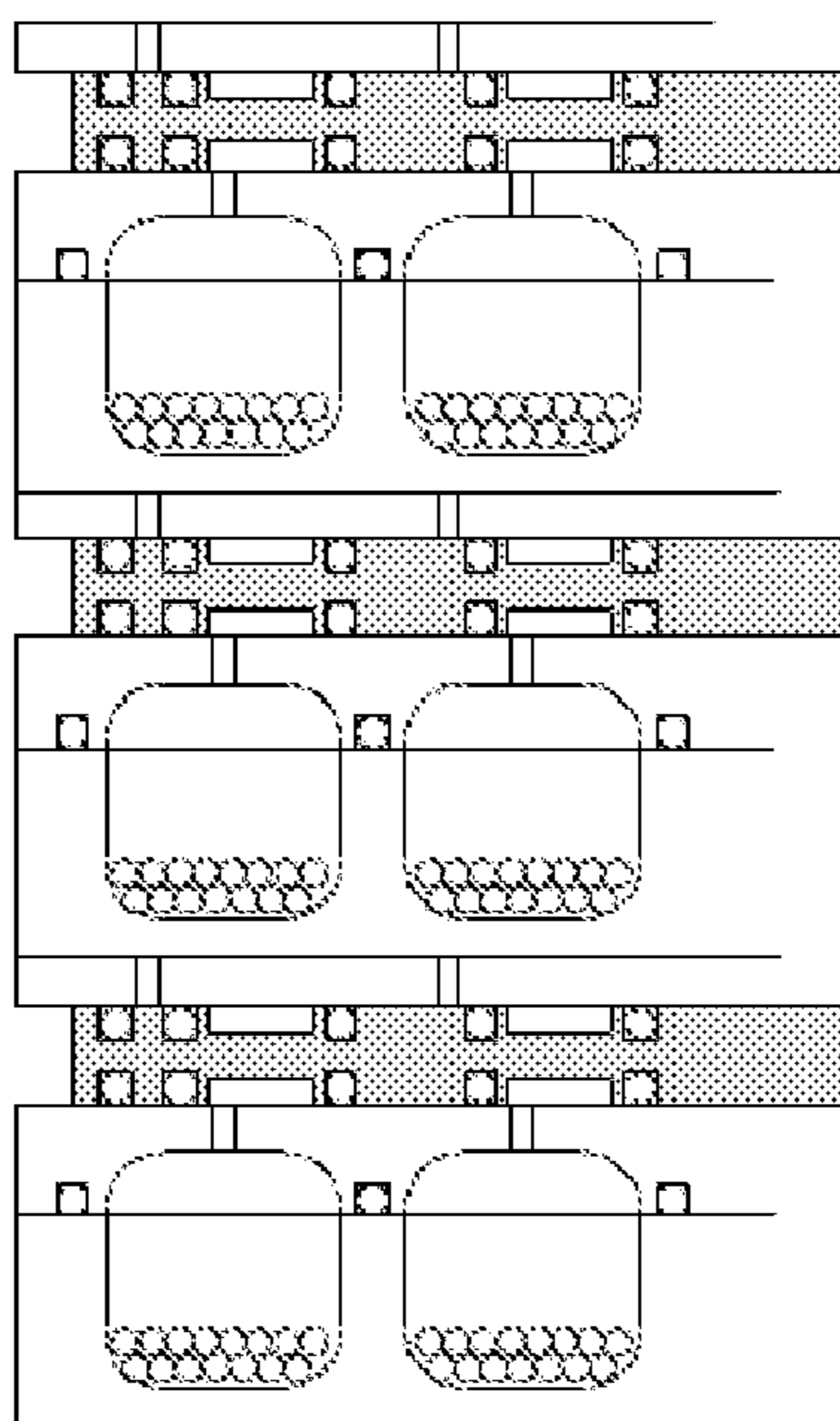

Figure 16

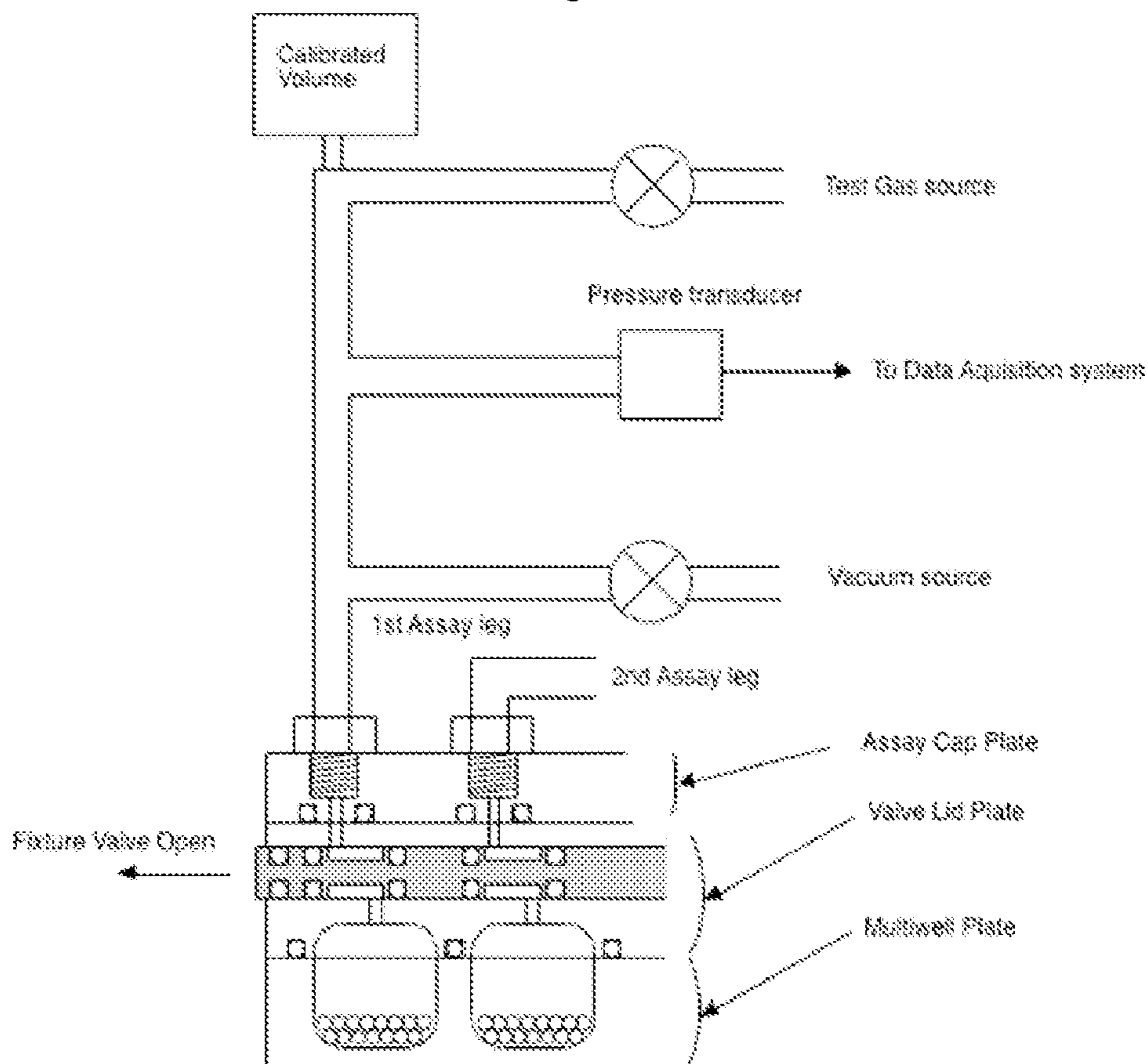

Figure 17

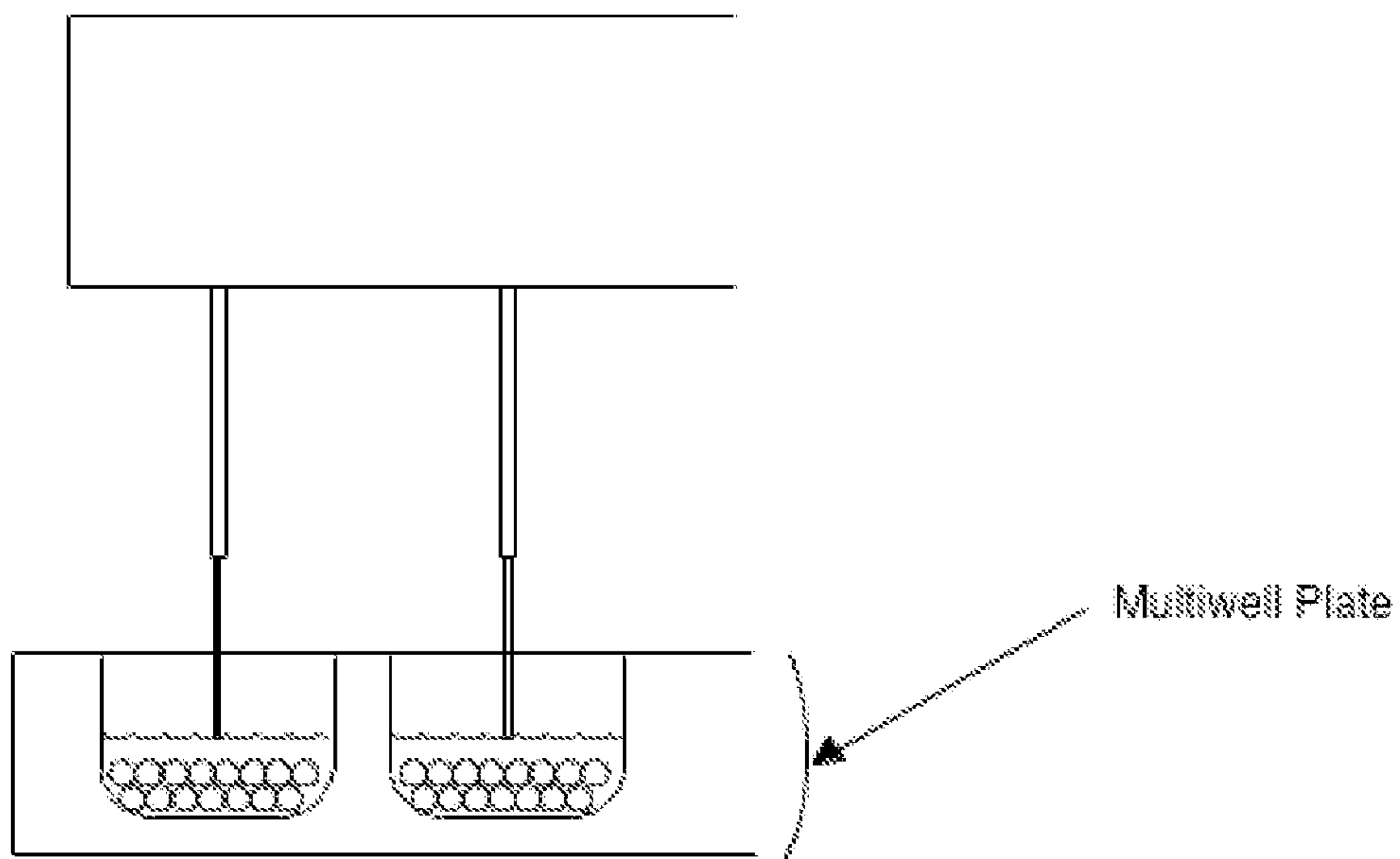
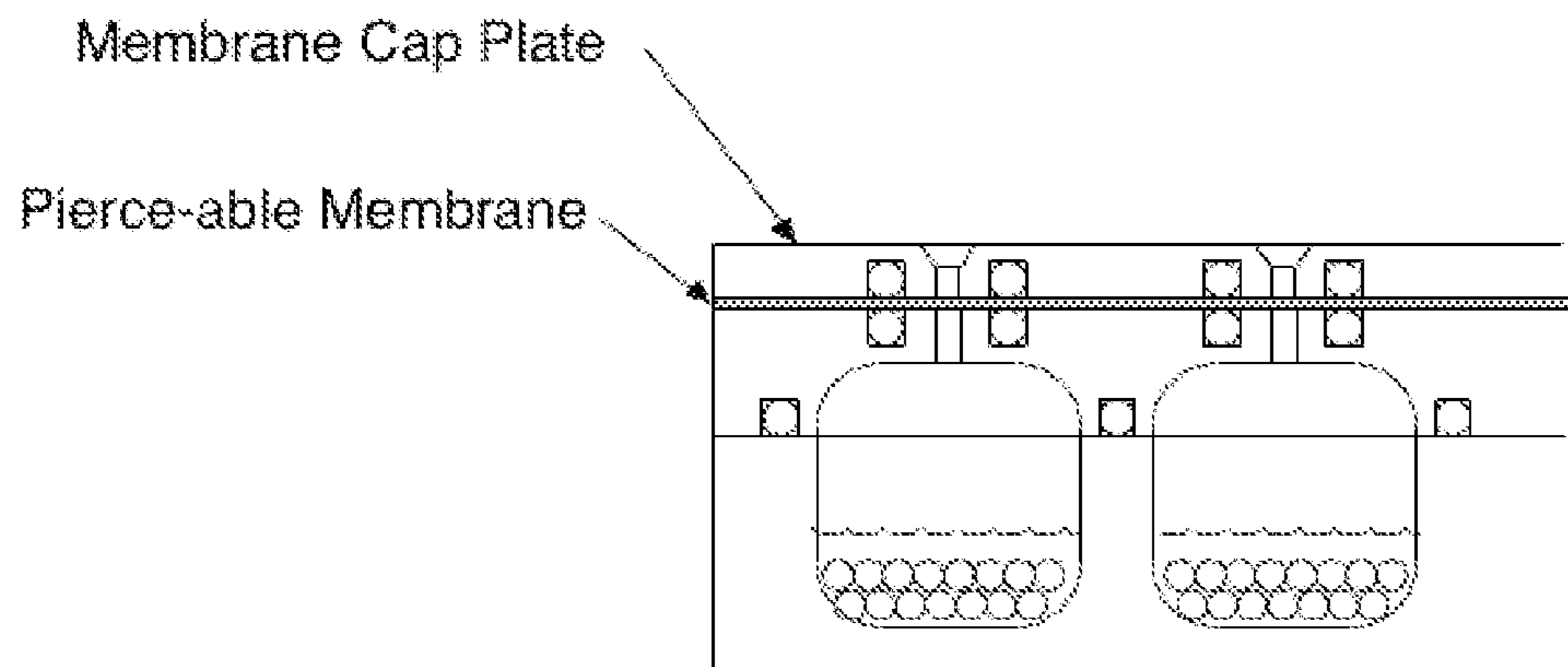

Figure 18



# Figure 19

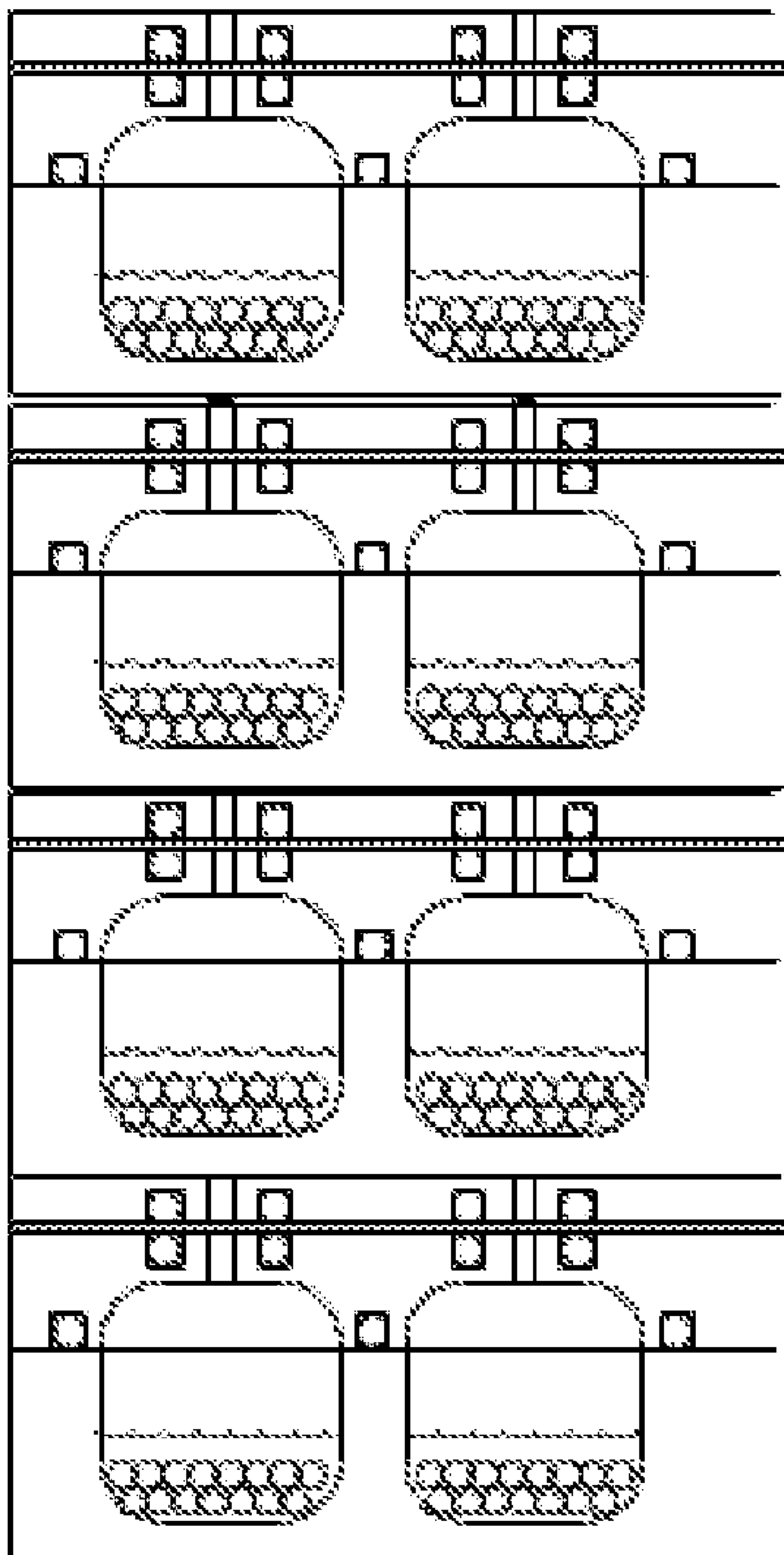

Figure 20

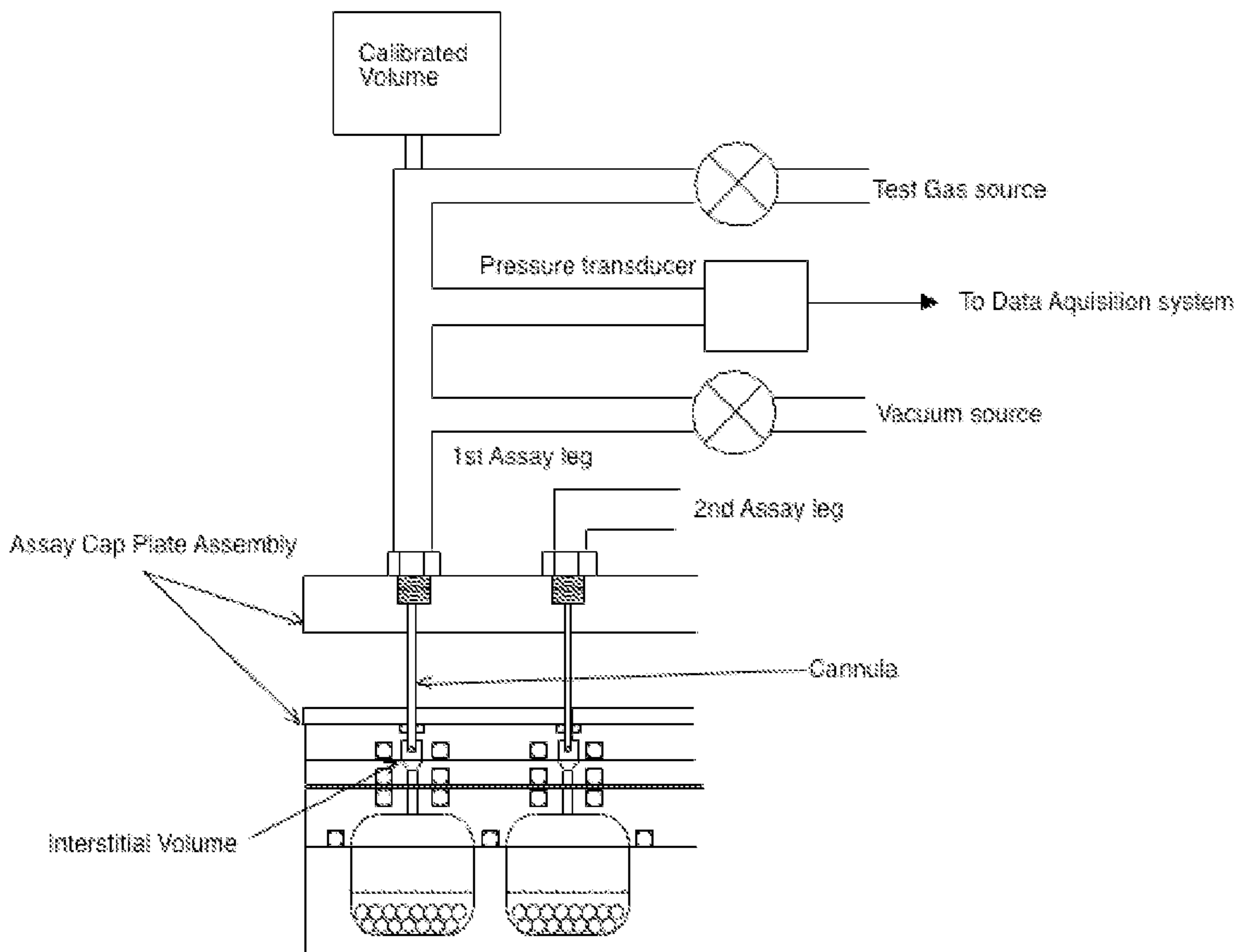



Figure 21

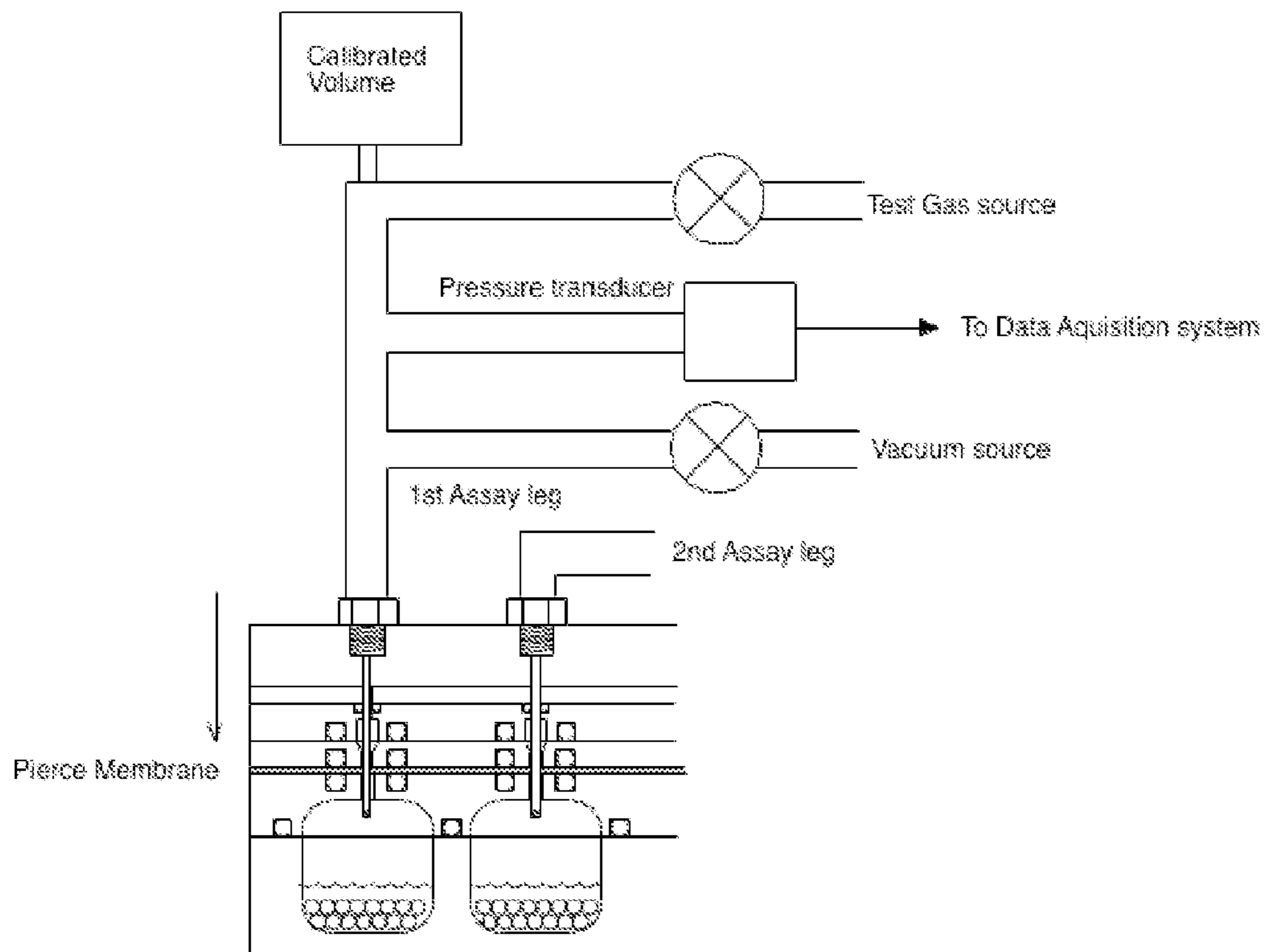
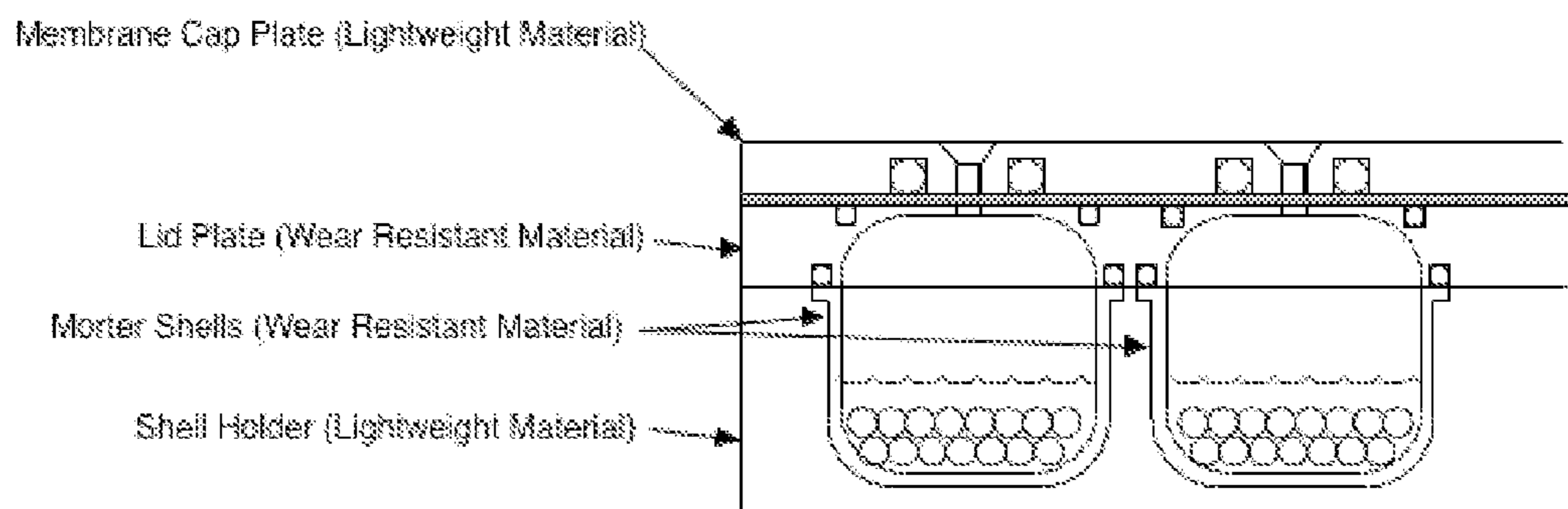

Figure 22



## HIGH THROUGHPUT MECHANICAL ALLOYING AND SCREENING

### CROSS-REFERENCE TO RELATED APPLICATIONS

[0001] This application is a continuation of U.S. application Ser. No. 11/671,047, pending, which was filed Feb. 5, 2007. U.S. application Ser. No. 11/671,047 is a continuation-in-part of U.S. application Ser. No. 11/197,180, pending, which was filed Aug. 3, 2005, and claims priority to international patent application no. PCT/US2006/030257, filed Aug. 2, 2006. These applications are incorporated herein by reference for all purposes.

### BACKGROUND OF THE INVENTION

[0002] 1. Field of the Invention

[0003] The present invention relates to an apparatus and methods for simultaneously producing multiple alloys of ultra-fine powder particles, and for high-throughput assaying of the alloys to identify those having desired gas storage properties.

[0004] 2. Background

[0005] Materials science has shown that materials having a desired property can often be found by making a massive library of different materials from various combinations of precursor substances and assaying the resulting materials for the desired property.

[0006] One method that is suitable for making different materials is mechanical alloying, which was invented by J. S. Benjamin and is described in U.S. Pat. No. 3,591,362. Mechanical alloying involves forming alloys from pure starting materials by milling a mixture of the powders in a high energy ball mill. During the milling, the starting particles undergo repeated collisions with grinding balls, causing deformation, welding and fracture of the particles which result in microstructural refinement and composition changes leading to the formation of nanocrystalline or amorphous alloys. The process can result in two or more particulate starting substances becoming so intimately mixed that the resulting particulate product is either a true alloy or a remarkably homogenous blend, or a combination of a true alloy and a homogeneous blend.

[0007] Previously known devices and methods for mechanical alloying are not suitable for forming the massive libraries of materials that are necessary for optimal screening to identify materials that have desired properties. Therefore, a need exists for a mechanical alloying apparatus and methods for the production of large libraries of different materials in a high throughput manner. The present invention fulfills this and other needs.

### SUMMARY OF THE INVENTION

[0008] The invention provides a multiwell ball milling fixture that is useful for performing multiple ball milling operations in a high throughput manner. In some embodiments, the fixture can be used not only for the ball milling, but also for further operations such as gas storage assays. The fixture includes a multiwell plate and a lid. The multiwell plate has a plurality of sample wells, wherein each sample well has a sidewall and a bottom surface. Generally,

the bottom surface is joined to the sidewall by a rounded surface. The lid has a bottom surface that defines a planar expanse sufficient to cover the sample wells when the lid is placed on the multiwell plate. The lid has a plurality of gas outlet ports that each include: i) a first opening on the bottom surface of the lid that is spatially positioned such that when the lid is positioned on the multiwell plate, the first opening is in fluid communication with a sample well; ii) a second opening in the top surface of the lid; and iii) a valve that regulates gas flow through the gas outlet port.

[0009] The multiwell ball milling fixture typically has one or more seals disposed between the multiwell plate and the lid, which seals allow gas flow between a sample well and an associated gas outlet port but prevent gas flow between sample wells and between a sample well and a non-associated gas outlet port. If a cap is used, the fixture generally has one or more seals disposed between the lid and the cap, which seals prevent gas flow from one gas outlet port to a second gas outlet port associated with a second sample well. When the lid is attached to the multiwell plate and the valve is in a closed position, no gas can flow into or out of the sample wells (i.e., the sample wells are gas-tight or airtight).

[0010] The lids of the multiwell ball milling fixtures can have a plurality of recessed areas on the bottom surface. In some embodiments, the recessed areas have a top surface that is concave relative to the bottom surface of the lid. The recessed areas can, in some embodiments, have a cross-sectional shape that corresponds to the cross-sectional shape of the sample wells. For example, the top surface of the recessed areas can have a concave radius of curvature that is similar to or identical to the radius of the rounded surface that joins the sidewall and the bottom surface of the multiwell plate. The positions of the recessed areas spatially correspond to the positions of the sample wells when the lid is placed on the multiwell plate. In some embodiments, the recessed areas have a diameter that is the same as the diameter of the sample wells.

[0011] In some embodiments, the lids of the multiwell ball milling fixtures have a plurality of valves that regulate gas flow through the gas outlet ports. The valves can be operably connected to each other, for example, such that when a first valve is changed from a closed position to an open position, one or more additional valves are also changed from the closed position to the open position. For example, the lid can include one or more spool valves that each includes a plurality of valve elements, wherein movement of the spool valve in a first direction positions the valve elements in the open position and movement of the spool valve in a second direction positions the valve elements in the closed position. The lid can have one spool valve for each row of gas outlet ports, or one spool valve for each column of gas outlet ports. The spool valves can be inserted into a bore that traverses through the lid.

[0012] The multiwell ball milling fixtures can, in some embodiments, also have a charging cap. The charging caps have a gas portal and a bottom surface that defines a planar expanse sufficient to cover each of the second openings of the plurality of gas conduits of the lid when the cap is positioned on the lid. The charging cap has an air passage that is in fluid communication with each of the second openings and with the gas portal when the charging cap is

placed on the lid. The gas portal is connected to a vacuum source that applies a vacuum to the sample wells when the valves of the lid (if present) are in an open position. The gas portal can also be connected to a milling gas source that introduces a milling gas into the sample wells when the valves of the lid (if present) are in an open position.

[0013] The invention also provides multiwell ball milling fixtures that include a multiwell plate and a removable lid, wherein: (a) the multiwell plate has a plurality of sample wells, wherein each sample well comprises a sidewall and a bottom surface, wherein the bottom surface is joined to the sidewall by a rounded surface; and (b) the removable lid has a bottom surface that defines a planar expanse sufficient to cover the sample wells, which lid comprises a plurality of gas outlet ports that are positioned such that two or more of the sample wells are each in unimpeded fluid communication with an associated gas outlet port when the lid is positioned on the multiwell plate; wherein when the lid is attached to the multiwell plate and the gas outlet ports are blocked, no gas can flow into or out of the sample wells. The fixtures can further include one or more seals disposed between the multiwell plate and the lid, which seals allow gas flow between a sample well and an associated gas outlet port but prevent gas flow between sample wells and between a sample well and a non-associated gas outlet port. In some embodiments, the lids have a plurality of recessed areas which have a cross-sectional shape that corresponds to the cross-sectional shape of the sample wells, and the positions of which spatially correspond to the sample wells when the lid is placed on the multiwell plate.

[0014] The invention also provides a high throughput ball milling apparatus. This apparatus typically includes: (a) a rotary platform which rotates about a first axis, (b) a plurality of receptacles that are rotatably supported on the rotary platform, wherein each receptacle rotates about an axis that is substantially parallel to the first axis and is configured to hold at least one multiwell ball milling fixture; and (c) a motor in drive relation to the rotary platform that provides rotational forces thereto. Each receptacle can hold at least one multiwell ball milling fixtures, and in many embodiments can hold two or more plates. The apparatus also has a motor or other means for driving rotation of the receptacles. The rotating platform and the receptacles can rotate at the same speed, or at different speeds. The apparatus can have one motor that provides rotational force to both the receptacles and to the rotary platform, or can have two different motors.

[0015] Also provided by the invention are gas storage assay caps for a multiwell plate. The assay cap has a bottom surface and a top surface and includes: (a) a plurality of gas outlet ports that each have a first opening on the bottom surface and a second opening in a second surface of the cap, wherein the first openings of the gas outlet ports are spatially arranged such that each gas outlet port is in fluid communication with a sample well of a multiwell plate when the assay cap is positioned either (i) on a multiwell plate, or (ii) on a lid for a multiwell plate, which lid comprises a plurality of gas outlet ports that are in fluid communication with a sample well of a multiwell plate when the lid is positioned on a multiwell plate; and (b) a pressure sensor in fluid communication with the second opening of each of at least one of the gas outlet ports. Typically, each of the gas outlet ports is in fluid communication with a pressure sensor.

[0016] In some embodiments, gas storage assay cap is attached to a multiwell plate lid that has a bottom surface and a top surface and defines a planar expanse sufficient to cover sample wells of a multiwell plate. The lid has a plurality of gas outlet ports that each have a first opening on the bottom surface of the lid and a second opening in the top surface of the lid, wherein the first openings of the gas outlet ports are spatially arranged such that each gas outlet port is in fluid communication with a sample well of a multiwell plate when the assay cap is positioned on a multiwell plate, and the second openings are spatially arranged such that each gas outlet port in the lid is in fluid communication with a conduit in the assay cap. In some embodiments, the first opening of a gas outlet port in the multiwell plate lid is positioned in a recessed area that spatially corresponds to the sample wells when the lid is placed on a multiwell plate. The second openings of the gas outlet ports are in fluid communication with (a) a gas source, and (b) a vacuum source.

[0017] The invention also provides a high throughput gas storage assay device. These devices include: (a) a multiwell plate that has a plurality of sample wells; (b) a lid defining a planar expanse sufficient to cover the sample wells, which lid has a plurality of gas outlet ports, wherein the gas outlet ports are positioned such that two or more of the sample wells are each in fluid communication with an associated gas outlet port when the lid is positioned on the multiwell plate; and (c) a gas storage assay cap that comprises a top surface and a bottom surface that defines a planar expanse sufficient to cover the gas outlet ports of the multiwell plate lid when the assay cap is positioned on the lid, wherein the assay cap comprises a plurality of gas conduits that are positioned such that at least one conduit in the cap is in fluid communication an associated gas outlet port in the multiwell plate lid.

[0018] In some embodiments, the gas storage assay device has a pressure sensor in fluid communication with each of the gas conduits. The device also can have a vacuum source and a test gas source, both of which are in fluid communication with the gas conduits of the assay cap. One or more valves that regulate gas flow between the conduits and the vacuum source, and one or more valves that regulate gas flow between the gas conduits and the test gas source can also be included in the gas storage assay device. A single valve can be used for switching between the test gas source, the vacuum source, and the pressure sensor being in fluid communication with the gas conduit.

[0019] The gas storage assay device can also include a controller that comprises logic instructions that direct the device to perform a method that comprises the following steps:

[0020] (a) open a valve between the vacuum source and the gas conduit, thereby applying a vacuum to a sample well;

[0021] (b) close the valve between the vacuum source and the gas conduit;

[0022] (c) open a valve between the test gas source and the gas conduit, thereby allowing a test gas to flow into the sample well; and

[0023] (d) close the valve between the test gas source and the gas conduit.

[0024] In some embodiments, the multiwell plate lid that is used in the gas storage assay device has a bottom surface

that defines a planar expanse sufficient to cover sample wells of a multiwell plate and further includes a plurality of gas outlet ports that each comprise: i) a first opening on the bottom surface of the lid that is spatially positioned such that when the lid is positioned on a multiwell plate, the first opening is in fluid communication with a sample well; ii) a second opening in the top surface of the lid; and iii) a valve that regulates gas flow through the gas outlet port. These devices can further include a controller that includes logic instructions that direct the device to perform a method that has the following steps:

[0025] (a) open the valve that regulates gas flow through the outlet port and the valve between the vacuum source and the gas conduit, thereby applying a vacuum to a sample well;

[0026] (b) close the valve that regulates gas flow through the outlet port;

[0027] (c) close the valve between the vacuum source and the gas conduit;

[0028] (d) open the valve that regulates gas flow through the outlet port and the valve between the test gas source and the gas conduit, thereby allowing a test gas to flow into the sample well; and

[0029] (e) close the valve that regulates gas flow through the outlet port and the valve between the test gas source and the gas conduit.

[0030] Also provided by the inventions are methods for obtaining a plurality of alloys. These methods involve:

[0031] (a) dispensing a plurality of mixtures of precursor substances into sample wells of a multiwell plate;

[0032] (b) dispensing grinding balls into the sample wells; and

[0033] (c) subjecting the multiwell plate to a ball milling operation to form a plurality of alloys in an ultrafine powder form.

[0034] The invention also provides libraries of alloys in ultrafine powder form, wherein the library comprises at least 10 different alloys. In some embodiments, each of the members of the library is contained in a single multiwell plate. In some embodiments, the alloys of the library are formed by milling of a mixture of two or more precursor substances, wherein at least one of the precursor substances is a metal element. For example, in some embodiments at least one of the precursor substances is an element that can form a compound with hydrogen.

#### DESCRIPTION OF THE DRAWINGS

[0035] FIG. 1A shows a top view of a multiwell plate 20, FIG. 1B shows a cross-sectional view of the multiwell plate, and FIG. 1C shows an enlargement of the cross-sectional view.

[0036] FIGS. 2A and 2B show cross-sectional views of a multiwell plate 20 with an attached lid 30.

[0037] FIGS. 3A and 3B show cross-sectional views of a multiwell plate 20, attached lid 30, and cap 100.

[0038] FIG. 4 shows a schematic diagram of an apparatus for dispensing materials into individual wells 70 of the multiwell plates 20 in a combinatorial manner.

[0039] FIG. 5 shows a device for dispensing balls into individual wells of a multiwell plate 20.

[0040] FIG. 6 shows a top view of a rotary platform 300 to which are attached ten rotating receptacles 200.

[0041] FIG. 7 shows a partial side view of a high-throughput ball milling apparatus of the invention.

[0042] FIG. 8 shows a schematic of a high-throughput gas storage assay device.

[0043] FIG. 9 shows a schematic of milling balls and powdered metal slurries being dispensed into a multiwell plate. This step may be performed in open air as shown.

[0044] FIG. 10A shows a top view and FIG. 10B shows a side view of a multiwell plate lid that has spool valves to regulate gas flow through the gas outlet ports.

[0045] FIGS. 11A and 11B show a multiwell plate and an attached lid that has spool valves that regulate the flow of gas through the gas conduits.

[0046] FIG. 12 shows a multiwell ball milling fixture that includes a multiwell plate, a lid and a charging cap. The valves in the lid are in the open position, and a vacuum is applied to the system thereby drawing gas from the sample wells of the multiwell plate. The multiwell plate is shown being heated to facilitate evaporation of the solvent.

[0047] FIG. 13 shows a schematic of a milling gas being introduced into the sample wells after the vacuum has removed gas from the sample wells. The valves in the multiwell plate lid are opened to allow the milling gas to flow from the milling gas source to the sample wells. The fixture can be cooled to facilitate increasing the density of the milling gas.

[0048] FIG. 14 shows a schematic of the valves in the multiwell plate lid being closed to seal the multiwell plates. The desired milling gas is contained within the sample wells.

[0049] FIG. 15 shows a schematic of three ball milling fixtures stacked in preparation for ball milling. The sample wells contain the dried milling balls and the materials to be ball milled.

[0050] FIG. 16 shows a schematic of a ball-milled material being prepared for gas storage assay.

[0051] FIG. 17 shows the dispensing of milling balls in open air, after which powdered metal slurries are dispensed in an inert atmosphere glovebox.

[0052] FIG. 18 shows the attachment of a pierceable membrane and a membrane cap plate in a glovebox.

[0053] FIG. 19 shows four multiwell plates, each covered with the pierceable membrane and the membrane cap plate, stacked for ball milling.

[0054] FIG. 20 shows an assay cap plate attached to the multiwell ball milling fixture, prior to the cannulae piercing the membrane to allow gas flow to and from the sample wells. The interstitial space is charged with the test gas.

[0055] FIG. 21 shows the pierceable membrane being pierced by the cannulae, after which the sample wells are charged with test gas. The pressure is monitored to detect hydrogen absorption.

## DETAILED DESCRIPTION

[0056] The present invention provides an apparatus for simultaneously producing multiple alloys that consist of ultra-fine powder particles. Also provided are apparatus and methods for assaying alloys to identify those that have desired gas storage properties. The apparatus and methods are useful for, for example, creating and identifying alloys that are capable of storing gases such as hydrogen.

## Alloying/Assaying Fixture

[0057] In a first embodiment, the invention provides a fixture that can be used both for high-throughput ball milling and for assaying alloys that are produced through the ball milling process. The fixture includes a multiwell plate, a multiwell plate lid, and a cap. FIGS. 1A and 1B show a top view and a cross-sectional view, respectively, of one embodiment of a suitable multiwell plate 20. The multiwell plate typically is a planar structure having a top, a bottom and a plurality of sample wells 70. Each of the sample wells has one or more sidewalls and a bottom wall. Although schematically depicted in, e.g., FIG. 1 as having a substantially cylindrical shape (i.e., a circular cross-section), sample wells can have other cross-sectional shapes. To illustrate, at least a segment of a sample well can have a cross-sectional shape independently selected from, e.g., a regular n-sided polygon, an irregular n-sided polygon, a triangle, a square, a rounded square, a rectangle, a rounded rectangle, a trapezoid, a circle, an oval, or the like. Rounded internal reaction well surfaces are generally preferred to reduce undesirable accumulation of materials that can occur at angled internal wall surfaces. Rounded surfaces typically join the side-wall(s) to the bottom wall, thereby forming a concave sample well bottom 25 as illustrated in FIG. 1B.

[0058] The lid defines a planar expanse that is of sufficient size to cover the sample wells when the lid is placed on the multiwell plate. A suitable lid 30 is illustrated in FIGS. 2A and 2B. The lid has a bottom surface that, in some embodiments, has a plurality of recessed areas 60 that generally have shapes corresponding to inner cross-sectional shapes of the sample wells 70 of the multiwell plates 20. Each of these recessed areas, in some embodiments, has a diameter equal to that of the sample wells. The recessed areas are arrayed on the bottom surface such that each recessed area is aligned with a sample well when the lid is placed on the multiwell plate. In some embodiments, the recessed areas have a concave radius of curvature that is similar to, or identical to, that of the bottom of the sample wells of the multiwell plate. This prevents packing of powders into cracks during the ball milling process. The lid is, in some embodiments, removable from the multiwell plate to facilitate loading and unloading of the sample wells.

[0059] The lids have a plurality of gas outlet ports 40 that allow gas flow into and out of each sample well when the lid is positioned on the multiwell plate. The gas outlet ports each typically include: i) a first opening on the bottom surface of the lid that is spatially positioned such that when the lid is positioned on the multiwell plate, the first opening is in fluid communication with a sample well; ii) a second opening in the top surface of the lid. The first opening can be positioned in the recessed areas on the bottom surface of the lid, if such recessed areas are present. Attachment of the lid to multiwell plate, in some embodiments, places the gas outlet ports in unimpeded fluid communication with the

sample wells. By “unimpeded” is meant that no filter or membrane is interposed between the multiwell plate and the lid.

[0060] For some applications, it is desirable to conduct the ball milling and/or assaying operations in a vacuum or in a gas other than air. For example, it is sometimes desired to perform the ball milling and assaying in an inert or reducing atmosphere. Sometimes, an exceptionally pure atmosphere is desired for the ball milling or assaying. To facilitate these applications, the invention provides lids that have a valve that regulates flow through the gas outlet ports. Suitable valves include, for example, spool valves, rotary valves, ball valves, gate valves, butterfly valves, globe valves, needle valves, pintle valves, sleeve valves, and other types of valves known to those of skill in the art. In some embodiments, a plurality of valves are operably connected to each other, such that when a first valve is changed from an closed position to an open position, one or more additional valves are also changed from the closed position to the open position. FIGS. 10A and 10B show one example of a lid having such valves that regulate gas flow through the gas outlet ports. In particular, these figures show a lid having a spool valve that has a plurality of valve elements, one disposed in each gas outlet port. Movement of the spool valve in a first direction positions the valve elements in the open position (FIG. 11A) and movement of the spool valve in a second direction positions the valve elements in the closed position (FIG. 11B). As shown in this particular example, ten spool valves are inserted into ten bores that run through the lid perpendicular to the outlet ports. Each spool valve, in this particular example, consists of ten individual valve elements along its length. By sliding all ten spool valves a short distance in either direction, all 100 gas outlet ports can be opened or closed. The number of spool valves is typically equal to the number of rows or columns of sample wells in the multiwell plate to which the lid is to be attached. The valves can include seals, gaskets, or the like, or can be sealed simply by close tolerance of the valve fitting into the lid.

[0061] As shown in FIGS. 3A and 3B, the alloying/assay fixtures 120 also typically include a charging cap 100 that is positioned on the lid 30. The charging cap generally has a gas portal and a bottom surface that defines a planar expanse sufficient to cover each of the plurality of second openings of the gas outlet ports when the cap is positioned on the lid, thereby preventing gas flow into or out of the sample well via the gas outlet ports 40. The charging cap generally includes an air passage in fluid communication with each of the second openings of the gas outlet ports of the lid, and with a gas portal. This air passage can be, for example, a manifold or a recessed area that provides a passage for air or other gas to flow through the gas outlet ports of the lid to the gas portal. In some embodiments, the gas portal is connected to a vacuum source. Optionally, the gas portal can be connected to a source of a gas that is desired for ball milling. For example, the ball milling gas can be a reducing or inert atmosphere, or an atmosphere that is of particularly high purity. One or more valves is typically used to regulate flow to and from the vacuum source and the ball milling gas source. In some embodiments, a three-way valve is used to place either the vacuum source or the ball milling gas source in fluid communication with the gas portal, or to block gas

flow to and from the gas portal. In other embodiments, a separate valve is used for the vacuum source and for the test gas source.

[0062] In some situations, it is necessary that the sample materials to be ball milled may never be allowed to contact oxygen. In this case, the initial dispensing into wells is preferably performed in a glove box environment. The balls can be dispensed in open air, and the multiwell fixture is then moved through an airlock to the inert atmosphere of a glove box. The powders are dispensed in a slurry of organic solvent (FIG. 17). If ball milling is to be done with dry powders, the open fixture is left in the glove box until the solvents evaporate. This can be hastened with the addition of slight heating. If ball milling is to be done wet, one can immediately proceed to the next (capping) step.

[0063] While still in the glove box, a cap late is attached that contains a thin, pierce-able membrane layer situated such that it interrupts the flow path of the individual gas ports (FIG. 18). The fixture can now be removed from the glove box and stacked in the high throughput centrifugal ball mill for the ball milling process (FIG. 19).

[0064] After ball milling, an assay cap assembly is attached to the top of each fixture (FIG. 20). This assay cap consists of two plates with an array of cannulae. The cannulae are, in some embodiments, slidably moveable. Each cannulae has a fluid connection to the same assay system as described previously. The top plate connects each cannulae to its corresponding leg of the assay system. The bottom plate seals to the top of the well fixture with face sealing o-rings. In addition, each cannulae is sealed to its pilot hole in the bottom plate with a radial squeezed o-ring but is still free to slide axially. Before the cannulae are moved downward to pierce the membrane and come into gaseous communication with its corresponding well, the oxygen in the interstitial space between the well fixture and assay cap bottom plate is preferably eliminated. To do this, it is simply a matter of opening all of the vacuum valves to evacuate the space, followed by charging the space with test gas. These two operations can be repeated multiple times to ensure that all remaining vestiges of oxygen are removed.

[0065] Once this is accomplished, the top assay cap plate can be moved downward until it contacts the bottom assay cap plate. All cannulae will pierce the membrane and come into fluid communication with its corresponding test well (FIG. 21). At this point the assay is run as described herein.

[0066] The components of the high-throughput ball milling fixture are composed of any suitable material that can maintain the structural integrity of the fixture during the ball milling procedure. For example, one or more of the fixture components can be composed of metal, plastic, ceramic, or any suitable composite. Stainless steel is an example of a preferred material for the multiwell plate, lid, and caps of the high-throughput ball milling fixtures of the invention. In some embodiments, the sample wells are lined with a material such as stainless steel, carbon steel, tungsten carbide, ceramics, or other suitable materials known to those of skill in the art.

[0067] In some embodiments, it is desirable for the chambers where ball milling takes place have extremely high wear resistant properties. The use of a wear resistant surface can minimize or prevent premature wearing out of the

fixture and contamination of the sample with fixture material. To provide the desired wear resistance while keeping the overall mass of the fixture, thereby minimizing the required structural strength of the centrifuge that will ultimately ball mill the samples, thin shells of wear-resistant material can be fitted into pockets in a multiwell fixture plate, thereby forming a lining of the sample wells. Suitable materials for the linings include those with high wear resistance, and include, for example, highly alloyed steels, such as carbide tool steel. These materials are universally heavy, costly and difficult to machine. The entire well fixture plate and lid could be made of some such material, but the cost and mass of the fixture would become prohibitive. To avoid these problems, thin shells of wear resistant material ("mortar shells") are made that fit into pockets in a well fixture plate that is made of a lightweight material such as aluminum ("shell holder") (FIG. 22). O-rings in the lid plate, seal on the top surface of the Mortar Shells in an identical manner as a one-piece multiwell fixture plate. Thin shells of high alloy steel are ideally suited to manufacture by sintering. The lid plate could still be made of a wear resistant material, but as it much thinner than the well plate, the cost and mass penalty is not as serious. One could, however, use thin linings of wear-resistant material in the recessed areas of the lids in a manner analogous to the multiwell fixture plate.

[0068] The high-throughput ball milling fixture generally has one or more seals disposed between the multiwell plate and the lid. The seals allow gas to flow between a sample well and an associated gas outlet port in the lid, but prevent gas flow between sample wells and between a sample well and a non-associated gas outlet port. The seals can be, for example, O-rings 50 as shown in FIG. 2A. Similarly, the fixture typically includes one or more seals disposed between the lid and the cap, which seals prevent gas from flowing from one gas outlet port to another. The use of O-rings 110 as such seals is illustrated in FIG. 3A. In other embodiments, the seals are sheets of gasketing material that have perforations which correspond to the sample wells and/or to the conduit positions. Other suitable seals include gaskets, lip seals, cup seals, grommet seals, ring seals, and other types of seals known to those of skill in the art. Seals suitable for use in the devices of the present invention are optionally made from essentially any chemically resistant rubber or elastomeric material, many of which are well known in the art. For example, seals are optionally fabricated from, e.g., silicone rubber, Viton®, Santoprene®, Teflon®, Gore-Tex®, Celerus™, or the like. Many of these materials are readily available from various commercial suppliers, such as W.L. Gore & Associates (Newark, Del.). Combinations of materials, e.g., in the form of laminates are also optionally utilized as seals in the devices of the invention.

#### High-throughput Ball Milling Apparatus

[0069] The invention also provides a high-throughput ball milling apparatus that is configured for massively parallel ball milling operations. In some embodiments, the apparatus can simultaneously perform ball milling operations on hundreds or even thousands of different mixtures, yielding many different alloy mixtures that can then be tested to identify those that have desired properties.

[0070] The apparatus typically includes: (a) a rotary platform which rotates about a first axis; (b) a plurality of

receptacles that are rotatably supported on the rotary platform, wherein each receptacle rotates about an axis that is substantially parallel to the first axis and is configured to hold at least one multiwell ball milling fixture; and (c) a motor or other drive means that causes the rotary platform and the receptacles to rotate.

[0071] The high-throughput ball milling apparatus has, as illustrated in FIG. 6, at least one rotary platform 300 that rotates about a first axis. The rotary platform is typically supported on a main shaft. In some embodiments, the apparatus has two or more rotary platforms, each of which holds multiple receptacles for sample containers. Thus, the use of multiple rotary platforms allows a greater number of ball milling operations to be simultaneously performed. In some embodiments, the apparatus has two or more rotary platforms that are stacked one above the other, each supported by the same main shaft.

[0072] The apparatus generally has at least two, and preferably four or more receptacles, and in some embodiments ten or more receptacles for attaching multiwell ball milling fixtures to the rotary platform. The receptacles 200, as shown in FIG. 6, are rotatably supported on the rotary platform, generally near the outer perimeter of the rotary platform. Each receptacle can spin about its own axis, which axis is generally parallel to the axis of rotation of the rotary platform.

[0073] The receptacles, an embodiment of which is illustrated in FIG. 7, are each configured to hold at least one multiwell ball milling fixture 120, each of which typically includes a multiwell plate and a lid. The multiwell ball milling fixtures can also include a cap attached to the lid. In some embodiments, each receptacle can hold two or more, five or more, or even ten or more multiwell ball milling fixtures. FIG. 7 shows eleven multiwell ball milling fixtures attached to a single receptacle (the figure shows the multiwell plate and its associated lid as a single unit). The multiwell ball milling fixtures are typically attached to the receptacles so that the multiwell ball milling fixtures remain in place during rotation of the receptacles and/or the rotary platform. The multiwell ball milling fixtures are retained in position by fasteners such as clamping mechanisms, bolts, or other attachment means known to those of skill in the art. In the particular embodiment illustrated in FIG. 7, the ball milling fixtures are held in place by a retention plate 210 that is fastened to the rotating receptacle 200 by bolts 210 and nuts 220.

[0074] In some embodiments, the receptacles are configured to hold one or more alloying/assay fixtures such as those described herein. The use of these alloying/assay fixtures, including the multiwell plates with attached lids and caps, allows one to perform the ball milling and subsequent assaying in the same containers. This minimizes the manipulations that are required, as well as reducing losses due to transferring the powders from one container to another.

[0075] Massively parallel ball milling is accomplished by using multiple receptacles, each of which holds multiple sample containers, each of which in turn has multiple wells. For example, in some embodiments that high-throughput ball milling apparatus can have ten receptacles attached to a rotary platform, with each receptacle holding ten multiwell ball milling fixtures, each of which has 100 wells. This

particular apparatus therefore can simultaneously carry out ten thousand ball milling operations. Of course, these particular numbers of receptacles, multiwell ball milling fixtures, and sample wells per fixture are illustrative only and are not limiting.

[0076] The high-throughput ball milling apparatus of the invention also typically includes a motor or other means for driving the rotation of the rotary platform, and also for driving the rotation of the receptacles. Suitable motors are known to those of skill in the art and include, e.g., electric motors, internal combustion engines, turbines, hydraulic motors, and the like.

[0077] The motor or other drive means typically drives the rotation of the rotary platform through drive mechanisms such as gears, chains, belt drives, and the like. Speed changing devices can also be included. The rotating receptacles can be driven by one or more additional motors, or can be driven by the same motor as which drives rotation of the rotary platform. Again, gears, chains, belt drives, and the like, with or without speed changing devices, are suitable for transferring the motor force to the rotating receptacles. FIG. 7 illustrates an example of a drive mechanism for a rotating receptacle 200 which is attached to a rotating platform 300 by a shaft 330. Shown is one receptacle 200 for multiwell plates 20 that is attached to a rotary platform 300 by a shaft 330. A sprocket 310 is driven by a chain 320 that is connected to a sprocket on the motor. U.S. Pat. No. 6,126,097 includes a discussion of various configurations of drive mechanisms for ball milling apparatuses that are suitable for use in the high-throughput ball milling apparatus of the invention.

[0078] In some embodiments, the high-throughput ball milling apparatus is configured to allow the rotational speed of the rotary platform to be set independently of that of the receptacles. This permits the rotational speeds to be adjusted independently to optimize the ball milling process.

#### High-Throughput Ball Milling Process

[0079] The high-throughput ball milling apparatus of the invention can be used for preparing large numbers of alloys or other materials in a very fine powder form. The materials to be alloyed are deposited in sample wells of the multiwell plates. These materials are generally in micron- or millimeter-sized starting powders, which are reduced to nanometer-sized powders by the ball milling process. In some embodiments, combinations of different materials, and/or different amounts of materials are placed in each well. The materials can be arrayed in combinatorial fashion.

[0080] An example of an apparatus for dispensing powders in a combinatorial, high-throughput manner is shown in FIG. 4. This apparatus can be used to dispense mixtures of powders into the sample wells 70 of the high-throughput ball milling fixtures 20 described herein. The apparatus includes a dispensing head that includes one or more dispensing tips 350. Each dispensing tip is fluidly connected to a reservoir 360 that contains an element or other compound to be used as a precursor substance. The precursor compound is generally suspended in a liquid 390 and can be maintained in suspension by stirring using a motor-driven stirrer 370, if desired. A pump 380 can be used to transfer the precursor compounds to the dispensing tip. A multichannel pump connected to multiple reservoirs, each of which contains a

different precursor substance, can be used in conjunction with a controller that directs the amounts and particular combinations of precursor substances to be dispensed into each sample well.

[0081] Suitable precursor substances for mechanical alloying can include any element or compound. The precursor substances are typically provided in a particulate form to facilitate distribution into the sample wells. To obtain alloys that exhibit hydrogen storage capability, elements that can form a compound with hydrogen can be used as one of the precursor substances. Such elements include, for example, Li, Be, Mg, Ti, V, and Zr. Other suitable precursor substances for forming hydrogen-adsorbing alloys include, for example, C, B, Si, P, Zn, Ni, Fe, Cr, Cu, Al, Ca, Na, and K.

[0082] Grinding balls are also placed in the sample wells, either before or after the precursor substances are added to the wells. Grinding balls suitable for use in ball milling operations are known to those of skill in the art, and can be formed of materials such as stainless steel, carbon steel, tungsten carbide, ceramics, and the like. The diameter of the grinding balls is typically at least one mm, and often two mm or greater. The maximum grinding ball diameter is generally fifty mm, more typically about 10 mm. In some embodiments, the balls have a diameter of between about 2 and 5 mm.

[0083] An example of an apparatus that is useful for dispensing grinding balls **500** to wells of a multiwell plate **20** is shown in FIG. **5**. The grinding balls to be dispensed are placed in a reservoir **510** that has one or more openings **520** in the bottom surface. The opening is occluded by a round (cylindrical or spherical) rotating element **530** that has a recessed area **540**. When the rotating element is rotated so that the recessed area is aligned with the top of the opening in the bottom surface of the reservoir, the grinding balls fill the recessed area. The rotating element is then rotated so that the recessed area is aligned with the bottom of the opening, thereby dispensing the grinding balls into the sample wells. In some embodiments, the dispensing apparatus has multiple openings so that grinding balls can be dispensed simultaneously into multiple wells of a multiwell plate. In preferred embodiments, the dispensing apparatus has a number of openings that is equal to the number of rows or columns of wells of the multiwell plate, with the openings having a spatial position that corresponds to that of the spacing of the multiwell plate wells. In other embodiments, the dispensing apparatus has a number of openings that equals the number of wells of the multiwell plate, with the spatial distribution of the openings corresponding to that of the sample wells. In such embodiments in which the dispensing apparatus has multiple openings, the rotating elements can be one or more cylindrical elements that extend through the dispensing apparatus with an axis of rotation that is parallel to the plane of the bottom surface of the reservoir. These cylindrical elements have a plurality of recessed areas that correspond in number and position to the openings in a row or column.

[0084] Once the materials to be alloyed and the grinding balls are present in the sample wells, a lid is attached to the multiwell plate to seal the sample wells. If the lid has gas outlet ports, as described above for the lid of the alloying/assaying fixture of the invention, a cap is attached to the lid to seal the gas outlet ports.

[0085] If the materials are suspended in a liquid for dispensing into the sample wells, the liquid is preferably

evaporated from the wells prior to conducting the ball milling operation. It is possible, however, to perform the ball milling on wet samples if desired.

[0086] FIGS. **9-16** show an example of a process for preparing a sample for ball milling. FIG. **9** shows the dispensing of the grinding balls and the precursor substances into the multiwell plate. A multiwell plate lid that has valves to regulate gas flow through the gas conduits (FIG. **10**) is clamped on top of the now loaded multiwell plate and a charging cap plate is clamped on top of the lid. A charging cap plate that manifolds all gas outlet ports together into a single fluid communication is attached to the multiwell plate lid (FIG. **12**). The charging plate has a gas conduit that is attached, through one or more valves, to a vacuum source and optionally to a source of the gas desired for the ball milling process. With all spool valves shuttled in the open position, each sample well in the multiwell plate can communicate up through a gas outlet port of the lid and the gas conduit of the charging cap plate to the valves. As shown in FIG. **12**, the valves in the lid are placed in the open position, and a vacuum is applied to the system thereby drawing gas from the sample wells of the multiwell plate. The multiwell plate is can be heated to facilitate evaporation of the solvent, if present.

[0087] The valve to the vacuum source is then closed and the valve to the milling gas is opened (FIG. **13**). This will charge the wells with the desired gas. The fixture optionally can also be cooled to the desired milling temperature. If it is necessary to purge all vestiges of oxygen and nitrogen from the wells before processing, the vacuum and charging steps can be repeated multiple times to fully purge all undesired gas remnants.

[0088] When these steps are complete, the ten spool valves are shuttled into the closed position (FIG. **14**). This can seal each individual well absolutely gas tight, particularly when the valve includes O-rings or some other type of seal. The charging cap plate can now be removed. When all fixtures have been processed up to this point, they can now be stacked and ball milled as described below (FIG. **15**).

[0089] The multiwell plates with attached lids are then attached to a rotating receptacle of a high-throughput ball milling apparatus of the invention. The ball milling process is run for a sufficient time to achieve the desired average particle size. In typical embodiments, the rotating platform rotates at a speed of 50-500 rpm, more typically between about 50 and 100 rpm. The rotating receptacles can rotate at the same speed as the rotating platform, or at a different speed. For example, in some embodiments the receptacles rotate at a speed of between 20 and 500 rpm, more typically between about 50 and 100 rpm. Using the apparatus, one can obtain materials having an average particle size of less than 10  $\mu\text{m}$  in diameter, more preferably less one  $\mu\text{m}$  or less than 100 nm, and in some embodiments less than 10 nm in diameter. Materials that are in the form of powders having such particle sizes are sometimes referred to herein as being in an ultrafine powder form.

[0090] For certain applications, it is desirable to conduct the ball milling operation and/or other operations involving the resulting mechanical alloy in an inert atmosphere. The entire apparatus can be positioned in an airtight enclosure in which the atmosphere is composed of an inert gas. Alternatively, the atmosphere in the sample wells can be replaced



with the inert gas. Suitable inert gases that can be used include, for example, helium, neon, argon, krypton, xenon, and mixtures thereof.

#### High-throughput Gas Storage Assay Apparatus

[0091] The invention also provides devices for massively parallel assays of the gas storage capacity of various materials, such as alloys. This invention is useful, for example, to assay the hydrogen storage capacity of ultra-fine particles of materials such as metals, hydrides, and the like. The assay apparatus of the invention provides a means for conducting a large number of gas storage assays simultaneously, thereby making feasible the assay of combinatorial collections of materials in a high throughput manner.

[0092] The invention also provides a gas storage assay cap for a multiwell plate. The gas storage assay cap has a bottom surface and a second surface (e.g., the top surface or a side surface), as well as: (a) a plurality of gas conduits that each have a first opening on the bottom surface and a second opening in the second surface of the assay cap, wherein the first openings of the gas conduits are spatially arranged such that each gas conduit is in fluid communication with a sample well of a multiwell plate when the assay cap is attached to a component of a multiwell ball milling fixture selected from the group consisting of: (1) a multiwell plate that comprises a plurality of sample wells; and (2) a multiwell plate lid that is attached to a multiwell plate and comprises a plurality of gas outlet ports that are each in fluid communication with a sample well of the multiwell plate; and (b) a pressure sensor in fluid communication with the second opening of at least one of the gas conduits.

[0093] Illustrated in FIG. 8 is an embodiment in which the gas storage assay caps are configured to be placed on a lid 30 that in turn is placed on a multiwell plate 20. The assay caps have a planar expanse that is sufficient to cover the gas outlet ports 40 of the lid when the caps are placed on the lid. The gas conduits 410 of the assay cap are spatially positioned to be in fluid communication with corresponding gas outlet ports of the lid and therefore are also in fluid communication with a sample well 70 of a multiwell plate when the lid is positioned on the plate and the cap is positioned on the lid.

[0094] The gas storage assay caps of the invention also include a pressure sensor 450 in fluid communication with the second opening of each of at least one of the gas conduits. A tube or other conduit can be used to connect the pressure sensor to the second opening of the gas conduit. Typically, each gas conduit is in fluid communication with a pressure sensor. Suitable pressure sensors are known to those of ordinary skill in the art, and include, for example, pressure transducers (e.g., piezoelectric, capacitive, magnetic), mechanical gauges, and the like.

[0095] The gas conduits of the assay caps are in fluid communication with a test gas source. The gas source can be connected to the gas conduit by a tube or other connector 430, for example. In some embodiments, the gas source is connected to each of the gas conduits by means of a distribution manifold or the like. The test gas source contains the gas for which one desires to assay the storage capacity of a material that is contained in the multiwell plates. For example, the test gas source can contain hydrogen, oxygen, or any other gas of interest. A valve 500 that

is structured to regulate gas flow to and from the test gas source is operably connected to the test gas source. Suitable valves are known to those of skill in the art and include, for example, solenoid valves, gate valves, check valves, rotary valves, ball valves, butterfly valves, pintle valves, globe valves, needle valves, sleeve valves, and the like.

[0096] The gas conduits typically are also in fluid communication with a vacuum source. The vacuum source can be connected to the gas conduits by a tube or other connector, which connector can be the same as or different from the connector that connects the gas source to the gas conduits. The apparatus generally also includes a valve 510 that can turn on or off the application of a vacuum to the gas outlet ports. In some embodiments, a single valve switches between the test gas source, the vacuum source, and the pressure sensor being in fluid communication with the gas conduit. Although the drawings illustrate a single gas conduit providing fluid communication between a sample well and the test gas source, the vacuum source, and the pressure sensor, the gas storage assay caps of the invention can also have two or more gas conduits for each sample well. In these embodiments, the gas source, the vacuum source, and the pressure sensor can each be connected to an individual gas conduit if desired.

[0097] The invention also provides high throughput gas storage assay devices for conducting multiple assays of gas storage capacity. These devices include a multiwell plate, a lid, and an assay cap, such those that are described above. The materials to be assayed for gas storage capacity are placed in the sample wells of the multiwell plate.

[0098] Typically, one or more seals 420 are disposed between the lid and the assay cap (or between the multiwell plate and the assay cap, if the assay cap is positioned directly on the multiwell plate), which seals allow gas to flow between a sample well and an associated gas outlet port but prevent gas flow between two or more sample wells and between a sample well and a gas outlet port other than that which is associated with that sample well.

[0099] In some embodiments, the assay devices use the multiwell alloying/assay fixtures described above. The assay caps are attached to the alloying/assay fixtures for conducting the gas storage assay.

[0100] The gas storage assay devices of the invention can also include a controller that has logic instructions that direct the device to perform a gas storage assay. For example, the controller can include logic instructions that direct the device to perform a method that includes the following steps:

[0101] (a) open a valve between the vacuum source and the gas conduit, thereby applying a vacuum to a sample well;

[0102] (b) close the valve between the vacuum source and the gas conduit;

[0103] (c) open a valve between the test gas source and the gas conduit, thereby allowing a test gas to flow into the sample well; and

[0104] (d) close the valve between the test gas source and the gas conduit.

[0105] In some embodiments, the gas storage assay device includes a multiwell plate lid that has a bottom surface that

defines a planar expanse sufficient to cover sample wells of a multiwell plate and also has a plurality of gas outlet ports that each include: i) a first opening on the bottom surface of the lid that is spatially positioned such that when the lid is positioned on a multiwell plate, the first opening is in fluid communication with a sample well; ii) a second opening in the top surface of the lid; and iii) a valve that regulates gas flow through the gas outlet port. In these embodiments, the controller can include logic instructions that direct the device to perform a method that includes the following steps:

[0106] (a) open the valve that regulates gas flow through the outlet port and the valve between the vacuum source and the gas conduit, thereby applying a vacuum to a sample well;

[0107] (b) close the valve that regulates gas flow through the outlet port;

[0108] (c) close the valve between the vacuum source and the gas conduit;

[0109] (d) open the valve that regulates gas flow through the outlet port and the valve between the test gas source and the gas conduit, thereby allowing a test gas to flow into the sample well; and

[0110] (e) close the valve that regulates gas flow through the outlet port and the valve between the test gas source and the gas conduit.

#### High-Throughput Gas Storage Assay Methods

[0111] The invention also provides methods for conducting high-throughput assays of the gas storage capacity of materials. The methods are useful, for example, to assay the gas storage capacity of alloys that have been formed through use of the high-throughput ball milling apparatus described herein, although materials formed by other means can also be assayed for gas storage capacity using the high-throughput gas storage assay methods and devices of the invention.

[0112] If the materials to be assayed have been formed using the multiwell ball milling fixture described herein, any solvents that are present in the sample wells after the ball milling is removed by evaporation (after removing the cap, if attached). The ball milling fixture can be heated to facilitate the evaporation. It is not necessary to remove the powders from the ball milling fixture in some embodiments, as the other components of the gas storage assay devices are configured to attach to the same multiwell plate and lid as are used in the ball milling operation.

[0113] The assays are conducted using a gas storage assay device as described above. The assay cap is attached to the multiwell plate (which may or may not have an attached lid). A vacuum is applied to the sample wells, for example by opening a valve between the gas outlet ports and the vacuum source. The vacuum source evacuates each well and the associated gas outlet ports and conduits. The vacuum valve is then closed and the valve which regulates flow from the test gas source is opened, thereby allowing the test gas to flow into the sample wells. The test gas source valve is then closed, creating a static volume of test gas at a fixed pressure in each well. The gas pressure in each well is determined using the pressure sensors. In some embodiments, readings from the pressure sensors are automatically monitored over the time of the assay.

[0114] The methods are useful for determining various gas storage properties of the materials in the sample wells. A decrease in pressure in a particular well over time is a measure of the gas absorption capacity of the material in that well. Gas desorption can be assayed subsequently by raising the temperature of the sample and monitoring for an increase in gas pressure in a well. By performing the adsorption/desorption experiments at varying temperatures, one can determine the energy required to load and unload hydrogen or other gases from the alloys. The number of gas loading and unloading cycles that a particular material can undergo before loss of desirable properties can be determined by repeating the adsorption/desorption assay numerous times.

[0115] The use of the high throughput gas storage assay device allows many samples to be tested in a rapid automated manner. In some embodiments, ten or more samples are tested in a single experiment. For example, 100 or more, or 1,000 or more samples can be tested in a single experiment using the devices of the invention. In fact, hundreds of thousands or even millions of different materials can be assayed using the methods and devices of the invention. Computer algorithms for analyzing results of combinatorial studies can be used to analyze the results of the assays and facilitate the identification of an alloy having optimal gas storage properties. See, e.g., U.S. Pat. No. 6,826,549. Materials that exhibit promising gas storage properties can be subjected to further tests using other assays known to those of skill in the art.

[0116] While the foregoing invention has been described in some detail for purposes of clarity and understanding, it will be clear to one skilled in the art from a reading of this disclosure that various changes in form and detail can be made without departing from the true scope of the invention. For example, all the techniques and apparatus described above may be used in various combinations. All publications, patents, patent applications, or other documents cited in this application are incorporated by reference in their entirety for all purposes to the same extent as if each individual publication, patent, patent application, or other document were individually indicated to be incorporated by reference for all purposes.

1. A gas storage assay cap for a multiwell plate, which gas storage assay cap comprises a bottom surface and a second surface, wherein the assay cap further comprises:

(a) a plurality of gas conduits that each have a first opening on the bottom surface and a second opening in the second surface of the assay cap, wherein the first openings of the gas conduits are spatially arranged such that each gas conduit is in fluid communication with a sample well of a multiwell plate when the assay cap is attached to a component of a multiwell ball milling fixture selected from the group consisting of:

- (1) a multiwell plate that comprises a plurality of sample wells; and
- (2) a multiwell plate lid that is attached to a multiwell plate and comprises a plurality of gas outlet ports that are each in fluid communication with a sample well of the multiwell plate; and

(b) a pressure sensor in fluid communication with the second opening of at least one of the gas conduits.

**2.** The assay cap of claim 1, further comprising a multiwell plate lid that is attached to the bottom surface of the assay cap, wherein the multiwell plate lid comprises a top surface and a bottom surface that defines a planar expanse sufficient to cover sample wells of a multiwell plate, wherein the lid comprises a plurality of gas outlet ports that each have a first opening on the bottom surface of the lid and a second opening in the top surface of the lid, wherein the first openings of the gas outlet ports are spatially arranged such that each gas outlet port is in fluid communication with a sample well of a multiwell plate when the assay cap is positioned on a multiwell plate, and the second openings are spatially arranged such that each gas outlet port in the lid is in fluid communication with a gas conduit in the assay cap.

**3.** The assay cap of claim 1, wherein the second openings of the gas conduits are in fluid communication with (a) a gas source, and (b) a vacuum source.

**4.** The assay cap of claim 3, wherein the gas source is a hydrogen source.

**5.** The assay cap of claim 1, wherein the second openings of the gas conduits are located in the top surface.

**6.** The assay cap of claim 1, wherein each of the gas conduits is in fluid communication with a pressure sensor.

**7.** A high throughput gas storage assay device, the device comprising:

(a) a multiwell plate that comprises a plurality of sample wells;

(b) a multiwell plate lid that is attached to the multiwell plate and comprises a plurality of gas outlet ports that are in fluid communication with a sample well of the multiwell plate; and

(c) a gas storage assay cap that comprises a top surface and a bottom surface that defines a planar expanse sufficient to cover the gas outlet ports of the multiwell plate lid when the assay cap is positioned on the lid, wherein the assay cap comprises a plurality of gas conduits that are positioned such that at least one conduit in the cap is in fluid communication an associated gas outlet port in the multiwell plate lid.

**8.** The gas storage assay device of claim 7, wherein the device further comprises one or more seals disposed between the multiwell plate and the lid, and one or more seals disposed between the lid and the assay cap, which seals allow gas flow between a sample well and an associated conduit in the assay cap but prevent gas flow between sample wells and between a sample well and a non-associated conduit.

**9.** The gas storage assay device of claim 8, wherein the seals comprise a plurality of O-rings.

**10.** The gas storage assay device of claim 8, wherein the seal comprises a gasket that comprises an opening between at least one sample well and an associated conduit, which opening allows gas to flow between the sample well and the conduit.

**11.** The gas storage assay device of claim 7, wherein the device further comprises a pressure sensor in fluid communication with each of the gas conduits of the assay cap.

**12.** The gas storage assay device of claim 11, wherein the pressure sensor comprises a pressure transducer or a mechanical gauge.

**13.** The gas storage assay device of claim 7, wherein the device further comprises a vacuum source and a test gas

source, both of which are in fluid communication with the gas conduits of the assay cap.

**14.** The gas storage assay device of claim 7, wherein the multiwell plate comprises at least 10 sample wells and the lid and the assay cap comprises at least 10 gas conduits, each of which is in fluid communication with a sample well.

**15.** The gas storage assay device of claim 7, wherein the multiwell plate comprises at least 100 sample wells, the assay cap comprises at least 100 gas conduits, and the multiwell plate lid comprises at least 100 gas outlet ports, each of which is associated with a sample well.

**16.** The gas storage assay device of claim 13, wherein the device comprises a valve that regulates gas flow between the gas conduit and the vacuum source, and a valve that regulates gas flow between the gas conduit and the test gas source.

**17.** The gas storage assay device of claim 16, wherein the valve is a solenoid operated valve.

**18.** The gas storage assay device of claim 16, wherein a single valve switches between the test gas source, the vacuum source, and the pressure sensor being in fluid communication with the gas conduit.

**19.** The gas storage assay device of claim 16, wherein the device comprises a manifold that distributes gas between the test gas source and/or the vacuum source and the gas conduits.

**20.** The gas storage assay device of claim 16, wherein the test gas source contains hydrogen.

**21.** The gas storage assay device of claim 16, wherein the device further comprises a controller that comprises logic instructions that direct the device to perform a method that comprises the following steps:

(a) open a valve between the vacuum source and the gas conduit, thereby applying a vacuum to a sample well;

(b) close the valve between the vacuum source and the gas conduit;

(c) open a valve between the test gas source and the gas conduit, thereby allowing a test gas to flow into the sample well; and

(d) close the valve between the test gas source and the gas conduit.

**22.** The gas storage assay device of claim 13, wherein the multiwell plate lid comprises a bottom surface that defines a planar expanse sufficient to cover sample wells of a multiwell plate and comprises a plurality of gas outlet ports that each comprise: i) a first opening on the bottom surface of the lid that is spatially positioned such that when the lid is positioned on a multiwell plate, the first opening is in fluid communication with a sample well; ii) a second opening in the top surface of the lid; and iii) a valve that regulates gas flow through the gas outlet port.

**23.** The gas storage assay device of claim 22, wherein the device further comprises a controller that comprises logic instructions that direct the device to perform a method that comprises the following steps:

(a) open the valve that regulates gas flow through the outlet port and the valve between the vacuum source and the gas conduit, thereby applying a vacuum to a sample well;

- (b) close the valve that regulates gas flow through the outlet port;
- (c) close the valve between the vacuum source and the gas conduit;
- (d) open the valve that regulates gas flow through the outlet port and the valve between the test gas source

- and the gas conduit, thereby allowing a test gas to flow into the sample well; and
- (e) close the valve that regulates gas flow through the outlet port and the valve between the test gas source and the gas conduit.

\* \* \* \* \*