

(19) **United States**

(12) **Patent Application Publication**

Visco et al.

(10) **Pub. No.: US 2008/0057399 A1**

(43) **Pub. Date: Mar. 6, 2008**

(54) **IONICALLY CONDUCTIVE COMPOSITES FOR PROTECTION OF ACTIVE METAL ANODES**

(60) Provisional application No. 60/418,899, filed on Oct. 15, 2002.

(75) Inventors: **Steven J. Visco**, Berkeley, CA (US); **Yevgeniy S. Nimon**, Danville, CA (US); **Bruce D. Katz**, Berkeley, CA (US)

Publication Classification

(51) **Int. Cl.**
H01M 2/16 (2006.01)
(52) **U.S. Cl.** **429/246**

Correspondence Address:
BEYER WEAVER LLP
P.O. BOX 70250
OAKLAND, CA 94612-0250 (US)

(57) **ABSTRACT**

Disclosed are ionically conductive composites for protection of active metal anodes and methods for their fabrication. The composites may be incorporated in active metal negative electrode (anode) structures and battery cells. In accordance with the invention, the properties of different ionic conductors are combined in a composite material that has the desired properties of high overall ionic conductivity and chemical stability towards the anode, the cathode and ambient conditions encountered in battery manufacturing. The composite is capable of protecting an active metal anode from deleterious reaction with other battery components or ambient conditions while providing a high level of ionic conductivity to facilitate manufacture and/or enhance performance of a battery cell in which the composite is incorporated.

(73) Assignee: **PolyPlus Battery Company**

(21) Appl. No.: **11/823,847**

(22) Filed: **Jun. 27, 2007**

Related U.S. Application Data

(63) Continuation of application No. 10/686,189, filed on Oct. 14, 2003, now Pat. No. 7,282,296.

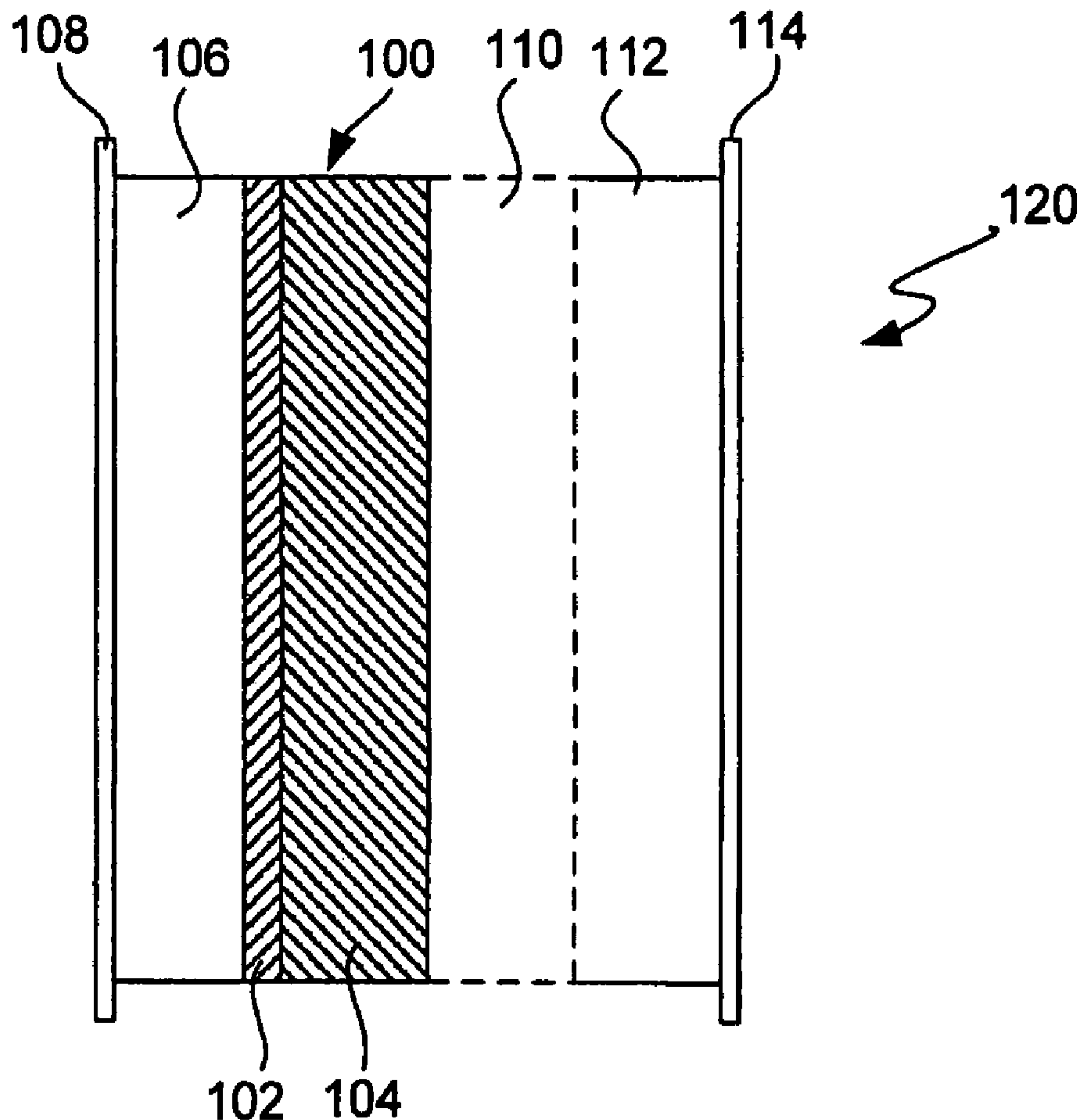

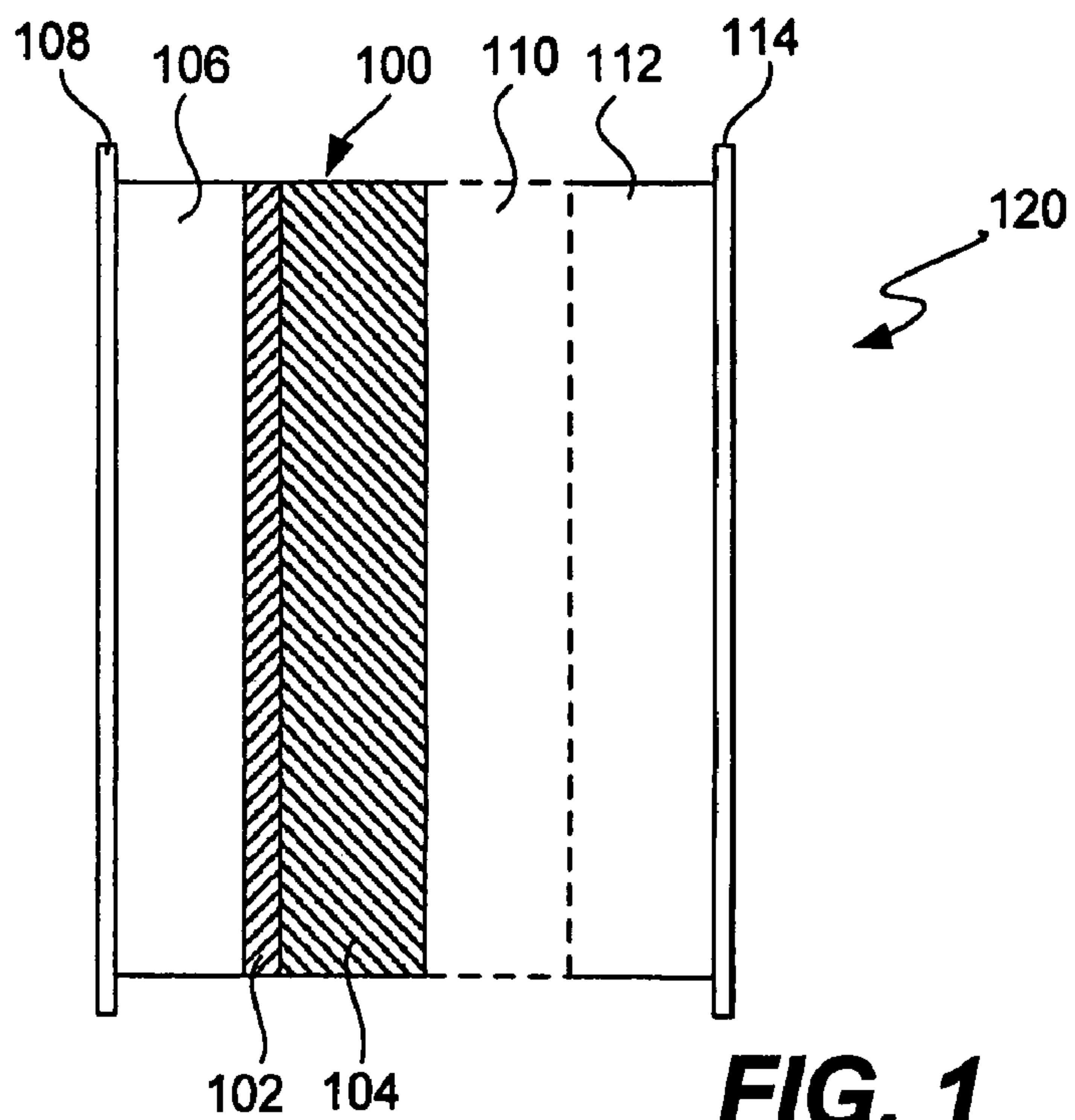

FIG. 1

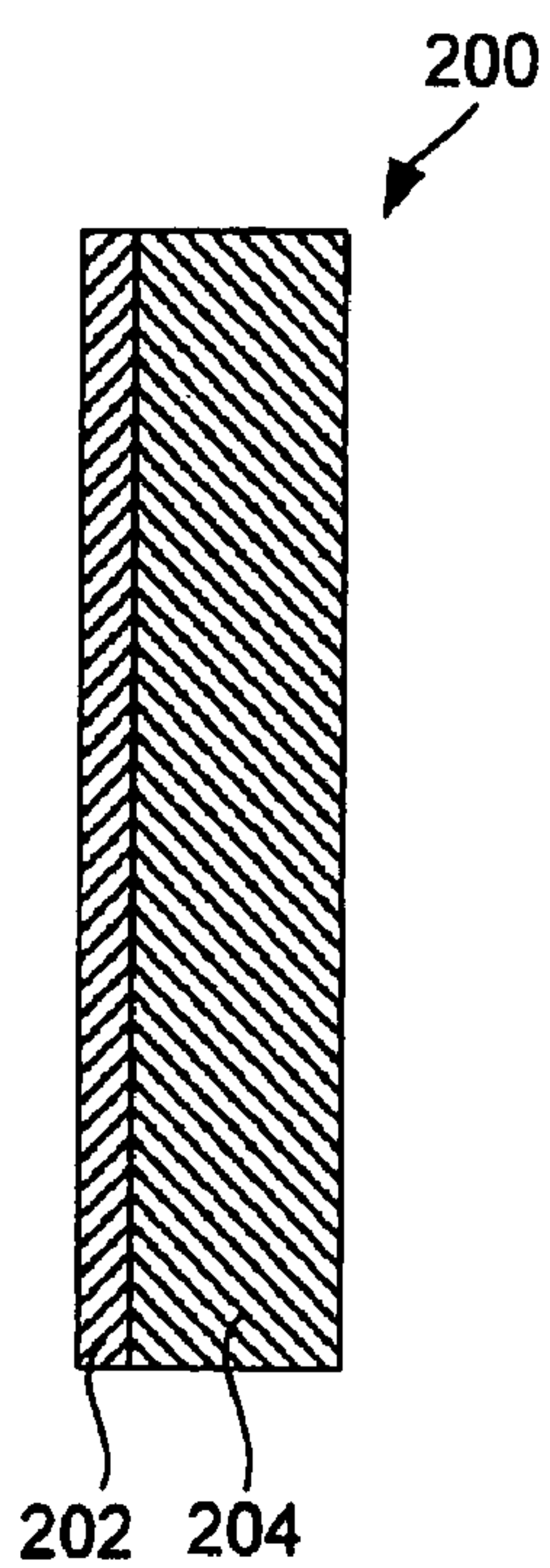

FIG. 2

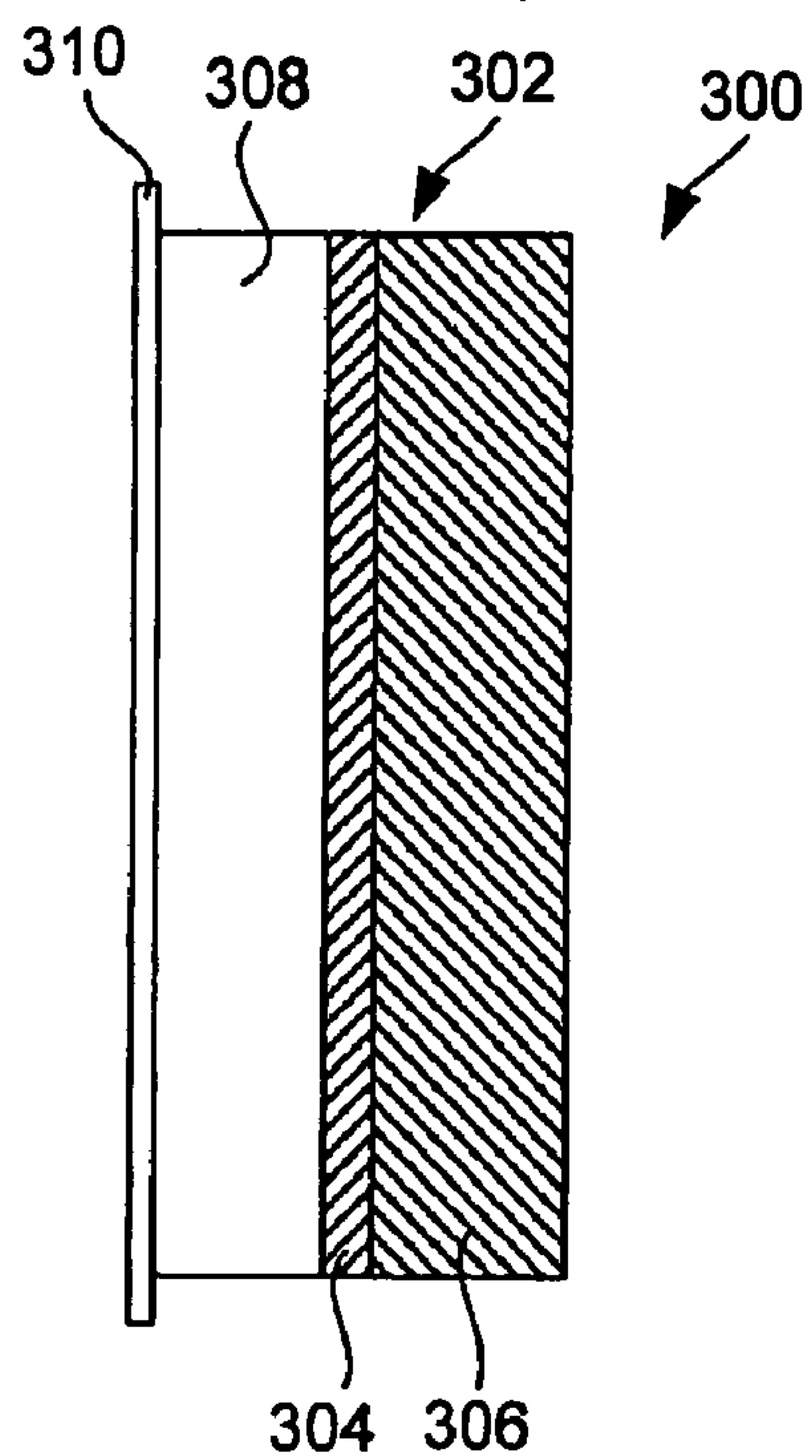

FIG. 3

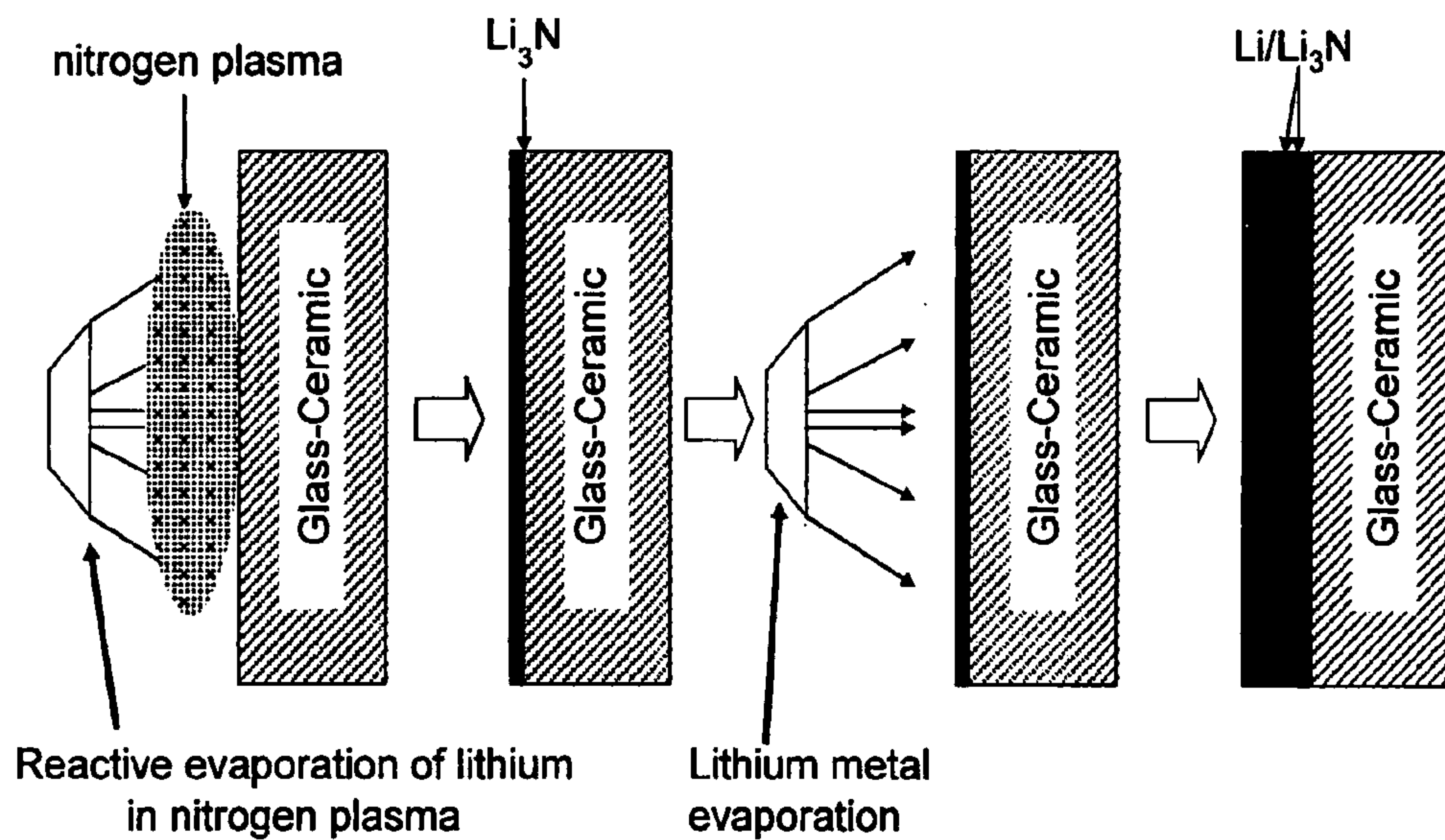

FIG. 4A

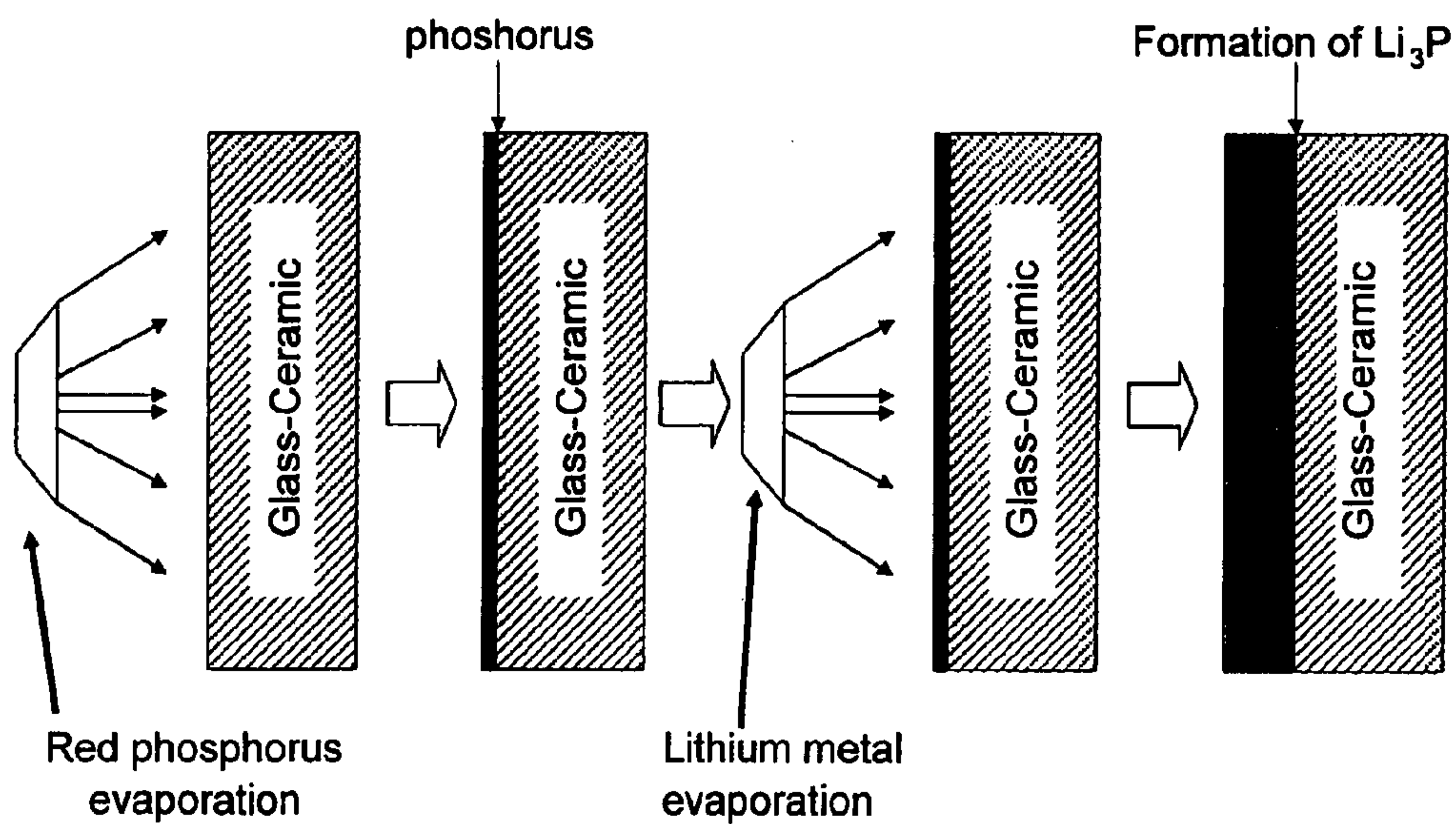

FIG. 4B

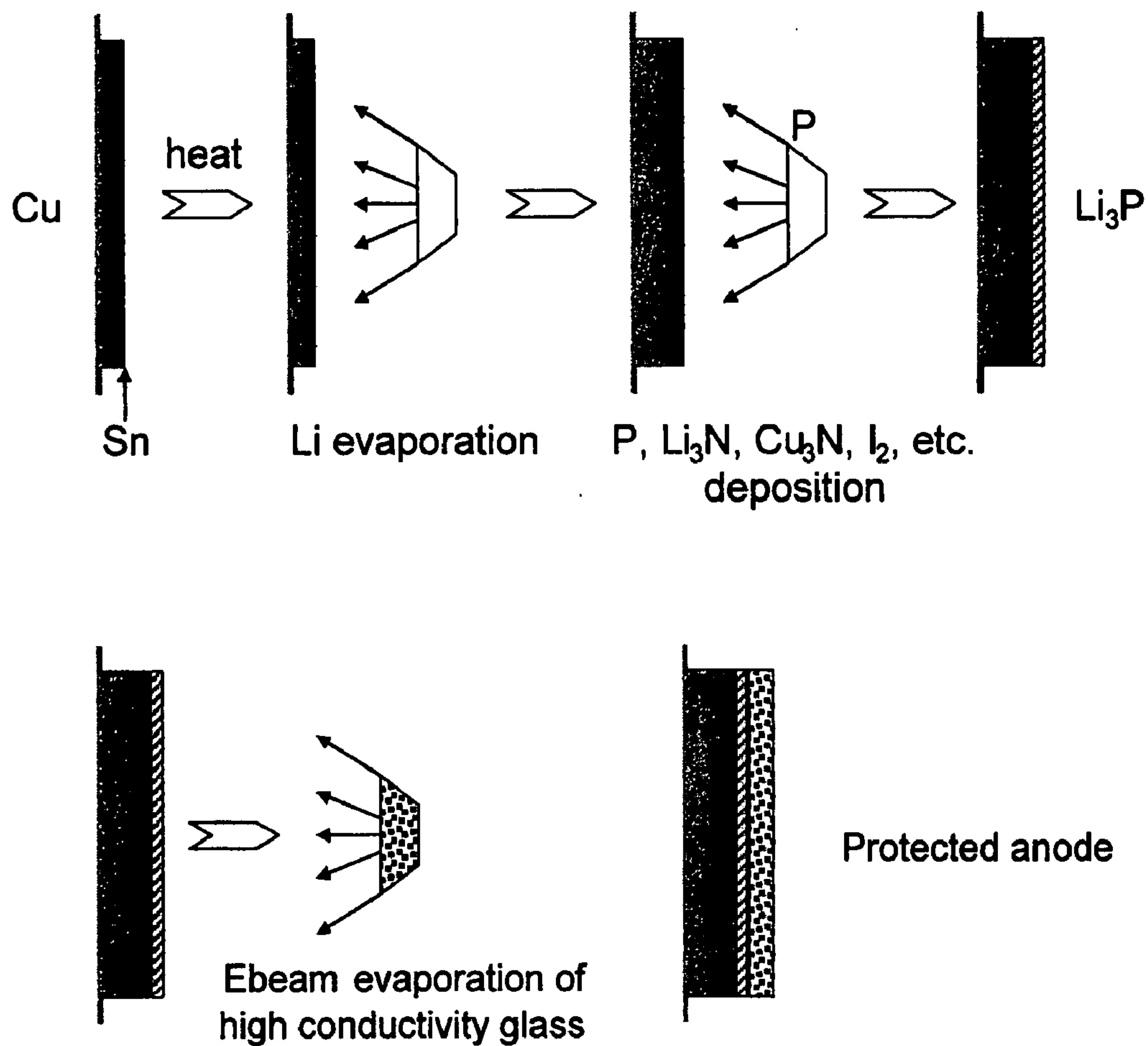

FIG. 5

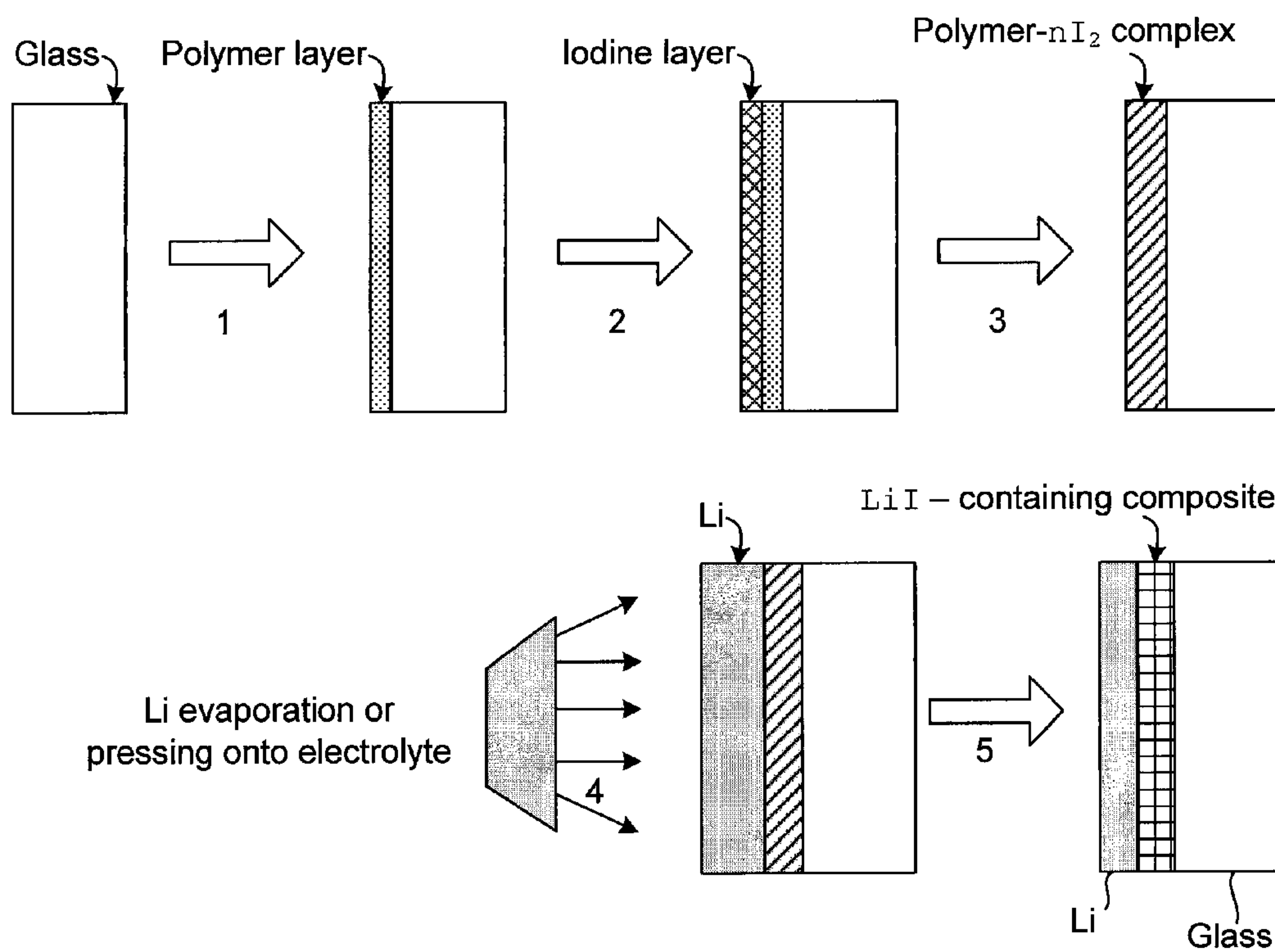

FIG. 6A

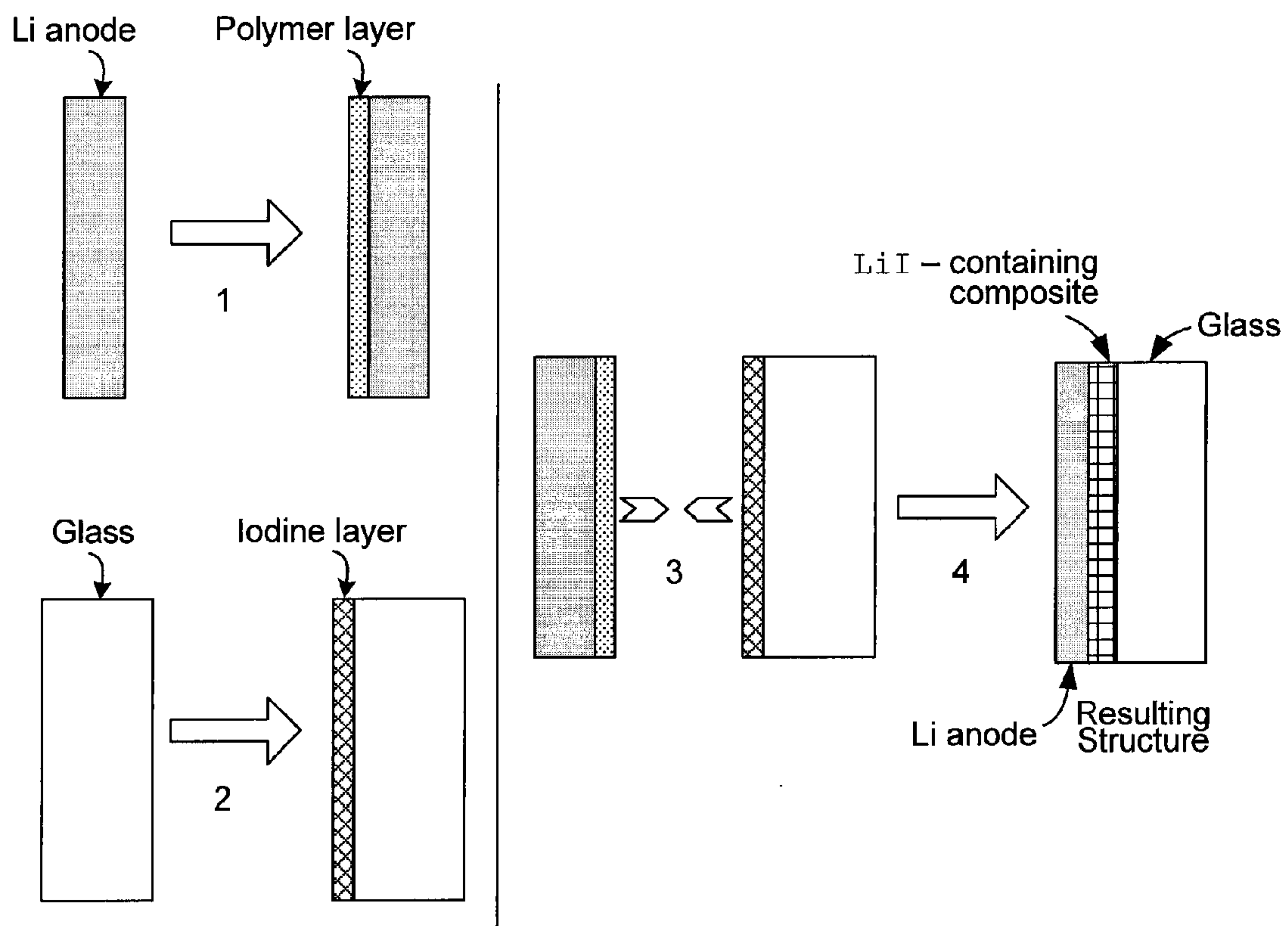

FIG. 6B

Impedance Plot for Solid-State Cell:
Li | LiPON | Cu

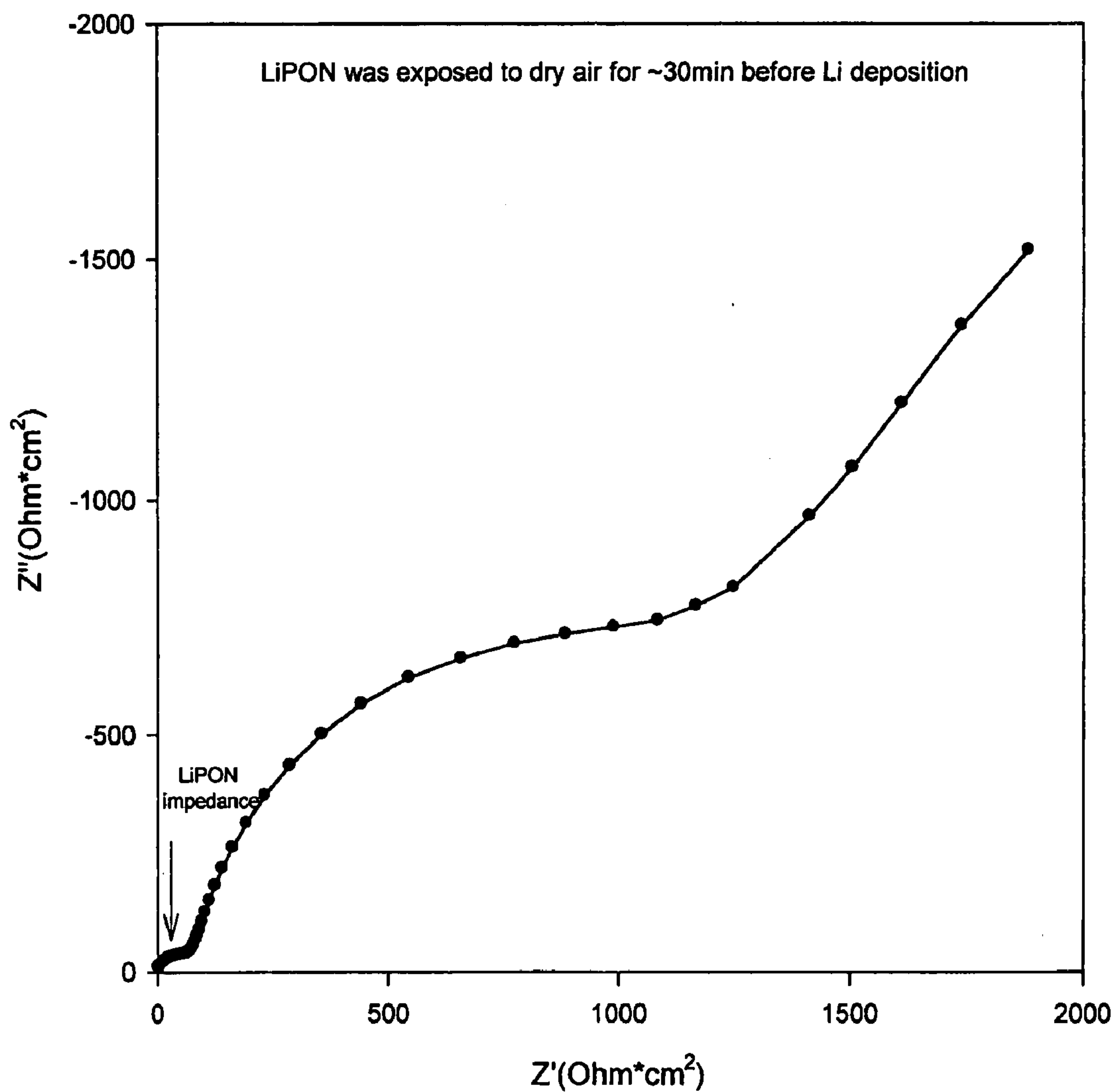

FIG. 7A

Impedance Plot for Solid-State Cell: Li | Cu₃N | LiPON | Cu
LiPON surface is protected with in situ formed Li₃N

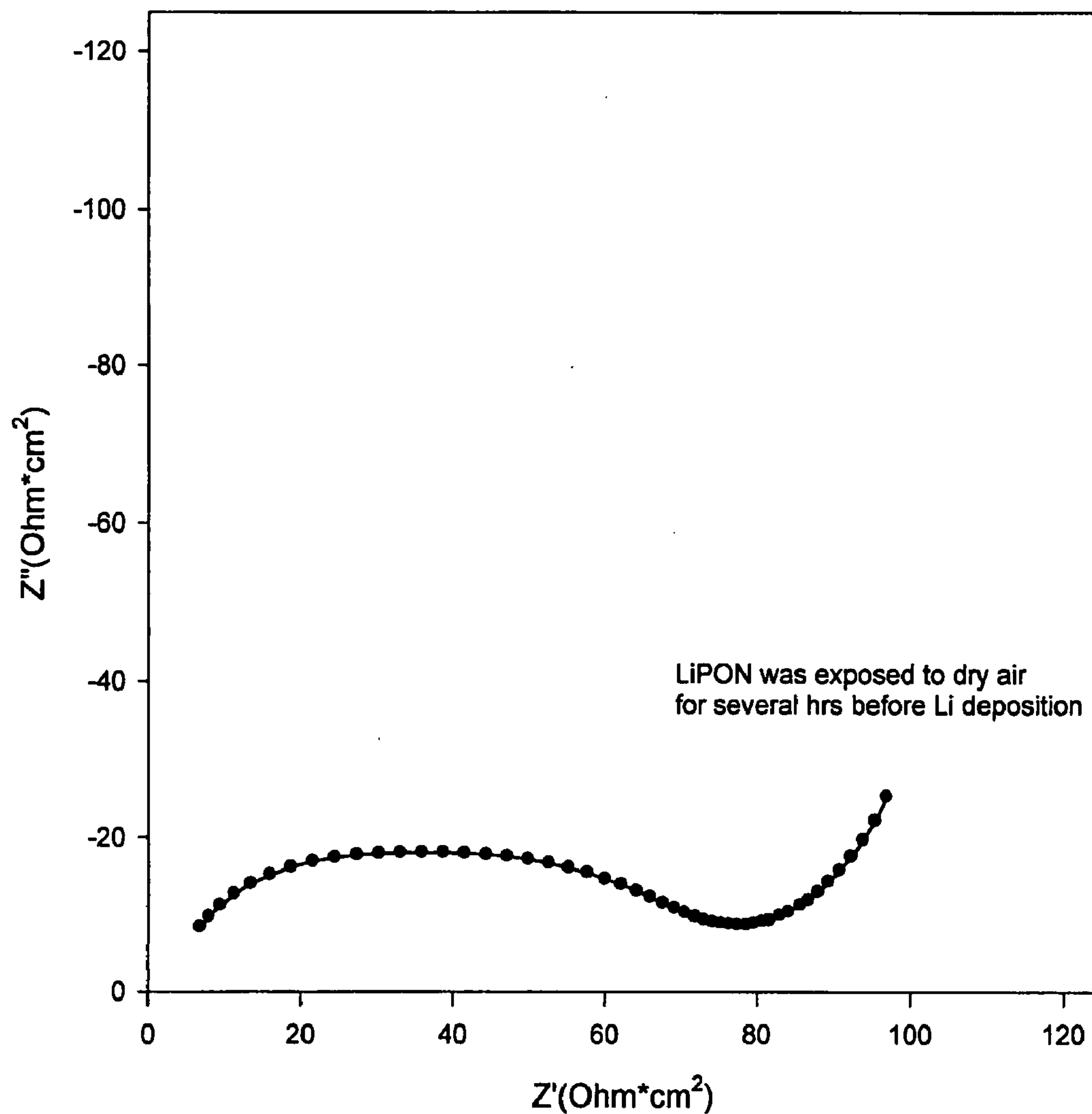

FIG. 7B

**Impedance Plot for Solid-State Cell:
Li | OHARA plate | Au**

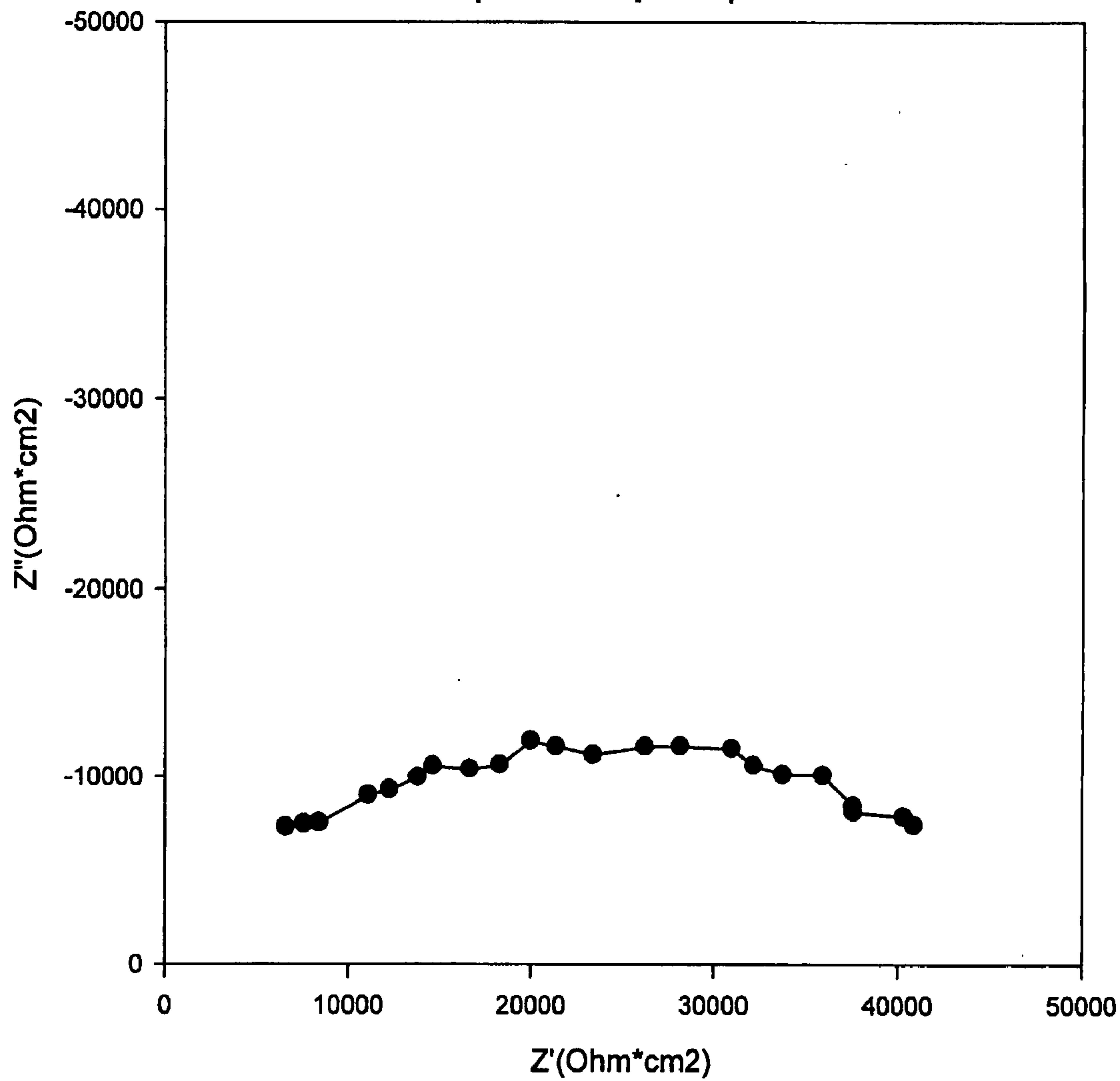

FIG. 8A

**Impedance Plot for Solid-State Cell:
Li | Cu₃N | OHARA plate | Au**

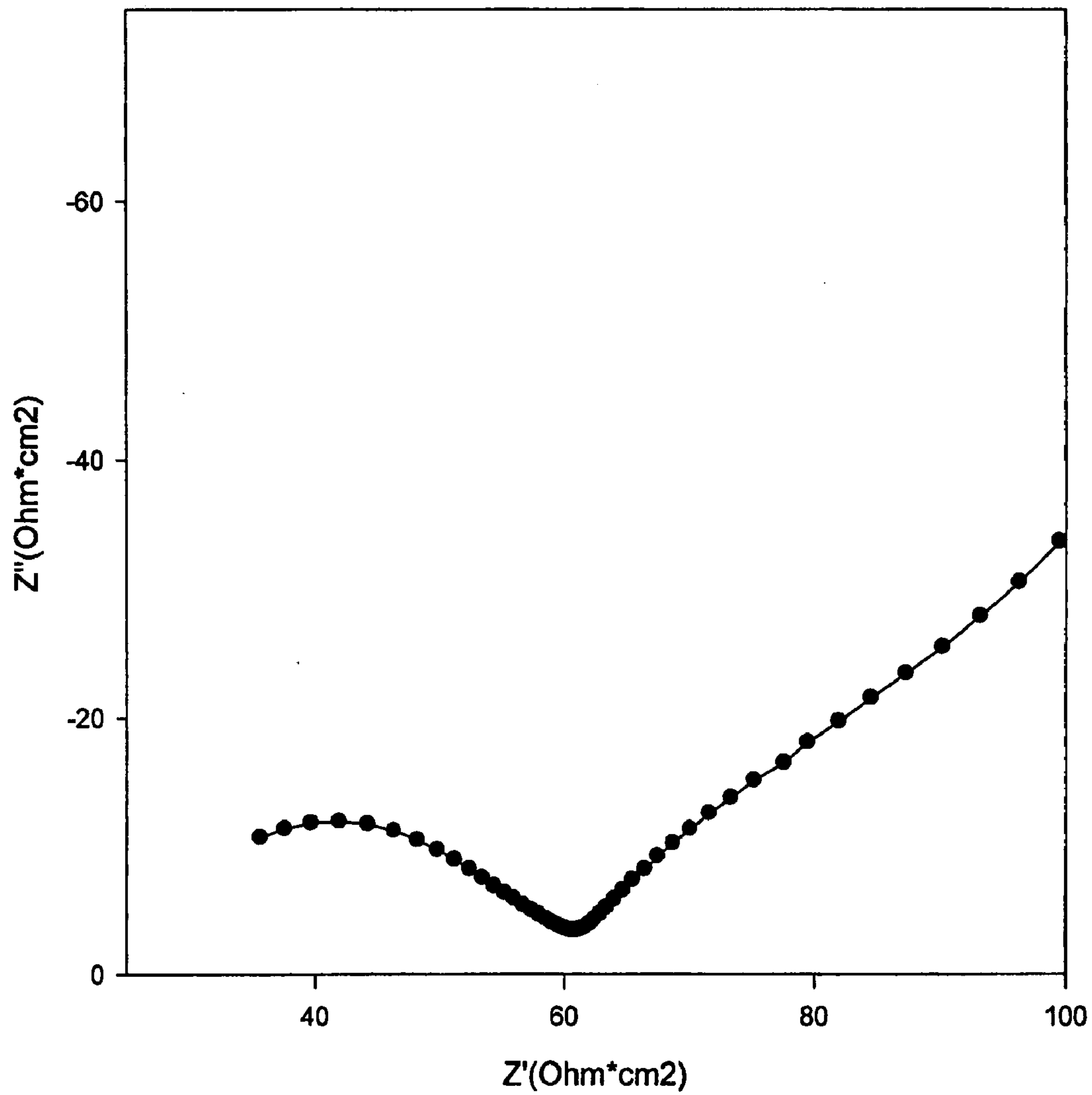

FIG. 8B

Impedance Plot for Cells Having Unprotected and Cu_3N -protected OHARA Material

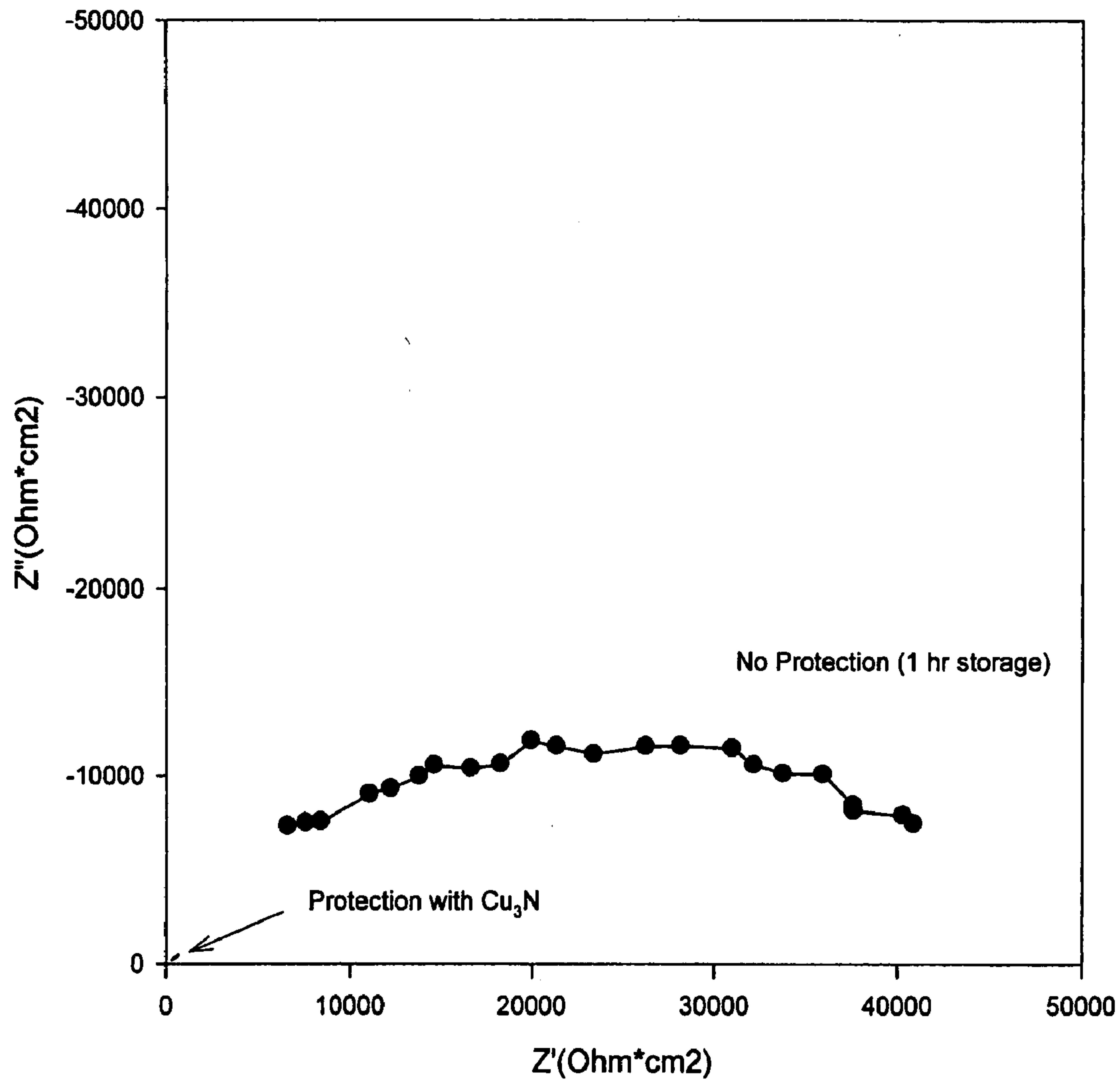

FIG. 8C

Cyclic Voltammetry for Solid State Cell:
 Li | Cu₃N | OHARA plate | Au

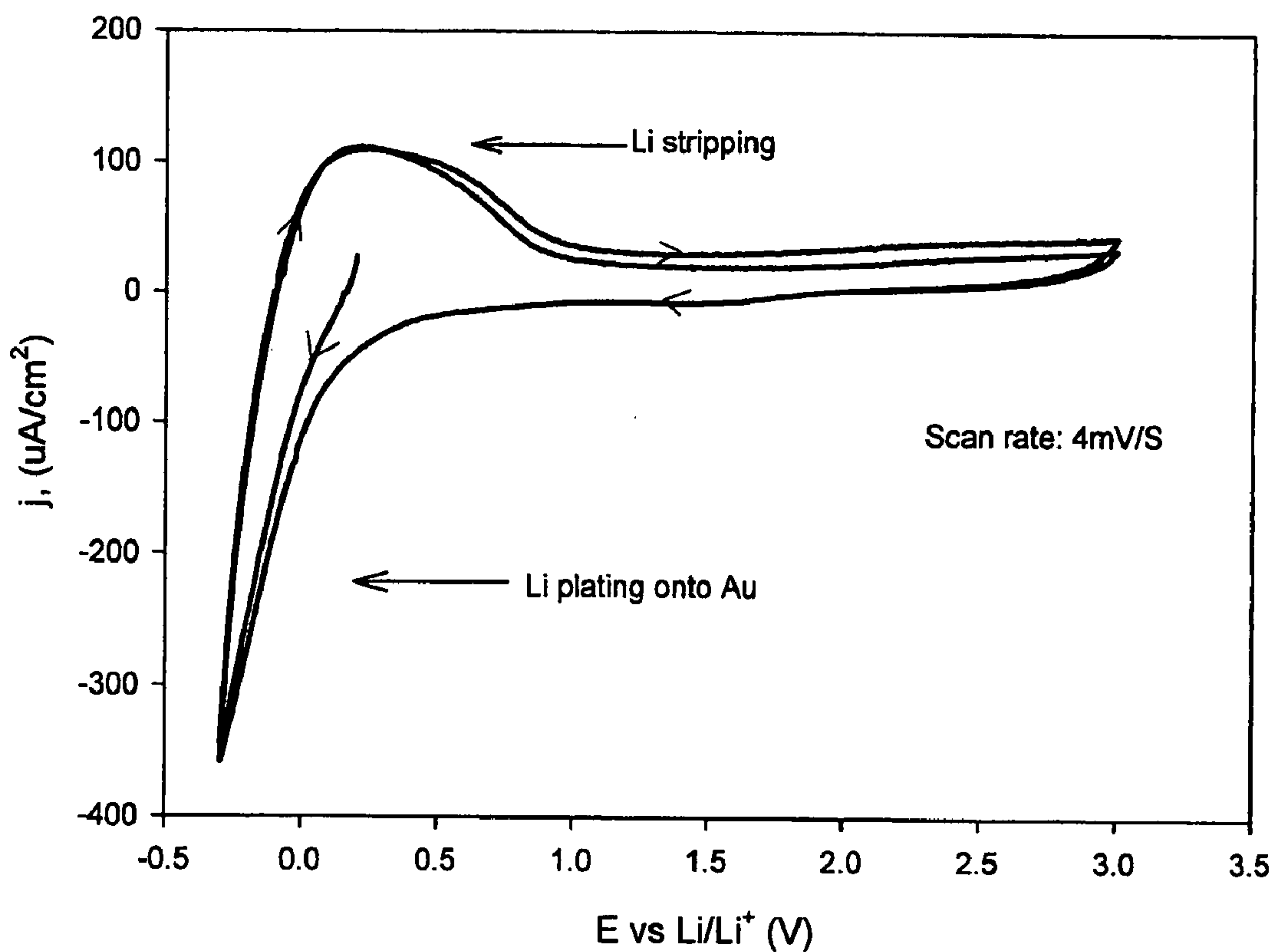

FIG. 8D

IONICALLY CONDUCTIVE COMPOSITES FOR PROTECTION OF ACTIVE METAL ANODES

CROSS-REFERENCE TO RELATED APPLICATIONS

[0001] This application claims priority to U.S. patent application Ser. No. 10/686,189 filed Oct. 14, 2003, titled IONICALLY CONDUCTIVE COMPOSITES FOR PROTECTION OF ACTIVE METAL ANODES, now pending, which in turn claims priority to U.S. Provisional Patent Application No. 60/418,899 filed Oct. 15, 2002, titled IONICALLY CONDUCTIVE COMPOSITES FOR PROTECTION OF ANODES AND ELECTROLYTES. These patent applications are incorporated herein by reference in its entirety for all purposes.

BACKGROUND OF THE INVENTION

[0002] 1. Field of the Invention

[0003] The present invention relates generally to separators and electrode structures for use in batteries. More particularly, this invention relates composites for protection of active metal anodes from deleterious reaction with air, moisture and other battery components and methods for their fabrication.

[0004] 2. Description of Related Art

[0005] The low equivalent weight of alkali metals, such as lithium, render them particularly attractive as a battery electrode component. Lithium provides greater energy per volume than the traditional battery standards, nickel and cadmium. Unfortunately, no rechargeable lithium metal batteries have yet succeeded in the market place.

[0006] The failure of rechargeable lithium metal batteries is largely due to cell cycling problems. On repeated charge and discharge cycles, lithium “dendrites” gradually grow out from the lithium metal electrode, through the electrolyte, and ultimately contact the positive electrode. This causes an internal short circuit in the battery, rendering the battery unusable after a relatively few cycles. While cycling, lithium electrodes may also grow “mossy” deposits which can dislodge from the negative electrode and thereby reduce the battery’s capacity.

[0007] To address lithium’s poor cycling behavior in liquid electrolyte systems, some researchers have proposed coating the electrolyte facing side of the lithium negative electrode with a “protective layer.” Such protective layer must conduct lithium ions, but at the same time prevent contact between the lithium electrode surface and the bulk electrolyte. Many techniques for applying protective layers have not succeeded.

[0008] Some contemplated lithium metal protective layers are formed in situ by reaction between lithium metal and compounds in the cell’s electrolyte which contact the lithium. Most of these in situ films are grown by a controlled chemical reaction after the battery is assembled. Generally, such films have a porous morphology allowing some electrolyte to penetrate to the bare lithium metal surface. Thus, they fail to adequately protect the lithium electrode.

[0009] Various pre-formed lithium protective layers have been contemplated. For example, U.S. Pat. No. 5,314,765 (issued to Bates on May 24, 1994) describes an ex situ

technique for fabricating a lithium electrode containing a thin layer of sputtered lithium phosphorus oxynitride (“LiPON”) or related material. LiPON is a glassy single ion conductor (conducts lithium ion) which has been studied as a potential electrolyte for solid state lithium microbatteries that are fabricated on silicon and used to power integrated circuits (See U.S. Pat. Nos. 5,597,660, 5,567,210, 5,338,625, and 5,512,147, all issued to Bates et al.).

[0010] Work in the present applicants’ laboratories has developed technology for the use of glassy or amorphous protective layers, such as LiPON, in active metal battery electrodes. (See, for example, U.S. Pat. No. 6,025,094, issued Feb. 15, 2000, U.S. Pat. No. 6,402,795, issued Jun. 11, 2002, U.S. Pat. No. 6,214,061, issued Apr. 10, 2001 and U.S. Pat. No. 6,413,284, issued Jul. 2, 2002, all issued to Visco, et al. and assigned to at PolyPlus Battery Company). Despite this progress, alternative protective layers and structures that could also enhance active metal, particularly lithium metal, battery performance continue to be sought. In particular, protective layers that combine the characteristics of high ionic conductivity and chemical stability to materials and conditions on either side of the protective layer are desired.

SUMMARY OF THE INVENTION

[0011] The present invention provides ionically conductive composites for protection of anodes and electrolytes and methods for their fabrication. The composites may be incorporated in active metal negative electrode (anode) structures and battery cells. In accordance with the invention, the properties of different ionic conductors are combined in a composite material that has the desired properties of high overall ionic conductivity and chemical stability towards the anode, the cathode and ambient conditions encountered in battery manufacturing. The composite is capable of protecting an active metal anode from deleterious reaction with other battery components or ambient conditions while providing a high level of ionic conductivity to facilitate manufacture and/or enhance performance of a battery cell in which the composite is incorporated.

[0012] The composite is composed of at least two layers of different materials having different chemical compatibility requirements. By “chemical compatibility” (or “chemically compatible”) it is meant that the referenced material does not react to form a product that is deleterious to battery cell operation when contacted with one or more other referenced battery cell components or manufacturing, handling or storage conditions. A first material layer (or first layer material) of the composite is ionically conductive, and chemically compatible with an active metal electrode material. Chemical compatibility in this aspect of the invention refers both to a material that is chemically stable and therefore substantially unreactive when contacted with an active metal electrode material. It may also refer to a material that is chemically stable with air, to facilitate storage and handling, and reactive when contacted with an active metal electrode material to produce a product that is chemically stable against the active metal electrode material and has the desirable ionic conductivity (i.e., a first layer material). Such a reactive material is sometimes referred to as a “precursor” material. A second material layer of the composite is substantially impervious, ionically conductive and chemically compatible with the first material. Additional layers are

possible to achieve these aims, or otherwise enhance electrode stability or performance. All layers of the composite have high ionic conductivity, at least 10^{-7} S/cm, generally at least 10^{-6} S/cm, for example at least 10^{-5} S/cm to 10^{-4} S/cm, and as high as 10^{-3} S/cm or higher so that the overall ionic conductivity of the multi-layer protective structure is at least 10^{-7} S/cm and as high as 10^{-3} S/cm or higher.

[0013] A wide variety of materials may be used in fabricating protective composites in accordance with the present invention, consistent with the principles described above. For example, the first layer, in contact with the active metal, may be composed, in whole or in part, of active metal nitrides, active metal phosphides, active metal halides or active metal phosphorus oxynitride-based glass. Specific examples include Li_3N , Li_3P , LiI , LiBr , LiCl , LiF and LiPON . These materials may be applied to the active metal electrode, or they may be formed in situ by application of precursors such as metal nitrides, metal phosphides, metal halides, red phosphorus, iodine, nitrogen or phosphorus containing organics and polymers, and the like. The in situ formation of the first layer may result from an incomplete conversion of the precursors to their lithiated analog. Nevertheless, such incomplete conversions meet the requirements of a first layer material for a protective composite in accordance with the present invention and are therefore within the scope of the invention.

[0014] A second layer of the protective composite may be composed of a substantially impervious glassy or amorphous ionic conductor, such as a phosphorus-based glass, oxide-based glass, phosphorus-oxynitride-based glass, sulphur-based glass, oxide/sulfide based glass, selenide based glass, gallium based glass, germanium-based glass, glass-ceramic active metal ion conductor, lithium beta-alumina, sodium beta-alumina, Li superionic conductor (LISICON), Na superionic conductor (NASICON), and the like. Specific examples include LiPON , Li_3PO_4 , Li_2S , SiS_2 , Li_2S , GeS_2 , Ga_2S_3 , Li_2O , $11\text{Al}_2\text{O}_3$, Na_2O , $11\text{Al}_2\text{O}_3$, $(\text{Na}, \text{Li})_{1-x}\text{Ti}_{2-x}\text{Al}_x(\text{PO}_4)_3$ ($0.6 \leq x \leq 0.9$) and crystallographically related structures, $\text{Na}_3\text{Zr}_2\text{Si}_2\text{PO}_{12}$, $\text{Li}_3\text{Zr}_2\text{Si}_2\text{PO}_{12}$, $\text{Na}_5\text{ZrP}_3\text{O}_{12}$, $\text{Na}_5\text{TiP}_3\text{O}_{12}$, $\text{Na}_3\text{Fe}_2\text{P}_3\text{O}_{12}$, $\text{Na}_4\text{NbP}_3\text{O}_{12}$, $\text{Li}_5\text{ZrP}_3\text{O}_{12}$, $\text{Li}_5\text{TiP}_3\text{O}_{12}$, $\text{Li}_3\text{Fe}_2\text{P}_3\text{O}_{12}$ and $\text{Li}_4\text{NbP}_3\text{O}_{12}$.

[0015] A particularly suitable glass-ceramic material for the second layer of the protective composite is a lithium ion conductive glass-ceramic having the following composition:

Composition	mol %
P_2O_5	26-55%
SiO_2	0-15%
$\text{GeO}_2 + \text{TiO}_2$	25-50%
in which GeO_2	0-50%
TiO_2	0-50%
ZrO_2	0-10%
M_2O_3	$0 < 10\%$
Al_2O_3	0-15%
Ga_2O_3	0-15%
Li_2O	3-25%

and containing a predominant crystalline phase composed of $\text{Li}_{1+x}(\text{M}, \text{Al}, \text{Ga})_x(\text{Ge}_{1-y}\text{Ti}_y)_{2-x}(\text{PO}_4)_3$ where $X \leq 0.8$ and $0 \leq Y \leq 1.0$, and where M is an element selected from the group consisting of Nd, Sm, Eu, Gd, Tb, Dy, Ho, Er, Tm and

Yb and/or and $\text{Li}_{1+x+y}\text{Q}_x\text{Ti}_{2-x}\text{Si}_y\text{P}_{3-y}\text{O}_{12}$ where $0 \leq X \leq 0.4$ and $0 \leq Y \leq 0.6$, and where Q is Al or Ga. The glass-ceramics are obtained by melting raw materials to a melt, casting the melt to a glass and subjecting the glass to a heat treatment. Such materials are available from OHARA Corporation, Japan and are further described in U.S. Pat. Nos. 5,702,995, 6,030,909, 6,315,881 and 6,485,622, incorporated herein by reference.

[0016] Either layer may also include additional components. For instance, a suitable active metal compatible layer (first layer) may include a polymer component to enhance its properties. For example, polymer-iodine complexes like poly(2-vinylpyridine)-iodine (P2VP-I₂), polyethylene-iodine, or with tetraalkylammonium-iodine complexes can react with Li to form a LiI-based film having significantly higher ionic conductivity than that for pure LiI. Also, a suitable first layer may include a material used to facilitate its use, for example, the residue of a wetting layer (e.g., Ag) used to prevent reaction between vapor phase lithium (during deposition) and LiPON when LiPON is used as a first layer material.

[0017] A suitable second layer may include a polymer component to enhance its properties. For example, a glass-ceramic active metal ion conductor, like the glass-ceramic materials described above, may also be combined with polymer electrolytes to form flexible composite sheets of material which may be used as second layer of the protective composite. One important example of such a flexible composite material has been developed by OHARA Corp. (Japan). It is composed of particles of a Li-ion conducting glass-ceramic material, such as described above, and a solid polymer electrolyte based on PEO-Li salt complexes. OHARA Corp. manufactures this material in the form of sheet with a thickness of about 50 microns that renders it flexible while maintaining its high ionic conductivity. Because of its relatively high ionic conductivity (better than 4×10^{-5} S/cm at room temperature in the case of the OHARA product) and stability toward metallic Li, this type of composite electrolyte can be used at room temperature or elevated temperatures in fully solid-state cells.

[0018] In addition, the layers may be formed using a variety of techniques. These include deposition or evaporation (including e-beam evaporation) of layers of material, such as LiN_3 or an ionically conductive glass. Also, as noted above, the active metal electrode adjacent layer may be formed in situ from the non-deleterious reaction of one or more precursors with the active metal electrode. For example, a LiN_3 layer may be formed on a Li anode by contacting CuN_3 with the Li anode surface, or LiP_3 may be formed on a Li anode by contacting red phosphorus with the Li anode surface.

[0019] The invention encompasses protected anode structures with fully-formed protective layers and battery separators incorporating ambient stable precursors, each of which may be handled or stored in normal ambient atmospheric conditions without degradation prior to incorporation into a battery cell. Battery cells and methods for making composites and battery cells are also provided.

[0020] These and other features of the invention will be further described and exemplified in the detailed description below.

BRIEF DESCRIPTION OF THE DRAWINGS

[0021] FIG. 1 is a schematic illustration of an active metal battery cell incorporating an ionically conductive protective composite in accordance with the present invention.

[0022] FIG. 2 is a schematic illustration of a protective composite battery separator in accordance with the present invention.

[0023] FIG. 3 is a schematic illustration of an active metal anode structure incorporating an ionically conductive protective composite in accordance with the present invention.

[0024] FIGS. 4A-B, 5 and 6A-B are schematic illustrations of alternative methods of making an electrochemical device structure incorporating an ionically conductive protective composite in accordance with the present invention.

[0025] FIGS. 7A-B and 8A-D are plots of data illustrating the performance benefits of ionically conductive protective composites in accordance with the present invention.

DETAILED DESCRIPTION OF SPECIFIC EMBODIMENTS

[0026] Reference will now be made in detail to specific embodiments of the invention. Examples of the specific embodiments are illustrated in the accompanying drawings. While the invention will be described in conjunction with these specific embodiments, it will be understood that it is not intended to limit the invention to such specific embodiments. On the contrary, it is intended to cover alternatives, modifications, and equivalents as may be included within the spirit and scope of the invention as defined by the appended claims. In the following description, numerous specific details are set forth in order to provide a thorough understanding of the present invention. The present invention may be practiced without some or all of these specific details. In other instances, well known process operations have not been described in detail in order not to unnecessarily obscure the present invention.

[0027] When used in combination with “comprising,” “a method comprising,” “a device comprising” or similar language in this specification and the appended claims, the singular forms “a,” “an,” and “the” include plural reference unless the context clearly dictates otherwise. Unless defined otherwise, all technical and scientific terms used herein have the same meaning as commonly understood to one of ordinary skill in the art to which this invention belongs.

[0028] Introduction

[0029] Ionically conductive composites for protection of anodes and electrolytes and methods for their fabrication. The composites may be incorporated in active metal negative electrode (anode) structures and battery cells. In accordance with the invention, the properties of different ionic conductors are combined in a composite material that has the desired properties of high overall ionic conductivity and chemical stability towards the anode, the cathode and ambient conditions encountered in battery manufacturing. The composite is capable of protecting an active metal anode from deleterious reaction with other battery components or ambient conditions while providing a high level of ionic conductivity to facilitate manufacture and/or enhance performance of a battery cell in which the composite is incorporated.

[0030] The composite is composed of at least two layers of different materials having different chemical compatibility requirements. By “chemical compatibility” (or “chemically compatible”) it is meant that the referenced material does not react to form a product that is deleterious to battery cell operation when contacted with one or more other referenced battery cell components or manufacturing, handling or storage conditions. A first material layer of the composite is both ionically conductive and chemically compatible with an active metal electrode material. Chemical compatibility in this aspect of the invention refers to a material that is chemically stable and therefore substantially unreactive when contacted with an active metal electrode material. Active metals are highly reactive in ambient conditions and can benefit from a barrier layer when used as electrodes. They are generally alkali metals such (e.g., lithium, sodium or potassium), alkaline earth metals (e.g., calcium or magnesium), and/or certain transitional metals (e.g., zinc), and/or alloys of two or more of these. The following active metals may be used: alkali metals (e.g., Li, Na, K), alkaline earth metals (e.g., Ca, Mg, Ba), or binary or ternary alkali metal alloys with Ca, Mg, Sn, Ag, Zn, Bi, Al, Cd, Ga, In. Preferred alloys include lithium aluminum alloys, lithium silicon alloys, lithium tin alloys, lithium silver alloys, and sodium lead alloys (e.g., Na₄Pb). A preferred active metal electrode is composed of lithium. Chemical compatibility also refers to a material that may be chemically stable with oxidizing materials and reactive when contacted with an active metal electrode material to produce a product that is chemically stable against the active metal electrode material and has the desirable ionic conductivity (i.e., a first layer material). Such a reactive material is sometimes referred to as a “precursor” material.

[0031] A second material layer of the composite is substantially impervious, ionically conductive and chemically compatible with the first material. By substantially impervious it is meant that the material provides a sufficient barrier to battery electrolytes and solvents and other battery component materials that would be damaging to the electrode material to prevent any such damage that would degrade electrode performance from occurring. Thus, it should be non-swellable and free of pores, defects, and any pathways allowing air, moisture, electrolyte, etc. to penetrate though it to the first material. Preferably, the second material layer is so impervious to ambient moisture, carbon dioxide, oxygen, etc. that an encapsulated lithium alloy electrode can be handled under ambient conditions without the need for elaborate dry box conditions as typically employed to process other lithium electrodes. Because the composite protective layer described herein provides such good protection for the lithium (or other active metal), it is contemplated that electrodes and electrode/electrolyte composites of this invention may have a quite long shelf life outside of a battery. Thus, the invention contemplates not only batteries containing a negative electrode, but unused negative electrodes and electrode/electrolyte laminates themselves. Such negative electrodes and electrode/electrolyte laminates may be provided in the form of sheets, rolls, stacks, etc. Ultimately, they are integrated with other battery components to fabricate a battery. The enhanced stability of the batteries of this invention will greatly simplify this fabrication procedure.

[0032] It should be noted that the first and second materials are inherently ionically conductive. That is, they do not

depend on the presence of a liquid electrolyte or other agent for their ionically conductive properties.

[0033] Additional layers are possible to achieve these aims, or otherwise enhance electrode stability or performance. All layers of the composite have high ionic conductivity, at least 10^{-7} S/cm, generally at least 10^{-6} S/cm, for example at least 10^{-5} S/cm to 10^{-4} S/cm, and as high as 10^{-3} S/cm or higher so that the overall ionic conductivity of the multi-layer protective structure is at least 10^{-7} S/cm and as high as 10^{-3} S/cm or higher.

[0034] Protective Composites and Structures

[0035] FIG. 1 illustrates an ionically conductive protective composite in accordance with the present invention in context as it would be used in an active metal battery cell 120, such as a lithium-sulfur battery, in accordance with the present invention. The composite 100 is composed of a first layer 102 of a material that is both ionically conductive and chemically compatible with an active metal electrode material. The composite also includes second layer 104 of a material that is substantially impervious, ionically conductive and chemically compatible with the first material. The ionic conductivity of the composite is at least 10^{-7} S/cm, generally at least 10^{-6} S/cm, for example at least 10^{-5} S/cm to 10^{-4} S/cm, and as high as 10^{-3} S/cm or higher. The first layer 102 is adjacent to an active metal (e.g., lithium) anode 106. The active metal cathode 106 is connected with a current collector 108, composed of a conductive metal such as copper. On the other side of the composite 100, the second layer 104 is (optionally) in contact with an electrolyte 110. Alternatively, in some embodiments, the second layer 104 may itself be the sole electrolyte of the battery cell. Adjacent to the electrolyte is the cathode 112 with its current collector 114.

[0036] FIG. 2 illustrates a protective composite battery separator in accordance with the present invention. The separator 200 includes a layer of a first material or precursor 202 that is ionically conductive and chemically compatible with an active metal. In most cases, the first material is not chemically compatible with oxidizing materials (e.g., air, moisture, etc). The first layer, in contact with the active metal, may be composed, in whole or in part, of active metal nitrides, active metal phosphides, active metal halides or active metal phosphorus oxynitride-based glasses. Specific examples include Li_3N , Li_3P , LiI , LiBr , LiCl and LiF . In at least one instance, LiPON , the first material is chemically compatible with oxidizing materials. The thickness of the first material layer is preferably about 0.1 to 5 microns, or 0.2 to 1 micron, for example about 0.25 micron.

[0037] As noted above, the first material may also be a precursor material which is chemically compatible with an active metal and reactive when contacted with an active metal electrode material to produce a product that is chemically stable against the active metal electrode material and has the desirable ionic conductivity (i.e., a first layer material). Examples of suitable precursor materials include metal nitrides, red phosphorus, nitrogen and phosphorus containing organics (e.g., amines, phosphines, borazine ($\text{B}_3\text{N}_3\text{H}_6$), triazine ($\text{C}_3\text{N}_3\text{H}_3$)) and halides. Some specific examples include P (red phosphorus), Cu_3N , SnN_x , Zn_3N_2 , FeN_x , CoN_x , aluminum nitride (AlN), silicon nitride (Si_3N_4) and I_2 , Br_2 , Cl_2 and F_2 . Such precursor materials can subsequently react with active metal (e.g., Li) to form a Li metal

salts, such as the lithium nitrides, phosphides and halides described above. In some instances, these first layer material precursors may also be chemically stable in air (including moisture and other materials normally present in ambient atmosphere), thus facilitating handling and fabrication. Examples include metal nitrides, for example Cu_3N .

[0038] Also, a suitable active metal compatible layer may include a polymer component to enhance its properties. For example, polymer-iodine complexes like poly(2-vinylpyridine)-iodine (P2VP-I_2), polyethylene-iodine, or with tetraalkylammonium-iodine complexes can react with Li to form a LiI-based film having significantly higher ionic conductivity than that for pure LiI.

[0039] The ionic conductivity of the first material is high, at least 10^{-7} S/cm, generally at least about 10^{-5} S/cm, and may be as high as 10^{-3} S/cm or higher.

[0040] Adjacent to the first material or precursor layer 202 is a second layer 204 that is substantially impervious, ionically conductive and chemically compatible with the first material or precursor, such as a phosphorus-based glass, oxide-based glass, phosphorus-oxynitride-based glass, sulphur-based glass, oxide/sulfide based glass, selenide based glass, gallium based glass, germanium-based glass, glass-ceramic active metal ion conductor, lithium beta-alumina, sodium beta-alumina, Li superionic conductor (LISICON), Na superionic conductor (NASICON), and the like. Specific examples include LiPON , Li_3PO_4 , Li_2S , SiSi_2 , Li_2S , GeS_2 , Ga_2S_3 , Li_2O , $11\text{Al}_2\text{O}_3$, Na_2O , $11\text{Al}_2\text{O}_3$, $(\text{Na}, \text{Li})_{1+x}\text{Ti}_{2-x}\text{Al}_x(\text{PO}_4)_3$ ($0.6 \leq x \leq 0.9$) and crystallographic related structures, $\text{Na}_3\text{Zr}_2\text{Si}_2\text{PO}_{12}$, $\text{Li}_3\text{Zr}_2\text{Si}_2\text{PO}_{12}$, $\text{Na}_5\text{ZrP}_3\text{O}_{12}$, $\text{Na}_5\text{TiP}_3\text{O}_{12}$, $\text{Na}_3\text{Fe}_2\text{P}_3\text{O}_{12}$, $\text{Na}_4\text{NbP}_3\text{O}_{12}$, $\text{Li}_5\text{ZrP}_3\text{O}_{12}$, $\text{Li}_5\text{TiP}_3\text{O}_{12}$, $\text{Li}_3\text{Fe}_2\text{P}_3\text{O}_{12}$ and $\text{Li}_4\text{NbP}_3\text{O}_{12}$.

[0041] A particularly suitable glass-ceramic material for the second layer of the protective composite is a lithium ion conductive glass-ceramic having the following composition:

Composition	mol %
P_2O_5	26-55%
SiO_2	0-15%
$\text{GeO}_2 + \text{TiO}_2$	25-50%
in which GeO_2	0-50%
TiO_2	0-50%
ZrO_2	0-10%
M_2O_3	$0 < 10\%$
Al_2O_3	0-15%
Ga_2O_3	0-15%
Li_2O	3-25%

and containing a predominant crystalline phase composed of $\text{Li}_{1+x}(\text{M}, \text{Al}, \text{Ga})_x(\text{Ge}_{1-y}\text{Ti}_y)_{2-x}(\text{PO}_4)_3$ where $X \leq 0.8$ and $0 \leq Y \leq 1.0$, and where M is an element selected from the group consisting of Nd, Sm, Eu, Gd, Tb, Dy, Ho, Er, Tm and Yb and/or and $\text{Li}_{1+x+y}\text{Q}_x\text{Ti}_{2-x}\text{Si}_y\text{P}_{3-y}\text{O}_{12}$ where $0 < X \leq 0.4$ and $0 < Y \leq 0.6$, and where Q is Al or Ga. The glass-ceramics are obtained by melting raw materials to a melt, casting the melt to a glass and subjecting the glass to a heat treatment. Such materials are available from OHARA Corporation, Japan and are further described in U.S. Pat. Nos. 5,702,995, 6,030,909, 6,315,881 and 6,485,622, incorporated herein by reference.

[0042] The high conductivity of some of these glasses and glass-ceramics (ionic conductivity in the range of about 10^{-5}

to 10^{-3} S/cm or greater) may enhance performance of the protected lithium anode, and allow relatively thick films to be deposited without a large penalty in terms of ohmic resistance.

[0043] Also, a suitable second layer may include a polymer component to enhance its properties. For example, a glass-ceramic active metal ion conductor, like the glass-ceramic materials described above, may also be combined with polymer electrolytes to form flexible composite sheets of material which may be used as second layer of the protective composite. One important example of such a flexible composite material has been developed by OHARA Corp. (Japan). It is composed of particles of a Li-ion conducting glass-ceramic material, such as described above, and a solid polymer electrolyte based on PEO-Li salt complexes. OHARA Corp. manufactures this material in the form of sheet with a thickness of about 50 microns that renders it flexible while maintaining its high ionic conductivity. Because of its relatively high ionic conductivity (better than 4×10^{-5} S/cm at room temperature in the case of the OHARA product) and stability toward metallic Li, this type of composite electrolyte can be used at room temperature or elevated temperatures in fully solid-state cells.

[0044] The composite barrier layer should have an inherently high ionic conductivity. In general, the ionic conductivity of the composite is at least 10^{-7} S/cm, generally at least about 10^{-6} to 10^{-5} S/cm, and may be as high as 10^{-4} to 10^{-3} S/cm or higher. The thickness of the first precursor material layer should be enough to prevent contact between the second material layer and adjacent materials or layers, in particular, the active metal of the anode with which the separator is to be used. For example, the first material layer may have a thickness of about 0.1 to 5 microns; 0.2 to 1 micron; or about 0.25 micron.

[0045] The thickness of the second material layer is preferably about 0.1 to 1000 microns, or, where the ionic conductivity of the second material layer is about 10^{-7} S/cm, about 0.25 to 1 micron, or, where the ionic conductivity of the second material layer is between about 10^{-4} about 10^{-3} S/cm, about 10 to 1000 microns, preferably between 1 and 500 microns, and more preferably between 10 and 100 microns, for example 20 microns.

[0046] When the first material layer is a precursor material chemically stable in air, for example Cu_3N or LiPON, the protective composite battery separator may be handled or stored in normal ambient atmospheric conditions without degradation prior to incorporation into a battery cell. When the separator is incorporated into a battery cell, the precursor layer 202 is contacted with an active metal (e.g., lithium) electrode. The precursor reacts with the active metal to form an ionically conductive material that is chemically compatible with the active metal electrode material. The second layer is contacted with an electrolyte to which a cathode and current collector is or has been applied. Alternatively, the second layer acts as the sole electrolyte in the battery cell. In either case, the combination of the two layers in the protective composite protects the active metal electrode and the electrolyte and/or cathode from deleterious reaction with one another.

[0047] FIG. 3 illustrates an encapsulated anode structure incorporating a protective composite in accordance with the present invention. The structure 300 includes an active metal

electrode 308, e.g., lithium, bonded with a current collector 310, e.g., copper, and a protective composite 302. The protective composite 302 is composed of a first layer 304 of a material that is both ionically conductive and chemically compatible with an active metal electrode material, but not chemically compatible with oxidizing materials (e.g., air). For example, the first layer, in contact with the active metal, may be composed, in whole or in part, of active metal nitrides, active metal phosphides or active metal halides. Specific examples include Li_3N , Li_3P , LiI, LiBr, LiCl and LiF. The thickness of the first material layer is preferably about 0.1 to 5 microns, or 0.2 to 1 micron, for example about 0.25 micron.

[0048] These first layer materials may be applied to the active metal electrode, or they may be formed in situ by application of precursors such as metal nitrides, metal phosphides, metal halides, red phosphorus, iodine and the like. The in situ formation of the first layer may be by way of conversion of the precursors to a lithiated analog, for example, according to reactions of the following type (using P, CuN_3 , and PbI_2 precursors as examples):

[0049] 1. $3\text{Li} + \text{P} = \text{Li}_3\text{P}$ (reaction of the precursor to form Li-ion conductor);

[0050] 2(a). $3\text{Li} + \text{Cu}_3\text{N} = \text{Li}_3\text{N} + 3\text{Cu}$ (reaction to form Li-ion conductor/metal composite);

[0051] 2(b). $2\text{Li} + \text{PbI}_2 = 2\text{LiI} + \text{Pb}$ (reaction to form Li-ion conductor/metal composite).

[0052] First layer composites, which may include electronically conductive metal particles, formed as a result of in situ conversions meet the requirements of a first layer material for a protective composite in accordance with the present invention and are therefore within the scope of the invention.

[0053] A second layer 306 of the protective composite is composed of a substantially impervious glassy or amorphous ionic conductor, such as a phosphorus-based glass, oxide-based glass, phosphorus-oxynitride-based glass, sulphur-based glass, oxide/sulfide based glass, selenide based glass, gallium based glass, germanium-based glass, glass-ceramic active metal ion conductor, lithium beta-alumina, sodium beta-alumina, Li superionic conductor (LISICON), Na superionic conductor (NASICON), and the like. Specific examples include LiPON, Li_3PO_4 , $\text{Li}_2\text{S} \cdot \text{SiS}_2$, $\text{Li}_2\text{S} \cdot \text{GeS}_2 \cdot \text{Ga}_2\text{S}_3$, $\text{Li}_{1-x-y}\text{Al}_x\text{Ti}_{2-x}\text{Si}_y\text{P}_{3-y}\text{O}_{12}$ (available from OHARA Corporation, Japan; further described in U.S. Pat. Nos. 5,702,995, 6,030,909, 6,315,881, incorporated herein by reference), $\text{Li}_2\text{O} \cdot 11\text{Al}_2\text{O}_3$, $\text{Na}_2\text{O} \cdot 11\text{Al}_2\text{O}_3$, $(\text{Na}, \text{Li})_{1+x}\text{Ti}_{2-x}\text{Al}_x(\text{PO}_4)_3$ ($0.6 \leq x \leq 0.9$) and crystallographically related structures, $\text{Na}_3\text{Zr}_2\text{Si}_2\text{PO}_{12}$, $\text{Li}_3\text{Zr}_2\text{Si}_2\text{PO}_{12}$, $\text{Na}_5\text{ZrP}_{12}$, $\text{Na}_5\text{TiP}_3\text{O}_{12}$, $\text{Na}_3\text{Fe}_2\text{P}_3\text{O}_{12}$, $\text{Na}_4\text{NbP}_3\text{O}_{12}$, $\text{Li}_5\text{ZrP}_3\text{O}_{12}$, $\text{Li}_3\text{Fe}_2\text{P}_3\text{O}_{12}$, $\text{Li}_3\text{Fe}_2\text{P}_3\text{O}_{12}$ and $\text{Li}_4\text{NbP}_3\text{O}_{12}$.

[0054] The ionic conductivity of the composite is at least 10^{-7} S/cm, generally at least 10^{-6} S/cm, for example at least 10^{-5} S/cm to 10^{-4} S/cm, and as high as 10^{-3} S/cm or higher. The thickness of the second material layer is preferably about 0.1 to 1000 microns, or, where the ionic conductivity of the second material layer is about 10^{-7} S/cm, about 0.25 to 1 micron, or, where the ionic conductivity of the second material layer is between about 10^{-4} about 10^{-3} S/cm, 10 to 1000 microns, preferably between 1 and 500 micron, and more preferably between 10 and 100 microns, for example 20 microns.

[0055] When the anode structure is incorporated in a battery cell, the first layer **304** is adjacent to an active metal (e.g., lithium) anode and the second layer **306** is adjacent to an electrolyte or, where the second layer is the sole electrolyte in the battery cell, a cathode.

[0056] Either layer may also include additional components. For instance, a suitable first active metal compatible layer **304** may include a polymer component to enhance its properties. For example, polymer-iodine complexes like poly(2-vinylpyridine)-iodine (P2VP-I₂), polyethylene-iodine, or with tetraalkylammonium-iodine can react with Li to form a Liu-based film having significantly higher ionic conductivity than that for pure LiI. Also, a suitable second layer **306** may include a polymer component to enhance its properties. For example, a glass-ceramic active metal ion conductor like that available from OHARA Corporation, described above, may be fabricated within a polymer matrix that renders it flexible while maintaining its high ionic conductivity (available from OHARA Corporation, Japan).

[0057] In addition, the layers may be formed using a variety of techniques. These include deposition or evaporation (including e-beam evaporation) of layers of material, such as LiN₃ or an ionically conductive glass. Also, as noted above, the active metal electrode adjacent layer may be formed in situ from the non-deleterious reaction of one or more precursors with the active metal electrode. For example, a LiN₃ layer may be formed on a Li anode by contacting CuN₃ with the Li anode surface, or LiP₃ may be formed on a Li anode by contacting red phosphorus with the Li anode surface.

[0058] Also, an approach may be used where a first material and second material are coated with another material such as a transient and/or wetting layer. For example, an OHARA glass ceramic plate is coated with a LiPON layer, followed by a thin silver (Ag) coating. When lithium is evaporated onto this structure, the Ag is converted to Ag—Li and diffuses, at least in part, into the greater mass of deposited lithium, and a protected lithium electrode is created. The thin Ag coating prevents the hot (vapor phase) lithium from contacting and adversely reaction with the LiPON first material layer. After deposition, the solid phase lithium is stable against the LiPON. A multitude of such transient/wetting (e.g., Sn) and first layer material combinations can be used to achieve the desired result.

[0059] Thus, the invention encompasses protected anode structures with fully-formed protective layers and battery separators incorporating ambient stable precursors, each of which may be handled or stored in normal ambient atmospheric conditions without degradation prior to incorporation into a battery cell. Battery cells and methods for making separators, anode structures and battery cells are also provided.

[0060] Fabrication Techniques

[0061] Materials and techniques for fabrication of active metal battery cells are described, for example, in U.S. Pat. No. 5,686,201 issued to Chu on Nov. 11, 1997. Further description of materials and techniques for fabrication of active metal battery cells having anode protective layers are described, for example, in U.S. patent application Ser. No. 09/139,601, filed Aug. 25, 1998 (now U.S. Pat. No. 6,214,061, issued Apr. 10, 2001), titled ENCAPSULATED

LITHIUM ALLOY ELECTRODES HAVING BARRIER LAYERS, and naming May-Ying Chu, Steven J. Visco and Lutgard C. DeJonge as inventors; U.S. patent application Ser. No. 09/086,665 filed May 29, 1998 (now U.S. Pat. No. 6,025,094, issued May 15, 2000), titled PROTECTIVE COATINGS FOR NEGATIVE ELECTRODES, and naming Steven J. Visco and May-Ying Chu as inventors; U.S. patent application Ser. No. 09/139,603 filed Aug. 25, 1998 (now U.S. Pat. No. 6,402,795, issued Jun. 11, 2002), titled “PLATING METAL NEGATIVE ELECTRODES UNDER PROTECTIVE COATINGS,” and naming May-Ying Chu, Steven J. Visco and Lutgard C. DeJonge as inventors; U.S. patent application Ser. No. 09/139,601 filed Aug. 25, 1998 (now U.S. Pat. No. 6,214,061, issued Apr. 10, 2001), titled “METHOD FOR FORMING ENCAPSULATED LITHIUM ELECTRODES HAVING GLASS PROTECTIVE LAYERS,” and naming Steven J. Visco and Floris Y. Tsang as inventors. The active metal electrode may also be an active metal alloy electrode, as further described in U.S. patent application Ser. No. 10/189,908 filed Jul. 3, 2002, titled “ENCAPSULATED ALLOY ELECTRODES,” and naming Steven J. Visco, Yevgeniy S. Nimon and Bruce D. Katz as inventors. The battery component materials, including anodes, cathodes, separators, protective layers, etc., and techniques disclosed therein are generally applicable to the present invention and each of these patent applications is incorporated herein by reference in its entirety for all purposes.

[0062] In particular, a protective composite in accordance with the present invention may be formed using a variety of methods. These include deposition or evaporation (including e-beam evaporation) of the first layer of material or precursor on the second layer of material. Also, as noted above and described further below, the first layer may be formed in situ from the non-deleterious reaction of one or more precursors with an active metal electrode or material, by deposition or evaporation of lithium on the precursor, by direct contact of the precursor with a lithium metal (e.g., foil), or by plating of the precursor with lithium through a second layer material. In some embodiments, the second layer material may also be formed on the first layer material, as described further below.

[0063] Referring to FIG. 4A, a first method for forming a protective composite in accordance with the present invention is shown. A first layer, that is a highly ionically conductive active metal chemically compatible material, is directly deposited onto a second layer material, that is a substantially impervious, ionically conductive material, for example, a highly ionically conductive glass or glass-ceramic material such as LiPON or an OHARA glass-ceramic material described above. This can be done by a variety of techniques including RF sputtering, e-beam evaporation, thermal evaporation, or reactive thermal or e-beam evaporation, for example. In the particular example illustrated in the figure, lithium is evaporated in a nitrogen plasma to form a lithium nitride (Li₃N) layer on the surface of a glass-ceramic material such as the OHARA material described above. This is followed by evaporation of lithium metal onto the Li₃N film. The Li₃N layer separates the lithium metal electrode from the second material layer, but allows Li ions to pass from the Li electrode through the glass. Of course, other active metal, and first and second layer materials, as described herein, may be used as well.

[0064] Alternatively, referring to FIG. 4B, a second method for forming a protective composite in accordance with the present invention is shown. The ionically conductive chemically compatible first layer material is formed in situ following formation of a precursor layer on the second layer material. In the particular example illustrated in the figure, a surface of a glass-ceramic layer, for example one composed of the OHARA material described above, is coated with red phosphorus, a precursor for an active metal (in this case lithium) phosphide. Then a layer of lithium metal is deposited onto the phosphorus. The reaction of lithium and phosphorus forms Li_3P according to the following reaction: $3\text{Li} + \text{P} = \text{Li}_3\text{P}$. Li_3P is an ionically conductive material that is chemically compatible with both the lithium anode and the glass-ceramic material. In this way, the glass-ceramic (or other second layer material) is not in direct contact with the lithium electrode. Of course, other active metal, first layer precursor and second layer materials, as described herein, may be used as well. Alternative precursor examples include CuN_3 , which may be formed as a thin layer on a second layer material (e.g., glass-ceramic) and contacted with a Li anode in a similar manner according to the following reaction: $3\text{Li} + \text{Cu}_3\text{N} = \text{Li}_3\text{N} + 3\text{Cu}$; or lead iodide which may be formed as a thin layer on a polymer electrolyte and contacted with a Li anode in a similar manner according to the following reaction: $2\text{Li} + \text{PbI}_2 = 2\text{LiI} + \text{Pb}$.

[0065] In either of the forgoing methods, rather than forming a lithium (or other active metal) layer on the first layer material or precursor, the first layer material or precursor of the protective composite may be contacted with the lithium by bonding metallic lithium to the protective inter-layer material or precursor, for example by direct contact with extruded lithium metal foil. One embodiment of this alternative is illustrated for either of the FIG. 4A or FIG. 4B methods in FIG. 5.

[0066] In a further embodiment, a suitable substrate, e.g., having a wetting layer, such as a film of tin on copper, may be coated with a first layer material precursor, e.g., Cu_3N . This may then be coated with a second layer material, e.g., a (ionically) conductive glass. An active metal electrode may then be formed by plating the tin electrode with lithium (or other active metal), through the first and second layer materials. The Cu_3N precursor is also converted to Li_3N by this operation to complete the protective composite in accordance with the present invention on a lithium metal electrode. Details of an active metal plating process are described in commonly assigned U.S. Pat. No. 6,402,795, previously incorporated by reference.

[0067] Also, in either of the methods illustrated in FIGS. 4A or 4B, rather than forming a lithium (or other active metal) layer on the first layer material or precursor, the first layer material or precursor of the protective composite may be deposited (or otherwise formed) on lithium or other active metal material. Then, a second later material may be formed, for example by evaporation of a high conductivity glass, on the first layer material. One embodiment of this alternative is illustrated in FIG. 5 in which the active metal electrode is formed by evaporating lithium onto a pre-formed copper-tin (Cu—Sn) alloy to form a pre-expanded Li—Cu—Sn alloy anode as a substrate for the first and second layer materials forming the protective composite.

[0068] Also as noted above, in an alternative embodiment of the invention the first layer may include additional

components. For instance, a suitable first layer may include a polymer component to enhance its properties. For example, polymer-iodine complexes like poly(2-vinylpyridine)-iodine (P2VP-I_2), polyethylene-iodine, or tetraalkylammonium-iodine can react with Li to form an ionically conductive LiI-based film that is chemically compatible with both an active metal and a second layer material as described herein. Without intending to be bound by theory, it is expected that the use of polymer-iodine charge transfer complexes can lead to formation of composites containing LiI and polymer and having significantly higher ionic conductivity than that for pure LiI. Other halogens may also be used in this manner, for example in bromine complexes.

[0069] Referring to FIG. 6A, a first embodiment of this aspect of the present invention is shown. A polymer layer and a layer of iodine are coated on a second layer material surface and allowed to react forming polymer-iodine complex.

[0070] According to this method, a thin layer of polymer may be applied to the second material layer (e.g., conductive glass) using brushing, dipping, or spraying. For example, a conductive glass layer may be coated with a thin (e.g., 0.5 to 2.0 micron, preferably 0.1 to 0.5 micron) layer of P2VP in this way.

[0071] One technique for applying an iodine coating is sublimation of crystalline iodine that can be achieved at room temperature (e.g., about 20 to 25° C.) in a reactor placed in the dry box or in a dry room. A sublimed layer of iodine can be made very thin (e.g., 0.05 to 1.0 microns) and the rate of sublimation can be adjusted by varying the temperature or distance between the substrate and source of iodine.

[0072] Alternatively, high concentrations (e.g., 50 to 100 g/liter) of iodine can be dissolved in an organic solvent, such as acetonitrile and n-heptane. Dissolved iodine can be coated on the conductive glass surface by such methods as dip coating, spraying or brushing, among others. In this case, treatment conditions can be easily changed by varying the length of coating treatment and iodine concentrations. Examples of iodine sources for this technique include metal iodides are AgI and PbI_2 , which are known to be used as the cathode materials in solid-state batteries with Li anode and LiI-based solid electrolyte.

[0073] Then, lithium (or other active metal) is contacted with the polymer-iodine complex on the conductive glass (or other second layer material), for example by evaporation or pressing onto the glass coated with this complex. The result is a LiI-containing composite protective barrier layer on the Li anode.

[0074] Referring to FIG. 6B, an alternative embodiment of this aspect of the present invention is shown. A conductive glass (or other second layer material) surface is coated with a thin layer of iodine, such as by a technique described above, that can react with Li forming LiI layer (A).

[0075] Active metal, for example lithium foil, can be coated with a thin layer of polymer (B), for example as described above, and then contacted with the iodine layer on the glass. After assembly, iodine reacts with the polymer layer and, as a result, LiI-containing composite protective barrier layer with reduced impedance is formed.

EXAMPLES

[0076] The following examples provide details illustrating advantageous properties, in particular very low impedance, of composite protective structures in accordance with the present invention on lithium electrodes. These examples are provided to exemplify and more clearly illustrate aspects of the present invention and are in no way intended to be limiting.

Example 1

Impedance Measurements using LiPON in Composite Protective Layer

[0077] Approximately 0.75 microns of LiPON was RF sputter-deposited onto copper foil samples in a MRC 8671 Sputter Deposition system. Some of the copper foil samples were coated with an additional layer of Cu_3N (approximately 0.9 microns) by RF Magnetron sputtering of a copper target in a nitrogen environment. One LiPON/Cu sample was transferred to a vacuum evaporator, and approximately 3 to 7 microns of lithium metal was evaporated directly onto the LiPON surface. Another Cu_3N /LiPON/Cu sample was coated with a similar thickness of lithium. The impedance for the unprotected LiPON/Cu sample is shown in FIG. 7A; the evaporation of lithium onto the LiPON surface led to a dramatic rise in the resistance of the sample, which is undesirable for electrochemical devices. The beneficial effects of the protective Cu_3N film is seen in FIG. 7B; the impedance is dramatically lower in this case.

Example 2

Impedance Measurements using Glass-Ceramic Active Metal Ion Conductor (OHARA) in Composite Protective Layer

[0078] Samples of Li^+ conductive glass-ceramic plates were received from OHARA Corporation. Approximately 3 to 7 microns of lithium was evaporated directly onto the OHARA glass-ceramic plate. The deleterious reaction of lithium with the electrolyte is seen in FIG. 8A; the impedance of the sample is quite large, approximately $40,000 \text{ Wcm}^2$. Onto a second sample of glass-ceramic plate was RF Magnetron sputter-deposited a film of Cu_3N (~0.9 microns thick), with subsequent evaporation of about 3 to 7 microns

of lithium. The beneficial effect of the Cu_3N film can be seen in FIG. 8B; the impedance of the glass-ceramic is dramatically improved relative to the plate without the Cu_3N film. Superimposition of FIGS. 8A and 8B in FIG. 8C further illustrates the dramatic improvement in performance for the Cu_3N protected plate. The ionically conductive nature of the protective film is seen in 8D, where lithium is moved across the Li/ Cu_3N /glass interface; this is presumably due to conversion of the ionically insulating Cu_3N film to highly conductive $\text{Li}_3\text{N}+\text{Cu}$.

CONCLUSION

[0079] Although the foregoing invention has been described in some detail for purposes of clarity of understanding, it will be apparent that certain changes and modifications may be practiced within the scope of the appended claims. It should be noted that there are many alternative ways of implementing both the process and compositions of the present invention. Accordingly, the present embodiments are to be considered as illustrative and not restrictive, and the invention is not to be limited to the details given herein.

[0080] All references cited herein are incorporated by reference for all purposes.

What is claimed is:

1. An electrochemical device component, comprising:

an active metal electrode having a first surface and a second surface;

a protective composite separator on the first surface of the electrode, the composite comprising,

a first material layer in contact with the electrode, the first material being ionically conductive and chemically compatible with the active metal; and

a second material layer in contact with the first layer, the second material being substantially impervious, ionically conductive and chemically compatible with the first material;

wherein the ionic conductivity of the composite is at least 10^{-7} S/cm .

2-72. (canceled)

* * * * *