



US 20080042321A1

(19) **United States**

(12) **Patent Application Publication**
Russell et al.

(10) **Pub. No.: US 2008/0042321 A1**

(43) **Pub. Date: Feb. 21, 2008**

(54) **APPARATUS AND METHODS FOR 3D PRINTING**

Related U.S. Application Data

(75) Inventors: **David Russell**, Burlington, MA (US);
Andres T. Hernandez, Glendale, CA (US);
Joshua Kingsley, Arlington, MA (US);
Andrew Berlin, Gloucester, MA (US)

(63) Continuation of application No. 10/817,159, filed on Apr. 2, 2004, now Pat. No. 7,291,002.

(60) Provisional application No. 60/472,922, filed on May 23, 2003.

Publication Classification

Correspondence Address:
GOODWIN PROCTER LLP
PATENT ADMINISTRATOR
EXCHANGE PLACE
BOSTON, MA 02109-2881 (US)

(51) **Int. Cl.**
B28B 1/14 (2006.01)
B08B 5/00 (2006.01)

(52) **U.S. Cl.** **264/308; 134/21; 15/4**

(57) **ABSTRACT**

The invention relates to apparatus and methods for producing three-dimensional objects and auxiliary systems used in conjunction with the aforementioned apparatus and methods. The apparatus and methods involve continuously printing radially about a circular and/or rotating build table using multiple printheads. The apparatus and methods also include optionally using multiple build tables. The auxiliary systems relate to build material supply, printhead cleaning, diagnostics, and monitoring operation of the apparatus.

(73) Assignee: **Z Corporation**, Burlington, MA

(21) Appl. No.: **11/860,087**

(22) Filed: **Sep. 24, 2007**

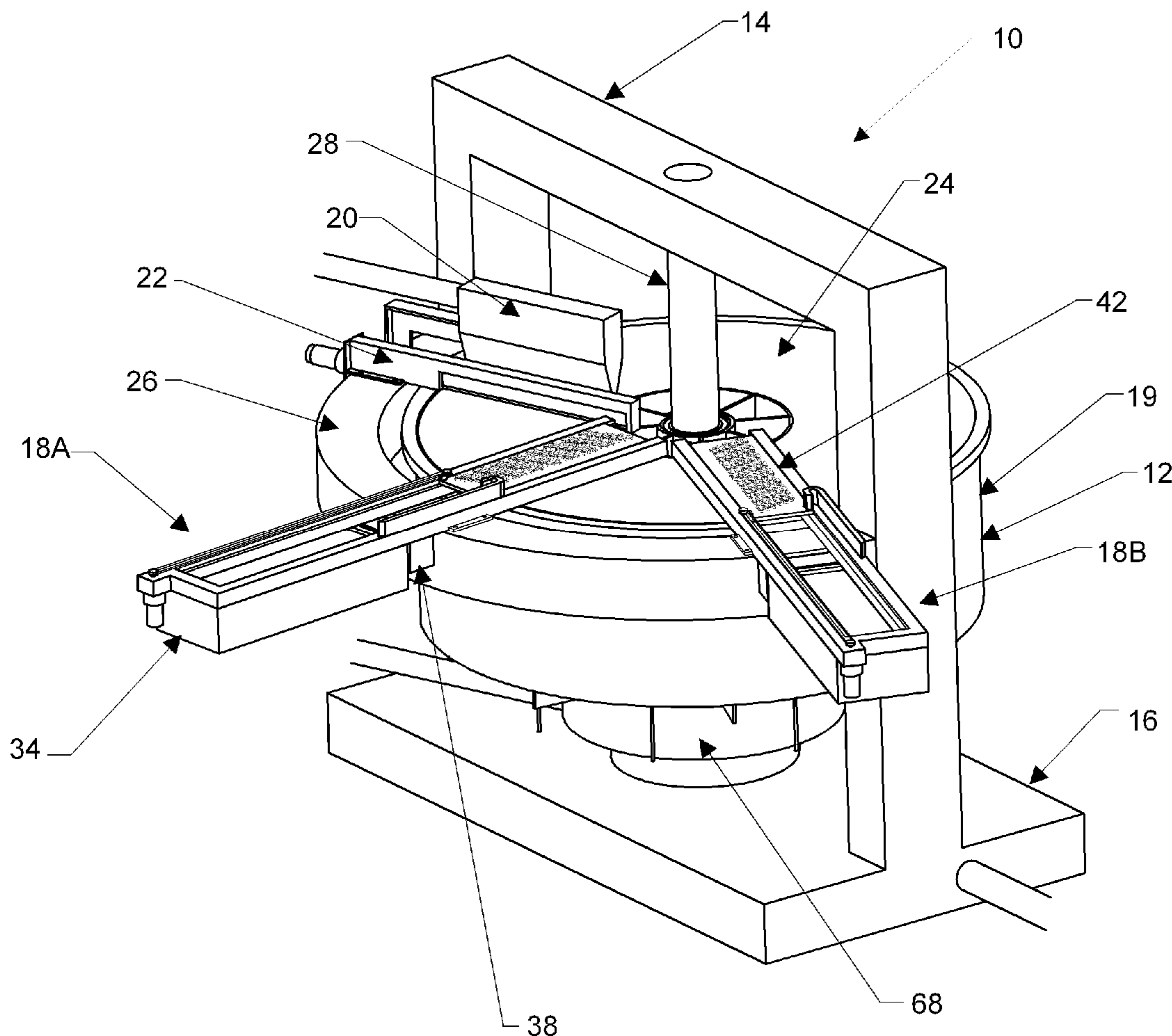

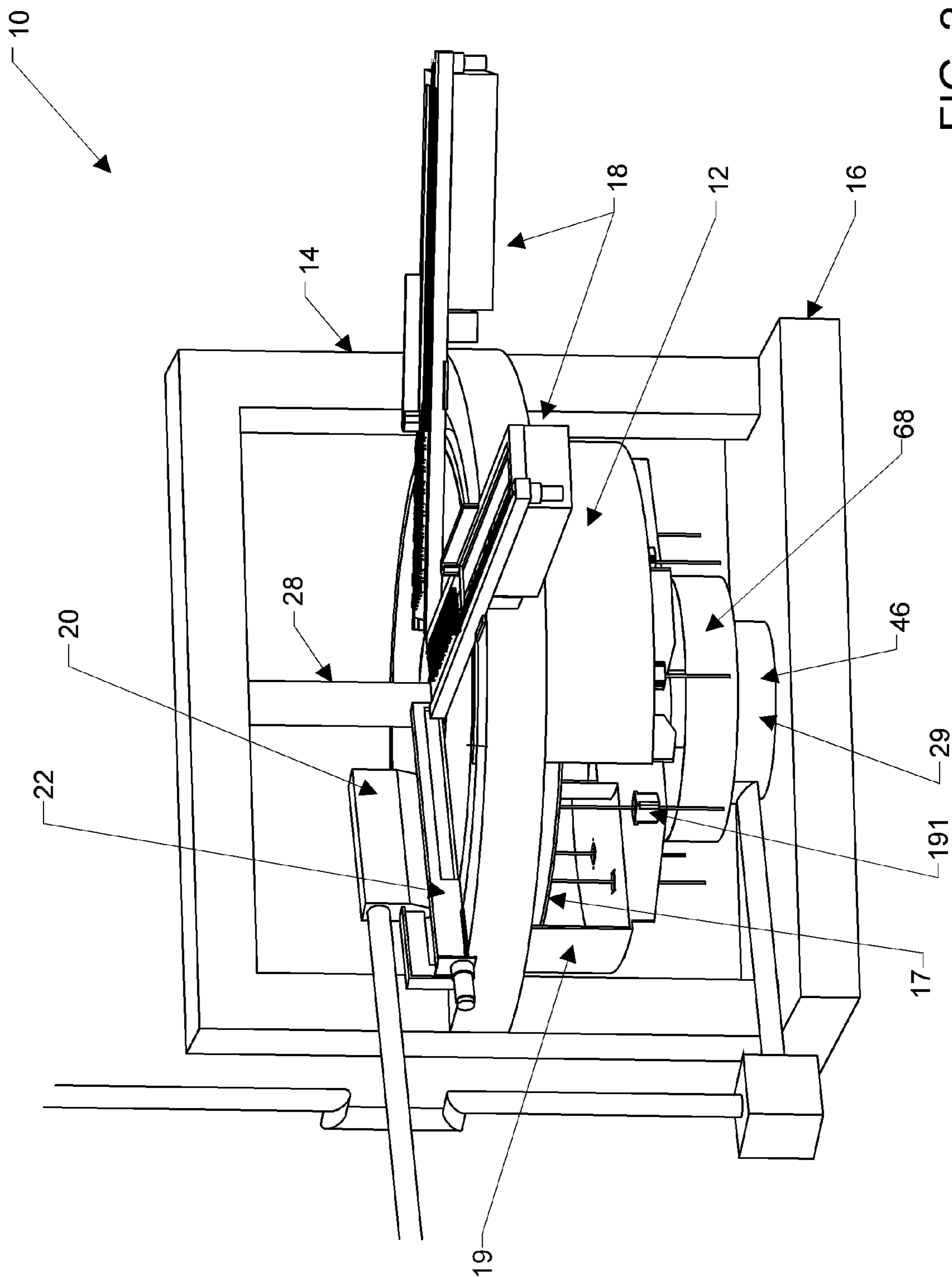

FIG. 2

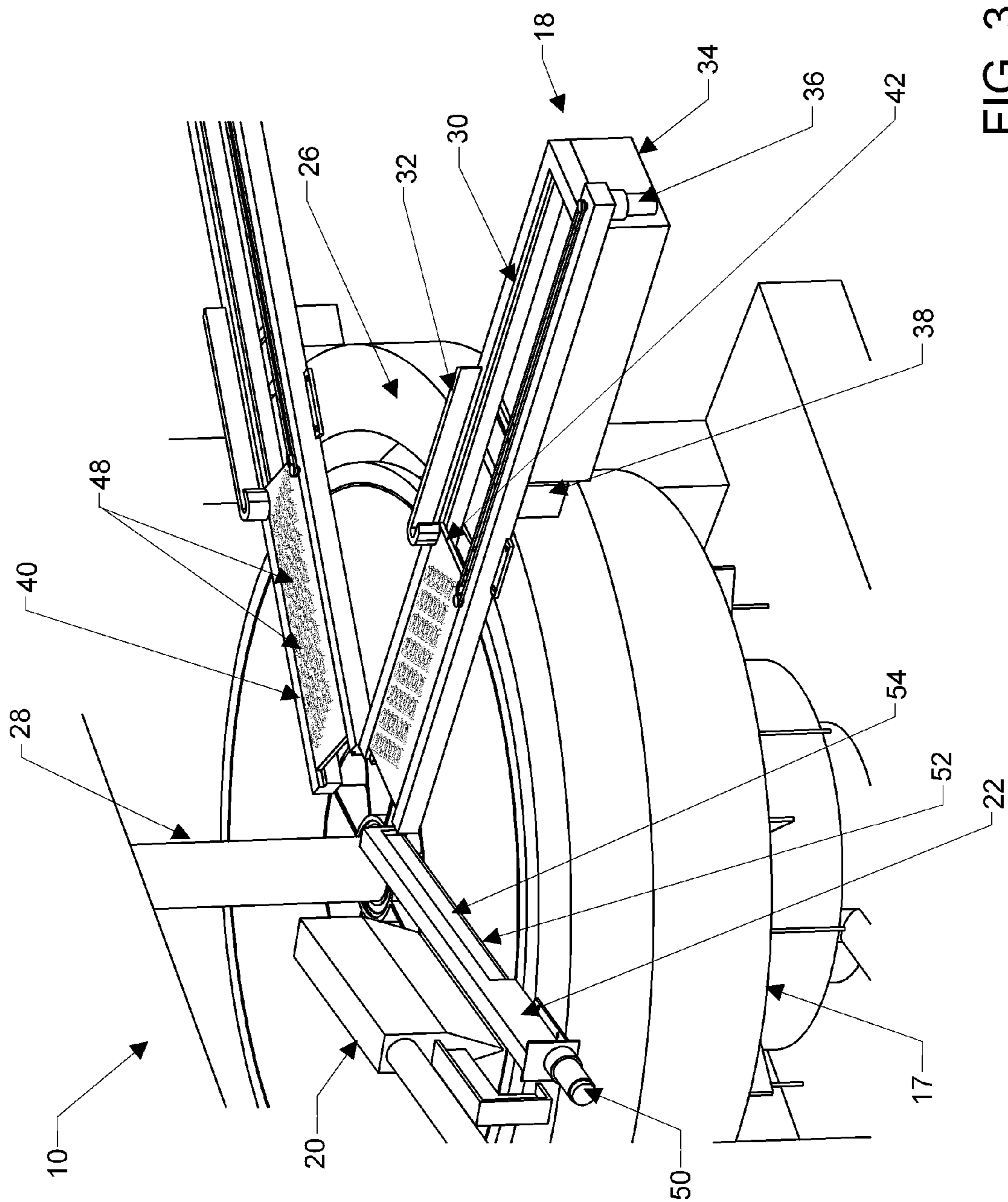

FIG. 3

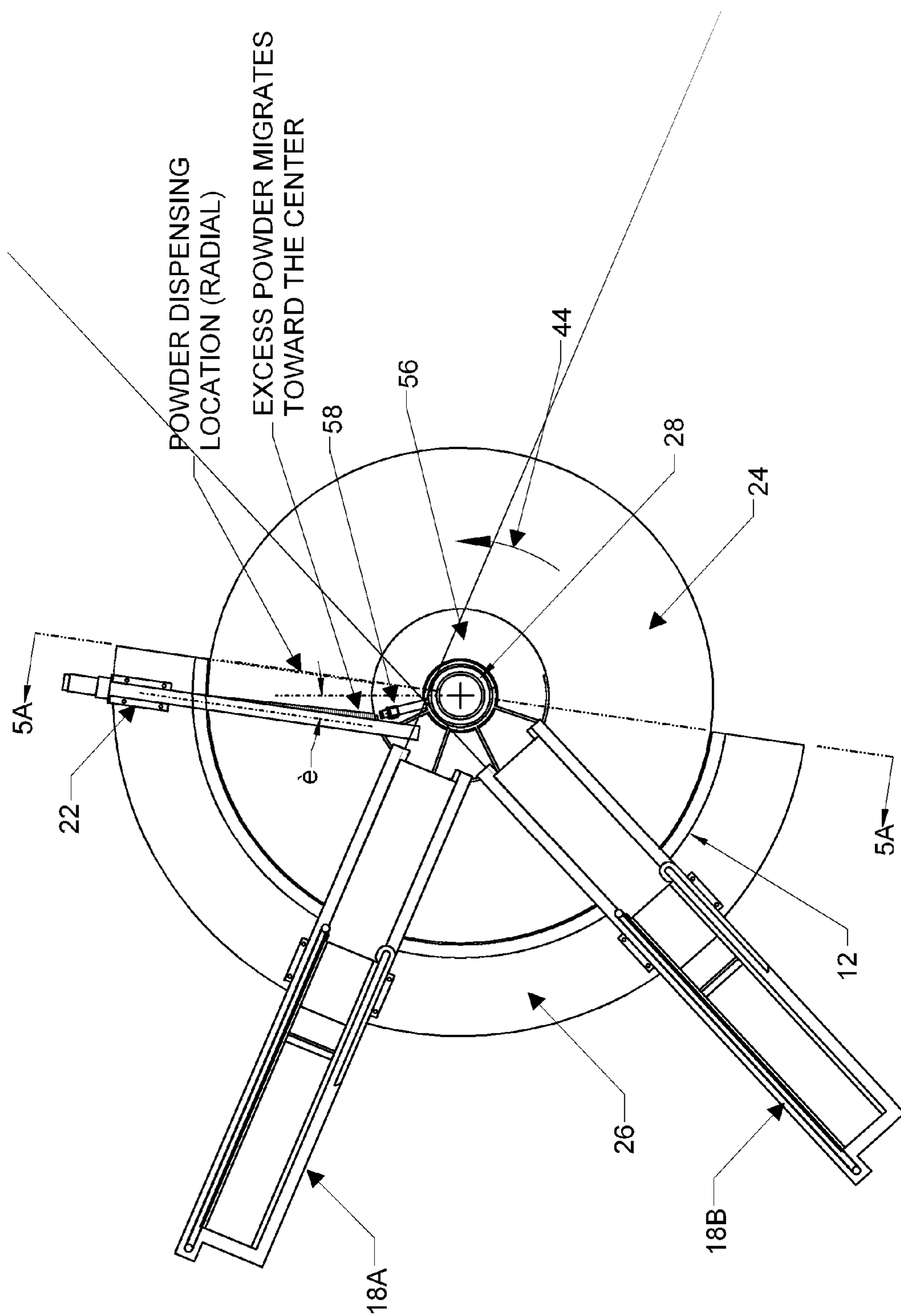
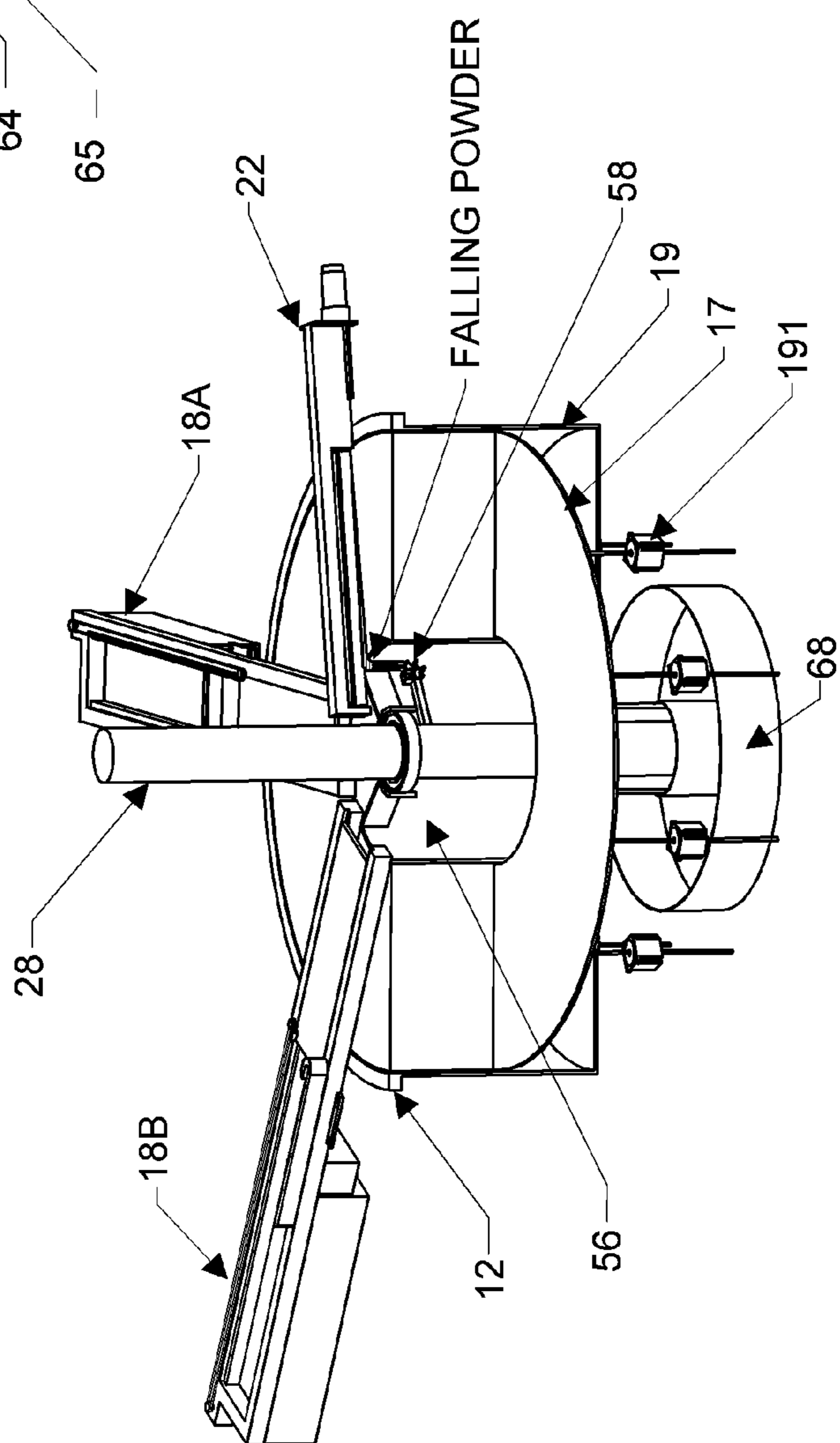
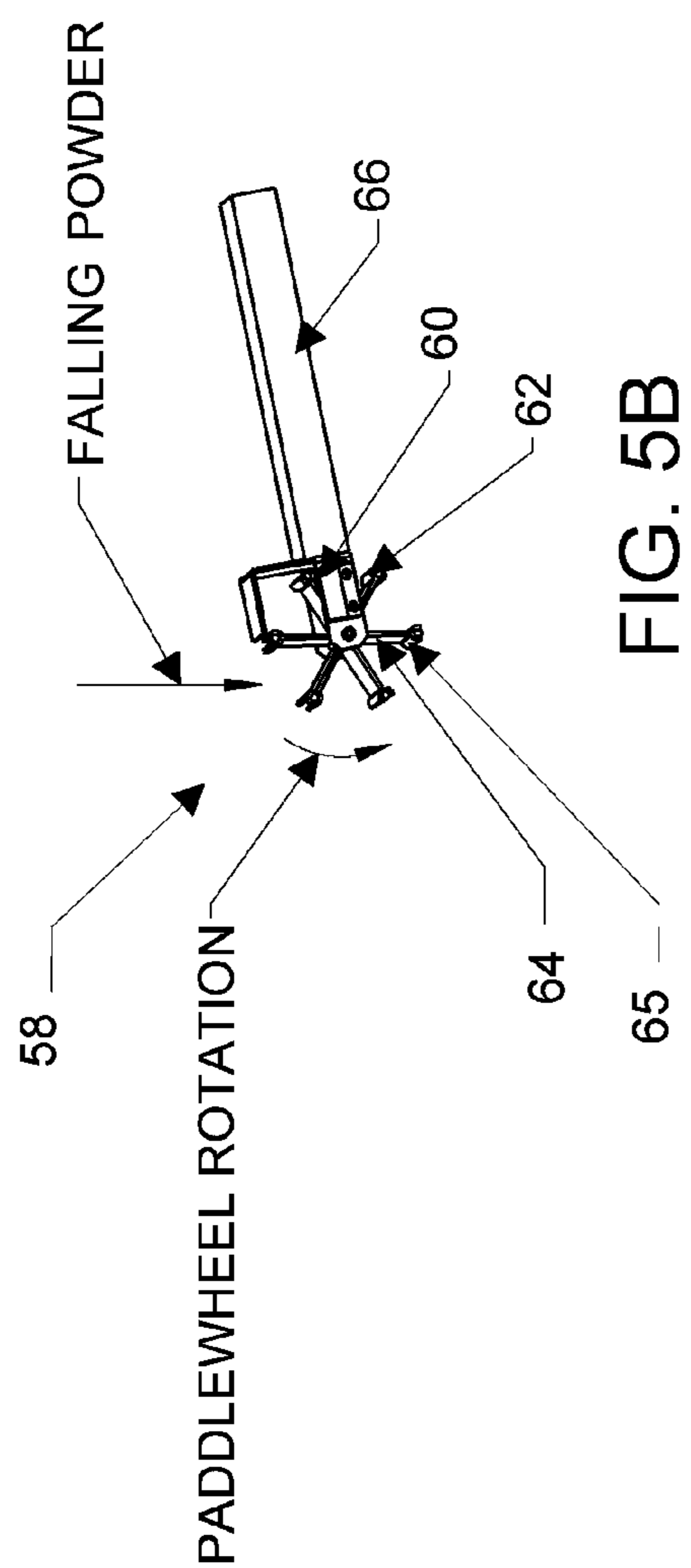

FIG. 4



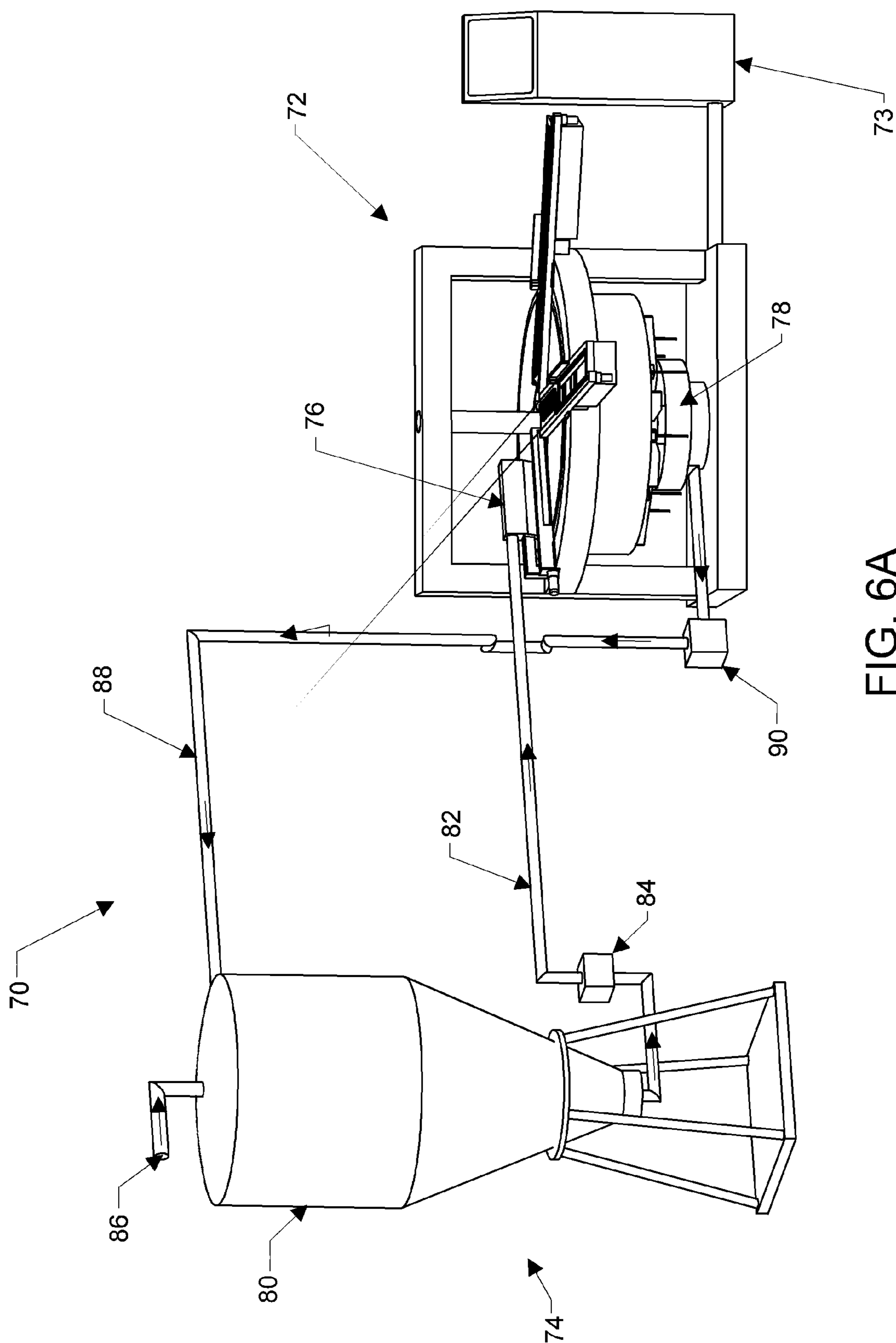

FIG. 6A

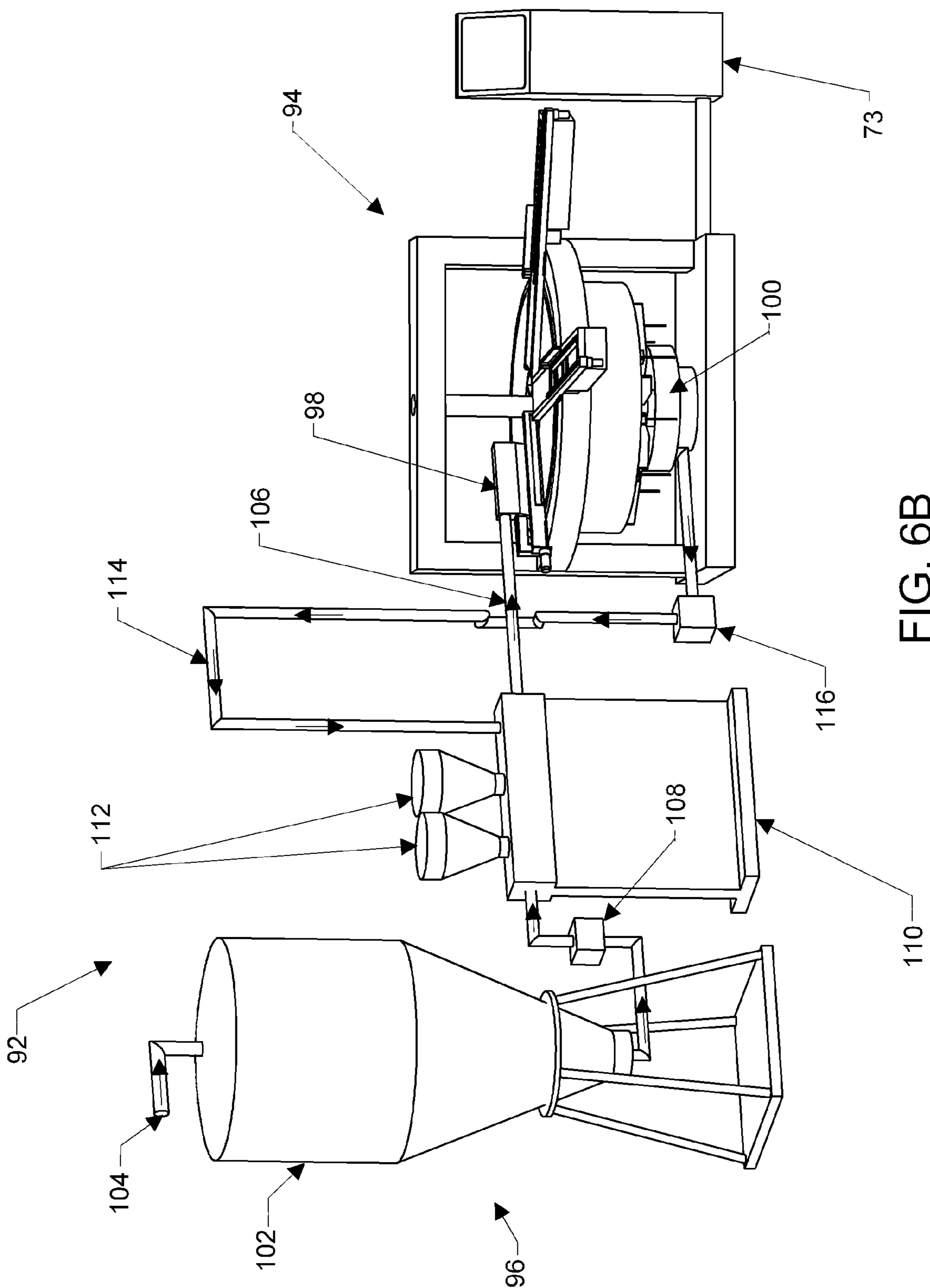

FIG. 6B

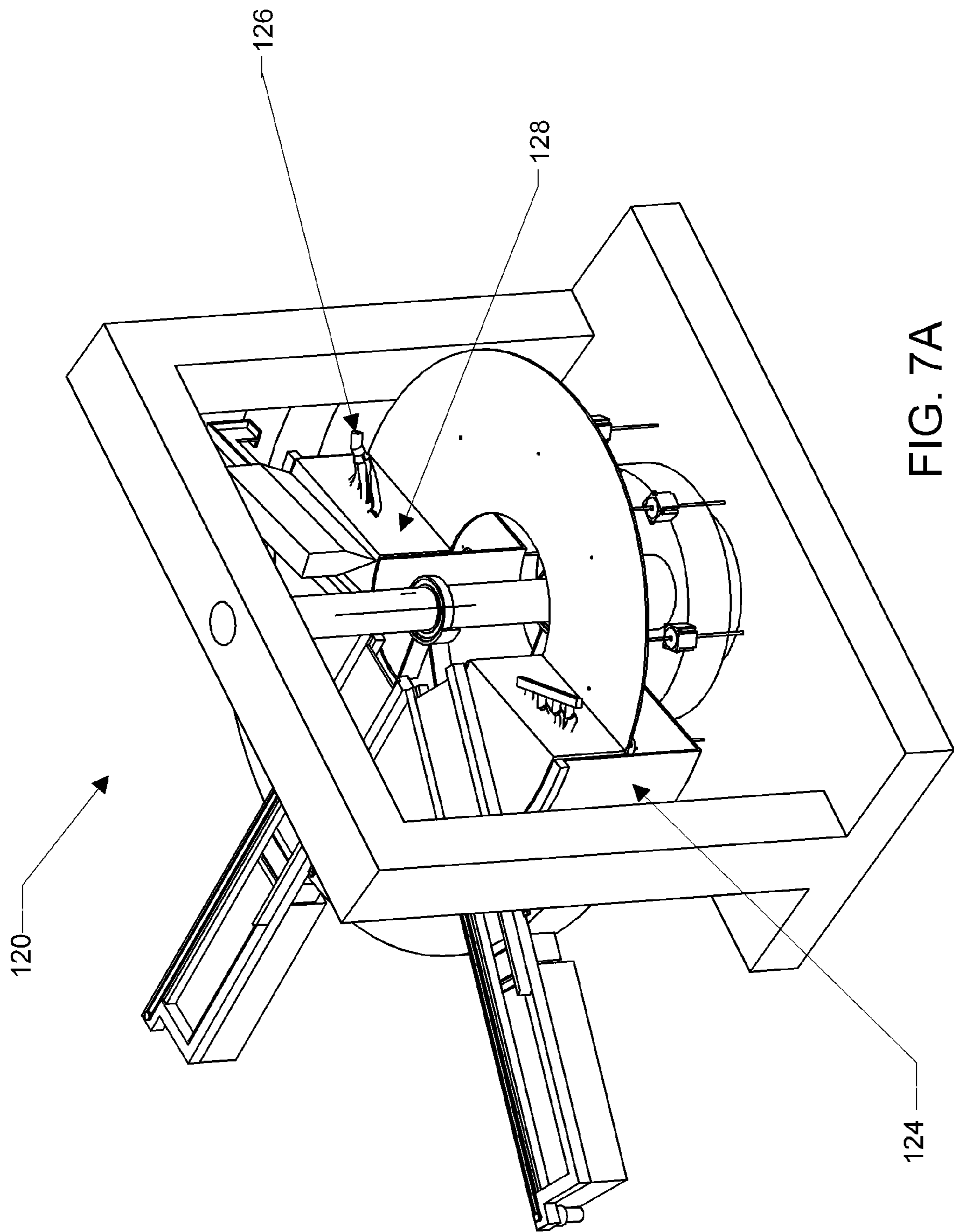

FIG. 7A

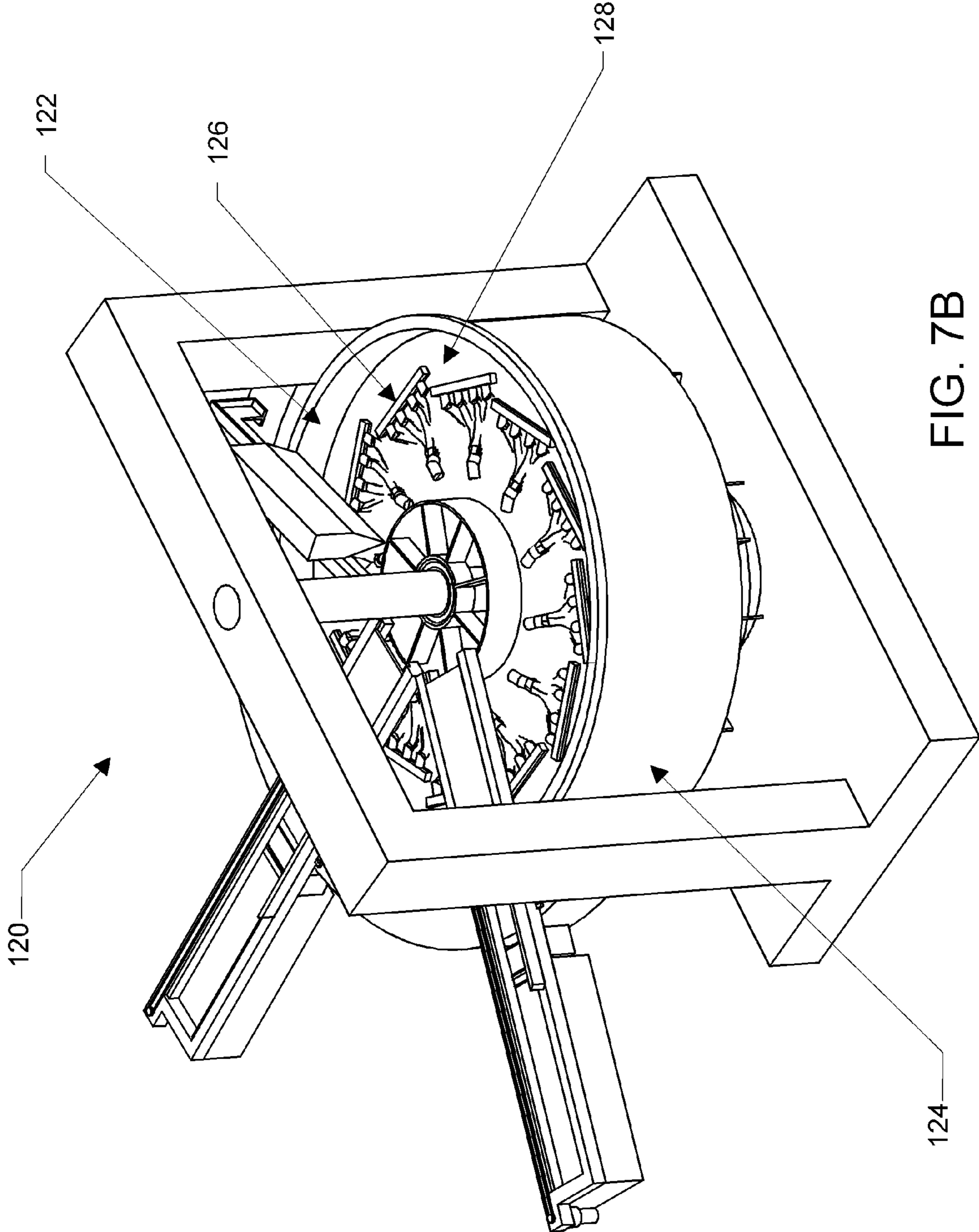

FIG. 7B

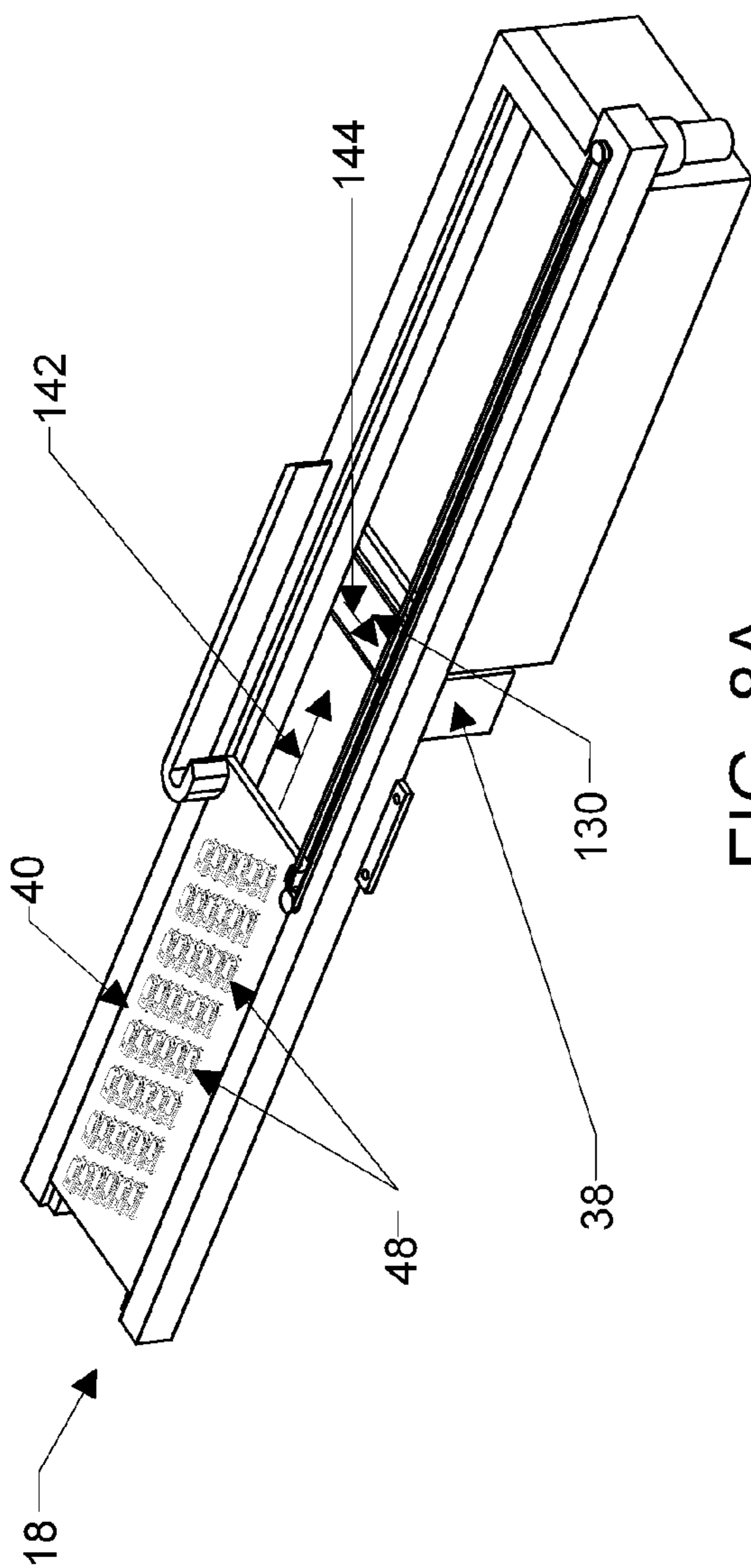

FIG. 8A

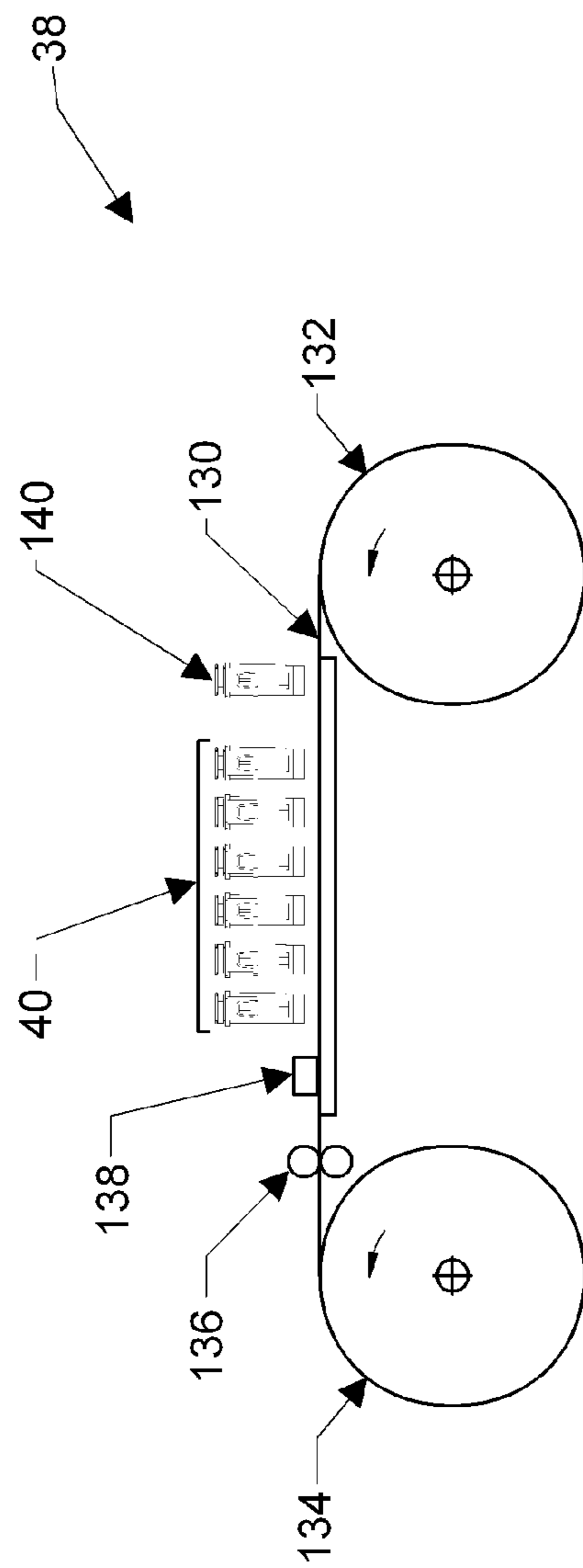
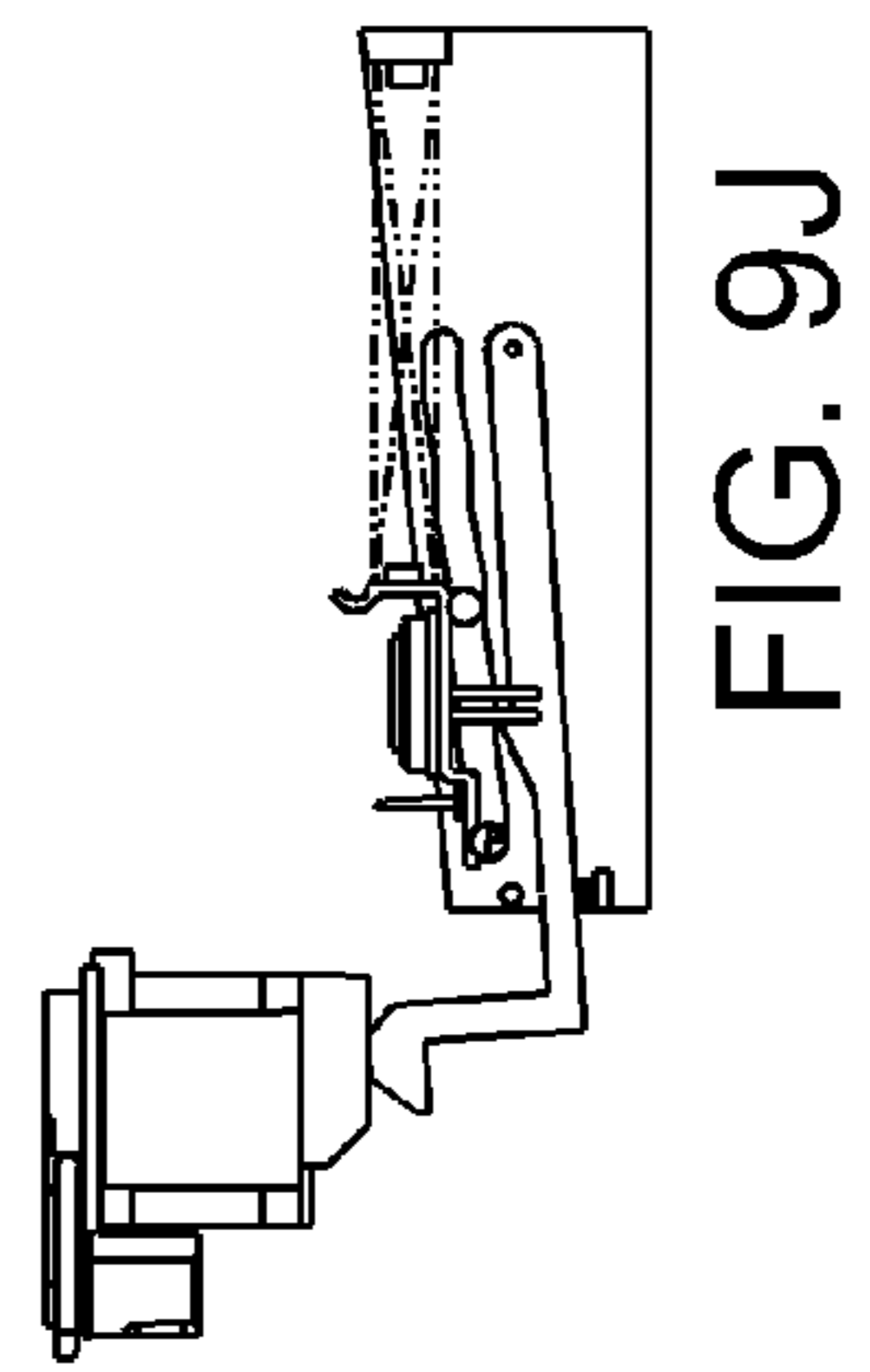
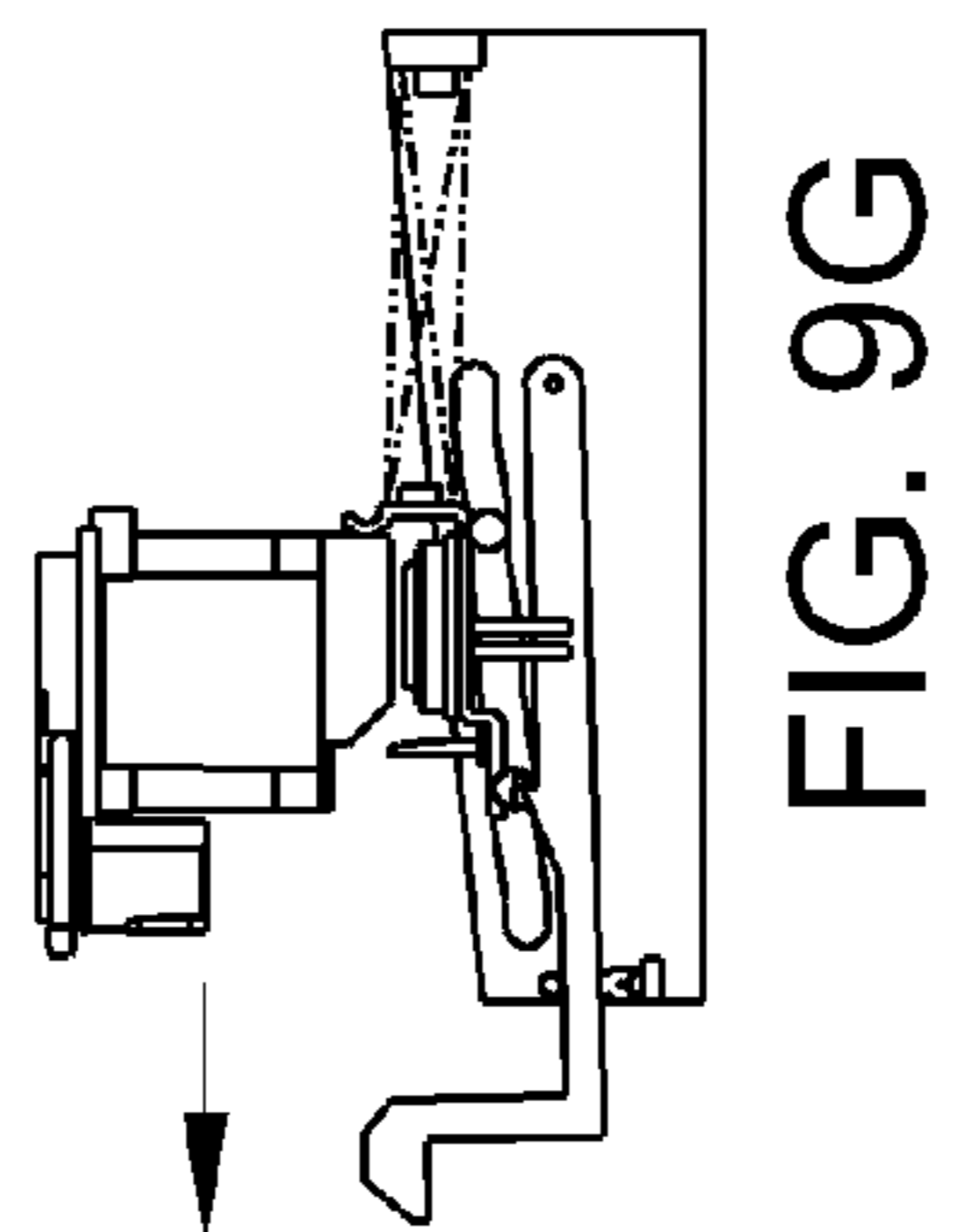
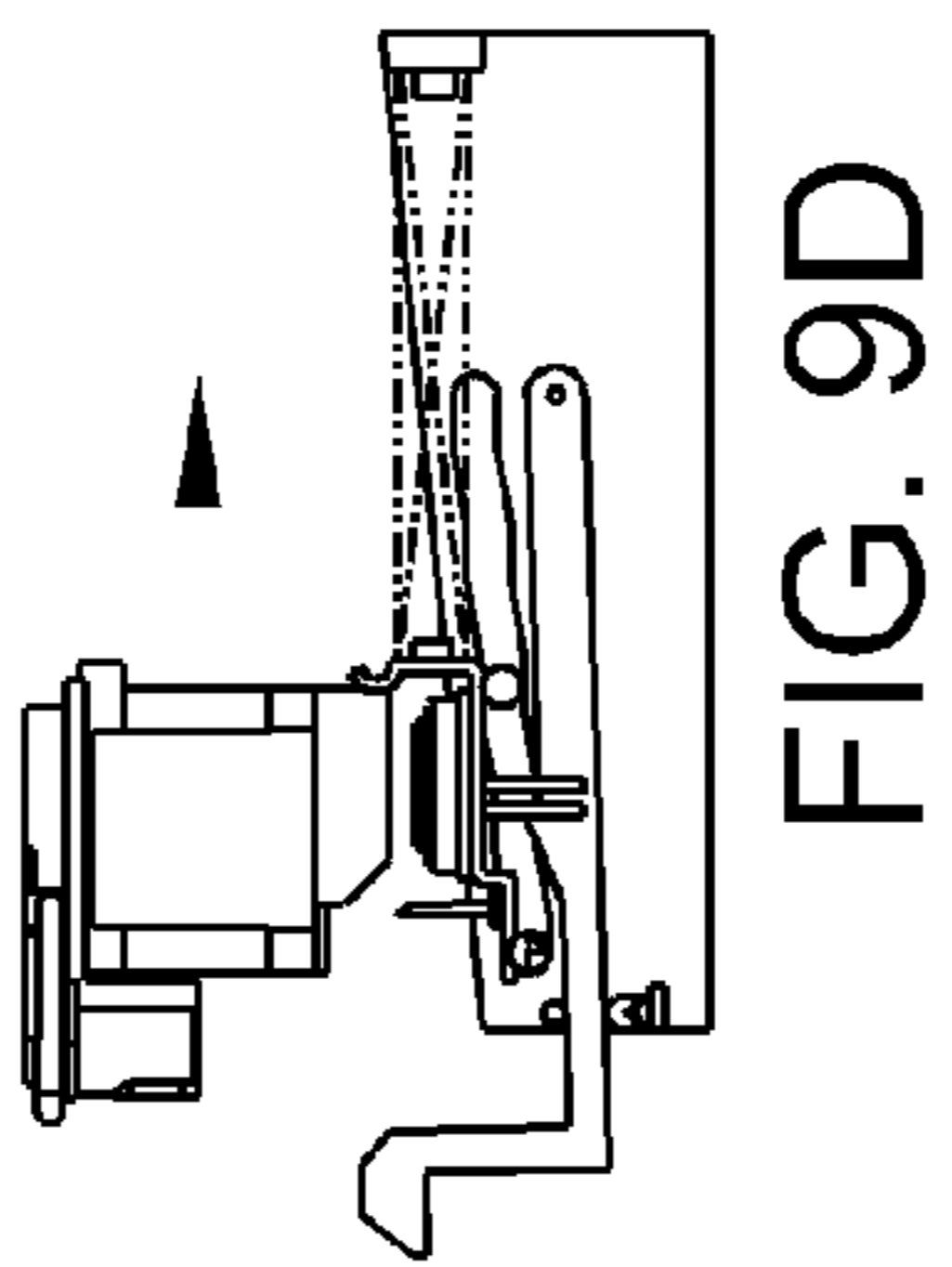
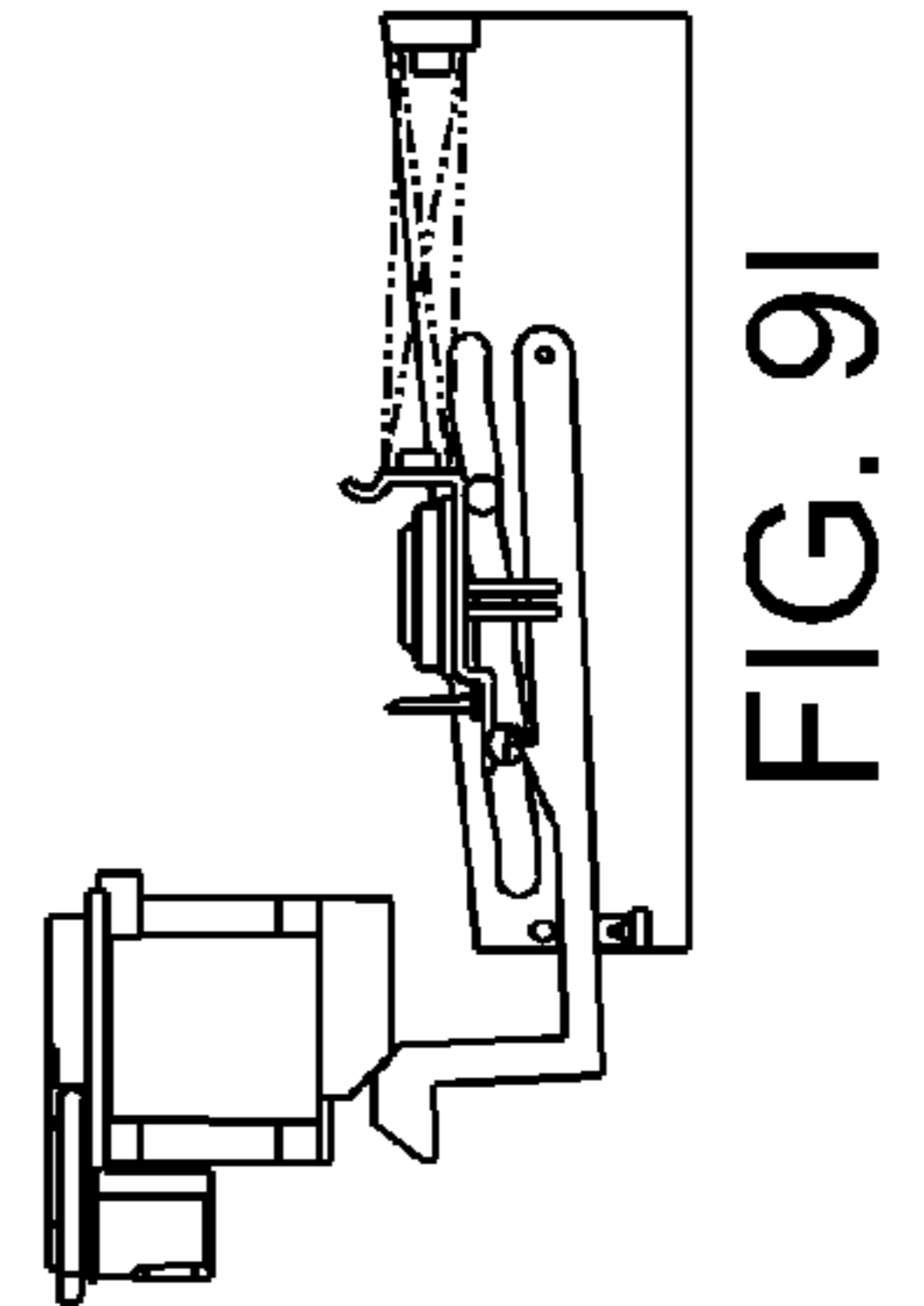
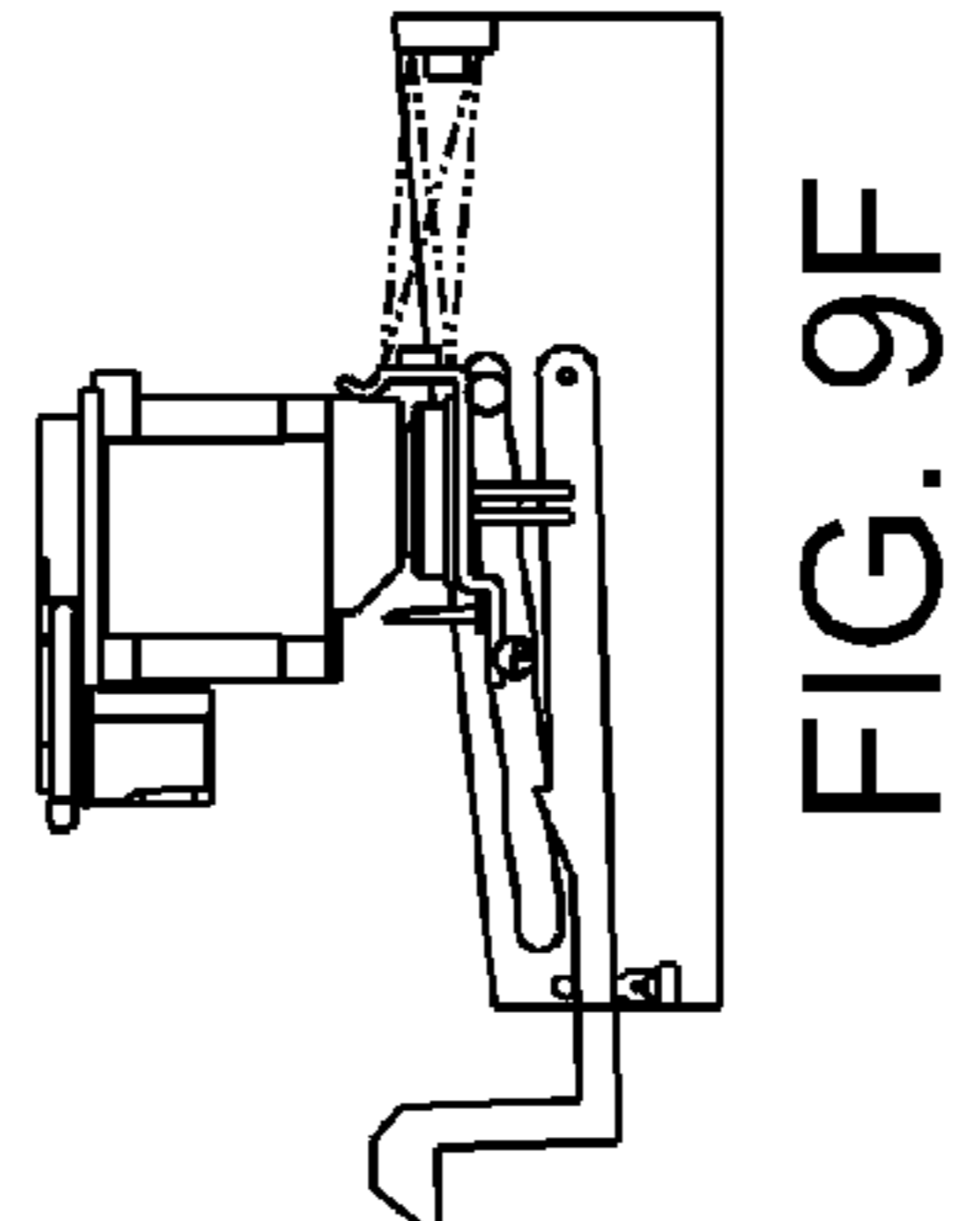
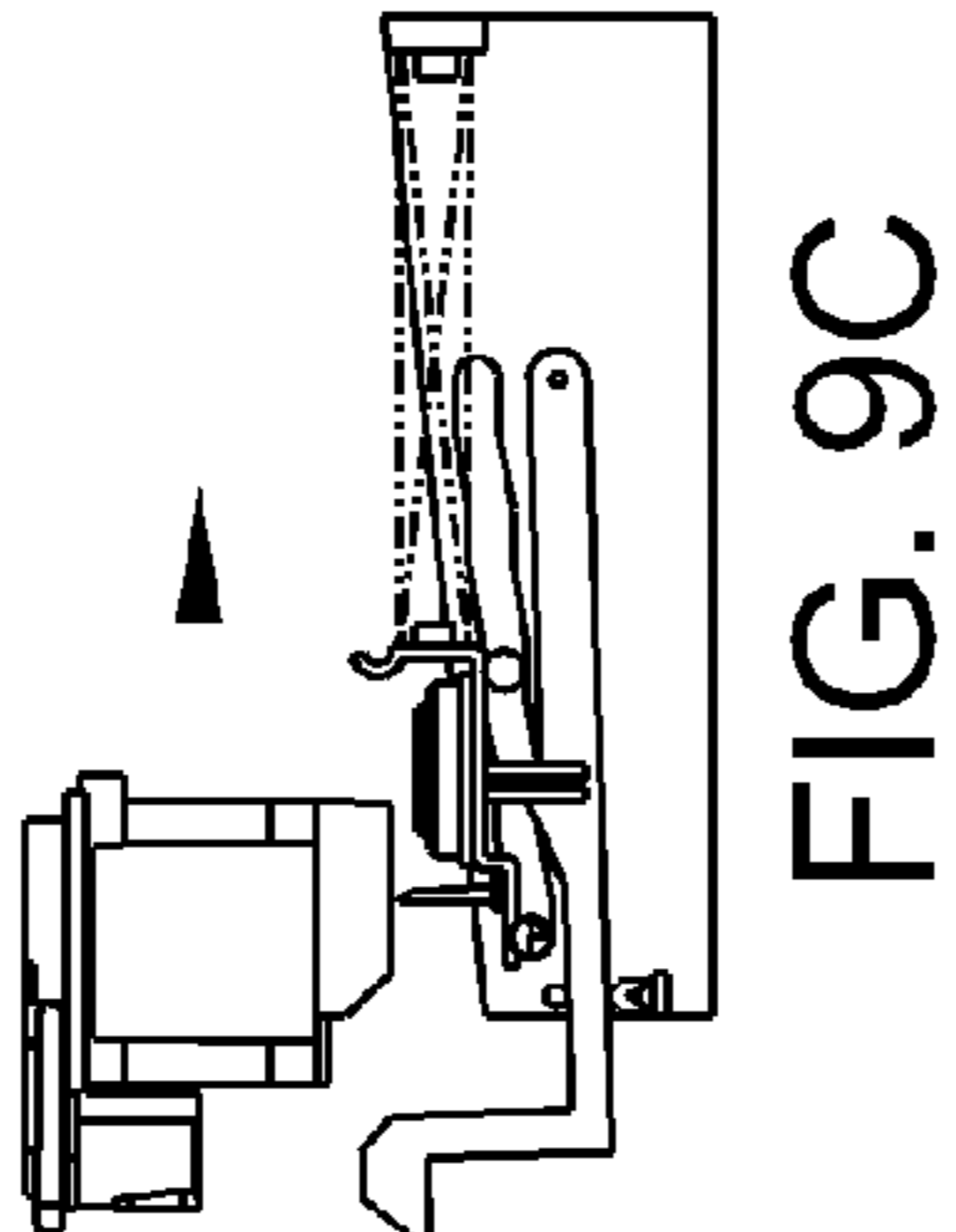
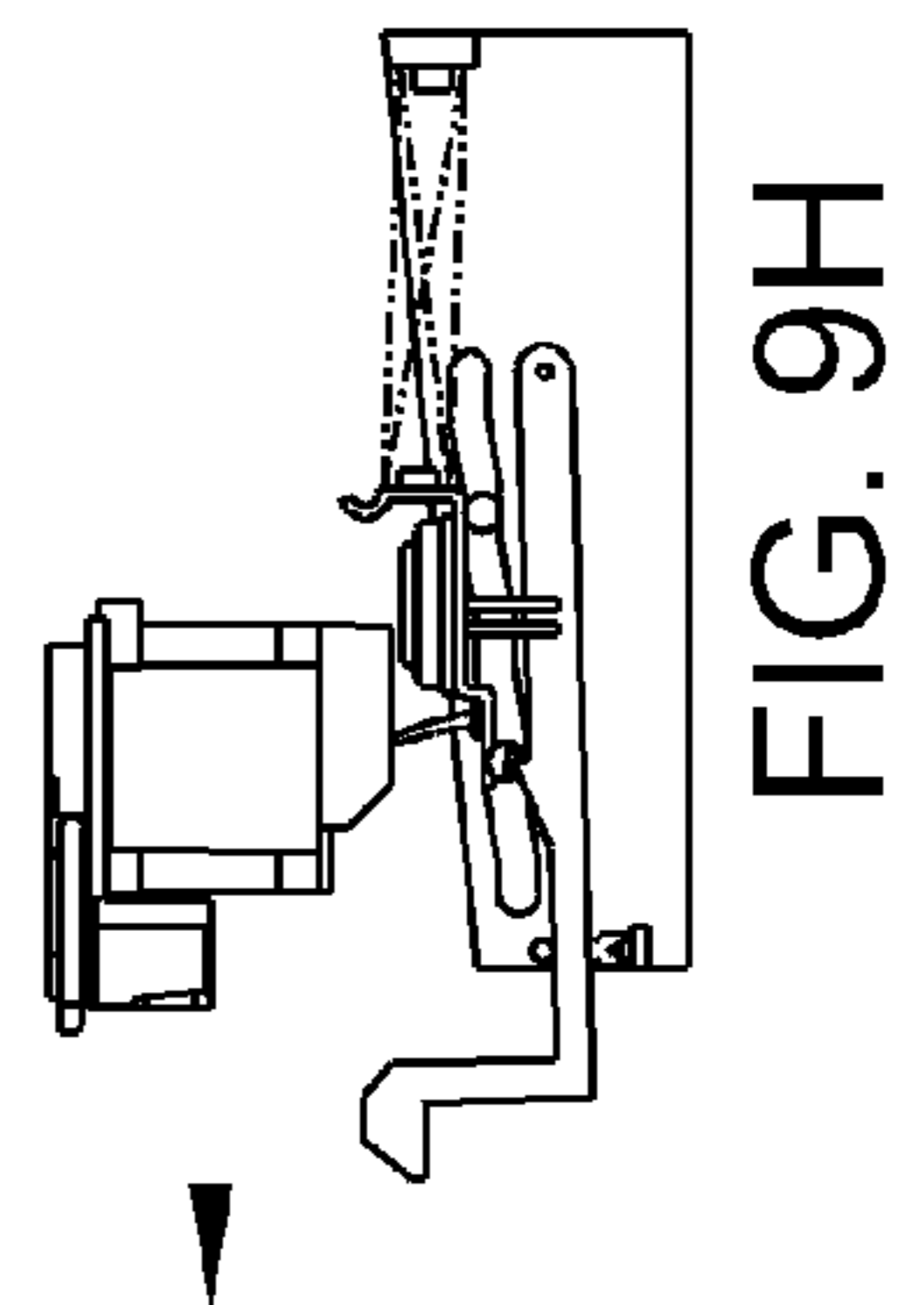
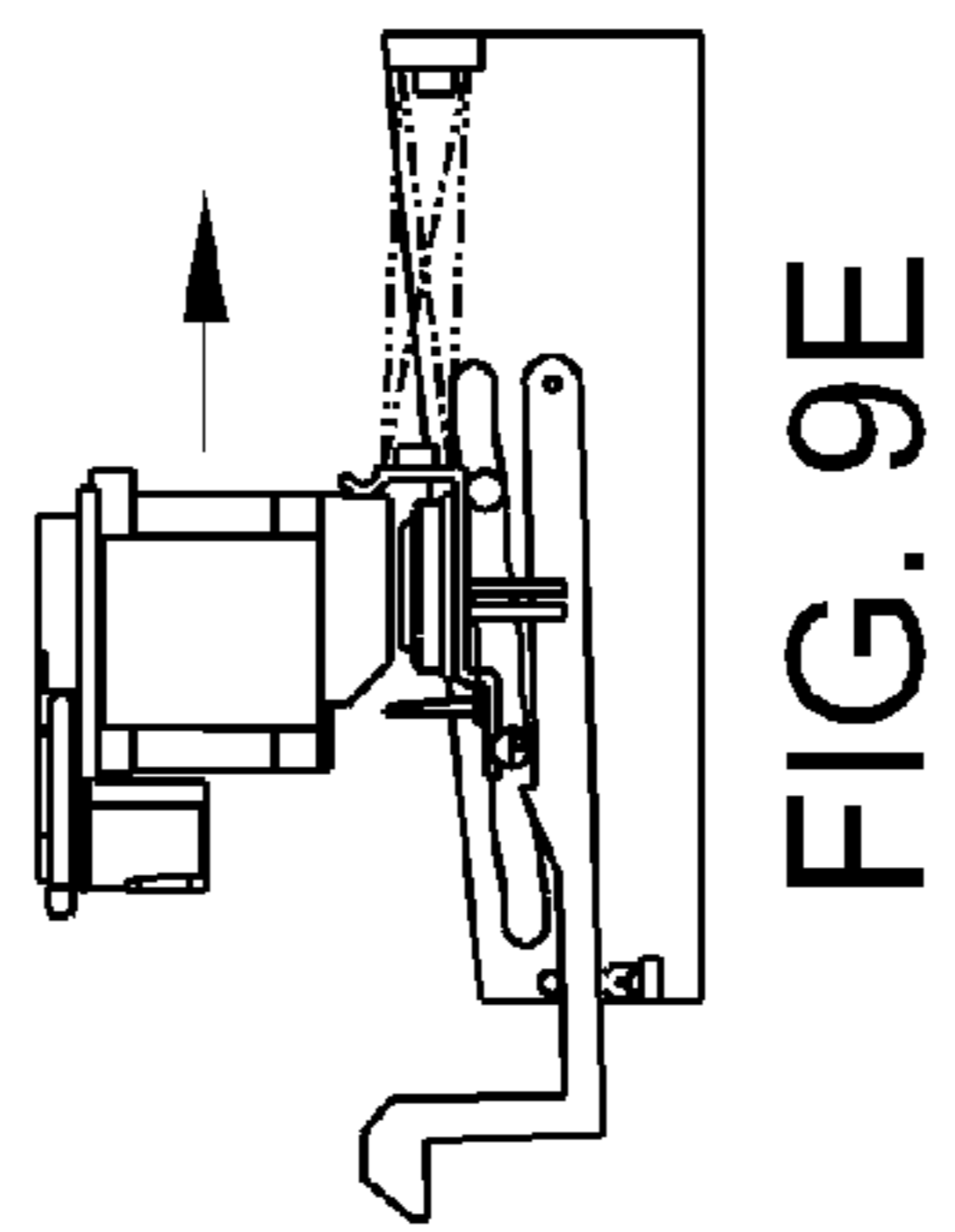
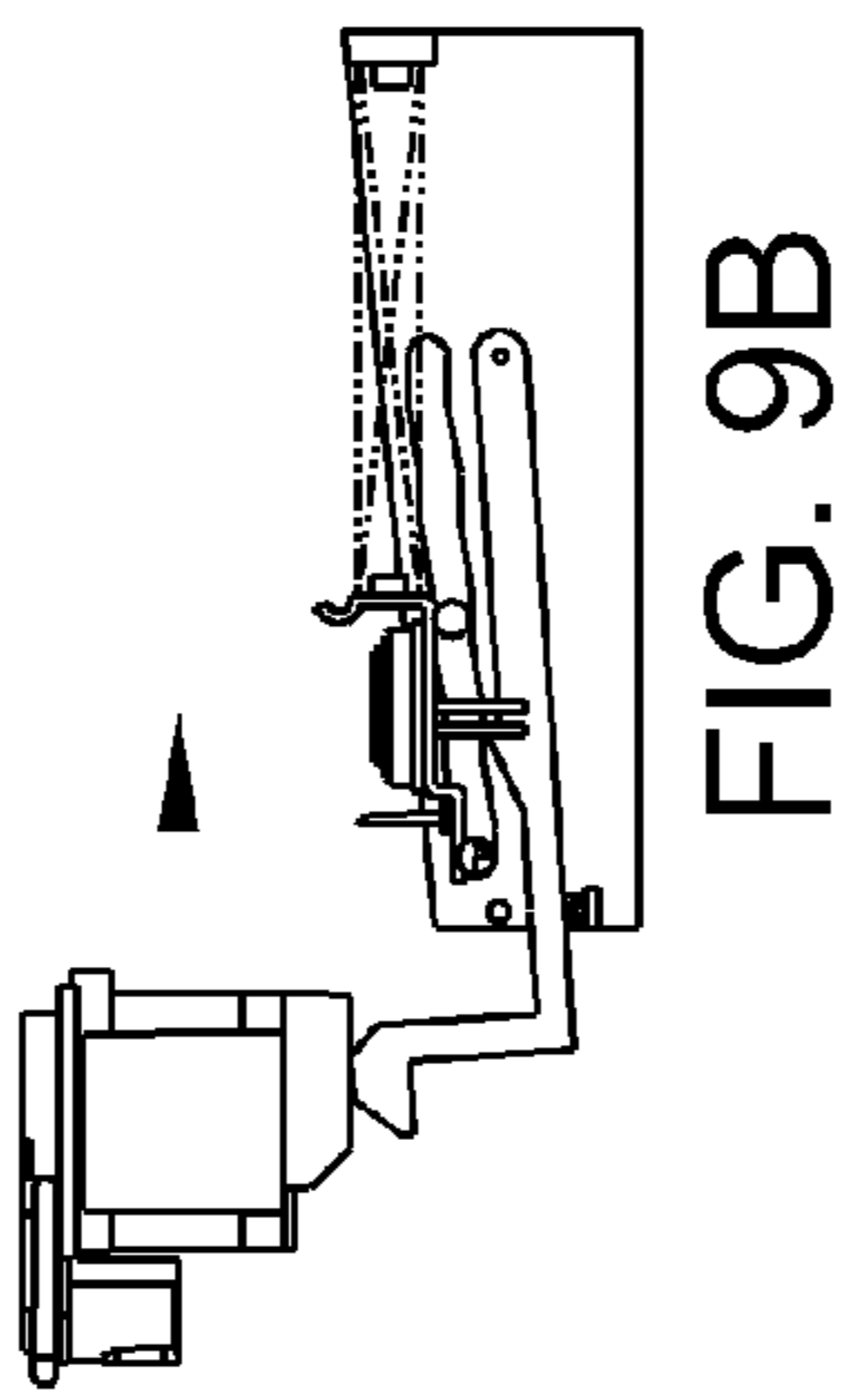
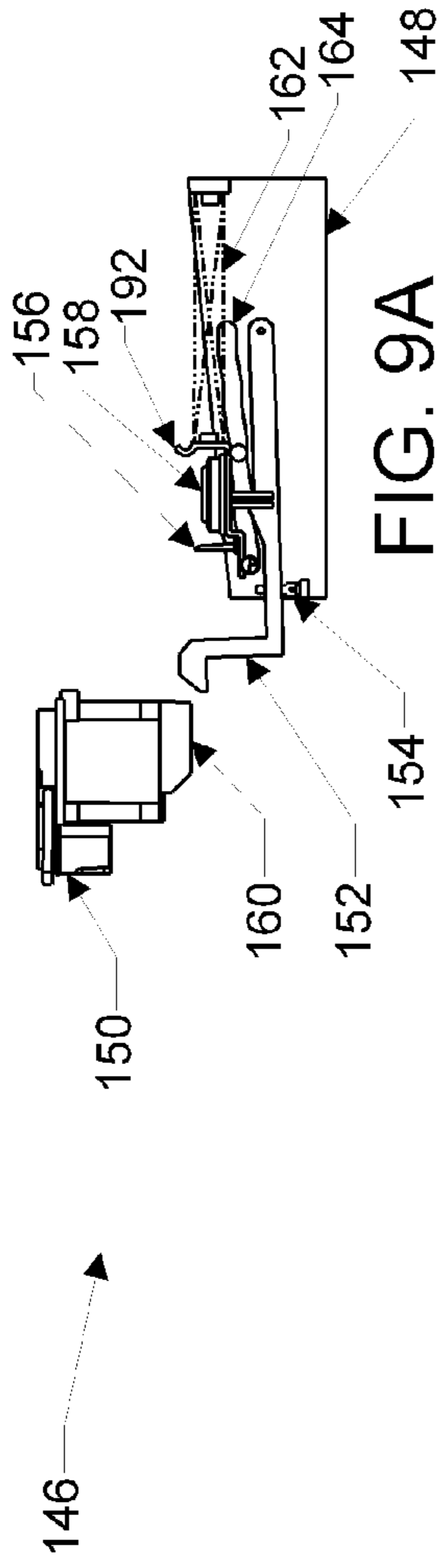

FIG. 8B



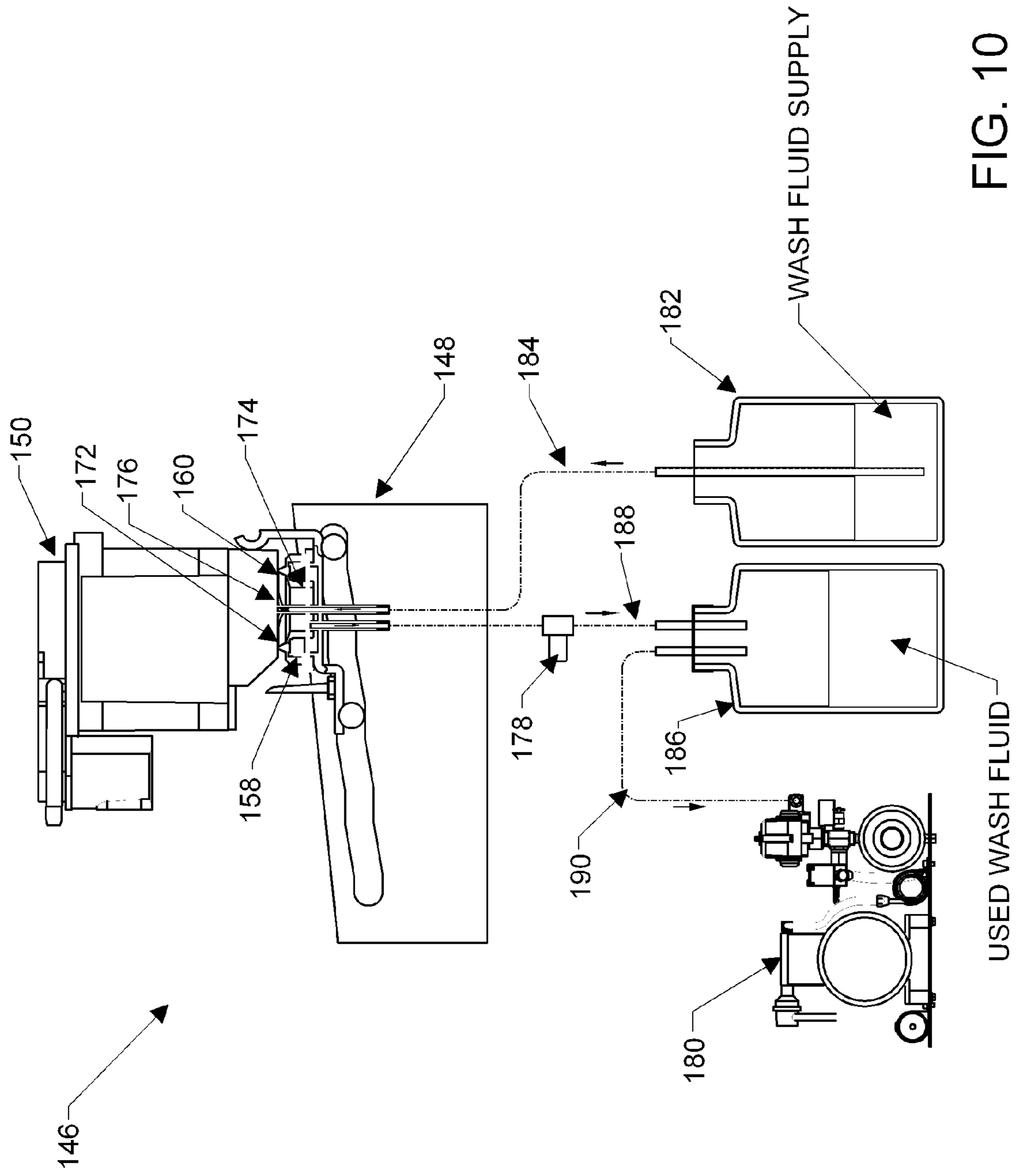

FIG. 10

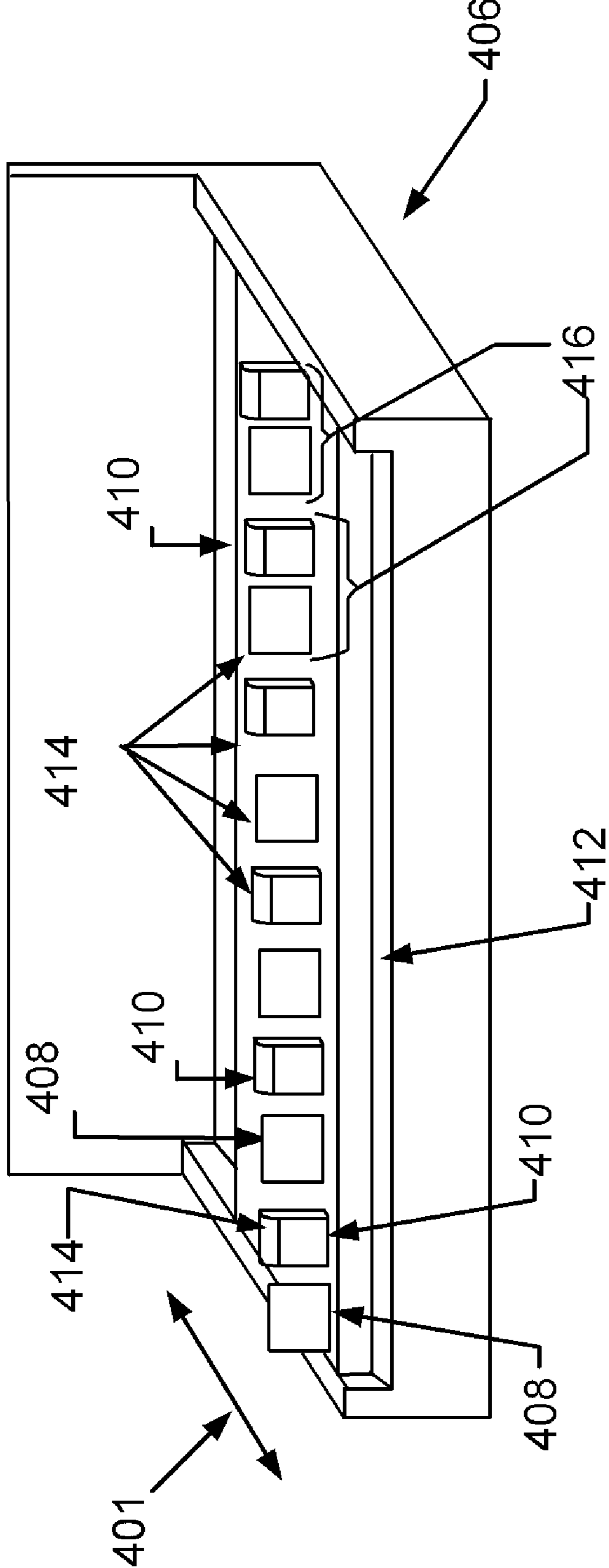

FIG. 11

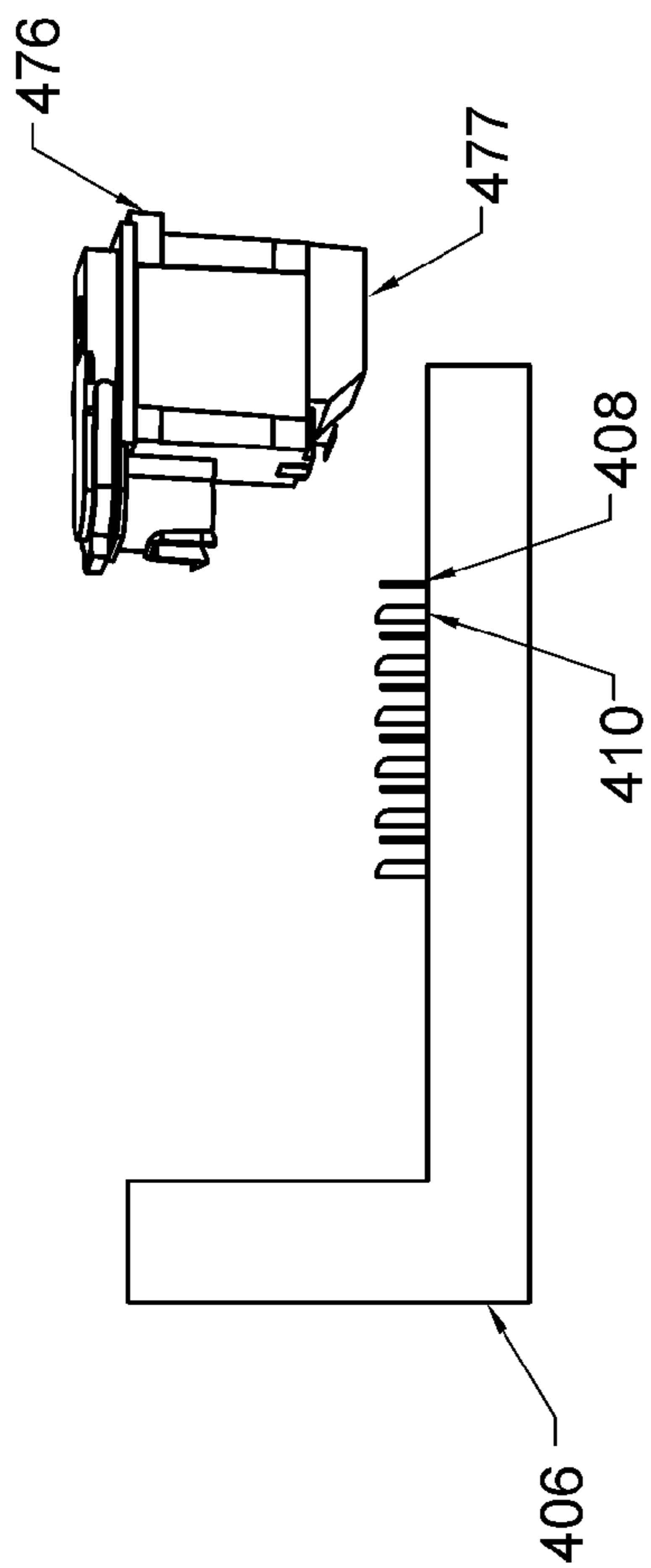

FIG. 12A

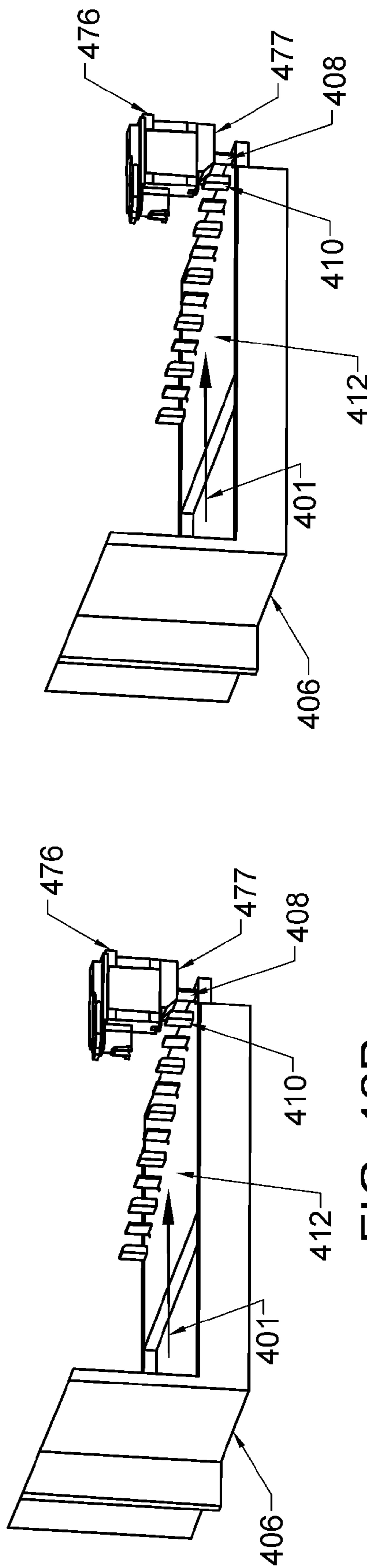

FIG. 12B

FIG. 12C

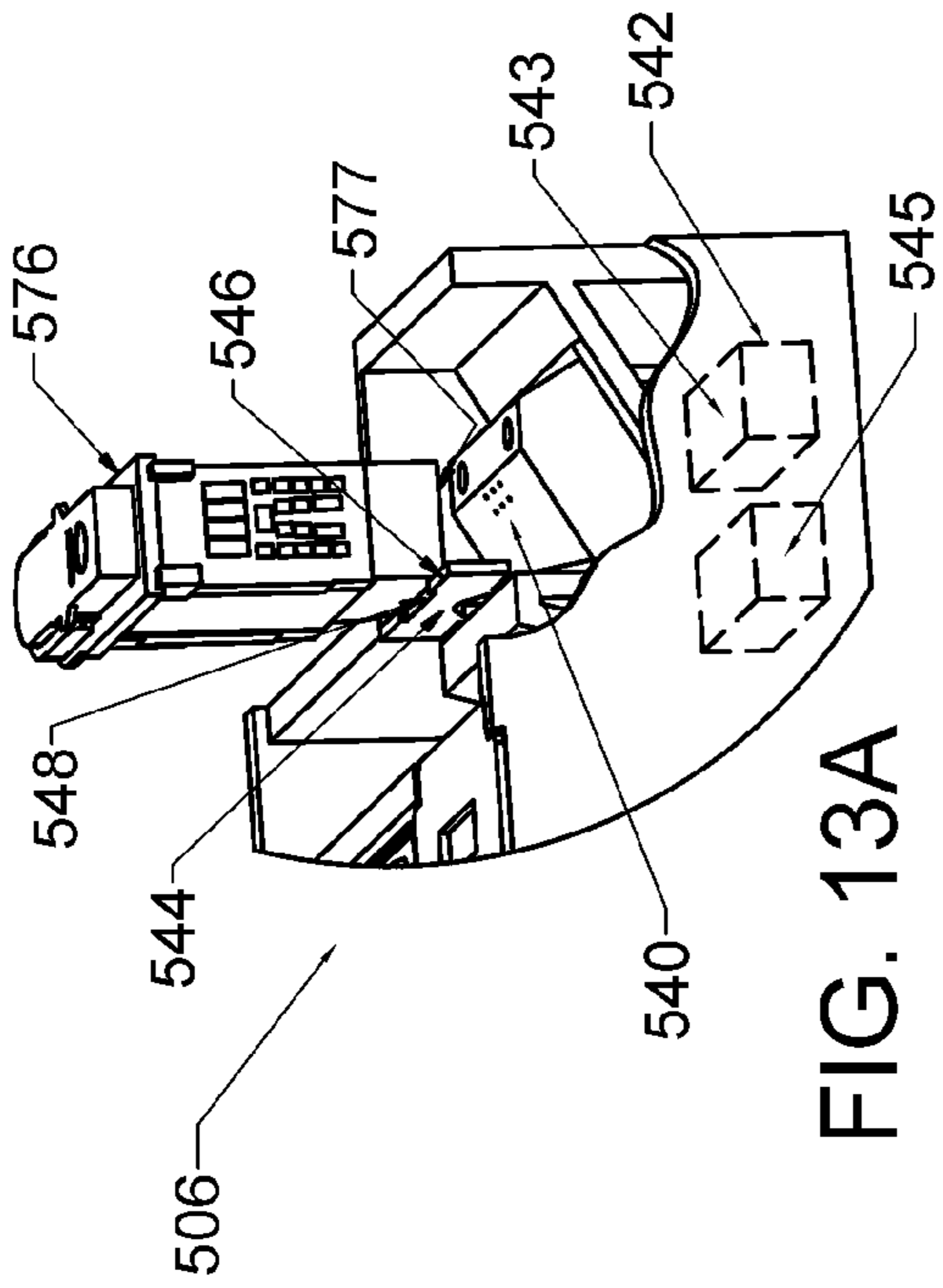

FIG. 13A

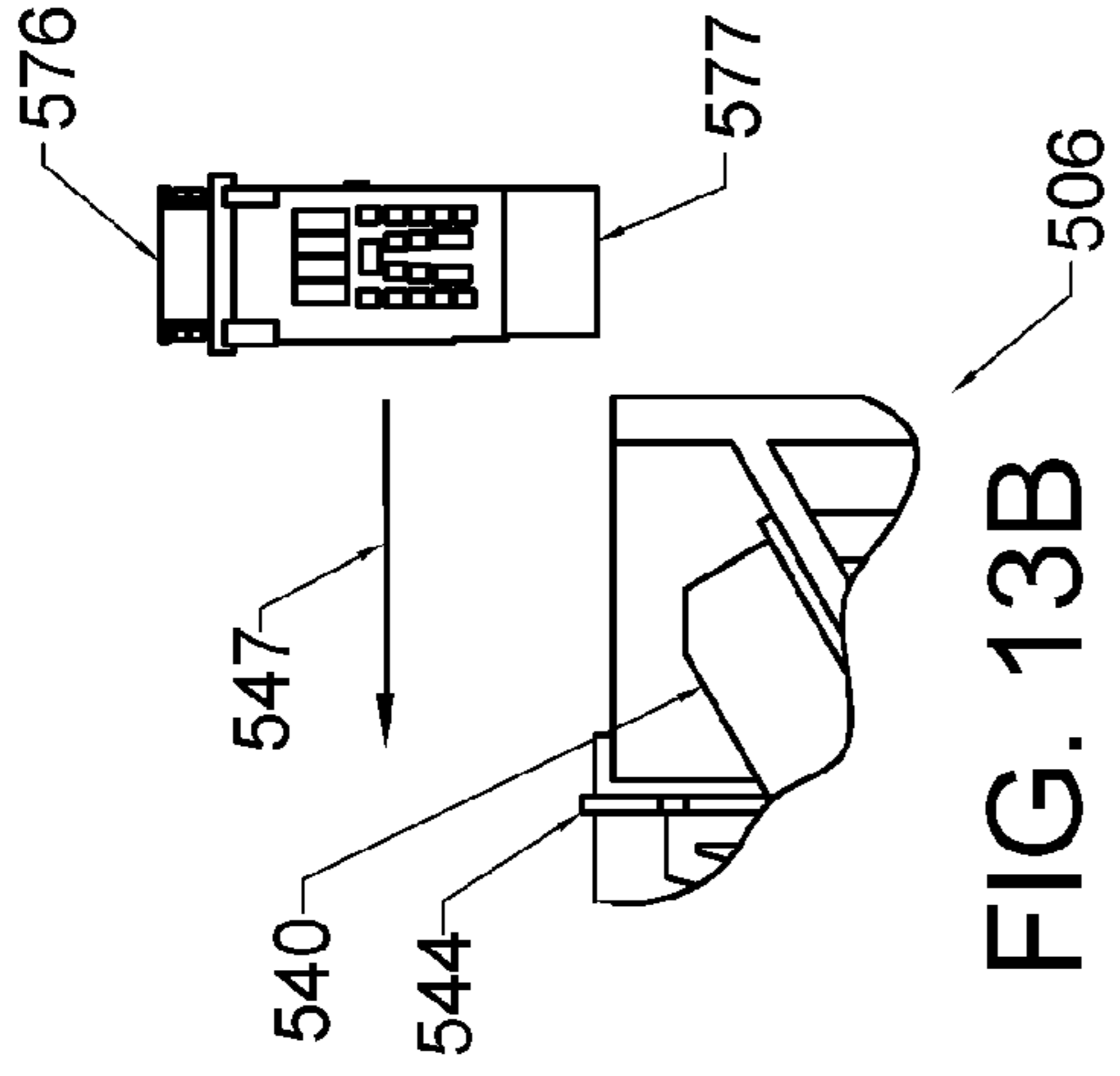

FIG. 13B

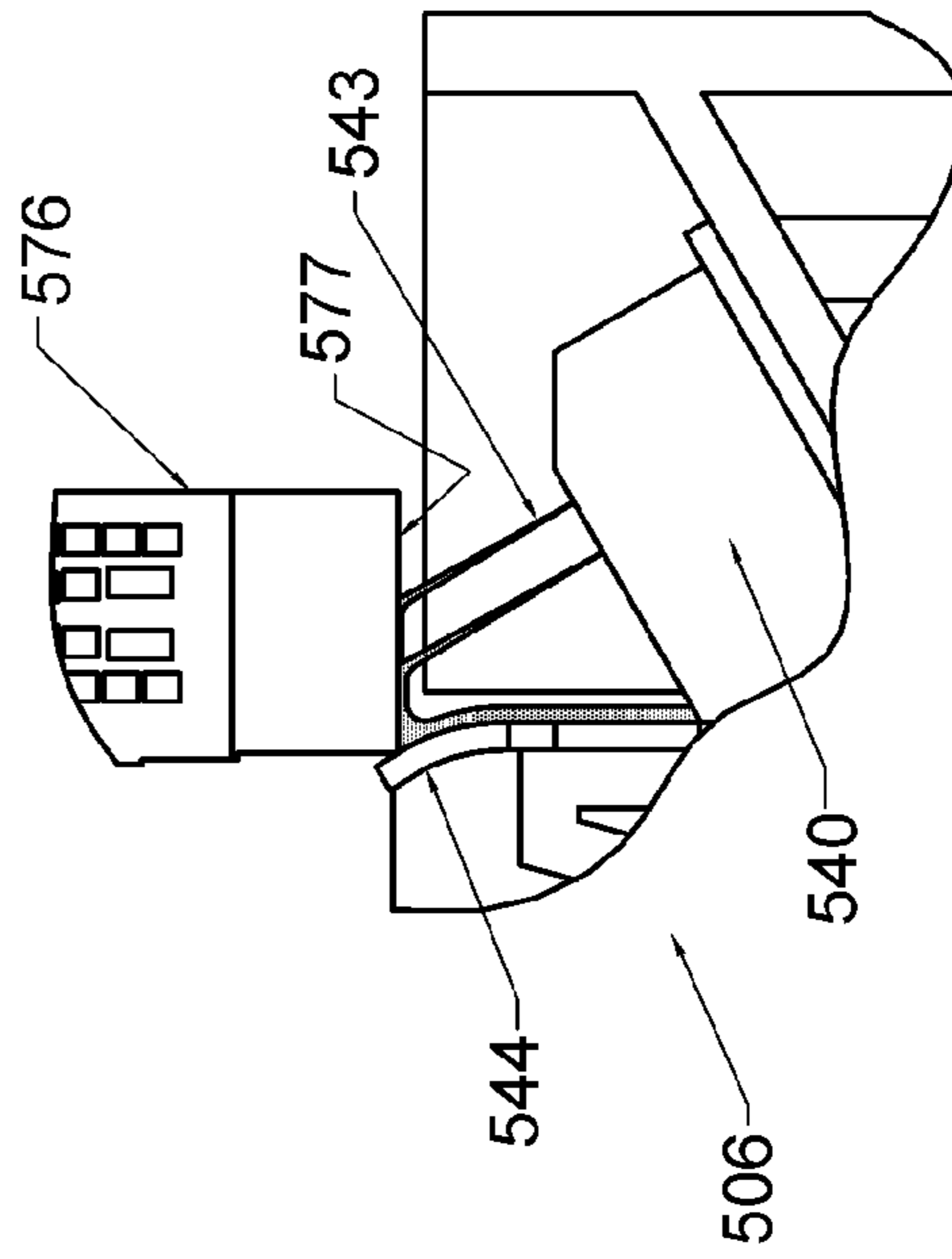

FIG. 13C

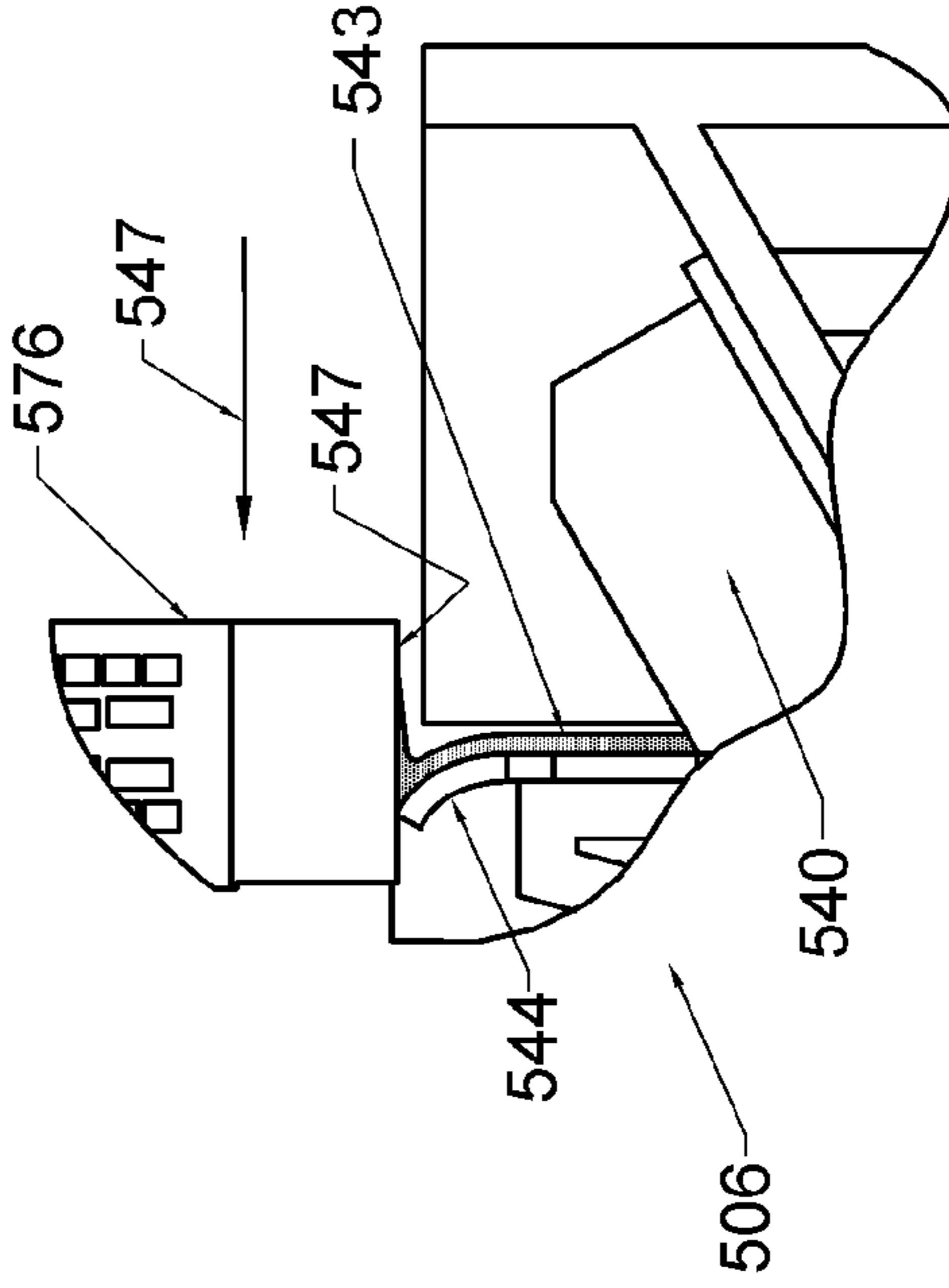

FIG. 13D

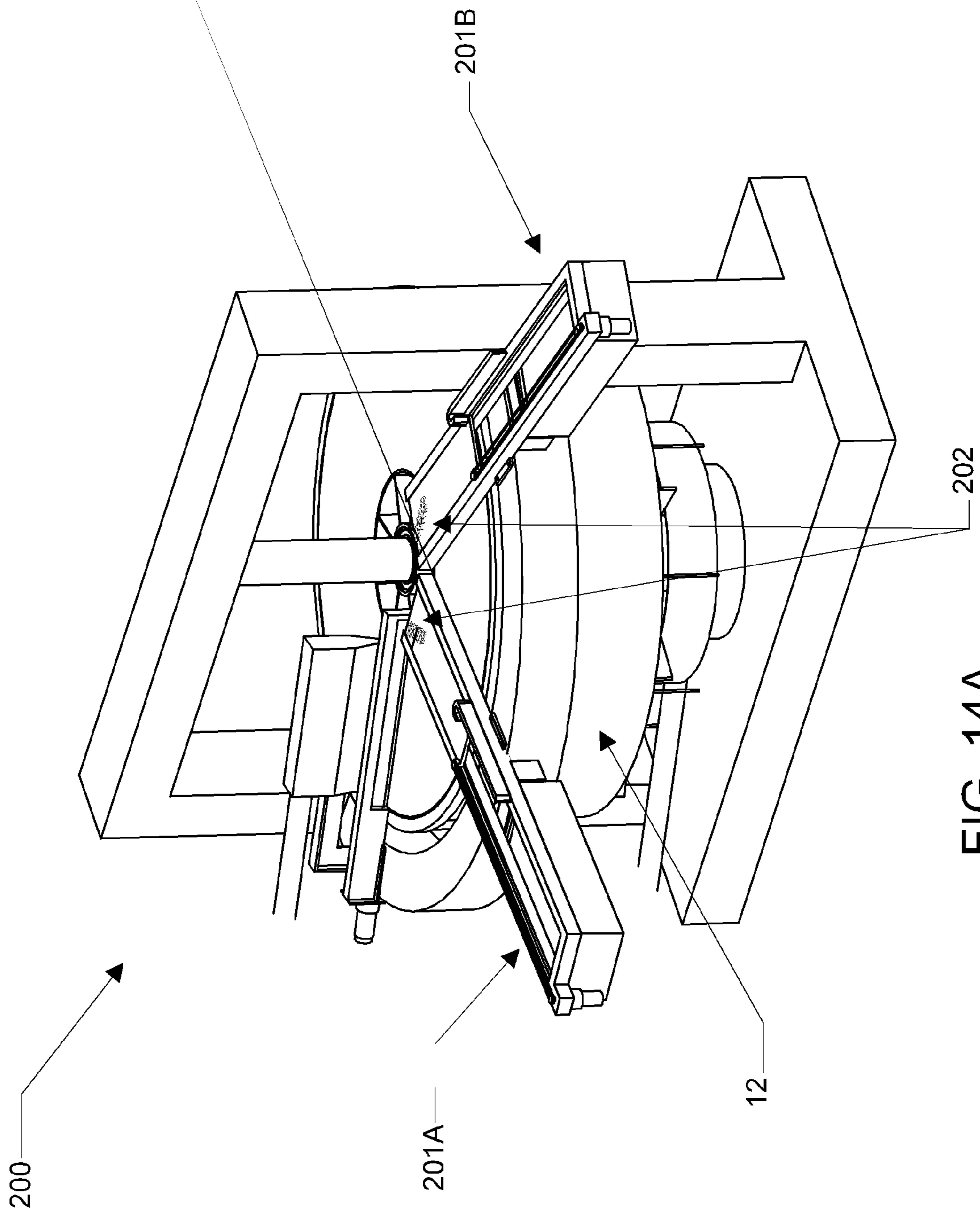

FIG. 14A

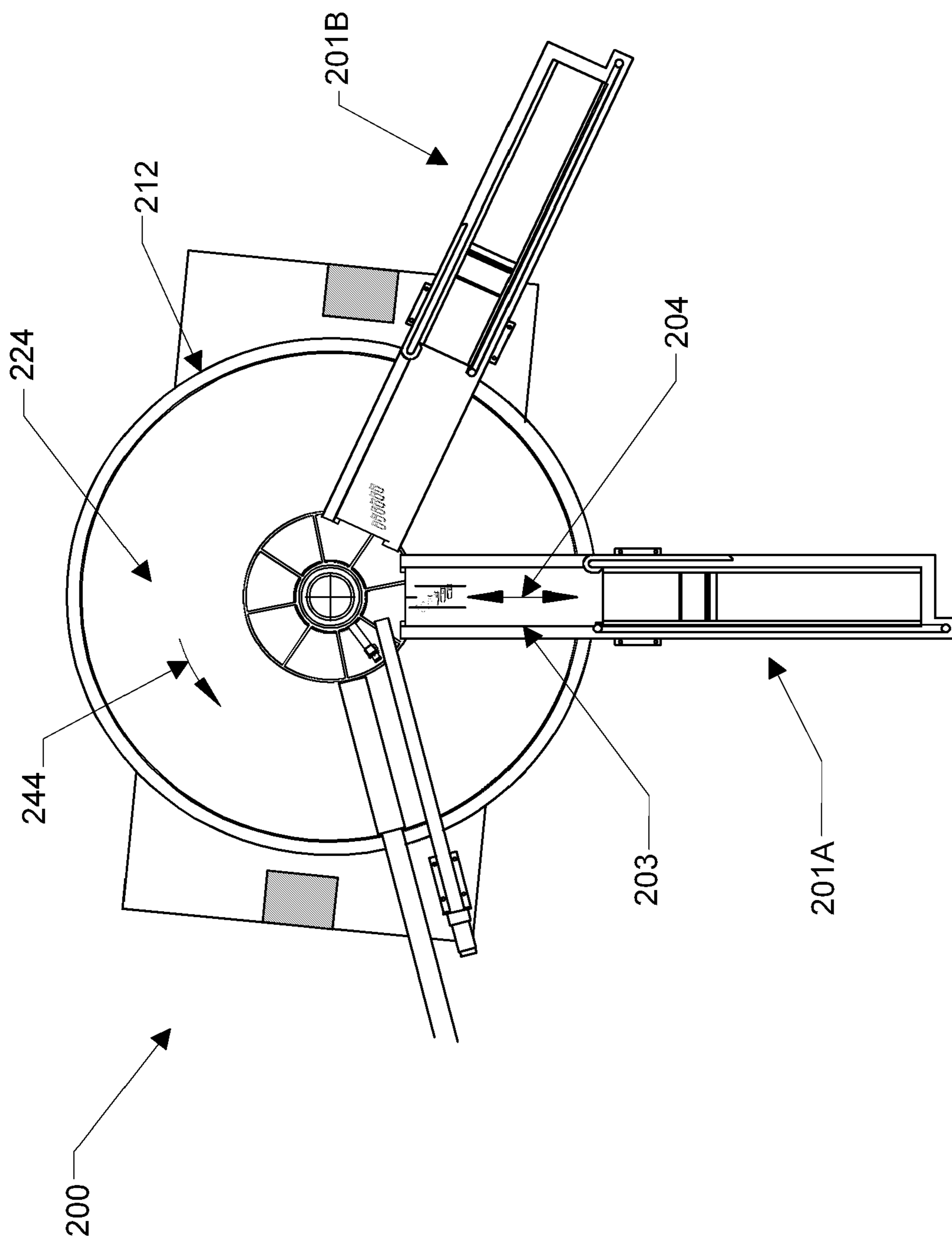

FIG. 14B

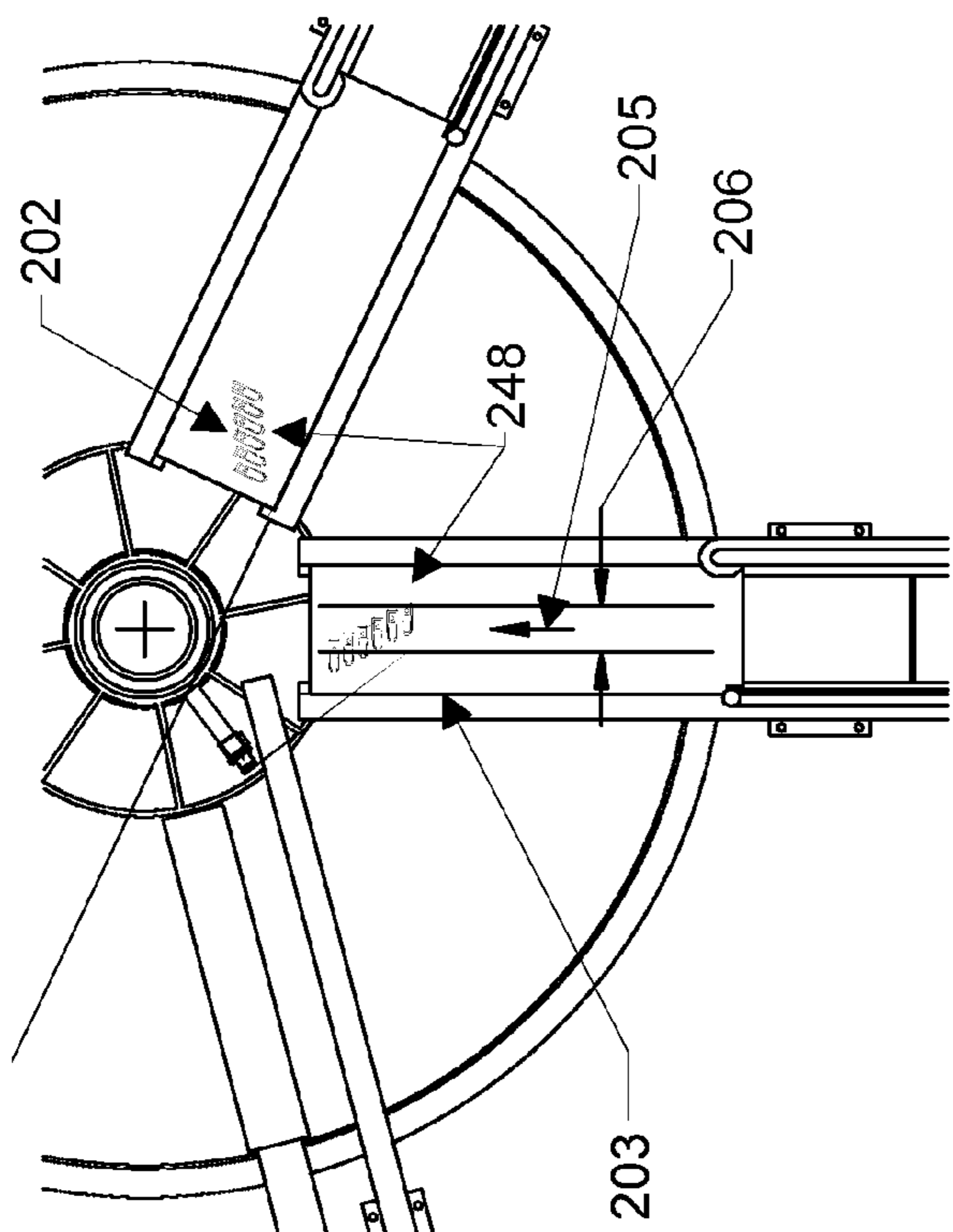

FIG. 14C

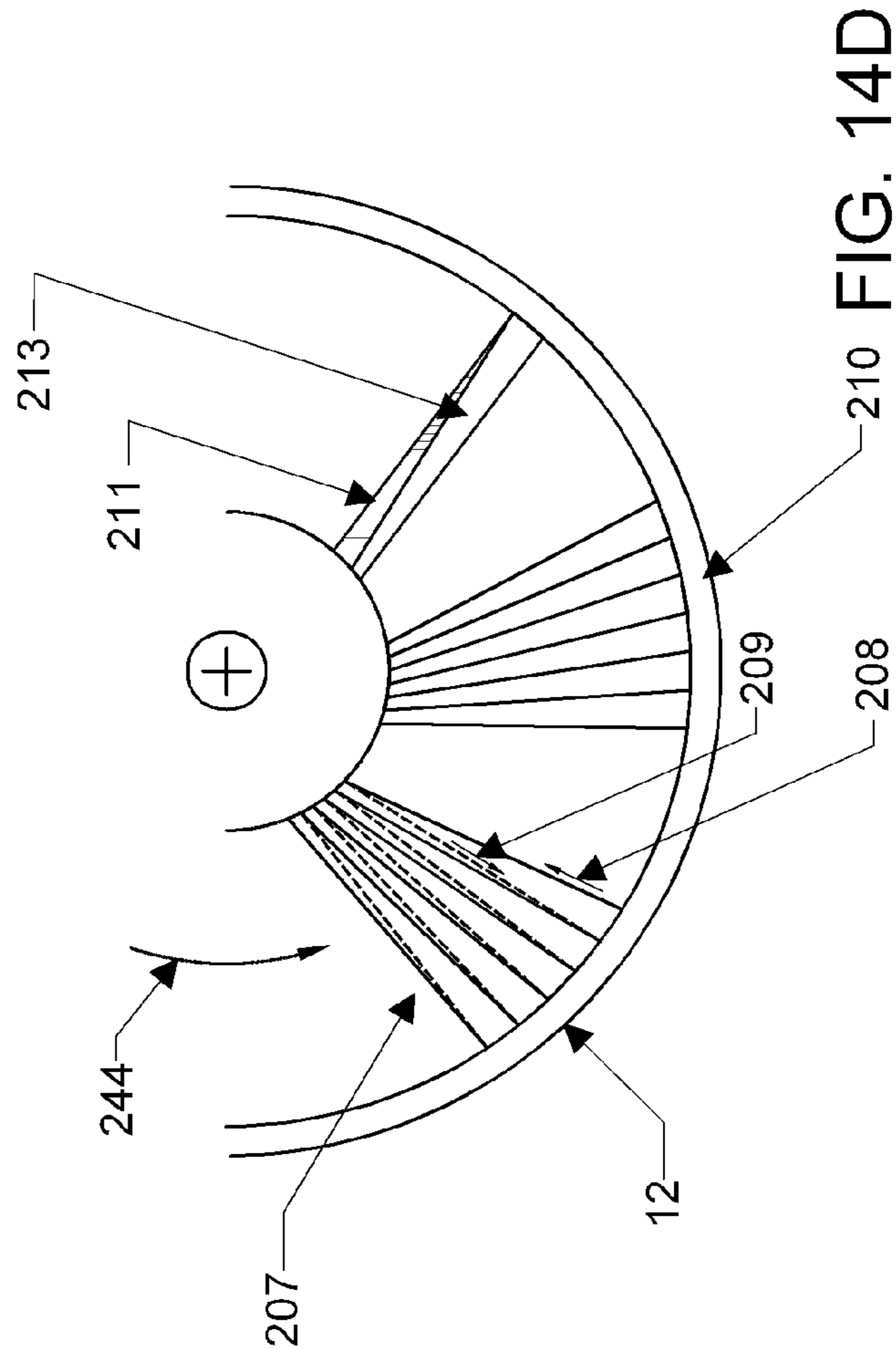

FIG. 14D

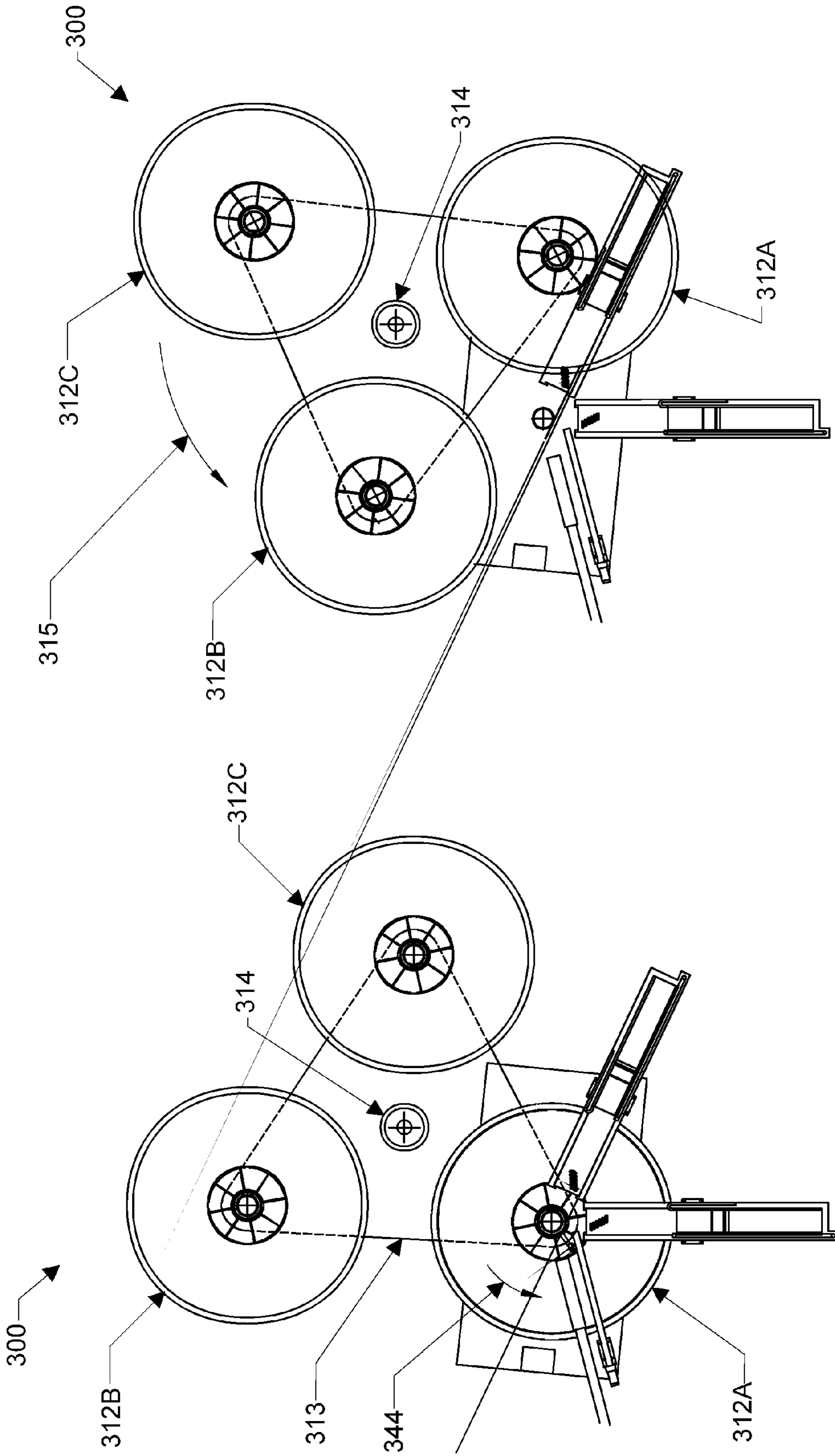

FIG. 15B

FIG. 15A

APPARATUS AND METHODS FOR 3D PRINTING**CROSS-REFERENCE TO RELATED APPLICATION**

[0001] This application incorporates by reference, and claims priority to and the benefit of, U.S. Provisional Patent Application Ser. No. 60/472,922, which was filed on May 23, 2003.

FIELD OF THE INVENTION

[0002] The present invention relates to apparatus and methods for creating three-dimensional objects by printing.

BACKGROUND

[0003] Generally, 3D printing involves the use of an inkjet type printhead to deliver a liquid or colloidal binder material to layers of a powdered build material. The printing technique involves applying a layer of a powdered build material to a surface typically using a roller. After the build material is applied to the surface, the printhead delivers the liquid binder to predetermined areas of the layer of material. The binder infiltrates the material and reacts with the powder, causing the layer to solidify in the printed areas by, for example, activating an adhesive in the powder. The binder also penetrates into the underlying layers, producing inter-layer bonding. After the first cross-sectional portion is formed, the previous steps are repeated, building successive cross-sectional portions until the final object is formed. See, for example, U.S. Pat. Nos. 6,375,874 and 6,416,850, the disclosures of which are incorporated herein by reference in their entireties.

[0004] Apparatus for carrying out 3D printing typically move the printheads over the print surface in raster fashion along orthogonal X and Y axes. In addition to the time spent printing, each printhead move requires time for acceleration, deceleration, and returning the printhead to the starting position of the next move. The inefficiencies inherent in these reciprocating motions reduce the productivity of the 3D printing process.

[0005] It is, therefore, an object of the present invention to provide apparatus and methods for continuously and efficiently performing 3D printing.

SUMMARY

[0006] Generally, the invention relates to apparatus and methods for producing three-dimensional objects, such as casting cores, toys, bottles, cans, architectural models, automotive parts, molecular models, models of body parts, cell phone housings, and footwear, more rapidly and efficiently than heretofore achievable. Additionally, the invention relates to systems and methods for maintaining and operating the aforementioned apparatus. In particular, if a user wants to produce large volumes of three-dimensional objects rapidly, a 3D printing apparatus in accordance with the invention can achieve a high throughput by continuously printing, using multiple printheads.

[0007] In one aspect, the invention relates to an apparatus for fabricating a three-dimensional object from a representation of the object stored in memory. The apparatus includes a rotary build table for receiving successive layers of a build material and an array having at least one printhead

disposed above the build table. In one embodiment, the rotary table rotates continuously.

[0008] In another aspect, the invention relates to an apparatus for fabricating a three-dimensional object from a representation of the object stored in memory. The apparatus includes a generally circular build table for receiving successive layers of a build material and an array having at least one printhead disposed above the build table and movable relative to the build table. In one embodiment, the generally circular build table is movable in a vertical direction. In various embodiments, the printhead is movable over at least a portion of a build surface defined by the generally circular build table and the printhead can move continuously about the build table. In one embodiment, the array is configured to dispense fluid at substantially any radial location of the build table by moving the array radially to the desired location.

[0009] In yet another aspect, the invention relates to a method of fabricating a three-dimensional object. The method includes the steps of depositing successive layers of a build material on a rotary build table and depositing a liquid in a predetermined pattern on each successive layer of the build material to form the three-dimensional object. In various embodiments, the method includes the steps of: rotating the build table continuously, distributing the build material over at least a portion of the build table with a spreader, measuring an amount of excess build material deposited on the build table, and adjusting the amount of build material deposited on the build table based on the amount of excess build material measured. Additionally, the liquid can be deposited by an array of one or more printheads.

[0010] In still another aspect, the invention relates to a method of fabricating a three-dimensional object. The method includes the steps of depositing successive layers of a build material on a generally circular build table and depositing a liquid in a predetermined pattern on each successive layer of the build material to form the three-dimensional object. In various embodiments, the liquid is deposited by an array of at least one printhead and the printhead is movable over at least a portion of a build surface defined by the generally circular build table. In addition, the printhead can move continuously about the build table and the build table can move in a vertical direction.

[0011] In various embodiments of the foregoing aspects, the apparatus includes a build material delivery system. The system includes a storage means for holding the build material and a conveying means for delivering the build material to the build table. In one embodiment, the storage means includes at least two storage chambers for holding at least two build material components separate from each other and the system further includes a blender for mixing the build material components in a predetermined ratio for delivery to the build table. In addition, the apparatus can include a spreader for distributing the build material over at least a portion of the build table. The spreader can be a counter-rotating roller, and the counter-rotating roller can be skewed with respect to a radius of the rotary build table to induce excess build material to migrate over an edge of the build table.

[0012] In additional embodiments, the apparatus can include a sensor disposed below an edge of the build table

to detect an amount of the excess build material. An amount of build material delivered to the build table can be adjusted in response to the amount of excess build material detected. In one embodiment, the sensor can automatically monitor printhead condition, and the apparatus can automatically modify its operation in response to a signal from the sensor. In one example, printhead cleaning is initiated if print quality is inadequate. In another example, the apparatus can utilize the redundant printheads in areas where the printing coverage is inadequate.

[0013] In other embodiments, the array can include a plurality of printheads disposed above the build table. In one embodiment, the array is configured to dispense fluid at substantially any radial location of the rotary build table without adjustment. In another embodiment, the array prints an entire surface of the build table by continuous consecutive radial scanning motions. In addition, the array can be adjusted incrementally radially and/or can be displaced from a normal printing position for servicing. Further, the array can be displaced radially with respect to the rotary build table. The array can include redundant printheads.

[0014] In further embodiments, the apparatus defines an opening for removing the three-dimensional object. In one embodiment, the three-dimensional object is removed through a top opening of the build table. Additionally, the apparatus can include a sensor to monitor at least one performance characteristic of the apparatus, such as print quality, printing errors, print speed, printhead condition, build material quantity, and table position. In one embodiment, the array is movable in response to a signal from the sensor. The apparatus can also include a plurality of rotary build tables.

[0015] In still other embodiments, the invention can include methods and apparatus for cleaning the printheads of the apparatus. Methods of cleaning the printhead can include wiping the printhead with a roller including a cleaning fluid, drawing a vibrating member across the printhead, drawing a cleaning fluid across the printhead by capillary action through a wick, and/or combinations thereof. In addition, the methods can include optionally the step of applying a vacuum to the printhead to remove debris. The apparatus for cleaning a printhead used in a 3D printer can include a wick disposed adjacent the printhead for drawing a cleaning fluid across the printhead.

[0016] In another aspect, the invention relates to an apparatus for cleaning a printhead used in a 3D printer. The pressure in the interior of a printhead is typically lower than atmospheric pressure. This negative pressure is balanced by the surface tension of the menisci that form over the outlets of the printhead nozzles. It is desirable to flush the accumulated powder off the face of the printhead with a clean wash solution without allowing the solution to be drawn into the printhead when the menisci are destroyed. This goal is achieved in this apparatus by maintaining an environment outside the printhead in which the pressure is lower than the pressure inside the head. In addition, this induced pressure differential causes binder to flow out of the heads through the nozzles, flushing out any powder that may have lodged in the nozzle passageways. The apparatus includes a base, a cam track disposed within the base, a cap carrier slidably engaged with the cam track, and a sealing cap defining a cavity and disposed on the carrier. The cap

being transportable into engagement with the face of the printhead by the carrier. In various embodiments the apparatus includes a cleaning fluid source in communication with the cap for cleaning the printhead face and a vacuum source in communication with the cap for removing used wash fluid and debris.

[0017] In further embodiments, the apparatus can also include a spring coupled to the carrier and the base to bias the carrier into a receiving position for receiving the printhead. In one embodiment, the carrier includes a stop disposed on a distal end of the carrier for engaging the printhead as the printhead enters the apparatus. The printhead slides the carrier rearward along the cam track after engaging the stop and until the printhead face and cap sealably engage. In a further embodiment, the apparatus includes a latch pawl coupled to the base for engaging with the carrier to prevent forward movement of the carrier and a squeegee disposed on a proximal end of the carrier. The squeegee is positioned to engage the printhead face as the printhead exits the apparatus.

[0018] In still another aspect, the invention relates to a method of cleaning a printhead used in a 3D printer. The method includes the step of receiving the printhead within an apparatus that includes a base, a cam track disposed within the base, a cap carrier slidably engaged with the cam track, and a sealing cap defining a cavity and disposed on the carrier. Additional steps include engaging the face of the printhead with the cap, drawing a vacuum on the cavity, and introducing a cleaning fluid into the cavity and into contact with the printhead face. In one embodiment, the method includes the step of removing the cleaning fluid from the cavity. The method can further include disengaging the cap from the printing surface and wiping the printing surface with a squeegee as the printhead is withdrawn from the apparatus.

[0019] In another aspect, the invention relates to an apparatus for cleaning or reconditioning a printhead. The apparatus includes a nozzle array for spraying a washing solution towards a face of a printhead and a wicking member disposed in proximity to the printhead face for removing excess washing solution from the printhead face.

[0020] In various embodiments, the nozzle array includes one or more individual nozzles. The wicking member and the printhead are capable of relative movement. A fluid source can also be included in the apparatus for providing washing solution to the nozzle array under pressure. In another embodiment, the wicking member includes at least one of a permeable material and an impermeable material.

[0021] The nozzle array can be positioned to spray the washing solution at an angle with respect to the printhead face. In another embodiment, the wicking member is disposed in close proximity to the printhead face, without contacting print nozzles located on the printhead face. The spacing between the wicking member and the print nozzles can be automatically maintained. In one embodiment, the spacing is maintained by causing a portion of the wicking member to bear on the printhead face in a location removed from the print nozzles. The apparatus can also include a basin for collecting washing solution and debris.

[0022] In another aspect, the invention relates to a method of cleaning or reconditioning a printhead. The method

includes the steps of positioning a face of the printhead relative to at least one nozzle and operating the at least one nozzle to spray washing solution towards the printhead face. Excess washing solution is then removed from the printhead face by passing a wicking member in close proximity to the printhead face, without contacting the printhead face.

[0023] In one embodiment, the step of operating the at least one nozzle includes spraying the washing solution at an angle to the printhead face. In another embodiment, the method can include the step of operating the printhead to expel washing solution ingested by the printhead during cleaning. The method can include automatically maintaining a space between the wicking member and print nozzles located on the printhead face by, for example, causing a portion of the wicking member to bear on the printhead face in a location removed from the print nozzles.

[0024] These and other objects, along with advantages and features of the present invention herein disclosed, will become apparent through reference to the following description, the accompanying drawings, and the claims. Furthermore, it is to be understood that the features of the various embodiments described herein are not mutually exclusive and can exist in various combinations and permutations.

BRIEF DESCRIPTION OF THE DRAWINGS

[0025] In the drawings, like reference characters generally refer to the same parts throughout the different views. In addition, the drawings are not necessarily to scale, emphasis instead generally being placed upon illustrating the principles of the invention. In the following description, various embodiments of the present invention are described with reference to the following drawings, in which:

[0026] FIG. 1 is a schematic top perspective view of one embodiment of an apparatus for 3D printing in accordance with the invention;

[0027] FIG. 2 is an enlarged schematic side perspective view of the apparatus of FIG. 1;

[0028] FIG. 3 is an enlarged schematic perspective view of a portion of the apparatus of FIG. 1;

[0029] FIG. 4 is a schematic top view of the apparatus of FIG. 1 illustrating the spreader apparatus;

[0030] FIG. 5A is a schematic partial cross-sectional view of the apparatus of FIG. 1 taken at line 5A-5A in FIG. 4;

[0031] FIG. 5B is an enlarged schematic perspective view of an overflow sensor in accordance with the invention;

[0032] FIG. 6A is a schematic perspective view of one embodiment of a system for 3D printing including a 3D printing apparatus and a build material delivery system in accordance with the invention;

[0033] FIG. 6B is a schematic perspective view of an alternative embodiment of a system for 3D printing including a 3D printing apparatus and a build material delivery system in accordance with the invention;

[0034] FIG. 7A is a schematic perspective view of one embodiment of an apparatus for 3D printing in accordance with the invention with a build drum partially cut-away;

[0035] FIG. 7B is a schematic perspective view of the apparatus of FIG. 7A with a portion of the build material removed from the build drum;

[0036] FIG. 8A is an enlarged schematic perspective of one embodiment of a printbar assembly including a print diagnostic station in accordance with the invention;

[0037] FIG. 8B is a schematic representation of the diagnostic station of FIG. 8A;

[0038] FIGS. 9A-9J are schematic representations of one embodiment of an apparatus and method for cleaning a printhead in accordance with the invention;

[0039] FIG. 10 is a schematic representation of one step of the method of cleaning a printhead depicted in FIGS. 9A-9J;

[0040] FIG. 11 is a schematic perspective view of an alternative embodiment of a printhead cleaning station in accordance with the invention;

[0041] FIGS. 12A-12C are schematic side and perspective views of a printhead being cleaned at the cleaning station of FIG. 11;

[0042] FIGS. 13A-13D are schematic perspective views of another alternative embodiment of a printhead cleaning station in accordance with the invention;

[0043] FIGS. 14A-14D are schematic representations of one embodiment of a radial printing process in accordance with the invention; and

[0044] FIGS. 15A and 15B are schematic top views of an alternative embodiment of an apparatus for 3D printing in accordance with the invention.

DETAILED DESCRIPTION

[0045] Embodiments of the present invention are described below. It is, however, expressly noted that the present invention is not limited to these embodiments, but rather the intention is that variations, modifications, and equivalents that are apparent to the person skilled in the art are also included.

[0046] FIGS. 1-3 depict an apparatus 10 for 3D printing. The apparatus 10 produces three-dimensional objects by depositing alternating layers of build material and binder on a build surface or in a container to print multiple layers that ultimately form the three-dimensional object. The apparatus 10 includes a rotary build table, in this case a build drum 12, a structural frame 14, a base 16, at least one printbar assembly 18, a powdered build material dispenser assembly 20, and a spreader assembly 22. In the embodiment shown, the apparatus 10 includes two printbar assemblies 18A, 18B. The apparatus 10 further includes a component-mounting surface 26 attached to the frame 14. In one embodiment, the component mounting surface 26 may be movable to provide access to the build drum 12. The various assemblies 18, 20, 22 are typically mounted to the component mounting surface 26 and/or the frame 14. It is generally advantageous, for maintenance purposes, for the assemblies 18, 20, 22 to be stationary and the build drum 12 to rotate. For example, with redundant stationary printbar assemblies 18, a user can change out one printbar assembly 18 while the other printbar assembly 18 continues to operate. In addition, the apparatus 10 can include essentially any number of printbar assemblies 18 mounted in a variety of configurations for accomplishing printhead redundancy, increasing print speeds, and/or printing multiple colors.

[0047] The build drum 12 shown is generally cylindrical in shape and is mounted about a center shaft 28 attached to the base 16 and the frame 14. A bottom surface 17 of the build drum 12 may be substantially perpendicular to a sidewall 19 of the build drum 12, or the bottom surface 17 can be angled. For example, the bottom surface 17 may be conical, such that the surface tilts toward a center point of the build drum 12. The tilt may be from about 1 degree to about 15 degrees or more. In such an arrangement, the dispenser, the spreader, and the printbars should be slanted to correspond to the angle of tilt.

[0048] In a particular embodiment, the build drum 12 is mounted on a rotary actuator 29 that rotates the build drum 12 about the center shaft 28. The rotary actuator 29 could be hydraulically, pneumatically, or electrically driven. The rotary actuator 29 can include gears and belts for driving the build drum 12. In addition, the rotary actuator 29 may include one or more encoders 46, or similar devices, that cooperate with a controller to monitor and adjust the speed and/or position of the build drum 12. The encoders 46 can also be used to control the firing of the printheads 48, such that the printheads 48 print accurately and repeatedly, regardless of variations in the rotational speed of the build drum 12.

[0049] The build drum 12 receives build material from the build material dispenser assembly 20 that is located adjacent to the build drum 12. In particular, the build material dispenser assembly 20 is mounted above the build drum 12 and dispenses build material onto the build drum 12 as it rotates. Typically, the build material dispenser assembly 20 deposits a predetermined amount of material onto the build drum 12 in the form of a line substantially along a radius of the build drum 12. Alternatively, the build material dispenser assembly 20 could include nozzles for spraying the material onto the build drum 12. In addition, the build material dispenser assembly 20 could include a volumetric adjuster, for manually or automatically adjusting the amount of material being deposited. The build material dispenser assembly 20 is supported on the component-mounting surface 26. In one embodiment, the build material dispenser assembly 20 may be supplied by a larger dispenser assembly located remotely from the apparatus 10 (see FIGS. 6A and 6B). Further, the build material dispenser assembly 20 may include an agitator to maintain the build material in a loose powder form.

[0050] Located adjacent the build material dispenser assembly 20 is the spreader assembly 22. The spreader assembly 22 spreads the build material uniformly across the build drum 12 as it rotates. The spreader assembly 22 is shown in greater detail in FIG. 3. The spreader assembly 22 includes a counter-rotating spreader roll 52 that spreads the build material radially across the build drum 12, thereby forming a build surface 24. The spreader assembly 22 also includes a roll scraper 54 that removes build material that may become stuck to the roll 52. The spreader assembly 22 is also mounted on the component-mounting surface 26.

[0051] The operation of the build drum 12 varies in different embodiments to accommodate the multiple layers of build material. For example, in one embodiment, the build drum 12 moves downwardly relative to the assemblies 18, 20, 22 mounted on the component mounting surface 26. In a particular embodiment, at least a portion of the center shaft

28 and the build drum 12 are threaded and the build drum 12 threadedly engages the center shaft 28. As the build drum 12 rotates, it moves down the center shaft 28. In another embodiment, as shown in FIGS. 2 and 5A, the build drum 12 includes a bottom surface 17 that moves downwardly relative to the build drum 12 to continuously receive layers of build material. The bottom surface 17 is moved vertically by one or more linear actuators 191. The linear actuators could be hydraulically, pneumatically, or electrically driven. In yet another embodiment, the assemblies 18, 20, 22 move upwardly relative to the build drum 12 and the build surface 24.

[0052] It is advantageous for a user to be able to remove finished parts without stopping the printing process, therefore, the build drum 12 may include structure for facilitating removal of completed parts. In one example, the build drum 12 includes an opening in its bottom or side surface that allows for removal of the parts from the bottom and/or side, while the apparatus 10 continues to print above. In this example, the apparatus 10 may print a bottom plate covering essentially the entire build surface 24 before printing any parts. The bottom plate(s) would separate the layers of printed parts to prevent the inadvertent removal of build material or unfinished parts. Alternatively, the user could stop the printing process and remove the parts manually from the top, bottom, or side (see FIGS. 7A and 7B).

[0053] As shown in FIG. 4, the spreader assembly 22 is disposed slightly non-radially, with respect to the build drum 12. The build material dispenser assembly 20 deposits a substantially radial line of material in front of the spreader assembly 22 as the build drum 12 rotates (arrow 44). The apparatus 10 can be configured to operate with the drum 12 rotating in a counter-clockwise direction when viewed from the top as illustrated or clockwise in a mirror image of the configuration shown. The non-radial spreader assembly 22 spreads the material, forcing the excess material to migrate towards a center opening 56 in the build drum 12. The excess material falls into an overflow tray 68 (see FIGS. 1-2) located beneath the build drum 12. In one embodiment, the apparatus 10 is configured to reclaim the excess material for later use. In the embodiment shown, the apparatus 10 includes an overflow sensor 58. The sensor 58 monitors the amount of excess material falling through the center opening 56. The sensor 58 sends a signal to the apparatus controller indicative of the amount of excess material measured. The apparatus 10 can, in response to the signal, adjust the amount of material dispensed by the build material dispenser assembly 20.

[0054] The sensor 58 is shown in greater detail in FIGS. 5A and 5B. FIG. 5A depicts the general location of the sensor 58 on the apparatus 10. The sensor 58 is disposed within the center opening 56 and is mounted to the non-rotating center shaft 28. FIG. 5B is an enlarged view of the sensor 58. The sensor 58 includes a shaft 66 for mounting the sensor 58 to the center shaft 28. At a distal end of the shaft 66 is a paddlewheel assembly including a magnetic sensor 60 and a series of magnets 62 located on individual legs 64 of the paddlewheel 65. As excess material falls, it impinges on the legs 64, causing the paddle wheel 65 to rotate. The speed and/or period of rotation can be used to ascertain the amount of excess material being deposited, which can be adjusted accordingly. Alternatively, other types of sensors or more than one sensor can be used.

[0055] Referring back to FIGS. 1-3, two printbar assemblies 18A, 18B are shown disposed about the apparatus 10. Each printbar assembly 18 includes a printhead carrier 42, for carrying at least one printhead 48, a service station 34, a printhead diagnostics station 38, a printbar motor 36, a printbar cable guide 32, and a printbar slide 30. One of the two assemblies 18A, 18B can be redundant to the other. Alternatively, many more printbar assemblies 18 could be included on the apparatus 10. The printbar cable guide 32 guides and secures the electrical connections to the printheads 48. The printbar slide 30 is attached to the component-mounting surface 26 and supports the printhead carrier 42, the service station 34, the printhead diagnostics station 38, and the printbar motor 36. The print bar motor 36 can be a servo type motor, used to radially move the printbar assembly 18 relative to the build drum 12 along the slide 30. It is generally advantageous to use a positioning system capable of accurate and repeatable control, because this directly influences the accuracy of the objects being produced. The printhead carrier 42 is radially movable to position the printheads 48 for printing and for performing service on the printheads 48.

[0056] The printhead carrier 42 can be moved along a radius of the build drum 12 to correct for deficiencies in print quality. For example, the printhead carrier 42 supports a printhead array 40, which may include any number of printheads 48, for example a single printhead 48 or eight rows of six printheads 48. The printhead array 40 may include redundant printheads 48, which compensate for the deficiencies in print quality. The printheads 48 can be commercially available inkjet type printheads or custom manufactured printheads to suit a particular application. The printheads 48 include multiple jets, for example 512 jets, each jet for depositing a drop of binder onto the build surface 24.

[0057] The printheads 48 can be moved incrementally back and forth along the radius in a "shingling" fashion to compensate for irregularities in printing, for example, if some jets are not working, misfire, or are out of alignment. Shingling allows the apparatus 10 to produce stronger parts, because printing errors are averaged out. For example, shingling reduces the affect of jets that are not printing properly by offsetting the jets by a small amount such that any line of unprinted build material caused by a missing jet is in a different location on each print layer. Shingling can be carried out in various ways, for example, in response to an error message or the apparatus 10 can be programmed to continuously shingle by moving the printheads 48 in and out along the radius a random distance between the printing of each layer. Alternatively, the apparatus 10 can be programmed to run a printing routine, where the printheads 48 are moved a set distance for a specific number of print layers and then reset to a starting position. For example, the printheads 48 can be moved out along the radius $\frac{1}{16}$ " for each print layer until the printheads 48 have been moved a total of $\frac{1}{4}$ ". Then, the printheads 48 can be moved back in along the radius to their starting position or be moved back incrementally. Therefore, the apparatus 10 is printing over the same areas with different printheads 48 to average out any errors.

[0058] FIGS. 14A-14D depict generally a radial scanning print process, where a printhead array moves continuously in and out along a radius of a build drum, as the build drum

rotates continuously. In such a process, the printhead array scans an entire build surface of the 3D printer. FIG. 14A is a schematic isometric view of a 3D printer 200 in accordance with the invention. The 3D printer 200 is similar to the 3D printer 10 previously described with respect to FIGS. 1-3. The 3D printer 200 includes a build drum 212 and two printbar assemblies 201A, 201B. Each printbar assembly 201A, 201B includes a printhead array 202. FIG. 14B is a schematic top view of the 3D printer 200 of FIG. 14A. The printbar assemblies 201A, 201B include printhead carriers 203 that move in and out, generally along a radius of the build drum 212, as shown by arrow 204. As shown in FIG. 14B, the build drum 212 includes a build surface 224 and rotates counter-clockwise, as shown by arrow 244. Generally, the build drum 212 moves relatively slowly, while the printhead carriers 203 move more rapidly.

[0059] FIGS. 14C and 14D are enlarged schematic top views of the 3D printer 200 of FIG. 14A. As shown in FIG. 14C, the printhead array 202 includes six printheads 248 staggered along a length of the printhead carrier 203; however, the array 202 could be made up of essentially any number or arrangement of printheads 248. The six staggered printheads 248 define the printing swath width 206. In one embodiment, each printhead 248 prints a $\frac{1}{2}$ " swath, resulting in a swath width 206 of about 3". The width 206 is obtained with all of the jets printing; however, different swath widths and shapes can be achieved by controlling the number and arrangement of jets that actually fire. As the printhead carrier 203 moves the printhead array 202 radially in and out, the printheads 248 print on the in stroke, as shown by arrow 205.

[0060] FIG. 14D depicts the specific details of the print swaths. Generally, the swaths print canted to a radius of the build drum 212, because the build drum 212 is rotating as the printheads 248 are printing along the radius. The printhead travel path 207 includes a print stroke 208 and a return stroke 209 (the lines shown represent the centerline of the printhead array 202). The return stroke 209 occurs as the printhead carrier 203 moves radially outward, and the print stroke 208 occurs as the printhead carrier 203 moves radially inward. When printing, not all of the jets are firing along the entire print stroke 208, resulting in a used printable area 213 and an unused printable area 211. This is done to compensate for the fact that the printed swaths would otherwise overlap as the build drum 212 rotates. As shown, the printed segments 210 abut one another, thereby forming a fully printed area, as shown. The used printable area 213 of the swath is widest at a point furthest from the center of the build drum 212.

[0061] It should be noted that the various 3D printers disclosed herein print based on polar coordinates (i.e., r, θ), as opposed to linear printers, which print based on rectangular coordinates (i.e., x, y). The disclosed 3D printers include logic for converting rectangular coordinates to polar coordinates for printing on a radial build surface. The converting logic typically resides in the controller that controls the operation of the 3D printer.

[0062] In addition, because the printheads are printing along a radius, not all of the jets of the printhead print every time. In particular, the jets located closest to the center of the print arrays tend to print less, thereby resulting in a longer duty life. Correspondingly, the printheads located on the outsides of the print arrays tend to fail first.

[0063] In one embodiment, the apparatus 10 can include one or more sensors to measure the print quality or other characteristics of the apparatus 10, such as print speed, printhead condition (e.g., an empty or dirty printhead), misfiring jets, build material quantity, and/or build drum position. In a particular embodiment, a sensor can monitor the print quality by determining if the printheads 48 are printing properly and, if not, can send a signal to the apparatus controller to shift the printheads 48 to compensate for printheads 48 that are not printing properly. For example, the controller could move the printheads 48 radially a very small amount for shingling purposes. In one embodiment, a sensor can be used to determine whether all, or at least a minimum number, of jets are firing and, if not, signal the user to replace a printhead 48. Additionally, sensors can be used to monitor and control other functions, such as running diagnostic tests, performing cleaning of the printheads 48, refilling the build material dispenser assembly 20, cleaning the spreader assembly 22, and performing any other desired function of the apparatus 10.

[0064] The printbar assembly 18 can also be moved for diagnostic or service purposes. Moving the printhead array 40 radially from the build drum 12 provides the user with access to the printheads 48 for maintenance purposes, such as cleaning or replacement. Printhead cleaning is described in detail with respect to FIGS. 9A-9J, 10, 11, 12A-12C, and 13A-13D. The printhead array 40 can also be moved radially outwardly to run a diagnostic routine of the printhead array 40 (see FIGS. 8A and 8B). In an alternative embodiment, the printbar assembly 18 can be raised from the build drum 12 for service purposes.

[0065] The size and exact configuration of the apparatus 10 can vary to suit a particular application. For example, the apparatus 10 could be sized to fit on a tabletop to produce relatively small three-dimensional objects, or the apparatus 10 could have a substantial footprint for producing relatively large three-dimensional objects. In a particular embodiment, the build drum 12 has an outside diameter of about six feet, an inside diameter of about two feet, and a depth of about two feet. The size of the build drum 12 can vary to suit a particular application. In addition, the apparatus 10 can be situated within an enclosure and can include air handling equipment for cleaning the work environment. The enclosure can include windows for monitoring operation of the apparatus 10.

[0066] Additionally, the apparatus 10 may include multiple build drums 12 and printbar assemblies 18. In one possible configuration, the apparatus 10 includes multiple build drums 12 spaced about a centrally located gantry that carries the printing components, i.e., material dispenser, spreader, and the printheads. The gantry can be rotated into position above one of the build drums 12. In this configuration, the user can be printing on one build drum 12 while removing parts from another build drum 12, thereby allowing for continuous operation. In another embodiment, the build drum 12 can be radially stationary, but vertically movable. In this embodiment, the printing components are configured to move radially about the build drum 12. In a particular embodiment, the gantry supporting the printing components rotates radially about the build drum 12 while the printheads move back and forth along a radius of the build drum 12. This configuration allows for printing over substantially the entire surface area of the build drum 12.

[0067] FIGS. 15A and 15B depict an alternative embodiment of a 3D printing apparatus 300 in accordance with the invention. As shown in FIG. 15A, the apparatus 300 includes three build drums 312 disposed on a carousel 313. The printing hardware is stationary as the carousel 313 rotates the build drums 312 around a carousel pivot shaft 314 into alignment with the printing hardware. The build drums 312 and printing hardware are essentially the same as previously described.

[0068] FIG. 15B depicts the carousel 313 rotating counter-clockwise (arrow 315) to move one build drum 312A out of alignment with the printing hardware and a second build drum 312B into alignment with the printing hardware. The carousel can rotate in either the clockwise or counter-clockwise direction. One advantage to this arrangement is that the apparatus 300 can be printing on one build drum 312C, while one set of printed objects can be curing in the second build drum 312B and another set of printed objects are being removed from the third build drum 312A.

[0069] FIGS. 6A and 6B depict systems 70, 92 for 3D printing utilizing two different build material feed systems 74, 96. Referring to FIG. 6A, the system 70 includes a 3D printing apparatus 72, similar to that previously described with respect to FIGS. 1-3, and the build material feed system 74 remotely connected to the 3D printing apparatus 72. The build material feed system 74 includes a storage bin, or hopper 80, for holding the build material and structure for conveying the build material to the 3D printing apparatus 72. The hopper 80 may include multiple internal compartments for holding multiple build material components that are mixed before being conveyed to the three-dimensional printing apparatus 72. Additionally, the multiple compartments might hold different types of build materials, with the build material feed system 74 including structure for delivering one or more different materials to the apparatus 72.

[0070] The build material feed system 74 shown in FIG. 6A includes a supply duct 82, a supply pump 84, a return (or overflow) duct 88, and a return (or overflow) pump 90. These components 82, 84, 88, 90 connect the hopper 80 with the 3D printing apparatus 72 and are capable of conveying a continuous or intermittent flow of material to the 3D printing apparatus 72, as needed. The ducts 82, 88 can be rigid or flexible or combinations thereof. For example, a flexible hose can be used at the connection points between the ducts 82, 88 and the 3D printing apparatus 72, while the portion of the ducts 82, 88 running between the build material feed system 74 and the 3D printing apparatus 72 can be rigid pipe. In alternative embodiments, the build material feed system 74 could include a conveyer belt system, a carousel, a feed screw, a gravity feed system, or other known components for transporting loose powder materials. The systems could be operated manually or driven pneumatically, hydraulically, or electrically. Additionally, the build material feed system 74 may include a main fill port or duct 86 on the hopper 80. Further, the build material feed system 74 may include one or more sensors connected to the controller 73 to monitor and control material levels in the hopper 80 and/or the amount and the rate of the materials being delivered to the 3D printing apparatus 72.

[0071] The hopper 80 is filled with build material, typically in powder form, via the duct 86. Alternatively, the hopper 80 may include a removable cover for filling. The

material is directly fed to the 3D printing apparatus 72 via the supply duct 82 exiting the bottom of the hopper 80. The supply pump 84 is located in the supply duct 82 to facilitate transportation of the material to a build material dispenser assembly 76 on the 3D printing apparatus 72. In the embodiment shown, the excess material is collected in a material overflow tray 78 located on the 3D printing apparatus 72 and returned directly to the hopper 80 via the return duct 88 and the return pump 90 located in the return duct 88. The material is returned to the top of the hopper 80. In an alternative embodiment, the return material is processed before being returned to the hopper 80. In a particular embodiment, the build material feed system 74 may include an agitation component to maintain the build material in a powder form. Alternatively or additionally, the build material feed system 74 may include components for handling build materials supplied in other than powder form.

[0072] As shown in FIG. 6B, the system 92 includes a 3D printing apparatus 94, similar to that previously described with respect to FIGS. 1-3, and the build material feed system 96 remotely connected to the 3D printing apparatus 94. The build material feed system 96 is similar to the system 74 described with respect to FIG. 6A and includes a hopper 102, a supply duct 106, a supply pump 108, a return (or overflow) duct 114, and a return (or overflow) pump 116. The build material feed system 96 further includes a blending assembly 110. In the embodiment shown, the blending assembly 110 is disposed in the supply duct feeding the 3D printing apparatus 94; however, the blending assembly 110 could be located in the hopper 102 to blend the materials before they leave the hopper 102.

[0073] The blending assembly 110 includes multiple component hoppers 112. In this configuration, the main hopper 102 holds one or more of the major constituents of the build material that are supplied to the blending assembly 110, such as sand. One or more additional constituents are introduced to the blending assembly 110 via the component hoppers 112. The blending assembly 110 controls the feed rate and blending of the various constituents to create the final build material. Additionally, the blending assembly 110 can blend the excess material received from the return duct 114 into the build material supplied to the 3D printing apparatus 94. In a particular embodiment, the blending assembly 110 meters the excess material into the blended build material in such a manner as to not effect the quality of the material being delivered to the 3D printing apparatus 94.

[0074] FIGS. 7A and 7B depict the removal of three-dimensional objects or printed parts 126 from one embodiment of a 3D printing apparatus 120 in accordance with the invention. In FIG. 7A, the build drum 124 is shown in partial section to illustrate the positioning of the printed parts 126. Layers of the build material accumulate in the build drum 124 and the printed parts 126 are surrounded by non-printed (unbound) build material 128. There are various ways of removing the parts 126; however, in the embodiment shown, the parts 126 are removed through a top opening 122 of the build drum 124. Specifically, the unbound build material 128 is evacuated from the build drum 124 by, for example, vacuuming. Alternatively, the unbound material 128 could be drained through bottom or side openings in the build drum 124. Once the unbound material 128 is removed, the parts 126 can be manually or automatically removed from

the build drum 124. In one embodiment, the top opening 122 is partially covered. The parts 126 may be further processed, as needed.

[0075] FIGS. 8A and 8B illustrate the diagnostic station 38 of FIG. 1. Other diagnostic systems are possible; for example detecting drops of binder or printing a test pattern on the build material. The diagnostic station 38, as shown in detail in FIG. 8B, includes chart paper 130 mounted between a paper supply roll 132 and a paper take-up roll 134, an optical scanner 138, a fixed reference printhead 140, and a paper drive capstan 136. The capstan 136 is used to accurately feed and position the chart paper 130. To run a diagnostic test, a portion of the printhead array 40 is moved in position over the diagnostic station 38 (arrow 142 in FIG. 8A). A clean section of chart paper 130 is positioned below the printhead array 40 (arrow 144 in FIG. 8A). The printheads 48, including the reference printhead 140, print on the chart paper 130. The printed test pattern is passed under the optical scanner 138 for analysis. In one embodiment, the optical scanner 138 is a CCD camera that reads the test image. The apparatus controller 73, via the diagnostic station 38, is able to determine if the printheads 48 are printing correctly or are in need of cleaning or replacement. In an alternative embodiment, the chart paper 130 may move continuously while the printhead array 40 moves continuously over it, printing a test pattern on the paper.

[0076] FIGS. 9A-9J illustrate a system 146 for cleaning a printhead 150. The system 146 is located in the service station 34 (FIG. 1). In one embodiment, the system 146 includes a cleaning station 148 made up generally of a latch pawl 152, a spring 154, a squeegee 156, a printhead cap 158, a cap carrier 192, a second spring 162, and a cam track 164. Only a single cleaning station 148 is shown for descriptive purposes; however, multiple stations 148 may be disposed in the service station 34. Alternatively, a single cleaning station 148 may service multiple printheads 150 by, for example, successively positioning the printheads 150 relative to the cleaning station 148.

[0077] FIG. 9A represents a starting position of the cleaning system 146. As shown in FIG. 9B, the printhead 150 approaches the cleaning station 148 and engages the latch pawl 152. The latch pawl 152 is actuated as the printhead 150 passes over the latch pawl 152. The printhead 150 continues to move past the latch pawl 152 and engages the squeegee 156 (FIG. 9C). The printhead 150 passes over squeegee 156. As shown in FIG. 9D, the printhead 150 contacts the cap carrier 192, which is driven along the cam track 164 and compresses the spring 162. The printhead cap 158 is positioned against a printhead face 160 (FIGS. 9E and 9F). As shown in FIG. 9F, the printhead cap 158 seals against the printhead face 160 while the face 160 is rinsed with wash fluid (see FIG. 10).

[0078] After the printhead face 160 is cleaned, the printhead 150 begins to move out of the cleaning station 148 (FIG. 9G). The latch pawl 152 engages the cap carrier 192, halting its movement. As shown in FIG. 9H, the printhead 150 engages the squeegee 156, which wipes the printhead face 160. In an alternative embodiment, the squeegee 156 vibrates to further clean the printhead face 160. The printhead 150 continues its forward movement, actuating the latch pawl 152 (FIG. 9I), which, in turn, releases the cap

carrier **192** (FIG. 9J). The cap carrier **192** snaps back to the start position. The system **146** is now ready to clean another printhead **150**.

[0079] FIG. 10 depicts the action of FIG. 9F in greater detail. The printhead **150** is positioned with the printhead face **160** against the printhead cap **158**, which in this embodiment is made of rubber. The cap includes a seal lip **172** for sealing about the printhead face **160**. The cleaning station **148** is coupled to a wash fluid supply container **182** via a supply duct **184** and a wash fluid return container **186** via a return duct **188**. The wash fluid return container **186** is in communication with a vacuum source **180**, in this case a vacuum pump, via a vacuum duct **190**. Additionally, a valve **178** is located in the return duct **188**. The valve **178** may be manually or automatically actuated.

[0080] In operation, the vacuum source **180** creates a vacuum within a cavity **174** in the printhead cap **160**. The vacuum pulls wash fluid from the supply container **182** through the supply duct **184**. The wash fluid enters the cavity **174** as a spray **176** against the printhead face **160**. The spray **176** washes debris, such as excess build material and dried binder, off the printhead face **160**. The used wash fluid and debris are drawn out of the cavity **174** by the vacuum source **180** and into the return container **186** via the return duct **188**. Additionally, the negative pressure created in the cavity **174** by the vacuum source **180** prevents the wash fluid from entering the jet nozzles and, in fact, may cause a small amount of binder to flow out of the nozzles to flush any powdered build material out of the nozzle. Blockages or obstructions in the jet nozzles can cause the jets to fire in the wrong direction. Once the operation is complete, the system **148** moves onto the step depicted in FIG. 9G.

[0081] FIG. 11 depicts an alternative embodiment of a cleaning station, also referred to as a reconditioning station **406**. The reconditioning station **406** is shown removed from the printing apparatus **10**; however, the reconditioning station **406** can be included on the printbar assembly **18** or in the service station **34**. The reconditioning station **406** includes a plurality of wiping elements **408** and a plurality of lubricators **410**. The wiping elements **408** and the lubricators **410** are mounted on a plate **412** that can be actuated to travel, as indicated by arrow **401**. The engaging surfaces **414** of the wiping elements **408** and the lubricators **410** are disposed upwards so that when the printhead **476** is in the reconditioning station **406**, the wiping elements **408** and the lubricators **410** clean the printheads **476** from below (FIGS. 12A-12C). Also, in the illustrated embodiment, one wiper **408** and one lubricator **410** acting as a pair **416** are used to clean each printhead **476**. Further, in the illustrated embodiment, each wiper and lubricator pair **416** are offset from each other to correspond with the offset spacing of the printheads **476** (see, for example, printheads **48** in FIG. 8A). In other embodiments, however, any number of wiping elements **408** and lubricators **410** can be used to clean the printheads **476**, and the wiping elements **408** and lubricators **410** can be spaced using any desirable geometry.

[0082] FIGS. 12A-12C depict one method of using the reconditioning station **106**. The printhead(s) **476** is disposed above the reconditioning station **406** (FIG. 12A). The plate **412** on which the wiping elements **408** and lubricators **410** are mounted is then actuated into alignment with the printheads **476**, and the printheads **476** are wiped and lubricated

from beneath to remove any accumulated grit and to improve the flow of binding material out of the printheads **476**. Specifically, the lubricator **410** applies a lubricant to the printhead face **477** to moisten any debris on the printhead face **477**. Then, the printhead **476** is moved to pass the printhead face **477** over the wiping element **408** (e.g., a squeegee), which wipes the printhead face **477** clean. Alternatively, the printhead face **477** could be exposed to a vacuum source to remove any debris present thereon.

[0083] FIGS. 13A-13D depict an alternative embodiment of a reconditioning station **506** in accordance with the invention. The reconditioning station **506** may also be mounted in the service station **34**. The reconditioning station **506** includes a reservoir **542** that holds a washing solution **543** and a pump **545** that delivers the washing solution **543** under pressure to at least one nozzle **540** and preferably an array of nozzles **540**. The nozzles **540** are capable of producing a high velocity stream of washing solution **543**. In operation, the nozzles **540** are directed to the printhead face **577** of the printhead **576**. When directed onto the printhead face **577**, the washing solution **543** loosens and removes contaminants, such as build material and binding material, from the printhead face **577**. The orientation of the nozzles **540** may be angled with respect to the printhead face **577**, such that a fluid flow is induced across a plane of the printhead face **577**. For example, the washing solution can contact the printhead **576** at the side nearest the nozzles **540** and drain from the side of the printhead **576** furthest from the nozzles **540**. This approach improves the efficacy of the stream of washing solution **543** by reducing the accumulation of washing solution on the printhead face **577**, as well as the amount of washing solution **543** and debris that would otherwise drain near and interfere with the nozzles **540**. A splash guard may also be included in the reconditioning station **506** to contain splashing resulting from the streams of liquid washing solution **543**.

[0084] It is desirable to remove a large portion of the washing solution **543** that remains on the printhead face **577** after the operation of the nozzles **540** is complete. This is conventionally accomplished by drawing a wiping element **408** across the printhead face **477**, as shown in FIG. 12C. A disadvantage of this approach is that contact between the wiping element **408** and the printhead face **477** may degrade the performance of the printhead **476** by, for example, damaging the edges of the inkjet nozzle orifices. Accordingly, it is an object of this invention to provide a means of removing accumulated washing solution from the printhead face **577**, without contacting the delicate region around the inkjet nozzles. In one embodiment, a wicking member **544** may be disposed such that the printhead face **577** may pass one or more times over its upper surface **546** in close proximity, without contact, allowing capillary forces to draw accumulated washing solution **543** away from the printhead face **577**. The wicking member **544** may be made from rigid, semi-rigid, or compliant materials, and can be of an absorbent or impermeable nature, or any combination thereof.

[0085] For the wicking member **544** to effectively remove accumulated washing solution **543** from the printhead face **577**, the gap between the upper surface **546** of the wicking member **544** and the printhead face **577** must be small, a desirable range being between about 0 inches to about 0.03 inches. A further object of this invention is to provide a

means for maintaining the gap in this range without resort to precise, rigid, and costly components.

[0086] In another embodiment, the wicking member 544 may consist of a compliant rubber sheet oriented approximately orthogonal to the direction of relative motion 547 between the wicking member 544, and the printhead 576 and with a portion of its upper edge 546 disposed so that it lightly contacts or interferes with the printhead face 577 only in non-critical areas away from the printhead nozzle orifices. The upper edge 546 of the wicking member 544 may include one or more notches 548 at locations where the wicking member 544 might otherwise contact delicate components of the printhead face 577. System dimensions are selected so that the wicking member 544 always contacts the printhead face 577, and is deflected as the printhead 576 passes over it, independent of expected variations in the relative positions of the printhead 576 and the reconditioning station 506. The upper edge 546 accordingly follows the position of the printhead face 577, maintaining by extension a substantially constant space between the printhead face 577 and the relieved surface notch 548. To further prolong the life of the printhead 576, a bending zone of the wicking object 544 can be of reduced cross-section to provide reliable bending behavior with little deformation of the upper edge 546 of the wicking member 544.

[0087] FIGS. 13B-13D illustrate a reconditioning cycle in accordance with the invention. FIG. 13B shows the printhead 576 approaching the reconditioning station 506 along the path 547. When the printhead 576 lightly contacts the wiping member 544, as shown in FIG. 13C, motion stops along the path 547 and the washing solution 534 is directed at the printhead face 577 by the nozzle array 540. When the spraying operation is complete, the printhead 576 continues to travel along the path 547, as shown in FIG. 13D. The wiping member 544 is further deflected to allow passage of the printhead 576, and the accumulated washing solution 543 is wicked away from the printhead face 577. After being sprayed and wiped, the printhead 576 may print a plurality of droplets to eject any washing solution that may have been ingested during the reconditioning process.

[0088] Additional cleaning methods are contemplated, such as wiping the printhead face with a cylindrical "paint roller" that cleans and moistens itself by rolling in a reservoir of wash fluid. In another embodiment, a cleaning system could include a continuous filament that carries wash fluid up to a printhead face and carries debris away to a sump. The system may include a small scraper that can be run over the filament to remove built up debris.

[0089] Having described certain embodiments of the invention, it will be apparent to those of ordinary skill in the art that other embodiments incorporating the concepts disclosed herein may be used without departing from the spirit and scope of the invention. The described embodiments are to be considered in all respects as only illustrative and not restrictive.

What is claimed is:

1-26. (canceled)

27. A method of fabricating a three-dimensional object comprising the steps of:

depositing successive layers of a build material on a rotary build table; and

depositing a liquid in a predetermined pattern on each successive layer of the build material to form the three-dimensional object.

28. The method of claim 27 further comprising the step of rotating the build table continuously.

29. The method of claim 27, wherein the step of depositing successive layers of a build material on a rotary build table includes distributing the build material over at least a portion of the build table with a spreader.

30. The method of claim 27 further comprising the step of measuring an amount of excess build material deposited on the rotary build table.

31. The method of claim 30 further comprising the step of adjusting the amount of build material deposited on the rotary build table based on the amount of excess build material measured.

32. The method of claim 27, wherein the step of depositing a liquid is performed by an array of at least one printhead.

33. The method of claim 32, wherein the array is configured to dispense fluid at substantially any radial location of the rotary build table without adjustment.

34. The method of claim 32, wherein the array prints an entire surface of the build table by continuous consecutive radial scanning motions.

35. The method of claim 32, wherein the array of print-heads can be adjusted incrementally radially relative to the rotary build table.

36-42. (canceled)

43. An apparatus for cleaning a printhead used in a three-dimensional printer, the apparatus comprising:

a base;

a cam track disposed within the base;

a cap carrier slidably engaged with the cam track; and

a sealing cap defining a cavity and disposed on the carrier, the cap being transportable into engagement with a face of the printhead by the carrier.

44. The apparatus of claim 43 further comprising:

a cleaning fluid source in communication with the cap for cleaning the printhead face; and

a vacuum source in communication with the cap for removing used wash fluid and debris.

45. The apparatus of claim 44, wherein the vacuum source creates a negative pressure within the cavity, the negative pressure preventing the wash fluid from entering a jet nozzle and drawing at least one of a binder fluid and debris from the jet nozzle.

46. The apparatus of claim 43 further comprising a spring coupled to the carrier and the base to bias the carrier into a receiving position for receiving the printhead.

47. The apparatus of claim 46, wherein the carrier includes a stop disposed on a distal end of the carrier for engaging the printhead as the printhead enters the apparatus and the printhead slides the carrier rearward along the cam track after engaging the stop until the printhead face and cap sealably engage.

48. The apparatus of claim 47 further comprising a latch pawl coupled to the base for engaging with the carrier to prevent forward movement of the carrier.

49. The apparatus of claim 48 further comprising a squeegee disposed on a proximal end of the carrier, the squeegee positioned to engage the printhead face as the printhead exits the apparatus.

50. A method of cleaning a printhead used in a three-dimensional printer comprising the steps of:

receiving the printhead within an apparatus comprising:

a base;

a cam track disposed within the base;

a cap carrier slidably engaged with the cam track; and

a sealing cap defining a cavity and disposed on the carrier;

engaging a face of the printhead with the cap;

drawing a vacuum on the cavity; and

introducing a cleaning fluid into the cavity and into contact with the printhead face.

51. The method of claim 50 further comprising the step of removing the cleaning fluid from the cavity.

52. The method of claim 51 further comprising the steps of:

disengaging the cap from the printhead face; and

wiping the printhead face with a squeegee as the printhead is withdrawn from the apparatus.

53. The method of claim 50, wherein the vacuum source creates a negative pressure within the cavity, the negative pressure preventing the wash fluid from entering a jet nozzle and drawing at least one of a binder fluid and debris from the jet nozzle.

* * * * *