

US 20070294955A1

(19) **United States**

(12) **Patent Application Publication**
Sportel

(10) **Pub. No.: US 2007/0294955 A1**

(43) **Pub. Date: Dec. 27, 2007**

(54) **TOWER FOR A WIND TURBINE,
PREFABRICATED METAL WALL PART FOR
USE IN A TOWER FOR A WIND TURBINE
AND METHOD FOR CONSTRUCTING A
TOWER FOR A WIND TURBINE**

(30) **Foreign Application Priority Data**

Apr. 2, 2004 (EP) 04075337.8

Publication Classification

(51) **Int. Cl.**
E04H 12/08 (2006.01)

(52) **U.S. Cl.** **52/40**

(75) Inventor: **Heiko Sportel**, CE Uitgeest (NL)

Correspondence Address:
STEVENS DAVIS MILLER & MOSHER, LLP
1615 L STREET, NW
SUITE 850
WASHINGTON, DC 20036 (US)

(57) **ABSTRACT**

A tower for a wind turbine. The tower has an exterior side and an interior side. The tower is at least partly composed of prefabricated metal wall parts. Each wall part includes an essentially quadrangular portion having an outwardly facing surface in the direction of the exterior of the tower and an inwardly facing surface in the direction of the interior of the tower. The portion having a top edge, a bottom edge, a first side edge and a second side edge. The first side edge is provided with a first flange along at least part of the length of the first side edge and the second side edge is provided with a second flange along at least part of the length of the second side edge. A method for constructing a tower for a wind turbine.

(73) Assignee: **Corus Staal BV**, Ijmuiden (NL)

(21) Appl. No.: **10/587,301**

(22) PCT Filed: **Jan. 14, 2005**

(86) PCT No.: **PCT/EP05/00550**

§ 371(c)(1),
(2), (4) Date: **Jun. 29, 2007**

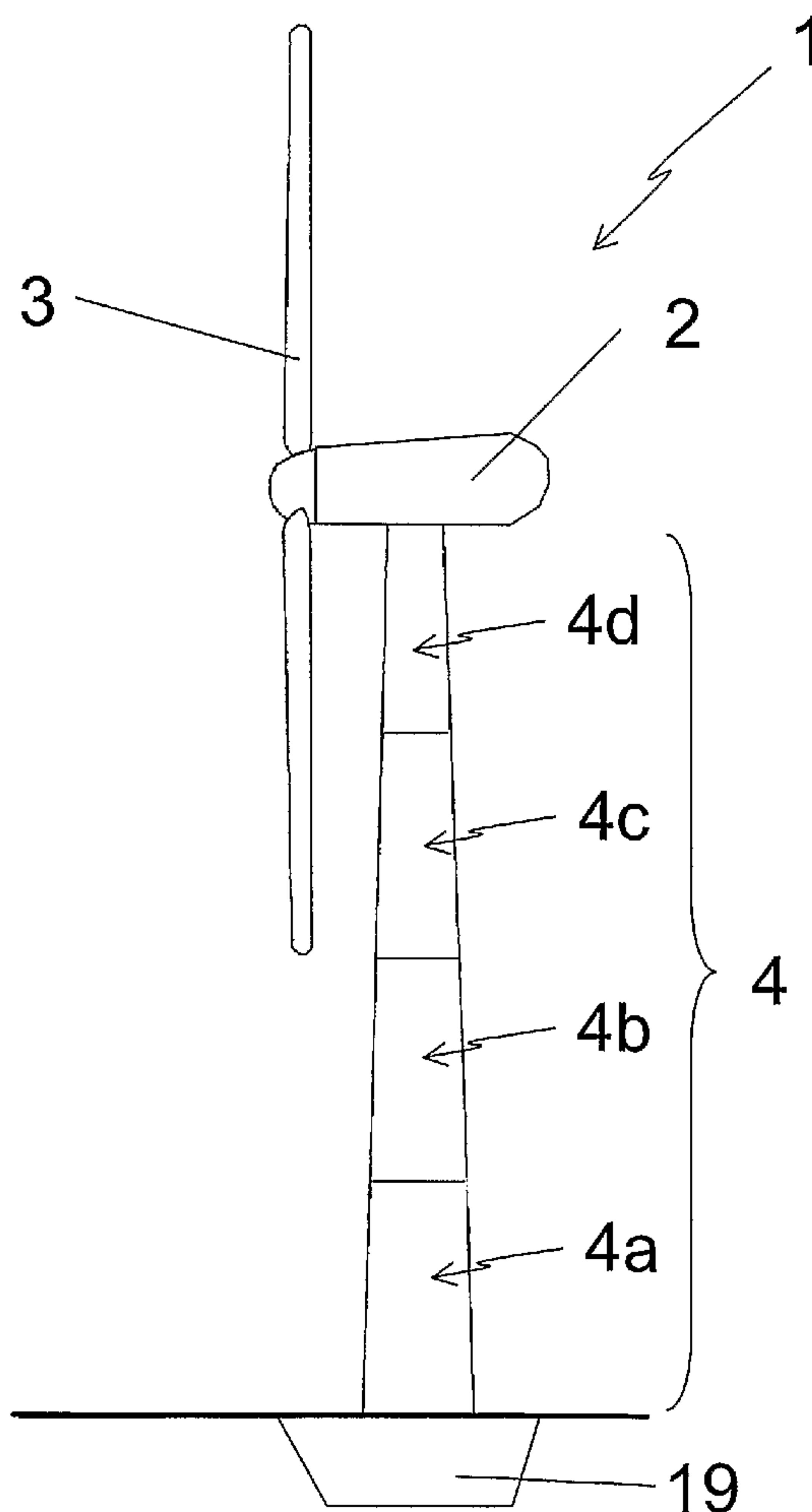

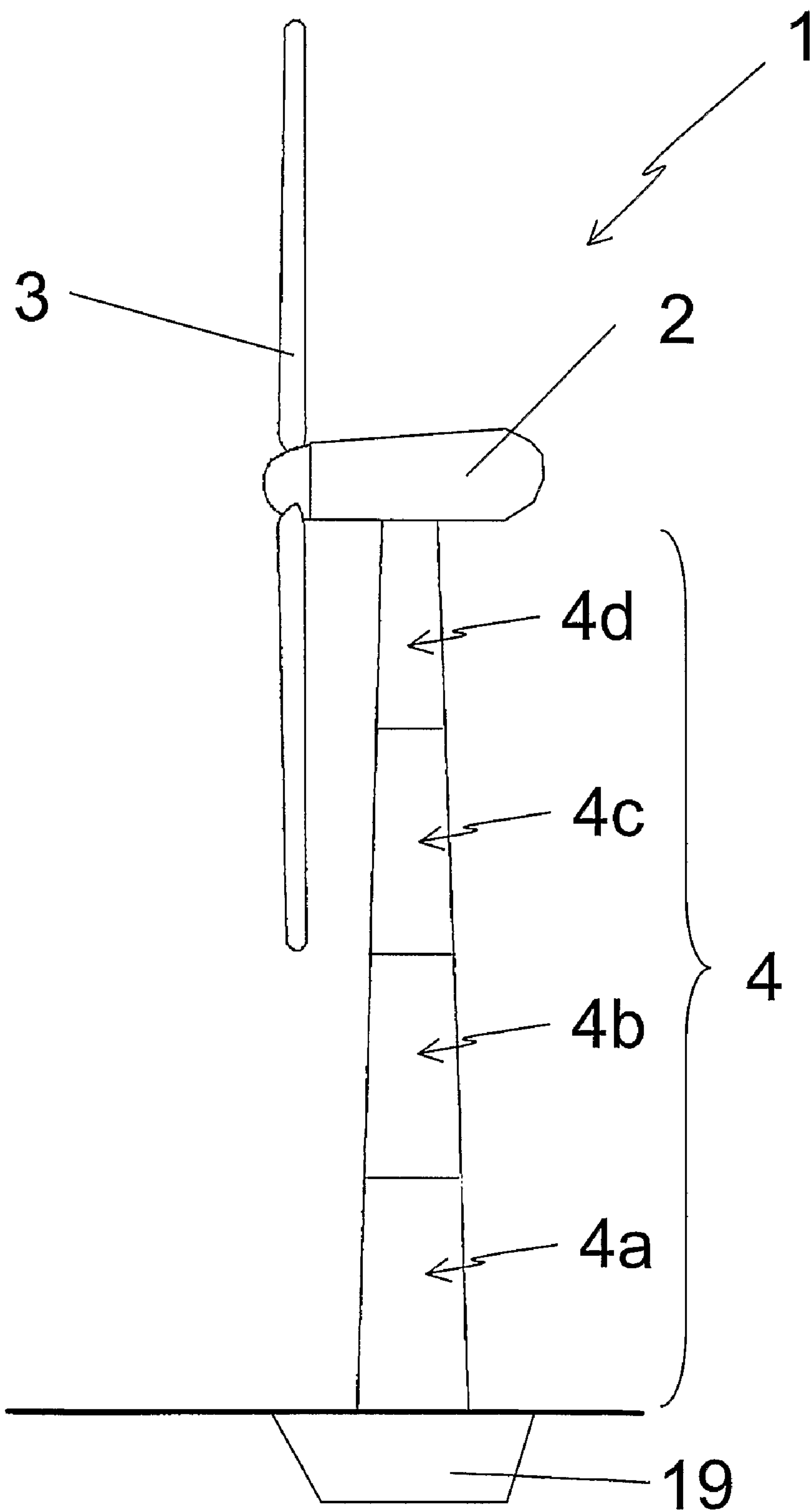

Fig. 1

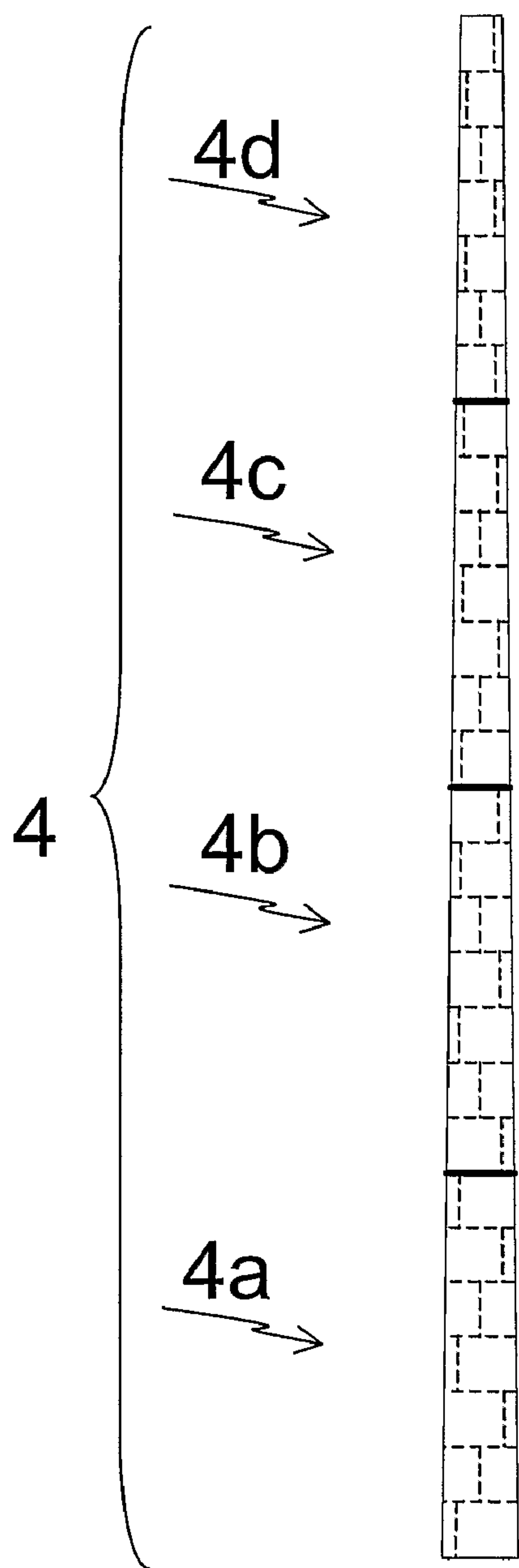

Fig. 2

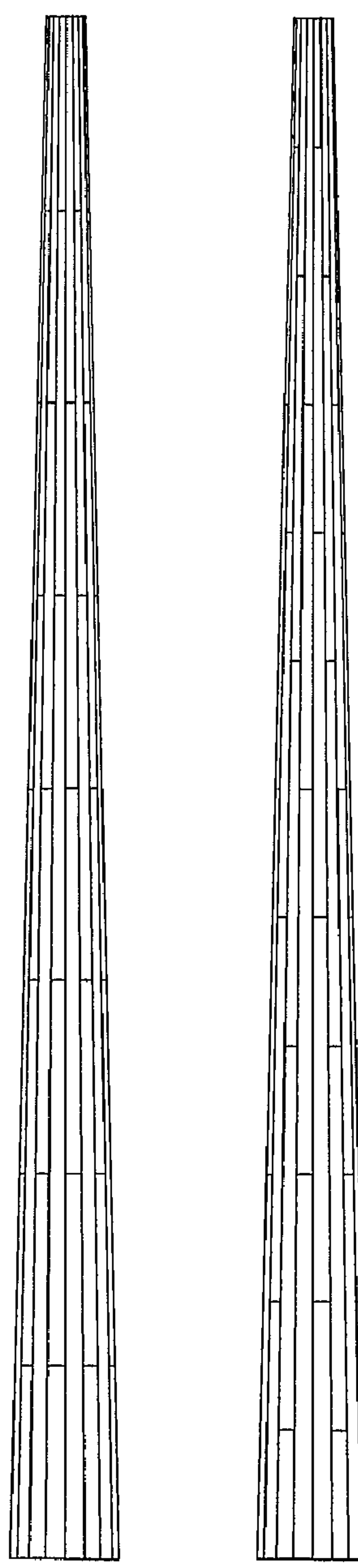

Fig. 3

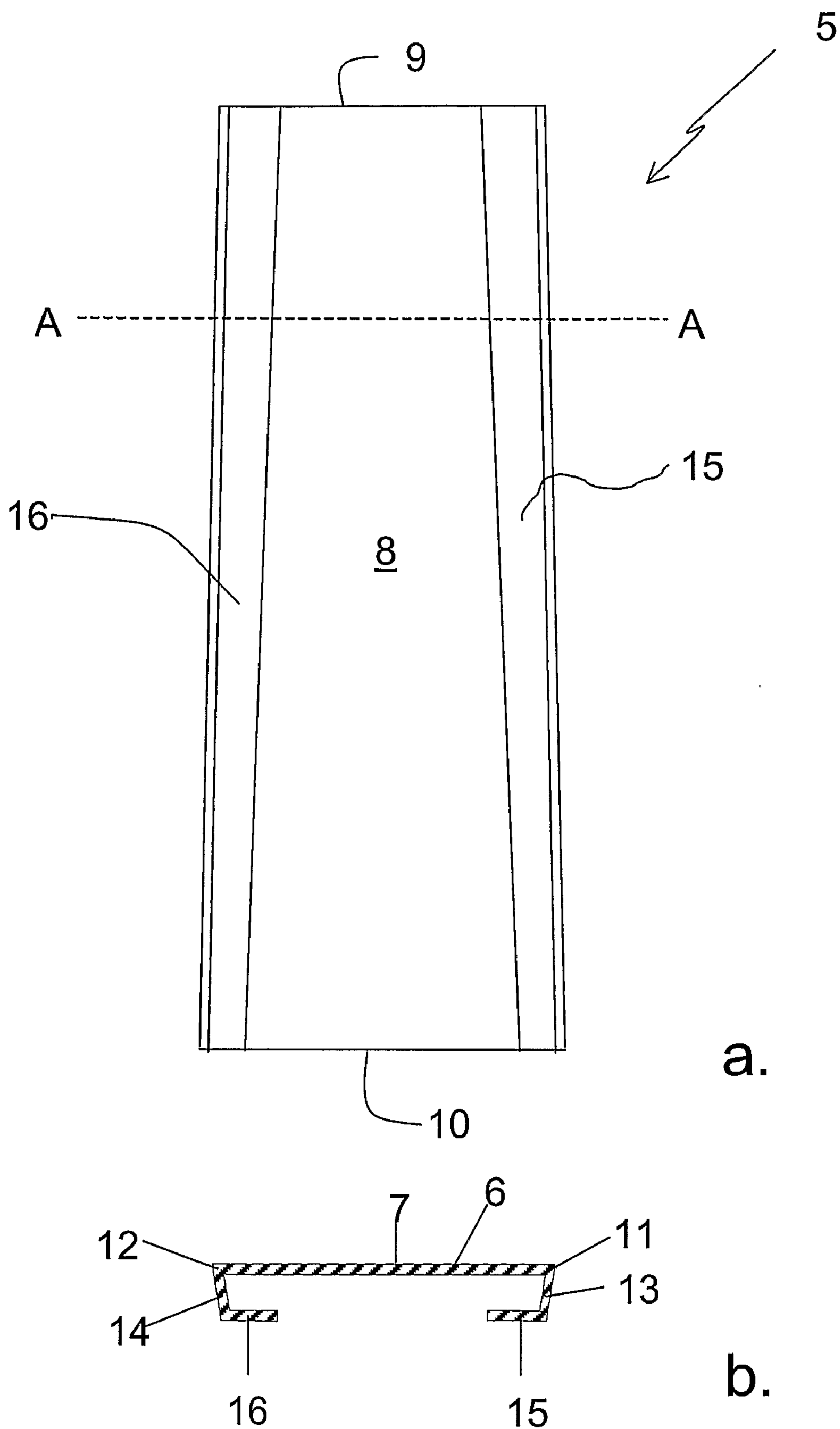
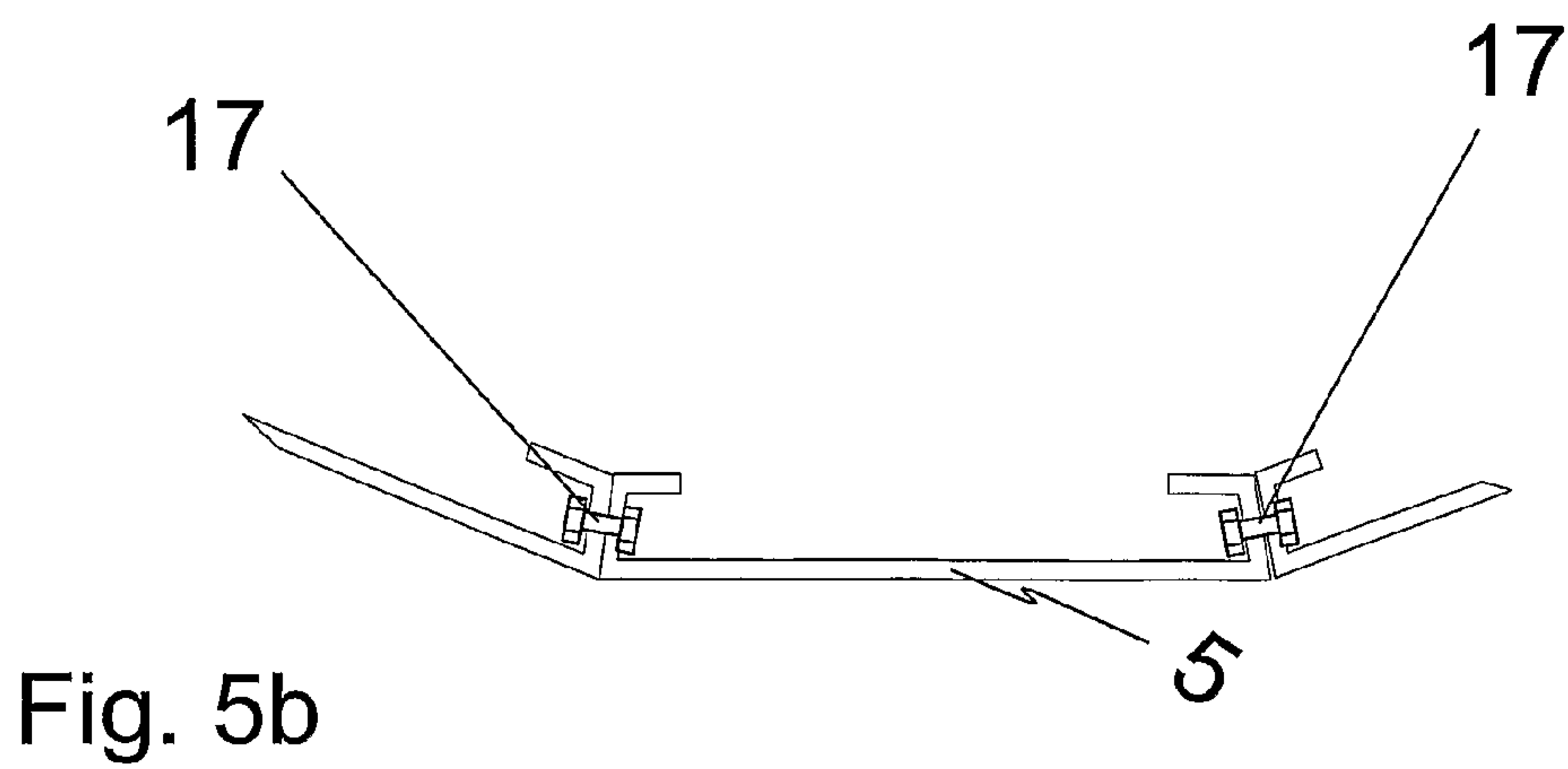
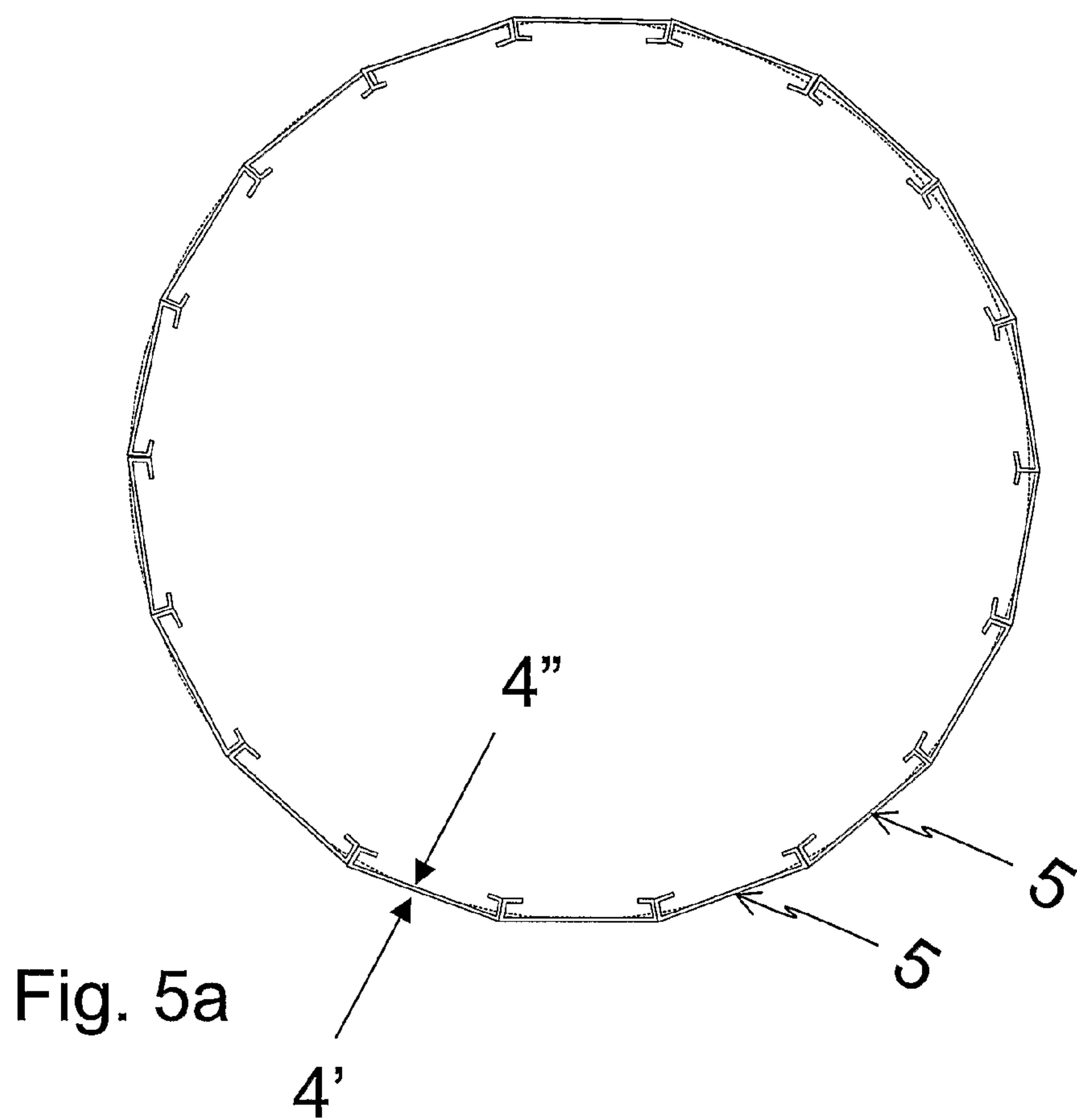

Fig. 4



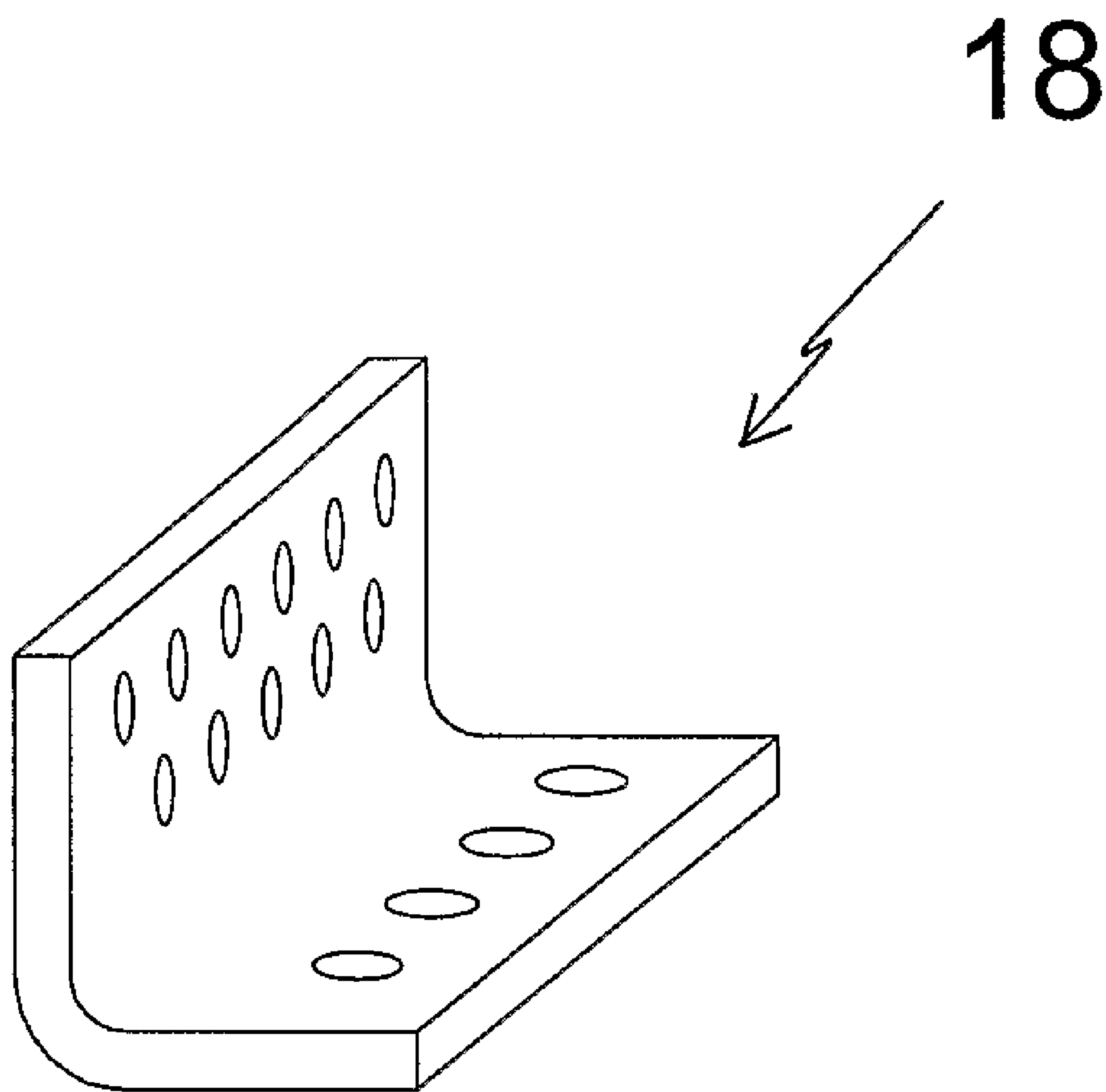

Fig. 6

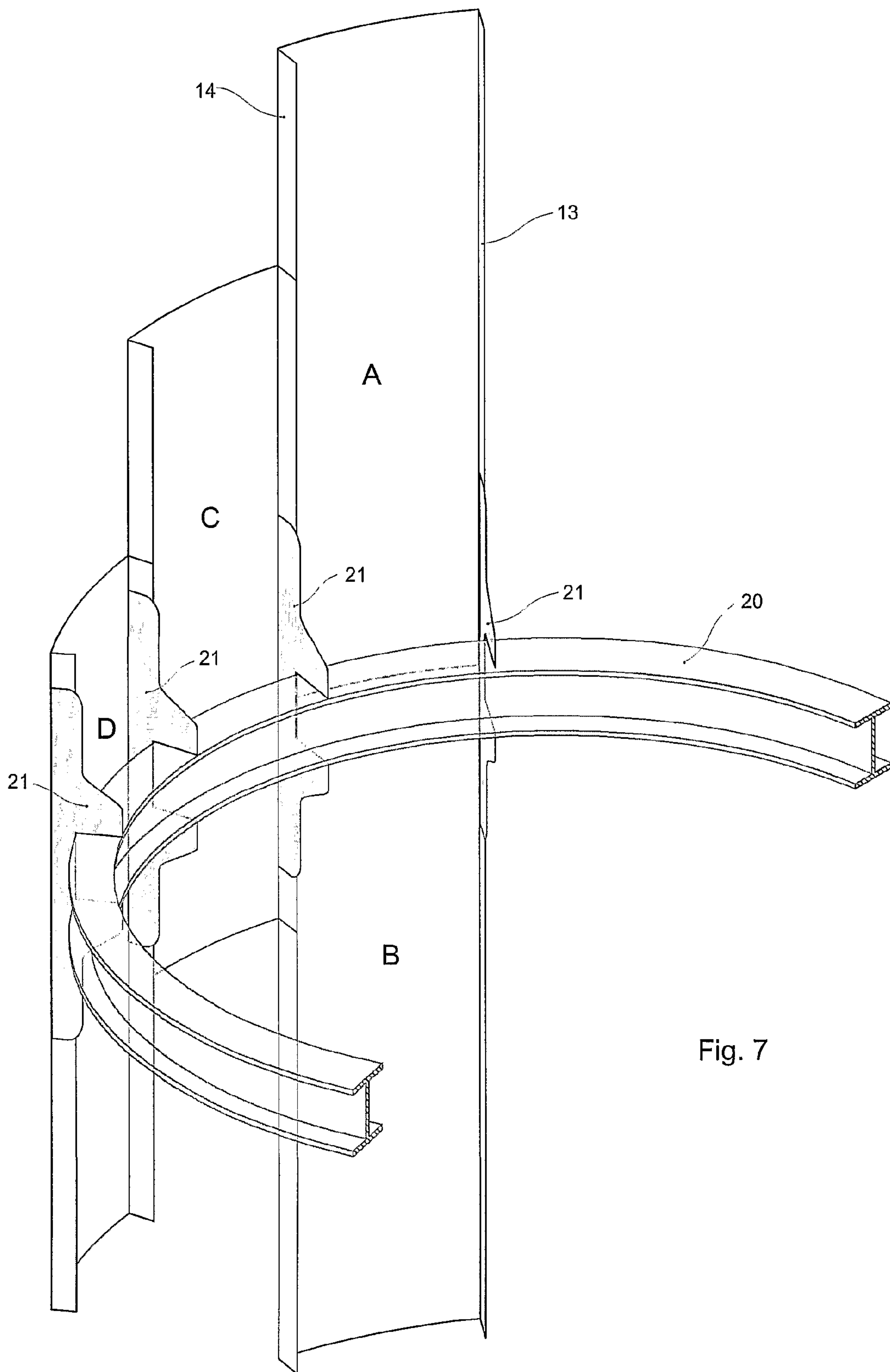

Fig. 7

**TOWER FOR A WIND TURBINE,
PREFABRICATED METAL WALL PART FOR USE
IN A TOWER FOR A WIND TURBINE AND
METHOD FOR CONSTRUCTING A TOWER FOR A
WIND TURBINE**

[0001] This invention relates to a tower for a wind turbine which has an exterior side and an interior side and which tower is at least partly composed of prefabricated metal wall parts. The invention also relates to a prefabricated metal wall part for use in a tower for a wind turbine. The invention further relates to a method for constructing a tower for a wind turbine which has an exterior side and an interior side and wherein the tower is at least partly composed of prefabricated metal wall parts.

[0002] An ongoing trend in the wind turbine market is the increasing power of the wind turbine in conjunction with increasing tower heights. Larger wind turbines imply an increase in size, weight and loads acting on the tower of the wind turbine. This requires the towers to be stronger and stiffer, and consequently lead to bigger tower dimensions.

[0003] Conventional tubular steel towers for wind turbines of 2 MW and above require very large tower diameters and/or large wall thickness to take the large static and fatigue loads which are exerted on the wind turbine. These large towers are usually constructed by prefabricating a number of tower sections from metal plate by welding curved plates together, often referred to as "cans", and transporting these sections to the site where the tower is to be erected. These sections or cans are bolted to the foundation of the tower and to each other using curved L-type flanges requiring a large number of large bolts. The increasing power of the wind turbines also require the flanges to be produced with an increasing accuracy as to flatness. For land transport, the diameter of the tower section is the main restriction. A diameter of about 4.3 m is usually the upper limit that can be transported to most locations in view of fly-overs etc., and the weight of the section imposes its limits as well.

[0004] In use, the forces exerted on the top of the tower by the rotor-turbine assembly determine the load, i.e. the bending moments at all essentially horizontal flange connections and welds. The ultimate strength is determined by the yield strength of the bolts and by the buckling strength of the tubular metal wall. For the fatigue strength the welds are critical. During service, it is very difficult to inspect the quality of a weld. Also, on-site repairs are awkward.

[0005] Apart from the strength, the dynamic behaviour of the tower is another determining factor. The turbine would be severely damaged if it were to operate at its natural resonance frequency. CONFIRMATION COPY

[0006] It is known to increase natural frequency and/or the strength and/or stiffness of a wind turbine by increasing the thickness of the metal plate and/or the diameter of the tower. However, transport problems due to size and weight of the tower sections make this solution impractical. Also lattice towers have been used to increase the stiffness of towers for wind turbines. However, lattice towers require a very large number (>2000) of individual parts, significant amounts of maintenance and are considered visually unattractive. Moreover, the dynamic behaviour of such towers is not adequate for large towers. Guyed towers have also been used for wind turbines. These towers are guyed with steel cables at about

half the height of the tower. Obviously, this poses a design problem as the cables may not come into contact with the rotor of the wind turbine. Moreover, the costs of the foundations for the cables and the cables itself (with diameters of about 100 mm) are high. Also the cables need to have high fatigue strength.

[0007] Hybrid towers, such as towers with concrete walls, poured between an inner and outer steel shell have also been proposed. The problem is to assure the quality of the wall, once it has been poured. When constructing a tower for a wind turbine using prefabricated concrete elements, tension means are required to keep the concrete wall under compressive forces. Moreover, concrete towers are not an economical solution.

[0008] It is the object of this invention to provide a tower for a wind turbine which provides a large stiffness. It is another object of this invention to provide a tower for a wind turbine which provides sufficient strength to enable application of high power generators on top of the tower. It is still another object of this invention to provide a tower for a wind turbine which does not cause the aforementioned transport problems, even for very large towers and/or towers with a wide base.

[0009] According to a first aspect of the invention, one or more of these objects can be reached by a tower for a wind turbine wherein the tower has an exterior side and an interior side and wherein the tower is at least partly composed of prefabricated metal wall parts wherein each wall part comprises an essentially quadrangular portion having an outwardly facing surface in the direction of the exterior of the tower and an inwardly facing surface in the direction of the interior of the tower, said portion having a top edge, a bottom edge, a first side edge and a second side edge, wherein the first side edge is provided with a first flange along at least part of the length of the first side edge and wherein the second side edge is provided with a second flange along at least part of the length of the second side edge. By using the prefabricated metal wall parts according to the invention, the stiffness of the construction is increased by the presence of the flanges of the prefabricated metal wall parts, which act as a rib. By using prefabricated metal wall parts, the transport of complete tower sections is no longer required, thus solving the transport problem. The prefabricated metal wall parts are easy to transport with ordinary transport means such as trucks. Also, by using the prefabricated parts, the size of the tower at the foundation is no longer limited by the transport restrictions and a wider base can be used. It also allows construction of higher towers because the size of the base is no longer an issue. The wider base results in a lower local pressure on the foundation, thus enabling to use a simpler foundation. The wider base also contributes to the stiffness of the tower, thereby enabling to use high power generators on top of the tower. In an embodiment of the invention the tower is substantially composed of prefabricated metal wall parts. The tower according to this embodiment relies on prefabricated metal wall parts as the load bearing elements, and are readily distinguishable from concrete towers, where a wall part serves as a mould for the concrete to be poured in and where, after setting, the concrete serves as the main load bearing material. It should be noted that the tower according to the invention does not comprise concrete as a load bearing material at the location of the prefabricated metal wall parts.

It should also be noted that it is possible to construct a tower according to the invention on top of a concrete foundation or base wherein the concrete base extends upwardly, the base forming the lower part of the tower, and a tower according to the invention forming the upper part of the tower.

[0010] In an embodiment of the invention the first flanges and the second flanges of the prefabricated metal wall parts extend towards the interior side of the tower. This enables to produce a tower where the rib, formed by the adjacent flanges, is located on the inside of the tower, leaving a smooth exterior appearance. A smooth exterior leads to a reduced impact of wind force on the tower and a smooth exterior is considered to be visually more attractive.

[0011] In an embodiment of the invention, the prefabricated metal wall parts having a height and a width, at least two of the prefabricated metal wall parts have a height which is about 2.5 times larger than the width of the bottom edge, preferably more than five times larger, more preferably more than 10 times larger. It should be noted that the height of the prefabricated metal wall parts is to be understood to be the distance between the bottom edge and the top edge of the prefabricated metal wall parts when present in the tower. It should be understood that the length direction is defined in the direction of the height of the tower. This means that the tower comprises prefabricated metal wall parts which are considerably higher than wide, thus resulting in long side edges of the essentially quadrangular portion of the prefabricated metal wall parts and thereby enabling long flanges being provided at least partly on the side edge thereof. These long flanges enable a large stiffening potential of the tower.

[0012] In an embodiment of the invention the first flange of a prefabricated metal wall part is attached to the second flange of an adjacent second prefabricated metal wall part by fastening means. The flanges are now fixedly connected, thereby increasing the stiffening potential because of the double thickness of the rib. Fastening means comprise for instance a weld or a rivet. In a preferred embodiment of the invention, the fastening means comprise nuts and bolts. This enables to fasten quickly the first and second flange of two adjacent panels to each other. The holes required for the bolts to be inserted into may already be present in the prefabricated metal wall parts or may be drilled at the site where the connection between the adjacent panels is made. The use of nuts and bolts also enables to temporarily undo the connection, for instance to remove a prefabricated metal wall part from the construction, or to replace a prefabricated metal wall part. It also allows easy on-site and/or off-site inspection.

[0013] In an embodiment of the invention the essentially quadrangular portion of the prefabricated metal wall parts is preferably orthogonal or trapezoidal wherein the length of the first side edge is approximately equal to the length of the second side edge and wherein the bottom edge is longer than the top edge. In case of constructing an essentially cylindrical tower, the use of orthogonal prefabricated metal wall parts is called for, in case of constructing a conical tower, trapezoidal prefabricated metal wall parts are called for. Conical towers enable to construct a tower with a large base and become slimmer with increasing height of the tower. Tapering can be over the entire height of the tower or over part of the length of the tower. The latter can also be achieved by using prefabricated metal wall parts to form essentially

cylindrical tower sections and by using prefabricated metal wall parts to form essentially conical tower sections and combine these tower sections into one tower.

[0014] Kinked prefabricated metal wall parts may be used in the upper levels of a conically tapered tower or tower section for a wind turbine wherein the lower levels are made using prefabricated metal wall parts with an essentially flat quadrangular portion, thus reducing the number of prefabricated metal wall parts required for a full ring. One prefabricated metal wall part with one kink in the essentially quadrangular portion in a given upper level ring will link up with two prefabricated metal wall parts which have an essentially flat quadrangular portion in the ring immediately below the upper level ring. In case the kinked prefabricated metal wall parts contains more kinks, it may link up with a corresponding number of prefabricated metal wall parts with an essentially flat quadrangular portion. It will be clear that kinked prefabricated metal wall parts in a lower level can also be combined with kinked prefabricated metal wall parts in the upper level.

[0015] In an embodiment of the invention the tower has an essentially annular, preferably essentially circular horizontal cross-section. An essentially annular horizontal cross section is also obtained if a polygonal horizontal cross section is taken with a large number of facets such as a pentagon or hexagon.

[0016] In an embodiment of the invention the essentially quadrangular portion of the prefabricated metal wall parts are curved with a radius corresponding to the radius of the tower at the position of the location of the prefabricated metal wall part. This allows constructing a tower with a smooth curvature, and in case the first and second flanges extend towards the interior side of the tower, the exterior of the tower will be smooth. In another embodiment of the invention the quadrangular portion of the first prefabricated metal wall parts is essentially flat. The use of an essentially flat quadrangular portion has the advantage that there is no need for a locally dependent curvature in the quadrangular portion and is therefore easier to produce. It is also more convenient during transport of the prefabricated metal wall parts. The application of such prefabricated metal wall parts causes the exterior of the tower to be polygonal. In still another embodiment the essentially flat quadrangular prefabricated metal wall parts also comprises at least one kink essentially in the direction between the bottom edge and the top edge of the prefabricated metal wall part. The kink (or kinks) therefore runs in the direction of the height of the tower. With the kink (or kinks) a higher buckling stiffness of the prefabricated metal wall part is obtained. It may also increase the number of facets of the polygonal thereby achieving a smoother exterior of the tower.

[0017] The invention is also embodied in a tower for a wind turbine as described hereinabove wherein the first flange is provided with an additional first flange along at least part of the length of the first flange and/or wherein the second flange is provided with an additional second flange along at least part of the length of the second flange. This is advantageous for instance for a further increase in stiffening the tower, particularly when the first flange and second flange are both provided with an additional flange, wherein the first flange with its respective additional flange preferably essentially forms an L-shape and/or wherein the second

flange with its respective additional flange preferably essentially forms an L-shape. For the purpose of this application, these additional flanges on the first and/or second flanges may be used to attach objects thereto such as stairs, or internal floors.

[0018] The invention is also embodied in a tower for a wind turbine as described hereinabove wherein the first and/or second flanges are at least partly folded back towards the inwardly facing surface of the essentially quadrangular portion of the prefabricated metal wall part, thereby effectively doubling the thickness of the flanges. This doubling of the flanges causes an additional stiffening of the construction. It will be clear to the skilled person that the flange could also be folded back twice or more contributing to the stiffening effect.

[0019] In an embodiment of the invention the prefabricated metal wall parts are steel parts, preferably high strength steel parts, for instance having a yield strength of about 355 MPa or higher. The use of steel enables to use prefabricated metal wall parts of a small thickness, which reduces the weight of the tower. The use of high strength steel prefabricated metal wall parts enables a further reduction in weight of the tower. As a result, the foundation of the tower can be constructed more efficient.

[0020] In an embodiment of the invention the first flange of a first prefabricated metal wall part is vertically staggered attached to the second flange of an adjacent second prefabricated metal wall part by fastening means. This application of prefabricated metal wall parts by a stretching bond type connection of the flanges of two adjacent prefabricated metal wall parts also requires the application of prefabricated metal wall parts of different lengths, at least in the first and last ring of the tower or tower section. The application of this staggered connection has the advantage over constructing the tower from rings of connected non-staggered connected prefabricated metal wall parts that the forces are lead through the construction without having to be led through horizontal flanges which connect the aforementioned rings. The overlap at the edges between the staggered connected prefabricated metal wall parts is between 1:2 and 1:4, preferably about 1:3, meaning that about $\frac{1}{2}$ to $\frac{3}{4}$, preferably about $\frac{2}{3}$ of the respective side edges of adjacent prefabricated metal wall parts overlap.

[0021] In another embodiment of the invention the circumference of the tower consists of n adjacently positioned prefabricated metal wall parts, wherein the angle between the first flange and the second flange is $360/n$.

[0022] According to a second aspect of the invention, the prefabricated metal wall part for use in a tower for a wind turbine as described hereinabove is characterised in that the prefabricated metal wall part comprises an essentially quadrangular portion having an outwardly facing surface and an inwardly facing surface, said portion having a top edge, a bottom edge, a first side edge and a second side edge, wherein the first side edge is provided with a first flange along at least part of the length of the first side edge and wherein the second side edge is provided with a second flange along at least part of the length of the second side edge.

[0023] According to a third aspect of the invention, a method is provided for constructing a tower for a wind

turbine as described hereinabove, wherein the tower is at least partly composed of prefabricated metal wall parts as described hereinabove.

[0024] When constructing a tower according to the invention, there is no need for a high capacity crane to lift the tower sections on top of each other at the site where the tower is constructed. A relatively small building crane will be adequate to lift one prefabricated metal wall parts at a time, except in the case tower complete tower sections are built from the prefabricated metal wall parts which are then hoisted upon the foundation or the tower section already present. In that case a more powerful crane is required.

[0025] The absence of horizontal welds in the towers according to the invention eliminates a known source of fatigue failure, thereby allowing to relieve design restrictions for instance by allowing to use thinner gauge metal plate. The locations where a bottom edge of a first prefabricated metal wall part touches a top edge of a prefabricated metal wall part which is located immediately below the first prefabricated metal wall part can be sealed by using sealing means, for instance a sealant. This prevents the outside atmosphere to enter the structure and prevents corrosion. The locations where the first flange of a prefabricated metal wall part is connected to the second flange of the adjacent prefabricated metal wall part can, if so desired, also be sealed using sealing means, such as a sealant.

[0026] In an embodiment of the invention the tower is provided with stiffening means, such as one or more preferably substantially horizontal stiffening rings. These stiffening means are preferably provided in the interior of the tower to absorb the horizontal forces exerted on the tower. These stiffening means may be provided at different heights of the tower. The prefabricated metal wall parts are connected to the ring, thereby obtaining an increased stiffness of the tower. Additional connecting struts may be used to connect the prefabricated metal wall parts to the ring. The stiffening means may also be formed by internal floors, or the stiffening means, such as a stiffening ring along internal circumference of the tower, may provide the base for the internal floor or floors. The stiffening means may also contribute to the even distribution of forces and loads over the entire circumference of the tower.

[0027] The prefabricated metal wall parts can be produced for example from hot-rolled metal using commonly known technology. The hot-rolled metal may be plate material or coiled material. This material, after optional leveling can be cut to the desired dimensions and shape, and the flanges can be formed on the edges of the essentially quadrangular portion of the prefabricated metal wall parts using conventional bending techniques. The optional curvature of the essentially quadrangular portion of the prefabricated metal wall parts or the kink or kinks can likewise be easily introduced. The prefabricated metal wall parts may be coated prior to use in the tower e.g. with zinc and/or an organic coating to extend the service life and to reduce maintenance.

[0028] The prefabricated metal wall parts may also comprise additional built-in functionality such as a door for entering the interior of the tower. Internal structures like stairs and floors can be easily installed.

[0029] The present invention will now be further explained by the following non-limitative drawings and examples.

[0030] In these drawings:

[0031] FIG. 1 is a schematic representation of a wind turbine;

[0032] FIG. 2 is a schematic representation of a tower for a wind turbine according to the state of the art (not to scale);

[0033] FIG. 3 is a schematic representation of towers for a wind turbine according to the invention (not to scale);

[0034] FIG. 4 is a schematic representation of a prefabricated metal wall parts according to the invention (not to scale);

[0035] FIG. 5 is a schematic cross-section of the first ring of a tower for a wind turbine also highlighting a schematic representation of the bolted connection;

[0036] FIG. 6 is a schematic representation of an L-shaped flange.

[0037] FIG. 7 is a schematic representation of the tower construction at the location of a stiffening ring.

[0038] In FIG. 1 a schematic representation of a wind turbine 1 is shown. The wind turbine 1 comprises a generator 2, a rotor 3 and a tower 4 onto which the combination of the generator and the rotor is mounted. The tower 4 has an exterior surface which forms the outside of the tower 4 and an interior surface which forms the inside of the tower. The tower consists of four tower sections 4a-4d. The wind turbine is placed on a foundation 19.

[0039] In FIG. 2 a tower 4 for a wind turbine according to the state of the art is shown. Tower segments 4a, 4b, 4c and 4d are mounted on top of each other. These tower segments are made off-site and connected through horizontal flanges and large bolts and nuts. These flanges are indicated schematically by the thick horizontal lines between the tower sections. The tower segments are made from curved plates which are welded together horizontally and vertically. These welds, indicated with the dashed lines, are known to be a possible source of fatigue failure, particularly the horizontal welds. For a tower of about 80 m high, a base of about 4.3 m and a top diameter of about 2.3 m is commonly used. The dimension of the base is limited by transport limitations.

[0040] In FIG. 3a a tower 4 for a wind turbine according to the invention is shown, wherein the staggered prefabricated metal wall parts each stagger over about half the length of the neighbouring prefabricated metal wall part and FIG. 3b shows a tower wherein the staggered prefabricated metal wall parts each stagger over about a third of the length of the neighbouring prefabricated metal wall part. The base of the tower is about 6.5 m in diameter whereas the top of the tower has a diameter of about 2.3 m. The 6.5 m base diameter poses no transport problems because it can be transported to the building site in pieces. The increase in width of the base of the tower increases the stiffness of the tower. It also enables to construct higher towers with adequate stiffness to install high power wind turbines.

[0041] FIG. 4a shows an embodiment of a prefabricated metal wall part 5 according to the invention for use in a tower 4 for a wind turbine 1 as described hereinabove. The prefabricated metal wall part 5 is characterised in that the wall part comprises an essentially quadrangular portion 6 having an outwardly facing surface 7 facing the exterior of the tower and an inwardly facing surface 8 facing the interior

of the tower, said portion having a top edge 9, a bottom edge 10, a first side edge 11 and a second side edge 12, wherein the first side edge 11 is provided with a first flange 13 along at least part of the length of the first side edge 11 and wherein the second side edge 12 is provided with a second flange 14 along at least part of the length of the second side edge 12. The first flange 13 is provided with an additional first flange 15 which essentially forms an L-shape with the first flange 13 and the second flange 14 is provided with an additional second flange 16 which essentially forms an L-shape with the second flange 14. The prefabricated metal wall parts are not drawn to scale. The cross section A-A is shown in FIG. 4b. Typical dimensions for such a prefabricated metal wall parts for the lower ring of a conical tower or tower segment would be a width at the top edge 9 of between about 0.60 and 1.00 m, for example about 0.86 m, a width at the bottom edge 10 of between about 1.30 and 0.70 m, for example about 1.04 m, a height of between about 10 and 20 meters, for example 20 meters, and a height of the extending first flange 13 and second flange 14 of between 0.10 and 0.20 m, for example about 0.15 m. A typical thickness of the prefabricated metal wall parts would be between 8 and 16 mm, for example about 12 mm.

[0042] In FIG. 5a a schematic cross section of the first ring of a tower for a wind turbine is shown. The essentially circular cross-section of the tower in this example is composed of eighteen prefabricated metal wall parts 5. The exterior of the tower is indicated by 4', the interior of the tower is indicated by 4". In this embodiment of the invention, the first flange of each prefabricated metal wall parts is attached to the second flange of the adjacent prefabricated metal wall parts by bolts and nuts which are passed through holes in the first and second flange. FIG. 5b shows a part of the first ring with the prefabricated metal wall parts 5 and the nuts and bolts 17.

[0043] In FIG. 6 a schematic representation is shown of the L-shaped flange 18 which can be used to attach prefabricated metal wall parts of the first ring to the foundation 19 of the tower, or to the top ring on which the generator is attached.

[0044] In FIG. 7 a schematic representation of part of the tower construction at the location of a stiffening ring is shown. The adjacent, staggeredly connected prefabricated metal wall parts are connected using an overlap at the edges (i.e. in a stretcher-bond type connection) of 1:3 and are also connected to the stiffening ring 20 using connecting struts 21. As shown, these connecting struts 21 are connected to the flanges 13, 14 (see FIG. 4) of the prefabricated metal wall parts on one side, and to the stiffening ring 20 on the other side. In FIG. 7 four prefabricated metal wall parts are shown which are indicated with A, B, C and D. The lower edge of part A and the upper edge of part B are adjacent. The first side edge of part A is adjacent and connected to the second side edge of part C by their adjacent flanges and fastening means (not shown). The connecting struts 21 extend above and below the stiffening ring 20, thereby enabling fixedly connecting the side edges of upper part A to the side edges of lower part B. Due to the 1:3 overlap in this example only about 1/3 of the circumference of the tower has a horizontal seam at or near the location of the stiffening ring. In the example of FIG. 8 the horizontal seam between part A and B is located near the stiffening ring 20.

[0045] To construct a tower for a wind turbine according to the invention it is possible to first form a full ring of the tower by attaching at least two adjacent prefabricated metal wall parts along their adjacent flanges. This first full ring can be connected to an essentially flat and essentially horizontal foundation for the tower. Of course, the same result is obtained when starting with a first prefabricated metal wall part which is attached to the foundation after which a second prefabricated metal wall part is attached to the first prefabricated metal wall part and the foundation. Similarly, the following full ring can be constructed upon the ring already present by first building the entire ring and subsequently lifting is on top of the ring already present, or by connecting prefabricated metal wall parts to the ring already present and to each other one by one, the former procedure requiring a larger capacity crane than the latter procedure. Rings are added to the rings already present until the desired height of the tower is obtained.

[0046] The connection between the first full ring and the foundation may be achieved by using a flange that is connected to the foundation. In case of using prefabricated metal wall parts with an essentially flat or kinked quadrangular portion, the flanges may be simple L-shaped flanges. In case of using prefabricated metal wall parts with a curved quadrangular portion, the flanges should have a corresponding curvature.

[0047] To construct a tower for a wind turbine according to the invention it is possible to first form a full ring of the tower by attaching at least two adjacent prefabricated metal wall parts along their adjacent flanges vertically staggeredly. This implies the use of prefabricated metal wall parts of different lengths. In the example of FIG. 3a, full length prefabricated metal wall parts are combined with prefabricated metal wall parts of half that length whereas in the example of FIG. 3b, full length prefabricated metal wall parts are combined with prefabricated metal wall parts of $\frac{2}{3}$ and $\frac{1}{3}$ of that length (i.e. an overlap of 1:3). Of course, it is also possible to stagger the prefabricated metal wall parts differently than those mentioned in FIG. 3. These embodiments are also considered to be part of the invention. After the first full ring has been completed and connected to the foundation, the remainder of the tower is constructed using essentially full length prefabricated metal wall parts. In the last full ring prefabricated metal wall parts of different lengths have to be used to make the top edge of the last ring level. Of course it is also possible to use prefabricated metal wall parts of non-full length elsewhere in the tower if so desired. This staggeredly attaching the prefabricated metal wall parts provides in a large stiffness of the tower, without introducing horizontal fully annular or circular flanges to connect tower sections.

[0048] When constructing a tower according to the invention, the tower may be constructed top down by starting to construct the top of the tower whilst being suspended onto a yoke construction, the yoke construction being provided with lifting means, such as a hydraulic jack. By first completing a full ring of the tower, preferably by connecting the prefabricated metal wall parts staggeredly, only just above ground level, and subsequently lifting the ring using the yoke and jacks, the following parts can also be mounted just above ground level. This way, there is no need for very high cranes during the construction of the tower, and the construction can be largely performed just above ground level,

where wind forces are usually more moderate than high in the air. Also, correction of any misalignment is easier to perform. Another advantage of this top-down or push-up method is that it is more practical to fit a stiffening ring from below in a tapered construction and simultaneously using it to align the prefabricated metal wall parts and to optionally correct any misalignment.

[0049] It is of course to be understood that the present invention is not in any way limited to the described embodiments and examples described above, but encompasses any and all embodiments within the scope of the description and the following claims.

1. Tower for a wind turbine having an exterior side and an interior sides,

the tower at least partly comprising prefabricated metal wall parts,

wherein each wall part comprises an essentially quadrangular portion having an outwardly facing surface in the direction of the exterior of the tower and an inwardly facing surface in the direction of the interior of the tower,

said portion having a top edge, a bottom edge, a first side edge and a second side edge,

wherein the first side edge is provided with a first flange along at least part of the length of the first side edges, and

wherein the second side edge is provided with a second flange along at least part of the length of the second side edge.

2. Tower for the wind turbine according to claim 1, wherein the first flanges and the second flanges of the prefabricated metal wall parts extend towards the interior side of the tower.

3. Tower for the wind turbine according to claim wherein each of the prefabricated metal wall parts have a height and a width, and wherein at least two of the prefabricated metal wall parts have a height which is at least about 2.5 times larger than the width of the bottom edge.

4. Tower for the wind turbine according to claim 1, wherein the first flange of a said prefabricated metal wall part is attached to the second flange of an adjacent said prefabricated metal wall part by fastening means.

5. Tower for the wind turbine according to claim 1,

wherein the essentially quadrangular portion of the prefabricated metal wall parts is essentially rectangular wherein the length of the first side edge is approximately equal to the length of the second side edge and wherein the bottom edge is approximately equal to the length of the top edge, or

wherein the essentially quadrangular portion of the prefabricated metal wall parts is essentially trapezoidal wherein the length of the first side edge is approximately equal to the length of the second side edge and wherein the bottom edge is longer than the top edge.

6. Tower for the wind turbine according to claim 1 wherein the tower has an essentially annular, horizontal cross-section.

7. Tower for the wind turbine according to claim 1, wherein the essentially quadrangular portion of the respective prefabricated metal wall parts are curved.

8. Tower for the wind turbine according to claim 1, wherein the essentially quadrangular portion of the respective prefabricated metal wall part is essentially flat.

9. Tower for the wind turbine according to claim 1, wherein the first flange is provided with an additional first flange and/or wherein the second flange is provided with an additional second flange.

10. Tower for the wind turbine according to claim 1, wherein the first flanges and/or the second flanges are at least partly folded back towards the inwardly facing surface of the essentially quadrangular portion of the prefabricated metal wall part for at least partly doubling the thickness of the first flanges and/or second flanges.

11. Tower for the wind turbine according to claim 1, wherein the prefabricated metal wall parts are steel parts.

12. Tower for the wind turbine according to claim 1, wherein the first flange of at least one said prefabricated metal wall part is vertically staggeredly attached to the second flange of an adjacent said prefabricated metal wall part by fastening means.

13. Tower for the wind turbine according to claim 1, wherein the circumference of the tower consists of n adjacently positioned prefabricated metal wall parts, wherein the angle between the first flange and the second flange is $360/n$.

14. Tower for the wind turbine according to claim 1, wherein the tower is provided with stiffening means.

15. Prefabricated metal wall parts for use in a tower for a wind turbine at least partly composed of a plurality of said prefabricated metal wall parts, comprising:

an essentially quadrangular portion having an outwardly facing surface and an inwardly facing surface,

said portion having a top edge, a bottom edge, a first side edge and a second side edge,

wherein the first side edge is provided with a first flange along at least part of the length of the first side edge, and

wherein the second side edge is provided with a second flange along at least part of the length of the second side edge.

16. Method for constructing a tower for a wind turbine according to claim 1 at least partly composed of said prefabricated metal wall parts, comprising attaching one said prefabricated metal wall part to an adjacent said prefabricated wall part.

17. Tower for the wind turbine according to claim 1, wherein each of the prefabricated metal wall parts have a height and a width, and wherein at least two of the prefabricated metal wall parts have a height which is more than five times larger than the width of the bottom edge.

18. Tower for the wind turbine according to claim 1, wherein each of the prefabricated metal wall parts have a height and a width, and wherein at least two of the prefabricated metal wall parts have a height which is more than ten times larger than the width of the bottom edge.

19. Tower for the wind turbine according to claim 1, wherein the first flange of a said prefabricated metal wall part is attached to the second flange of an said adjacent prefabricated metal wall part by fastening means comprising nuts and bolts.

20. Tower for the wind turbine according to claim 1, wherein the tower has an essentially circular horizontal cross-section.

21. Tower for the wind turbine according to claim 1, wherein the essentially quadrangular portion of the respective prefabricated metal wall part is essentially flat, and wherein the essentially quadrangular portion of the respective prefabricated metal wall part also comprises at least one kink essentially in the direction between the bottom edge and the top edge of the prefabricated metal wall part.

22. Tower for the wind turbine according to claim 1, wherein the prefabricated metal wall parts are high strength steel parts.

23. Tower for the wind turbine according to claim 1, wherein the first flange of at least one said prefabricated metal wall part is vertically staggeredly attached to the second flange of an adjacent said prefabricated metal wall part by fastening means, wherein more than half of the adjacently positioned prefabricated metal wall parts are attached vertically staggeredly.

24. Tower for the wind turbine according to claim 1, wherein the tower is provided with stiffening means comprising one or more stiffening rings.

25. Tower for the wind turbine according to claim 1, wherein the tower is provided with stiffening means comprising one or more substantially horizontal stiffening rings.

* * * * *