

US 20070175663A1

(19) **United States**

(12) **Patent Application Publication**
Rotthaeuser

(10) **Pub. No.: US 2007/0175663 A1**

(43) **Pub. Date: Aug. 2, 2007**

(54) **MEASURING DEVICE AND DRILLING
DEVICE FOR DEEP DRILLINGS**

(30) **Foreign Application Priority Data**

Jan. 22, 2004 (DE)..... 10 2004 003 481.8

(75) Inventor: **Magdalena Rotthaeuser**, Haltern am
See (DE)

Publication Classification

Correspondence Address:
ROBERTS, MLOTKOWSKI & HOBBS
P. O. BOX 10064
MCLEAN, VA 22102-8064 (US)

(51) **Int. Cl.**
E21B 47/00 (2006.01)

(52) **U.S. Cl.** **175/40; 175/320**

(73) Assignee: **DTB Patente GmbH**, Haltern am See
(DE)

(57) **ABSTRACT**

(21) Appl. No.: **10/596,575**

(22) PCT Filed: **Dec. 31, 2004**

(86) PCT No.: **PCT/EP04/14877**

§ 371(c)(1),
(2), (4) Date: **Jun. 16, 2006**

In order to obtain information on the drilling site in the case of deep wells quickly and precisely, a measuring device (6) having an electrically operated measuring unit for measuring relevant data relating to the rock, the drilling mud and/or the raw material to be obtained is proposed, the measuring device (6) being designed for supplying electrical energy via the drill column (3) and for data transfer to the surface likewise via the drill column (3).

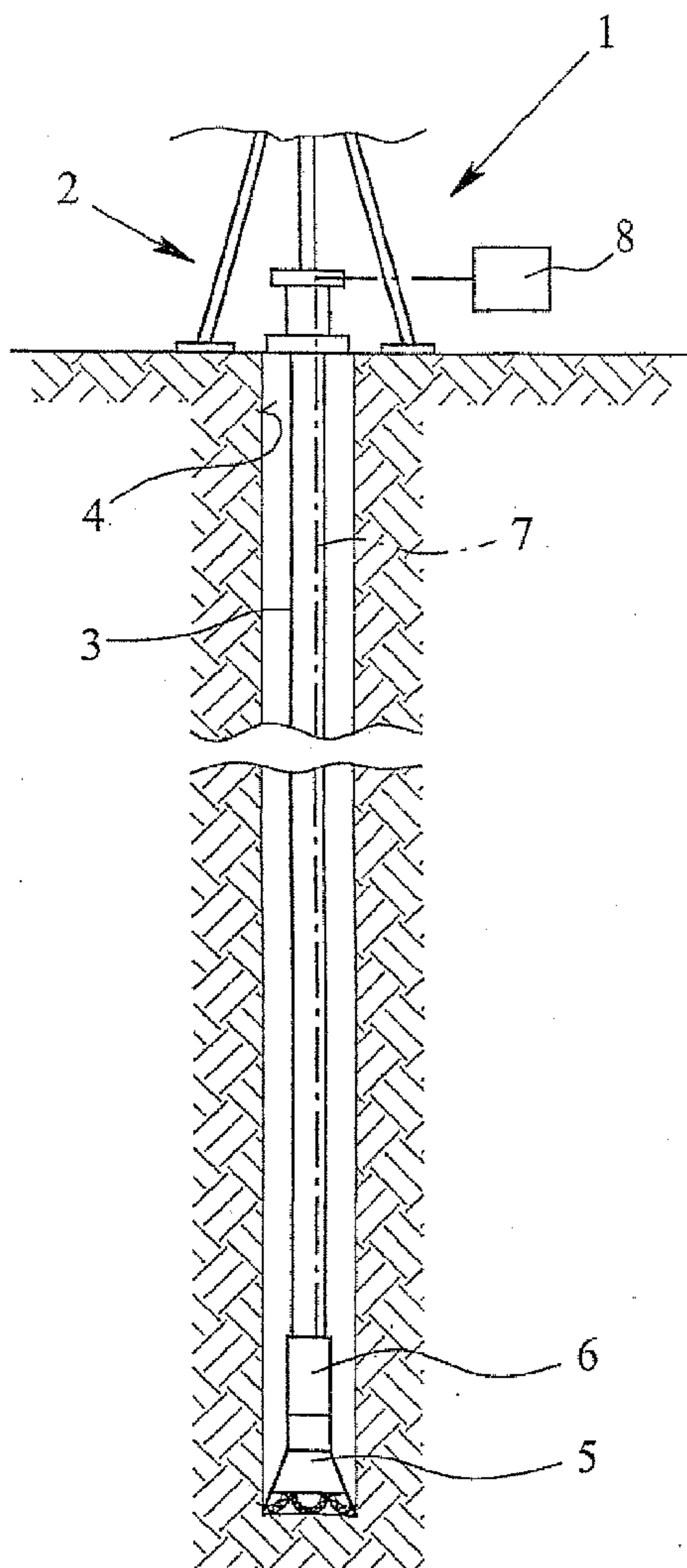

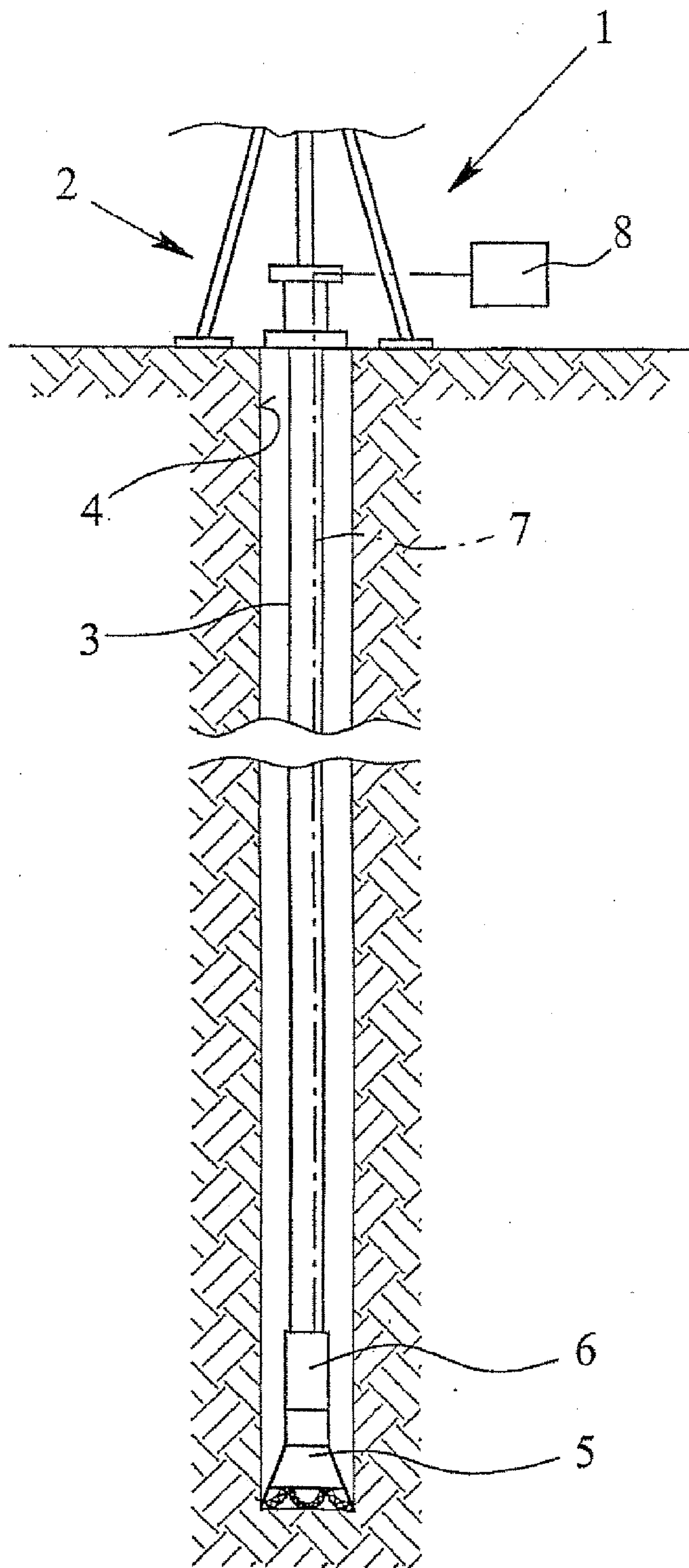

Fig. 1

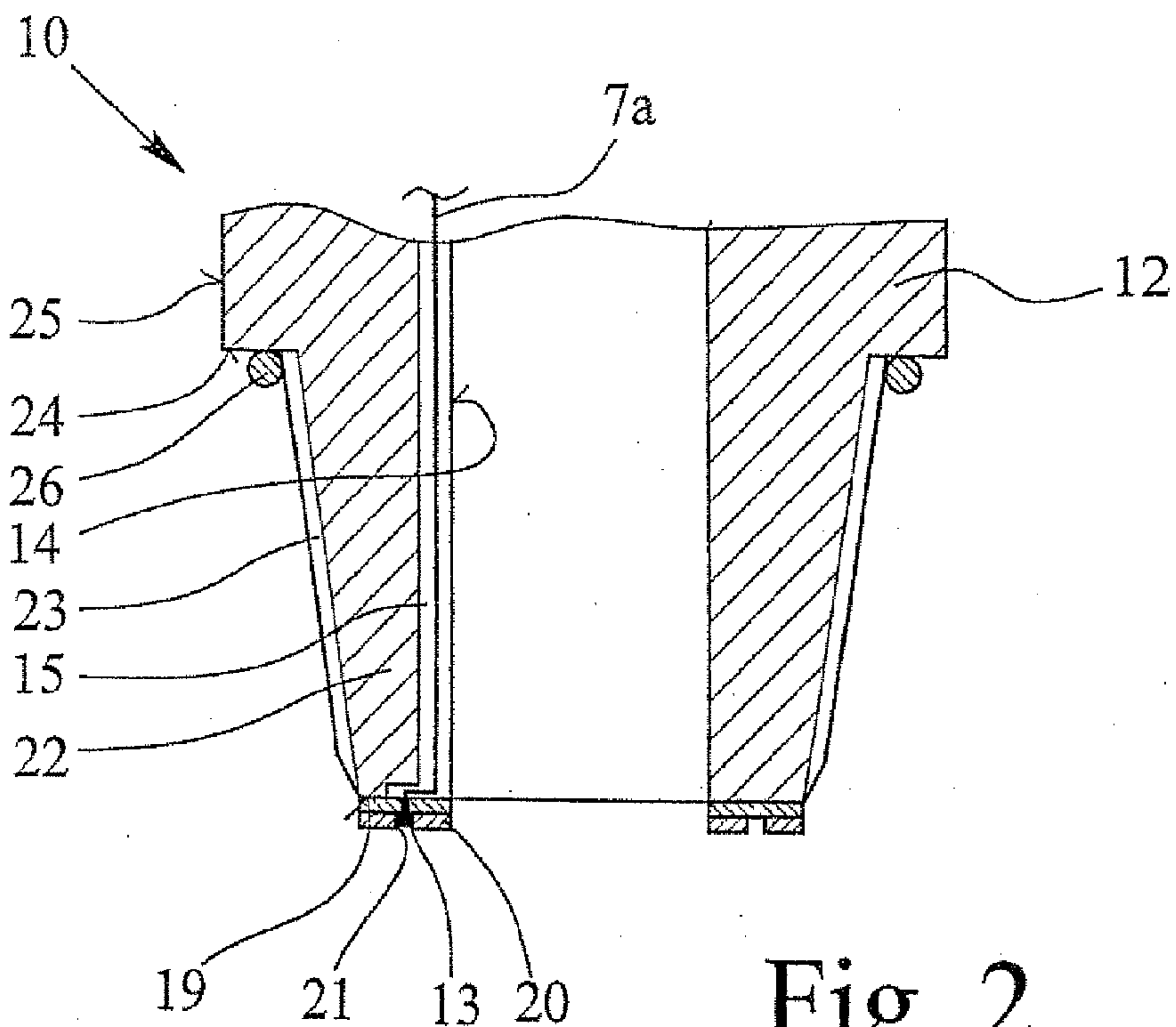

Fig. 2

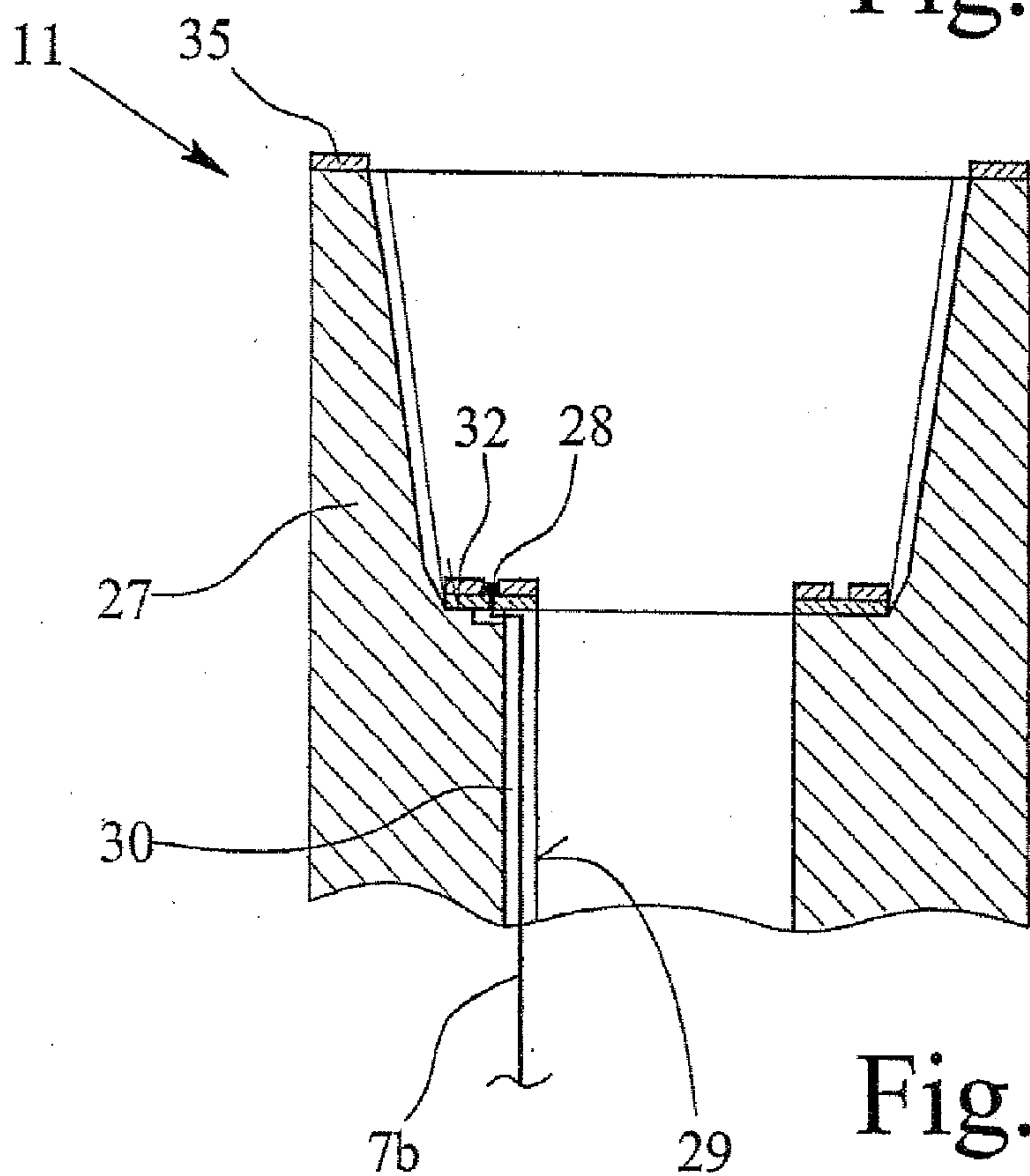

Fig. 3

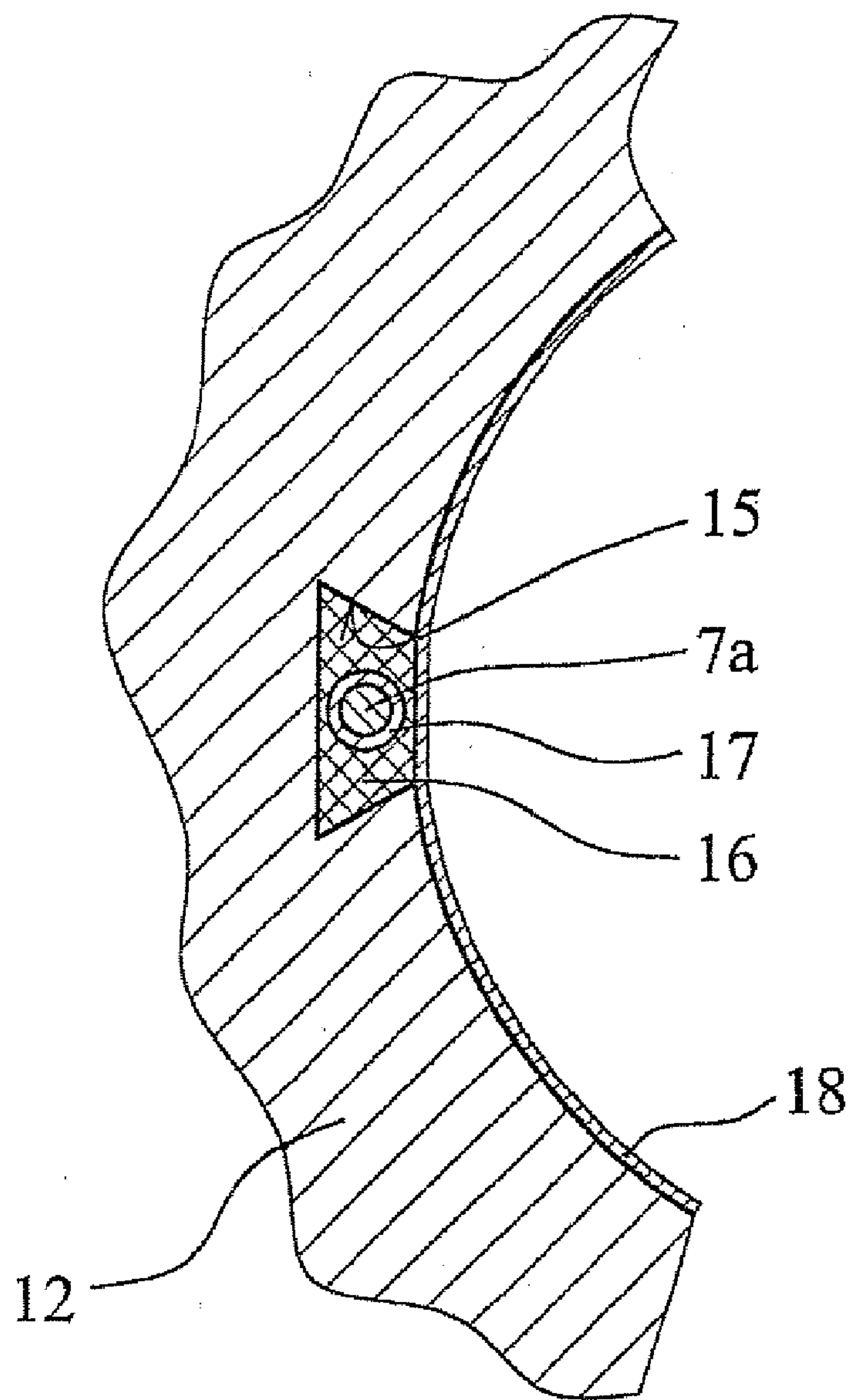

Fig. 4

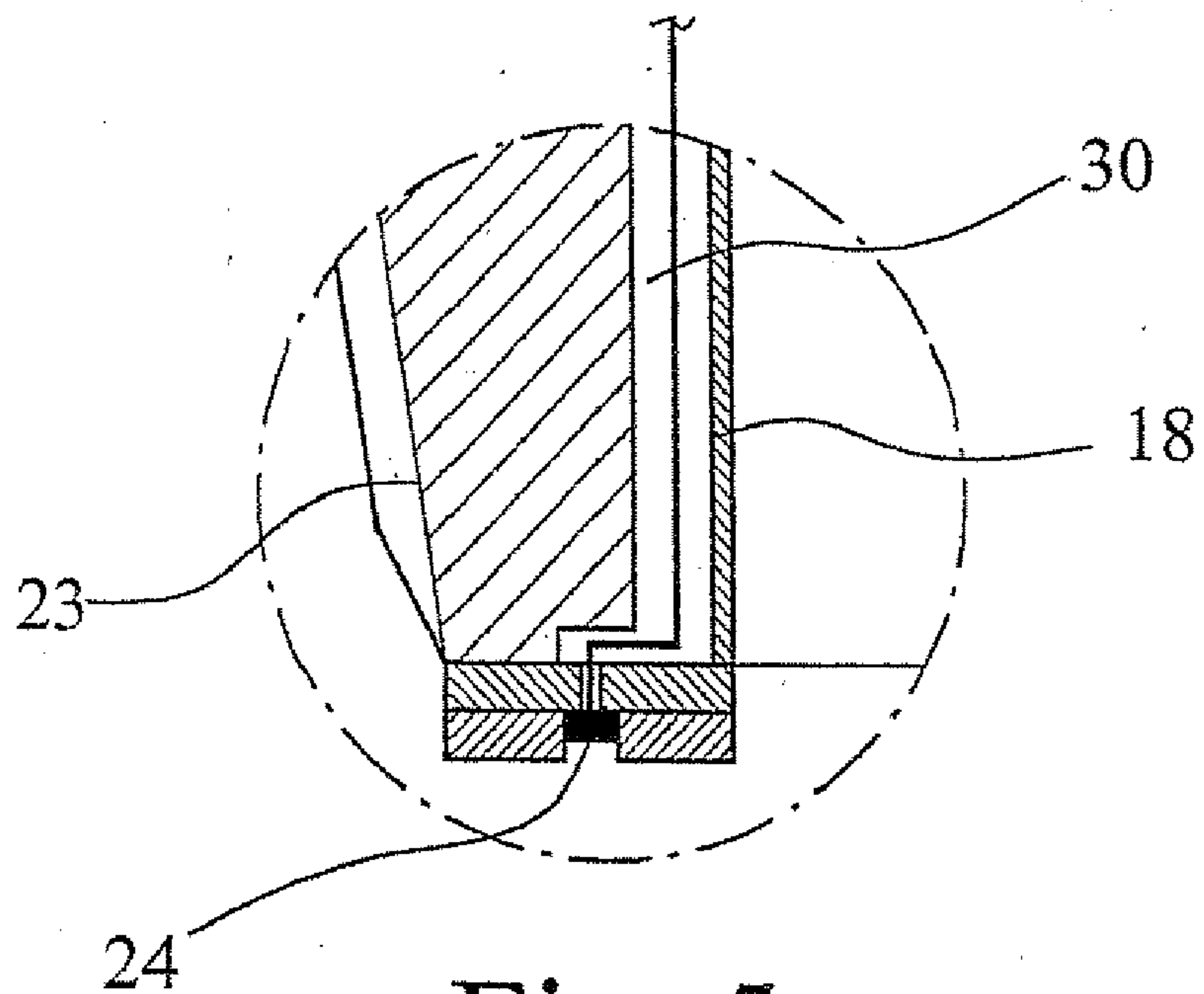

Fig. 5

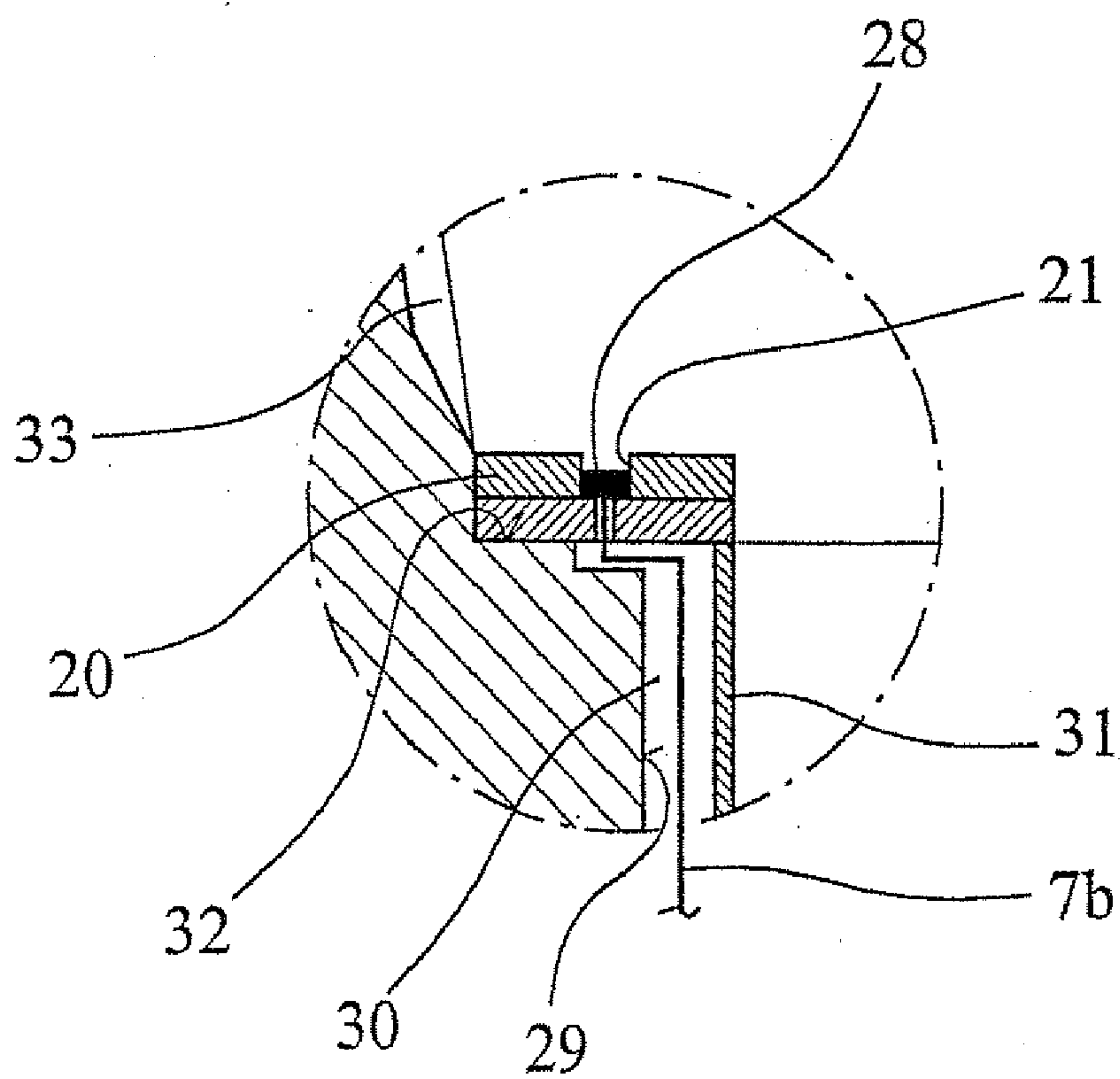

Fig. 6

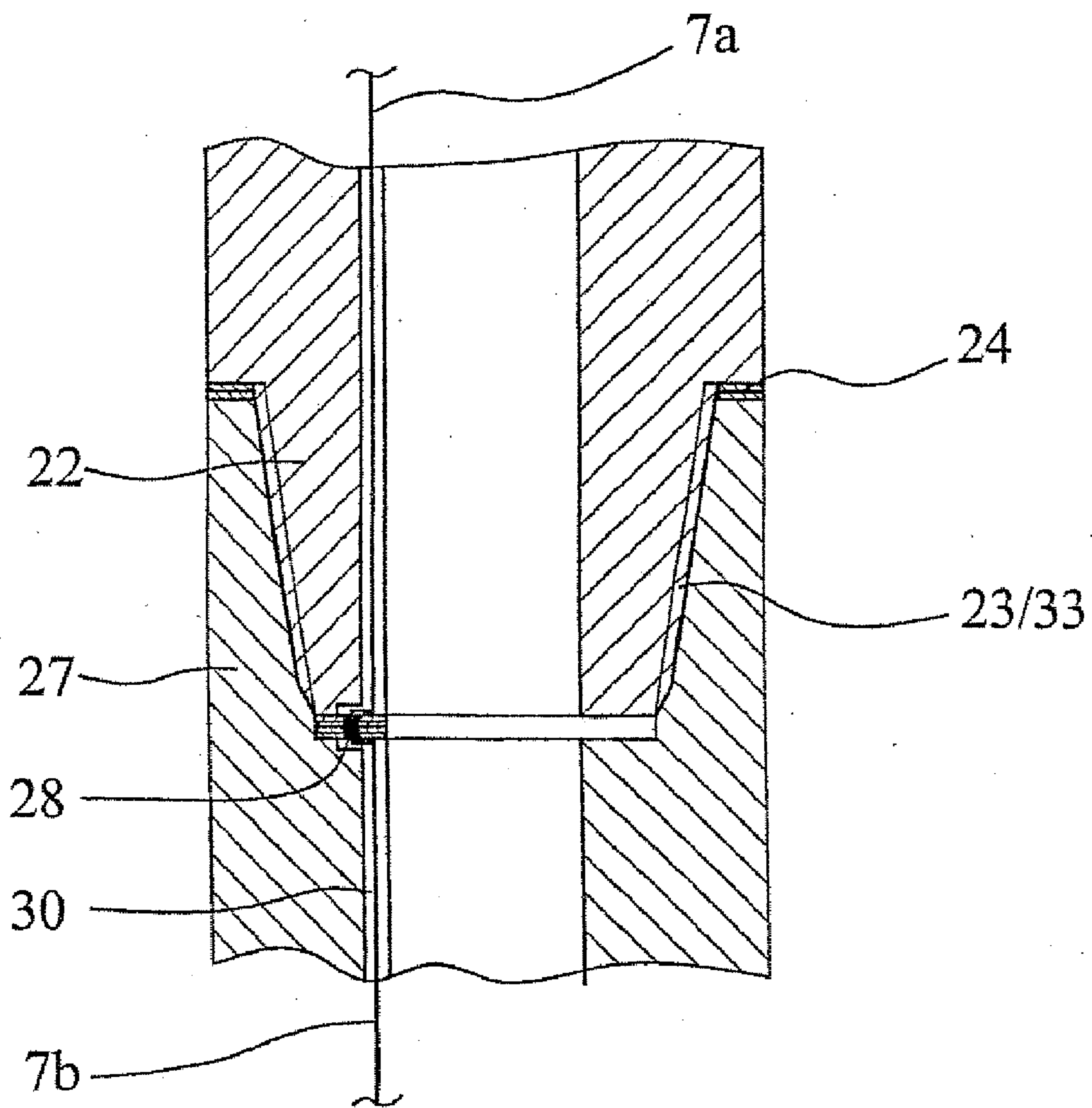

Fig. 7

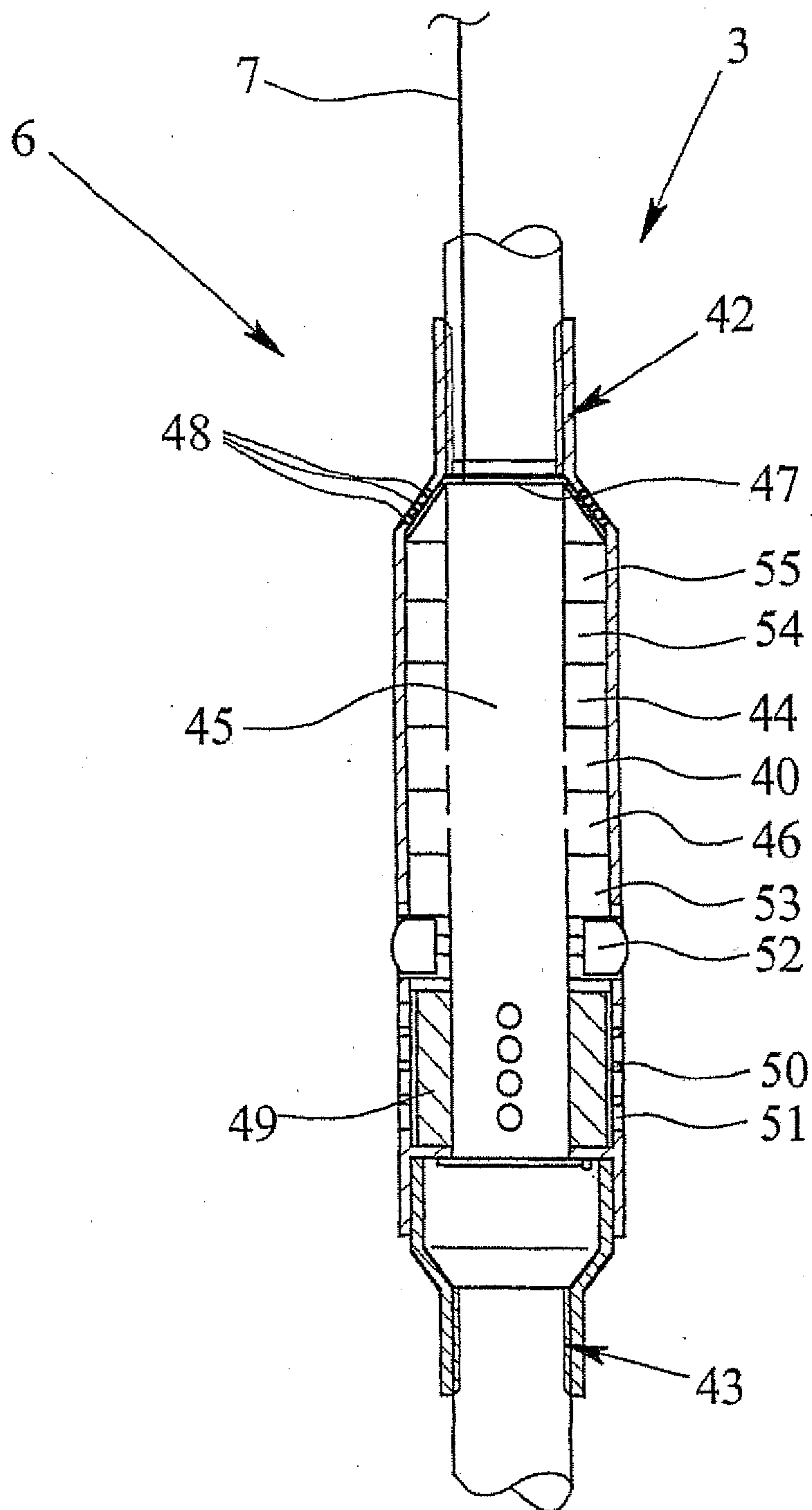

Fig. 8

MEASURING DEVICE AND DRILLING DEVICE FOR DEEP DRILLINGS

[0001] The present invention relates to a measuring device according to the precharacterizing clause of claim 1 and a drilling apparatus according to claim 16.

[0002] EP 0 102 672 B1 has disclosed a measuring device for connection to a drill column for deep wells, having an electrically operated measuring unit for measuring relevant data, the measuring device being designed for supplying electrical energy via the drill column. The measuring device converts soil properties into electrical signals and is driven into the soil for soil investigations. Owing to the arrangement of the measuring device provided at the end of the drill column, with the known measuring device only measured data can be recorded which relate to the soil region surrounding the measuring head at the end of the drill column. It is not possible with the known measuring device to record measured data above the bottom of the borehole.

[0003] One object of the present invention is to develop a measuring device according to the precharacterizing clause of Claim 1.

[0004] The abovementioned object is achieved by the characterizing features of claim 1.

[0005] In principle, the measuring device can be provided at any desired point in the drill string. The measuring device can be arranged directly adjacent to the bit unit, with the result that measured values can be taken from the bottom of the borehole. The arrangement of a plurality of measuring devices in one drill string is also easily possible. In order to measure relevant data, the measuring device is supplied with electrical energy via the drill column. In the same manner, the data transfer or signal transfer takes place from the measuring device to the surface. In this case, an evaluation device is provided at the surface, the measuring device being electrically coupled to the evaluation device. In this case, the electrical coupling is used firstly for the data transfer or signal transfer from the measuring device to the surface and can secondly also be used for the transfer of control commands.

[0006] The measuring device has a stable outer housing for accommodating and thus protecting the individual functional units. In order for it to be possible for it to be integrated in the drill column or the drill string or to be connected to parts of the drill string, the housing has screw connections at both of its ends. The screw connections should preferably have an internal thread such that the housing corresponds to a bush from a connection point of view.

[0007] The functional units of the measuring device may have an associated transformer, in particular a voltage transformer, which converts the measured signals recorded by the measuring unit such that the converted signals, which may have a different frequency from the electrical energy supplied, are correctly identified by the evaluation device. Moreover, the evaluation device may also be designed such that the measured signals are derived from the energy consumption of the measuring unit.

[0008] Depending on the application, the measuring unit can have a plurality of measuring instruments for the purpose of recording various data. In this case, in principle all

of the known measurement and/or analysis methods can be used, in which case it goes without saying that a correspondingly robust design is provided in terms of the conditions in the borehole. Moreover, the individual measuring instruments may be of modular design, with the result that, if necessary, one type of measuring instrument can be replaced by another type of measuring instrument if the measuring device is used for a different application.

[0009] In principle it is possible for the sensors of the measuring unit to be provided on the outside on the housing, with the result that the measured values are taken from the medium which flows past the housing on the outside. In order to protect the measuring unit and in particular the sensors or measured value pickups, however, a possible solution is to provide the sensors in a flow path within the housing. In order to guide the medium under investigation past the sensors of the measuring unit, at least one electrically operated pump is provided which is connected in terms of flow to the measuring unit. In this context, it is favourable then to provide an electrically operated two-way valve adjacent to the measuring unit in order to divert the medium under investigation, if necessary, either into the annular space or else into the drill column.

[0010] In connection with the above-described pump, a possible solution is to provide at least one filter and/or valves. A filter connected upstream makes it possible to largely prevent the pump and/or the sensors from being adversely affected. Owing to upstream valves, the flow path to the pump can be sealed, which is important if, for certain reasons, no measurement is intended to be carried out and no medium is intended to reach the measuring device.

[0011] While the invention makes it possible to take measured values during drilling, in principle it is also possible to interrupt the drilling operation for a short period of time and to take samples of the medium in the region of the bottom of the borehole. For this purpose, the measuring device has an electrically, in particular electrohydraulically, operated packer. The packer is provided for the purpose of dividing the annular space into a section above the packer and a section beneath the packer. In this case, the two sections are virtually sealed off. In the inserted state, the packer does not protrude beyond the housing or only protrudes beyond the housing to an insignificant extent. In the withdrawn state, the packer bears against the wall of the borehole. In order to achieve a virtually sealing function, the packer has a plurality of packer segments, which at least partially overlap one another at least in the inserted state.

[0012] In order to take a sample once the packer has been withdrawn, it is necessary to interrupt the circulation of the borehole mud. Owing to the fact that the mud is at a standstill, floating particles, which are constituents of the mud, may sink and become deposited on the upper side of the packer. This can lead to difficulties when reinserting the packer. In order to eliminate this problem, an in particular electrically operated lubricant supply device is provided above the packer, by means of which a layer of lubricant is applied to the upper side of the packer segments in the withdrawn state of the packer segments or when the packer segments are being withdrawn. The layer of lubricant in this case acts firstly as a protective layer and secondly as a sliding layer, which favours reinsertion of the packer into the housing.

[0013] If, in the withdrawn state of the packer, the borehole mud sinks in the upper part, considerable loading of the packer may result. For this reason, the invention provides for the pump to be designed to lower the level of the annular space beneath the packer in the withdrawn state of the packer. In this context, the inflow opening of the housing into the measuring device is in this case provided beneath the packer, while the outflow opening in the housing is located above the packer.

[0014] Owing to the various drive possibilities, a possible solution is to provide an electrically operated control unit for the purpose of driving the functional units, as necessary. The control unit, if necessary, is driven at the surface via the evaluation device, in which the measured values are displayed, evaluated and processed.

[0015] A generator which is provided at the surface is generally used for supplying energy to the measuring device. In order to ensure operation of the measuring device even in the event of operational faults of the generator, the measuring device has an energy store for an emergency power supply. Finally, this energy store is a rechargeable battery provided in the housing.

[0016] Exemplary embodiments of the invention will be described below with reference to the drawing, in which:

[0017] FIG. 1 shows a schematic view of a drill column introduced into a borehole,

[0018] FIG. 2 shows a schematic view of the pipe end of a drilling pipe,

[0019] FIG. 3 shows a schematic view of part of a bush,

[0020] FIG. 4 shows a cross-sectional view of part of a drilling pipe,

[0021] FIG. 5 shows a detailed view of part of a drilling pipe,

[0022] FIG. 6 shows a detailed view of a bush,

[0023] FIG. 7 shows a schematic partial view of a drilling pipe which has been screwed into a bush, and

[0024] FIG. 8 shows a schematic view of a measuring device according to the invention.

[0025] FIG. 1 shows a schematic illustration of a drilling apparatus 1. The drilling apparatus 1 has a drilling head 2 which is arranged at the surface and a drill column 3, which is located in a borehole 4 in the drilling state. A bit unit 5 is located at the lower end of the drill column 3. In the exemplary embodiment illustrated, a measuring device 6, which is connected to an evaluation device 8, which is located at the surface, via a conductor 7, is located directly above the bit unit 5. The measuring device 6 makes it possible to record measured values during drilling which can then be evaluated directly via the evaluation device 8.

[0026] The drill column 3 itself in this case comprises a large number of alternately arranged drilling pipes 10 and bushes 11. Drilling pipes 10 of the type in question may have a length of up to 10 m or longer, while the drilling column 3 for deep wells may have a length of several thousand metres.

[0027] FIG. 2 and the detailed illustration shown in FIG. 4 illustrate part of a drilling pipe 10. The drilling pipe 10 has

a drilling pipe body 12 made from an electrically conductive material. Provision is now made for at least one electrical pipe conductor 7a to be passed through the drilling pipe body 12, said electrical pipe conductor 7a being connected at the end, to be precise at both ends, to a pipe contact connection 13 provided on the drilling pipe body 12, the pipe conductor 7a and the pipe contact connection 13 being electrically insulated from the drilling pipe body 12. As in shown in particular in FIG. 4, the pipe conductor 7a is fixed to the pipe inner side 14. For this purpose, a longitudinal groove 15 for the pipe conductor 7a is provided on the pipe inner side 14. In this case, the groove 15 is dovetailed. In principle, however, any other groove shape is also possible. The groove 15 runs parallel to the centre axis of the drilling pipe 10. The depth of the groove 15 is in this case greater than the outer diameter of the pipe conductor 7a. The pipe conductor 7a is held in the groove 15 by means of an insulation 16. In addition to its fixing function, the insulation 16 also has an electrically insulating function. In addition to the insulation 16, the pipe conductor 7a has a conductor insulation 17, which extends over the entire length of the pipe conductor 7a. As can further be seen in FIG. 4, an electrical insulating layer 18 is vapour-deposited over the entire surface of the pipe inner side 14 and also covers the groove 15 and thus the pipe conductor 7a. The insulating layer 18 is applied over the entire surface of the pipe inner side 14.

[0028] The pipe contact connection 13 is provided on the end-side front face 19 of the pipe end of the drilling pipe 10. In this case, it goes without saying that in each case a corresponding pipe contact connection 13 is provided at both ends of the drilling pipe body 12, even if this is not described in any more detail below. The pipe contact connection 13 is of circumferential design and has the form of a contact ring. Moreover, the pipe contact connection 13 is arranged on an insulating ring 20 resting on the front face 19. The insulating ring 20, which is made from an elastic material, has an annular groove 21 for the purpose of accommodating the pipe contact connection 13. In this case, the annular groove 21 is deeper than the height of the pipe contact connection 13.

[0029] Moreover, the pipe contact connection 13 is in this case spring-loaded in the direction away from the front face 19, namely in the direction towards the bush 11 to be connected to the drilling pipe 10.

[0030] A pin 22, on which an external thread 23 is provided, is located at the two pipe ends of the drilling pipe 10. A step 24, which merges at its end with the pipe outer side 25, is located between the pins 22 having the external thread 23. A circumferential seal 26, which in this case is an O ring, is located at the transition between the step 24 and the external thread 23. Instead of the seal 26, or in addition to said seal, a ring seal can also be arranged on the step 24.

[0031] FIG. 4 and the detailed illustration shown in FIG. 6 show part of a bush 11. The bush 11 has a bush body 27 made from an electrically conductive material. An electrical bush conductor 7b is passed through the bush body 27 and is connected at the end, to be precise at both ends of the bush body 27, to bush contact connections 28, even if this is not specifically illustrated. The bush conductor 7b and the bush contact connections 28 are electrically insulated from the bush body 27.

[0032] The bush conductor **7b** is fixed to the bush inner side **29**. For this purpose, a longitudinal groove **30** is provided on the bush inner side **29** of the bush body **27**. The groove **30** has the same design as the groove **15**. Moreover, the groove **30** runs parallel to the centre axis of the bush **11**. The illustration does not show the fact that the bush conductor **7b** is cast into the groove **30** via an insulation and is moreover sheathed by a conductor insulation. Furthermore, an electrical insulating layer **31** is vapour-deposited onto the bush inner side **29**, as is also the case for the pipe inner side **14**, said insulating layer **31** also covering the bush conductor **7b**.

[0033] As can be seen in particular in FIG. 6, the bush contact connection **28** is provided on a front-side shoulder **32**. The shoulder **32** is located between the internal thread **33** and the bush inner side **29**. The bush contact connection **28** is of circumferential design and is arranged on an insulating ring **20** resting on the shoulder **32**. The insulating ring **20** corresponds in terms of type and design to the insulating ring **20** provided on the drilling pipe **10**, i.e. has an annular groove **21** for the purpose of accommodating the bush contact connection **28**, the annular groove **21** being deeper than the height of the bush contact connection **28**. Moreover, the bush contact connection **28** is spring-loaded in the direction away from the shoulder **32**. The spring-loading may be designed as regards the contact connections **13**, **28** such that one or more springs, for example small helical compression springs, act on the respective underside of the contact connection. Furthermore, spring tongues may be provided on the respective contact connection. The spring tongues can in principle point inwards and/or outwards, in which case outwardly pointing spring tongues can then protrude beyond the actual contact connection and cause the electrical contact to be made.

[0034] In this case, a circumferential seal **35** is located on the outer front face **34** of the bush body **27**. The outer front face **34** is located between the internal thread **33** and the bush outer side **36**.

[0035] The drilling pipes **10** and bushes **11**, as described above, in conjunction with the pipe conductors **7a** and bush conductors **7b** result in a two-pole energy and data transmission system via the drill column **3**. In this case, one pole is formed by the drill column body, which comprises the drilling pipe bodies **12** and the bush bodies **27**, while the other pole is formed by the conductor **7**, which comprises the pipe conductors **7a** and the bush conductors **7b** as well as the contact connections **13** and **28**. The system according to the invention moreover provides the advantage that the drill column **3** and thus the two poles can be extended as desired since, owing to a drilling pipe **10** being screwed to a bush **11**, the electrical connection is formed via the contact connections **13**, **28** on the one hand and via the material of the drilling pipe body **12** and the bush body **27** on the other hand.

[0036] Energy is supplied to the conductor **7** and data tapped off from it via a slipring collector (not illustrated), which is provided on the first drilling pipe **10**. The slipring collector is connected to the pipe conductor **7a** and insulated from the drilling pipe body **12**. The slipring collector is in turn connected to the evaluation device **8**, while the drill column body forms the connection to earth.

[0037] FIG. 8 shows a schematic illustration of the measuring device **6**. In this case, the measuring device **6** is

connected to the last drilling pipe **10** of the drill column **3**. In this case, the measuring device **6** has an electrically operated measuring unit **40**, with which it is possible to measure relevant data on the state of the rock, the drilling mud or the raw material to be obtained. The measuring device **6** is in this case supplied with electrical energy via the above-described conductor **7**. In this case, it goes without saying that the measuring device **6** has a contact connection corresponding to the contact connections **13**, **28** and an extension of the conductor **7**, even if this is not specifically illustrated.

[0038] The measuring device **6** has an outer housing **41**, in which the measuring unit **40** and further functional units are accommodated, which functional units will be explained in more detail below. The housing **41** has in each case screw connections **42**, **43** at its two ends for connection to the drill string and the bit unit **5**. The screw connections **42**, **43** correspond to those of the bush **11**. However, reference will be made to the fact that, in principle, it is also possible for other screw connections to be provided, in particular even those having an external thread. Finally, it is merely critical that the measuring device **6** can be integrated in the drill column **3**.

[0039] The measuring device **6** has a transformer **44** for the purpose of converting measured signals recorded via the measuring unit **40** for subsequent transfer to the evaluation device **8**. The illustration does not show the fact that the measuring unit **40** may have a plurality of different measuring instruments for recording a wide variety of data relating to the relevant medium. The individual measuring instruments should be of modular design, with the result that, if necessary, it is possible to replace measuring instruments. In the exemplary embodiment illustrated, the sensors or the measured value pickups are provided in the flow path **45** within the housing **41**. In principle, however, it is also possible for the measured value pickups to be directed outwards into the annular space via outer openings in the housing **41**.

[0040] Furthermore, an electrically operated pump **46** is provided which supplies the medium under investigation to the measuring unit **40** via the flow path **45**. An electrically operated valve unit **47** having at least one two-way valve is provided above the measuring unit **40** in order to divert the medium under investigation, if necessary, into the annular space or else via the drill column **3**. For this purpose, corresponding outflow openings **48** are provided in the housing **41**. In this case, at least one filter **49** and a valve unit **50** are connected upstream of the pump **46**. The valve unit **50** is used for sealing inflow openings **51** provided in the housing **41**.

[0041] Furthermore, an electrohydraulic packer **52** is provided. The packer **52** has a plurality of packer segments, which are not illustrated in any more detail. In the inserted state of the packer **52**, which is illustrated in FIG. 8, the packer segments at least partially overlap one another. The packer **52** is overall designed such that, in the withdrawn state, it divides the annular space into an upper and a lower part and in the process at least substantially seals off these sections. Directly above the packer **52** is a lubricant supply device **53**, which is used for applying a layer of lubricant to the upper side of the packer segments in the withdrawn state. The lubricant supply device **53** can be operated electrically

or else mechanically. The mechanically operated lubricant supply is preferably mechanically coupled to the packer 52 if the lubricant supply is actuated when the packer segments are being withdrawn.

[0042] Furthermore, the measuring device 6 in this case has a control unit 54 for driving the individual functional units and an energy store 55, as necessary.

[0043] Moreover, it goes without saying that the above-mentioned functional units do not necessarily need to be arranged in the sequence illustrated. As long as the operation of the measuring device 6 is not called into question, other arrangements can also be selected. However, it is necessary to take care that the packer 52 is located between the lower inflow openings 51 and the upper outflow openings 48 in order to make it possible to lower the level of the annular space beneath the withdrawn packer 52 via the pump 46.

[0044] Moreover, a string section, which forms the flow path 45 and has a through-opening which communicates with the drill column 3 or the opening therein and the bit unit 5, is located in the housing 41. Moreover, the outflow openings 48- and the inflow openings 51 communicate with the string section forming the flow path 45. In this case, a nonreturn valve 56, which closes the through-opening, is located at the end of the string section. Said nonreturn valve 56 has an electric drive (not illustrated).

[0045] No detailed illustration is provided to show that the individual functional units of the measuring device 6 are electrically connected to the two above-described poles, which makes electrical energy supply and, as far as the measuring unit 40 or the control unit 54 are concerned, data exchange with the evaluation device 8 possible.

[0046] Instead of the above-described embodiment, in which the drill string is open in the housing 41 of the measuring device 6, it is in principle also possible for the measuring device 6 to have a passage pipe section, which is connected either at both ends or else at one end to the drill column and at the other end to the bit unit 5. The medium is then passed through corresponding flow paths through the housing and in the process also past the measuring unit 40 for analysis purposes. In this case too, provision may be made for the already measured medium to either be output to a drill string or else into the annular space. A corresponding valve unit which opens into the drill string is required in this case.

[0047] The invention makes it possible to measure the state of the medium in the borehole continuously prior to, during and after drilling. The data can be evaluated immediately in the evaluation device 8. Hydrological changes, for example, during drilling are thus identified without delay and sampling is also immediately possible. For this purpose, in the embodiment illustrated the nonreturn valve 56 closes off the drilling pipe at the bottom while the packer 52 is being withdrawn. The pump 46 then conveys the medium, once the outflow openings 48 have been closed by means of the valve unit 47, through the drill string to the surface.

1. Measuring device (6) for connection to a drill column (3) for deep wells, having an electrically operated measuring unit (40) for measuring relevant data relating to the rock, the drilling mud and/or the raw material to be obtained, the measuring device (6) being designed for supplying electrical energy via the drill column (3) and for data transfer to the

surface likewise via the drill column (3), characterized in that an outer housing (41) of the measuring device (6) having at least one inflow opening (51) and at least one outflow opening (48) is provided, and in that the housing (41) has screw connections at its two ends for connection to the drill column (3) and/or the bit device (5).

2. Measuring device according to claim 1, characterized in that the measuring device (6) has an associated evaluation device (8) arranged at the surface, and in that the measuring device (6) is electrically coupled to the evaluation device (8).

3. Measuring device according to claim 1, characterized in that a transformer (44), in particular a voltage transformer, is provided for the purpose of converting measured signals for subsequent transmission to the evaluation device (8) and/or in that the evaluation device (8) is designed such that the measured signals are derived from the energy consumption of the measuring unit (40).

4. Measuring device according to claim 1, characterized in that the measuring unit (40), if necessary, has a plurality of in particular modular measuring instruments for the purpose of recording various data.

5. Measuring device according to claim 1, characterized in that the measured value pickups of the measuring unit (40) are directed in a flow path (45) within the housing (41).

6. Measuring device according to claim 1, characterized in that at least one electrically operated pump (46), which is connected in terms of flow to the measuring unit (40), is provided in order to supply the medium under investigation to the measuring unit (40).

7. Measuring device according to claim 1, characterized in that an electrically operated valve unit is provided in order to divert the medium under investigation, if necessary, into the annular space or the drill column.

8. Measuring device according to claim 1, characterized in that at least one filter (49) and/or valves (50) are connected upstream of the pump (46).

9. Measuring device according to claim 1, characterized in that an electrically operated, in particular electrohydraulic packer (52) is provided.

10. Measuring device according to claim 1, characterized in that the packer (52) has a plurality of packer segments, which at least partially overlap one another at least in the inserted state.

11. Measuring device according to claim 1, characterized in that an in particular electrically operated lubricant supply device (53) is provided for the purpose of applying a layer of lubricant to the upper side of the packer in the withdrawn state of the packer or when the packer is being withdrawn.

12. Measuring device according to claim 1, characterized in that an electrically operated control unit (44) is provided for the purpose of driving the functional units, as necessary.

13. Measuring device according to claim 1, characterized in that an energy store (55) is provided in the housing (41).

14. Measuring device according to claim 1, characterized in that the inflow opening (51) of the housing (41) is provided beneath the packer (52) and the outflow opening (48) is provided above the packer (52).

15. Measuring device according to claim 1, characterized in that a string section, which communicates with the drill column (3) and has a through-opening, is provided in the housing (41), and in that, preferably, a nonreturn valve (56) closing the through-opening is associated with the string section.

16. Drilling apparatus (1) for deep wells, having a drill column (3), having at least one measuring device (6) according to claim 1 and having an evaluation device (8) which is arranged at the surface and is electrically coupled to the measuring device (6).

17. Drilling apparatus according to claim 16, characterized in that a bit unit (5) is provided, and in that the measuring device (6) is connected with its lower end to the bit unit (5).

* * * * *