



(19) **United States**

(12) **Patent Application Publication**
Temmyo et al.

(10) **Pub. No.: US 2007/0144190 A1**

(43) **Pub. Date: Jun. 28, 2007**

(54) **REFRIGERATOR**

(30) **Foreign Application Priority Data**

Dec. 24, 2003 (JP) 2003-427845

(75) Inventors: **Minoru Temmyo**, Osaka (JP);
Takahiro Yoshioka, Osaka (JP);
Hidetake Hayashi, Osaka (JP)

Publication Classification

(51) **Int. Cl.**
F25D 17/00 (2006.01)
F25D 17/04 (2006.01)
F25B 49/00 (2006.01)
(52) **U.S. Cl.** **62/180**; 62/228.4; 62/186

Correspondence Address:
**OBLON, SPIVAK, MCCLELLAND, MAIER &
NEUSTADT, P.C.**
1940 DUKE STREET
ALEXANDRIA, VA 22314 (US)

(57) **ABSTRACT**

A refrigerator in which a two-stage-compression mode power-variable refrigerant circuit having a freezer cooler and fresh-food cooler is controlled in accordance with information on temperature in the fresh-food compartment. Thus, each of the freezer and fresh-food compartment is properly controlled at a temperature for storing. The refrigerant circuit includes an inverter-driven power-variable compressor having a low-pressure compression element and a high-pressure compression element, a switching valve disposed downstream of a condenser receiving gas refrigerant discharged from the compressor and selecting and controlling channel and flow rate of the refrigerant, and a freezer cooler and a fresh-food cooler, each connected with the switching valve through a pressure reducer. A frequency of the compressor is decided by a temperature in the freezer compartment and its target temperature.

(73) Assignees: **KABUSHIKI KAISHA TOSHIBA**, Tokyo (JP); **Toshiba Consumer Marketing Corporation**, Tokyo (JP); **TOSHIBA HA PRODUCTS CO., LTD.**, Ibaraki-shi (JP)

(21) Appl. No.: **10/584,205**

(22) PCT Filed: **Nov. 30, 2004**

(86) PCT No.: **PCT/JP04/17761**

§ 371(c)(1),
(2), (4) Date: **Jun. 23, 2006**

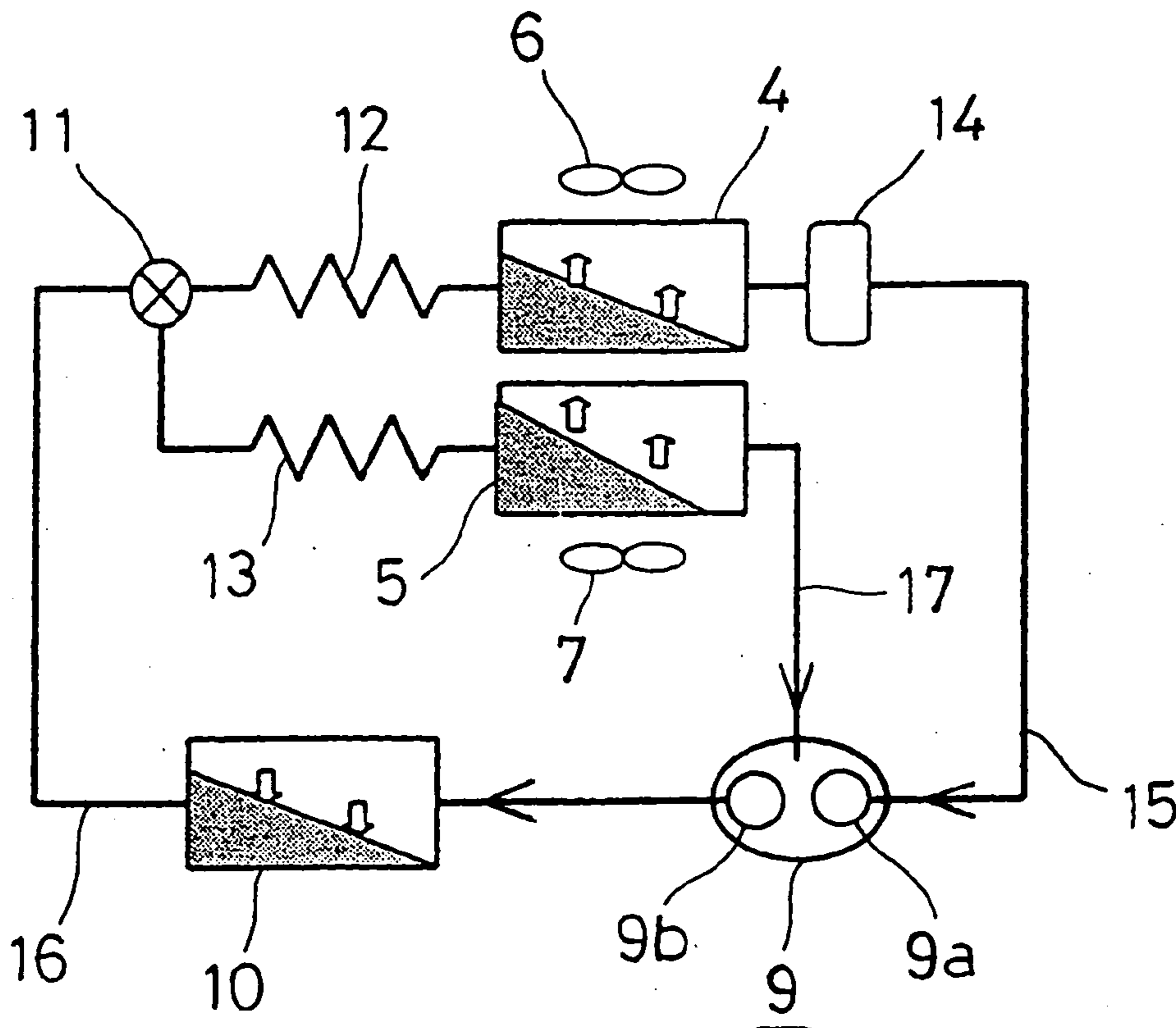

FIG. 1

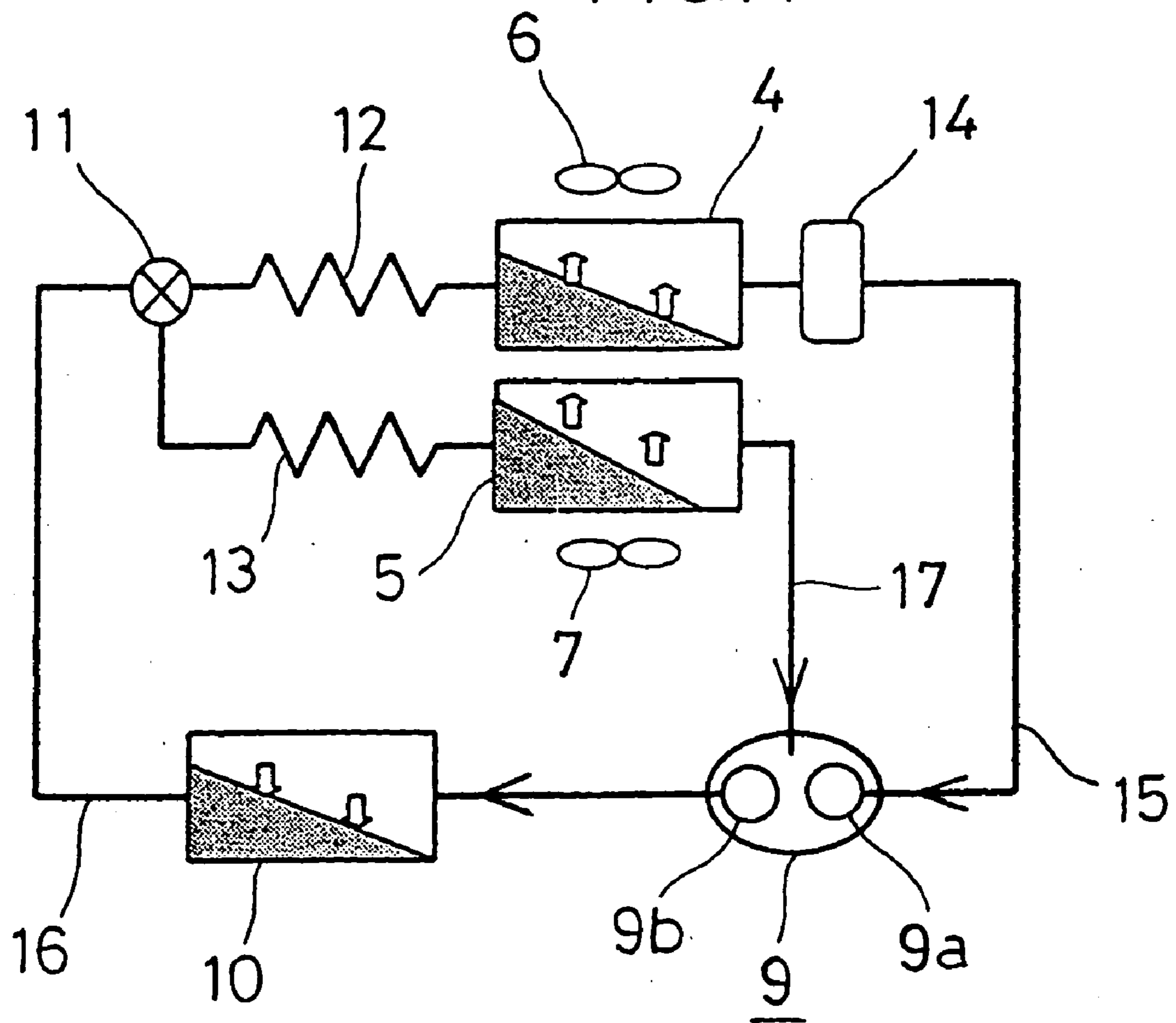

FIG. 2

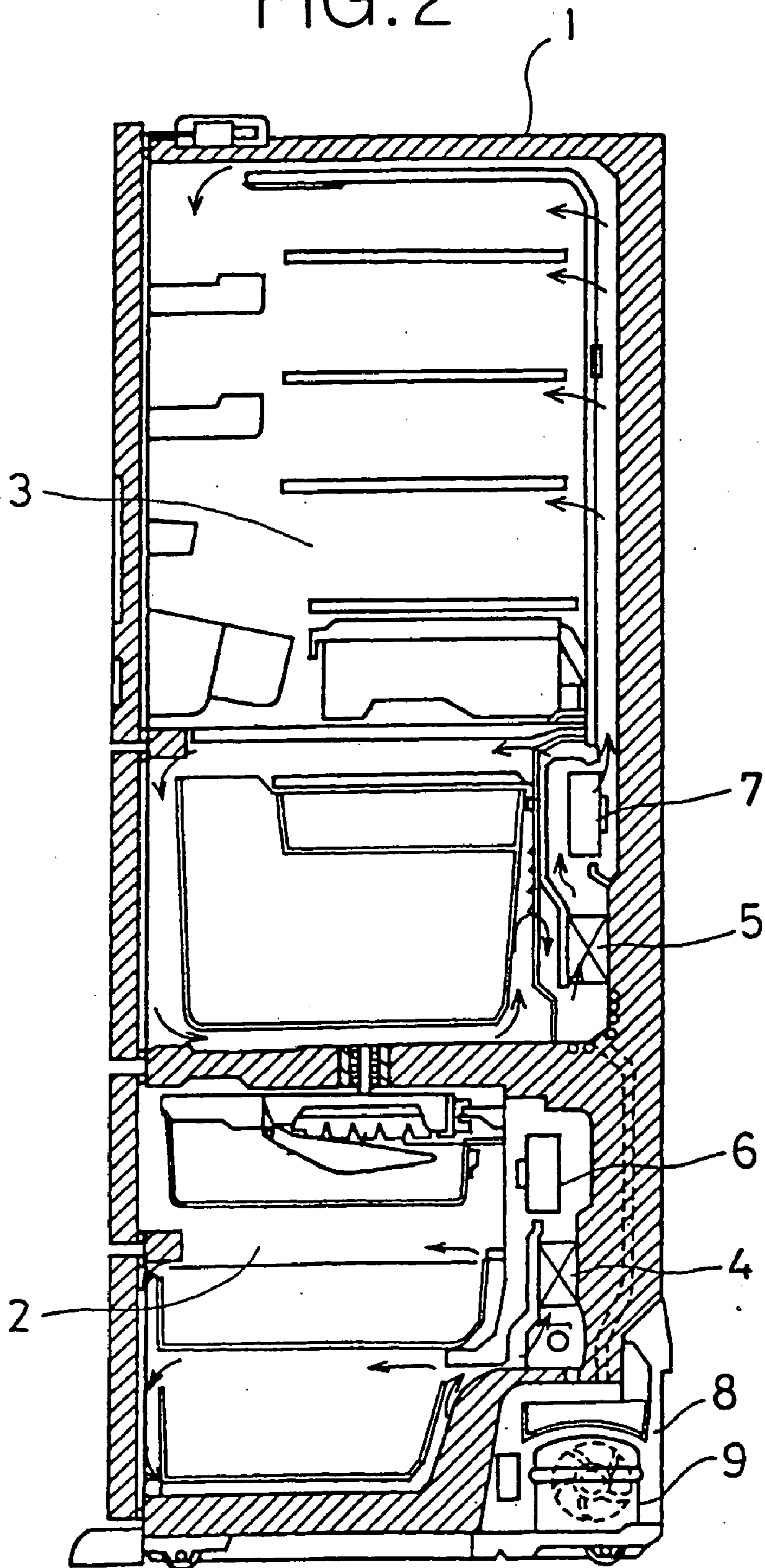

FIG. 3

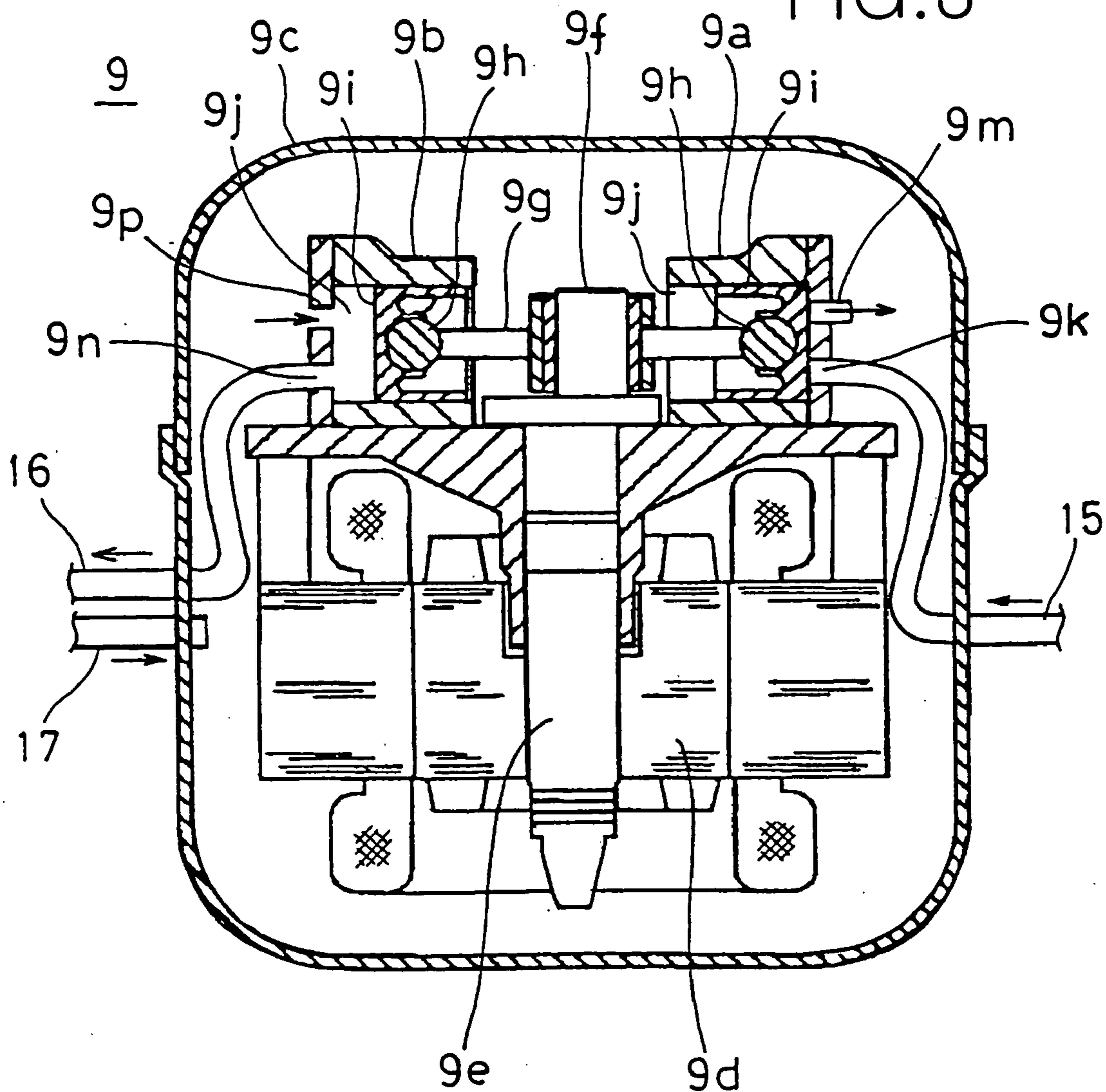

FIG. 4

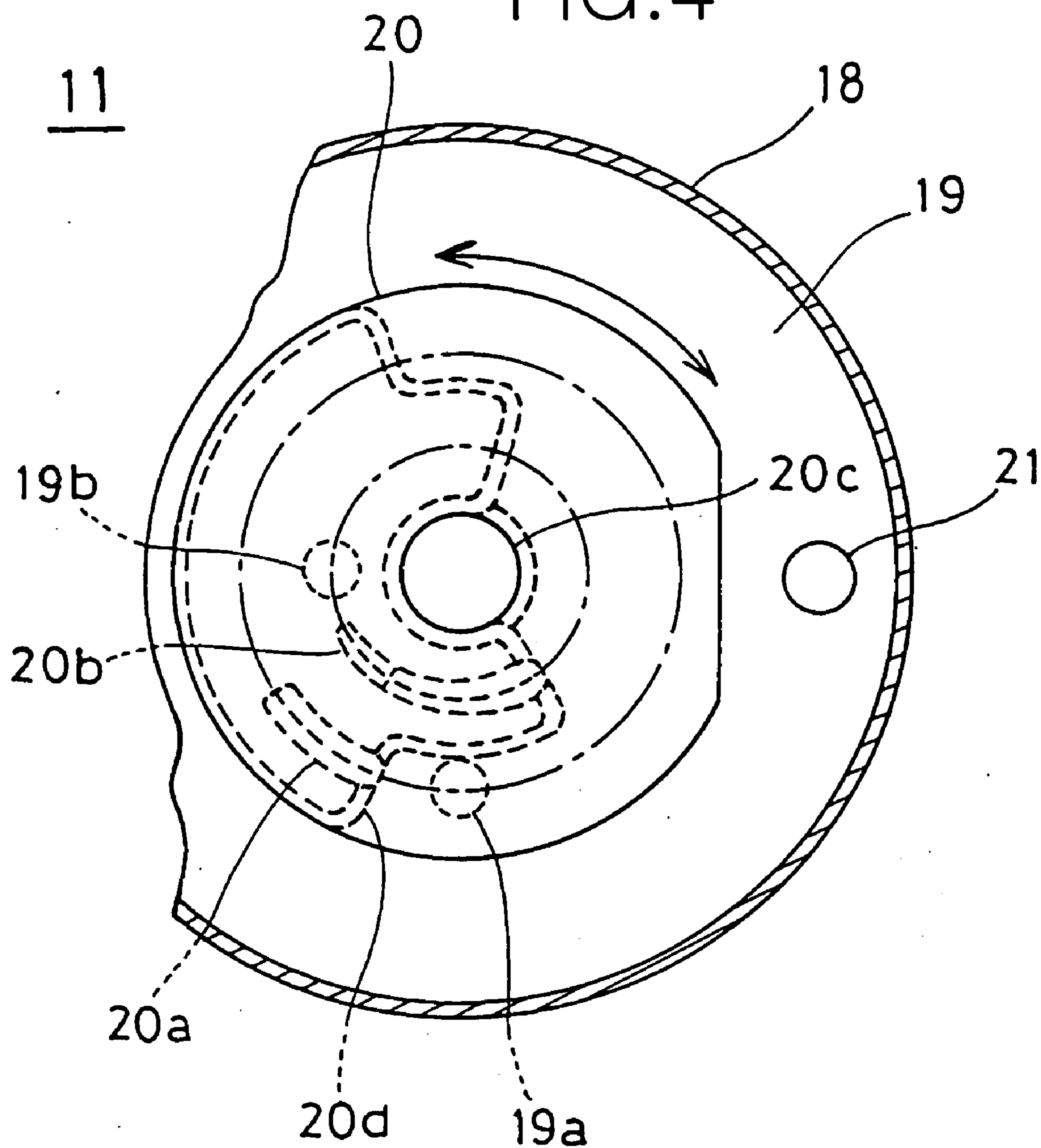

FIG.5

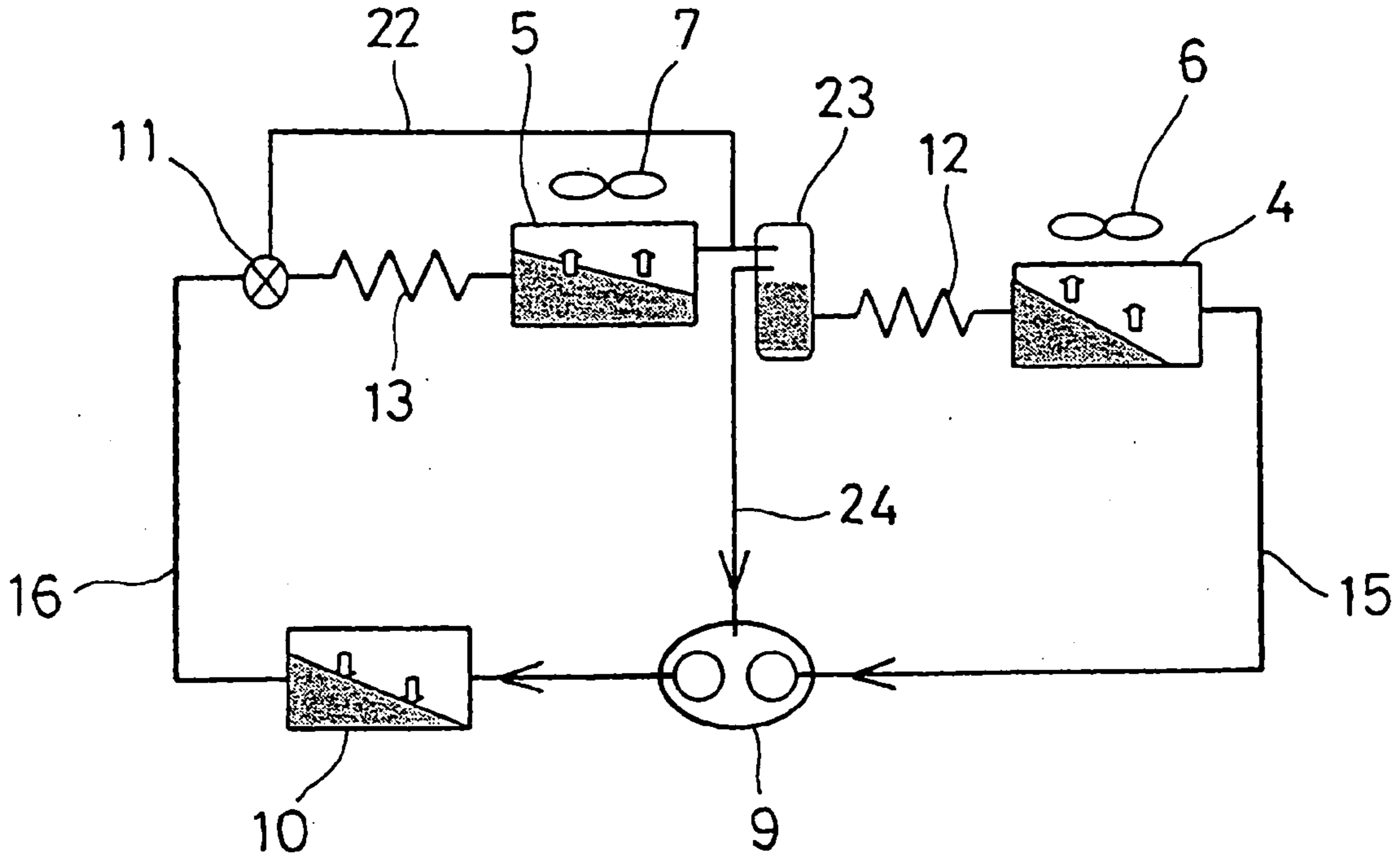
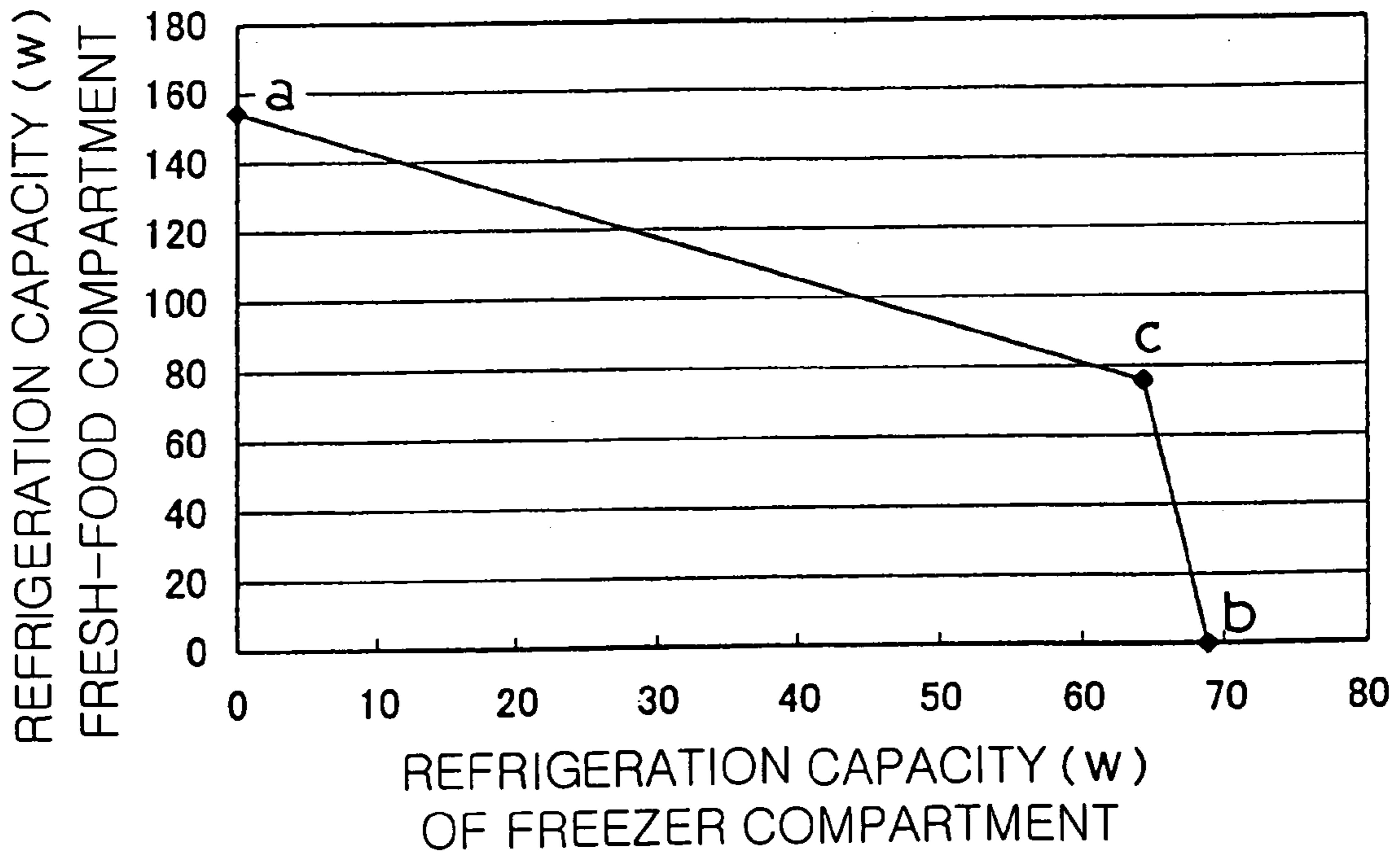
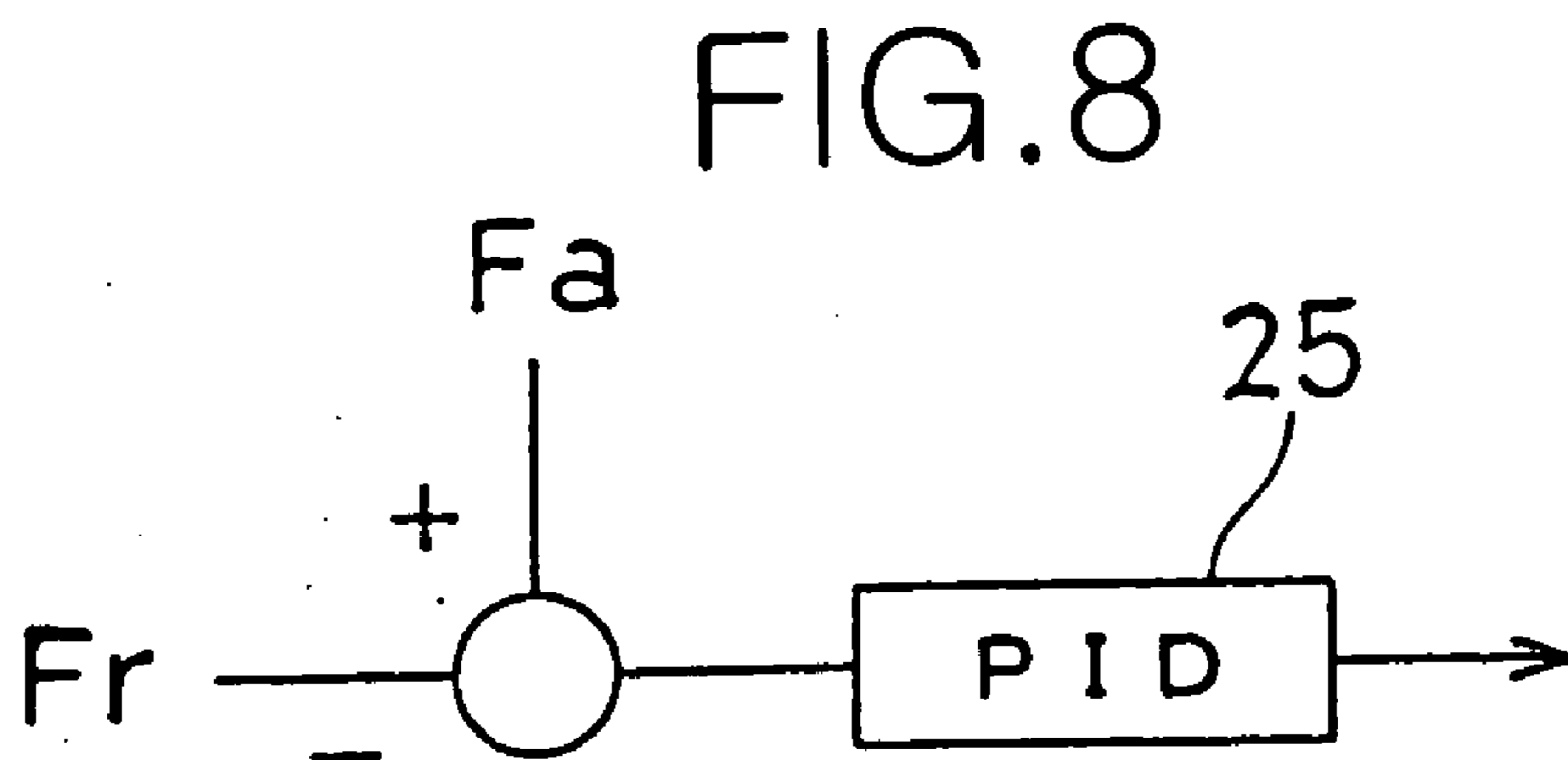
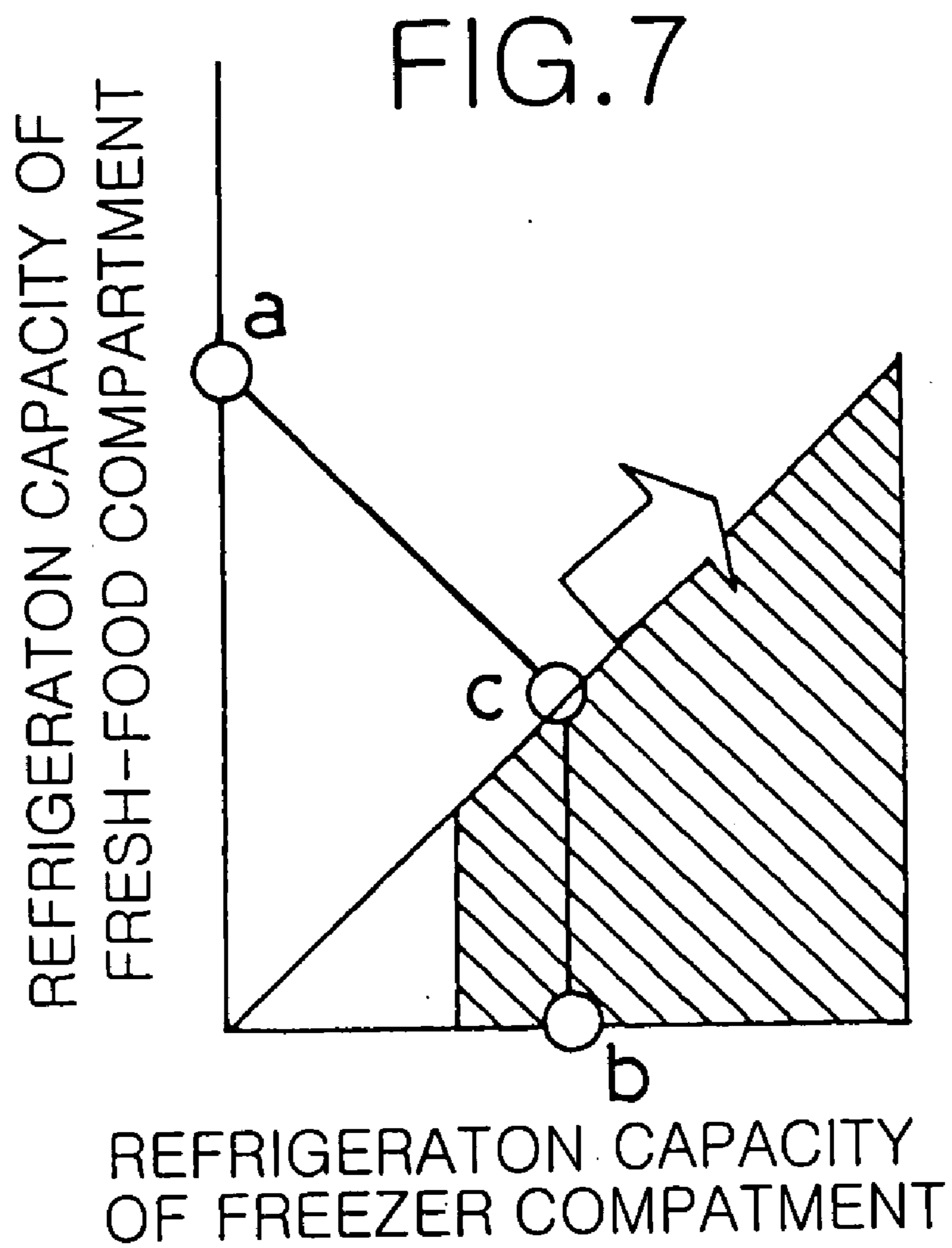

FIG.6





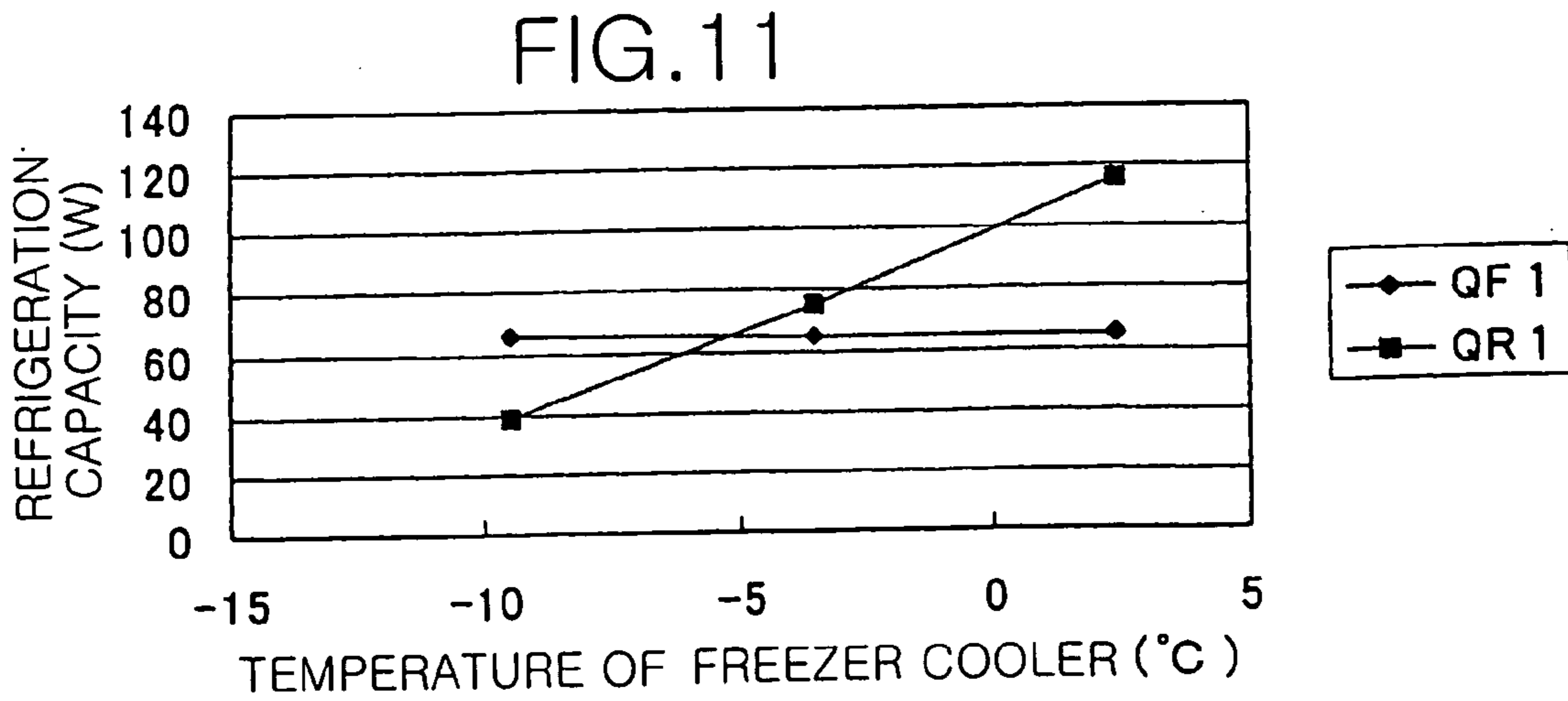
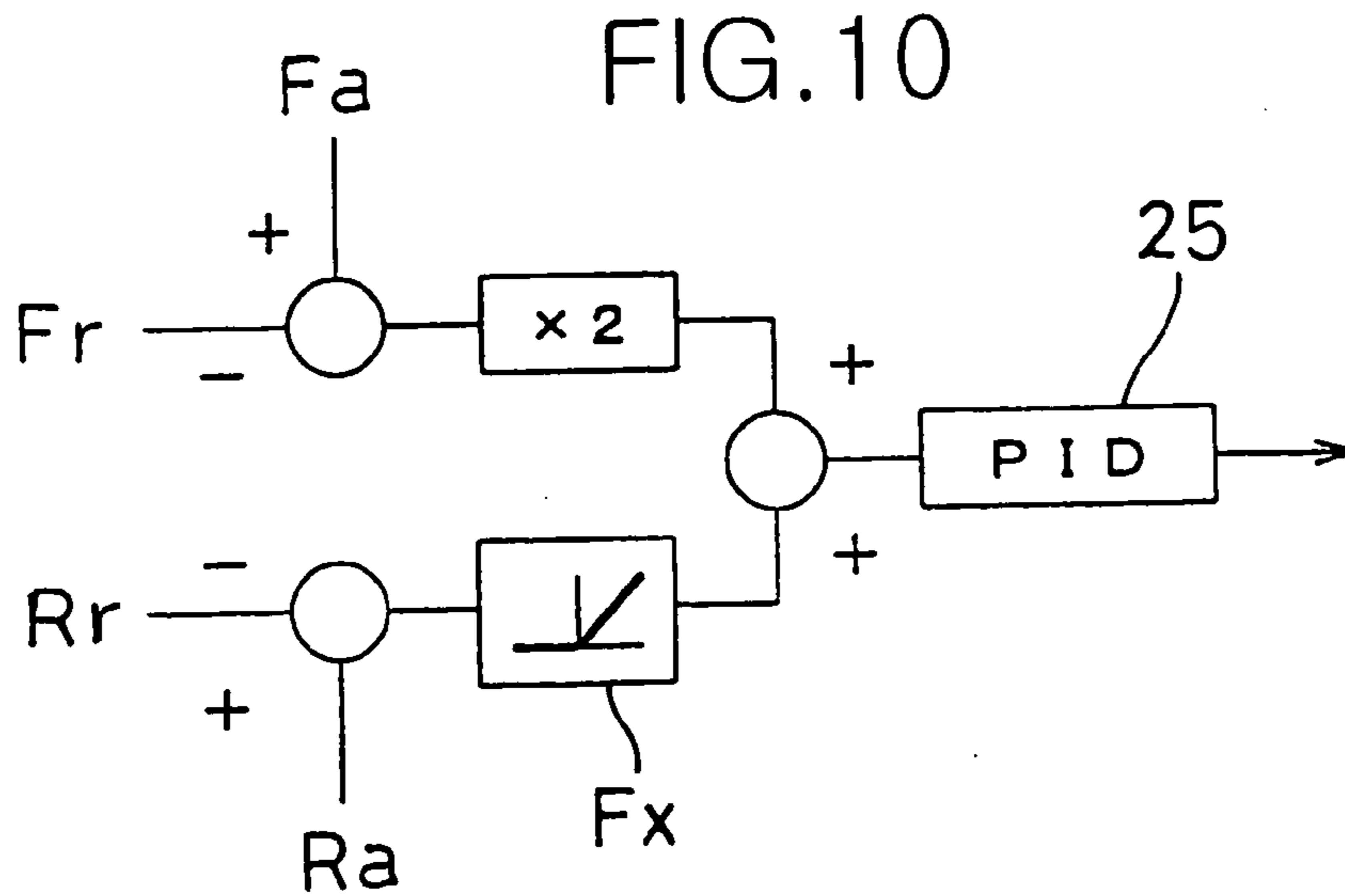
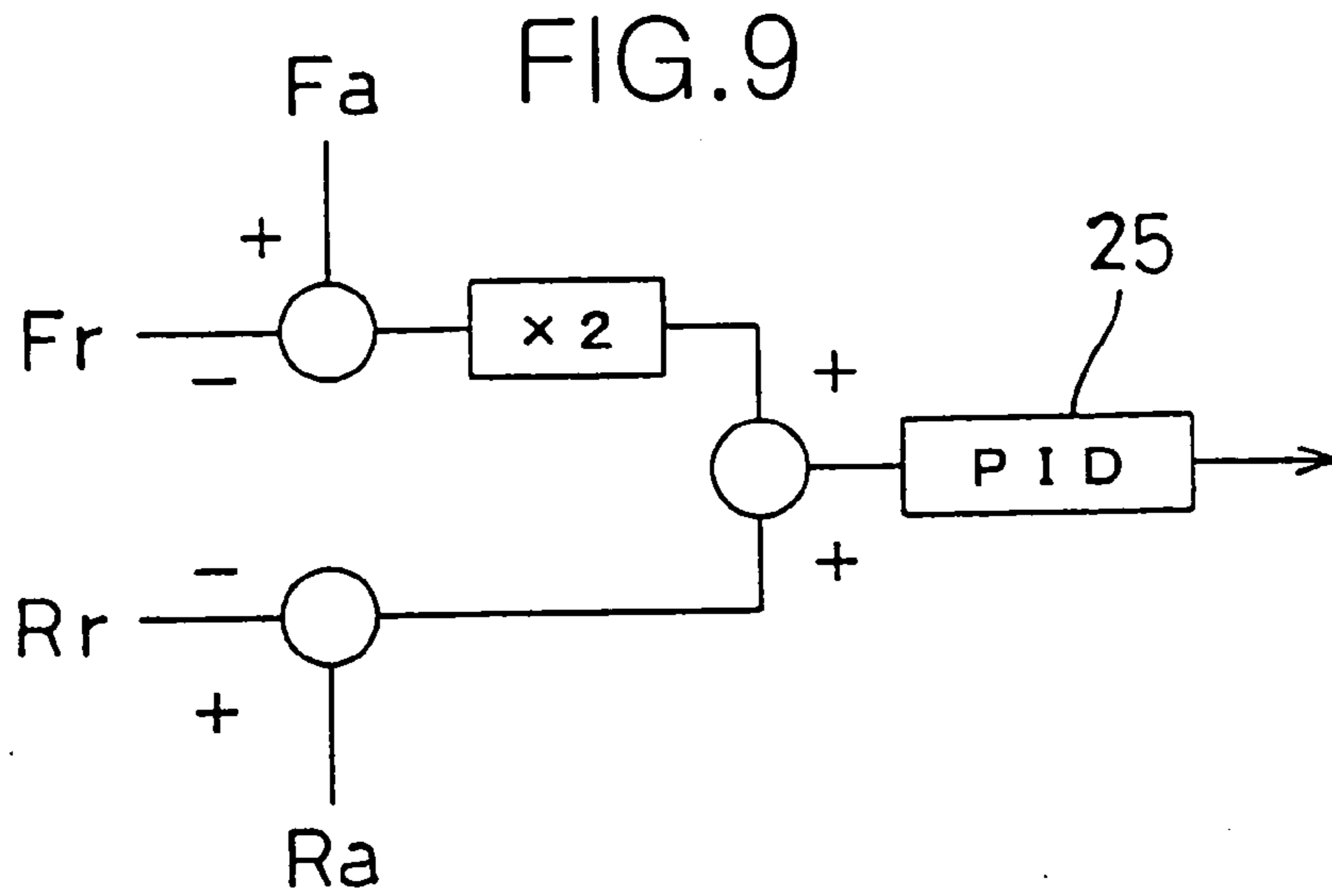

FIG.12

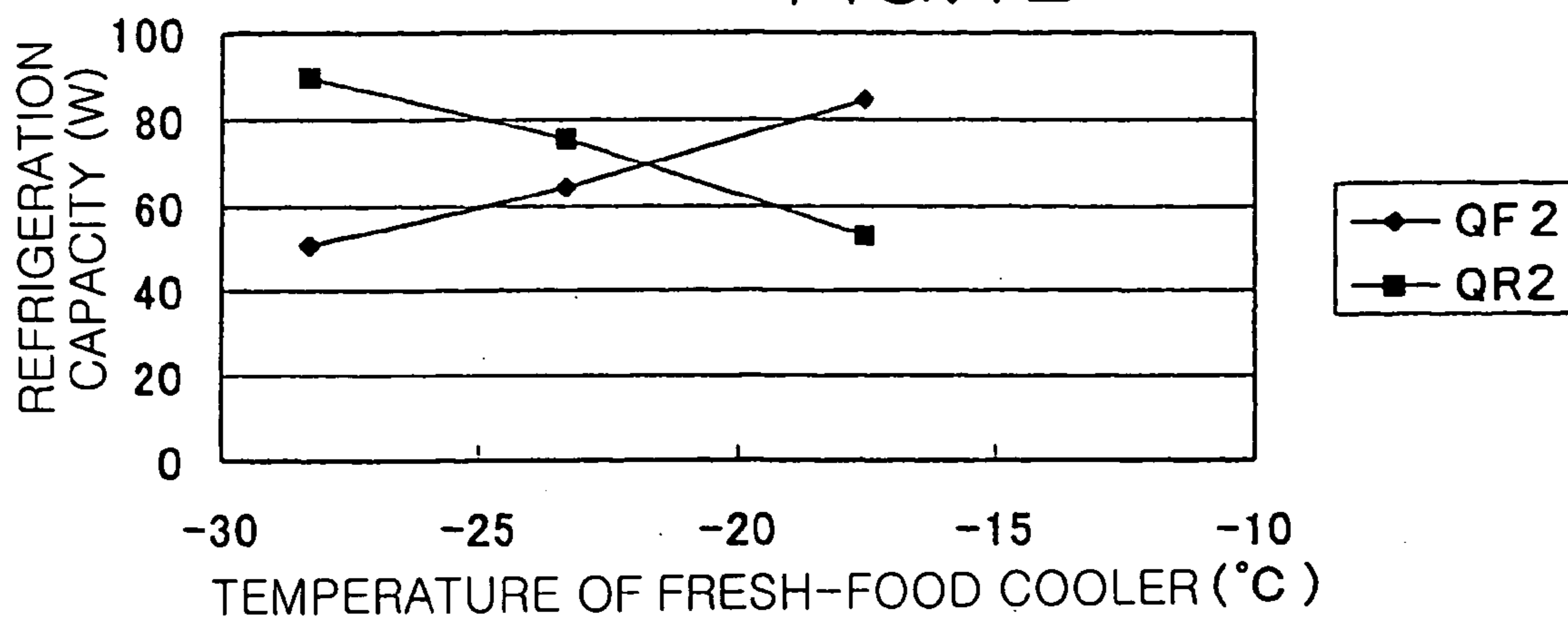
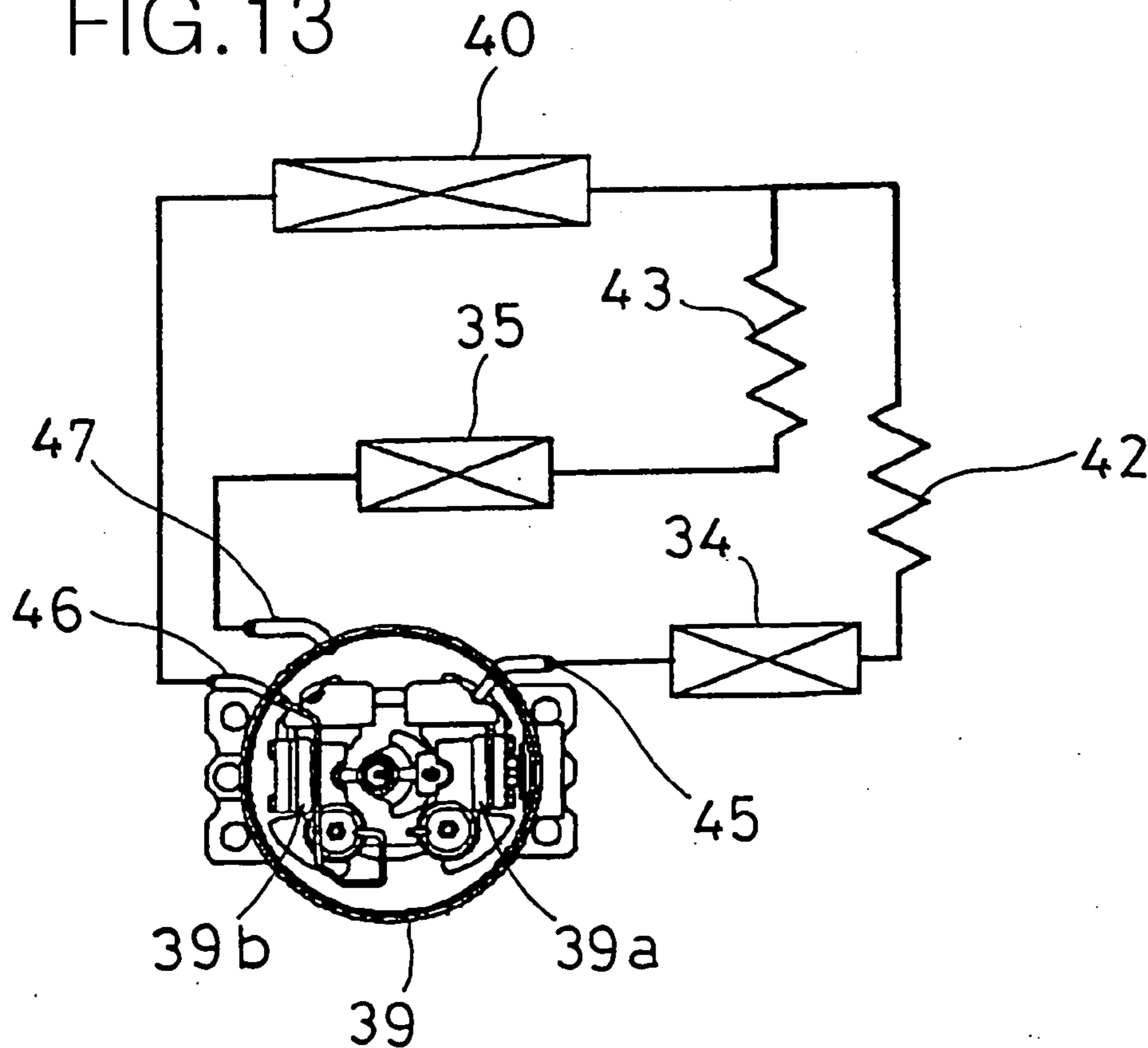

FIG.13



REFRIGERATOR

FIELD OF THE INVENTION

[0001] The invention relates to a refrigerator having a power-variable compressor of two-stage compression mode; and particularly relates to such refrigerator in which frequency of the compressor is decided in response to a temperature in a fresh-food compartment.

BACKGROUND OF THE INVENTION

[0002] Refrigerators equipped with compressors that are variable in power by inverter control have become widespread in recent years. Refrigeration capacity of such refrigerator is variable, so that cooling ability matching with refrigeration load is achieved; and thereby electric power consumption is reduced.

[0003] A refrigerators being widespread in household use is usually comprised of a freezer compartment cooled to about -18°C to -20°C and a fresh-food compartment maintained at about $+1^{\circ}\text{C}$ to 5°C . When only one compressor is used to cool both of the freezer and fresh-food compartments, distribution of cooled air flowing into the compartments is controlled by dampers or the like. In accordance with overall load on the refrigerator, driving and stopping of the compressor is made. When the compressor is on inverter control, frequency of the compressor is controlled in addition to the above. In this way, each of the storage compartments is maintained at a predetermined temperature.

[0004] When the refrigerator is equipped with two compressors respectively for the freezer and fresh-food compartments, flow channels for refrigerant are switched with each other as to distribute and control the refrigerant flow; and the compressors are controlled in response to overall workload for the storage compartments as a whole such as temperatures or temperature difference.

[0005] Meanwhile, the compressors in refrigerators now on sale in the market are of so-called single stage compression mode, that is, have a single compression unit in each of compressor casing. Nevertheless, idea of two-stage compression mode for a refrigerator apparatus as shown in FIG. 13 is disclosed in recent years. Please see JP2001-074325A (Japan's patent application publication 2001-74325) for example. It is constructed as follows as shown in the figure. Two-stage compressor 39 that has a low-pressure or lower-stage compression element 39a and a high-pressure or higher-stage compression element 39b, as well as an electric motor, are constructed in a sealed casing. Intermediate-pressure expansion equipment 43 is connected with outlet of a condenser 40 that is connected with outlet pipe 46 of the high-pressure compression element 39b. Intermediate-pressure suction pipe 47 and inlet of the high-pressure compression element 39b as well as outlet of the low-pressure compression element 39a are communicated with each other. An intermediate-pressure evaporator 35 is connected between the intermediate-pressure suction pipe 47 and the intermediate-pressure expansion equipment 43. Further, low-pressure evaporator 34 is connected between inlet 45 of the low-pressure compression unit 39a of the two-stage compressor 39 and low-pressure expansion equipment 42 that is connected with outlet of the condenser 40. By such construction, outlet of the low-pressure compression element 39a and inlet of the high-pressure compression ele-

ment 39b are communicated with each other, within the sealed casing of the compressor 39, so as to increase accuracy of temperature control in the compartments and to achieve uniform distribution of temperature in the compartments as well as high efficiency and low power consumption.

DISCLOSURE OF THE INVENTION

Problems to be Solved by the Invention

[0006] In the refrigerant circuit shown in JP2001-74325A, its efficiency improves when evaporation temperature in the intermediate-pressure evaporator 35, which is a cooler for the fresh-food compartment or fresh-food cooler, is higher than that of the low-pressure evaporator 34, which is a cooler for the freezer compartment or freezer cooler. Nevertheless, suction pipe of the freezer cooler 34 is directly connected to the low-pressure compression element 39a of the compressor and suction pipe 47 of the fresh-food cooler 35 is connected with intermediate-pressure room in the compressor 39; thus, refrigeration capacity for the freezer compartment is difficult to be influenced by refrigerant flowing through the fresh-food cooler 35. Thus, such conventional method in which frequency of the compressor is controlled in accordance with respective loads on freezer and fresh-food compartments as well as total load may cause a problem such as follows. When, for example, the freezer compartment is fully cooled and the fresh-food compartment is excessively cooled, frequency of the compressor will be lowered as to resultantly cause insufficient cooling of the freezer compartment.

[0007] The invention is made in view of the above problem, is aimed to provide a refrigerator in which each of the freezer and fresh-food compartments is maintained as properly controlled at a temperature for storage; by controlling the power-variable refrigerant circuit of two-stage compression mode having the freezer and fresh-food evaporators in accordance with temperature information for the freezer compartment.

MEANS TO SOLVE THE PROBLEMS

[0008] The invention-wise refrigerator, for solving the above problem, has a refrigerant circuit comprising: an inverter-driven power-variable compressor having a low-pressure compression element and a high-pressure compression element; a switching valve that selects and controls flow channel and flow rate of refrigerant and is disposed on downstream of a condenser, which receives gas refrigerant discharged from the compressor; and coolers or evaporators that are respectively for a freezer compartment and a fresh-food compartment and are connected to the switching valve through respective pressure reducers; and wherein frequency of the compressor is decided in response to temperature in the freezer compartment and its target temperature.

[0009] Meanwhile, according to claim 2, the invention-wise refrigerator has a refrigerant circuit comprising: an inverter-driven power-variable compressor having a low-pressure compression element and a high-pressure compression element; a switching valve that selects and controls flow channel and flow rate of refrigerant and is disposed on downstream of a condenser, which receives gas refrigerant

discharged from the compressor; and coolers or evaporators that are respectively for a freezer compartment and a fresh-food compartment and are connected to the switching valve through respective pressure reducers; and wherein frequency of the compressor is decided in response to temperature in the freezer compartment and its target temperature; and feedback rate or weighting of temperature information from the freezer compartment is made larger than that from the fresh-food compartment at a time of deciding the frequency of the compressor.

ADVANTAGEOUS EFFECT OF THE INVENTION

[0010] By such construction, evaporation temperatures in two coolers for the freezer and fresh-food compartments are set in accordance with extent of cooling of the compartments; thus, not only improvement of efficiency in the refrigerant cycle as well as switching between flow channels for the coolers and controlling flow rate of refrigerant are achieved; but also temperature fluctuations in the freezer and fresh-food compartments are suppressed as a result of simultaneous cooling of the compartments, so as to properly control the temperatures in the compartments.

BEST MODE FOR CARRYING OUT THE INVENTION

[0011] In following, first embodiment of the invention will be explained in dependence upon the drawings. FIG. 2 shows a vertical sectional view of a casing main body 1 of the refrigerator; and the casing main body 1 forms a storage space at inside of an insulator box and is partitioned to a plurality of storage chambers such as a freezer chamber and an ice-forming chamber in a freezer compartment 2 as well as a fresh-food chamber and a vegetable chamber in a fresh-food compartment 3.

[0012] Each of the storage chambers is cooled as maintained at a predetermined temperature by a freezer cooler 4 or a fresh-food cooler 5 and by a fan 6 or 7 for cooled air circulation. The freezer and fresh-food coolers 4 and 5 are cooled by refrigerant supplied from a compressor 9 that is arranged in a machine room 8 on rear-bottom part of the casing main body 1.

[0013] FIG. 1 shows a refrigerant circuit of the invention-wise refrigerator, in which the compressor 9, a condenser 10 and a switching valve 11 are connected and the freezer and fresh-food coolers 4 and 5 are further connected in a parallel arrangement, as to form a loop. The condenser 10 is in a flat shape and arranged on outer bottom face of the casing main body 1, at front of the machine room 8. Refrigerant that has been condensed at the condenser 10 is supplied through the switching valve 11 to a capillary 12 or 13 as a pressure reducer and then to the freezer cooler 4 or the fresh-food cooler 5. Evaporation of the refrigerant cools the cooler 4 or 5; and by air circulation by the cool-air fan 6 or 7, inside of the storage chambers are cooled to a predetermined air temperature. Then, such vaporized refrigerant is returned to the compressor, through an accumulator 14.

[0014] As to be notified and shown in detail on the FIG. 3, the compressor 9 is a two-stage reciprocating compressor, in which press pump part is comprised of a low-pressure compression element 9a and a high-pressure compression element 9b. Turning of a rotation shaft 9e of an electric

motor mechanism 9d that is kept in a sealed casing 9c causes turning of an eccentric shaft 9f as to thereby cause reciprocating motion of connecting rods 9g.

[0015] On end of the each connecting rod 9g, a piston 9i is secured by fitting engagement. Reciprocating motion of the pistons 9i within the cylinder 9j causes suction, compression and discharge of refrigerant, alternately by the low-pressure compression element 9a and the high-pressure compression element 9b. Ball joints 9h are adopted to the compression elements; and thereby improving volume-wise efficiency and curbing enlargement of contour size of the two-stage compressor 9 that requires two compression elements 9a and 9b.

[0016] Suction inlet 9k of the low-pressure compression element 9a is connected with an end of a suction pipe 15 that is connected to a freezer cooler 4 through an accumulator 14. The low-pressure compression element 9a has a discharge outlet 9m that is opened to inside of the sealed casing 9c and is to discharge compressed gas refrigerant. The high-pressure compression element 9b has a discharge outlet 9n that is connected to an outlet pipe 16 of the condenser 10.

[0017] The accumulator 14 serves to separate liquid refrigerant from gas refrigerant and to store the liquid refrigerant that has been left after passing the cooler 4, and thereby serves to send out only the gas refrigerant. Thus the accumulator 14 serves to curb a trouble that would otherwise occur when the liquid refrigerant were flowed into the cylinder 9j of the compressor 9. In this example, the accumulator is arranged only on downstream of the freezer cooler 4.

[0018] A suction pipe 17 from the fresh-food cooler 5 is connected to a room inside of the sealed casing 9c, in which pressure level is intermediate, so as to lead refrigerant into the room. Therefore, refrigerant sucked from the fresh-food cooler 5 does not directly flow into a cylinder of the compressor; and hence an accumulator is not necessarily required on downstream side of the fresh-food cooler 5. Even when installing an accumulator there, only a small one is enough. Gas refrigerant sucked through the suction pipe 17 is then sucked through a suction inlet 9p of the high-pressure compression element 9b and then compressed in the element, along with gas refrigerant discharged from the discharge outlet 9m of the low-pressure compression element 9a.

[0019] The compressor 9 is power variable by inverter control and is operated by a control device formed by a microcomputer or the like in a manner that; frequency is decided, within a range from 30 through 70 Hz for example, in accordance with temperatures detected in the freezer and fresh-food compartments, with their deviations from target temperatures, or with temperature variation rate or the like.

[0020] The switching valve 11 is arranged on downstream of the condenser 10 that receives gas refrigerant discharged from the compressor 9 and serves to switch between two refrigerant flow channels to the coolers 4 and 5 and to control flow rate of the refrigerant. As shown in FIG. 4, the switching valve 11 is a three-way valve, in which a valve seat 19 that is formed to have an "A" or first valve port 19a leading to the freezer cooler 4 and a "B" or second valve port 19b leading to the fresh-food cooler 5 is formed within a valve casing 18 and in which a closure element 20 is placed on the valve seat 19.

[0021] The closure element **20** has an “A” or first groove **20a** and a “B” or second groove **20b**, on bottom face of a thickly terraced part **20d** having a predetermined contour. These two grooves **20a** and **20b** have V-shaped cross section and run for predetermined distances along arches differing in radius from center of the rotation shaft **20c** in a manner to respectively cover the “A” valve port **19a** and the “B” valve port **19b** when tracing by a rotation. The closure element **20** is tightly overlaid on the valve seat **19** and is turn-wise driven by a not-illustrated stepping motor arranged above the valve at pulse steps in a range of 0-85.

[0022] As for the switching valve **11**, the closure element **20** is turned by pulse signal controlling the refrigerant circuit. When the “A” valve port **19a** and the “A” groove **20a** on distal side from rotational axis are overlapped with each other at predetermined pulse positions, they are communicated with each other. Then, refrigerant that is flowed into inside of the valve casing **18** by way of an inlet valve port **21** flows through an opening, of the “A” groove **20a**, on contour of the thickly terraced part **20d**, and to inside the “A” groove **20a** having V-shaped section. Subsequently, refrigerant is led through the “A” valve port **19a** in to a freezer capillary **12**, or a capillary for the freezer cooler, and is vaporized in the freezer cooler **4**.

[0023] When the “B” valve port **19b** and the “B” groove **20b** on proximal side from rotational axis are overlapped with each other as to be communicated with each other; refrigerant flowed into the “B” groove **20b** flows through the “B” valve port **19b** and into a fresh-food capillary **13**, or a capillary for the fresh-food cooler, and is evaporated in the fresh-food cooler **5**.

[0024] The “B” groove **20b** for the fresh-food cooler is constructed in a manner that area of its V-shaped cross section becomes progressively larger by approaching to the opening on the contour of the thickly terraced part **20d** and leaving from a turn-wise or arch-wise distal end. Thus, by turning of the closure element **20**, size of area for communication with the “B” valve port **19b** is varied from minimum to maximum. In this way, switching between refrigerant channels and adjustment of the flow rate are subtly controllable; and the flow rate of refrigerant is efficiently and linearly varied by turn-wise control with pulses.

[0025] For control of openness of the three-way valve **20**, selection may be made among following: full opening of valve ports **19a** and **19b** for the freezer and fresh-food coolers **4** and **5**; full closure of the two valve ports; narrowing down of the valve port for the freezer cooler while fully opening the valve port for the fresh-food cooler; narrowing down of the valve port for the fresh-food cooler while fully opening the valve port for the freezer cooler; and the like. In the example, while the freezer cooler **4** and the fresh-food cooler **5** are connected in a parallel arrangement, cooling control is made by selecting between two occasions, namely, an occasion of simultaneous cooling of the freezer and fresh-food compartments and an occasion of cooling only the freezer compartment.

[0026] Refrigerant flowed out from the valve port **19a** for the freezer cooler passes through the freezer capillary **12** as to be depressurized and then evaporates in the freezer cooler **4** at about -25°C . The capillary **12** is constructed to achieve such evaporation temperature corresponding to a cooling temperature that should be achieved in the freezer compart-

ment **2**. In same manner as above, refrigerant flowed out from the valve port **19b** for the fresh-food cooler flows to and evaporates in the fresh-food cooler **5** after passing through the capillary **13**; which is constructed to achieve evaporation temperature at about -5°C that is close to a cooling temperature being should achieved in the fresh-food compartment **3**.

[0027] The capillary **12** and **13** for the freezer and fresh-food coolers in the refrigerant circuit are constructed as follows. In order to differentiate the evaporation temperatures in the freezer and fresh-food coolers **4** and **5**, throttling is more intensive in the capillary **12** for the freezer cooler than in the other. This construction entails that refrigerant is apt to flow more through the capillary **13** having smaller resistance, for the fresh-food cooler **5**; and refrigerant flow through the capillary for the freezer cooler becomes difficult, and might be even stopped at some extreme occasion.

[0028] To improve the above, controlling of the switching valve **11** is made to slightly narrow down a flow passage to the fresh-food cooler, to which refrigerant more apt to flow, for curbing so-called one-sided refrigerant flow, in addition to controlling of the flow of refrigerant for cooling freezer and fresh-food compartments **2** and **3**.

[0029] Resultantly, when the groove **20a** and valve port **19a** for the freezer cooler are communicated to fully open the valve port, the freezer cooler **4** exhibits an almost constant cooling capacity, almost irrespective to refrigerant flow rate through the fresh-food cooler. Thus, cooling capacity in the freezer compartment is subtly controllable by an extent of openness or closure of the valve port **19b** or communication between the groove **20b** and the valve port **19b**, and by variation of frequency of the compressor **9**.

[0030] By such control of refrigerant flow, evaporation temperature in the fresh-food cooler **5** is set to be significantly higher than that in the freezer cooler so as to achieve cooling at $+1^{\circ}\text{C}$ to 2°C in a fresh-food chamber. When heat-transmitting surface area on the fresh-food cooler **5** is increased as to increase heat exchange capacity for cooling the fresh-food compartment, then the evaporation temperature in the cooler maybe further enhanced. In such occasion, difference between the cooling temperature in the fresh-food compartment **3** and temperature of the cooler **5** is decreased as to decrease an amount of frost stuck on the fresh-food cooler **5** and to achieve curbing of drying in the compartment and keep humidity in the compartment as high.

[0031] In a general household refrigerator, cooling capacities required for the freezer and fresh-food compartments are almost equal. Thus, efficient cooling is achieved when heat-transmitting surface area on the fresh-food cooler **5** is set to be same level with or higher than that of the freezer cooler **4**.

[0032] In following, operation of the refrigerant circuit is explained. On turning on of the power, the compressor **9** is driven, and gas refrigerant at high temperature and at high pressure is discharged from outlet pipe **16** into the condenser **10** and arrives in the switching valve **11**. Whereas the switching valve **11** may be set with various pattern of control as explained in the above, the valve ports **19a** and **19b** are fully opened when the power is just turned on because then the freezer and fresh-food compartments **2** and **3** are yet to be cooled. Thus, refrigerant flows into and depressurized in

the capillaries 12 and 13 for the freezer and fresh-food coolers and evaporates in the freezer and fresh-food coolers 4 and 5 at respective evaporation temperatures as to cool the coolers to predetermined temperatures.

[0033] Refrigerant flowed out from the freezer cooler 4 flows into the accumulator 14. If some liquid refrigerant is left after passing through the cooler, the liquid refrigerant yet to be vaporized is stored in the accumulator 14 and only gas refrigerant passes through the suction pipe 15 and is sucked into the low-pressure element 9a in the compressor 9. Meanwhile, gas refrigerant having vaporized in the fresh-food cooler 5 passes through the suction pipe 17 and is introduced into inside of the sealed casing 9c of the compressor 9c, which is at an intermediate pressure.

[0034] Gas refrigerant that has been sucked into the low-pressure compression element 9a from the freezer cooler 4 and compressed and discharged through the outlet 9m into inside of the sealed casing 9c merges with gas refrigerant that has been flowed from the fresh-food cooler 5 into inside of the sealed casing 9c. Then, such merged stream of gas refrigerant is sucked through an inlet 9p into the high-pressure compression element 9b and is discharged through an outlet 9n into the outlet pipe 16 to be led into the condenser 10. In this way, the refrigerant circuit is formed.

[0035] In the above refrigerant circuit, the freezer and fresh-food coolers 4 and 5 are respectively provided with the capillaries 12 and 13 in a manner that; evaporation temperatures at the coolers are suited for predetermined temperatures in the freezer and fresh-food compartments 2 and 3, respectively. Gas refrigerant vaporized in the fresh-food cooler 5 is then directly sucked into the intermediate-pressure room in the sealed casing 9c while being kept at an intermediate pressure that is higher than a pressure in the freezer cooler. In this way, the evaporation temperature in the fresh-food cooler 5 may be set higher than that in the freezer cooler 4, in accordance with cooling temperature in the compartments. Moreover, input power for the compressor is reduced, and thereby, efficiency of the refrigerant circuit is increased and power consumption is reduced.

[0036] Further, amount of the frost stuck on the cooler 5 is decreased by raising evaporation temperature in the fresh-food cooler 5 as to decrease temperature difference between the cooler and inside of the fresh-food compartment. Thus, drying in the fresh-food compartment is curbed and humidity is kept high so that freshness of food is kept for a long period. Moreover, because refrigerant may flow simultaneously through the freezer and fresh-food coolers 4 and 5, temperature fluctuation is smaller than a conventional way of alternately cooling the coolers.

[0037] The refrigerant circuit may in otherwise be constructed as shown in FIG. 5, in which reference marks same with FIG. 1 are attached. While the compressor 9, the condenser 10 and the switching valve 11 are same as above, the freezer cooler 4 and the fresh-food cooler 5 are connected in a serial arrangement. Moreover, a bypass pipe 22 for bypassing the fresh-food capillary 13 and the fresh-food cooler 5 runs from the switching valve 11 and connected with a gas-liquid separator 23, which is connected with the freezer capillary 12 and there through to the freezer cooler 4. A suction pipe 24 connects between upper portion of the gas-liquid separator 23 and the intermediate-pressure room within the sealed casing 9c of the compressor 9.

[0038] Resultantly, refrigerant flows through both of or either of the freezer cooler 4 and the fresh-food cooler 5 by the switching valve that is controlled as in the above. Refrigerant flowed from the bypass pipe 22 or the fresh-food evaporator 5 flows into the gas-liquid separator 23 and is subjected to separation between gas refrigerant and liquid refrigerant. From the separator 23, the gas refrigerant flows through fresh-food suction pipe 24 and goes back to the intermediate-pressure room in the compressor 9; and the liquid refrigerant evaporates at low temperature in the freezer cooler 4 and then goes back to low-pressure compression element of the compressor 9. As in the previous example, cooling of the compartments at predetermined temperatures is made with satisfactory efficiency in respect of the refrigerant circuit.

[0039] FIG. 6 shows-refrigeration capacity of the freezer cooler 4 and the fresh-food cooler where temperatures of the coolers and temperature of the condenser are taken as constant and the compressor 9 is operated at a constant frequency. In the figure, the ordinate represents refrigeration capacity of the fresh-food cooler 5; and the abscissa represents refrigeration capacity of the freezer cooler 4. As appeared in the figure, point "a" represents an occasion in which refrigerant flows only through the fresh-food cooler 5 as a result of switching of the switching valve; point "b" represents an occasion in which refrigerant flows only through the freezer cooler 4; and "c" represents an occasion in which refrigerant flows through both of the freezer and fresh-food coolers 4 and 5 while the valve ports 19a and 19b are fully opened.

[0040] In this graph, mass or volume of refrigerant that is directly sucked into the low-pressure compression element 9a from the freezer cooler 4 is determined by an excluded volume of the cylinder in the low-pressure compression element 9a. Refrigeration capacity corresponding such sucking is 69W when refrigerant flows only through the freezer cooler, and is 64W when refrigerant flows through both of the freezer and fresh-food coolers. Thus, refrigeration capacity for the freezer is nearly constant and is not greatly affected by return-wise flowing of refrigerant from the fresh-food cooler 5 into the intermediate-pressure room in the compressor 9.

[0041] On contrary, the refrigeration capacity of the fresh-food cooler, which corresponds sucking of refrigerant from the fresh-food cooler 5 into the compressor 9, is 155 W when flowing only through the fresh-food cooler 5, and is 75 W as greatly decreased when flowing through both of the freezer and fresh-food coolers. In this way, the refrigeration capacity of the fresh-food cooler is greatly varied by situations whether the refrigerant is sucked from the freezer cooler or not; namely whether refrigerant is sucked into the compressor only from the fresh-food cooler 5 or from both of the freezer and fresh-food coolers 4 and 5 as merged with each other.

[0042] Generally, temperature at inside of the fresh-food compartment is +3°C to 5°C while temperature at inside of the freezer compartment is -18°C to -20°C. Thus, for the freezer compartment, temperature difference from that of the air is great, and hence, refrigeration capacity larger than that for the fresh-food compartment is usually required. If refrigeration capacity for the freezer, namely refrigeration load for the freezer, is recognized to be larger than that for the fresh

food, refrigeration operation is made as indicated by hatched area in the FIG. 7 that schematically depicts the FIG. 6. In the hatched area, refrigeration capacity for the freezer is superior.

[0043] As mentioned above, refrigeration capacity for the freezer is not remarkably affected by flowing back of refrigerant from the fresh-food cooler 5. Thus, refrigeration control for the freezer compartment may be made by control of frequency of the compressor 9. When cooling is not enough, the frequency of the compressor 9 is increased as to increase the refrigeration capacity. When cooling is excessive, the frequency of the compressor 9 is decreased or the compressor 9 is stopped so as to keep proper cooling temperature. Meanwhile, as for the cooling of the fresh-food compartment, openness or closure of the valve port in the switching valve 11 is controlled instead of the frequency of the compressor, so as to control flow rate of refrigerant and thereby control cooling temperature in the fresh-food compartment.

[0044] By use of FIG. 8, which is a control block diagram, it is explained a first example of invention-wise controlling of frequency of the compressor. A temperature "Fa" at inside of the freezer compartment 2 which is detected by a freezer temperature sensor, in a freezer chamber for example, is compared with a predetermined target temperature "Fr"; and difference between them is inputted to PID controller 25 that is for deciding frequency of the compressor.

[0045] If the temperature "Fa" in the freezer compartment 2 is higher than the target temperature "Fr", PID calculated value becomes high. Then, an operational control is made such that cooling of the freezer compartment 2 is induced to reach the target temperature by increasing frequency of the compressor in a predetermined extent. If the temperature "Fa" in the freezer compartment 2 is lower than the target temperature "Fr", the frequency of the compressor is decreased or the compressor is stopped so as to suppress refrigeration capacity.

[0046] In following, another example of invention-wise controlling of frequency of the compressor is explained. In the previous example, the frequency of the compressor is controlled on basis of temperature information for inside of the freezer compartment; and it is conceivable that refrigeration capacity of the fresh-food compartment may become insufficient under some operational conditions.

[0047] In view of the above, temperature information for the freezer compartment 2 is also inputted along with that for the fresh-food compartment 3 in a manner to make an operation of the compressor 9 within the hatched area on the FIG. 7. Then, frequency of the compressor 9 is increased and thus the refrigeration capacity is increased not only for the freezer compartment 2 but also for the fresh-food compartment 3.

[0048] Nevertheless, if the freezer compartment 2 is cooled to a temperature not more than the target temperature, frequency increase of the compressor 9 causes unnecessary cooling of the freezer compartment 2 and wasteful consumption of the electric power. In view of this, in a block diagram shown in FIG. 9, frequency of the compressor 9 is determined as below, while the PID controller 25 is inputted with not only the temperature "Fa" of the freezer compartment and its target temperature "Fr" but also the temperature

"Ra" of the fresh-food compartment and its target temperature "Rr". Feedback rate of information on temperature of the freezer compartment 2 is made higher than that of the fresh-food compartment 3. For example, data value on difference between the temperature "Fa" of the freezer compartment and its target temperature "Fr" is multiplied by two, so that such multiplied data value is added as inputted.

[0049] In this way, frequency of the compressor 9 is determined by laying emphasis on the freezer compartment by use of an overestimated difference value as feedback temperature information on freezer compartment 2. When the freezer compartment 2 has been fully cooled, refrigeration capacity of the fresh-food cooler is enhanced or suppressed by controlling rate of refrigerant flow through the fresh-food cooler 5 by use of the switching valve 11, not by enhancing frequency of the compressor. By such way of controlling, excessive cooling of the freezer cooler is curbed and the fresh-food compartment is kept in a proper temperature range.

[0050] In the above example, explanation is made for an occasion in which frequency of the compressor 9 is determined by taking into account temperature information for the fresh-food compartment 3. If temperature of the air at outside were decreased and temperature in the fresh-food compartment 3 became lower than the target temperature "Rr", there would arise a problem that frequency of the compressor 9 becomes lower and resultantly refrigeration capacity for the freezer compartment 2 becomes low.

[0051] FIG. 10 is a block diagram for coping with such an occasion. When and only when temperature in the fresh-food compartment 3 is higher than its target temperature "Rr", a function "Fx" for feeding back temperature information for the fresh-food compartment is introduced. When the temperature "Ra" in the fresh-food compartment and its target temperature value "Rr" make small difference, such target temperature value is inputted to the PID controller 25. When deviation from the target temperature is minus value, signal of zero value is inputted to the PID controller 25.

[0052] As a result of such manner of controlling, even when load for the fresh-food compartment 3 is small and thereby actual temperature "Ra" in the compartment is smaller than its target temperature "Rr", temperature in the freezer compartment 2 is by use of its temperature information, maintained at the target temperature "Fr". Thus, it is curbed that temperature in the freezer compartment 2 becomes higher than the target temperature "Fr".

[0053] A still another example is explained. FIG. 11 shows variation of refrigeration capacity "QF1" for the freezer cooler and of refrigeration capacity "QR1" for the fresh-food cooler where; the compressor 9 is driven at a constant frequency, condenser temperature is constant and temperature of the fresh-food cooler 5 is varied.

[0054] As for the fresh-food cooler 5, the refrigeration capacity "QR1" is decreased by decreasing surface temperature of the cooler and is increased by increasing the surface temperature of the cooler. As for the freezer cooler, surface temperature is constant, and is -23.5°C for example; and the refrigeration capacity "QF1" of the freezer cooler is not greatly affected by variation of the refrigeration capacity of the fresh-food cooler.

[0055] In respect of the fresh-food cooler 5, when frequency of a fan 7 for the fresh-food cooler 5, or fresh-food

fan 7, is decreased, heat exchange rate on the cooler 5 is decreased as to decrease surface temperature of the cooler 5 and resultantly, the refrigeration capacity "QR1" of the fresh-food cooler is decreased. Inversely, when the frequency of the fresh-food fan 7 is decreased, heat exchange rate on the cooler 5 is increased as to increase surface temperature of the cooler 5 and resultantly, the refrigeration capacity "QR1" of the fresh-food cooler is increased.

[0056] Hence, as for refrigeration control for the fresh-food compartment 3, temperature in the compartment may be controlled by increasing and decreasing of the frequency of the fresh-food fan 7. When the temperature "Ra" in the fresh-food compartment is higher than its target temperature "Rr", cooling may be made by increasing the frequency of the fresh-food fan 7. When the compartment is excessively cooled below the target temperature "Rr", the frequency of the fan is decreased as to weaken the refrigeration ability. In this way, controlling for keeping at proper temperature is made.

[0057] FIG. 12 shows variation of refrigeration capacity "QF2" for the freezer cooler and of refrigeration capacity "QR2" for the fresh-food cooler where; the temperature of the freezer cooler 4 is varied. By decreasing the temperature of the freezer cooler 4, flow rate of refrigerant passing through the freezer cooler 4 as to be sucked into the low-pressure compressor element is decreased so that the refrigeration capacity "QF2" of the freezer cooler is decreased. Moreover, flow rate of refrigerant passing into the high-pressure compression element from the low-pressure compression element is also decreased. Thus, in view of excluded volume of the high-pressure compression element, flow rate of refrigerant passing from the fresh-food cooler 5 to the intermediate-pressure room and then sucked to the high-pressure compression element is increased so that the refrigeration capacity "QR2" of the fresh-food cooler is increased.

[0058] In view of the above, when temperature in the fresh-food compartment 3 is higher than the target temperature "Rr" and cooling is insufficient, or when the refrigeration capacity for the freezer compartment 2 is excessive; frequency of a fan 6 for the freezer compartment, or the freezer fan 6, is decreased so as to decrease heat exchange rate on the freezer cooler 4, or in otherwise, the refrigeration capacity "QR2" of the fresh-food cooler is decreased. In this way, controlling for keeping the freezer and fresh-food compartments at proper temperatures is made.

[0059] The refrigeration circuit explained hereto enables simultaneous flowing of refrigerant through both of the freezer and fresh-food coolers 4 and 5. Thus, compared to a conventional one in which refrigerant is alternately flows into the freezer and fresh-food coolers, flowing of refrigerant would not become one-sided to either of the coolers; and an amount of refrigerant required to the refrigerant circuit does not become unnecessarily large. Hence, amount of refrigerant is kept small even when adopting a flammable refrigerant such as hydrocarbon compounds, as to improve safety.

[0060] In respect of the two-stage compressor 9 in the above examples, while it is explained that inside of the compressor casing 9c is kept at an intermediate pressure, it may be also constructed as follows though not illustrated. A suction pipe from the freezer cooler may be communicated with a room inside of the compressor casing, as a low-

pressure casing; and then a suction pipe from the fresh-food cooler is connected to a junction at which outlet of the low-pressure compression element is joined with the inlet of the high-pressure compression element. In otherwise, a suction pipe from the freezer cooler may be communicated with a room inside of the compressor casing, as a high-pressure casing; then, a suction pipe from the fresh-food cooler is connected to the junction at which outlet of the low-pressure compression element is joined with the inlet of the high-pressure compression element; and gas refrigerant discharged from the high-pressure compression element is sent out through inside of the casing at high pressure, to an outlet pipe to the condenser.

INDUSTRIAL APPLICABILITY

[0061] The invention is applicable to a refrigerator that has an improved efficiency of a refrigerant circuit by a construction of a two-stage compressor.

BRIEF DESCRIPTION OF THE DRAWING

[0062] FIG. 1 is a diagram of a refrigerant circuit of a refrigerator according to first embodiment of the invention;

[0063] FIG. 2 is a schematic vertical sectional view of a refrigerator having the refrigerant circuit of FIG. 1;

[0064] FIG. 3 is a vertical sectional view showing a detail of a two-stage compressor shown in FIG. 1;

[0065] FIG. 4 is a plan view showing an essential part of the three-way valve shown in the FIG. 1;

[0066] FIG. 5 is a construction diagram showing another embodiment of the refrigerant circuit;

[0067] FIG. 6 is a graph of a relationship between refrigeration capacities of the freezer and fresh-food coolers as well as flow rate;

[0068] FIG. 7 is a schematic expression of the FIG. 6;

[0069] FIG. 8 is a block diagram on controlling of frequency of the compressor;

[0070] FIG. 9 is a block diagram on controlling of frequency of the compressor, where information on temperature in the fresh-food compartment is added to the block diagram on FIG. 8;

[0071] FIG. 10 is a block diagram on the controlling, which is further improved from that of FIG. 9;

[0072] FIG. 11 is an explanatory view showing variation of refrigeration capacities of the freezer cooler and the fresh-food cooler when temperature of the fresh-food cooler is varied;

[0073] FIG. 12 is an explanatory view showing variation of refrigeration capacities of the freezer cooler and the fresh-food cooler when temperature of the freezer cooler is varied; and

[0074] FIG. 13 is a diagram of a refrigerant circuit of a conventional refrigerator.

REFERENCE NUMERALS OR MARKS

[0075] 1 casing main body; 2 freezer compartment; 3 fresh-food compartment; 4 freezer cooler; 5 fresh-food cooler, or cooler for fresh-food compartment; 6 and 7

cooling fans; **8** machine room; two-stage compressor; **9a** low-pressure compression element; **9b** high-pressure compression element; **9c** casing; **10** condenser; **11** switching valve; **12** capillary for freezer cooler; **13** capillary for fresh-food cooler; **14** accumulator; **15** suction pipe from the freezer cooler; **16** outlet pipe; **17** and **24** suction pipes from the fresh-food cooler; **18** valve casing; **19** valve seat; **19a** valve port "A" for the freezer cooler; **19b** valve port "B" for the freezer cooler; **20** closure body of the valve; **20a** groove "A" for freezer cooler; **20b** groove "B" for fresh-food cooler; **20c** rotation shaft; **20d** thickly terraced part; **21** inlet valve port; **22** bypass pipe; **23** liquid-gas separator; **25** PID controller

1. A refrigerator having a refrigerant circuit comprising:

an inverter-driven power-variable compressor having a low-pressure compression element and a high-pressure compression element; a switching valve that is disposed on downstream of a condenser receiving gas refrigerant discharged from the compressor and selects and controls flow channel and flow rate of refrigerant; and coolers, for freezer and fresh-food compartments, each connected with the switching valve through a pressure reducer; and wherein frequency of the compressor is decided by temperature in the freezer compartment and its target temperature.

2. A refrigerator having a refrigerant circuit comprising:

an inverter-driven power-variable compressor having a low-pressure compression element and a high-pressure compression element; a switching valve that is disposed on downstream of a condenser receiving gas refrigerant discharged from the compressor and selects and controls channel and rate of flowing of the refrigerant; and coolers, for freezer and fresh-food compartments, each connected with the switching valve through a pressure reducer; and wherein frequency of the compressor is decided by temperature in the fresh-food compartment and its target temperature and wherein on deciding of the frequency, feedback rate of temperature information from the freezer compartment is set larger than that from the fresh-food compartment.

3. A refrigerator according to claim 2, wherein, only when temperature of the fresh-food compartment is higher than its target temperature, information on such temperature is adopted in deciding the frequency of the compressor.

4. A refrigerator according to claim 1, wherein, when temperature of the fresh-food compartment is higher than its target temperature, frequency of a fresh-food cooling fan is increased.

5. A refrigerator according to claim 1, wherein, when temperature of the fresh-food compartment is higher than its target temperature, frequency of a freezer cooling fan is increased.

6. A refrigerator according to claim 2, wherein, when temperature of the fresh-food compartment is higher than its target temperature, frequency of a fresh-food cooling fan is increased.

7. A refrigerator according to claim 3, wherein, when temperature of the fresh-food compartment is higher than its target temperature, frequency of a fresh-food cooling fan is increased.

8. A refrigerator according to claim 2, wherein, when temperature of the fresh-food compartment is higher than its target temperature, frequency of a freezer cooling fan is increased.

9. A refrigerator according to claim 3, wherein, when temperature of the fresh-food compartment is higher than its target temperature, frequency of a freezer cooling fan is increased.

10. A refrigerator according to claim 4, wherein, when temperature of the fresh-food compartment is higher than its target temperature, frequency of a freezer cooling fan is increased.

11. A refrigerator according to claim 6, wherein, when temperature of the fresh-food compartment is higher than its target temperature, frequency of a freezer cooling fan is increased.

12. A refrigerator according to claim 7, wherein, when temperature of the fresh-food compartment is higher than its target temperature, frequency of a freezer cooling fan is increased.

* * * * *