



US 20070135907A1

(19) **United States**

(12) **Patent Application Publication**
Wilson et al.

(10) **Pub. No.: US 2007/0135907 A1**

(43) **Pub. Date: Jun. 14, 2007**

(54) **STENT WITH EXPANDABLE FOAM**

(22) Filed: **Nov. 29, 2006**

(75) Inventors: **Thomas S. Wilson**, Castro Valley, CA (US); **Duncan J. Maitland**, Pleasant Hill, CA (US); **Ward Small IV**, Livermore, CA (US); **Patrick R. Buckley**, Alameda, CA (US); **William J. Bennett**, Livermore, CA (US); **Jonathan Hartman**, Sacramento, CA (US); **David A. Saloner**, San Rafael, CA (US)

Related U.S. Application Data

(63) Continuation-in-part of application No. 10/801,355, filed on Mar. 15, 2004.

(60) Provisional application No. 60/508,808, filed on Oct. 2, 2003.

Publication Classification

(51) **Int. Cl.**
A61F 2/06 (2006.01)

(52) **U.S. Cl.** **623/1.44**

Correspondence Address:

Eddie E. Scott

Assistant Laboratory Counsel

Lawrence Livermore National Laboratory

P.O. Box 808, L-703

Livermore, CA 94551 (US)

(57) **ABSTRACT**

(73) Assignee: **The Regents of the University of California**

A stent for treating a physical anomaly. The stent includes a skeletal support structure for expanding in the physical anomaly and a shape memory material coupled to the skeletal support structure.

(21) Appl. No.: **11/606,620**

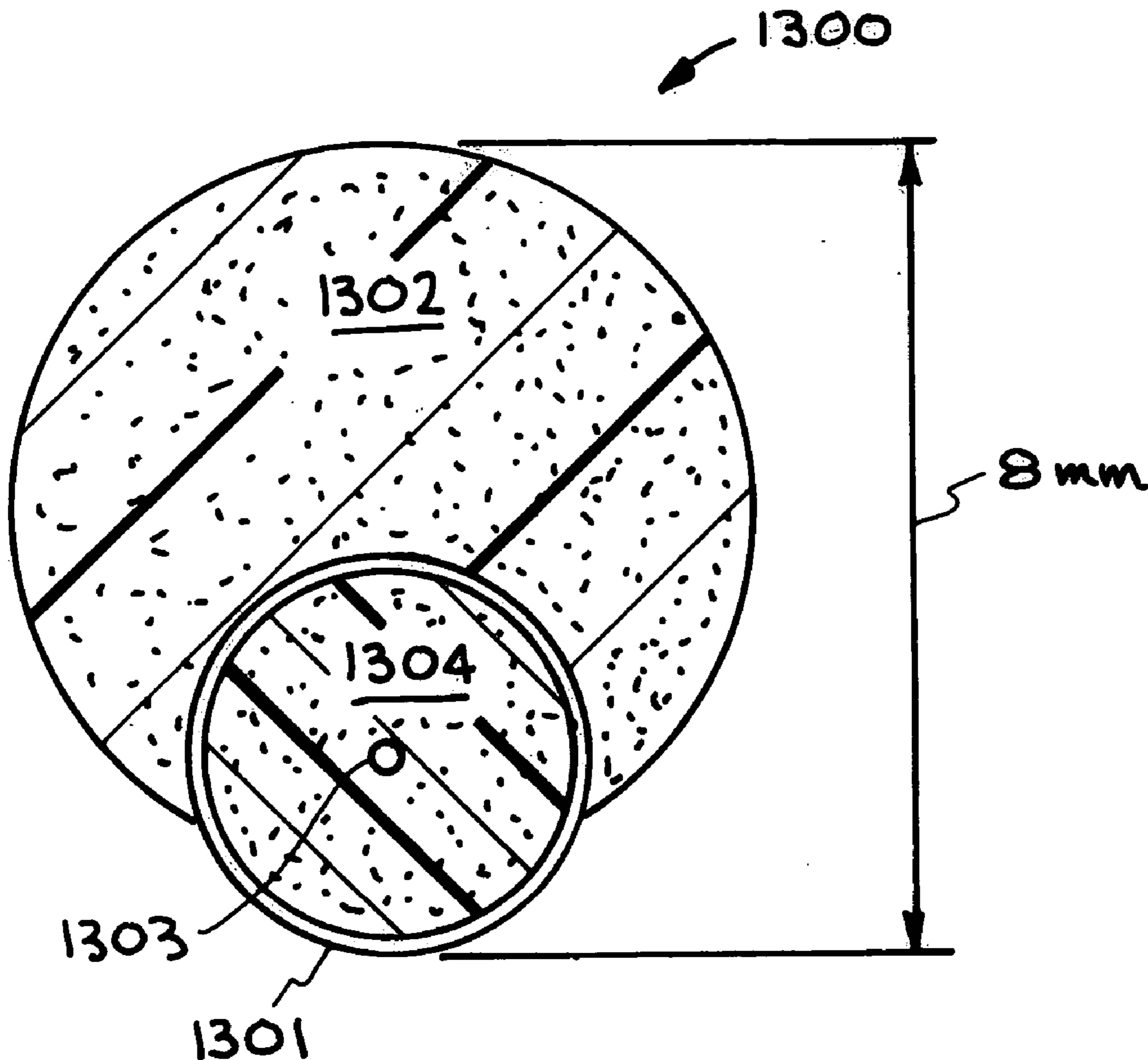

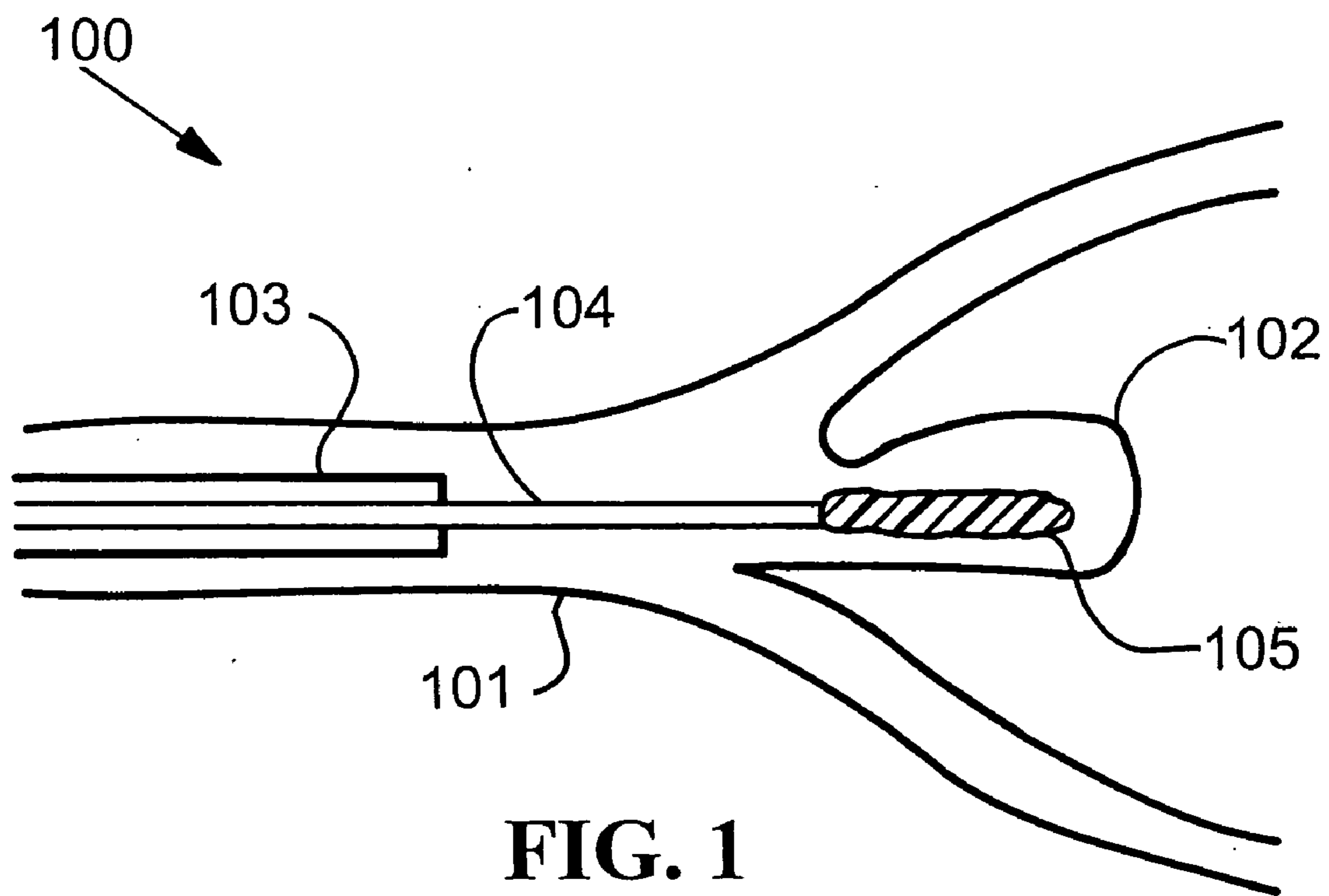

FIG. 1

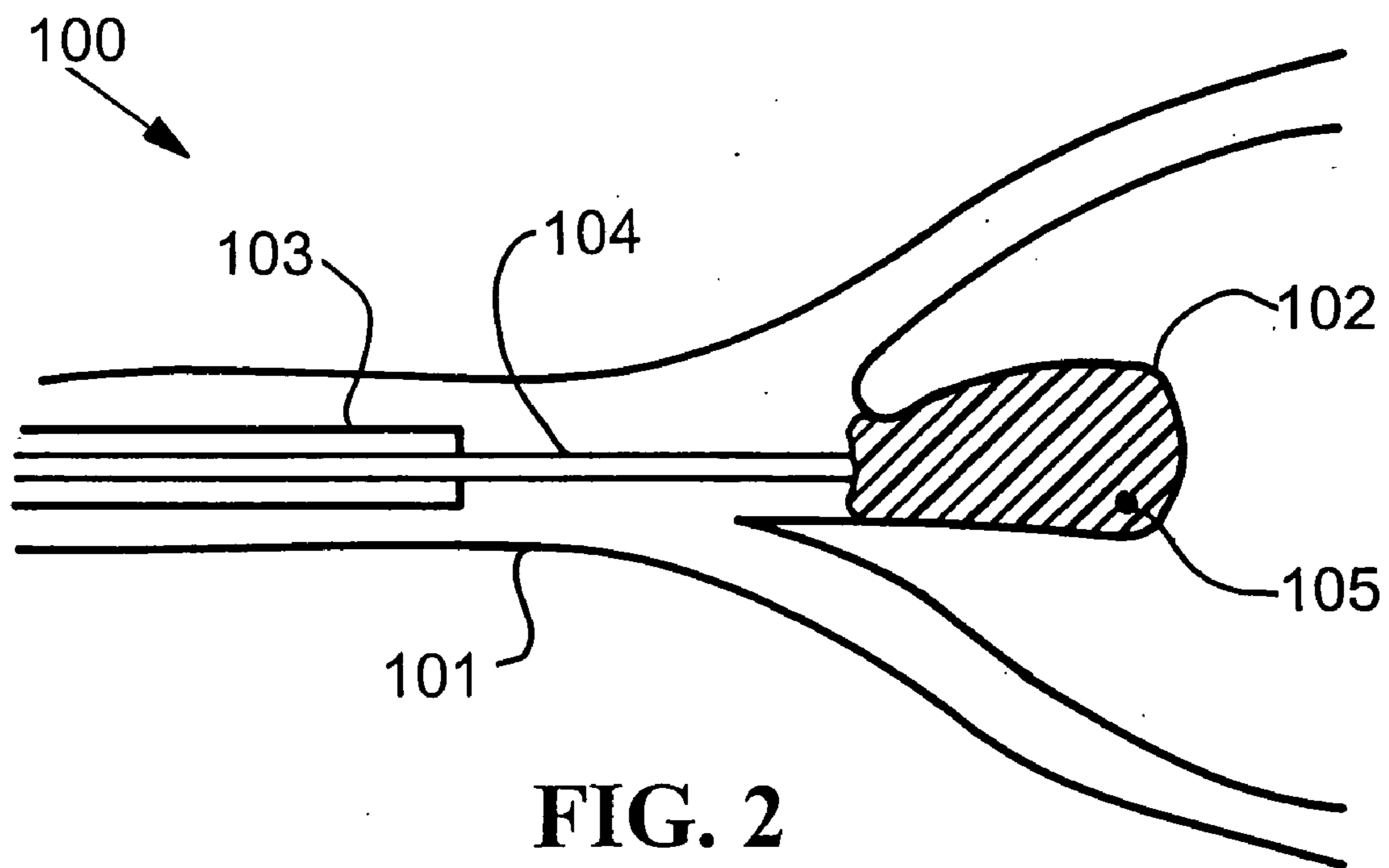

FIG. 2

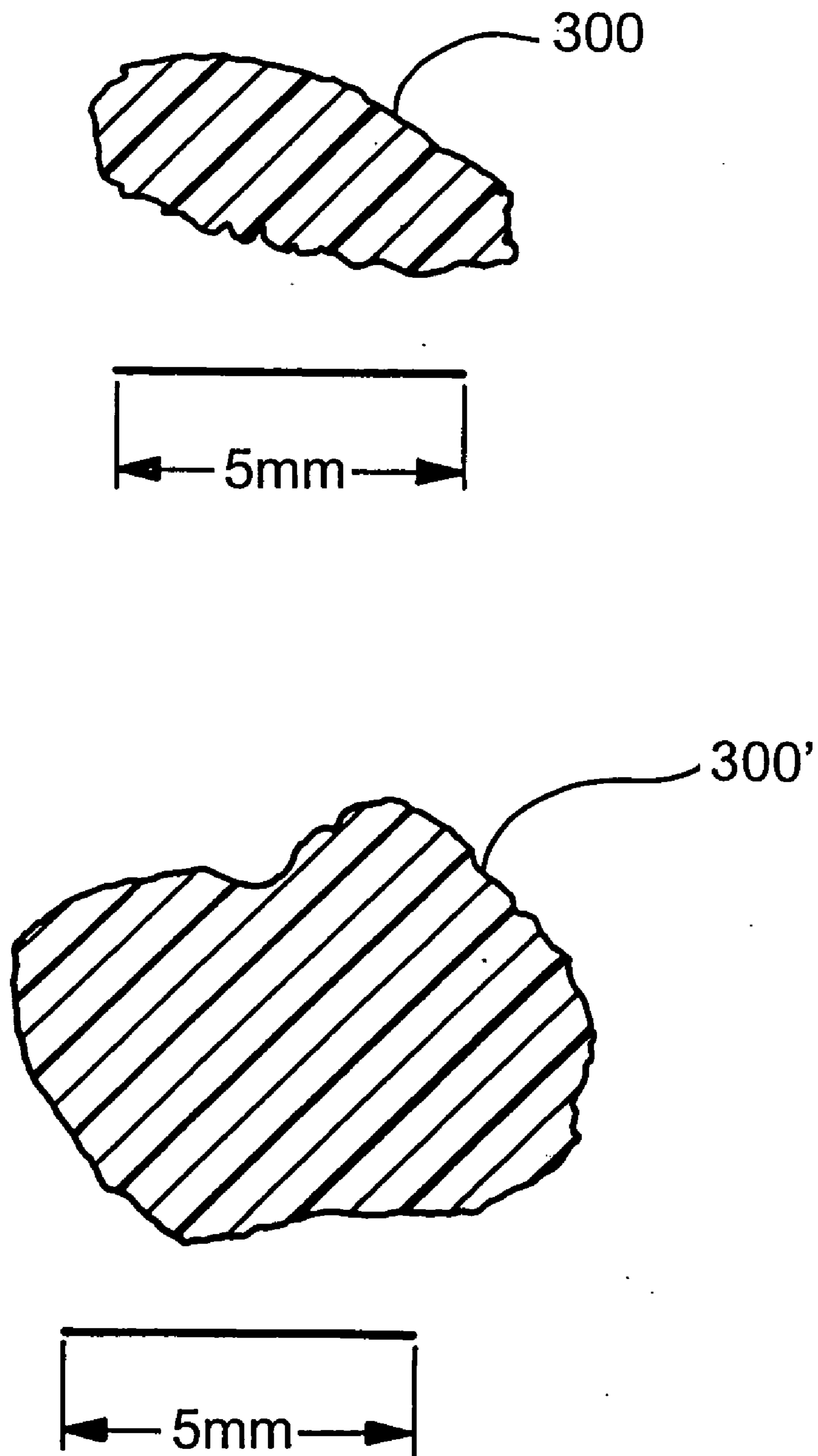

FIG. 3

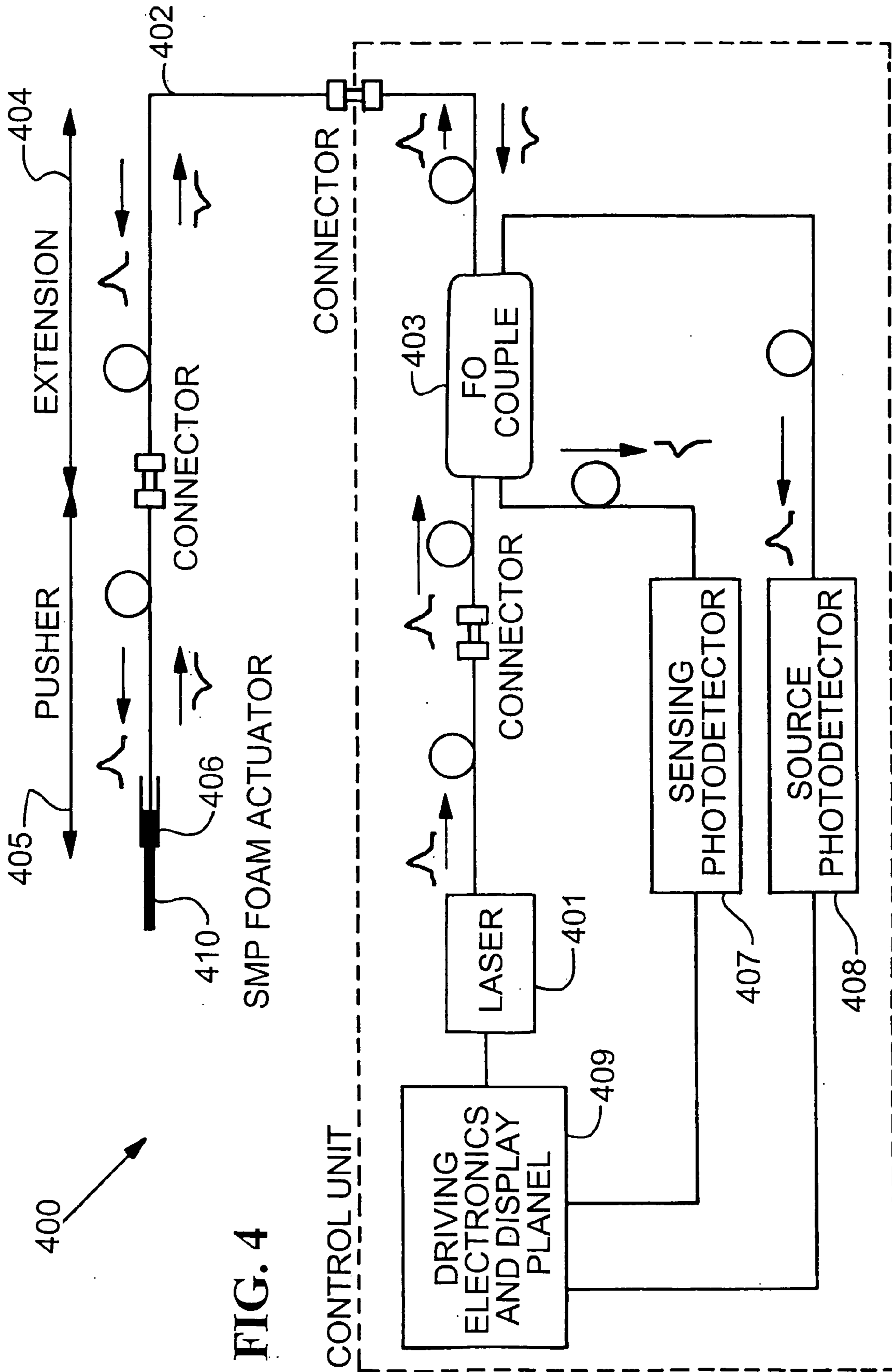

FIG. 4 SMP FOAM ACTUATOR

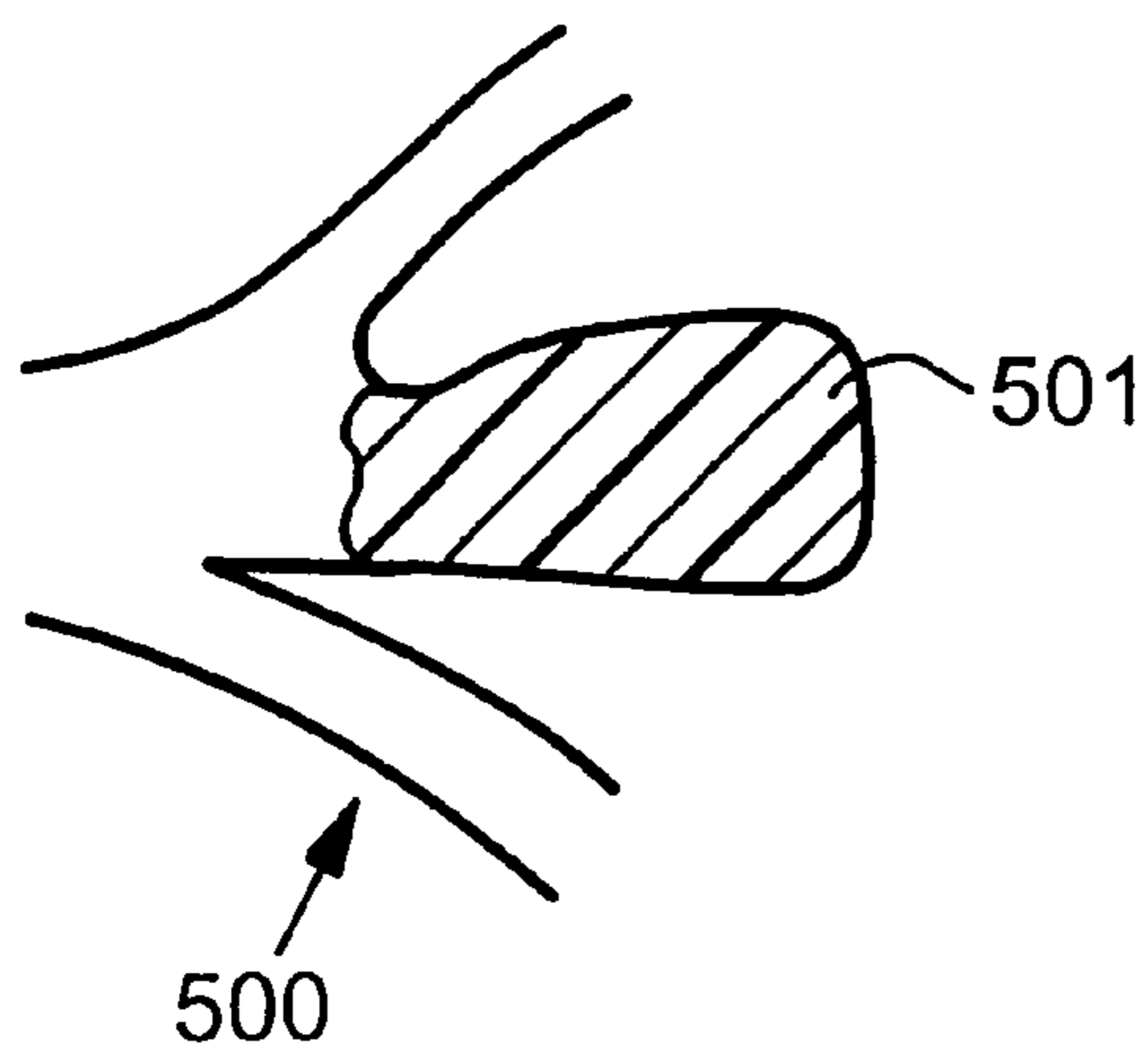

FIG. 5

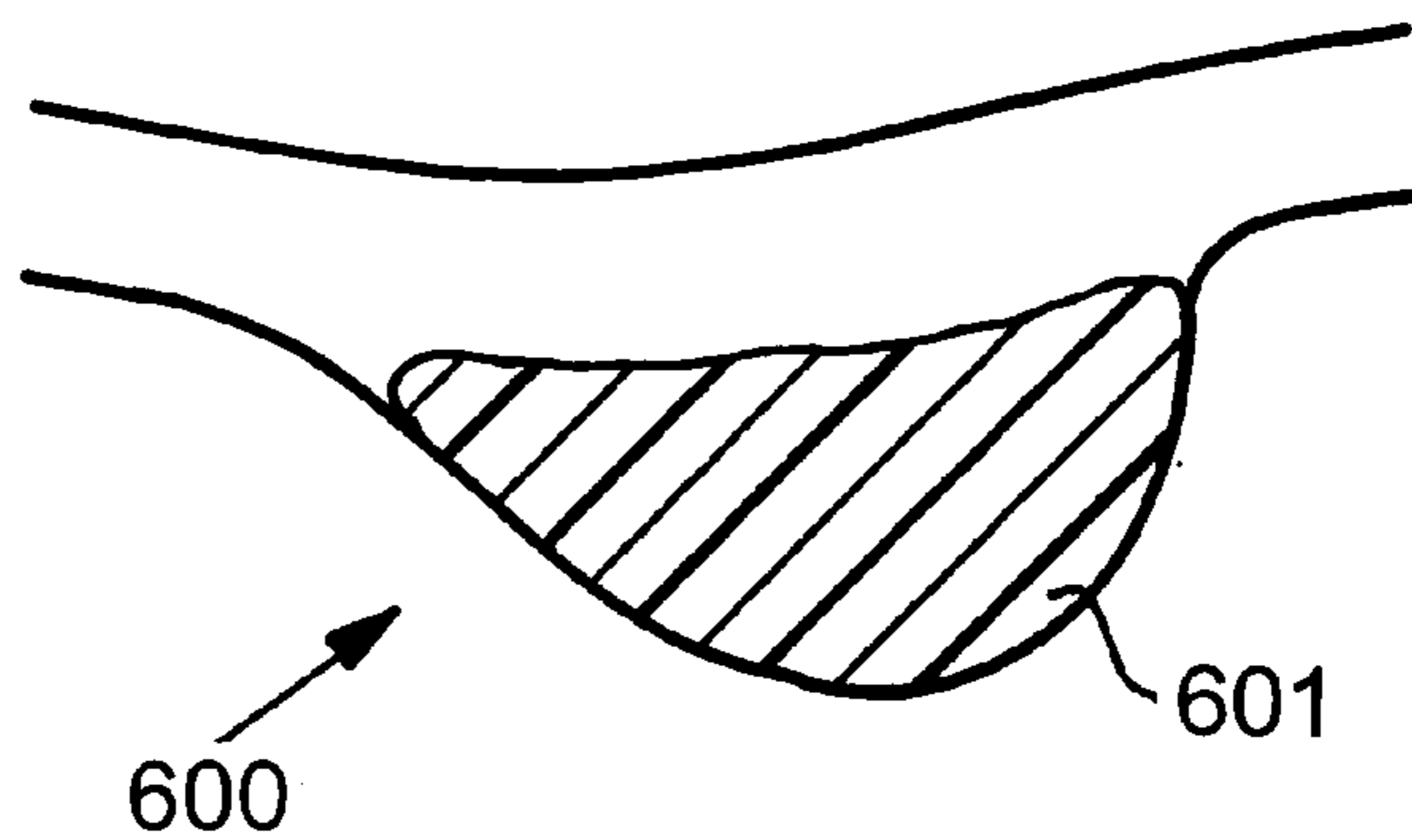

FIG. 6

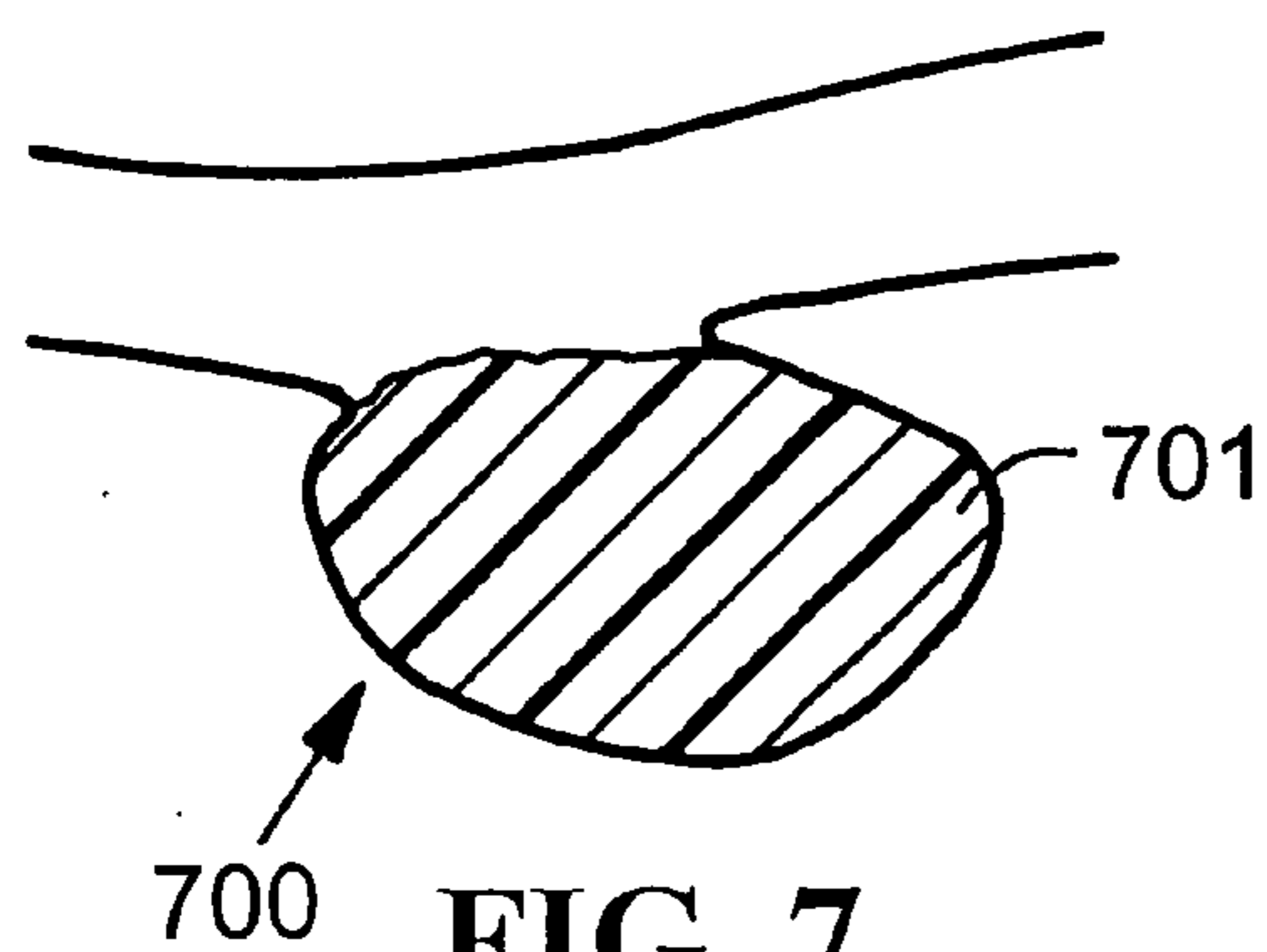

FIG. 7

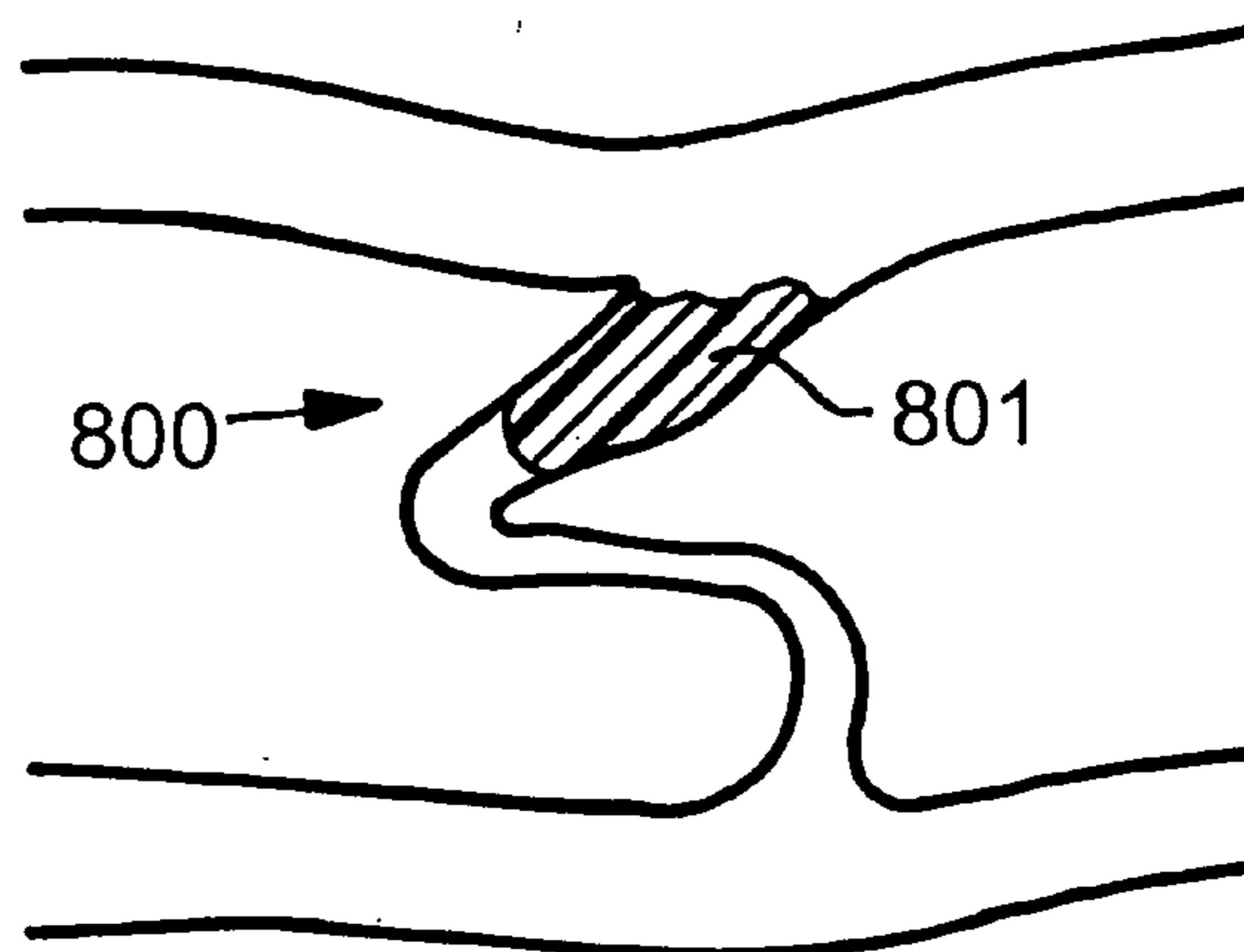

FIG. 8

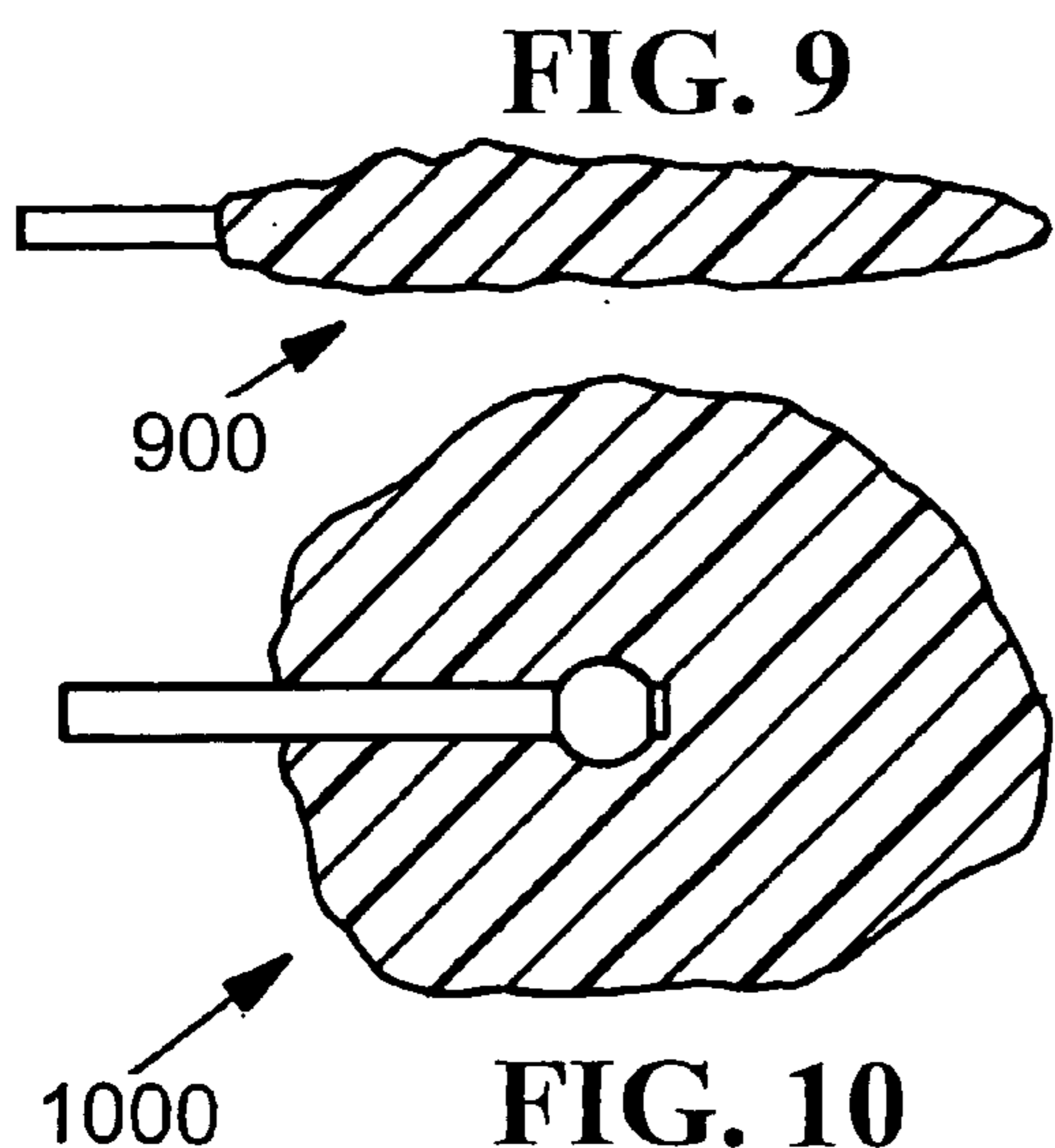

FIG. 9

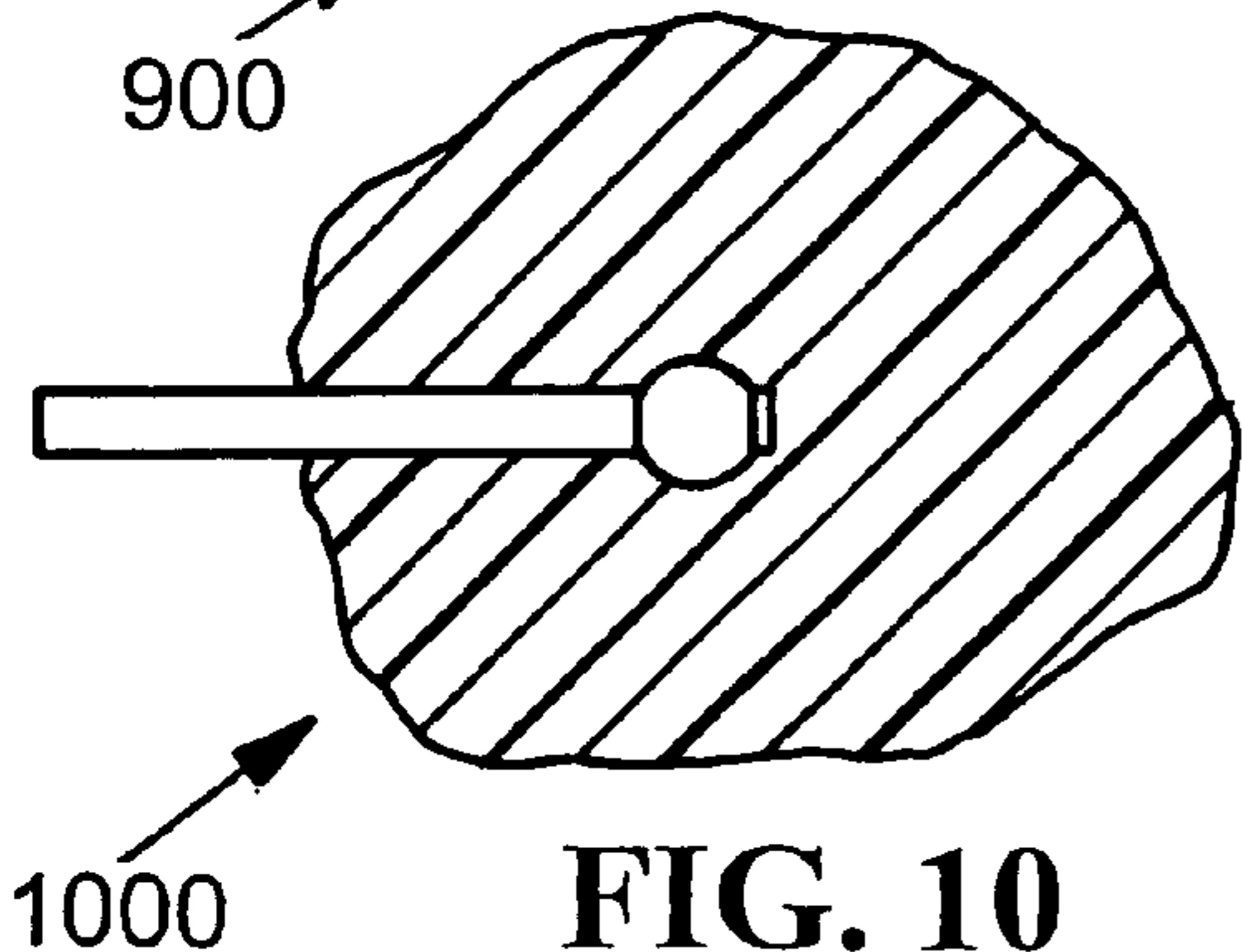

FIG. 10

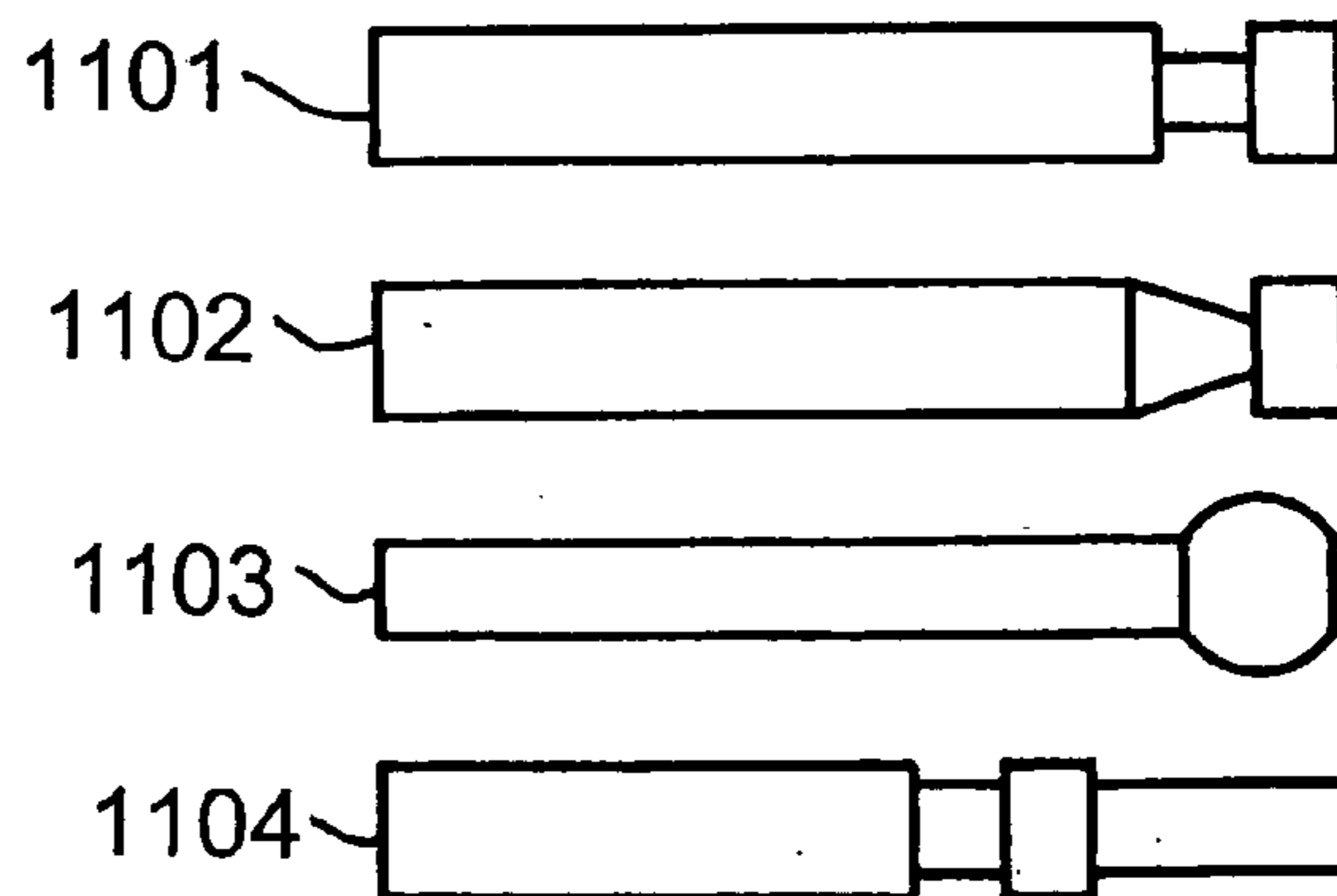
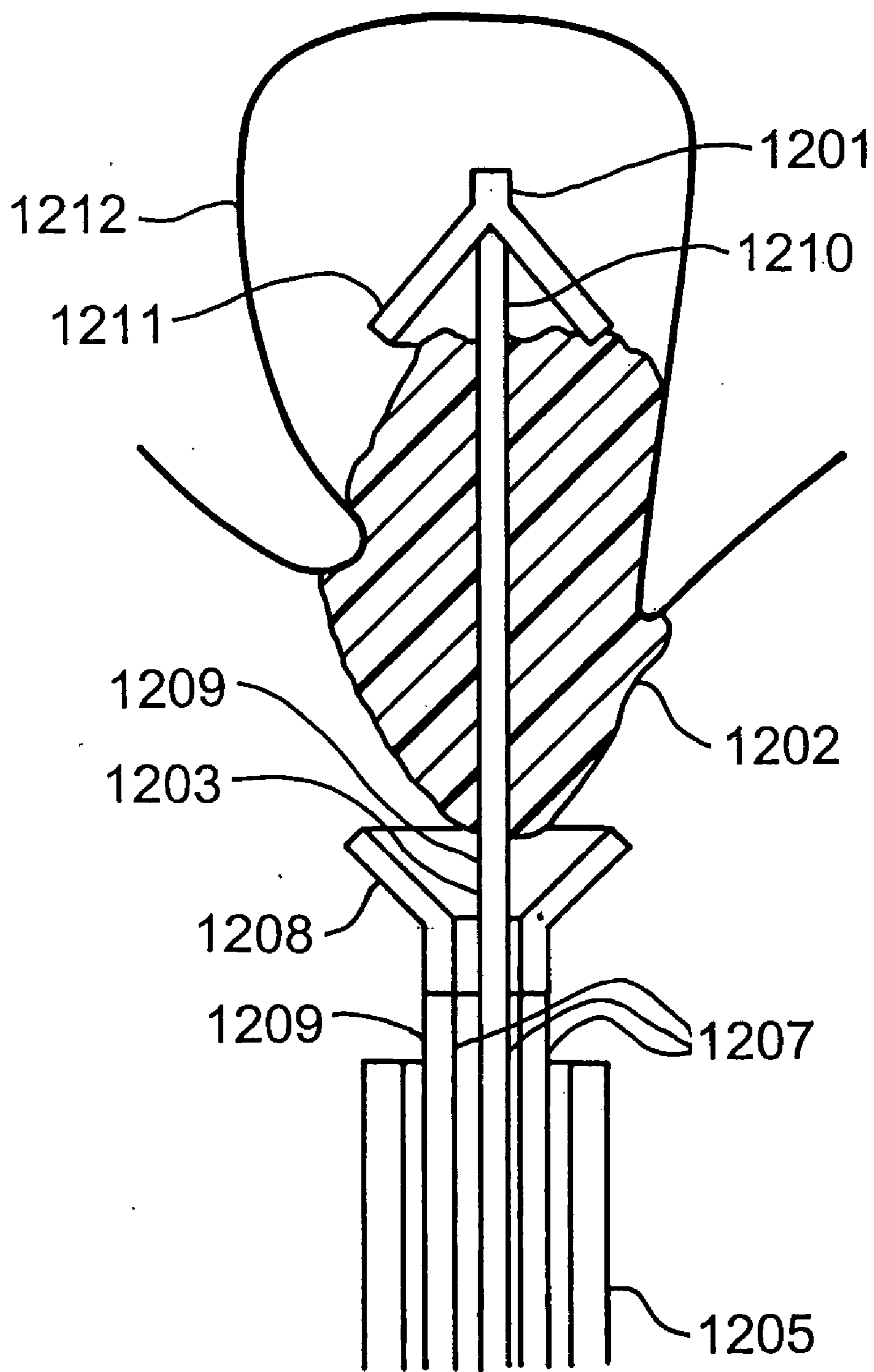

FIG. 11



1200

FIG. 12

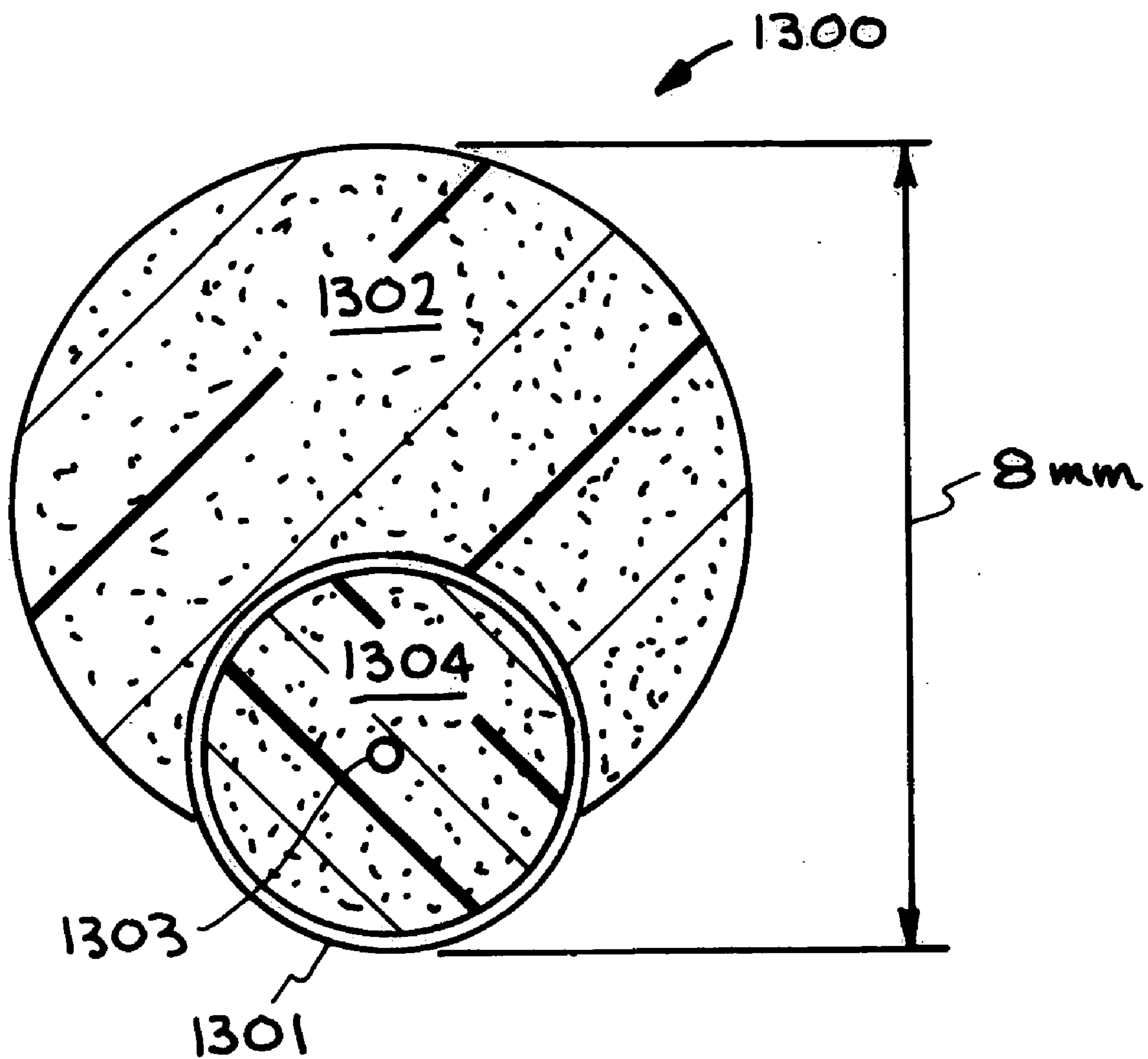

FIG. 13

STENT WITH EXPANDABLE FOAM**CROSS-REFERENCE TO RELATED APPLICATIONS**

[0001] This application is a Continuation-in-Part of U.S. patent application Ser. No. 10/801,355 filed Mar. 15, 2004 by Thomas S. Wilson and Duncan J. Maitland and titled, "Shape Memory Polymer Foams for Endovascular Therapies." U.S. patent application Ser. No. 10/801,355 filed Mar. 15, 2004 by Thomas S. Wilson and Duncan J. Maitland and titled, "Shape Memory Polymer Foams for Endovascular Therapies" is incorporated herein by this reference.

[0002] The United States Government has rights in this invention pursuant to Contract No. W-7405-ENG-48 between the United States Department of Energy and the University of California for the operation of Lawrence Livermore National Laboratory.

BACKGROUND

[0003] 1. Field of Endeavor

[0004] The present invention relates to endovascular therapies and shape memory polymer foams for endovascular therapies and more particularly to a shape memory polymer stent.

[0005] 2. State of Technology

[0006] United States Patent Application 2003/0144695 by James, F. McGuckin and Richard T. Briganti, published Jul. 31, 2003, and United States Patent Application 2003/0009180 by Peter W. J. Hinchliffe, James, F. McGuckin, Richard T. Briganti, and Walter H. Peters, published Jan. 9, 2003, for a vascular hole closure device provides the following state of the technology information, "During certain types of vascular surgery, catheters are inserted through an incision in the skin and underlying tissue to access the femoral artery in the patient's leg. The catheter is then inserted through the access opening made in the wall of the femoral artery and guided through the artery to the desired site to perform surgical procedures such as angioplasty or plaque removal. After the surgical procedure is completed and the catheter is removed from the patient, the access hole must be closed. This is quite difficult not only because of the high blood flow from the artery, but also because there are many layers of tissue that must be penetrated to reach the femoral artery."

[0007] United States Patent Application 2002/0133193 published Sep. 19, 2002, and U.S. Pat. No. 6,391,048 issued May 21, 2002, to Richard S. Ginn and W. Martin Belef, for an integrated vascular device with puncture site closure component and sealant and methods of use provides the following state of the technology information, "Catheterization and interventional procedures, such as angioplasty and stenting, generally are performed by inserting a hollow needle through a patient's skin and muscle tissue into the vascular system. A guide wire then is passed through the needle lumen into the patient's blood vessel. The needle is removed and an introducer sheath is advanced over the guide wire into the vessel. A catheter typically is passed through the lumen of the introducer sheath and advanced over the guide wire into position for a medical procedure. The introducer sheath therefore facilitates insertion of various devices into the vessel while minimizing trauma to the

vessel wall and minimizing blood loss during a procedure. Upon completion of the medical procedure, the catheter and introducer sheath are removed, leaving a puncture site in the vessel. Commonly, external pressure is applied until clotting and wound sealing occurs. However, this procedure is time consuming and expensive, requiring as much as an hour of a physician's or nurse's time, is uncomfortable for the patient, and requires that the patient be immobilized in the operating room, cathlab, or holding area. Furthermore, a risk of hematoma exists from bleeding prior to hemostasis."

[0008] U.S. Pat. No. 6,174,322 issued Jan. 16, 2001 to Bernhard Schneidt for an Occlusion device for the closure of a physical anomaly such as a vascular aperture or an aperture in a septum provides the following state of the technology information, "The human circulatory system is comprised of a cardiovascular circulation and pulmonary circulation. In the embryonic phase of the development of a human being, the two circulatory systems are joined by the ductus arteriosus. The ductus connects the aorta (systemic circulation) with the pulmonary artery (pulmonary circulation). In the normal development of an infant, this ductus closes after birth. In pathological development, the ductus may not close so that the two circulatory systems remain connected even after birth. This can reduce the life expectancy of the infant. Closure of the ductus by means of a surgical procedure is well-known. However, this procedure is very cost-intensive and is connected with a risk for the patient. Closure of the ductus by means of an IVALON.RTM. (polyvinyl alcohol) foam plug (Porstmann method) is also well-known. In this case, a guide rail is introduced via a femoral vein into the aorta, through the ductus into the pulmonary artery and from there through the right ventricle and the right atrium and finally to the outside again via the opposite femoral vein. The ductus plug is then pushed into the ductus where it is 'jammed in place.' Owing to the high pressure differential 1 between the aorta and pulmonary artery, high demands are placed on the fixation of the ductus plug within the ductus."

[0009] United States Published Patent Application No. 2005/0267570 by John H. Shaddock for endovascular occlusion devices and methods of use, published Dec. 1, 2005, provides the state of the technology information set out below.

[0010] The Published Patent Application No. 2005/0267570 "invention relates to an implant body that includes a shape-transformable polymeric structure for self-deployment within vasculature, and can be an open-cell shape memory polymer in the form of a microfabricated structure or a foam and also can be carried about a skeletal stent to provide stress-free means for occluding an AVM without applying additional pressures to the distended walls of an AVM."

[0011] "Numerous vascular disorders, as well as non-vascular disorders, are treated by occluding blood flow through a region of the patient's vasculature. For example, aneurysms, fistulas, varicose veins and the like are treated with vessel occluding devices. Tumors and the like are also treated with endovascular embolic elements to terminate blood flow. Several procedures are described below."

[0012] "An intracranial aneurysm is a localized distension or dilation of an artery due to a weakening of the vessel wall. In a typical example, a berry aneurysm is a small bulging, quasi-spherical distension of an artery that occurs in the

cerebral vasculature. The distension of the vessel wall is referred to as an aneurysm sac, and may result from congenital defects or from preexisting conditions such as hypertensive vascular disease and atherosclerosis, or from head trauma. Up to 2% to 5% of the U.S. population is believed to harbor an intracranial aneurysm. It has been reported that there are between 25,000 and 30,000 annual intracranial aneurysm ruptures in North America, with a resultant combined morbidity and mortality rate of about 50%. (See Weir B., *Intracranial aneurysms and subarachnoid hemorrhage: an overview*, in Wilkins R. H., Ed. *Neurosurgery*, New York: McGraw-Hill, Vol. 2, pp 1308-1329 (1985)).”

[0013] “Rupture of a cerebral aneurysm is dangerous and typically results in bleeding in the brain or in the area surrounding the brain, leading to an intracranial hematoma. Other conditions following rupture include hydrocephalus (excessive accumulation of cerebrospinal fluid) and vasospasm (spasm of the blood vessels).”

[0014] “Several methods of treating intracranial aneurysms are known including open surgeries and endovascular procedures. In an open craniotomy, a clip is placed at the base of the aneurysm. Long-term studies have established typical morbidity, mortality, and recurrence rates.”

[0015] “The least invasive approach for treating intracranial aneurysms is an endovascular method—which consists of a reconstructive procedure in which the parent vessel is preserved. Luessenhop developed the first catheter-based treatment of an intracranial aneurysm (see Luessenhop A. J., Velasquez A. C., *Observations on the tolerance of intracranial arteries to catheterization*, *J. Neurosurg.* 21:85-91 (1964)). At that time, technology was not yet developed for successful outcomes. Serbinenko and others deployed latex balloons in intracranial aneurysms (see Serbinenko, F. A., *Balloon catheterization and occlusion of major cerebral vessels*, *J. Neurosurg.* 41:125-145 (1974)) with mixed results.”

[0016] “More recently, Guglielmi and colleagues succeeded in developing microcatheter-based systems (GDC or Guglielmi detachable coil systems) that deliver very soft platinum microcoils into an aneurysm to mechanically occlude the aneurysm sac. After the position of the microcoil is believed to be stable within the aneurysm sac, the coil is detached from the guidewire by means of an electrolytic detachment mechanism and permanently deployed in the aneurysm. If coil placement is unstable, the coil can be withdrawn, re-positioned or changed-out to a coil having different dimensions. Several coils are often packed within an aneurysm sac. Various types of such embolic coils are disclosed in the following U.S. patents by Guglielmi and others: U.S. Pat. Nos. 5,122,136; 5,354,295; 5,843,118; 5,403,194; 5,964,797; 5,935,145; 5,976,162 and 6,001,092.”

[0017] “Microcatheter technology has developed to permit very precise intravascular navigation, with trackable, flexible, and pushable microcatheters that typically allow safe engagement of the lumen of the aneurysm. However, while the practice of implanting embolic coils has advanced technologically, there still are drawbacks in the use of GDC-type coils. One complication following embolic coil implantation is subsequent recanalization and thromboembolic events. These conditions are somewhat related, and typically occur when the deployed coil(s) do not sufficiently mechanically occlude the volume of the aneurysm sac to cause complete

occlusion. Recanalization, or renewed blood flow through the aneurysm sac, can cause expansion of the sac or migration of emboli from the aneurysm. Recanalization can occur after an implantation of a GDC coil if the coil does not form a sufficiently complete embolus in the targeted aneurysm. After the initial intervention, the body’s response to the foreign material within the vasculature causes platelet activation etc., resulting in occlusive material to build up about the embolic coil. After an extended period of time, the build-up of occlusive material about the foreign body will cease. If spaces between the coils and occlusive material are too large, blood flow can course through these spaces thus recanalizing a portion of the thin wall sac. The blood flow also can carry emboli from the occlusive material downstream resulting in serious complications.”

[0018] “Alternative treatments include endovascular occlusion of the aneurysm with a liquid polymer that can polymerize and harden rapidly after being deployed to occlude the aneurysm. Wide neck aneurysms make it difficult to maintain embolic or occlusive materials within the aneurysmal sac—particularly liquid embolic materials. Such embolic materials can dislocate to the parent vessel and poses a high risk of occluding the parent vessel.”

[0019] “Another approach in the prior art is to provide an aneurysm liner of a woven or braided polymeric material such as polypropylene, polyester, urethane, teflon, etc. These mesh materials are difficult to use in treating larger aneurysms, since the materials cannot be compacted into a small diameter catheter.”

[0020] “Any method of endovascular occlusion with packing materials risks overfilling the sac and also the risk of agent migration into the parent vessel. Any overfill of the sac also will cause additional unwanted pressure within the aneurysm.”

[0021] “Another past method for occluding aneurysm sac used an elastic, expandable balloon member or liner that was introduced into the aneurysm and thereafter detached from the catheter. Such balloon implants are not likely to conform to the contours of an aneurysm and thus allow blood canalization about the balloon surface. A balloon also can cause undesired additional pressure on the aneurysm wall if oversized. The deployment and implantation of a balloon that carries stresses that may be released in uncontrollable directions is highly undesirable. Such balloon treatments have been largely abandoned.”

[0022] “Further, there are some aneurysm types that cannot be treated effectively with an endovascular approach. In such cases, the treatment options then may be limited to direct surgical intervention—which can be highly risky for medically compromised patients, and for patient that have difficult-to-access aneurysms (e.g., defects in the posterior circulation region).”

[0023] “The first type of intracranial aneurysm that cannot be treated effectively via an endovascular approach is a wide-neck aneurysm. In many aneurysms, the shape of the aneurysm sac is shape like a bowler’s hat, for example, in which the neck/dome ratio is about 1:1. For the best chance of success in using an embolic coil, an intracranial aneurysm should have a narrow neck that allows the coils to be contained inside the aneurysmal sac. Such containment means that migration of the coil is less likely, and the

possibility of thromboembolic events is reduced. To promote coil stability in wide-neck aneurysms, surgeons have attempted to temporarily reduce the size of the aneurysm neck by dilating a non-detachable balloon during coil deployment thereby allowing the coils to engage the walls of the sac while the neck is blocked. Another type of aneurysm that proves difficult to occlude with embolic coils is a fusiform aneurysm that bulges a large portion of the vessel lumen. Yet another type of aneurysm that responds poorly to endosaccular coiling is a giant aneurysm. In these cases, the recanalization rates remain high, the risk for thromboembolic phenomena is high, and the mass effect persists which related to the lack of volume reduction over time. The treatment of abdominal aortic aneurysms also would benefit from new implant systems that will better engage the vessel wall and occlude the distended vessel wall.”

[0024] “What is needed, in particular, are vaso-occlusive systems and techniques that are reliable and self-deploying for many types of vascular disorders, for example to occlude varicose veins. In particular, improved systems are needed for endovascular treatment of bifurcation aneurysms, wide-neck aneurysms, fusiform aneurysms and giant aneurysms that can provide acceptable outcomes.”

[0025] United States Published Patent Application No. 2005/0267570 by John H. Shaddock for endovascular occlusion devices and methods of use, published Dec. 1, 2005, is incorporated herein by this reference.

SUMMARY

[0026] Features and advantages of the present invention will become apparent from the following description. Applicants are providing this description, which includes drawings and examples of specific embodiments, to give a broad representation of the invention. Various changes and modifications within the spirit and scope of the invention will become apparent to those skilled in the art from this description and by practice of the invention. The scope of the invention is not intended to be limited to the particular forms disclosed and the invention covers all modifications, equivalents, and alternatives falling within the spirit and scope of the invention as defined by the claims.

[0027] The present invention provides a system for occluding a physical anomaly. One embodiment of the present invention comprises a shape memory material body wherein the shape memory material body fits within the physical anomaly occluding the physical anomaly. The shape memory material body has a primary shape for occluding the physical anomaly and a secondary shape for being positioned in the physical anomaly. In one embodiment, the shape memory material body comprises a shape memory polymer. In another embodiment, the shape memory material body comprises a shape memory polymer foam.

[0028] The present invention provides a stent for treating a physical anomaly. The stent includes a skeletal support structure for expanding in the physical anomaly and a shape memory material coupled to the skeletal support structure. In one embodiment the shape memory material has a first shape that is skeletal and a second shape that is non-skeletal. In one embodiment the second shape is configured to alter blood flow parameters to treat an AVM. In one embodiment the second shape is configured to extend at least in part

outwardly from the skeletal support structure. In one embodiment the skeletal support structure has openings and the second shape is configured to extend within the openings of the skeletal support structure. In one embodiment the shape memory material includes a shape memory polymer. In one embodiment the shape memory material is a fabricated open-cell material.

[0029] The present invention provides an implant body for treating vasculature including a shape memory polymer capable of a first temporary compacted shape for endovascular introduction and a second memory expanded shape for altering blood flow parameters in a targeted region of the vasculature. In one embodiment the shape memory polymer is coupled to struts of an expandable stent. In one embodiment the shape memory polymer has an elongated configuration for occluding a blood vessel. In one embodiment the shape memory polymer comprises a constraint for constraining an interior portion of the implant body. In one embodiment the shape memory polymer is at least one of bioerodible and bioabsorbable.

[0030] The invention is susceptible to modifications and alternative forms. Specific embodiments are shown by way of example. It is to be understood that the invention is not limited to the particular forms disclosed. The invention covers all modifications, equivalents, and alternatives falling within the spirit and scope of the invention as defined by the claims.

BRIEF DESCRIPTION OF THE DRAWINGS

[0031] The accompanying drawings, which are incorporated into and constitute a part of the specification, illustrate specific embodiments of the invention and, together with the general description of the invention given above, and the detailed description of the specific embodiments, serve to explain the principles of the invention.

[0032] FIG. 1 illustrates an embodiment of the present invention that provides a system for occluding a physical anomaly.

[0033] FIG. 2 is another view of the embodiment of the present invention shown in FIG. 1.

[0034] FIG. 3 illustrates an example of SMP foam actuator.

[0035] FIG. 4 illustrates a system for optical heating using optic fibers to transport light energy to the SMP actuator.

[0036] FIG. 5 illustrates an embodiment of a foam device system.

[0037] FIG. 6 illustrates another embodiment of a foam device system.

[0038] FIG. 7 illustrates another embodiment of a foam device system.

[0039] FIG. 8 illustrates another embodiment of a foam device system.

[0040] FIG. 9 shows collapsed SMP foam device.

[0041] FIG. 10 shows an expanded SMP foam device.

[0042] FIG. 11 shows embodiments of the distal ends of guidewires.

[0043] FIG. 12 illustrates another embodiment of the present invention.

[0044] FIG. 13 illustrates a SMP stent-foam device with removable inner foam cylinder and laser light diffuser.

DETAILED DESCRIPTION OF THE INVENTION

[0045] Referring now to the drawings, to the following detailed description, and to incorporated materials, detailed information about the invention is provided including the description of specific embodiments.

[0046] The present invention provides a system for occluding a physical anomaly. Various embodiments are contemplated. For example, one embodiment provides a system for treating an arteriovenous malformation. In this embodiment a shape memory device is transferred into the arteriovenous malformation. The shape memory device is actuated expanding it inside the arteriovenous malformation and occluding the arteriovenous malformation.

[0047] In the general application, a vascular anomaly is treated using the device with the intent of stabilizing the anomaly from further expansion and possible rupture. The device is delivered endovascularly to the site for therapy via a catheter. The catheter may be previously placed using a conventional guidewire or the device may be installed using the guidewire. Once the catheter is placed near the therapeutic site, the device is placed into the anomaly with the guidewire and guided visually by radiology. The device is then held in place and the foam is actuated to expand, filling the anomaly. Once expanded, the foam will stay in place on its own or an additional aid will be used to hold it in place; for example, a diaphragm for the aneurysm or a stent for the AVM. The foam is released from the guidewire or catheter via the expansion process or following actuation by known techniques. The guidewire and/or catheter is then retracted and the therapy is completed. Should there be a misplacement of the foam, retrieval is possible using another shape-memory polymer device or other conventional techniques.

[0048] Shape-memory materials have the useful ability of being formable into a primary shape, being reformable into a stable secondary shape, and then being controllably actuated to recover their primary shape. Both metal alloys and polymeric materials can have shape memory. In the case of metals, the shape-memory effect arises from thermally induced solid phase transformations in which the lattice structure of the atoms changes, resulting in macroscopic changes in modulus and dimensions. In the case of polymeric materials, the primary shape is obtained after processing and fixed by physical structures or chemical crosslinking. The secondary shape is obtained by deforming the material while in an elastomeric state and that shape is fixed in one of several ways including cooling the polymer below a crystalline, liquid crystalline, or glass transition temperature; by inducing additional covalent or ionic crosslinking, etc.

[0049] While in the secondary shape some or all of the polymer chains are perturbed from their equilibrium random walk conformation, having a certain degree of bulk orientation. The oriented chains have a certain potential energy, due to their decreased entropy, which provides the driving force for the shape recovery. However, they do not sponta-

neously recover due to either kinetic effects (if below their lower T_g) or physical restraints (physical or chemical crosslinks). Actuation then occurs for the recovery to the primary shape by removing that restraint, e.g., heating the polymer above its glass transition or melting temperature, removing ionic or covalent crosslinks, etc. Other types of polymers which undergo shape memory behavior due to photon induced conformational transformations, conformational changes (e.g., rod-coil transition) due to changes in chemical environment (pH, ionic strength, etc.), or structural changes due to imposed fields (e.g., electric, magnetic, . . .) may also be used. Both shape memory alloys (SMAs) and shape memory polymers (SMPs) can be used for the shape memory material of the present invention.

[0050] A shape memory material therapeutic device has advantages over existing therapeutic devices of being able to be moved more easily through the catheter to the point of placement. A shape memory material therapeutic can be placed more precisely within the geometry of the vascular disorder, and there is a higher degree of control over the expansion process while the device was being held in the desired position. A shape memory material therapeutic can be controllably expanded while being held in precise placement. A shape memory material therapeutic expands to its secondary shape within a few seconds, which is much faster than current expandable hydrogel based devices. The modulus of the devices can be accurately controlled so that expansion forces are low and no damage is done to areas of the vascular lumen.

[0051] The shape memory material device is expandable from 100% to 10000% by volume. The shape memory material device is actuated by one of several means including electromagnetic energy delivered optically. The shape memory material device is used to occlude part or all of a lumen, aneurysm, arteriovascular malformation, or other physical anomaly.

[0052] The present invention also provides a process for making SMP foams with specific pore structures; geometric shaping of the SMP device to fit specific physiological geometries; the coating of the surface of the SMP to enhance biocompatibility and promote integration into the body; the development of a complete therapeutic device for aneurysm (and AVM) treatment which includes techniques to ensure proper placement and device designs and techniques to remove devices which have been improperly placed.

[0053] Referring now to FIGS. 1 and 2, two figures will be used to describe an embodiment of the present invention that provides a system for occluding a physical anomaly. The embodiment is designated generally by the reference numeral 100. FIGS. 1 and 2 are schematic illustrations of the working end of a system 100 for treating an arteriovenous malformation or aneurysm 102.

[0054] As shown in FIG. 1, a collapsed SMP foam device 105 is connected at the end of a guide wire 104. The SMP foam device 105 is placed inside the aneurysm 102. This is accomplished by delivering the SMP foam device 105 through a catheter 103 using the guide wire 104. The catheter 103 is inserted through the artery 101 to position the SMP foam device 105 in the aneurysm 102.

[0055] Referring now to FIG. 2 the SMP foam device 105 is shown actuated, thereby expanding it inside the aneurysm

102 and occluding the aneurysm **102**. The SMP foam device **105** is expandable from 100% to 10000% in volume. The SMP foam device **105** is actuated by one of several means including electromagnetic energy delivered optically. The SMP foam device **105** is used to occlude part or all of a lumen, aneurysm, or arteriovascular malformation. The expanded SMP foam device **105** is releasing from the end of the guide wire **104**. The guide wire **104** is then retracted through the catheter **103**. The catheter **103** is then retracted from the artery **101**.

[0056] The SMP foam device **105** is made out of “shape memory polymer” (SMP). The SMP is a material which can be formed into a specific “primary” shape, reformed into a “secondary” stable shape, then controllably actuated so that it recovers its primary shape. The SMP device **105** has the structure of an open cell foam with porosity, pore size, and size distributions designed for each individual application.

[0057] The general concept behind the SMP foam device for aneurysm therapy will be summarized with reference to FIGS. **1** and **2**. The device consists of an SMP foam actuator **105** on the distal end, which is connected to the distal end of a catheter **103** or alternatively the distal end of a guide-wire assembly **104**. The catheter **103** or guide wire **104** contains an optic fiber or alternative means to heat or radiate the SMP **105** for actuation. There is a coupling between the SMP foam **105** and the guide wire **103** which can be selectively disengaged. The SMP foam device **105** is made of a suitable biocompatible SMP, is loaded with a radiopaque additive, contains a laser dye suitable for vascular use, and is coated with a thrombogenic material such that upon actuation the large surface of the foam promotes rapid thrombus formation within the geometry of the foam and adhesion of the foam to the aneurysm wall. The foam device **105** can be made in a number of standard geometries for aneurysm, AVM, or vascular anomalies. For each use, a pre-made foam geometry is chosen which best fits the therapeutic need.

[0058] The present invention has uses wherever it is desirable to occlude a physical anomaly. For example, the present invention has use for the closure of an aneurysm for the prevention and/or treatment of a stroke.

[0059] Stroke is a major cause of mortality and the primary cause of long-term disability in the United States. Each year there are an estimated 700,000 occurrences of stroke, from which 150,000 people die and 400,000 are left with a significant deficit. The costs of caring for victims of stroke in the acute phase, for chronic care, and lost productivity amount to an estimated \$40 billion per year. Approximately 20% of strokes are hemorrhagic and result from the rupture of either arteriovenous malformations (AVMs) or aneurysms. For aneurysm/AVM rupture, the incidence of death is about 29%, and an additional 20 to 30% of patients suffer neurologic deficits. Since an estimated 4% of aneurysm/AVMs rupture each year, a significant number of people (up to 3.5 million) have aneurysm/AVMs for years prior to stroke occurrence, indicating significant benefit from early preventative treatment.

[0060] There are three treatment modalities for neurovascular aneurysm/AVMs; namely, standard microsurgery, the introduction of agents which occlude parts or all of the aneurysm/AVM, and radio surgery. At present, the highest success rates are achieved using standard microsurgery in

which the aneurysm/AVM is removed. However, microsurgery involves a great deal of trauma (cutting a hole in the skull), long recovery times, and can't be used for a significant minority of aneurysm/AVMs due to insufficient access or patient refusal. Radiosurgery involves applying a focused beam of radiation to vessel walls, resulting in shrinkage of the aneurysm/AVM. Radiosurgery is limited though to use in aneurysm/AVMs which are relatively small in size and carries with it the risk of damage to surrounding brain tissue.

[0061] An emerging modality is the endovascular introduction of occluding glues or metal coils for aneurysm/AVM stabilization and to promote healing. However, endovascular therapy based on current devices and materials results in cure rates of only 5-10% and carries a 3-5% risk of serious complications; these include adhesion of the catheter to the aneurysm/AVM, glue or solvent toxicity, escape of material creating embolic events downstream from the aneurysm/AVM, and aneurysm/AVM rupture.

[0062] The current FDA-approved endovascular procedure for treating aneurysms is the GDC (Guglielmi Detachable Coil-Target Therapeutics, Fremont, Calif.). The embolic coils are delivered through an interventional guide catheter into the aneurysm. The guide catheter generally enters through the femoral artery and is then negotiated through the cardiovascular into the cerebrovasculature. A typical guide catheter is the Tracker **18** from Target Therapeutics with a 0.018 inch (approximately 450 μm) working channel for delivering therapeutic devices. The tip of the guide catheter is placed in the aneurysm through the neck of the aneurysm using fluoroscopic (x-ray) image guidance. Successive coils are deposited such that they fill the volume of the aneurysm, resulting in reduced/eliminated blood flow in the aneurysm and, in turn, a greatly reduced risk of acute stroke. Once the blood flow in the aneurysm has been stopped, the body generally seals off the aneurysm resulting in complete patient recovery with no risk of hemorrhagic stroke. Therapy utilizing the GDC has a number of limitations including a long procedure time required to place several coils, the large mismatch between the mechanical properties of the coil and the vascular wall, and the possibility of a coil escaping from the aneurysm/AVM and lodging downstream, causing an embolic event.

[0063] SMP actuators are made of any polymeric material that exhibits a shape-memory effect and is suitable for use in this application. This includes:

[0064] Thermoplastic SMPs—thermoplastic polymers are those which can be heated into a melt state in which all prior solid shape memory has been lost, processed into a shape, and solidified. If need be they can be re-heated to their melt state and re-processed a number of times. In thermoplastic SMPs, the shape memory effect generally relates to the material having a multiphase structure in which the different phases have different thermal transitions, which may be due to glass transitions, crystalline melting points, liquid crystal-solid transitions, ionomeric transitions, etc. The primary shape is obtained by processing in the melt state above the highest transition temperature and then cooling to a temperature in which either a hard phase or other physical crosslink is formed to lock in that shape. The secondary shape is obtained by bringing the material to a temperature above its actuation temperature but below its melting temperature, mechanically shaping the material into its second-

ary shape, then cooling it below its actuation temperature. Suitable thermoplastic SMPs include block copolymers (linear di, tri, and multiblocks; alternating; graft), immiscible polymer blends (neat and with coupling agents such as di or tri-block copolymers), semi-crystalline polymers, and linear polymers with ionic groups along the chain or grafted to the chain.

[0065] Thermosetting SMPs—thermosetting polymers are those which are processed into a part and simultaneously chemically crosslinked, so that the part is essentially one macromolecule. They cannot be re-processed by melting. In thermosetting SMPs the primary shape is obtained during the initial processing step involving crosslinking. The secondary shape is obtained by mechanically reshaping the material at a temperature or condition in which the material is in an elastomeric state. This secondary shape is locked in by cooling the material below the actuation temperature, which relates to a transition as described above. Suitable thermosetting SMPs include all of the types of materials described under thermoplastic SMPs but which can also be chemically crosslinked to form the primary shape. In addition, crosslinked homopolymers can also be used as SMPs with the actuation temperature typically being the glass transition temperature of the material.

[0066] Coil-rod transition SMPs are also used for the shape memory material actuator. Some polymers undergo a coil to rod transition in their chain conformation by relatively small changes in their environment, such as solvent changes or changes in the ionic character in an aqueous environment. Similarly, adsorption of electromagnetic radiation of a specific wavelength can cause changes in the conformation of certain polymers, which induces a macroscopic shape response. Both thermoplastic and thermosetting polymers which undergo such rod-coil transitions can be used for this application.

[0067] While all shape memory polymer compositions are suitable for the current invention, the compositions having the following properties are particularly suitable: (1) Transparency—this usually is a characteristic of an SMP which is two phase but with microphase sizes below about 50 microns, an SMP which is single phase and whose primary shape is fixed by covalent or ionic crosslinking, or a multiphase system in which all phases have very similar refractive indices. (2) The lowest transition temperature, used for actuation, is in the range of 20 C to 80 C. (3) The polymer is biocompatible (does not invoke immune response) and biodegradable over a controlled period of time. Biodegradation products should likewise be non-toxic. (4) SMPs which have hysteresis in the modulus temperature curve. This means that the thermal transition from the glassy to the rubbery state in the SMP is higher during heating than it is during cooling, such that following in-vivo actuation the SMP remains in an elastomeric state. The amount of the hysteresis, determined by the shift in the transition temperature as measured by DSC, would be in the range of 5 to 50° C. This shift could be due to melting of crystallinity responsible for the transition, absorption of physiological compounds which act as plasticizers, thermally induced mixing or demixing of the SMP itself, or chemical changes induced during actuation which change the Tg of the material. This property of the SMP would be important for preventing damage to tissue and organs during use. (5) The SMP can be blended with a radiological contrast agent such as barium

sulfate, tantalum oxide, etc. (6) The SMP can be made into a foam by traditional or porogen templating techniques. (7) The surface of the SMP device can be chemically functionalized or alternatively coated to promote the formation of a thrombus within the polymer structure. (8) The SMP can contain a dye suitable for adsorption of electromagnetic radiation with wavelengths in the range of 300 to 1200 nanometers. Dyes with adsorption peaks centered near 800 nm would be particularly suitable.

[0068] The SMP is ideally made into an open cell foam structure with a distribution of pore sizes in the range going from tens of nanometers to ca. 500 microns on the high end. The mean pore size should be in the range of 10 to 50 microns. Such a pore size and size distribution would be optimal for a therapeutic device used to treat aneurysm in the following regards: it would promote the rapid aspiration of blood into the device during expansion, including all components necessary for thrombus formation; it would allow for the making of foam structures with high expansibility (low density); pore size and distribution can be used also to help control the recovery forces imposed by the device on the aneurysm wall during expansion. The expansibility (Final volume/initial volume) of the foams claimed here are in the range of 200 to 20000%, or expansion ratios of 2 to 200.

[0069] Referring now to FIG. 3, an example of SMP foam actuator is illustrated. The SMP foam actuator designated by the reference numeral 300 is shown after being heated to 70 C, compressed, and cooled to room temperature under compression. The same SMP foam actuator designated by the reference numeral 300' is shown after 5 seconds at 70 C followed by cooling to room temperature. The SMP foam actuator 300/300' is an open cell foam composed of a polyurethane SMP. The foam is made using a 10% solution of SMP in DMSO impregnated into a pressed cube of sucrose crystals, followed by solvent removal, extraction of the sucrose with water, then dried. The SMP foam actuator can be made by a variety of techniques including: (1) Porogen templating, (2) Chemical blowing, (3) Solvent (physical) blowing, (4) Gas blowing, (5) Freeze drying SMP solutions, (6) High inverse phase emulsion process, or any combination of the above techniques.

[0070] The SMP actuator can be expanded by various mechanisms for actuation based on movement through a thermal transition. The mechanisms include optical heating, convective heating using a heat transfer medium, electrical resistance heating, inductive heating, x-ray induced reaction, and by exposure to biologically compatible solvents which can induce a change in the SMP thermal transitions when absorbed.

[0071] Referring now to FIG. 4, a system for optical heating using optic fibers to transport light energy to the SMP actuator as shown schematically. The system is designated generally by the reference numeral 400. FIG. 4 is a schematic overview of an ischemic stroke treatment system 400. Laser light from laser 401 is transmitted through a multimode optical fiber 402, a fiber coupler 403, an extension fiber 404 that enters the sterile surgical field, and a fiber pusher 405 with the SMP actuator 406 at the distal tip of the central tube and inner catheter 410. Separate fibers are used to actuate the central tube tip and the inner catheter tip for independent control. A small amount of laser light is

reflected from the fiber-coil interface back through the coupler **403** into the photodetector **407**. Source fluctuations may be monitored by the source photodetector **408**. As the laser light heats the SMP **406** in the distal tip of the catheter, the umbrella deploys. As an optional design feature, detection of the actuation can be fed back to the operator (or computer) **409**. The SMP **406** movement causes the reflected signal to decrease. The changes in the reflected signal can be used to control the driving current of the laser **401** or to alert an operator of the status of the actuator **406** (e.g., open or closed). The light can be absorbed by a suitable dye, which is incorporated into the SMP actuator uniformly, or in a gradient engineered to provide for even heating throughout the actuator geometry.

[0072] Optical heating may also be accomplished by placing the light absorbing dye in an elastomeric coating on the surfaces of the SMP actuator or in an aqueous media which is in contact with the SMP device. Optical heating is preferable from the standpoint that most of the energy applied is used to heat the SMP, minimizing thermal damage to the blood or tissue.

[0073] Convective heating may also be used for actuation of the SMP end by pumping a heated saline solution through the interstitial space between the inside of the guide catheter and the outside of the second catheter with the SMP actuator end. This approach can be combined with fiber-optic heating to boost the temperature of the saline to a needed level should cooling during transport through the catheter be a problem.

[0074] Inductive heating can be accomplished by filling the SMP with microparticles or nanoparticles of a material which can selectively absorb RF radiation, converting it to heat. By having an even distribution of particles in the SMP actuator and applying a uniform field the SMP can be quickly and evenly heated for actuation.

[0075] An SMP foam occlusion device as described above has the properties of being capable of catheter delivery, be easily and accurately positioned, have rapid and controlled expansion from a small initial size to a size and shape approximately that of the aneurysm or arteriovenous malformation (AVM) being stabilized, be made of biocompatible materials, stimulate the bodies own repair mechanisms for the aneurysm or AVM, and disappear without causing further injury as the vascular lumen repairs itself. The high expansibility of the device allows for treatment with a single or relatively small number of devices versus the current need for many (tens) coil type devices. While the SMP foam has fairly low modulus, the strength of the foam is sufficient to prevent it from being removed from the aneurysm due to blood flow in the adjoining lumen. The system of the present invention also allows for the removal of the SMP foam device via the delivery catheter should there be a problem with placement.

[0076] Referring now to FIGS. **5**, **6**, **7**, and **8**, different foam device systems are illustrated. The systems are designated generally by the reference numerals **500**, **600**, **700**, and **800** in the four figures. In FIGS. **5** and **6** the SMP foam systems **500** and **600** are used to occlude and prevent further expansion of aneurysm **501**. In FIG. **7** the SMP foam system **700** is used to occlude and prevent further expansion of arteriovenous malformation **701**. In FIG. **8** the SMP foam

system **800** is used to occlude and prevent further expansion of an enlarged capillary **801** shunting blood flow between arteries and veins.

[0077] The therapeutic devices **500**, **600**, **700**, and **800** are delivered endovascularly via catheter. The primary method for placement of the devices **500**, **600**, **700**, and **800** is via radiology. The devices **500**, **600**, **700**, and **800** have sufficient radio-contrast through the use of radiopaque fillers or due to other aspects of composition. Other tools for determining placement include fiber-optic based imaging technologies such as OCT, etc.

[0078] The SMP foam devices **500**, **600**, **700**, and **800** are released from the catheter or guide wire either during actuation due to expansion away from an interlocking geometry or following expansion through a second actuation event. The foam is mechanically attached to the guide wire or catheter and upon expansion, is released from the mechanical interlock. The collapsed device is shown in the expanded foam and various geometries that may be useful for the mechanical interlock. Other types of release mechanisms can be used for the SMP foam device based on the change in geometry of SMP and SMA devices on the catheter tip, to dissolution of a bonding material, to galvanic erosion of a connector, etc.

[0079] Once the SMP foam device has been placed, it is important that it stays in position and does not get pushed out into the channel with the desired blood flow pattern. There are a number of ways that the devices **500**, **600**, **700**, and **800** can be held in place. First, the device can hold itself in place when it is situated in an aneurysm in which the aneurysm cavity is larger than the aneurysm opening. Upon thrombosis within the foam, it will be very difficult for the foam device to be pushed out. A second method for holding the device into that cavity is through the action of a diaphragm or other geometry which covers the aneurysm opening. In the case of the occlusion of a vascular shunt, the foam geometry is made longer and tends to hold it in place both by the tapered geometry of the vascular lumen and the hydrostatic pressure of the blood flow. Thrombosis of the blood within the foam will also help to hold it in place. A secondary device such as an SMP stent or coil structure can also be used to provide additional support.

[0080] Referring now to FIG. **9**, a collapsed device **900** is shown. The collapsed SMP foam device **900** may be connected at the end of a guide wire or other system for delivery. The SMP foam device **900** is placed in the desired location. For example, this is accomplished by delivering the SMP foam device **900** through a catheter using a guide wire.

[0081] Referring now to FIG. **10**, an expanded foam (actuated) device **100** is shown. For example the device **1000** can be expanding it inside the aneurysm and occlude the aneurysm. The SMP foam device **1000** is expandable from 100% to 10000%. The SMP foam device **1000** is actuated by one of several means including electromagnetic energy delivered optically. The SMP foam device **1000** can be used to occlude part or all of a lumen, aneurysm, or arteriovascular malformation. The expanded SMP foam device **1000** can be releasing from the end of a guide wire. The guide wire can then be retracted through the catheter. The catheter can then be retracted from the artery.

[0082] Referring now to FIG. **11**, examples of guidewires having various geometries **1101**, **1102**, **1103**, and **1104** are

shown that may be useful for the mechanical interlock connecting the SMP foam to the end of a guide wire. The guidewire **1101** has a reduced diameter section near its distal end. The guidewire **1102** has a conical reduced diameter section near its distal end. The guidewire **1103** has a spherical expanded diameter section near its distal end. The guidewire **1104** has a reduced diameter section and an expanded diameter section near its distal end.

[0083] Referring now to FIG. 12, another embodiment of the present invention is shown for retrieving a misplaced foam device. This embodiment is designated generally by the reference numeral **1200**. The guidewire **1209** that is normally used for delivering a SMP foam device includes a second SMP (or other type) device **1201**. The second SMP device **1201** can be separately expanded.

[0084] The various components of the system **1200** include a delivery catheter **1205**, an inner catheter **1206** containing optical fibers **1207** and with a flaring SMP distal tip **1208**, a guide wire **1209** with optic fiber **1210**, and a SMP gripper/release device **1211**. The misplaced SMP foam device **1202** is shown located in an aneurysm **1212**. The secondary SMP device **1201** is at the distal end of the guidewire **1209** and can catch the misplaced foam **1202** and draw it back toward the catheter **1205**. An alternate device would allow the SMP foam to be gripped on each side and stretched to form a thinner cylinder for withdrawal.

[0085] In operation, the guidewire **1209** is extended through the misplaced SMP foam. The second SMP device **1201** is expanded resulting in the misplaced foam **1202** being gripped between the distal end **1203** of the guidewire **1209** and the distal end of the second SMP expandable device **1201**. The foam **1202** is then drawn back into the delivery catheter **1205** or simply removed by removal of the entire assembly while being gripped. The system **1200** facilitates withdrawal of a misplaced device.

[0086] Referring now to FIG. 13, a SMP stent-foam device with removable inner foam cylinder and laser light diffuser is illustrated. The SMP stent-foam device is designated generally by the reference numeral **1300**. The SMP stent-foam device **1300** provides a stent for treating a physical anomaly. The stent includes a skeletal support structure for expanding in the physical anomaly and a shape memory material coupled to the skeletal support structure. In one embodiment the shape memory material has a first shape that is skeletal and a second shape that is non-skeletal. In one embodiment the second shape is configured to alter blood flow parameters to treat an AVM. In one embodiment the second shape is configured to extend at least in part outwardly from the skeletal support structure. In one embodiment the skeletal support structure has openings and the second shape is configured to extend within the openings of the skeletal support structure. In one embodiment the shape memory material includes a shape memory polymer. In one embodiment the shape memory material is a fabricated open-cell material.

[0087] The SMP stent-foam device **1300** provides an implant body for treating vasculature including a shape memory polymer capable of a first temporary compacted shape for endovascular introduction and a second memory expanded shape for altering blood flow parameters in a targeted region of the vasculature. In one embodiment the shape memory polymer is coupled to struts of an expandable

stent. In one embodiment the shape memory polymer has an elongated configuration for occluding a blood vessel. In one embodiment the shape memory polymer comprises a constraint for constraining an interior portion of the implant body. In one embodiment the shape memory polymer is at least one of bioerodible and bioabsorbable.

[0088] A prototype of the SMP stent-foam device **1300** consisting of a stent augmented with expandable foam, both made from shape memory polymer, was fabricated and deployed in an in vitro model. Visual observation indicated that the foam achieved embolization of the aneurysm while the stent maintained an open lumen in the parent artery. The SMP stent-foam device is a tool for treatment of non-necked fusiform aneurysms, as well as an alternative to stent- and balloon-assisted coil embolization of wide-necked aneurysms.

[0089] A cerebral aneurysm is a localized dilatation consisting of a bulge in the weakened artery wall that is prone to rupture. The risk of rupture increases with increasing aneurysm size and treatment is not recommended for small unruptured aneurysms (<7 mm in diameter). Ruptured aneurysms result in hemorrhage which can lead to severe neurological deficit or death. One characteristic used to determine the method of treatment is the size of the neck formed at the base of the aneurysm. Saccular aneurysms with a relatively narrow neck are generally treated endovascularly by coil embolization, a procedure in which the aneurysm lumen is filled with detachable embolic coils delivered using a microcatheter. The deployed coils shield the vulnerable aneurysm wall from blood flow to prevent rupture. Wide-necked aneurysms are more difficult to treat, requiring staged treatment methods such as stent-assisted coil embolization or balloon remodeling, in which a stent or balloon is used to prevent migration of the embolic coils into the parent artery. The stent-assisted technique involves endovascular placement of a stent in the parent artery across the aneurysm neck followed by delivery of embolic coils through the stent interstices into the aneurysm lumen. The balloon remodeling technique consists of temporary inflation of a balloon at the end of a microcatheter in the parent artery across the aneurysm neck during embolic coil delivery; since only one coil can be delivered at a time, the balloon is periodically deflated for delivery of successive coils and then removed once the final coil is delivered.

[0090] The SMP device **1300** is comprised of two main components: a SMP stent **1301** and a SMP embolic foam **1302** attached to the outside of the stent **1301**. The embolic foam component **1302** fills the aneurysm lumen while the stent **1301** maintains a patent flow channel in the parent artery. The SMP device **1300** includes a diffuser **1303** and an inner foam cylinder **1304**.

[0091] SMP has the unique ability to recover a primary (memorized) shape via a thermal actuation mechanism. When sufficiently below its characteristic soft phase glass transition temperature (T_g), the glassy (elastic modulus $\sim 10^9$ Pa) SMP can maintain a secondary shape that is different than its original primary shape. The secondary shape is obtained by reforming the SMP while heated above T_g (but below the hard phase glass transition temperature to avoid setting a new primary shape) and then cooling to stabilize the new shape. As the temperature increases to and beyond T_g , the modulus falls and the rubbery (elastic modulus $\sim 10^6$

to 10^7 Pa) SMP transforms back to its primary shape. The transition from the secondary to the primary shape is not sharp; the modulus falls gradually over a span of $\sim 30^\circ$ C. with the nominal T_g approximately centered in the decline. The low modulus of the SMP results in a flexible, compliant structure during actuation. Upon cooling, the original modulus is nearly completely recovered and the primary shape is stabilized.

[0092] Fabrication of the stent component began by dip coating a stainless steel pin (4 mm diameter by 45 mm long) with a solution of thermoplastic MM-5520 SMP (DiAPLEX Company Ltd., a subsidiary of Mitsubishi Heavy Industries Ltd.) and laser-absorbing dye (Epolight 4121, Epolin, Inc.) dissolved in tetrahydrofuran to a final thickness of ~ 175 μm . The SMP tube was then excimer laser cut to impart a mesh pattern and removed from the pin. The nominal T_g of the SMP was 55° C. though the actual T_g of the finished stent was likely lower due to exposure to moisture in the air as well as residual solvent. Based on spectrophotometry of thin samples cast from thermosetting MP-5510 SMP (DiAPLEX Company Ltd.) doped with various dye concentrations from 0 to 5200 ppm (by weight), the absorption coefficient of the dye-doped SMP stent (~ 2000 ppm dye) was estimated to be ~ 24 cm^{-1} at 810 nm, which corresponds to a $1/e$ light penetration depth (distance at which the light intensity drops to 37%) of 417 μm . The dependence of absorption on dye concentration was assumed to be the same for both the thermoplastic and thermosetting materials based on their similar chemical structures. The measured difference in absorption at 810 nm between the two materials without dye was taken into account in the estimate.

[0093] The foam was based on SMP formulated in-house which is chemically comprised of hexamethylene diisocyanate (HDI), N,N,N',N'-tetrakis(2-hydroxypropyl)ethylene-diamine (HPED), and triethanolamine (TEA). As with the stent, dye (Epolight 4121) was added during processing to aid laser light absorption. The resulting foam had a density of 0.020 g/cm^3 , was predominantly open cell (cell size ~ 200 μm), and had a calculated volumetric void fraction of 98.4%, which allows for a theoretical volume expansibility from a fully condensed state of 60 times. The foam T_g was $\sim 40^\circ$ C. as measured using a differential scanning calorimeter (Pyris Diamond DSC, PerkinElmer Instruments). The T_g can be tailored from approximately 30 to 86° C. by adjusting the relative amounts of HDI, HPED, and TEA. The dye concentration was ~ 900 ppm, corresponding to an absorption coefficient of ~ 11 cm^{-1} and a $1/e$ penetration depth of ~ 900 μm [9]. The foam was machined on a rapid prototyping mill (MDX-650, Roland DGA Corp.) into an ellipsoid with a channel for the SMP stent and then bonded to the stent using a thermosetting polyurethane adhesive.

[0094] An optical fiber tipped with a cylindrical light diffuser (300 μm diameter by 2 cm long) was made in-house and coupled to an 810 nm continuous-wave diode laser (Model UM7800/100/20, Unique Mode) for photothermal actuation of the SMP stent-foam device. The cylindrical diffusing tip was fabricated by casting an SMP formulation over the distal end of a 100 μm core diameter silica optical fiber (FIP100110125, Polymicro Technologies, LLC) using a teflon tube as the casting mold. The surface of the cured SMP cylinder was then abraded using a media blaster loaded with sodium bicarbonate powder to enable light diffusion.

Approximately 60% of the incident laser light was diffused radially outward with the remaining light exiting from the distal end of the diffuser.

[0095] The device was prepared for deployment by incorporating the laser light diffuser followed by collapsing the device for delivery through a guiding catheter. A separate SMP foam cylinder (4 mm in diameter, cut from foam stock using a biopsy punch) was positioned over the laser light diffuser such that the diffuser was coaxial with the foam cylinder. In clinical use, the foam cylinder would be permanently attached to the diffuser to facilitate its removal after deployment. The diffuser/foam cylinder assembly was then inserted into the stent lumen. This inner foam was incorporated to perform three functions: 1) center the diffuser in the stent lumen during expansion, 2) reduce convective cooling of the stent during photothermal actuation, and 3) increase laser light scattering to improve the diffusion uniformity. Finally, the stent-foam device, with the diffuser/foam cylinder inside, was then collapsed using a crimping machine (Balloon Wrapping Fixture Model W8FH, Interface Associates, Inc.) from 8 mm (at the foam apex) down to 2 mm (smaller diameters are possible depending on the amount of material and stent design). The machine consists of eight radially arranged blades which form a cylindrical cavity; as the blades move inward, the cavity diameter decreases. The blades were heated to 93° C. during the collapse, and then cooled to room temperature before the collapsed device was removed.

[0096] A 9.0F guide catheter was inserted into the parent artery of a model of a basilar fusiform aneurysm made from polydimethylsiloxane (PDMS), a silicone elastomer. The model was partially submerged in 23° C. water to keep the aneurysm and parent artery filled with water during device deployment (zero flow). Water near room temperature instead of body temperature was used to fill the model to provide some degree of inhibition of photothermal actuation in the absence of physiologic convective cooling due to blood flow, with the understanding that convection is a much more effective cooling means and would provide a much greater degree of inhibition. The collapsed device was then delivered through the catheter into the aneurysm.

[0097] Because of the broad glass transition, the SMP stent-foam device began to expand spontaneously in the 23° C. water-filled aneurysm prior to turning on the laser; within several seconds, nearly complete expansion was achieved. The laser output power was then gradually stepped up to ~ 3 W (actual power delivered radially outward from the diffuser was less than 2 W) over the next several seconds to further heat the device and finish the expansion. The SMP diffuser was withdrawn and the inner foam cylinder was removed, leaving the deployed SMP stent-foam device in place filling the aneurysm while maintaining an open lumen in the parent vessel.

[0098] While the invention may be susceptible to various modifications and alternative forms, specific embodiments have been shown by way of example in the drawings and have been described in detail herein. However, it should be understood that the invention is not intended to be limited to the particular forms disclosed. Rather, the invention is to cover all modifications, equivalents, and alternatives falling within the spirit and scope of the invention as defined by the following appended claims.

The invention claimed is:

1. A stent for treating a physical anomaly comprising:
a skeletal support structure for expanding in the a physical anomaly, and a shape memory material coupled to said skeletal support structure.
2. The stent of claim 1 wherein said shape memory material has a first shape that is skeletal and a second shape that is non-skeletal.
3. The stent of claim 2 wherein said second shape is configured to alter blood flow parameters to treat an AVM.
4. The stent of claim 2 wherein said second shape is configured to alter blood flow parameters to treat an aneurysm.
5. The stent of claim 2 wherein said second shape is configured to alter blood flow parameters to treat a necked aneurysm.
6. The stent of claim 2 wherein said second shape is configured to alter blood flow parameters to treat a wide-necked aneurysm.
7. The stent of claim 2 wherein said second shape is configured to alter blood flow parameters to treat a fusiform aneurysm.
8. The stent of claim 2 wherein said second shape is configured to extend at least in part outwardly from said skeletal support structure.
9. The stent of claim 2 wherein said skeletal support structure has openings and said second shape is configured to extend within said openings of said skeletal support structure.
10. The stent of claim 1 wherein said shape memory material includes a shape memory polymer.
11. The stent of claim 2 wherein said shape memory material is a fabricated open-cell material.
12. An implant body for treating vasculature including a shape memory polymer capable of a first temporary compacted shape for endovascular introduction and a second memory expanded shape for altering blood flow parameters in a targeted region of the vasculature.
13. An implant body as in claim 12 wherein the shape memory polymer is coupled to struts of an expandable stent.
14. An implant body as in claim 12 wherein the shape memory polymer has an elongated configuration for occluding a blood vessel.
15. An implant body as in claim 12 wherein the shape memory polymer comprises a constraint for constraining an interior portion of the implant body.
16. An implant body as in claim 12 wherein the shape memory polymer is at least one of bioerodible and bioabsorbable.
17. A method of treating an arteriovascular malformation (AVM) comprising introducing a stent in a collapsed shape into a blood vessel, expanding the stent in or proximate to an AVM, and altering the shape of a shape-transformable polymer structure coupled to surface portions of the stent to alter blood flow parameters in or proximate to the AVM.
18. A method of treating an aneurysm comprising introducing a stent in a collapsed shape into a blood vessel, expanding the stent in or proximate to an aneurysm, and altering the shape of a shape-transformable polymer structure coupled to surface portions of the stent to alter blood flow parameters in or proximate to the aneurysm.

* * * * *