



US 20070055342A1

(19) **United States**

(12) **Patent Application Publication**

**Wu et al.**

(10) **Pub. No.: US 2007/0055342 A1**

(43) **Pub. Date: Mar. 8, 2007**

(54) **DELIVERY SYSTEM FOR MEDICAL DEVICES**

(76) Inventors: **Patrick P. Wu**, Mountain View, CA (US); **Keif Fitzgerald**, San Jose, CA (US); **Stephanie Klocke**, Chandler, AZ (US)

Correspondence Address:  
**FULWIDER PATTON**  
**6060 CENTER DRIVE**  
**10TH FLOOR**  
**LOS ANGELES, CA 90045 (US)**

(21) Appl. No.: **11/580,431**

(22) Filed: **Oct. 13, 2006**

**Related U.S. Application Data**

(60) Division of application No. 10/946,944, filed on Sep. 22, 2004, which is a continuation-in-part of application No. 10/661,406, filed on Sep. 12, 2003.

**Publication Classification**

(51) **Int. Cl.**  
**A61F 2/06** (2006.01)

(52) **U.S. Cl.** ..... **623/1.11**

(57) **ABSTRACT**

The invention is directed to a delivery system for implantation a self-expanding medical device in a body which includes a control handle and a catheter portion. The catheter portion includes an outer restraining member which covers the collapsed, medical device, an inner catheter member having a distal end including a region upon which the medical device is mounted, and an outer sheath which is removably attached to the control handle. The outer sheath creates a conduit for the catheter portion to prevent the inner catheter member from moving axially when the outer restraining member is retracted. The control handle has a rotatable thumbwheel to actuate a retraction mechanism attached to the proximal end of the outer restraining member which moves the restraining member in a proximal direction to deploy the medical device.

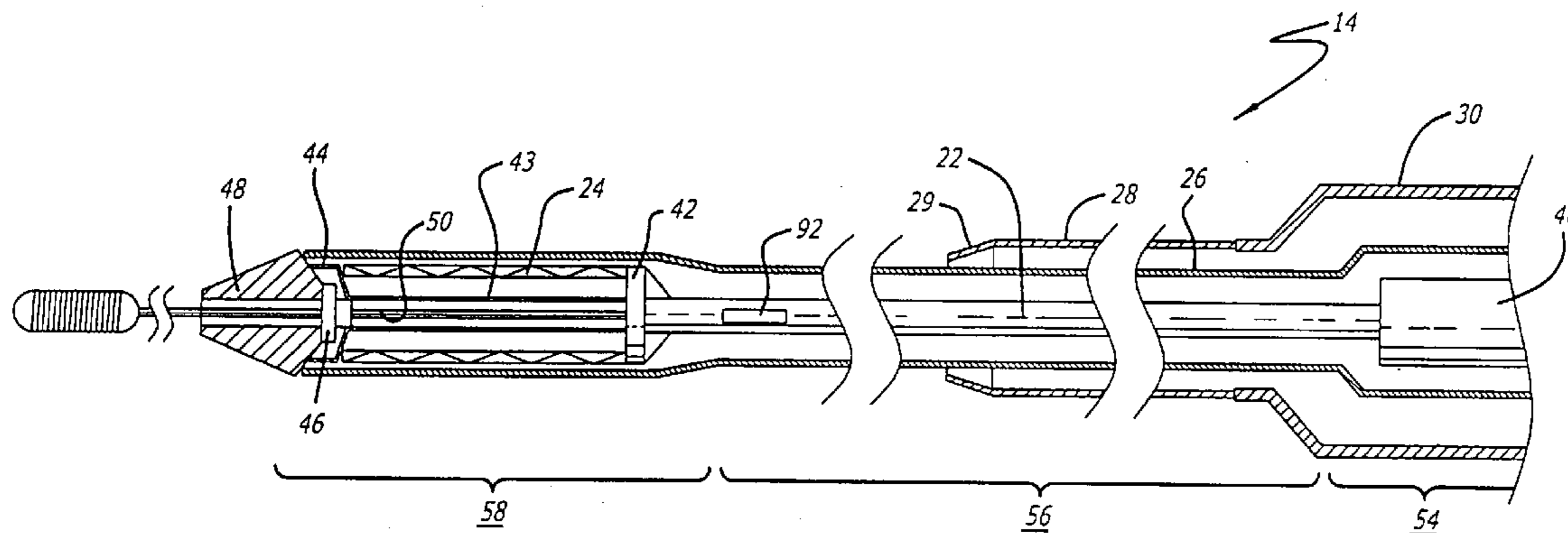

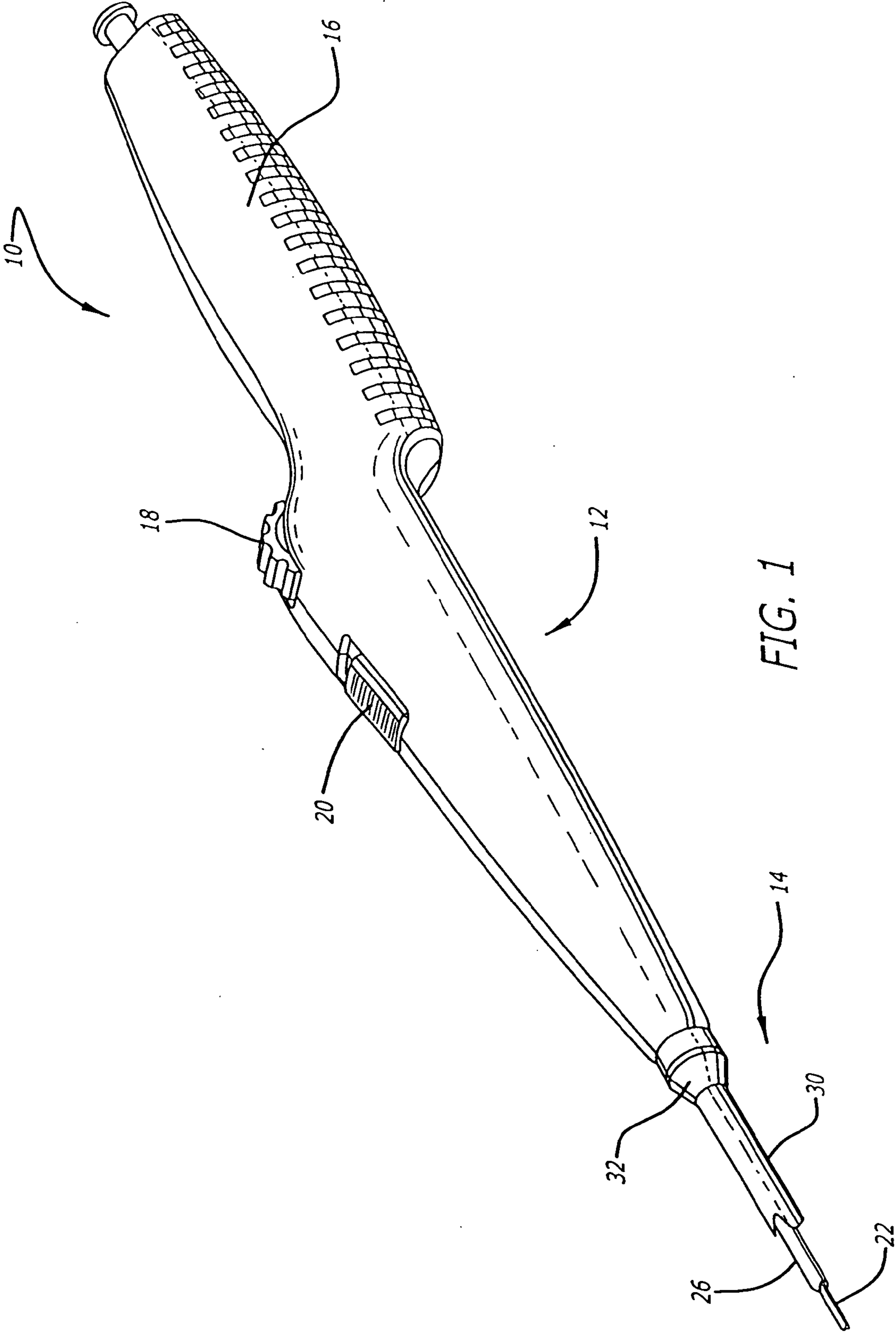

FIG. 1

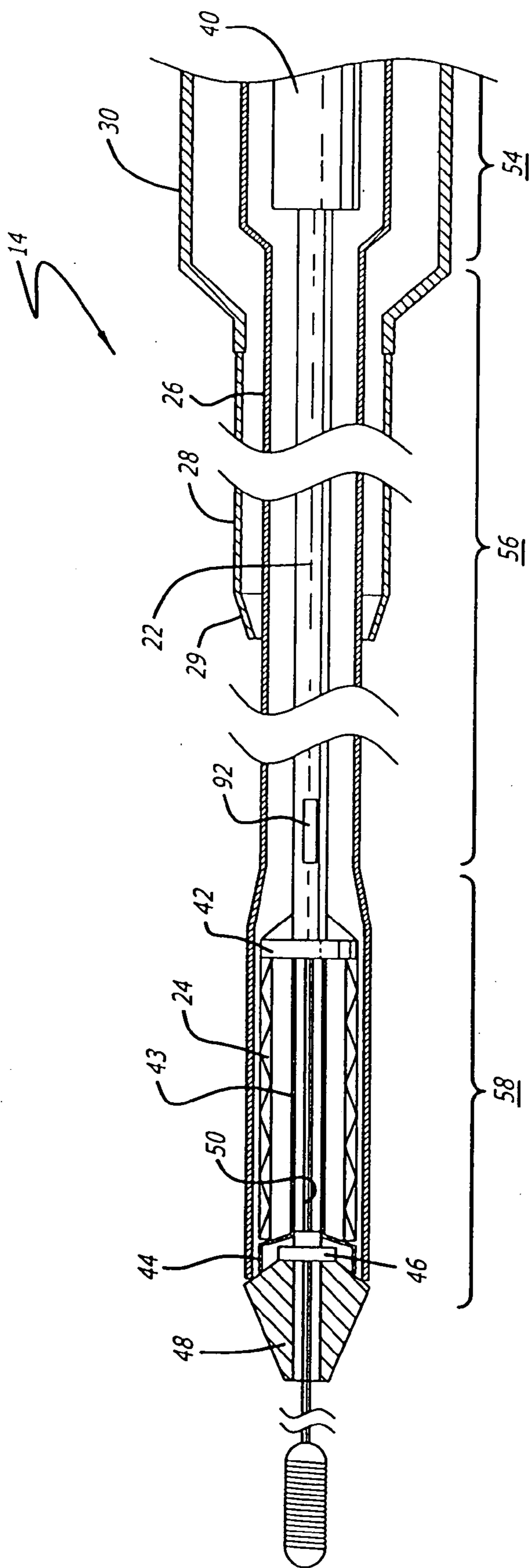

FIG. 2

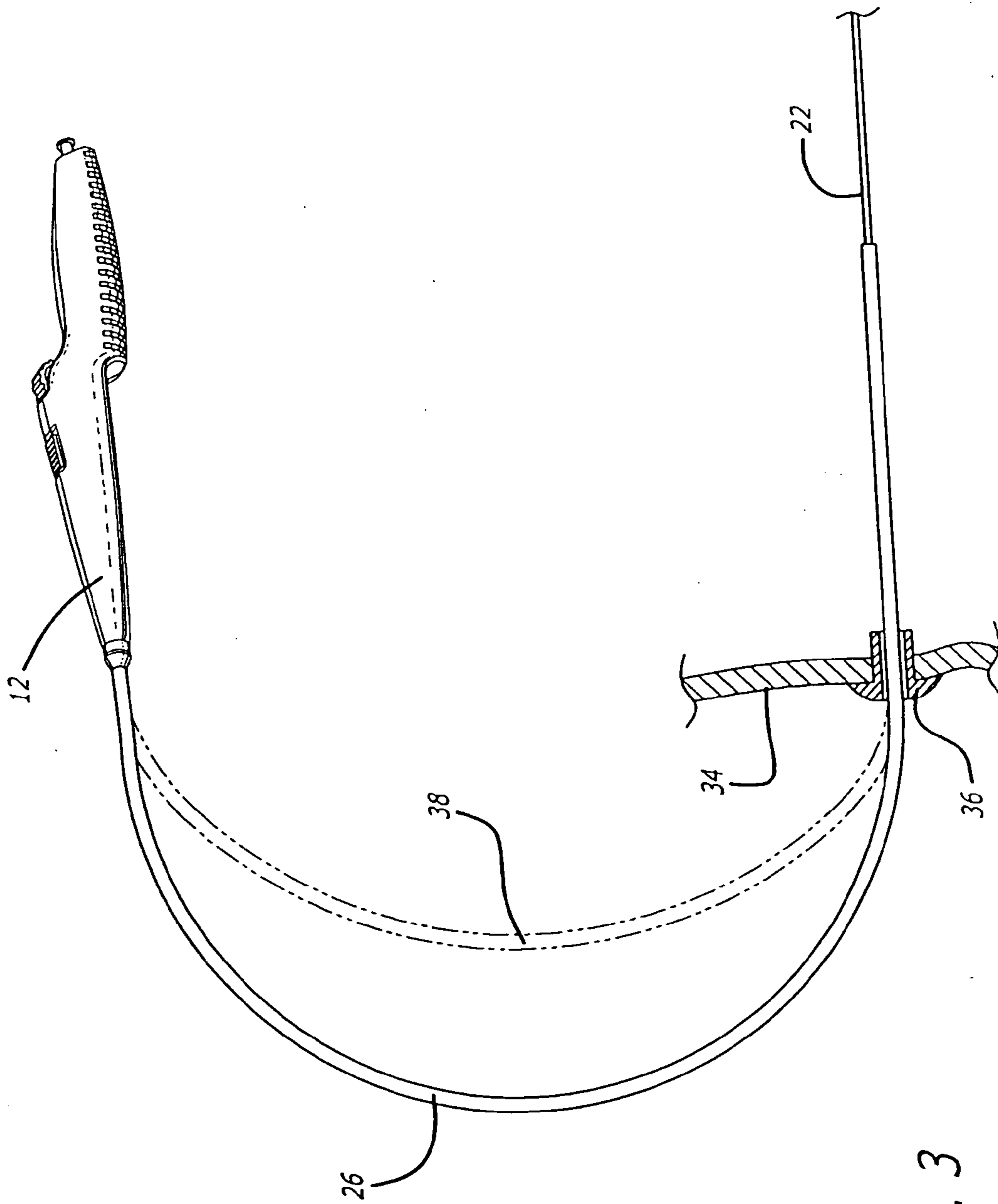
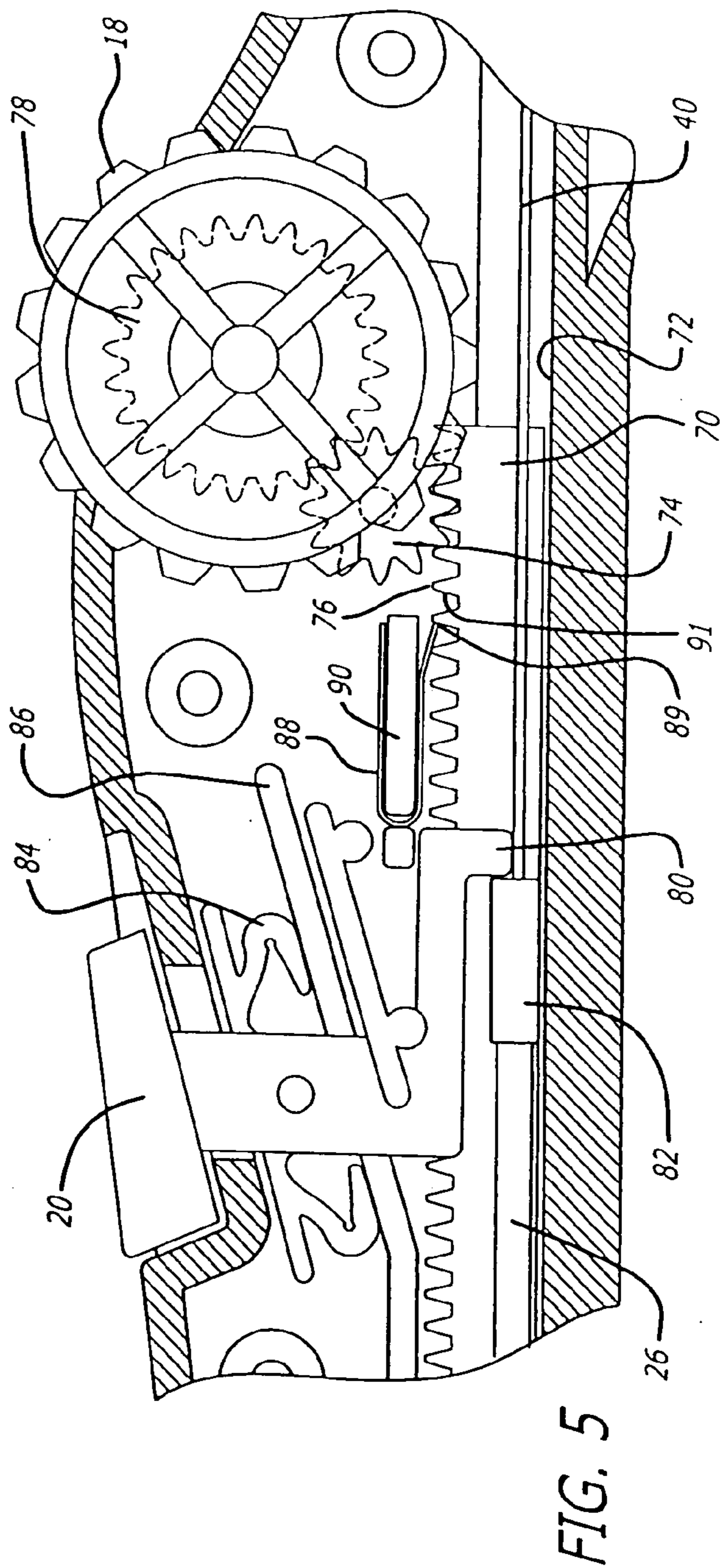
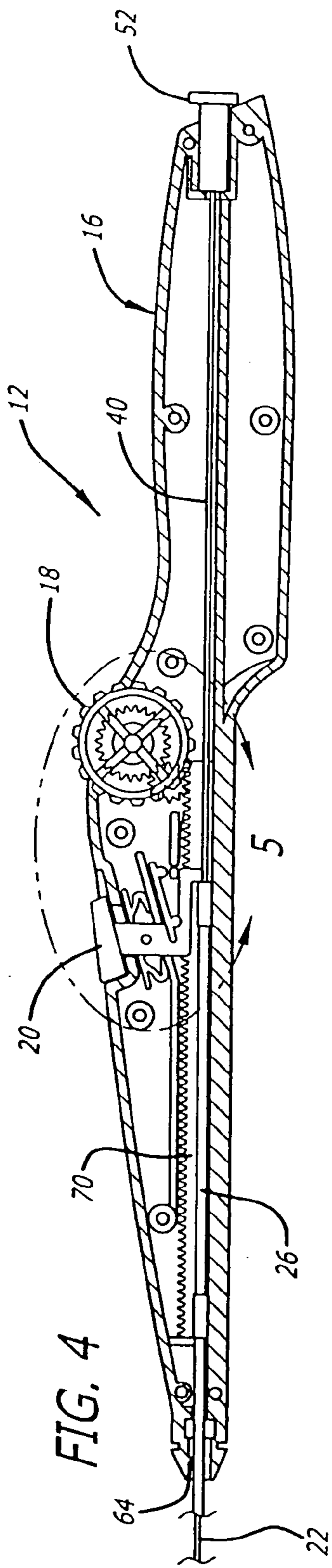

FIG. 3





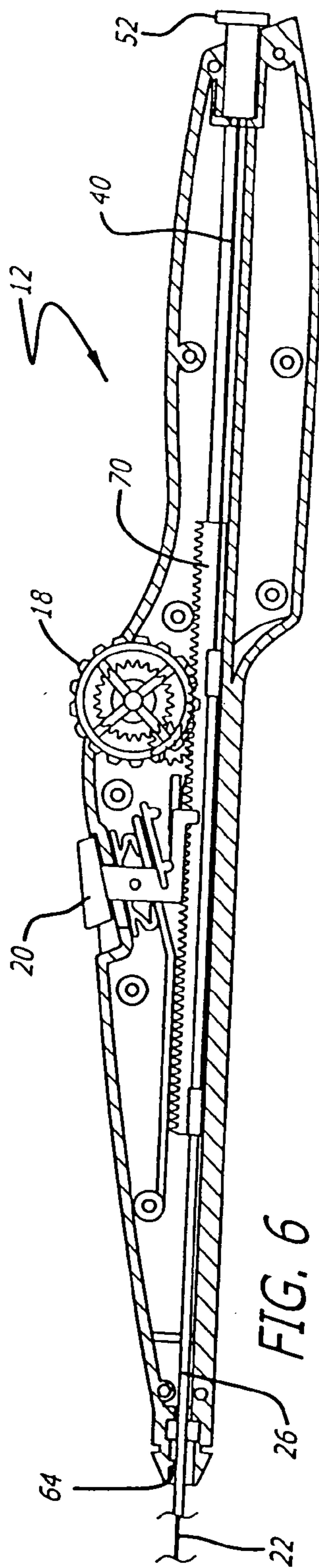

FIG. 6

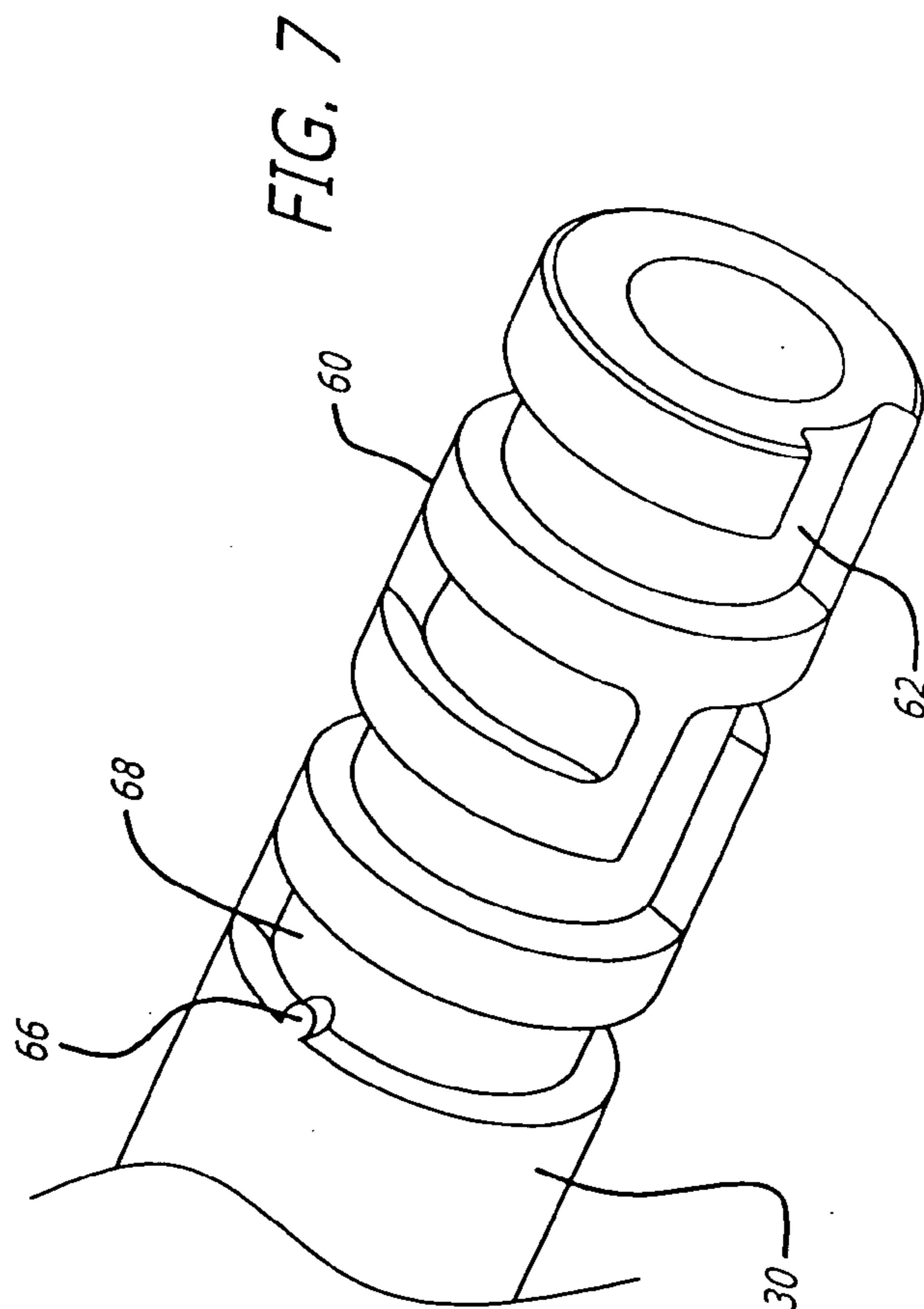

FIG. 7

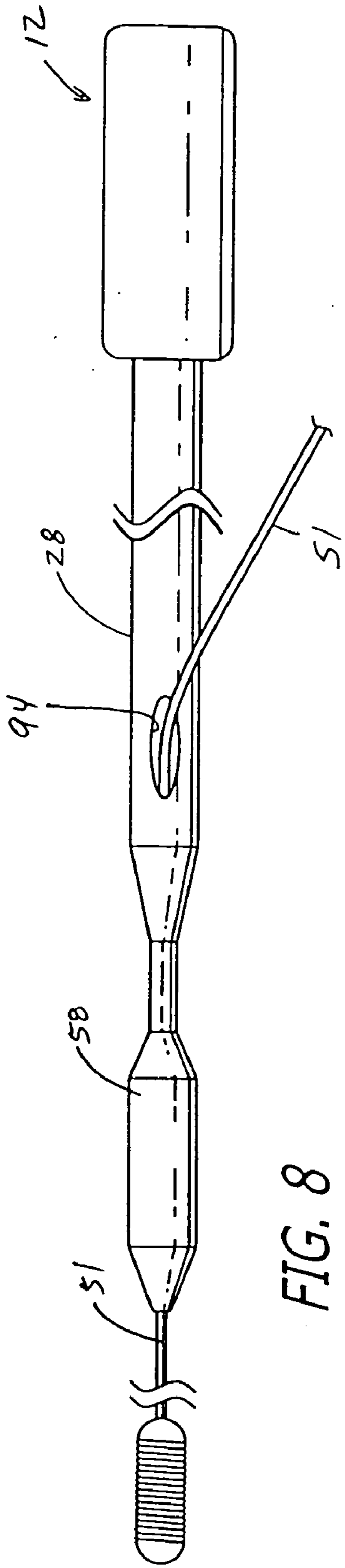

FIG. 8

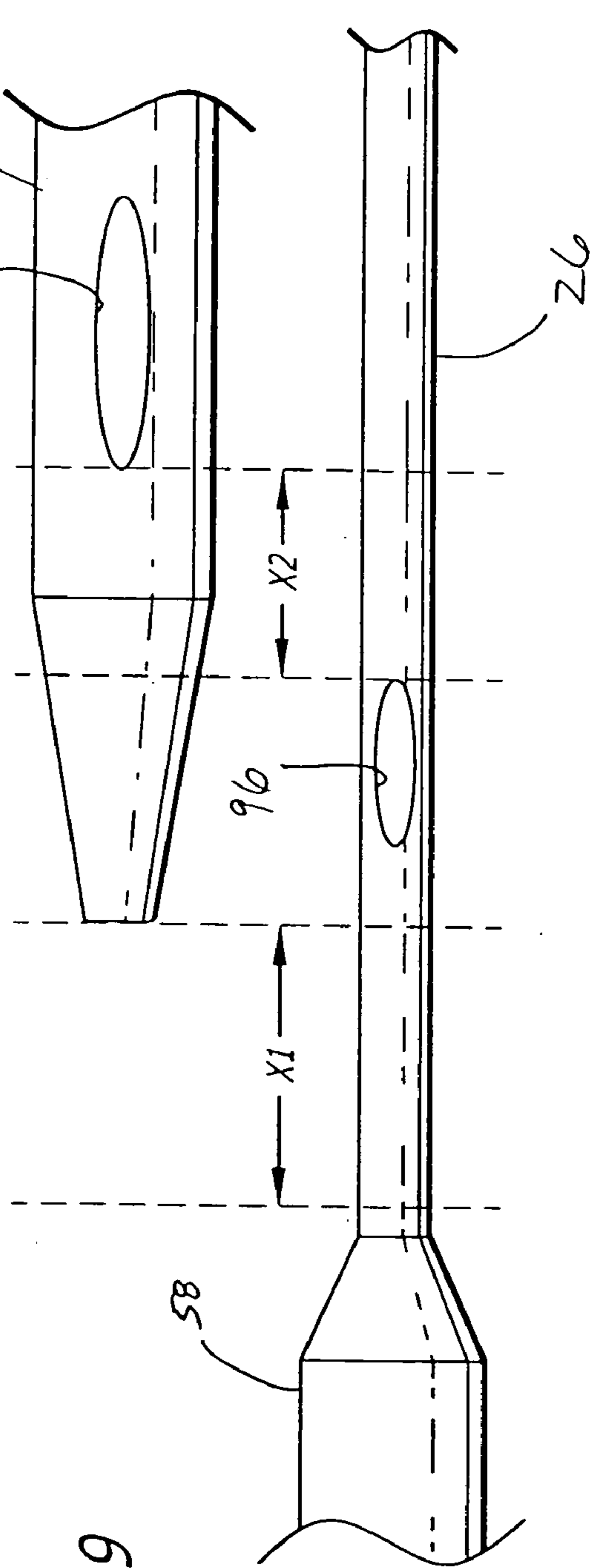

FIG. 9

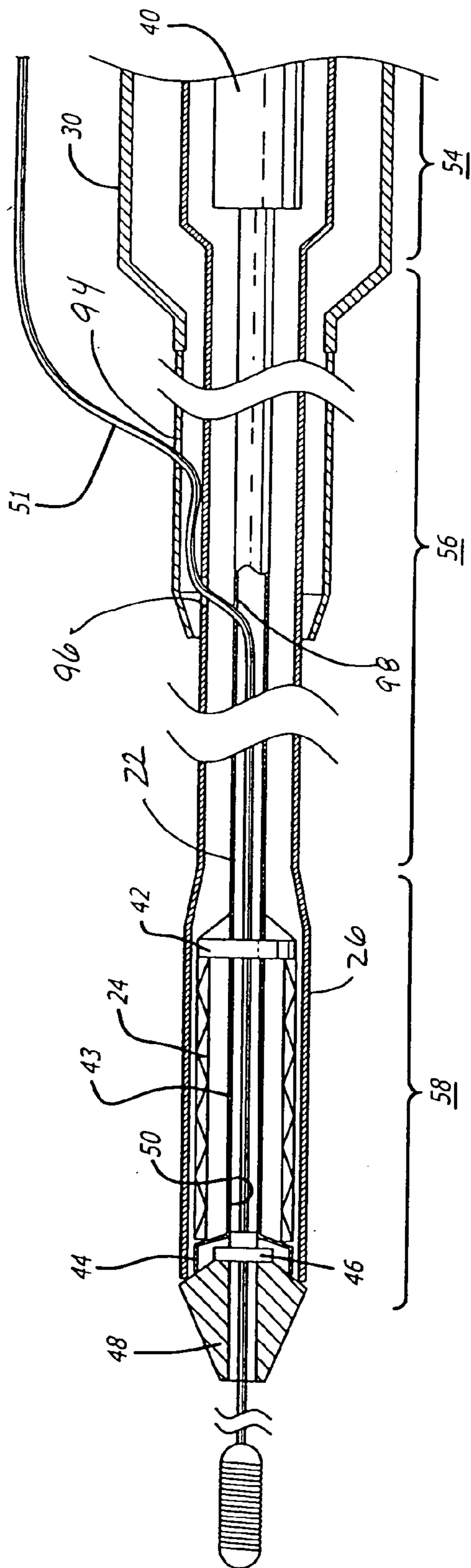

FIG. 10



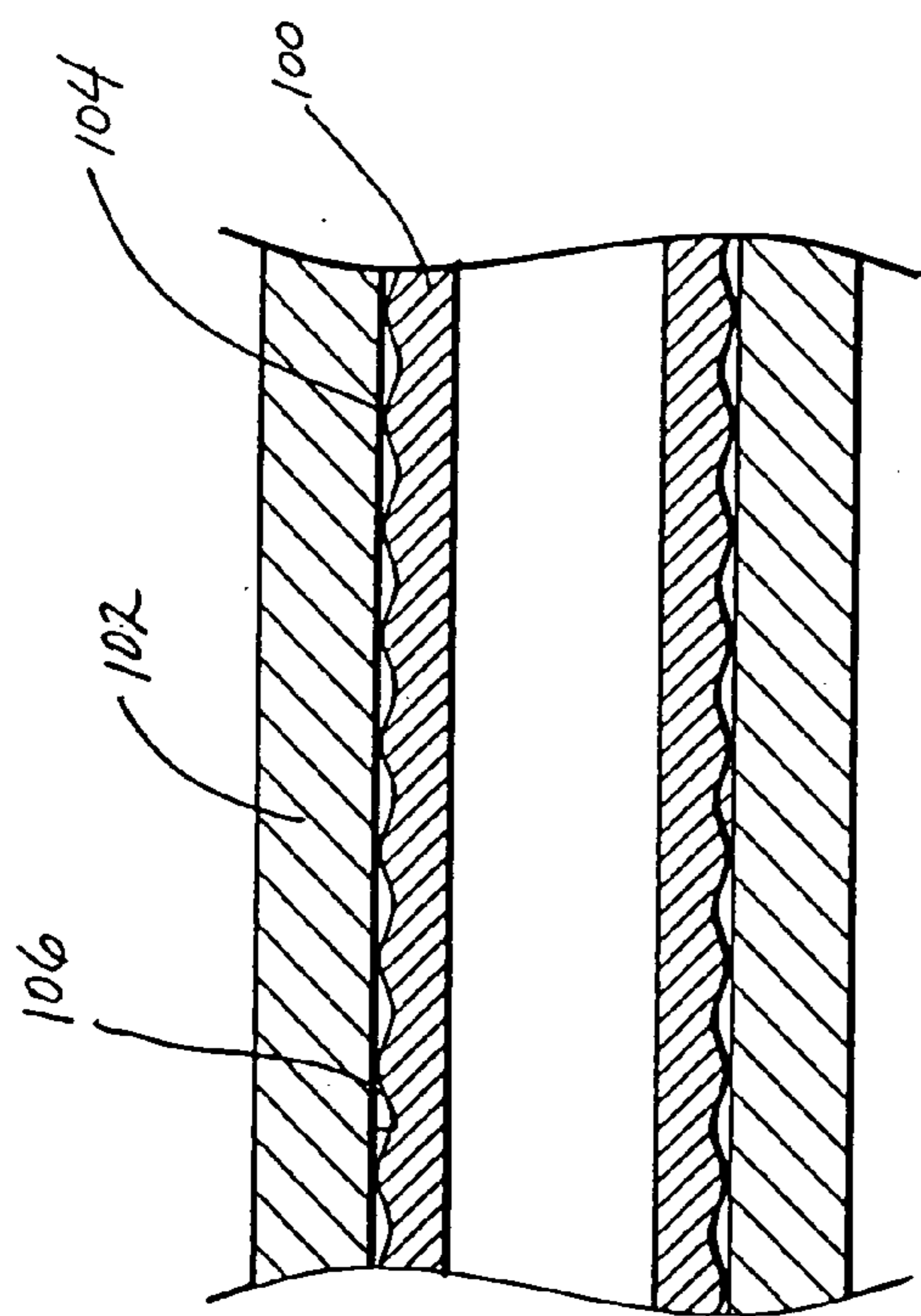

FIG. 11

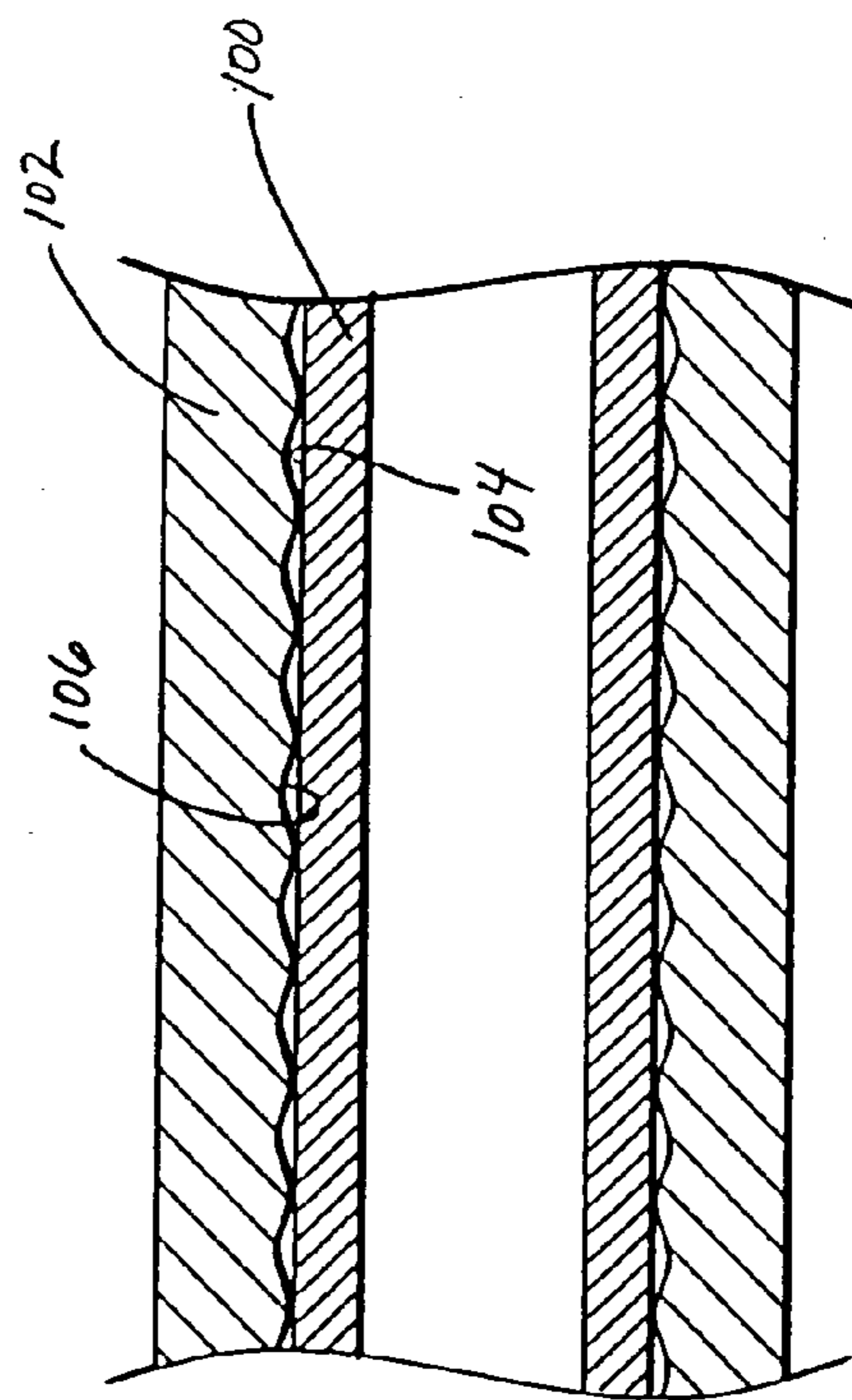

FIG. 13

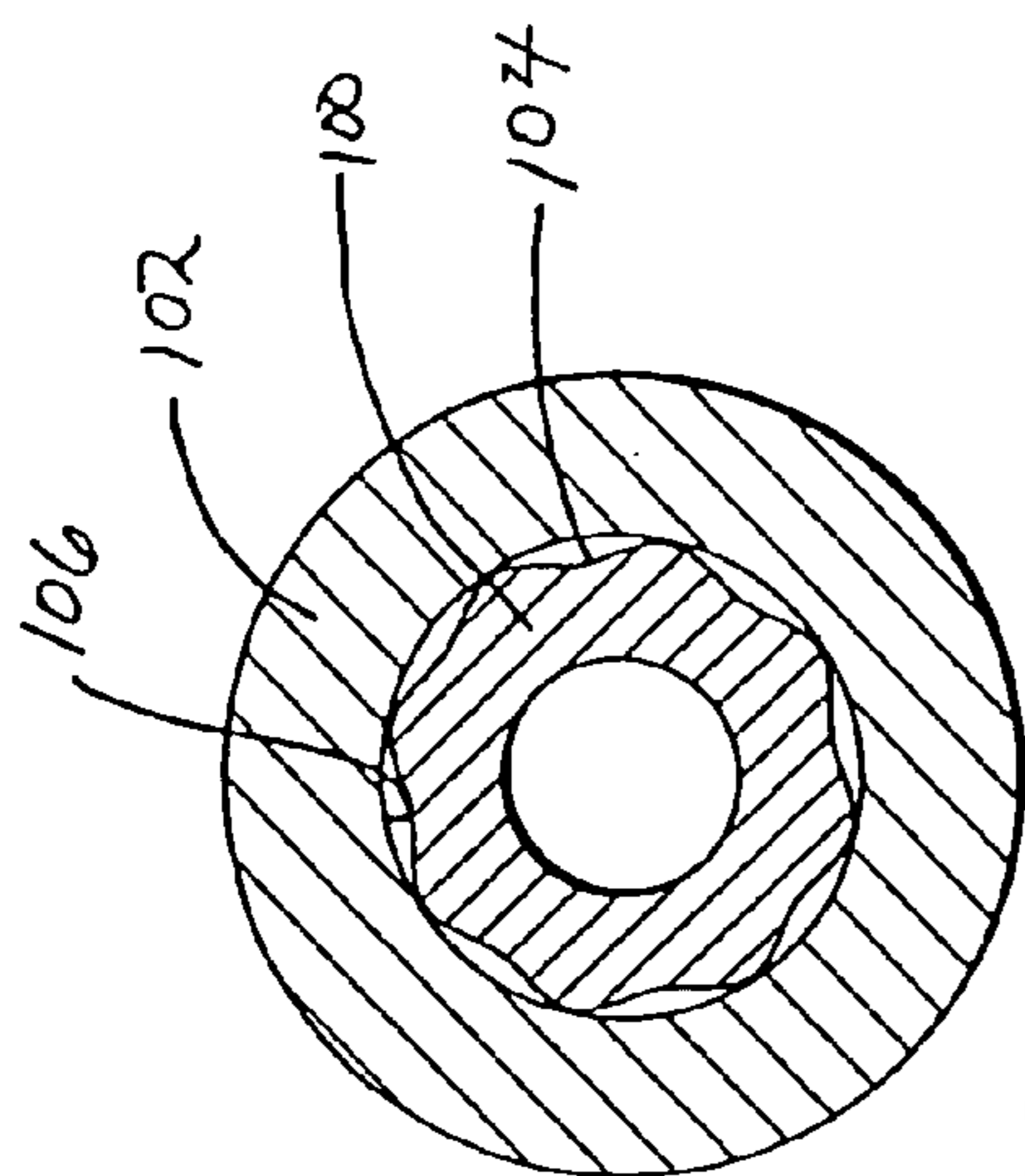

FIG. 12

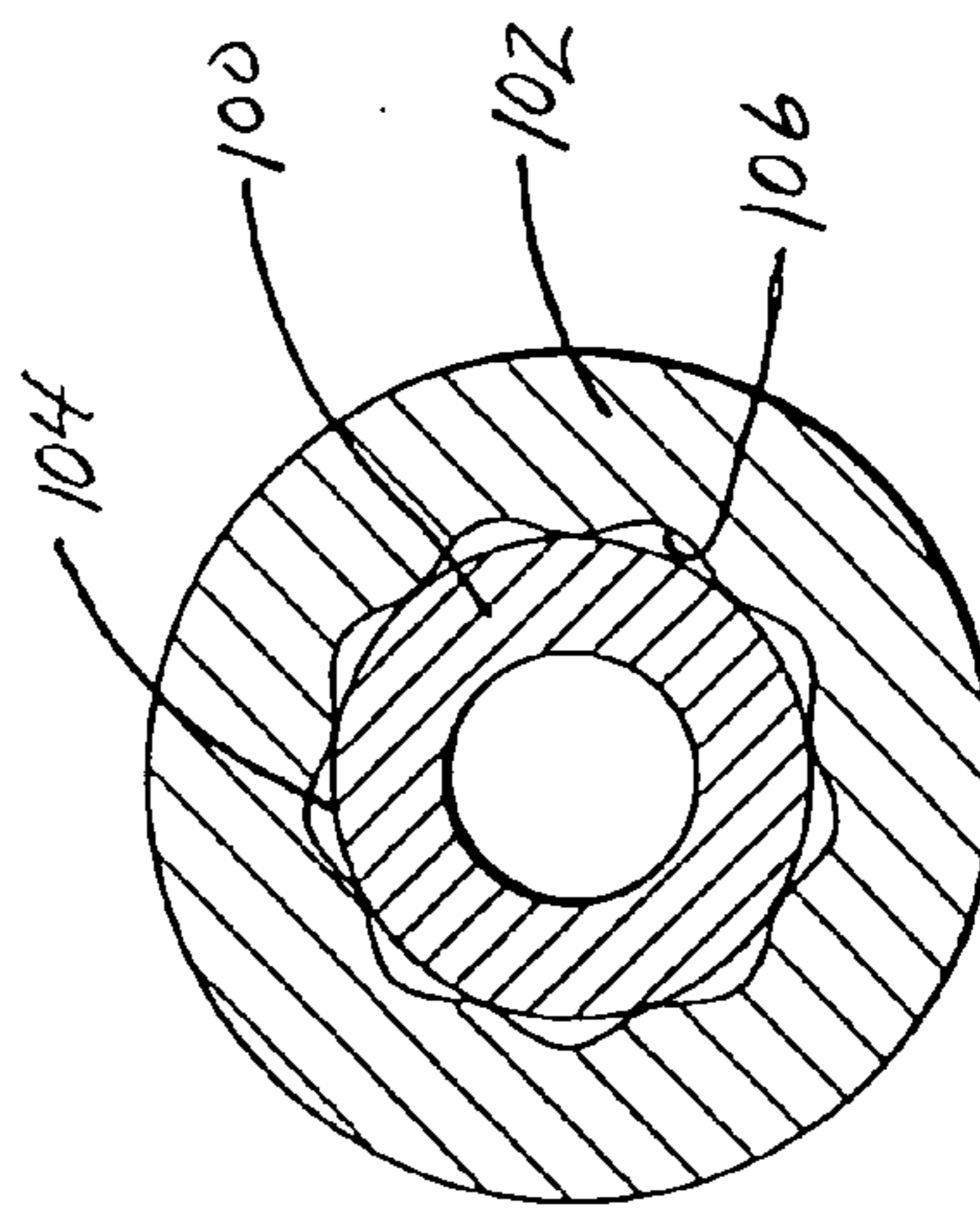

FIG. 14

FIG. 15

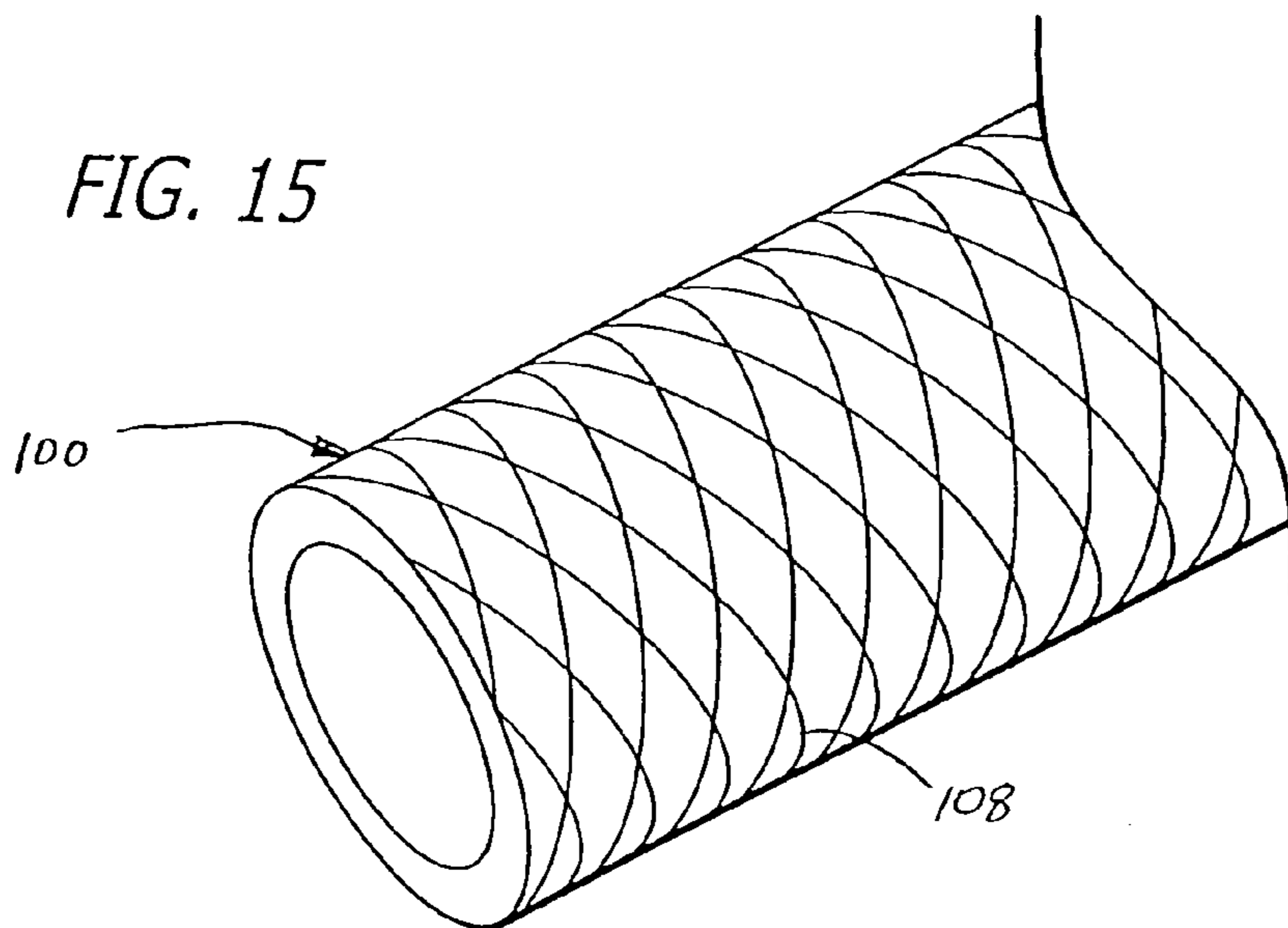

FIG. 16

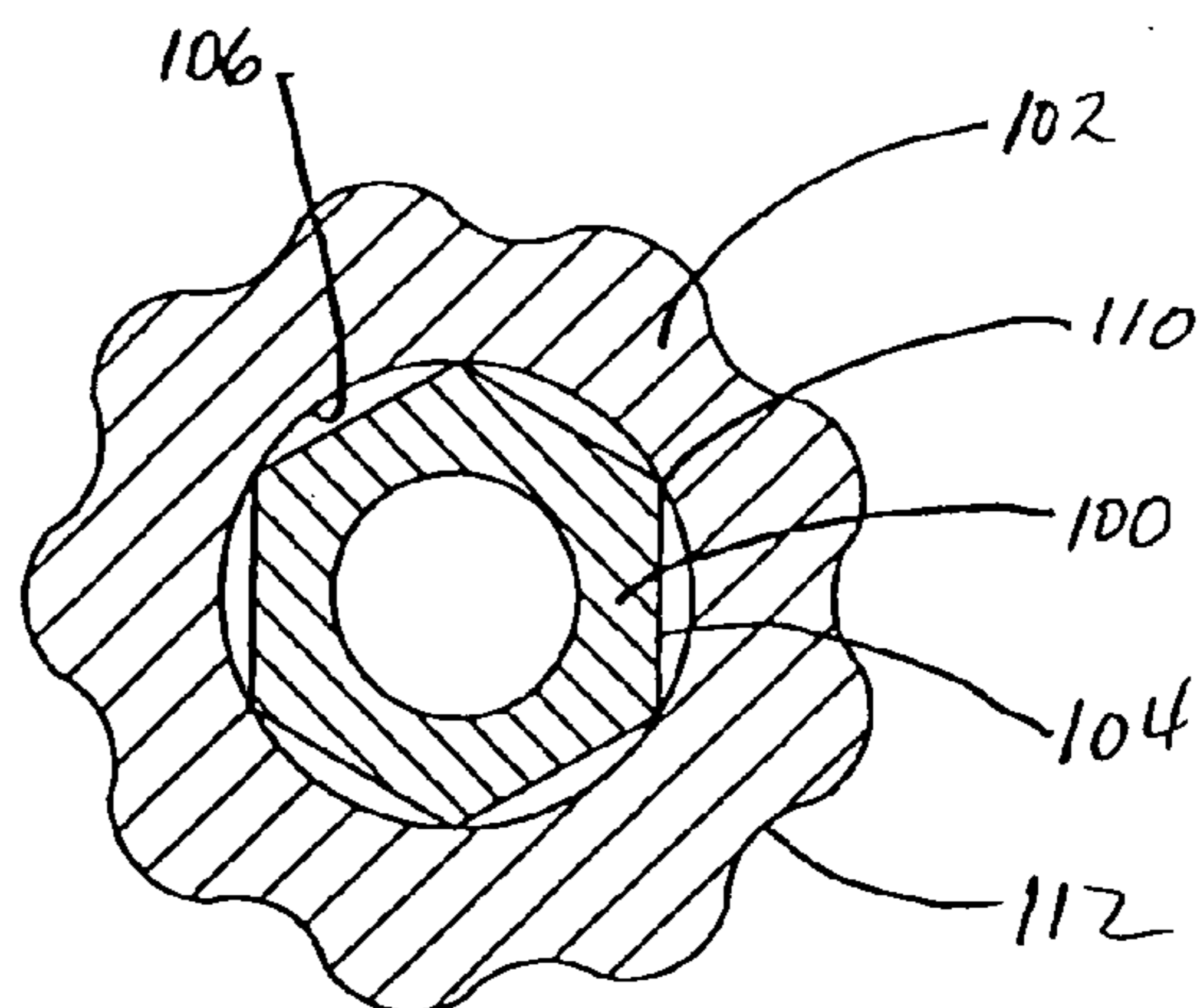
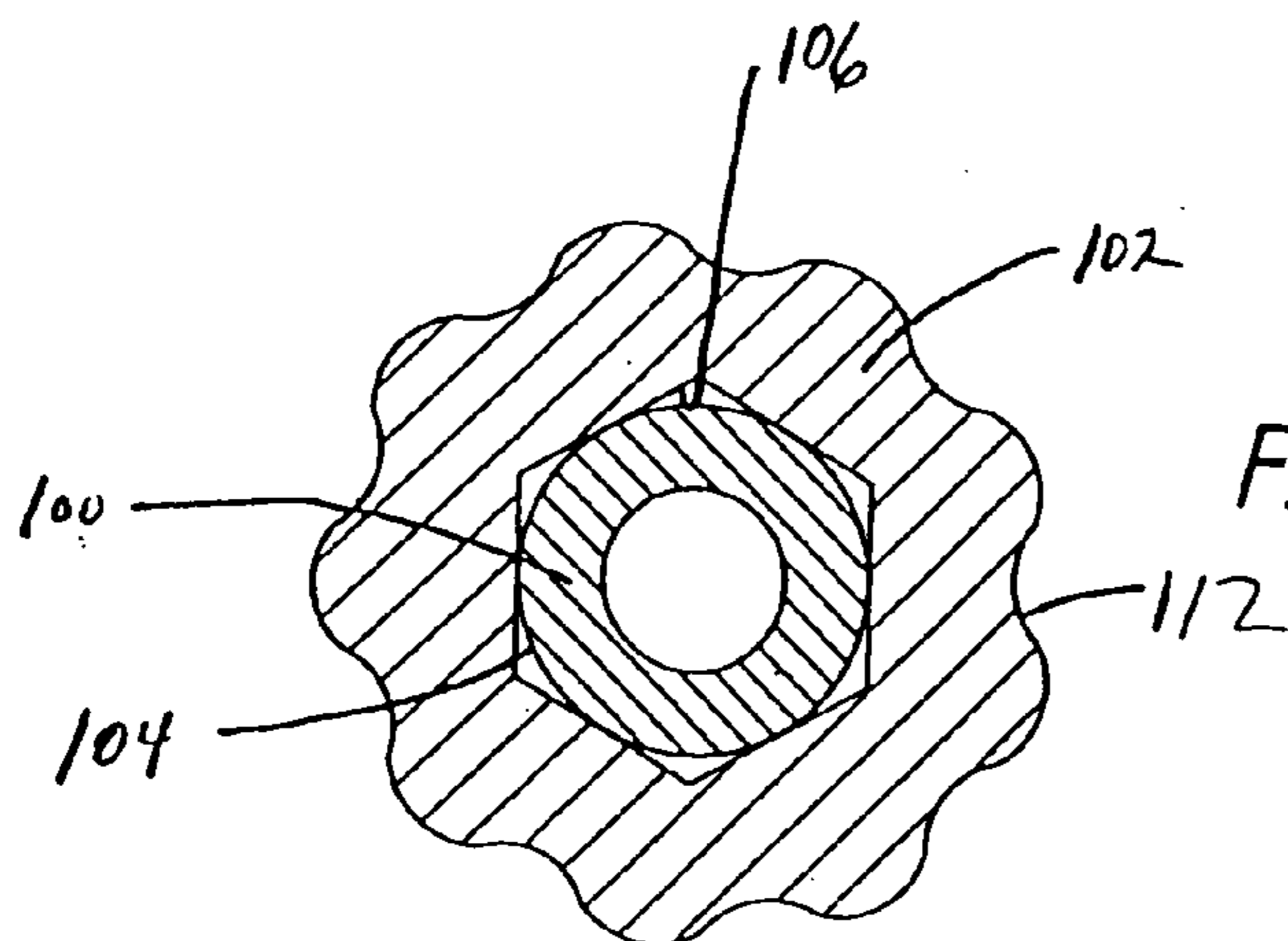

FIG. 17





## DELIVERY SYSTEM FOR MEDICAL DEVICES

### CROSS-REFERENCE TO RELATED APPLICATION

[0001] This application is a continuation-in-part of Ser. No. 10/661,406 filed Sep. 12, 2003, which is assigned to the same Assignee as the present application, the contents of which are hereby incorporated by reference.

### BACKGROUND OF THE INVENTION

[0002] The present invention relates generally to delivery systems for delivering and deploying medical devices, such as stents, which are adapted to be implanted into a patient's body, such as a blood vessel and, more particularly, to a delivery system for more accurately deploying a self-expanding medical device into an area of treatment.

[0003] Stents are generally cylindrically shaped devices which function to hold open and sometimes expand a segment of a blood vessel or other arterial lumen, such as coronary artery. Stents are usually delivered in a compressed condition to the target site and then deployed at that location into an expanded condition to support the vessel and help maintain it in an open position. They are particularly suitable for use to support and hold back a dissected arterial lining which can occlude the fluid passageway there through. Stents are particularly useful in the treatment and repair of blood vessels after a stenosis has been compressed by percutaneous transluminal coronary angioplasty (PTCA), percutaneous transluminal angioplasty (PTA), or removed by atherectomy or other means, to help improve the results of the procedure and reduce the possibility of restenosis. Stents, or stent-like devices, are often used as the support and mounting structure for implantable vascular grafts which can be used to create an artificial conduit to bypass the diseased portion of the vasculature, such as an abdominal aortic aneurism.

[0004] A variety of devices are known in the art for use as stents and have included coiled wires in a variety of patterns that are expanded after being placed intraluminally on a balloon catheter; helically wound coiled springs manufactured from an expandable heat sensitive metal; and self-expanding stents inserted into a compressed state for deployment into a body lumen. One of the difficulties encountered in using prior art stents involve maintaining the radial rigidity needed to hold open a body lumen while at the same time maintaining the longitudinal flexibility of the stent to facilitate its delivery and accommodate the often tortuous path of the body lumen.

[0005] Prior art stents typically fall into two general categories of construction. The first type of stent is expandable upon application of a controlled force, often through the inflation of the balloon portion of a dilatation catheter which, upon inflation of the balloon or other expansion means, expands the compressed stent to a larger diameter to be left in place within the artery at the target site. The second type of stent is a self-expanding stent formed from shape memory metals or superelastic nickel-titanium (NiTi) alloys, which will automatically expand from a compressed state when the stent is advanced out of the distal end of the delivery, or when a restraining sheath which holds the compressed stent in its delivery position is retracted to expose the stent.

[0006] Some prior art stent delivery systems for delivery and implanting self-expanding stents include an member lumen upon which the compressed or collapsed stent is mounted and an outer restraining sheath which is initially placed over the compressed stent prior to deployment. When the stent is to be deployed in the body vessel, the outer sheath is moved in relation to the inner member to "uncover" the compressed stent, allowing the stent to move to its expanded condition. Some delivery systems utilize a "push-pull" type technique in which the outer sheath is retracted while the inner member is pushed forward. Another common delivery system utilizes a simple pull-back delivery system in which the self-expanding stent is maintained in its compressed position by an outer sheath. Once the mounted stent has been moved at the desired treatment location, the outer sheath is pulled back via a deployment handle located at a remote position outside of the patient, which uncovers the stent to allow it to self-expand within the patient. Still other delivery systems use an actuating wire attached to the outer sheath. When the actuating wire is pulled to retract the outer sheath and deploy the stent, the inner member must remain stationary, preventing the stent from moving axially within the body vessel.

[0007] However, problems have been associated with such prior art delivery systems. For example, systems which rely on a "push-pull design" or "pull-back design" can experience unwanted movement of the collapsed stent within the body vessel when the inner member is pushed forward which can lead to inaccurate stent positioning. Systems which utilize a "pull back" system or an actuating wire design will tend to move to follow the radius of curvature when placed in curved anatomy of the patient. As the outer sheath member is actuated, tension in the delivery system can cause the system to straighten. As the system straightens, the position of the stent changes because the length of the catheter no longer conforms to the curvature of the anatomy. This change of the geometry of the system within the anatomy can lead to inaccurate stent positioning.

[0008] Delivery systems which utilize the "pull-back" type technique usually require removal of "slack" developed between the outer sheath and the inner catheter member upon which the stent is mounted. Generally, the exposed catheter, i.e. the portion of the outer member which remains outside of the patient, must usually be kept straight or relatively straight during deployment. Failure to do so may result in deploying the stent beyond the target area and can cause the stent to bunch up. This phenomenon occurs because the inner catheter member tends to move forward when the outer sheath is retracted. The reason why this happens is because the inner catheter member and outer catheter member are typically the same length prior to stent deployment. The length of the exposed catheter, again, the portion of the outer catheter which extends between the deployment handle and the insertion point in the patient, however, is usually fixed. When the outer sheath is retracted proximally into the deployment handle during deployment, the length of the exposed outer sheath tends to shorten. The inner catheter member, however, remains the same length as it is held fixed in the deployment handle. However, the outer sheath tends to shorten during deployment, thus changing the shape of the exposed portion of the catheter. This shape change occurs because the outer sheath wants to straighten out once it's being retracted. Since the inner catheter member is fixed proximally within the deployment handle, it will



move distally as the outer sheath is retracted. As a result, the movement of the inner catheter member caused by the retraction of the outer sheath can cause the stent to deploy prematurely and at a location beyond the targeted site. As a result, less than accurate deployment of the stent can occur.

[0009] This problem usually does not exist when the delivery system is kept straight during deployment as the outer sheath is allowed to slide proximally relative to the inner catheter member. However, if the delivery system is not kept straight during deployment, then the inner catheter member has this tendency to move distally during deployment. This change in the shape of the exposed catheter forces the inner catheter member to change shape as well in order for the inner catheter member to maintain the same length as the outer sheath. Since the inner catheter member is fixed within the deployment handle, it can only move distally. Consequently, the inner catheter member moves distally along with the mounted stent, causing the stent to be deployed beyond the targeted site in the patient's anatomy.

[0010] The above-described stent delivery systems also can be somewhat difficult to operate with just one hand, unless a mechanical advantage system (such as a gear mechanism) is utilized. Often, deployment with one hand is desirable since it allows the physician to use his/her other hand to support a guiding catheter which may be utilized during the procedure. The above-described stent delivery systems should not be susceptible to any axial movement of the catheters during stent deployment. Even a slight axial movement of the catheter assembly during deployment can cause some inaccurate placement of the stent in the body lumen. Some stent delivery systems employ a control handle which utilizes a pistol grip actuator that requires the physician to repeatedly pull back a trigger mechanism to cause the outer sheath to retract. In doing so, the physician usually creates a backwards force on the delivery system which also can cause the catheter portion of the delivery system to move within the patient's vasculature, resulting in less than accurate placement of the stent within the patient. Also, some of these stent delivery systems have a limited range of retraction of the outer sheath which can limit the use of the delivery system to smaller medical devices which require only a small amount of retraction in order to expand the device. Larger medical devices, such as vasculature grafts, may not be deployed because the control handle of the system may not retract the outer sheath a sufficient length in order to expose the entire graft.

[0011] Other problems associated with stent delivery systems include the buildup of frictional forces between the contacting surfaces of the tubing utilized to form the catheter portion of the delivery system. In some stent delivery system designs, there is often a sizable length of tubing which extends co-axially within another tubing, for example, an inner tubular member utilized to mount the collapsed stent and an outer retractable sheath utilized to cover the collapsed stent until the stent is ready to be deployed. Due to the surface contact between the particular surfaces of the tubular members, both static friction and dynamic friction can develop and effect the amount of force which must be developed by the control handle of the delivery system in order to retract the outer sheath. Certainly, a physician/surgeon does not wish to utilize a control handle which requires an appreciable amount of force to be exerted in order to retract the outer sheath. The physician also desires

a control handle which will provide a smooth and steady retraction motion. Unfortunately, frictional buildup can possibly effect the performance of the control handle. For these reasons, it is beneficial if the amount of friction between sliding surfaces be reduced as much as possible in order to increase performance of the delivery system.

[0012] A stent delivery system which uses rapid exchange (Rx) technology can allow for quicker handling and delivery of the delivery system over the guide wire. A Rx platform enables the physician to load the distal end of the catheter portion onto the proximal end of the guide wire using a small guide wire lumen formed at the distal end of the catheter portion. The Rx design eliminates the need for a long guide wire lumen which extends from the proximal end of the system to the distal end. Additionally, a Rx design eliminates the need to have a large length of guide wire extending outside of the patient since the guide wire lumen is relatively short in length. The Rx design also tends to allow the distal end of the catheter to be more quickly delivered over the guide wire into the area of treatment.

[0013] Thus, there is a need for a delivery system for delivering and deploying a self-expanding medical device, such as a stent, which prevents the axial movement of the inner catheter member relative to the outer sheath to prevent the inner catheter member from moving forward during deployment. Such a delivery system also should compensate for any slack that may be present in the delivery system and should prevent the inner catheter member from moving forward within the patient's vasculature as the outer restraining sheath is being retracted from the self-expanding medical device. A delivery system having these features would be beneficial if it allowed the physician to actuate the system with only one hand, thus allowing the physician to use his/her other hand during the procedure. Additionally, a stent delivery system including these features in a Rx design would be highly beneficial. Also, a delivery system which reduces the amount of frictional forces generated between moving components of the catheter portion of the system should improve deployment performance. The present invention disclosed herein satisfies these and other needs.

#### SUMMARY OF THE INVENTION

[0014] The present invention is directed to a delivery system for delivering and more accurately deploying a medical device, such as a stent, to the target site in a body lumen. The delivery system in accordance with the present invention incorporates unique features which facilitates minimal movement during device deployment, accurate placement, and single-handed system operation. The delivery system of the present invention can be manufactured in an Rx design or platform to improve the speed in delivering the catheter portion of the delivery system into the target area. Additionally, the present invention includes a feature which helps to reduce the buildup of frictional forces between moving components of the catheter portion of the system, thus reducing the amount of force necessary to be delivered to deploy the stent. While the delivery system can be used to deploy any self-expanding stent, it also can be used to deploy other self-expanding medical devices, including medical devices which are not self-expanding as well.

[0015] In one aspect of the present invention, the delivery system include a control handle and a catheter portion which



is designed for advancement to a target area in a patient's body lumen over a deployed guide wire using "over the wire" techniques known in the art. The catheter portion includes an inner catheter member having a proximal portion attached within the control handle and a distal portion upon which the medical device is mounted in a collapsed position. An outer restraining member extends over the inner catheter member in a coaxial arrangement. The outer restraining member holds the medical device in the collapsed position until the device is to be deployed. If the medical device is not self-expanding, the outer restraining member does not necessarily restrain the device, but provides a protective cover for the device. The outer restraining member is retractable to release the medical device by a retraction mechanism housed in the control handle. The control handle includes a rotatable thumbwheel which is easily moveable to provide a manual mechanism for retracting the restraining sheath. The control handle immobilizes the inner catheter member, preventing it from moving relative to the outer restraining member during deployment. The control handle allows the delivery system to be operated by just one hand, freeing the physician's other hand for other purposes, such as stabilizing the guiding catheter during deployment of the medical device.

[0016] In one aspect of the present invention, the catheter portion includes an outer sheath which is utilized to stiffen the catheter portion of the delivery system so that the inner catheter member will not change shape outside the body when the outer restraining member is retracted to deploy the medical device. The outer sheath extends at least partially over the length of the outer restraining member in a coaxial relationship in order to create a conduit between the control handle and the point of insertion into the patient. This outer sheath helps to reduce frictional forces which may be created with the medical device that is inserted into the patient to obtain entry for the catheter portion, such as a rotating hemostatic valve (RHV), or other similar device, and helps to prevent the inner catheter member from moving distally as the outer restraining sheath is being retracted via the control handle.

[0017] In another aspect of the present invention, the outer sheath is attached to a strain relief member which is threadingly engaged with the control handle. In this particular aspect of the invention, the proximal end of the strain relief has a channel formed in it which is designed to receive a tab-like projection formed in a recess of the control housing in order to allow the strain relief member to be threaded onto the control handle. Depending upon physician preference, the outer sheath can either remain or be removed from the control handle during use.

[0018] In another aspect of the present invention, the retraction mechanism of the control handle allows the outer restraining member to be retracted in a proximal direction only and includes a stop mechanism which prevents the retraction mechanism from prematurely deploying. The control handle allows the physician to actuate the retraction mechanism using a simple thumb motion on the thumbwheel which helps to prevent unwanted forces from acting on the control handle which can typically be developed when a pistol-like actuated control handle is utilized. As a result, a more accurate placement of the medical device may be achieved.

[0019] The inner catheter member has a guide wire lumen which extends from the distal end of the inner catheter member to the proximal end to allow a guide wire to be used to advance the catheter portion to the target area in the body lumen in an "over the wire" technique. In this regard, the catheter/medical device can be introduced within the patient's vasculature in a conventional Seldinger technique through a guiding catheter. The distal end of the inner catheter member includes a soft, low profile tip assembly with a radiopaque marker.

[0020] The catheter portion of the present delivery system also can be manufactured in an Rx design or platform which allows the catheter medical device to be more quickly introduced into the patient's vasculature utilizing the Seldinger technique. In this aspect of the present invention, the Rx design still allows the use of the outer sheath which extends over the outer restraining member in a coaxial arrangement to reduce frictional forces and improve stent deployment.

[0021] In another aspect of the present invention, the inner and outer surfaces of the tubing utilized to create the various catheter portions can be processed to help reduce the amount of surface contact and the amount of friction created when the tubing slide relative to each other. In one aspect of the present invention, one way to minimize the surface contact is to "roughen" one or both of the outer surfaces that are in sliding contact. For example, if the tubular member is a thermoplastic material, then it can be extruded so that inner and/or outer diameters have non-circular cross-sections. If the tubular member is thermoset material, then the mandrels or the dies used to form the tubular member can be designed to create the non-circular cross-sections. Alternatively, the surface of the tubing can be "roughened" utilizing an instrument which forms multiple ridges or projections on the surface of the tubular member. In this manner, the surface of the tubular member will be plastically deformed to form the small raised ridges and projections on the surface of the tubular member. These ridges or projections minimize surface contact between the sliding members which also minimizes the buildup of frictional forces as the tubular members slide relatively to each other.

[0022] These and other advantages of the present invention become apparent from the following detailed description and the accompanying exemplary drawings.

#### BRIEF DESCRIPTION OF THE DRAWINGS

[0023] FIG. 1 is a perspective view showing a control handle which forms part of the delivery system of the present invention.

[0024] FIG. 2 is an elevational view, partially in section, showing a schematic representation of the catheter portion of the delivery system which attaches to the control handle.

[0025] FIG. 3 is a perspective view of a delivery system showing the flattening of the arc during deployment in silhouette.

[0026] FIG. 4 is a cross sectional view of the control handle of FIG. 1.

[0027] FIG. 5 is an enlarged cross-sectional view of the retraction mechanism of the control handle of FIG. 4.



[0028] FIG. 6 is a cross-sectional view of the control handle of FIG. 4 in which the rack and pinion portion of the control handle has been partially retracted.

[0029] FIG. 7 is a perspective view showing the proximal end of the strain relief portion of the catheter system which is attached to the outer sheath utilized in conjunction with the present delivery system.

[0030] FIG. 8 is a plan view showing a representative embodiment of an Rx catheter design which can be implemented with the control handle of the present invention.

[0031] FIG. 9 is a plan view showing a portion of the outer restraining member and the distal end of the outer sheath of the Rx catheter design depicted in FIG. 8.

[0032] FIG. 10 is a side elevation view, partially in section, showing the Rx catheter portion of the delivery system depicted in FIGS. 8 and 9.

[0033] FIG. 11 is a cross-sectional view of an inner tubular member having a roughened outer surface as it is coaxially disposed within a lumen of an outer tubular member.

[0034] FIG. 12 is a cross sectional view of the two tubular members depicted in FIG. 11.

[0035] FIG. 13 is a cross-sectional view of an inner tubular member co-axially disposed within a lumen of an outer tubular member which has a roughened inner surface.

[0036] FIG. 14 is a cross-sectional view of the two tubular members depicted in FIG. 13.

[0037] FIG. 15 is a perspective view showing a portion of a tubular member having a schematic representation of a roughened outer surface which creates ridges or projections that helps to reduce surface contact and frictional buildup between the tubular member and another co-axially disposed tubular member.

[0038] FIG. 16 is a cross-sectional view showing an inner tubular member having a non-circular cross-section disposed within the lumen of an outer tubular member.

[0039] FIG. 17 is a cross-sectional view showing an inner tubular member disposed in the lumen of an outer tubular member having a non-circular cross-section.

#### DETAILED DESCRIPTION OF THE PREFERRED EMBODIMENTS

[0040] The present invention relates to a delivery system for delivering and deploying a medical device into a target site in a patient's body, such as a body lumen. For sake of illustration, the following exemplary embodiments are directed to a delivery system for delivering and deploying a self-expanding stent, although it is understood that the present invention is applicable to other medical devices which are implantable in a body lumen as well as other parts of the body. Additionally, the medical device can be either a self-expanding device or a non self-expanding device.

[0041] Referring now to FIGS. 1 and 2, in one particular embodiment of the present invention, the delivery system 10 incorporating features of the present invention includes a control handle 12 and a catheter portion 14. As can best be seen in FIG. 1, the control handle includes a hand portion 16 which allows the physician to hold the control handle utilizing one hand. The control handle 12 also includes a

rotatable thumbwheel 18 which allows the physician to retract the restraining sheath utilized to maintain the self-expanding medical device in its collapsed, delivery position near the distal end of the catheter portion 14 of the system. The hand portion 16 can be easily grasped by the physician and the thumbwheel 18 can be easily rotated by the physician to actuate the mechanism which pulls back the restraining sheath to expose the self-expanding stent to achieve deployment of the device within the patient. A lock mechanism 20 is utilized to maintain the catheter portion 14 of the device in a securely locked condition until the physician is ready to manipulate the thumbwheel 18 to deploy the medical device. The design of the control handle allows the physician to hold the hand portion 16 in either his/her right or left hand and easily manipulate the thumbwheel 18. Alternatively, the physician can grasp the portion of the control handle distal to the thumbwheel 18 if desired, and still be capable of easily rotating the thumbwheel 18 in order to retract the restraining sheath. This sleek design of the control handle allows added versatility when handling and deploying the delivery system made in accordance with the present invention.

[0042] Referring now specifically to FIG. 2, the catheter portion 14 is shown schematically as including an inner catheter member 22 which is adapted to carry the medical device, such as a self-expanding stent 24, near the distal end of the inner catheter member 22. An outer restraining member extends generally coaxially over the inner catheter member 22 and is designed to maintain the stent 24 in its collapsed delivery configuration until the stent is to be deployed by the physician. This outer restraining member 26 can be retracted via the control handle 12 in accordance with the present invention. A third catheter member forms the outermost catheter portion 14 of the system and is shown as an outer sheath 28 which is removably attached to the control handle 12. In this regard, the outer sheath 28 is coaxially disposed over the outer restraining member 26 and can be removably attached to the control handle 12 or attached to a strain relief 30 which is removably attached to a nose cone 32 forming part of the control handle 12. Further details on the construction of the removable strain relief 30 and its attachment to the nose cone 32 are described in greater detail below.

[0043] The outer sheath 28 is utilized in order to stiffen the catheter portion of the delivery system so that the arc of the inner catheter member 22 will not change shape outside the body when the outer restraining member 26 is pulled back to deploy the stent. In this regard, the inner catheter member 22 can be maintained in a stationary position relative to the control handle 12 and the outer restraining member 26 so that the inner catheter member 22 will not move distally once retraction of the outer restraining member 22 commences.

[0044] Referring specifically now to FIG. 3, the problem that exists when a delivery system does not utilize an outer sheath 28, such as the one made in accordance with the present invention, is described in greater detail. FIG. 3 shows the delivery system as it extends outside of the patient 34 (schematically represented in FIG. 3). A rotating hemostatic valve 36 is shown schematically inserted within the patient 34. In FIG. 3, the delivery system is shown without the outer sheath 28 connected to the control handle 12 and merely represents an outer restraining member 26 coaxially



disposed over the inner catheter member **22**. When the delivery system is maintained at a curvature with respect to the entry point, i.e. at the rotating hemostatic valve **36**, the inner catheter member has a tendency to move distally during the retraction of the outer restraining member. FIG. **3** shows the presence of a curvature in the exposed portion of the catheter portion prior to deployment. In this state, the lengths of the inner and outer members are substantially the same. However, the outer restraining member tends to shorten during deployment, thus changing the shape of the exposed portion of the catheter. This shape change occurs because the outer restraining member wants to straighten out once it's being retracted. This change in the shape of the outer restraining member is shown in silhouette **38** in FIG. **3**. Since the inner catheter member is fixed proximally within the control handle, it will move distally as the outer restraining member is retracted. As a result, the movement of the inner catheter member caused by the retraction of the outer restraining member can cause the stent to deploy prematurely and at a location beyond the targeted site. As a result, less than accurate deployment of the stent can occur.

[0045] The outer sheath **28** is designed to attach to the point of entry in the patient, for example the rotating hemostatic valve **36** located at the insertion opening in the patient's vasculature, to avoid the premature deployment of the stent since this outer sheath **28** creates a conduit that allows the outer restraining member **26** of the catheter portion **14** to move without excessive friction. The outer diameter of the outer sheath **28** can remain compatible to a specified sheath sizing or it can include a necked-down distal region **29** in which the inner and outer diameters of the outer sheath **28** is less than the remainder of the outer sheath. This necked-down region **29** helps to reduce the possibility of blood loss through the annular space formed between outer sheath and the outer restraining member. The outer sheath **28** ensures accurate deployment without the need to remove slack from the exposed catheter portion, i.e. the portion of the catheter which extends between the rotating hemostatic valve and the control handle. As a result, a physician utilizing the delivery system of the present invention may not be required to keep the exposed catheter portion straight or substantially straight in order to achieve accurate placement of the stent.

[0046] Referring again specifically to FIG. **2**, the various components making up the catheter portion **14** of the delivery system **10** are described in greater detail herein. The inner catheter member **22** extends from the control handle **12** to a distal portion which includes a region for mounting the self-expanding stent **24**. In one particular embodiment of the present invention, the inner catheter member **22** is a composite structure formed of two different type of tubing, each tubing having a specific function. FIG. **2** shows the inner catheter member **22** including a proximal portion **40**, made from a hypotube, which extends within the control handle **12** as is shown in FIGS. **4-6**. The distal portion **41** of the inner catheter member which is attached distal to the proximal portion **40** and can be made from polyimide material which is braided with stainless steel which serves to provide a strong, but flexible, catheter portion in order to provide good trackability and pushability over a guide wire (not shown). The application of tensile force to the shaft of the outer restraining member **26** and outer sheath **28** during stent deployment can create an equal and opposite compressive force on the inner catheter member **22**. For the outer

restraining member **26** to retract (via the movement of the control handle **12**) without causing the rest of the catheter portion **14** to buckle, the inner catheter member **22** must possess sufficient column strength to prevent buckling or deformation. Otherwise, buckling or deformation to the inner catheter member **22** can cause the distal end of the catheter portion **14** to move within the artery, causing inaccurate deployment of the stent. Therefore, the tubing used to form the distal portion **41** of the inner catheter member **22** should be fabricated from a tubular element which possesses sufficient rigidity to prevent unwanted buckling or deformation, yet is flexible enough to track along the torturous anatomy to the target site.

[0047] Alternative tubing includes a more flexible material such as polyetherketone (PEEK) or similar material which possess excellent compressive strength, yet is reasonably flexible. The proximal portion **40** can be made from hypotube which provides maximum strength, but is fairly rigid. However, this is not a concern since this proximal portion **40** of the inner catheter member **22** remains relatively straight within the control handle **12**. The distal portion of the inner catheter member **22** must exit the guiding catheter and track through the torturous anatomy to reach the target site. Therefore, this portion must possess sufficient compressive strength, yet be fairly flexible.

[0048] As mentioned above, the inner catheter member **22** further includes the distal portion which has the stent **24** mounted thereto. The distal end of the inner catheter member **22** includes a stent holder **43** which is formed between a proximal abutting shoulder **42** and a distal abutting shoulder **44**. These shoulders create an area for mounting the self-expanding stent **24** in its collapsed position. These shoulders **42** and **44** also help to maintain the stent on the stent holder of the inner catheter member **22** as the outer restraining member **26** is retracted. The proximal shoulder **42** provides an abutting surface which contacts the end of the stent in the event frictional forces act on the stent as the outer restraining member **26** is being retracted. A distal marker **46** made from a highly radiopaque material, such as tantalum or a platinum iridium alloy (Pt/IR 90% / 10%), provides a visual reference point for the physician when utilizing fluoroscope or other imaging equipment. The shoulder **42** also can be made from a highly radiopaque material to serve as a visual marker as well. A soft tip **48** is attached to the inner catheter member **22** in order to create an atraumatic tip to help prevent snow plowing of the catheter portion as it is being delivered in an over-the-wire fashion along a guide wire. For example, the soft tip **48** can be made from a polymeric material such as polyether-block co-polyamide polymer sold under the trademark PEBAX 25b-barium sulfate, a soft material which includes a radiopaque element that provides an additional visualization point for the physician during fluoroscopy.

[0049] A guide wire lumen **50** extends along the entire length of the inner catheter member **22** and can be made from a tri-layer of materials such as PEBAX 72D, primacore and HDPE. The guide wire lumen **50** extends through the soft tip **48** and is attached to a luer fitting **52** mounted within a recess formed in the control handle **12**. The luer fitting **52** permits the control handle to be attached to syringes used to flush the system and also provides an opening for the guide wire. The luer fitting **52** is attached at the proximal end of the hypotube and fits within the recess formed in the control



handle to prevent the inner catheter member **22** from moving relative to the outer restraining member **26** during stent deployment. The luer fitting **52** can be attached to the hypotube **40** by gluing the fitting and hypotube together using a suitable adhesive. It should be appreciated that the mounting of the inner catheter member **22** to the control handle **12** can be achieved in any number of ways without departing from the spirit and scope of the present invention.

[0050] This guide wire lumen **50** can be made from other materials which provide a low friction interface between the delivery catheter and the guide wire which is used in the procedure to advance the catheter portion to the target site using over-the-wire techniques that are well known in the art. For example, the guide wire lumen can be made from tubing which is compatible with a 0.014 inch guide wire for an over-the-wire configuration.

[0051] The guide wire lumen **50** extends from the distal end of the inner catheter member **22** to the proximal end to allow a guide wire to be used to advance the catheter portion **14** (with mounted stent **24**) to the target area in the body lumen in an "over the wire" technique. In this regard, the catheter portion **14** can be introduced within the patient's vasculature using, for example, a conventional Seldinger technique through a guiding catheter. As will be addressed below, the guide wire lumen can also be made in a rapid exchange (Rx) platform which shortens the length of the guide wire lumen **50** to allow faster placement and delivery on the guide wire.

[0052] The outer surface of the inner catheter member can be coated with a silicone lubricant such as Microgilde manufactured by Advanced Cardiovascular Systems, Inc., Santa Clara, Calif., to further reduce the amount of frictional buildup between the outer restraining member and inner catheter member. Alternatively, the surface of the inner catheter and the outer sheath can be treated or formed in a shape that reduces the amount of surface contact between sliding components, thus reducing frictional buildup.

[0053] In one embodiment of the present invention, the outer restraining member **26** is a composite structure formed from three different sized tubing materials, each tubing material having a specific function. The outer restraining member **26** is shown including a proximal portion **54** which extends within the control handle **12** and is attached to the mechanism which produces the retraction force needed to retract the outer restraining member from the stent. This proximal portion **54** of the outer restraining member **26** is designed to move axially (along the longitudinal axis of the control handle). This proximal portion **54** of the outer member can be made from a material such as a polyimide. The outer restraining member **26** also includes a mid-portion **56** which can also be made from a material such as a polyimide or other similar material which provide a low profile, yet is strong enough to develop the pushability needed as the delivery system is moved along the guide wire in an over-the-wire delivery. This mid-portion **56** can be made with tubing having a different wall thickness than the proximal portion **54**. The outer restraining member **26** also includes a distal portion **58** which has a larger inner diameter than the tubing forming the mid-portion **56** in order to obtain the necessary diameter to maintain the collapsed self-expanding stent **24** in position on the system. This portion of the outer restraining member **26** is designed to hold the stent

**24** in its compressed or collapsed state and is retracted by actuating the thumbwheel **18** of the control handle **12** which proximally moves the restraining member while maintaining the inner catheter member **22** stationary during stent deployment. The distal portion **58** can be made from a material such as polyimide or other suitable materials which will provide the necessary restraining force needed to keep the self-expanding stent in place. Since it is usually desired to have a low profile at this distal location of the catheter, a tubing having a thinner wall thickness can be utilized.

[0054] Alternative material for forming the outer restraining member **26** includes material such as cross-linked HDPE. Alternative materials for the distal portion **58** include materials such as polyolefin which can be bonded to the mid-portion **56** of the outer restraining member **26**. A material such as polyolefin is used since it has sufficient strength to hold the compressed stent and has relatively low frictional characteristics to minimize any friction between the stent and the tubing. Friction can be further reduced by applying a coat of silicone lubricant, such as Microgilde, to the inside surface of the distal portion **58** before the stent is loaded onto the stent holder. Again, as mentioned above, the frictional buildup also can be reduced by treating or forming the surface of these components in a manner that reduces the amount of surface contact.

[0055] The outer sheath **28** extends along a portion of the length of the outer restraining member **26** as is necessary to create the conduit for the length of the catheter which remains outside the patient. The length of this outer sheath **28** can be varied depending upon the size of the medical device mounted on the distal end of the inner catheter member **22**. In this regard, the length of the outer sheath **28** generally can be as long as, or longer than, the guide catheter (not shown) utilized when the delivery system is placed in the patient's vasculature.

[0056] In one aspect of the invention, the outer sheath **28** includes the neck-down region **29** in which the inner diameter of the outer sheath **28** is comparable to the outer diameter of the mid-portion **56** of the outer restraining member **26**. In this fashion, a fairly tight fit extends between these two catheter portions in order to minimize blood loss between these catheter portions. Since the distal portion **58** has a larger diameter than the tubing forming the mid-portion **56**, the distal end of the outer sheath **28** should generally terminate a sufficient distance to allow the outer restraining member **26** to be fully retracted by the control handle **12**, while preventing the larger diameter distal portion **58** from abutting the distal end of the outer sheath **28**. In this regard, for example, if a 40 mm stent is mounted on the inner catheter member **22**, then the length of the retraction needed to properly release the device would require that the distal end of the outer sheath **28** be at least 40 mm away from the transition portion where the mid-portion **56** translates to the distal portion **58** to allow the outer restraining member **26** to retract properly. If a longer length medical device is mounted on the inner catheter member **22** then the overall length of the outer sheath **28**, of course, should be adjusted. It is also possible for the inner diameter of the outer sheath **28** to be at least as large as the outer diameter of the distal portion **58** of the outer restraining sheath **26** to allow proper retraction of the outer restraining sheath **26**.

[0057] The outer sheath **28** can be made from materials such as polyimide and other suitable materials. Other mate-



rials include polyetheretherketone (PEEK) and polyether-block co-polyamide polymer sold under the trademark purple PEBAX SA2032476. The strain relief 30 which is attached to the proximal end of the outer sheath can be made from a material such as Pebex 70D. As will be described in greater detail below, the strain relief 30 includes a proximal end 60 which can be threaded into the nose cone 32 of the control handle 12 to allow the physician to remove the outer sheath 28, if not needed.

[0058] Referring now to FIG. 7, the proximal end 60 of the strain relief 30 is shown in greater detail. As can be seen from this figure, the proximal end 60 includes a continuous channel 62 which creates a maze-like thread that allows the strain relief 30 to be removably attached to the control handle 12. This maze-like channel threads into the nose cone 32 and allows the outer sheath 28 to be connected or detached based upon physician preference. Referring specifically now to FIGS. 4 and 6, the channel 62 of the proximal end 60 is adapted to be threaded along a tab-like projection 64 which extends into the recess of nose cone 32 of the control handle 12. This tab-like projection 64 can be sized or shaped to fit within the channel 62. A projection stop element 66, which extends within this channel 62, acts like a detent once the proximal end 60 of the strain relief 32 has been threaded into the nose cone. This projecting stop 66 prevents the strain relief from being moved from the nose cone until the physician desires to remove the outer sheath from the control handle. In this manner, the area 68 adjacent to the projecting stop 66 is designed to contain the tab-like projection 64 until the physician is ready to remove the outer sheath. The physician can remove the outer sheath 28 by simply twisting the strain relief 32 to allow the tab-like projection 64 to move past the projecting stop element 66 and then be moved along the channel 62 until the projection 64 disengages from the channel. It should be appreciated that other coupling means could be formed or attached to the control handle, besides a tab-like projection 64, to receive the channel 62. Additionally, the outer sheath 28 does not have to be attached to the strain relief 30, but can be removably attached to the control handle itself. In this regard, the proximal end of the outer sheath can have a similar channel formed therein as is shown in FIG. 7.

[0059] The control handle 12 of the present delivery system 10 will be described in greater detail herein. Referring now specifically to FIGS. 4-6, a cross sectional view of the actuating mechanism housed within the control handle 12 is shown. The thumbwheel 18 of the control handle 12 is connected to the actuating mechanism which is adapted to retract the outer restraining member 26 relative to the inner catheter member 22 to allow the distal portion 58 of the outer restraining member to retract from the stent and cause it to self-expand into the target area. The actuator mechanism includes a slideable gear rack 70 which is disposed within a channel 72 formed along the length of the control handle 12. The slideable gear rack 70 is in turn attached to a spur gear 74 which engages the gears 76 on the gear rack 70. The thumbwheel 18 is connected directly to an actuating gear 78 which rotates as the thumbwheel is rotated by the physician. In this regard, once the thumbwheel 18 is rotated, the spur gear 74 is rotated by the actuating gear 78 causing the gear rack 70 to move proximally within the channel 72 formed in the control handle. FIG. 6 depicts the gear rack 70 in a position in which the gear rack 70 has been somewhat retracted through the rotation of the thumbwheel 18. Since

the delivery system 10 can be used with just one hand, the physician's other hand is free to perform other tasks, such as stabilizing the guiding catheter used during the procedure. By stabilizing the guiding catheter as well, enhanced accuracy in deploying the stent can be obtained

[0060] A lock mechanism 20, as shown in FIGS. 4 and 5, extends into the control handle to prevent the gear rack 70 from moving until the physician is ready to deploy the stent. In this regard, the lock mechanism 20 includes a locking arm 80 which is designed to abut against a stop element 82 formed or attached to the gear rack 70. As can be seen in FIG. 5, the locking arm 80 is shown in an abutting relationship with the stop element 82 to prevent the gear rack 70 from moving proximally in order to prevent retraction of the outer restraining member 26. The lock mechanism 20 includes a cam-like spring 84 designed to slide along a surface 86 formed into the body of the control handle 12. When the lock mechanism 20 is moved proximally by the physician, the locking arm 80 moves upward and away from the stop element 82 to permit the stop element 82 to move past it. It should be appreciated that this is just one mechanism which can be utilized to prevent unwanted retraction of the outer restraining member 26.

[0061] A spring 88 is mounted on a tab or protrusion 90 formed on the body of the control handle 12. This spring 88 is designed to contact the distal surface 91 of the gears 76 forming the gear rack 70 to prevent the gear rack 70 from moving distally at any time. As a result, the control handle 12 of the present invention is capable of moving the outer restraining member in one direction, namely proximally. In this regard, the spring 88 allows the control handle to store energy and prevents the physician from losing energy during deployment. The spring 88 accomplishes this by creating an abutting edge 89 which contacts the distal surface 91 of the gears 76, as is shown in FIG. 5, preventing the gears 76 from moving distally, but allowing movement of the gear rack 70 in a proximal direction. The spring 88 could alternatively be placed in an abutting arrangement with one of the gears of the other moveable components forming the retraction mechanism. For example, the spring 88 could be placed near and in contact with the spur gear or actuating gear in order to allow rotation in only one direction. It should be appreciated to those skilled in the art that still other ways of restricting movement of the gear rack and outer restraining member could be implemented without departing from the spirit and the scope of the present invention.

[0062] The delivery system of the present invention also includes a flushing system used to evacuate air from the system. It is important to evacuate air from the system when the delivery system is being used in a patient's vasculature since air bubbles can sometimes cause damage to vital organs. In other instances, it may be desirable to have a fluid pre-placed into the system to prevent the possible accumulation of blood between the outer restraining member and the inner catheter member since stagnated blood has the tendency to coagulate and cause thrombosis. An alternative flushing fluid besides saline could be an anti-clotting agent which can be placed in the annular space formed between the outer restraining member and the inner catheter member to minimize blood clotting. Such an anti-clotting agent includes heparin, which not only provides an anti-clotting factor, but also includes smooth deployment and reduces deployment forces. Additionally, if blood clots in the annular



space, it would lead to higher deployment forces, non-deployments, and potentially partial deployments. An anti-clotting agent, such as heparin, also can be placed in the annular space formed between the outer sheath and the outer restraining member to prevent clotting of blood within this space as well. It should be appreciated other anti-clotting agents besides heparin could be utilized in the same fashion. For these reasons, it may be beneficial to pre-flush the system before placing the delivery catheter in the patient.

[0063] Referring now to FIG. 2, the flushing system consists of an opening 92 or several openings extending through the inner catheter member 22 in the area of where the distal portion 58 meets the mid-portion 56 of the outer restraining member 26. The openings are drilled through to the guide wire lumen 50 to effectively open up a passageway from the guide wire lumen to the annular space formed between the inner catheter member 22 and the outer restraining member 26. A syringe can be attached to the luer fitting 52 on the catheter handle 12 and sterile fluid can be pumped into the guide wire lumen 50 in order to flush air from the system. A mandrel (not shown) can be placed in the guide wire lumen at the tip 48 to block the flow of the sterile fluid through the distal tip. The sterile fluid is thus forced to flow out of the small openings 92 into the annular space formed between the inner catheter member and outer restraining member. The fluid eventually flows past the collapsed stent where the fluid and any air in the system will escape through the distal opening of the outer restraining member 26. Once fluid is observed dripping from the distal end of the outer restraining member 26, the mandrel can be removed since air has been evacuated from the system. Since the gap sizes are so small between the various components, capillary force prevents air from infiltrating the delivery system once the evacuation has been completed.

[0064] The components of the control handle can be made from conventional materials well-known in the medical manufacturing art. For example, the control handle can be made from a plastic or plastic-like material such as ABS plastic, as can the various other components including the locking mechanism, gears and gear rack.

[0065] Referring now to FIGS. 8-10, an Rx version of the delivery system is disclosed. In this embodiment of the present invention, the catheter portion of the system is essentially identical to the catheter portion of system depicted in FIGS. 1-3 and, accordingly, like numerals are used to identify like components. The control handle 12 is shown schematically in FIG. 8. It should be appreciated that any type of control handle can be utilized in conjunction with the catheter portion shown in FIGS. 8-10, including, of course, the particular embodiment of the control handle disclosed in FIGS. 4-7.

[0066] As can be seen in these figures, the outer sheath 28 includes an exit opening 94 through which the guide wire 51 exits. Likewise, the outer retaining member 26 includes an exit opening 96 formed proximal to the distal portion 58 of the member 26 which is adapted to maintain the stent 24 in its collapsed position on the inner member 22. The inner member 22 also includes an exit opening 98 through which the guide wire 51 slides there-through. In this regard, the guide wire lumen 50 extends only a short length compared to the longer guide wire lumen 50 shown in the embodiment of FIGS. 1-7. The shorter guide wire lumen 30 allows

greater ease in placing the catheter portion on the guide wire and, additionally, increases the speed in advancing the distal end of the catheter portion along the guide wire and into the area of treatment.

[0067] Referring specifically now to FIG. 9, the position of the outer sheath 28 relative to the distal portion 58 of the outer restraining member 26 is shown. The exit opening 94 formed on the outer sheath 28 should be fixed a certain distance away from the edge of the distal opening 56 formed on the outer restraining member 26. In FIG. 9, this distance X1 is represented by arrows. In practice, the distance X1 should be sufficiently long to allow the distal portion 58 to be fully retracted from the stent. In the event that the distance X1 is too short, there is a possibility that the distal end of the outer sheath 28 could abut against the distal portion 58 before the distal portion 58 is fully retracted from the stent. Likewise, distance X2 represented by arrows in FIG. 9 should be essentially the same as distance X1 so that when the outer restraining member 26 is retracted proximally, the position of the guide wire 51 will be maintained. Exit opening 98 formed on the inner member 22 should be sufficiently long in length to prevent the guide wire 51 from bunching or becoming pinched between the two exit openings 96 and 98. The length of the exit openings also can be adjusted accordingly to allow the guide wire to be maintained in place even as the outer restraining member 26 is being retracted.

[0068] As can be seen best in FIG. 10, the diameter of the outer sheath 28 should be large enough to create a passage between the sheath 28 and restraining member 26 which is large enough to allow the guide wire 51 to pass through. Otherwise, it is possible for the guide wire 51 to be moved, along with the restraining member 26, as the restraining member 26 is being retracted during usage. It should be appreciated that the particular embodiment of a Rx platform disclosed in FIGS. 8-10 is just one of a number of different Rx designs which can be utilized in accordance with the present invention.

[0069] Turning now to FIGS. 1-17, another aspect of the present invention can be described. In these figures, portions of two tubular members are depicted schematically to represent the various ways that one or more of the outer surfaces of the tubular members can be treated or formed in order to minimize surface contact. As previously mentioned, a reduction of surface contact usually reduces the amount of frictional forces developed as the tubular members slide relative to each other. Referring initially to FIGS. 11 and 12, a cross-section of view of a portion of an inner member 100 is shown co-axially disposed within an outer tubular member 102. The inner tubular member 100 includes an outer surface 104 having a roughened surface which contacts the inner surface 106 of the outer tubular member 102. Since the roughened surface of the outer surface of the inner tubular member 100 is formed with multiple "ridges" or raised projections which extend above the remaining surface, the actual amount of surface contact made between the two components is decreased, allowing the two tubular members to slide more freely. As a result, the amount of force required to move the inner tubular member 100 relative to the outer tubular member 102 should be reduced.

[0070] Referring specifically now to FIGS. 13 and 14, the inner tubular member 100 is shown having a substantially



smooth outer surface **104**. However, the prior tubular number **102** has an inner surface including a roughened surface which again reduces or minimizes the amount of surface contact made between the two components. As a result, the roughened surface of the inner surface of the outer number **102** again helps to reduce both static friction and dynamic friction between the two components.

[0071] FIG. **15** shows a schematic representation of the scoring that can be utilized in order to attain the roughened surface of the tubular number **100**. The lines **108** shown in FIG. **15** are depicted somewhat uniform, however, in most instances, the roughing or scoring of the surface will be non-uniform and will result in ridges or raised projections which are non-uniform in size and depth. The roughened surfaces depicted in FIGS. **11-15** also show a somewhat wavy pattern which represents the ridges or raised projections. It shall be appreciated that this is more of a schematic representation of a roughened surface as well.

[0072] The surface of the tubular number **100** can be treated after the tubular number has been manufactured utilizing equipment which will cut into the surface to create the ridges or projections. For example, a “knurling” fixture having a pair of metal wheels that have roughened surfaces can be utilized to create the ridges or projections. In this regard, the tubular member can be placed between the pair of wheels and pulled to cause the wheels to plastically deform the tubular number to form the small ridges and/or projections on the outer surface of the member. It should be appreciated that there are many other different ways to plastically deform the surface of the tubular member in accordance with the present invention.

[0073] In another aspect of the present invention, surface contact between the tubular member can be reduced by forming multiple ridges or upward projections directly when the tubing is actually formed. For example, if the tubular member is formed from thermoplastic material, then the tubular member can be extruded such that the inner surface and/or the outer surface can be extruded to have a non-circular cross-section. If the tubular member is made from a thermostat material, for example, and it could be manufactured such that the mandrel or die utilized in the process can form the non-circular cross-sectional area. Several embodiments which depict non-circular cross-sectional areas of tubular members are disclosed in FIGS. **16** and **17**. As can be seen from the cross-sectional view of FIG. **16**, the inner member **100** is shown having a non-circular cross-sectional area which includes a number of apices **110** (or ridges) formed on the outer surface **104** which come in contact with the inner surface **106** of the outer member **102**. This is just one particular cross-sectional design that can be utilized in accordance with the present invention. As also can be seen in FIG. **16**, the outer tubular number **102** includes a roughened outer surface **112** which allows another tubular number to be disposed over it to reduce surface contact which again reduces surface friction.

[0074] Referring now to FIG. **17**, another particular embodiment of the outer tubular member **102** is shown having a non-uniform cross-sectional area which includes a hexagon shape that reduces the amount of surface contact between its inner surface **106** and the outer surface **104** of the inner member **100**. The outer surface of the outer tubular member can include a roughened surface **112** or can be

extruded into a non-circular shape which allows another tubular member to be coaxially disposed over the second tubular member.

[0075] In context with the present invention, the various treated surfaces and formed surfaces of the tubular members depicted in FIGS. **11-17** can be utilized in conjunction with the inner member **22**, the outer restraining member **26** and the outer sheath **28**. A number of different combinations of contact surfaces can be achieved. It should be appreciated that there are numerous shapes that could be utilized when extruding the tubular members in order to minimize surface contact. Moreover, the surfaces can be roughened using a variety of abrasion or surface cutting techniques. Regardless of which techniques are used, the minimization of surface contact in the catheter portion of the present invention should result in a reduction in the frictional force required to move the tubular members in order to expose the self-expand stent. As a result, the retracting forces which must be generated by the control handle in moving the tubular members also can be reduced.

[0076] It is to be understood that even though numerous characteristics and advantages of the present invention have been set forth in specific description, together with details of the structure and function of the invention, the disclosure is illustrative only and changes may be made in detail, such as size, shape and arrangement of the various components of the present invention, without departing from the spirit and scope of the present invention. It would be appreciated to those skilled in the art that further modifications or improvement may additionally be made to the delivery system disclosed herein without departing from the scope of the invention. Accordingly, it is not intended that the invention be limited, except as by the appended claims.

**1-17.** (canceled)

**18.** A catheter system for delivering and deploying a medical device within a patient, the catheter system comprising:

an inner tubular member having a region for mounting the medical device thereon and a restraining member coaxially disposed over the inner tubular member and the medical device, the restraining member being adapted for axial movement with respect to the inner tubular member, wherein the inner tubular member and restraining member have an outer surface which is in sliding contact with each other and at least one of the outer surfaces is plastically deformed to create a treated surface having raised projections which decrease the amount of surface contact between the treated surface and the surface which is in sliding contact with the treated surface.

**19.** A catheter system for delivering and deploying a medical device within a patient, the catheter system comprising:

an inner tubular member having a region for mounting the medical device thereon and a restraining member coaxially disposed over the inner tubular member and the medical device, the restraining member being adapted for axial movement with respect to the inner tubular member, wherein the inner tubular member and restraining member have outer surfaces which come in sliding contact with each other, at least one of the surfaces having a formed outer surface having raised



projections which decrease the amount of surface contact between the formed surface and the surface in sliding contact with the formed surface.

20. The catheter system of claim 19, wherein the material forming the inner member and restraining member is a tubing which is extruded to a size and shape which includes the formed surface.

21. A catheter system, comprising:

an inner member, the inner member having an exterior profile; and

an outer sheath, the outer sheath including an interior sized and shaped to receive the inner member;

wherein the exterior profile of the inner member includes at least one raised portion configured to engage the interior of the outer sheath.

22. The catheter of claim 21, wherein the at least one raised portion engages the interior of the outer sheath thereby minimizing surface contact between the inner member and the interior of the outer sheath.

23. The catheter system of claim 22, wherein the inner member is generally tubular.

24. The catheter system of claim 23, wherein the exterior profile of the inner member includes a plurality of raised projections.

25. The catheter system of claim 24, wherein a cross section of the inner member defines a non-circular profile.

26. The catheter system of claim 25, wherein the non-circular profile is characterized by a hexagonal shape.

27. The catheter system of claim 25, wherein the non-circular profile is characterized by a star-like shape.

28. The catheter system of claim 27, wherein the non-circular profile includes at least five raised projections.

29. The catheter system of claim 22, wherein the inner member and outer sheath are configured to be translated longitudinally with respect to each other.

30. The catheter system of claim 29, further comprising a medical device configured between the inner member and the outer sheath.

31. The catheter system of claim 30, wherein the medical device is a self-expanding stent, the outer sheath maintaining the self-expanding stent in a compressed condition.

32. The catheter system of claim 29, further comprising a restraining sheath, the restraining sheath having a generally tubular body and being coaxially arranged about at least a portion of the outer sheath.

33. The catheter system of claim 32, wherein the inner catheter includes an inner lumen, a side wall and an exit opening configured through the side wall.

34. The catheter system of claim 33, wherein the outer sheath includes an exit port providing access to the interior of the outer sheath.

35. The catheter system of claim 34, wherein the restraining sheath includes a side opening formed in the generally tubular body of the restraining sheath.

36. The catheter system of claim 35, further comprising a guide wire, the guide wire being routed through the exit opening, the exit port and the side opening to thereby provide rapid exchange route for the guide wire.

\* \* \* \* \*