



US 20070042306A1

(19) **United States**

(12) **Patent Application Publication**
Bacon

(10) **Pub. No.: US 2007/0042306 A1**

(43) **Pub. Date: Feb. 22, 2007**

(54) **APPARATUS FOR IGNITING COMBUSTIBLE MEDIUMS**

Publication Classification

(76) Inventor: **David W. Bacon**, Paige, TX (US)

(51) **Int. Cl.**

F23G 7/08 (2006.01)

F23Q 11/00 (2006.01)

F23Q 9/00 (2006.01)

F23D 14/62 (2006.01)

Correspondence Address:

C. JAMES BUSHMAN

5718 WESTHEIMER

SUITE 1800

HOUSTON, TX 77057 (US)

(52) **U.S. Cl.** **431/268**; 431/202; 431/354;
431/350; 431/278

(21) Appl. No.: **10/574,611**

(57)

ABSTRACT

(22) PCT Filed: **Oct. 7, 2004**

(86) PCT No.: **PCT/US04/33140**

§ 371(c)(1),

(2), (4) Date: **Apr. 5, 2006**

An apparatus for initiating ignition of a combustible material, the apparatus including an igniter assembly having a support, a catalytic material carried by the support, the catalytic material comprising a substance which reacts with a hydrogen-containing gas in the presence of an oxidizing gas to produce an exothermic reaction and a temperature sufficient to cause auto ignition of the hydrogen containing gas, a source of hydrogen-containing gas and a source of oxidizing gas.

Related U.S. Application Data

(60) Provisional application No. 60/509,813, filed on Oct. 10, 2003.

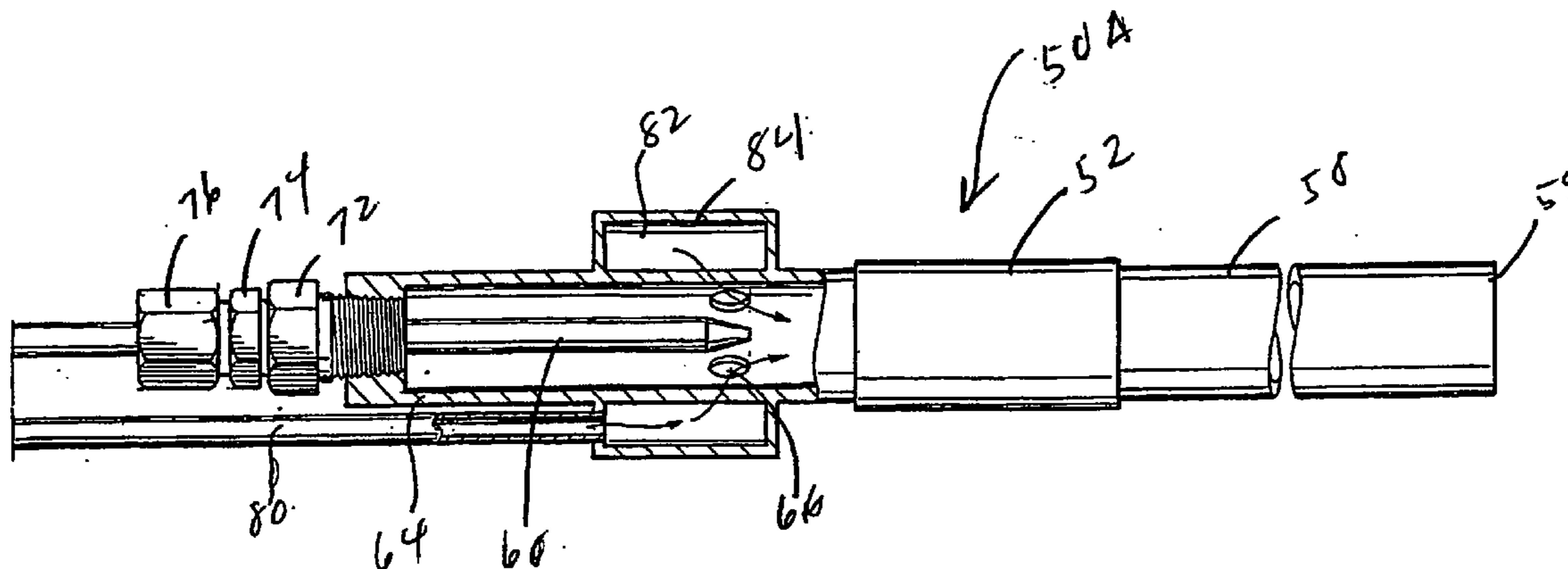

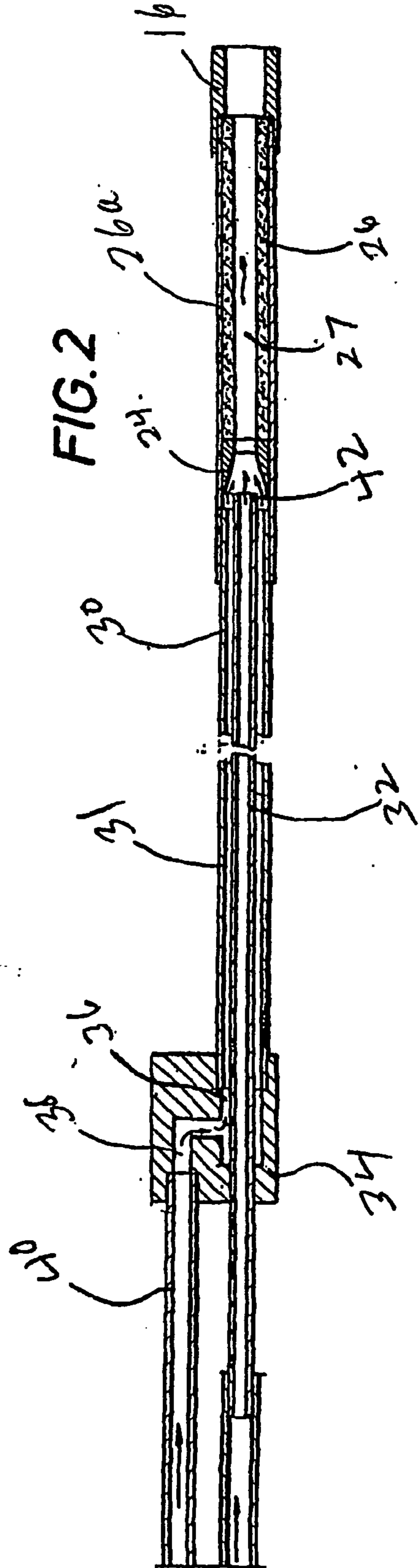
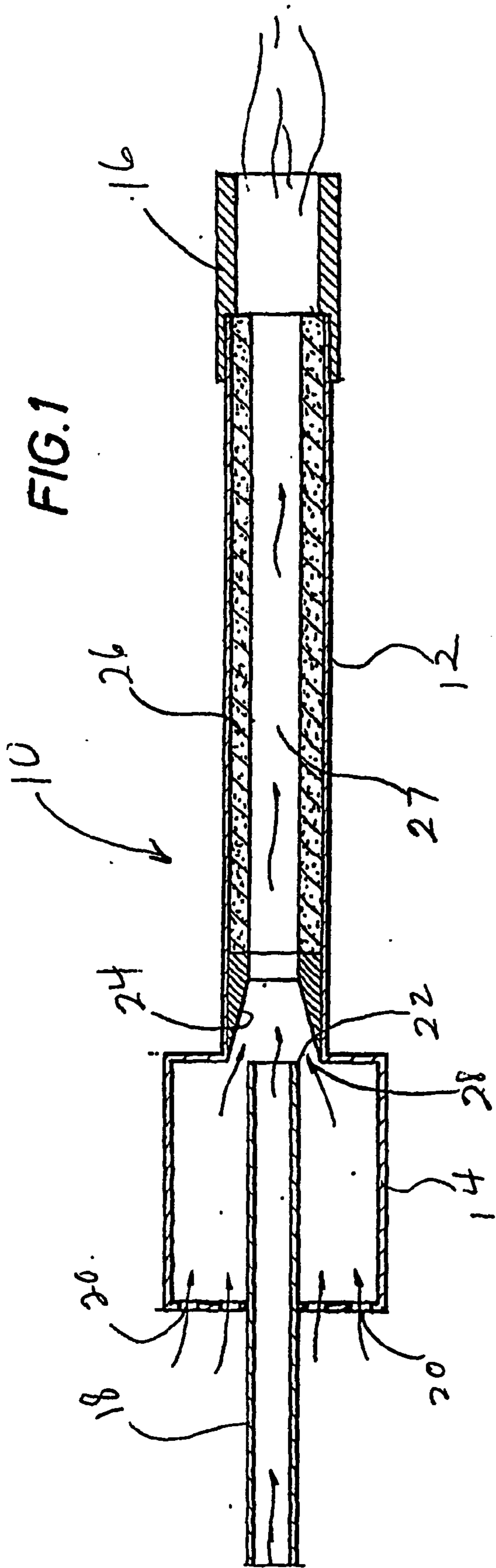

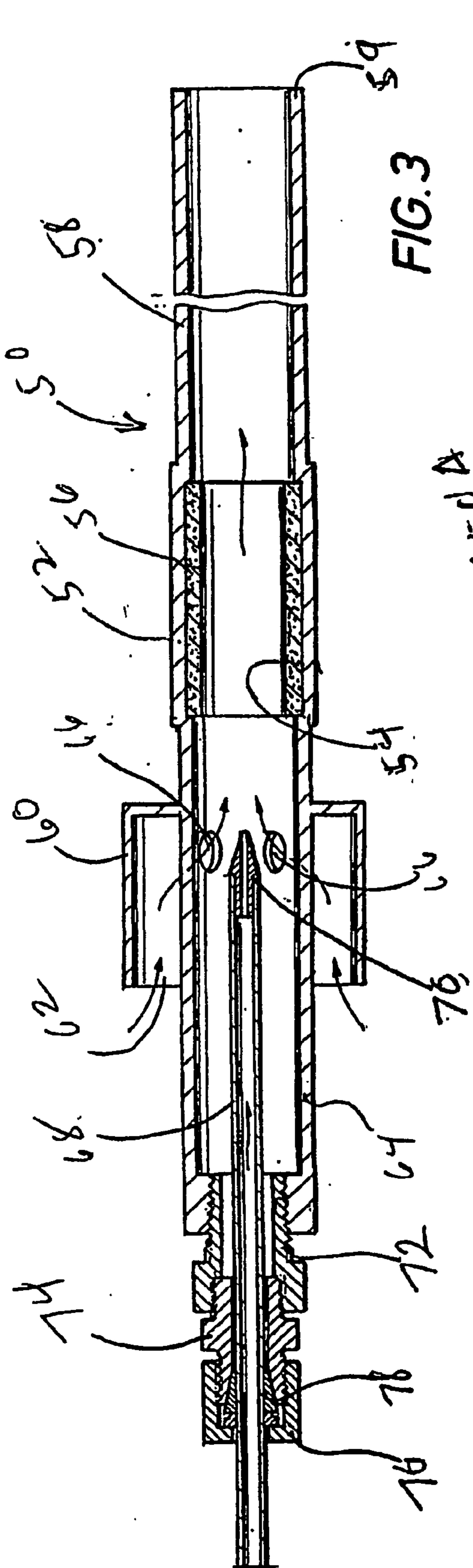

FIG. 3

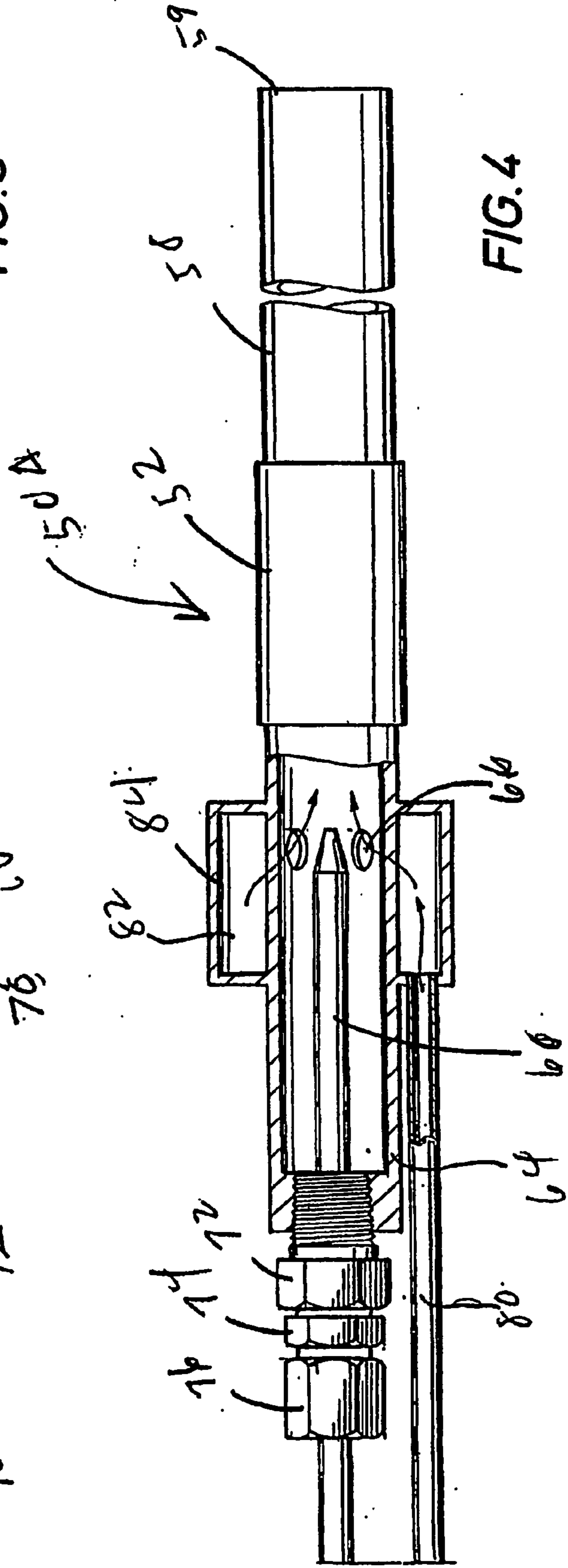
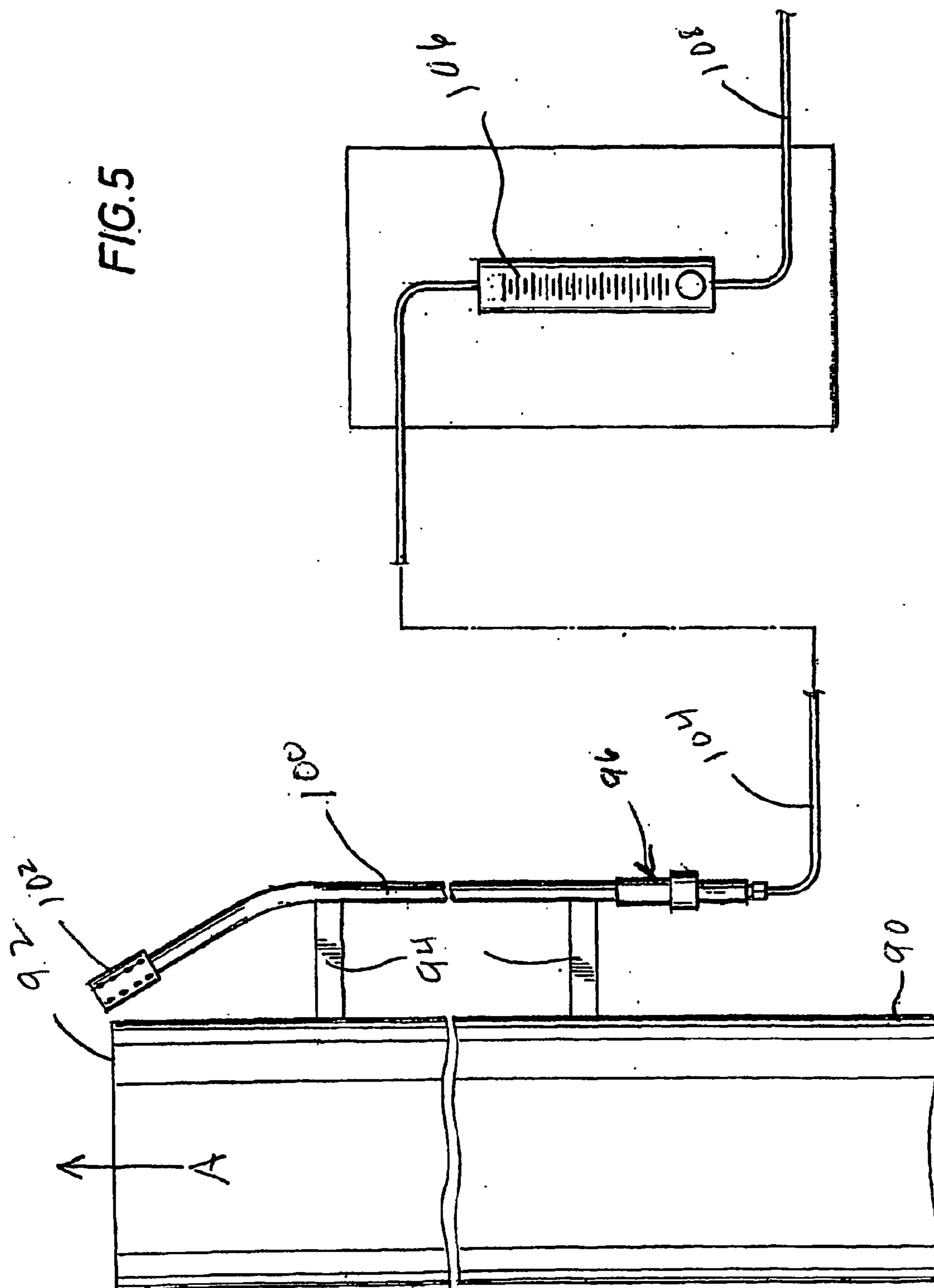
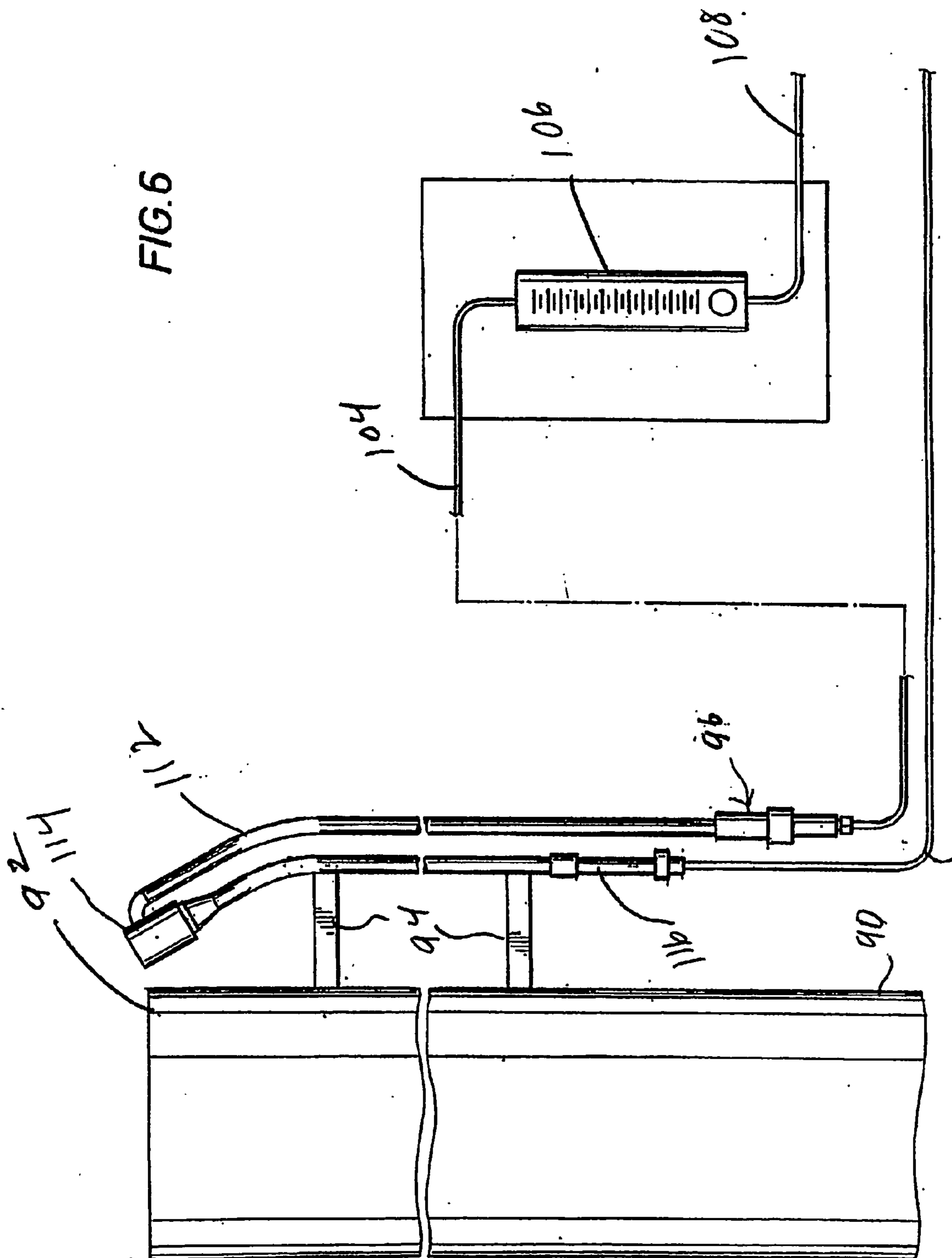
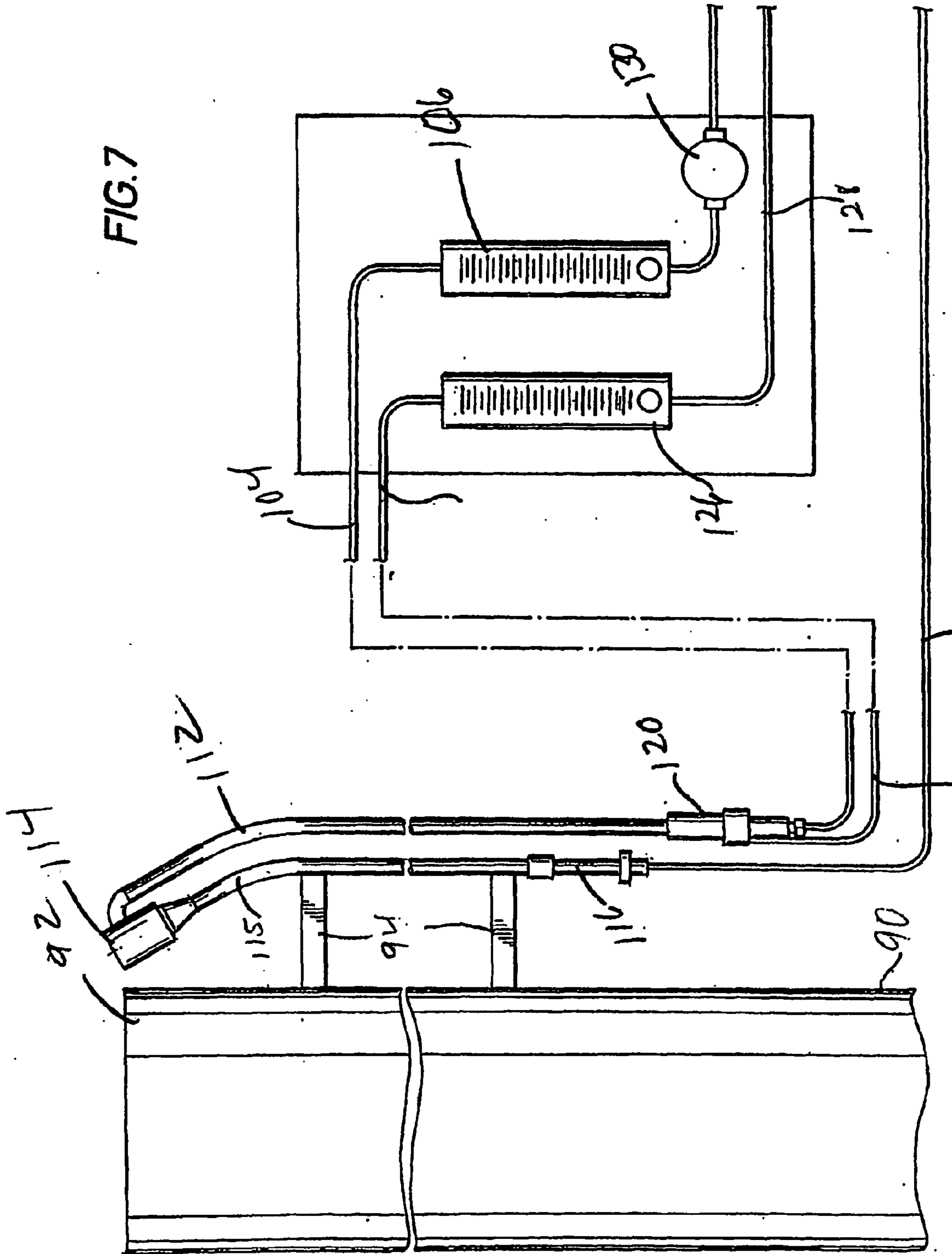

FIG. 4







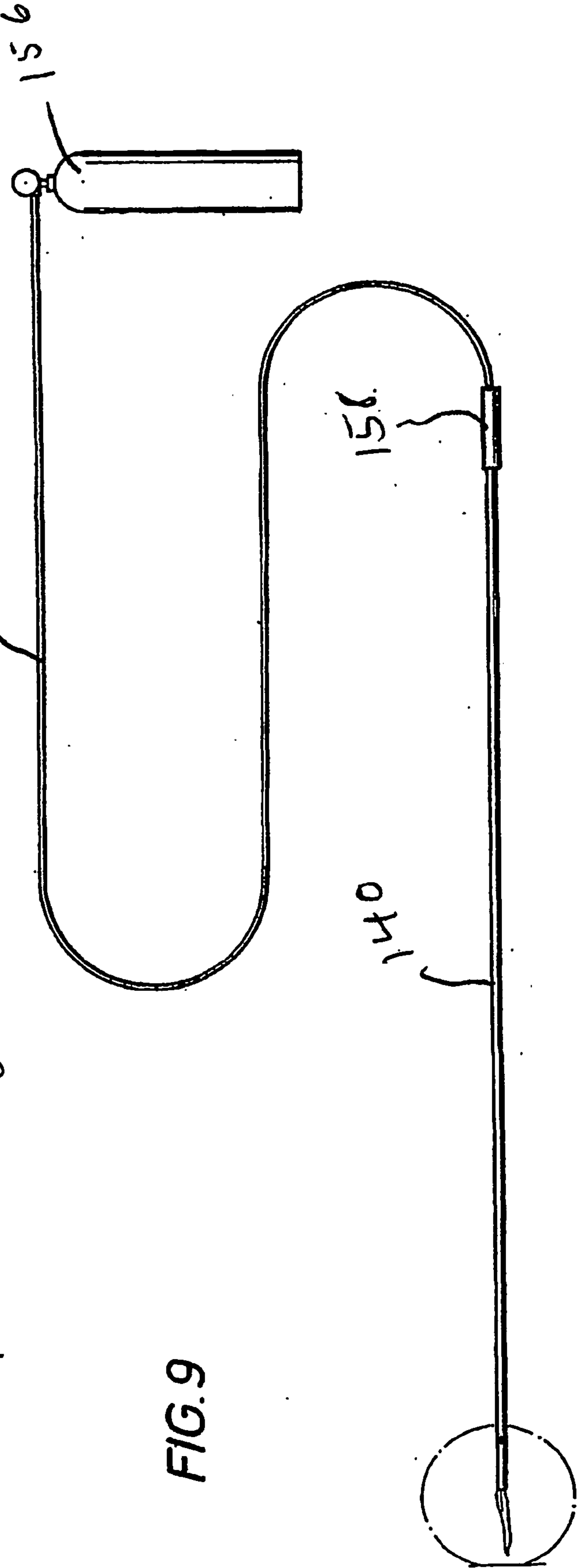
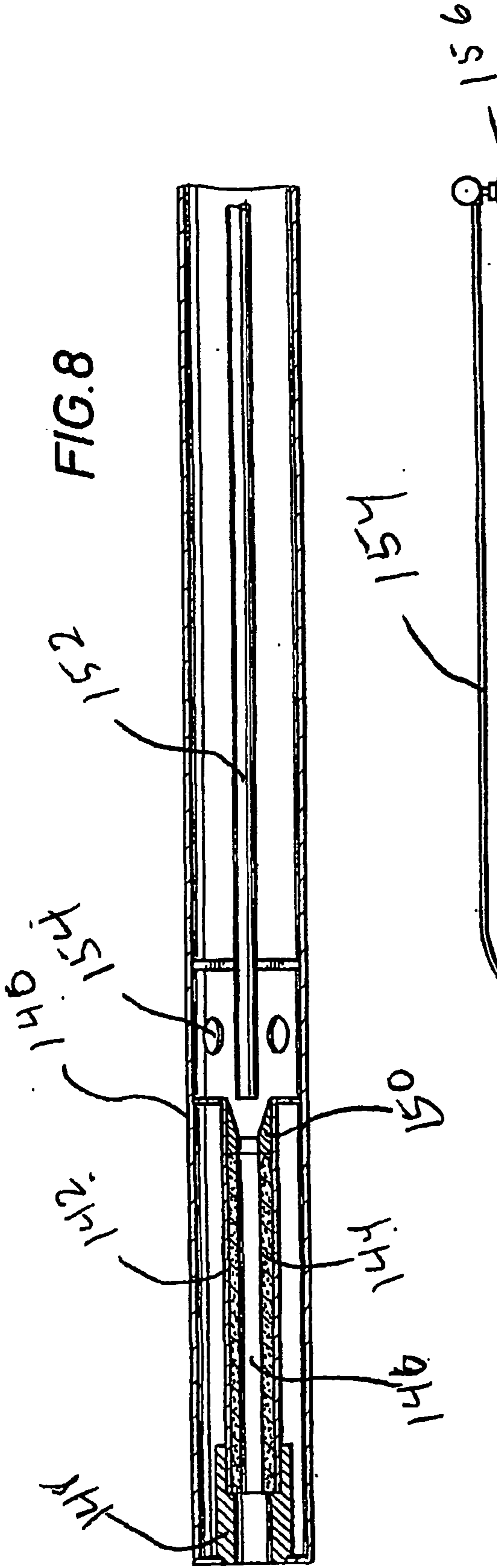
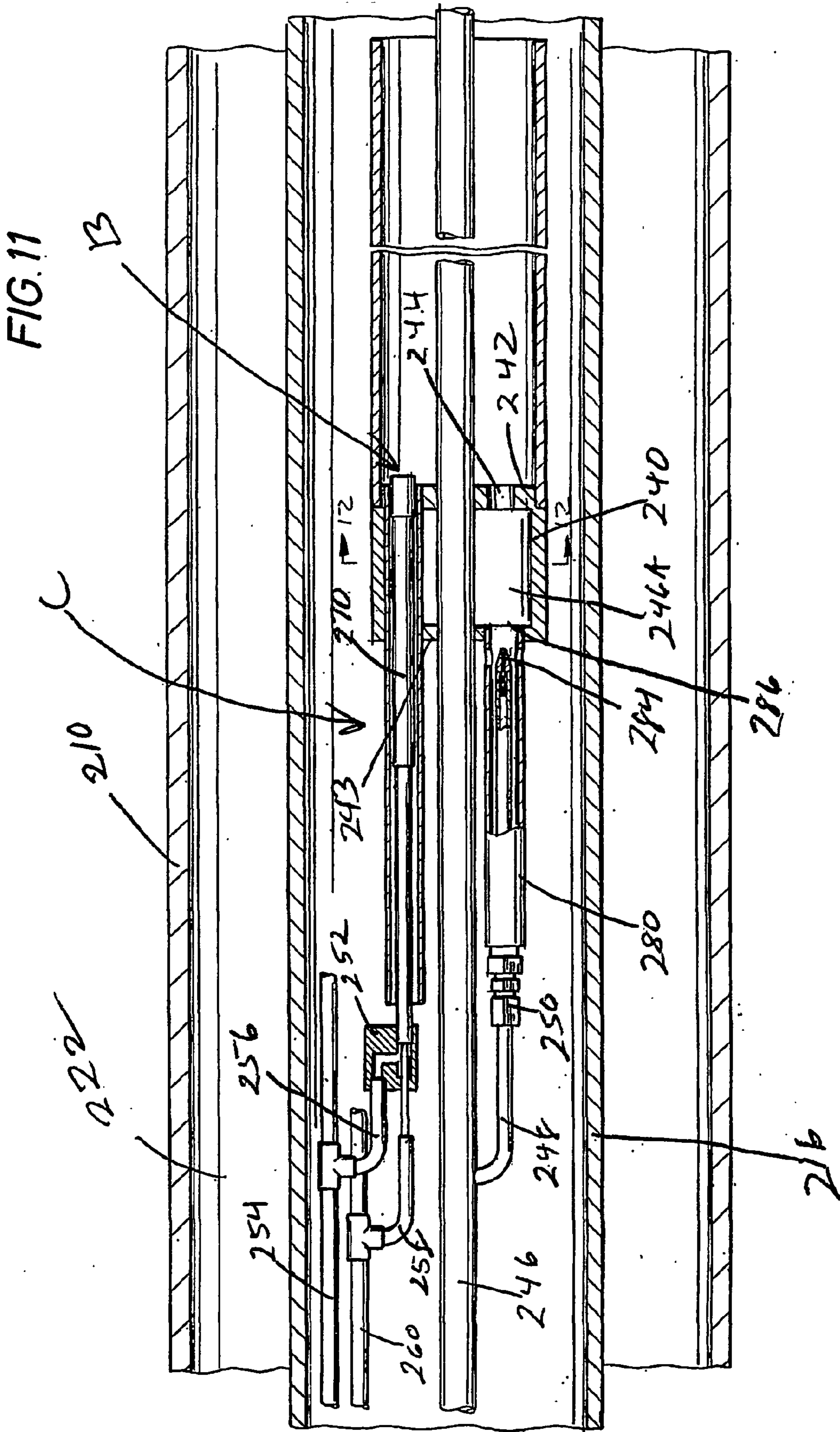
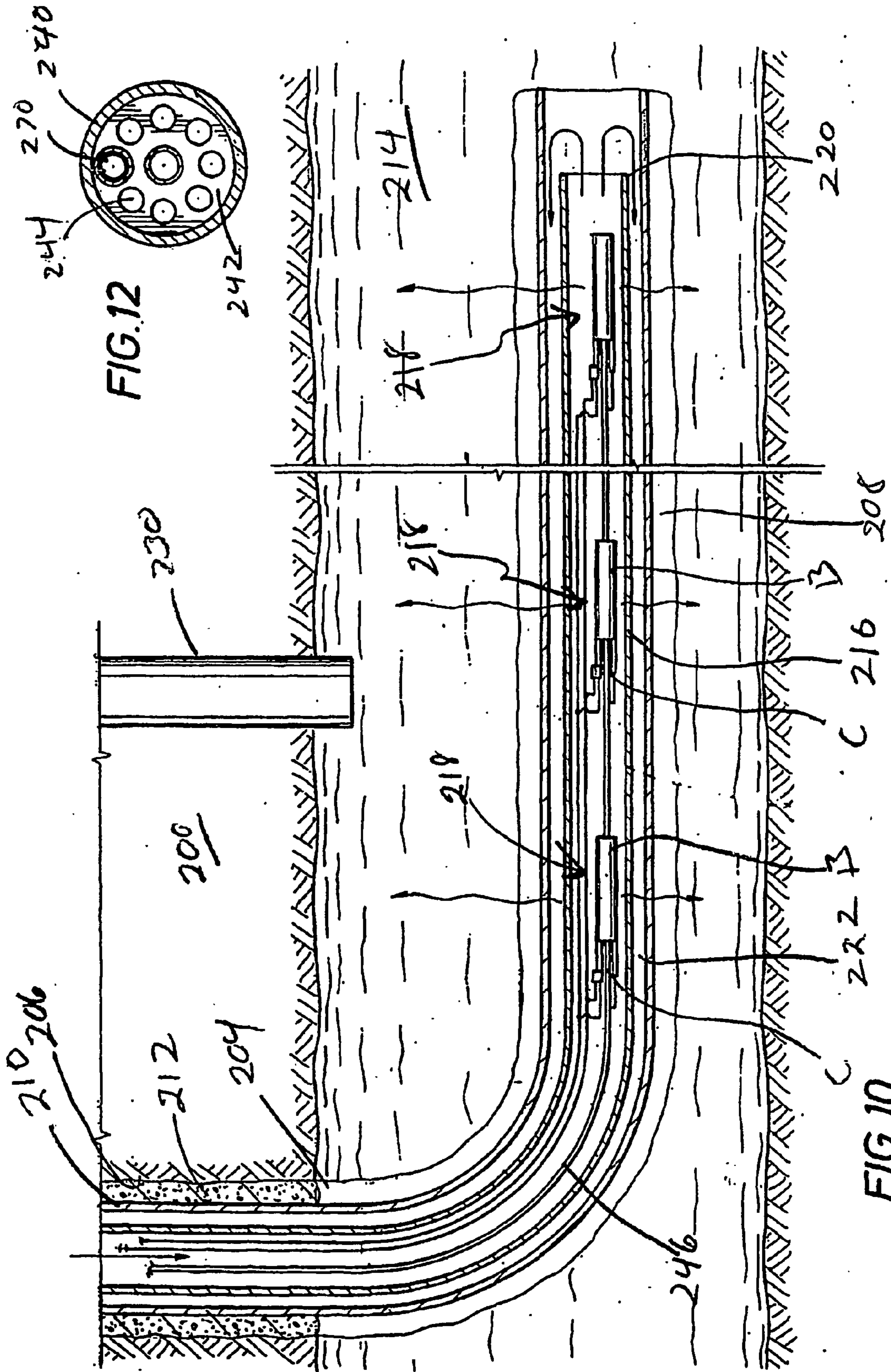

FIG. 9

FIG. 8





APPARATUS FOR IGNITING COMBUSTIBLE MEDIUMS

CROSS REFERENCE TO RELATED APPLICATION

[0001] This application claims priority from and incorporates herein U.S. Provisional Application No. 60/509,813 filed Oct. 10, 2003.

BACKGROUND OF THE INVENTION

[0002] 1. Field of the Invention

[0003] The present invention relates to ignition systems, particularly catalytic ignition systems. More particularly, the present invention relates to apparatuses employing such ignition systems that can be used in remote environments to ignite a combustible mixture, e.g., a hydrocarbon/oxygen gas containing mixture.

[0004] 2. Description of Prior Art

[0005] Ignition systems for igniting a combustible mixture at a remote location are used in a variety of applications. By way of example, such ignition systems can be used to ignite combustible mixtures issuing from flare stacks in refineries, chemical plants, etc. A prime example of the use of an ignition system in a remote environment is their use in igniting burners disposed in earth boreholes drilled into a subterranean formation. Generally, the subterranean formation is one that contains a hydrocarbonaceous material e.g., coal, shale, tar sands, oil, etc. For example, it has been proposed to drill one or more boreholes into a coal formation and then, by the generation of heat in the borehole, gasify the coal in the formation to result in the in situ generation of synthesis gas. United States Patent Application Publications U.S. 2003/0173081 ('081 Publication) and US 2003/0141065, both of which are incorporated herein by reference, describe methods and systems for the production of hydrocarbons, hydrogen and/or other products from various hydrocarbon-containing formations. In the '081 Publication, there is described the in situ conversion of hydrocarbons to produce more valuable hydrocarbons, hydrogen and/or novel product streams from underground oil containing formations. In the process proposed in the '081 Publication, one or more heat sources is installed into a subterranean, hydrocarbon (oil) containing formation to heat the formation, one of the goals being to raise the temperature in the formation above the pyrolyzation temperature of the hydrocarbons in the formation. The '081 Publication describes numerous embodiments and systems for supplying heat, preferably at pyrolysis temperatures, to the oil containing formation to vaporize and/or pyrolyze the oil and convert at least a portion of the oil to more valuable and more easily recoverable hydrocarbons, the produced more valuable hydrocarbons being recovered from the subterranean formation.

[0006] While a number of electrical heating elements have been proposed to heat subterranean formations, they all suffer from the inherent problems of requiring hard wiring to the surface as well as being expensive and lacking efficiency. To overcome some of these difficulties, it has been proposed to combust a fuel, the combustion gases being used as the heat source. In this regard, it has been proposed that the combustion may take place in the formation in a well, and/or

near or at the surface. For example, the combustion in the formation may be in the form of a fire-flood. An oxidizer may be pumped into the formation. The oxidizer may be ignited to advance a fire front towards the production well.

[0007] Flameless combustors may be used to combust the fuel within the well. Flameless combustors are demonstrated, for example, in U.S. Pat. Nos. 5,255,742, 5,404,952, 5,862,858, 5,899,269, and 6,269,882, all of which are incorporated herein by reference. Most of these flameless combustors operate by preheating a fuel and combusting it to a temperature above an auto ignition temperature of the mixture. The fuel and combustion air are then mixed in the heating zone to combust. In the heating zone, the flameless combustor, and a catalyst surface may be provided to lower the auto ignition temperature of the fuel and air mixture.

[0008] It clearly would be desirable to have an ignition source or system which could be positioned in the wellbore, e.g. in a tubing having an ID as small as 3" positioned in the wellbore, and which, without the use of electrical igniters or heaters, and without any preheating of a fuel and oxygen containing mixture, could ignite a fuel/oxygen gas containing mixture, the combustion gases from the fuel being used to heat an airstream being pumped into the tubing, the combined heated air and combustion gases then being used to heat the formation to the desired temperature e.g. the vaporization and/or pyrolysis temperature of at least a portion of the hydrocarbons in the formation.

SUMMARY OF THE INVENTION

[0009] In one preferred embodiment, the present invention can include an ignition system which can be positioned in a relatively small diameter tubing e.g. a 3" I.D. tubing, which is disposable in an earth borehole and which will ignite a combustible fuel e.g. a mixture of a hydrocarbon and an oxidizing gas, e.g., air, without the use of electrical heaters, preheating of gases, etc.

[0010] In another preferred embodiment, the present invention can employ a composition of matter which, when exposed to a first gas/oxygen containing gas (oxidizer) mixture, results in an exothermic reaction causing the temperature of the composition of the matter to be elevated above the auto ignition temperature of the first gas with consequent ignition of the first gas/oxidizer mixture to produce a pilot flame. The resulting pilot flame can be propagated into (1) a burner ignition zone to ignite a fuel mixture supplied to suitable burner(s), or (2) or near the opening in a flare stack from which is issuing a combustible medium to ignite the combustible mediums.

[0011] In another preferred embodiment of the present invention, there can be employed a series of ignition systems as described above in conjunction with a series of burners which can be spaced axially along the inside of a burner tubing positioned in an earth borehole so as to provide a multiplicity of heat generating sources along the length of the tubing. The hot combustion gases flowing towards the bottom of the tubing disposed in the wellbore can then exit the bottom of the tubing and flow up the annulus between the burner tubing and a second concentrically disposed tubular, e.g., casing, surrounding the burner tubing. Alternatively, the hot combustion gases can flow into the annulus between the burner tubing and the formation in the case of an open, uncased borehole. Additionally, air from the surface can be

pumped down through the burner tubing, the air being heated by the combustion gases and/or the flame from the burners.

[0012] Yet another preferred aspect of the present invention can include an igniter/burner module wherein an igniter system, as described above, is mounted, on, in or in sufficiently close proximity to a burner that is supplied with a combustible fuel. The burner may take the form of one or more nozzles, jets or openings in a burner block or housing, the burner being supplied with a combustible fuel mixture, the igniter system being positioned sufficiently close to at least one nozzle so that it will ignite the combustible fuel mixture issuing from the nozzle and subsequently all other nozzles.

[0013] Still a further preferred aspect of the present invention can include an apparatus for igniting a combustible medium issuing from an opening in a flare stack, the apparatus including an igniter assembly having a support, a catalytic material carried by the support, the catalytic material comprising a substance which reacts with a hydrogen containing gas in the presence of an oxidizing gas to produce an exothermic reaction and preferably a temperature sufficient to cause auto ignition of the hydrogen, a source of the hydrogen-containing gas and a source of the oxidizing gas. There is a mount for positioning the igniter assembly adjacent the opening in the flare stack from which the combustible medium is issuing.

BRIEF DESCRIPTION OF THE DRAWINGS

[0014] FIG. 1 is an elevational, sectional view of one embodiment of an igniter assembly used in the apparatus of the present invention.

[0015] FIG. 2 is an elevational, sectional view of another embodiment of the igniter assembly used in the apparatus of the present invention.

[0016] FIG. 3 is an elevational, sectional view of another embodiment of the igniter assembly used in the apparatus of the present invention.

[0017] FIG. 4 is an elevational view, partly in section of another embodiment of the igniter assembly used in the apparatus of the present invention.

[0018] FIG. 5 is an elevational view of an igniter assembly in accordance with one embodiment of the present invention used with a flare stack.

[0019] FIG. 6 is an elevational view of another embodiment of the igniter assembly of the present invention used with a flare stack.

[0020] FIG. 7 is an elevational view of another embodiment of the igniter assembly of the present invention used with a flare stack.

[0021] FIG. 8 is an elevational view, partly in section of a portion of an igniter wand employing an igniter assembly in accordance with the present invention.

[0022] FIG. 9 is an elevational view showing the igniter wand as connected to the source of a hydrogen-containing gas.

[0023] FIG. 10 is an elevational view, partly in section, showing a plurality of igniter assembly/burner modules in a

tubing in a earth borehole which is in a subterranean formation containing hydrocarbonaceous materials.

[0024] FIG. 11 is an elevational view, partly in section, showing in greater detail the igniter assembly/burner module shown in FIG. 10.

[0025] FIG. 12 is a cross-sectional view taken along the lines 12-12 of FIG. 11.

DESCRIPTION OF PREFERRED EMBODIMENTS

[0026] The present invention comprises a self-igniting system which includes a chamber or support, a source of a first gas and an oxygen containing gas (oxidizer) to the chamber or the support, and a composition of matter disposed in the chamber or supported on the support that reacts with the first gas/oxidizer to preferably cause auto ignition of the first gas and oxidizer mixture to produce a flame or at least increases the temperature of the composition of matter to a point which could result in ignition of a combustible mixture e.g. a hydrocarbon such as methane, the system being positioned in tubing or other such earth bore hole tubulars, e.g., tubing, casing, etc. to ignite a combustible fuel mixture in the tubular as, for example, igniting a suitable burner disposed in the tubular, the burner being supplied with a combustible fuel mixture. Alternatively, the self-igniting system can be used to ignite a combustible mixture issuing from an opening in a flare stack, the self-igniting system being supported sufficiently close to, or in the opening in the flare stack to effect ignition of the issuing combustible mixture.

[0027] The oxidizer is an oxidizing gas of the type that will support combustion. Typically, the oxidizer will be an oxygen containing gas, e.g., air, O₂, etc. The interaction or reaction between the first gas (hydrogen-containing gas) and the composition of matter produces an exothermic reaction, which can raise the temperature of the composition of matter to above the auto ignition temperature of the first gas. At the present time, the invention contemplates that the first gas is hydrogen, the oxidizer is air and the composition of matter is a platinum group metal, e.g., palladium, in any form, which when contacted with the hydrogen/oxidizer mixture results in the catalyzed reaction of hydrogen and the oxygen in the air. Typically, when the hydrogen/air mixture contacts the catalytic material, the temperature of the platinum/palladium, etc., is elevated well above the auto ignition temperature of hydrogen, i.e., greater than about 1,080° F. The hydrogen/air mixture ignites and results in a flame that can be propagated to a burner ignition zone to ignite a combustible mixture issuing from a suitable burner assembly into the burner igniter zone.

[0028] It is well known that the combination of hydrogen and oxygen to form water is an exothermic process; however, hydrogen and oxygen will not react automatically when mixed together because of the large activation energy needed to initiate the reaction. It is also known that the mechanism of the reaction is extremely complex and that one of the initiation steps is breaking of the bond between the two hydrogen atoms of the hydrogen molecule which requires 432 kJ/mole. This energy is typically initially provided by a spark or flame. After the reaction begins, the energy produced from it will provide the necessary energy to continue breaking apart the hydrogen molecules. A cata-

lyst provides an alternative mechanism that has a lower activation energy that allows the reaction to proceed without the requirement of the initial addition of energy via a flame or spark. Hydrogen molecules will adsorb to the platinum or palladium surface. The energy of the interaction between the hydrogen atoms and the platinum or palladium surface contributes to the breaking of the bond between the hydrogen atoms in the hydrogen molecule. The separate hydrogen atoms are then free to react at the surface or leave the surface and participate in the water forming steps.

[0029] While the invention will be described with particular reference to the use of hydrogen and an oxidizer (air) impinging on platinum, it is to be understood that it is not so limited. Thus, the invention contemplates the use of other compositions of matter which will react with a gas in a fashion similar to that described above with respect to the reaction between hydrogen and platinum. Additionally, any other metal, alloy, or composition of matter which will react with hydrogen in the presence of an oxidizer (air) to bring about the catalyzed reaction of hydrogen and oxygen described above is also contemplated. Further, although currently unknown to the inventor, the invention also contemplates that other gases or mixtures thereof can be brought into contact with other compositions of matter, also presently unknown to the inventor, which will result in a catalyzed auto ignition of such other gases in the presence of a suitable oxidizer such as air, oxygen or the like. The particular form of the composition of matter, e.g., the platinum or palladium-containing material will vary depending upon the end-use, the specific design of the support or housing for the catalyst and other factors. Thus, the platinum can be disposed or carried on an inert refractory-type carrier such as alumina, silica, titanic, etc., which can be in the form of pellets, granules or formed bodies, e.g., a compacted mass of the platinum group metal/carrier mixture. The platinum group containing material can also take the form of a sponge. At the present time, applicant has found that platinum supported on a foam-like structure made of a material known as Fecralloy and marketed by CRI Catalyst Company can be used to form an excellent catalytic material for use in the present invention. The Fecralloy which is in the form of a hard foam pad or sponge normally contains 22 percent chromium, 5.3 percent aluminum, a small amount of yttrium in addition to iron. The Fecralloy material can withstand temperatures in excess of 2000° F. The Fecralloy material bearing the platinum metal deposited thereon can be formed into numerous shapes including tubular bodies. It is desirable that, whatever form the platinum group composition takes, it have some porosity so as to provide the necessary surface area for the hydrogen/oxidizer gas mixture to contact.

[0030] Referring now to FIG. 1, there is shown one embodiment of the igniter assembly used in the apparatus of the present invention. The igniter assembly, shown generally as 10, comprises a tubular housing 12 which is attached at one end to an air intake, manifold 14 and at the opposite end to a flame propagation tube 16. Received in manifold 14 is a conduit 18 through which a hydrogen-containing gas flows from a source not shown. Manifold 14 is provided with a series of openings 20 which can be in generally surrounding relationship to conduit 18. As seen, the end 22 of conduit 18 faces the throat portion of a Venturi-type tube 24 attached to tubular housing 12. Venturi tube 24 also forms a retainer for a hollow cylindrical section 26 of a suitable catalytic mate-

rial as described above. Tube 16 also serves as a retainer to hold section 26 in position in tubular housing 12. In operation, a hydrogen-containing gas passing through conduit 18 under pressure passes into the throat of Venturi tube 24 and then into the hollow core 27 of catalyst section 26. The flow of the hydrogen-containing gas through conduit 18 toward the throat of tube 24 results in an aspirating effect whereby air from an ambient source is drawn in through holes 20 of manifold 14. The air and hydrogen-containing gas mix upon entering tube 24, the combined mixture of hydrogen-containing gas and air (or other oxygen containing gas) flowing through the hollow core 27 and into contact with catalyst section 26. The interaction of the hydrogen with the platinum in catalyst section 26 and in the presence of oxygen results in an exothermic reaction which causes auto ignition of the hydrogen. At auto ignition, there is a burst of flame resulting in a flame front which propagates in both directions in housing 12, i.e., both toward manifold 14 and out tube 16. This flame front propagates out tube 16 at a high velocity and can ignite a combustible mixture that it contacts such as a combustible mixture from a burner or other suitable piece of equipment, e.g., a flare stack, it being understood that the combustible mixture include an oxygen-containing gas from a suitable source. Generally speaking, the burning velocity of hydrogen in air is between about 2.7 to about 3.5 m/sec. Additionally, the flame temperature is extremely hot, the flame temperature for a 19.6 percent by volume hydrogen and air mixture being 2321° K. In effect, this high velocity, high temperature flame front issuing from tube 16 behaves essentially like a spark from an electrical discharge. Following this initial burst of flame, the hydrogen will continue to burn at the end 22 of conduit 18 but the hollow core 27 will be substantially free of flame. In this regard, the end 22 of conduit 18 is positioned a distance away from catalyst section 26 so as to ensure that following the initial burst of flame which propagates in both directions in housing 12, the issuing hydrogen from conduit 18 will only burn at the tip 22 of conduit 18. This protects the catalyst section 26 from undue overheating which would result from a direct flame on catalyst section 26 if flame remained in the hollow core 27.

[0031] Referring now to FIG. 2, a modified tubular housing 26A is secured to a tubular extension 30 in which is disposed a conduit 32 through which a hydrogen-containing gas from a source (not shown) flows. Tubular extension 32 extends through a manifold block 34 which has an annulus 36 in surrounding relationship to tubular extension 32 and which is in open communication with an L-shaped port 38 which in turn is in open communication with a conduit 40 through which an oxygen-containing gas, e.g., air, or other types of oxidizer flows under pressure from a source, e.g., a compressor (not shown). In the embodiment shown in FIG. 2, the hydrogen issuing from the end 42 of tubular extension 32 mixes with the air passing through conduit 40, port 38, annulus 36 and annulus 31 and passes into the throat of tube 24 resulting in an exothermic reaction and a burst of flame as described above with respect to the embodiment of FIG. 1. Once again, it is desirable to position the end 42 of conduit 32 sufficiently far away from the end of catalyst section 26a to ensure that once the initial burst of flame in the hollow core 27 has subsided, a small pilot flame of hydrogen will remain on the end 42 of conduit 32 if hydrogen flow is continued.

[0032] Turning now to FIG. 3, there is shown yet another embodiment of the igniter assembly for use in the apparatus of the present invention. A tubular housing shown generally as 50 has an upset portion 52 which forms an annular recess 54 in which is disposed a tubular catalyst section 56 as described above with respect to catalyst section 26. Tubular housing 50 also has an extended flame front propagation tube 58.

[0033] Secured to tubular housing 50 is an annular flange 60 forming an annular air intake 62 in surrounding relationship to an extension 64 of tubular housing 50, extension 64 being secured to upset portion 52. Extension 64 is also provided with a series of openings or apertures 66 which communicate with air intake 62. Generally concentrically mounted in extension 64 is a hydrogen feed tube 68 having a tapered tip 70 forming a nozzle. The end of extension 64 threadedly receives a gland 72 which in turn threadedly receives a fitting 74. Fitting 74 is threadedly engaged by a nut 76, a ferrule 78 being disposed between nut 76 and fitting 74. It will be understood, in the well known manner, that when nut 76 is tightened onto fitting 74, ferrule 78 will form a fluid-tight seal around hydrogen feed tube 68. In operation, hydrogen from a source not shown flows under pressure through feed tube 68 and aspirates air through openings 66, the mixture of the hydrogen-containing gas and the air flowing into the portion of housing 52 forming recess 54 where it contacts catalyst section 56. As in the cases described above, catalyst section 56 is of a generally hollow cylindrical configuration and is conveniently made of a material as described above with respect to the embodiments discussed above. In any event, upon contact with the catalyst section 56 there is an exothermic reaction which results in auto ignition of the hydrogen with a sudden burst of flame which propagates a flame front through flame propagation extension 58 as well as in the opposite direction towards the tip 70 of hydrogen feed tube 68. As described above, this flame front propagation through tube 58 is much like a spark which is sufficient to ignite a combustible fuel in a burner or the like to which the end 59 of extension 58 is operatively connected.

[0034] Referring now to FIG. 4, there is shown a slightly different modification of the embodiment shown in FIG. 3 wherein the air or oxygen supply is from a forced air source through a tube 80 into an annular plenum 82 formed by an annular housing 84 which is attached to extension 64 of housing 58. The operation of the embodiment shown in FIG. 4 is substantially the same as that described above with respect to FIG. 3. It is to be noted that the use of forced air from a bottle source or other clean air source provides an advantage in that contamination of the catalyst is minimized. In this regard, air from some ambient sources can contain soot and other particulates which, over time, can effect the efficiency of the catalyst.

[0035] Turning now to FIG. 5, there is shown one embodiment of the present invention wherein the igniter assembly is used to ignite combustible materials issuing from a flare stack such as would be found in a refinery, chemical plant or other industrial application wherein off-gases, flue gases or the like, are flared so as to not be released directly into the atmosphere. Referring then to FIG. 5, a flare stack 90 has an opening 92 through which waste gases containing combustible gases would ordinarily escape to atmosphere if not burnt. Attached to flare stack 90 via brackets 94 is an igniter

assembly, shown generally as 96, which is substantially the igniter assembly shown in FIG. 3, and includes a flame propagation tube 100 terminating in a nozzle or burner tip 102. Hydrogen is supplied, under pressure, via hydrogen feed line 104 from a flow meter 106 connected to a line 108 which in turn is connected to a hydrogen source (not shown). In the system shown in FIG. 5, it will be understood that a flame is intermittently supplied to burner 102 as needed. In this regard, the system of FIG. 5 can be automated by the use of solenoid control systems or other logic control systems to provide hydrogen to the igniter assembly when ignition is required.

[0036] Turning now to FIG. 6, there is shown another embodiment of the present invention involving a flare stack. As in the case of the embodiment shown in FIG. 5, the ignition assembly shown generally as 96 is attached to a flame propagation tube 112. It will be noted that with respect to the embodiments shown in FIGS. 5 and 6, air to be mixed with the hydrogen is by means of aspiration of ambient air as shown in FIG. 3 rather than by forced air being introduced as shown in FIG. 4. However, as seen hereafter, it will be understood that a system such as shown in FIG. 4 could be employed in either of the embodiments of FIGS. 5 or 6. Flame propagation tube 112 is attached to a pilot burner 114. Pilot burner 114 is in turn attached to a tube 115 to which is connected to an air aspirator 116 into which the end of a flow line 118 terminates. Methane, propane, or some light hydrocarbon gas from a source not shown flows through flow line 118 into aspirator 116 where it mixes with air and then flows through tube 115 to pilot burner 114. In the embodiment shown in FIG. 6, the methane or other light hydrocarbon gas flowing through line 118 and into pilot burner 114 would be ignited by means of igniter assembly 96 and would normally stay lit such that any combustible materials issuing from opening 92 and flare stack 90 would be ignited. However, it will be understood that pilot burner 114 could be selectively lit when desired.

[0037] FIG. 7 shows yet another embodiment of the invention for use with a flare stack. The embodiment shown in FIG. 7 differs from that shown in FIG. 6 in that the igniter assembly, shown generally as 120 is substantially the same as described with respect to the embodiment shown in FIG. 4, i.e., instead of being an air aspiration system, the embodiment shown in FIG. 7, like the embodiment shown in FIG. 4, uses a forced air system wherein air via a line 124 is supplied through a flowline 126 from a line 128 from a source such as an air compressor or the like, not shown. Additionally, hydrogen supplied to igniter assembly 120 is connected to a solenoid valve 130 forming part of an automatic flare pilot ignition system which typically incorporate thermocouples, optical flame monitors or the like which detect the absence of any flame, i.e., no pilot flame. In such event solenoid valve 130 would open such that hydrogen would be supplied to igniter assembly 120 ultimately resulting, as described above, in the ignition of a pilot flame from pilot burner 114 via methane or the like being supplied via line 118.

[0038] FIGS. 8 and 9 show a simplified hand-held wand employing an igniter assembly of the present invention. The igniter assembly shown in FIG. 8 is of a self-aspirating type substantially like that shown in FIG. 1. In this regard, a wand 140 has disposed therein, a catalyst section carrier 142, catalyst section 144, being in the form of a hollow cylinder

with a central opening 146. A retainer 148 together with Venturi tube 150 hold catalyst section 144 in place. A hydrogen feed line 152 running through wand 140 supplies hydrogen which aspirates air through holes 154 in wand 140, holes 154 being located just upstream of tube 150. A hydrogen supply line 154 connected to a source of hydrogen such as a tank 156 is connected by a coupling 158 to wand 140.

[0039] Turning now to FIG. 10, there is shown a typical subterranean usage of the apparatus of the present invention. An earth formation 200 has drilled therein a borehole 204, borehole 204, as seen, having a vertical section 206 which extends to the surface and a generally horizontal section 208 running generally parallel to the surface. Disposed in the borehole 204 is casing 210, casing 210 being cemented via cement 212 in the vertical section 206. As shown, the horizontal section 208 of borehole 204 forms an annulus around casing 210 but it will be recognized that it could be filled with substances which aid heat conductivity or transfer, if desired. In any event, casing 210 extends into a formation 214 containing hydrocarbonaceous materials such as coal, oil, heavy oils, tar sands, shale oil or the like. Disposed generally concentrically in casing 210 is tubing 216 which like casing 210 has a vertical section and a generally horizontal section. Disposed in tubing 216 are a series of igniter assembly/burner modules shown generally as 218 and described more fully hereafter. As can be seen, modules 218 are staggered along the length of tubing 216. The burners B of modules 218 are ignited by means of the ignition assemblies C, air being forced down tubing 216 from a compressor or other source of forced air. The air moving down tubing 216 is heated by combustion gases and the flames issuing from the burner of modules 218. The mixture of hot air and combustion gases exits the end 220 of tubing 216 and passes upward in the annulus 222 between tubing 216 and casing 210. The heated air combustion gases moving through the annulus 222 heats casing 210 and ultimately the air or other material in borehole 204 surrounding casing 210 eventually heating the hydrocarbonaceous-containing formation 214. Depending upon the temperature which is generated, hydrocarbons in the formation 214 are vaporized and/or pyrolyzed to smaller more valuable and more easily recoverable molecules which can then be recovered by a production well shown generally as 230 which extends down into formation 214.

[0040] It will be apparent that a number of casing/tubing combinations such as shown in FIG. 10 can be run side-by-side, stacked or virtually in as any other array in formation 214 to achieve desired the degree of heating and/or pyrolysis. Further, any number of production wells can be positioned in formation 214 to recover the vaporized/cracked hydrocarbons from the formation.

[0041] Referring now to FIG. 11 there is shown in greater detail the igniter assembly/burner modules 218. Modules 218 comprise a burner B have a housing forming a chamber 246A, chamber 246A being also defined by a front wall 242 in which are positioned a series of holes 244 (see FIG. 12) and a back wall 243. Chamber 246A essentially forms an annular plenum inside housing 240. Extending through housing 240 is a main methane supply line 246 which as seen in FIG. 10 extends through wall 242 and passes through each of the igniter assembly/burner modules 218. A slip stream of methane is removed from supply line 246 via a

conduit 248 and introduced via a fitting assemblage 250 into an aspirator housing 280. Aspirator housing 280, as seen, is a tubular member having a series of holes 282 and is attached to wall 243. Conduit 248 extends into aspirator housing 280 and terminates in a tapered tip or nozzle 284. As methane flows through aspirator housing 280, air is drawn in from the interior of tubing 216 through holes 282 where it mixes with the methane issuing from nozzle 284, the mixture being forced under the pressure of the methane into an opening 286 in the back wall 243 of housing 240. In effect, in the embodiment shown in FIG. 11, the same air that is ultimately used to heat the formation, i.e., the air being pumped into tubing 216, forms the oxidizing gas and is aspirated through holes 282 in aspirator/nozzle assembly 280. Also extending through plenum 246A is an igniter assembly C of the forced air type substantially as shown in FIG. 2. In this regard, a manifold 252 is connected to a main air supply line 254 by means of a conduit 256. Air supply line 254, as seen in FIG. 10, runs from the surface along the full length of the tubing to feed successive igniter assembly/burner modules 218. Manifold 252 is also connected via a conduit 258 to a hydrogen supply line 260 which as in the case of the methane line 246 and air line 254 extends to the surface and feeds all of the igniter assembly/burner modules 218 staggered along the length of tubing 216. In the manner described above, air and hydrogen are admixed and contact the catalyst segment such as shown in FIG. 3 to emit a burst of flame at the front surface of wall 242 whereby the methane/air mixture issuing from ports 244 is ignited.

[0042] It will be understood with respect to the embodiment shown in FIGS. 10, 11 and 12, that once the burners B are lit, the flow of hydrogen and air to the igniter assembly C can be discontinued unless and until the burners extinguish and need to be re-ignited.

[0043] In the preferred embodiment, the apparatus of the present invention utilizes, as can be seen from the above, a tubular housing in which is disposed the catalytic material. Preferably the catalytic material is in the form of a tube disposed in the tubular housing as seen, for example, in FIG. 1. It will be understood, however, that the catalytic material need not be in the form of a tube as noted above. Thus, the catalyst material could be in the form of pellets, granules or the like, held in a perforate housing disposed in the tubular housing. In the preferred case when a pilot light is to be lit, the geometry of the igniter assembly is such that the tubular housing in which the catalytic material is positioned has a flame front propagation tube attached to the tubular housing at one end. The flame front propagation tube can vary in length from about 2 inches up to about 15 feet depending upon the particular application. At the other end of the tubular housing and when self air aspiration is used, a Venturi-type arrangement is preferably employed. In this regard and again as noted in FIG. 1, there is a Venturi tube at the mouth of which the hydrogen-containing gas and the oxidizing gas mix and then flow at a higher velocity through the tubular housing containing the catalytic material. The presence of the Venturi tube, as is well known to those skilled in the art, increases the velocity of flow of the hydrogen-containing gas and the oxidizer through the tubular housing and hence through the bore through the cylinder of catalytic material. When there is sufficient hydrogen and oxygen present in contact with the active ingredient of the catalytic material, auto ignition of the hydrogen occurs with a flame front which moves in both directions along the

tubular member, i.e., toward the end to which the flame propagation tube is attached and toward the end through which the Venturi tube is attached. The flame propagation, at high velocity, travels through the flame propagation tube and essentially acts as a spark at the source of a combustible fuel which can be issuing from a pilot burner, a burner, a flare stack or the like. However, unless excessive hydrogen is being introduced into the tubular housing containing the catalytic material, only a small flame of hydrogen will remain lit at the outlet of the hydrogen feed tube. While in the embodiments shown, and preferably, the tip of the hydrogen tube nozzle or the like through which the hydrogen under pressure is flowing is displaced somewhat axially from the start of the catalyst section. However, it is to be understood that the tip of the hydrogen tube, nozzle, etc., could be positioned so as to be in the hollow core in the catalyst section. It is clearly preferably that the hydrogen-containing gas be introduced into the tubular housing in the form of a stream as opposed to simply being diffused into the tubular housing. It is believed that by introducing a stream of the hydrogen-containing gas into the tubular housing containing the catalyst section, there results in a more uniform self-ignition of the hydrogen in the catalyst section thereby providing better flame propagation and enhancing the "spark-like" igniting capability of the igniter assembly used in the present invention.

[0044] The ignition system of the present invention provides a virtually foolproof method to ignite a combustible gas or other combustible mixture in a remote environment such as in a tubular member disposed in an earth borehole or in connection with a flare stack.

[0045] It is anticipated that the unique igniter assembly of the present invention can be designed for multiple burners, e.g., 15 to 40, which can be spaced along a length of tubing disposed in a borehole. It is also anticipated that the burner output from each burner will be 50,000 to 125,000 BTU/hr. The igniter assembly of the present invention will be capable of handling inlet combustion temperatures from ambient to 500° F. while withstanding downstream combustion air temperatures of up to 1,500° F. The igniter assembly of the present invention can be used in hot start-up conditions, as well as under conditions where water is present, i.e., wet conditions. As described above, the igniter assembly/burner module will fit inside a 3" I.D. burner tube. It is anticipated that the service life of the igniter assemblies will be 3-5 years with little to no maintenance.

[0046] The marked novelty of the igniter system of the present invention is best demonstrated by the fact that under the parameters set out above, e.g., having to dispose the burners in a 3" I.D. tube, in downhole conditions at elevated temperatures, in the presence of moisture and with a repetitive and long lifetime, it accomplishes what electric igniters or any other heretofore known ignition systems cannot accomplish. It overcomes the difficulty of having to protect ignition wires in a hard wired system using an electric igniter from prolonged exposure to a temperature of 1,500° F., a temperature that would almost certainly damage such electrical systems over time. It permits the use of multiple burner systems, e.g., 15 to 40 burner systems, each with an igniter assembly, and such a system would be virtually impossible using electrical igniters because the small I.D. of at least some of the burner tubes in which the igniter system will be placed would not permit the use of 15 to 40 ignition wires

that would be required in such a multiple burner system. Furthermore, in any electric spark ignition system it is almost certain that delicate ceramics or the like would be used and such materials are frangible, easily damaged and would require excessive maintenance. Additionally, in an extended length of burner tubing, e.g., 5,000 ft., the voltage drop to the igniters would be excessive requiring repeaters, again complicating the system and making it virtually impossible to fit it into a small diameter (3" I.D.).

[0047] As can be seen from the above, the igniter assembly used in the apparatus of the present invention generally falls into two categories. In one case, the combustion air required for auto ignition of the hydrogen-containing gas is supplied to the igniter assembly from the surrounding ambient air by introducing hydrogen into a Venturi at a sufficient velocity. In this case, the Venturi effect causes the required amount of oxidizer gas to be drawn into the Venturi tube where it is mixed with the hydrogen-containing gas and then introduced to the catalyst section.

[0048] The second basic type of igniter assembly is of the forced air type wherein the oxidizer required for auto ignition of the hydrogen-containing gas supplies to the igniter assembly by an air compressor or any other controlled air source, e.g., pressurized bottled air. In this regard, when forced air is employed, a flow meter, regulator, orifice plate or any other means of accurately controlling airflow can provide the desired specific amounts of combustion air into the igniter assembly. This type of igniter assembly is particularly suited for applications where purity of the ambient or surrounding outside air is in question.

[0049] Regardless of whether the igniter assembly is of the self aspirating or forced air type, as described above, in all cases the hydrogen is introduced into the tubular housing which holds the catalyst under a pressure to ensure flow of the hydrogen-containing gas/oxidizer through the tubular housing and into contact with the catalyst contained therein. Generally speaking, the hydrogen pressure will range from about 0.1 to about 3 psi with flow rates from about 50 to about 1400 cc/sec.

[0050] As can be seen from the above, the combination of the igniter assembly, the burner, and the tubular member in which it is disposed and which can be positioned downhole provides the basis for a method of vaporizing and/or pyrolyzing hydrocarbons and subterranean formations such that they can be recovered more easily from producing wells. It is also to be understood that the method can include simply heating the formation to make the oil less viscous whereby it can be pumped more efficiently, i.e., without the necessity for vaporizing and/or pyrolyzing any of the oil. The igniter assembly in combination with the flare stack provides an easy and efficient method of igniting combustible mixtures issuing from a flare stack and eliminates the need for spark igniters, continual pilot flames, etc.

[0051] Modifications of the apparatus, compositions, procedures and conditions disclosed herein that will still embody the concept of the improvements described should readily suggest themselves to those skilled in the art, and are intended to be encompassed within the spirit of the invention presently disclosed herein as well as the scope of the appended claims.

What is claimed is:

1. An apparatus for igniting a combustible medium in a tubular member in an earth borehole in a subterranean formation comprising:

an igniter assembly, said igniter assembly comprising:

a support;

a catalytic material carried by said support, said catalytic material comprising a substance which reacts with a hydrogen-containing gas in the presence of an oxidizing gas to produce an exothermic reaction and a temperature sufficient to cause auto ignition of said hydrogen-containing gas;

a source of said hydrogen-containing gas; and

a source of said oxidizing gas; and

a tubular member disposable in said borehole, said igniter assembly being positioned in said tubular member.

2. The apparatus of claim 1, wherein said igniter assembly comprises an elongate tubular housing having a first end and a second end, said catalytic material being disposed in said tubular housing, said hydrogen-containing gas and said oxidizing gas being introduced into said first end of said housing, said hydrogen-containing gas being introduced under pressure into said tubular housing.

3. The apparatus of claim 2, wherein said catalytic material is in the form of a tube disposed in said tubular housing.

4. The apparatus of claim 3, wherein said tube of catalytic material comprises a platinum group metal carried on a metallic foam structure.

5. The apparatus of claim 3, wherein said source of hydrogen-containing gas comprises a feed tube, said feed tube having an end opening axially displaced from said tube of catalytic material and there is a Venturi-type tube attached to said tubular housing and facing said end opening of said feed tube.

6. The apparatus of claim 1, wherein said source of air comprises ambient air.

7. The apparatus of claim 1, wherein said source of air comprises forced air.

8. The apparatus of claim 1, wherein there are a plurality of igniter assemblies positioned in said tubular member and staggered there along, each of said igniter assemblies being associated with a burner.

9. An apparatus for igniting a combustible medium issuing from an opening in a flare stack comprising:

an igniter assembly, said igniter assembly comprising:

a support;

a catalytic material carried by said support, said catalytic material comprising a substance which reacts with a hydrogen-containing gas in the presence of an oxidizing gas to produce an exothermic reaction and a temperature sufficient to cause auto ignition of hydrogen-containing gas;

a source of said hydrogen-containing gas; and

a source of said oxidizing gas; and

a mount for positioning said igniter assembly adjacent said opening in said flare stack.

10. The apparatus of claim 9, wherein said igniter assembly comprises an elongate tubular housing having a first end and a second end, said catalytic material being disposed in said tubular housing, said hydrogen-containing gas and said oxidizing gas being introduced into said first end of said housing, said hydrogen-containing gas being introduced under pressure into said tubular housing.

11. The apparatus of claim 10, wherein said catalytic material is in the form of a tube.

12. The apparatus of claim 11, wherein said tube of catalytic material comprises a platinum group metal carried on a metallic foam structure.

13. The apparatus of claim 11, wherein said source of hydrogen-containing gas comprises a feed tube, said feed tube having an end opening axially displaced from said tube of catalytic material and there is a Venturi-type tube attached to said tubular housing and facing said end opening of said feed tube.

14. The apparatus of claim 9, wherein said source of air comprises ambient air.

15. The apparatus of claim 9, wherein said source of air comprises forced air.

16. The apparatus of claim 9, wherein said mount comprises a bracket.

17. The apparatus of any of claims 1 or 16, wherein said igniter assembly comprises an elongate tubular housing, said catalytic material being disposed in said tubular housing, said hydrogen-containing gas being introduced under pressure into said tubular housing at a pressure of between 0.1 and 3 psi.

18. The apparatus of claim 17, wherein said catalytic material is in the form of a tube.

19. An igniter assembly comprising:

a tubular housing having a first end and a second end;

a catalytic material disposed in said tubular housing, said catalytic material comprising a substance which reacts with a hydrogen-containing gas in the presence of an oxidizing gas to produce an exothermic reaction and a temperature sufficient to cause auto ignition of the hydrogen in said hydrogen-containing gas;

a source of hydrogen-containing gas, said source of hydrogen-containing gas comprising a tubular section for introducing said hydrogen-containing gas into said first end of said tubular housing; and

a source of oxidizing gas for admixing with said hydrogen-containing gas.

20. The igniter assembly of claim 19, wherein said catalytic material is in the form of a tube disposed in said tubular housing.

* * * * *