



US 20070020097A1

(19) **United States**

(12) **Patent Application Publication**

**Ursua**

(10) **Pub. No.: US 2007/0020097 A1**

(43) **Pub. Date: Jan. 25, 2007**

(54) **TURBINE HOUSING AND FLOATATION ASSEMBLY**

(30) **Foreign Application Priority Data**

Oct. 13, 2003 (PH)..... 1-2003-000483

(76) Inventor: **Isidro U. Ursua**, Markina City (PH)

**Publication Classification**

(51) **Int. Cl.**  
*F01D 25/28* (2006.01)

(52) **U.S. Cl.** ..... 415/213.1

Correspondence Address:  
**ADAMS EVANS P.A.**  
**301 SOUTH TRYON STREET, SUITE 2180**  
**TWO WACHOVIA CENTER**  
**CHARLOTTE, NC 28282-1991 (US)**

(57) **ABSTRACT**

The invention relates to a turbine housing comprising a housing (2) body having a first end (8), second end (12) and a central region (4), wherein the housing body comprises a bore running therethrough, and wherein the bore tapers from a first larger cross-section at and/or in the region of the first and second ends to a second, smaller cross-section towards the central region. The turbine housing may also include a fluid flow restriction means arranged (34, 40) in use to restrict fluid speed, direction or location within the turbine housing.

(21) Appl. No.: **10/595,364**

(22) PCT Filed: **Oct. 13, 2004**

(86) PCT No.: **PCT/PH04/00010**

§ 371(c)(1),  
(2), (4) Date: **Apr. 12, 2006**

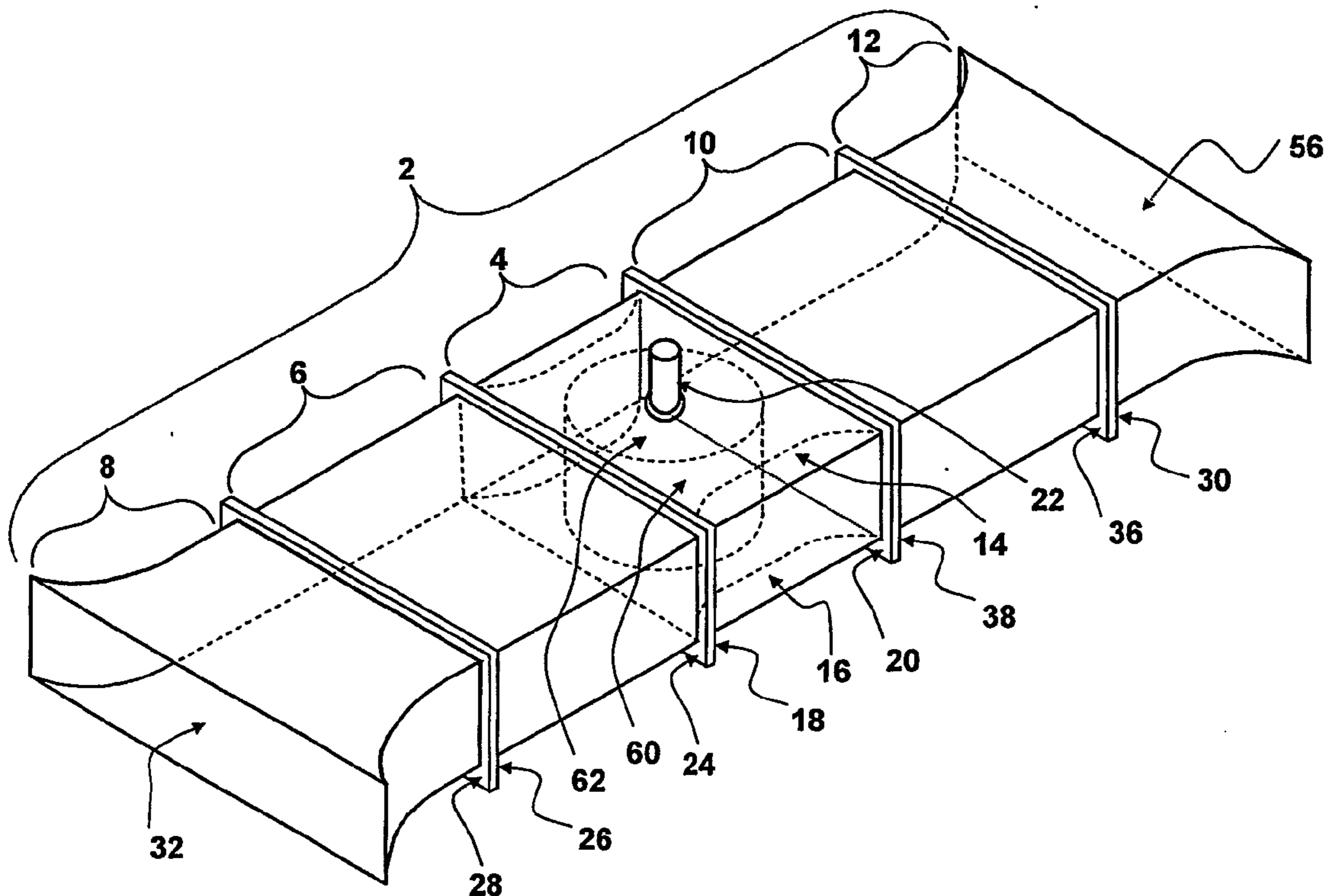

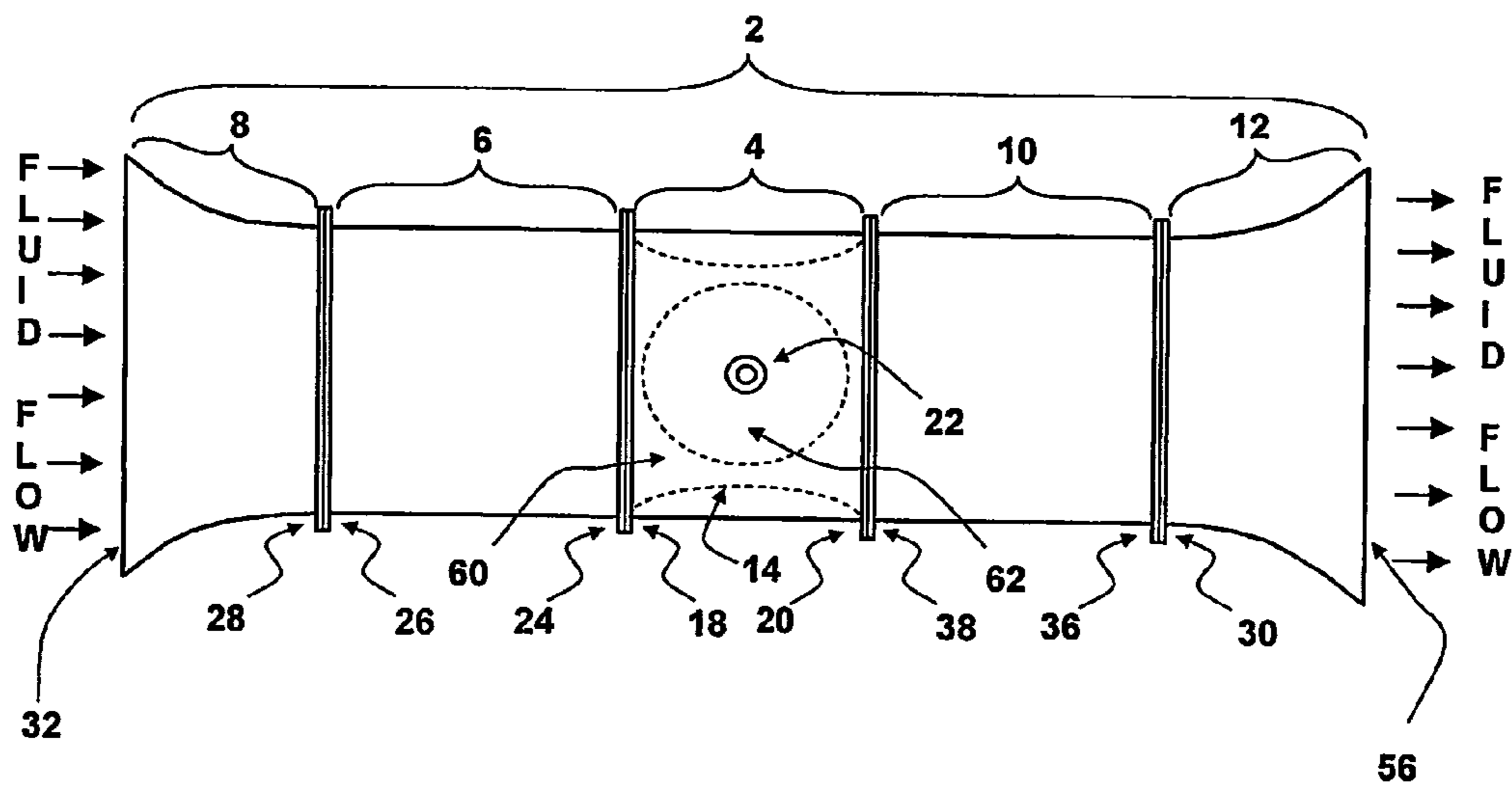

Figure 1

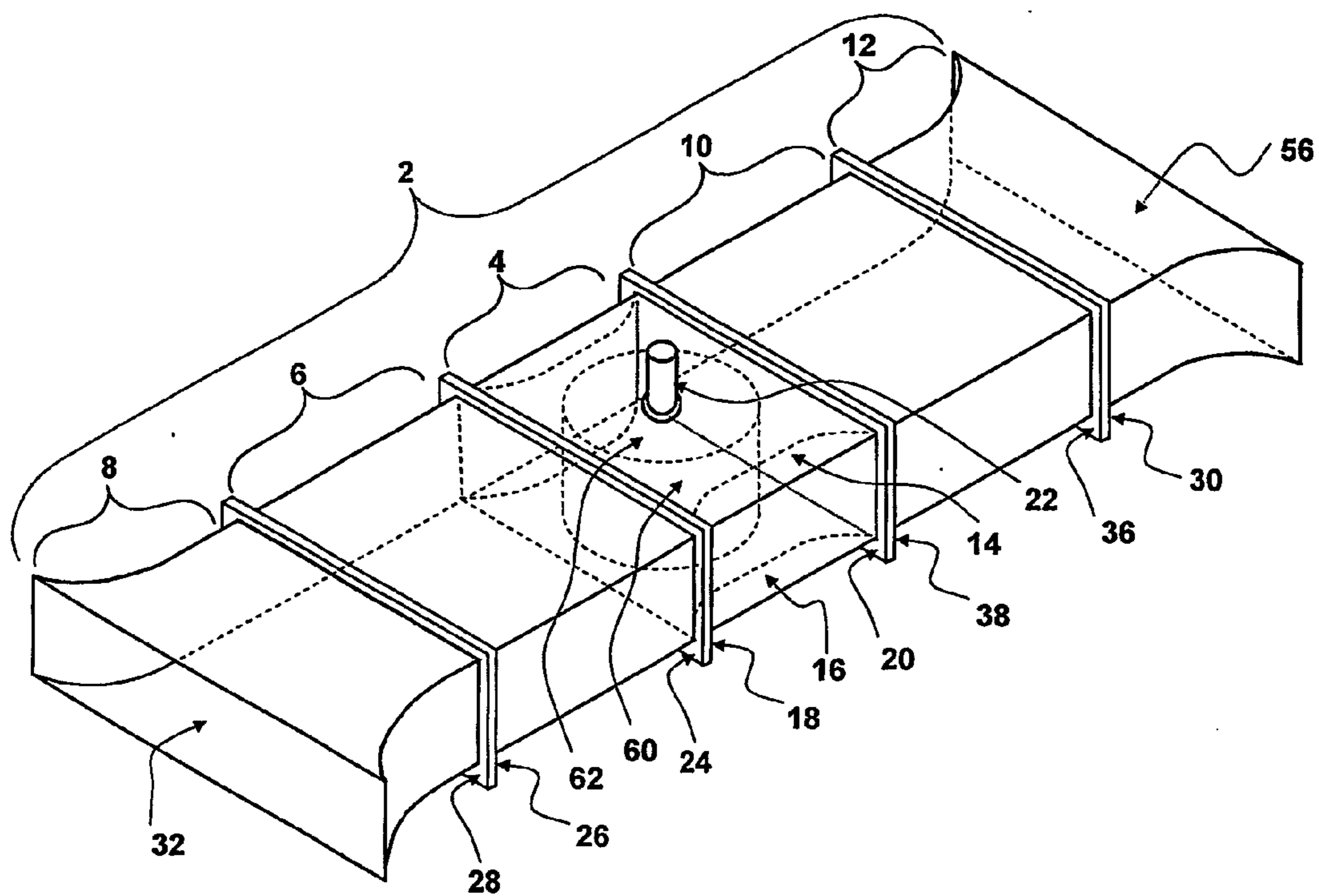

Figure 2

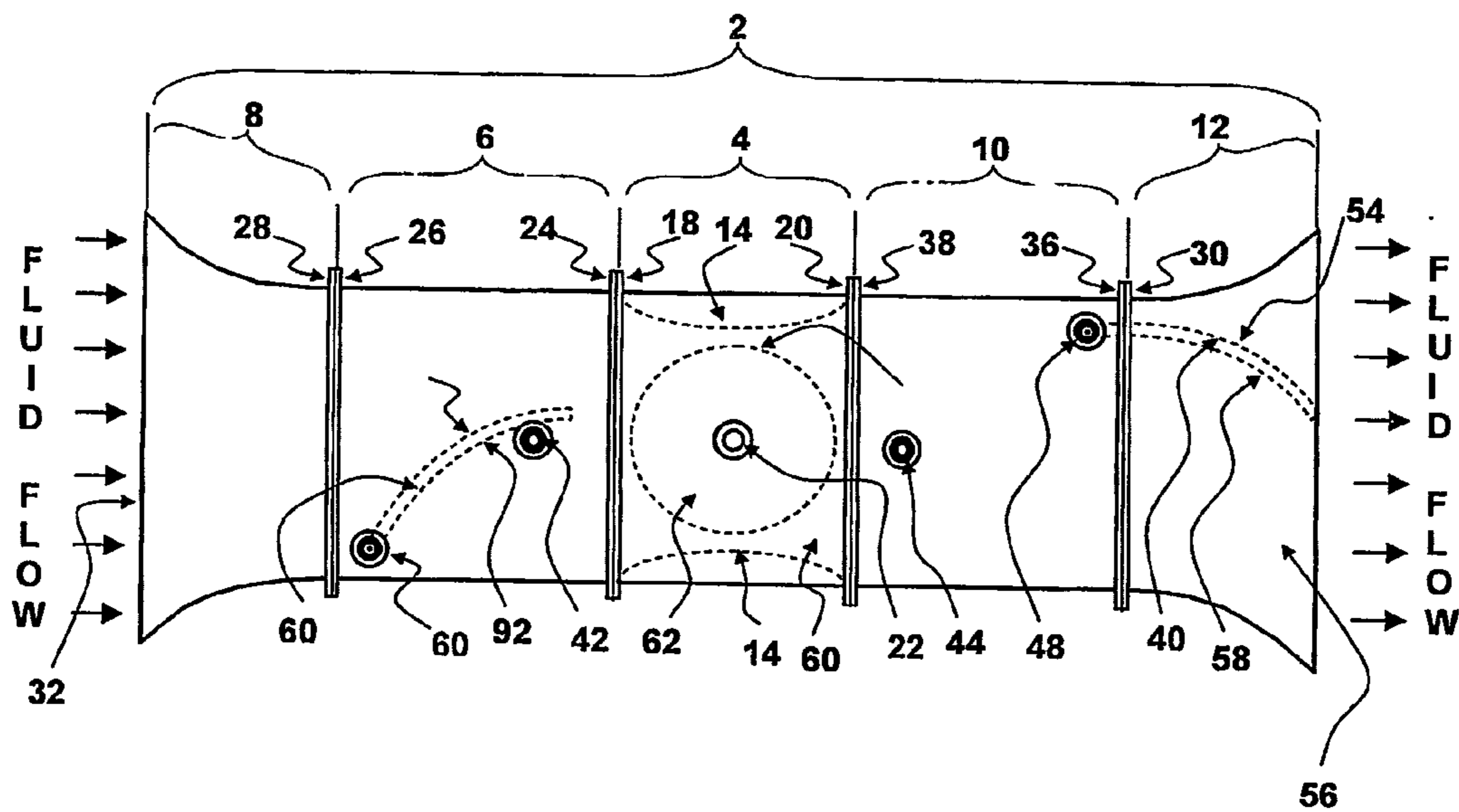

Figure 3

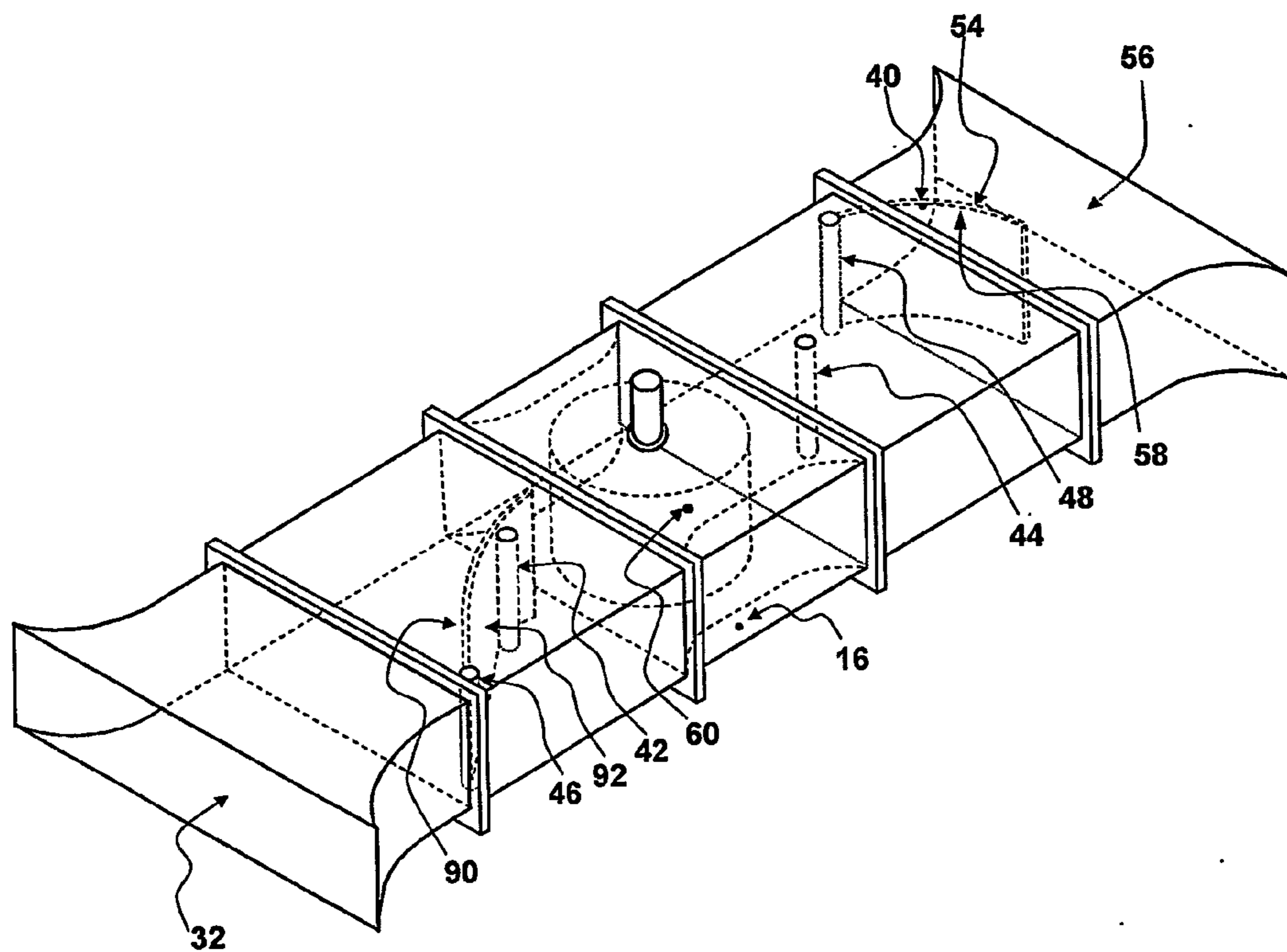
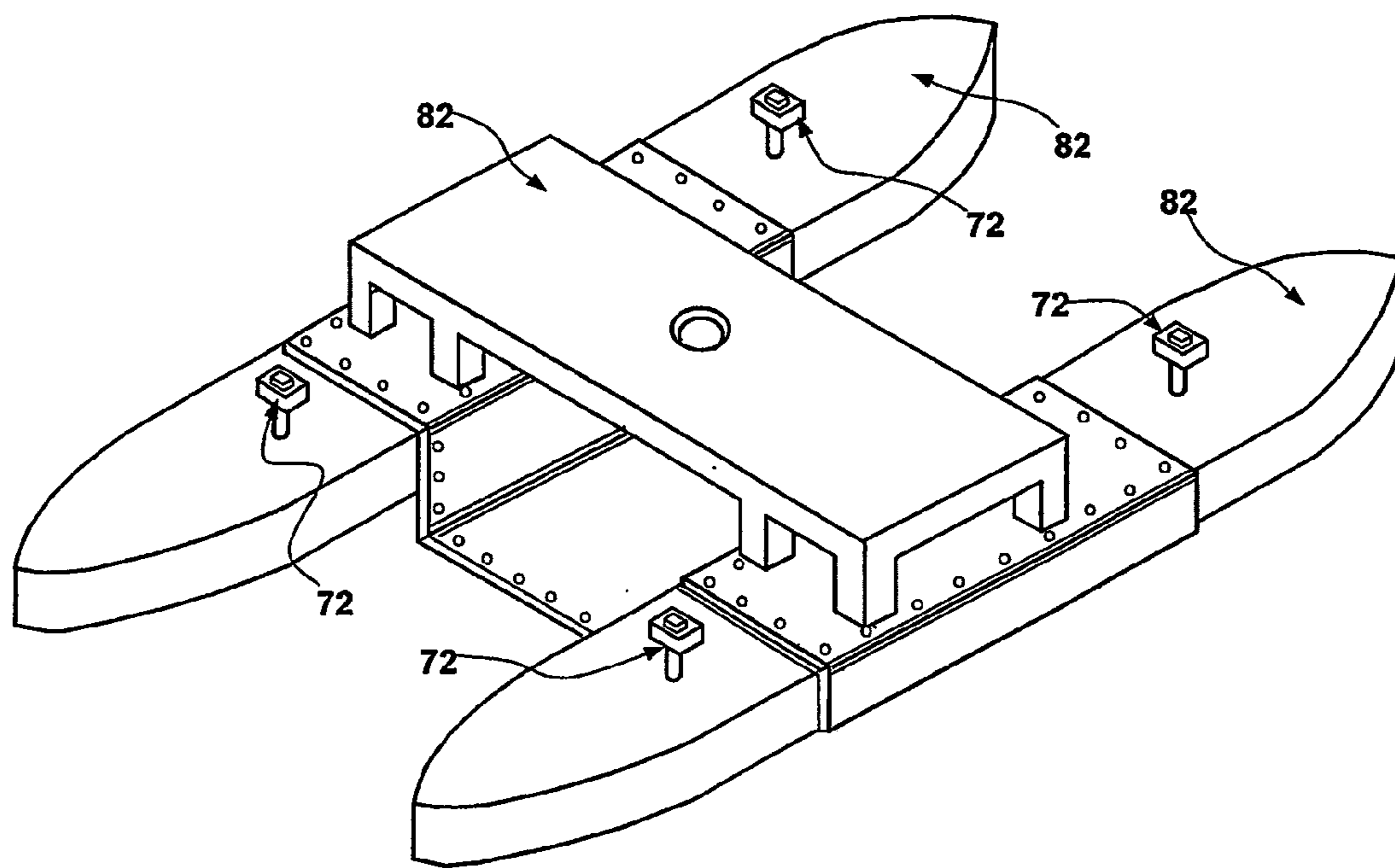

Figure 4



**Figure 5**



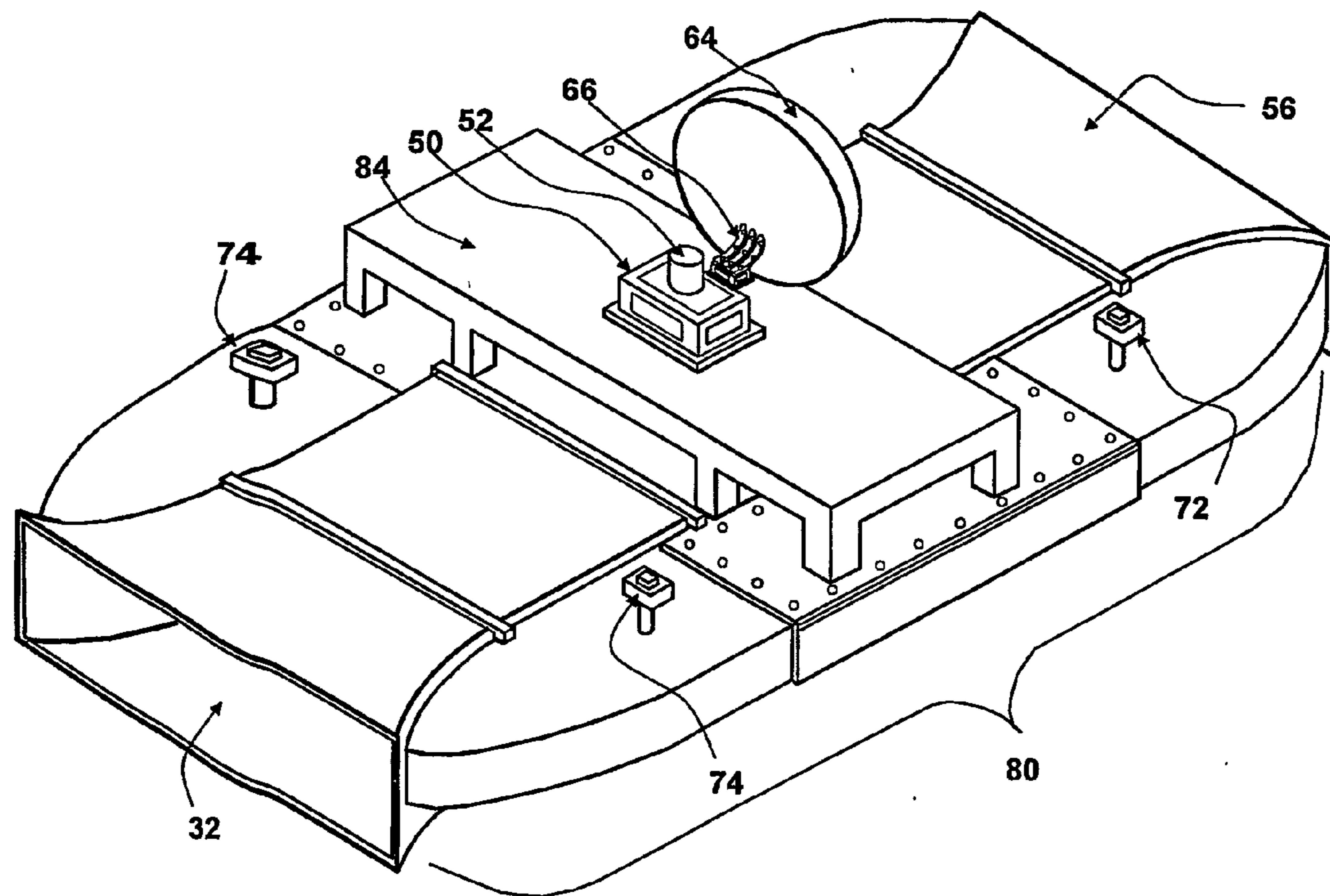

Figure 7



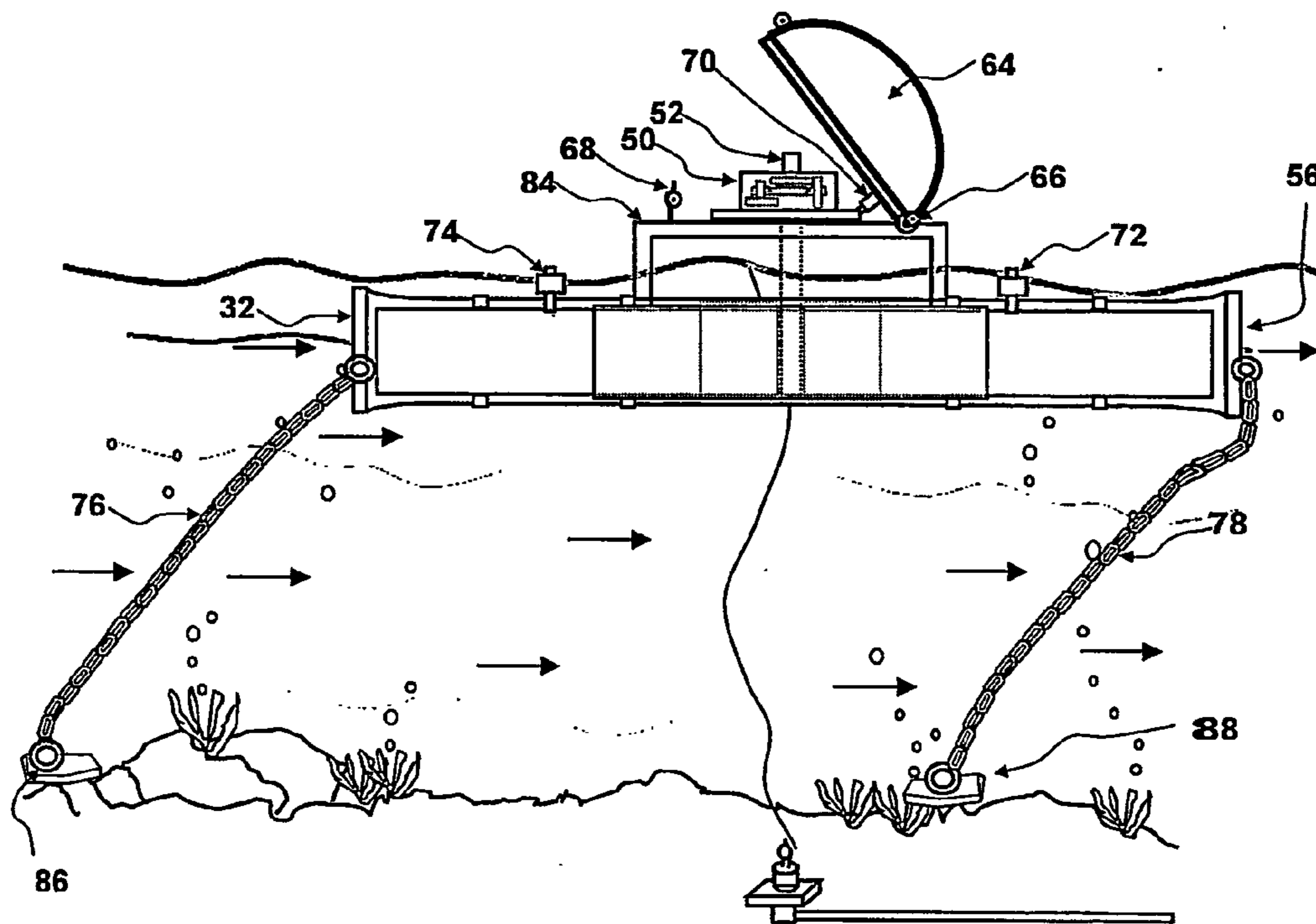

Figure 8

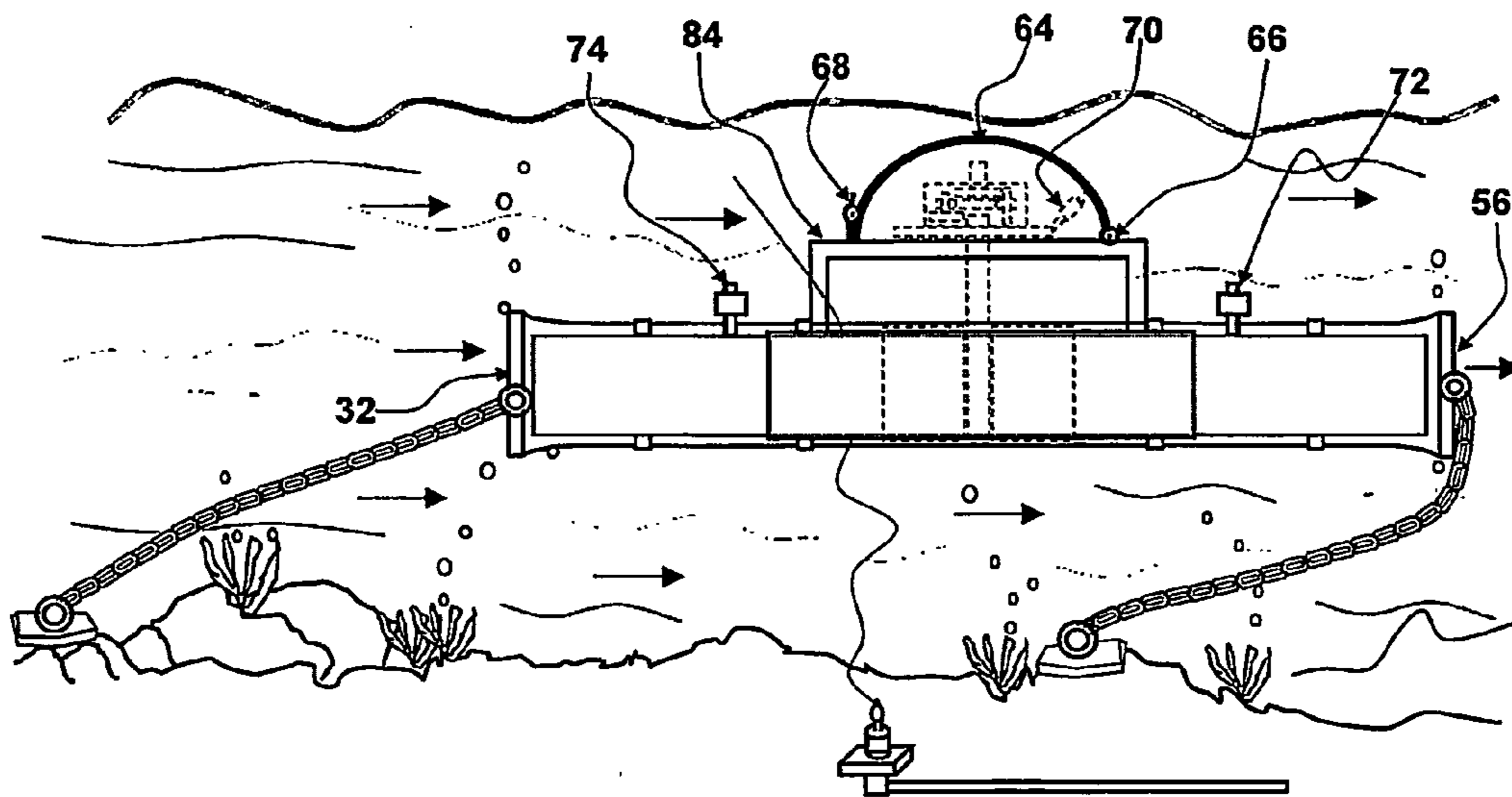
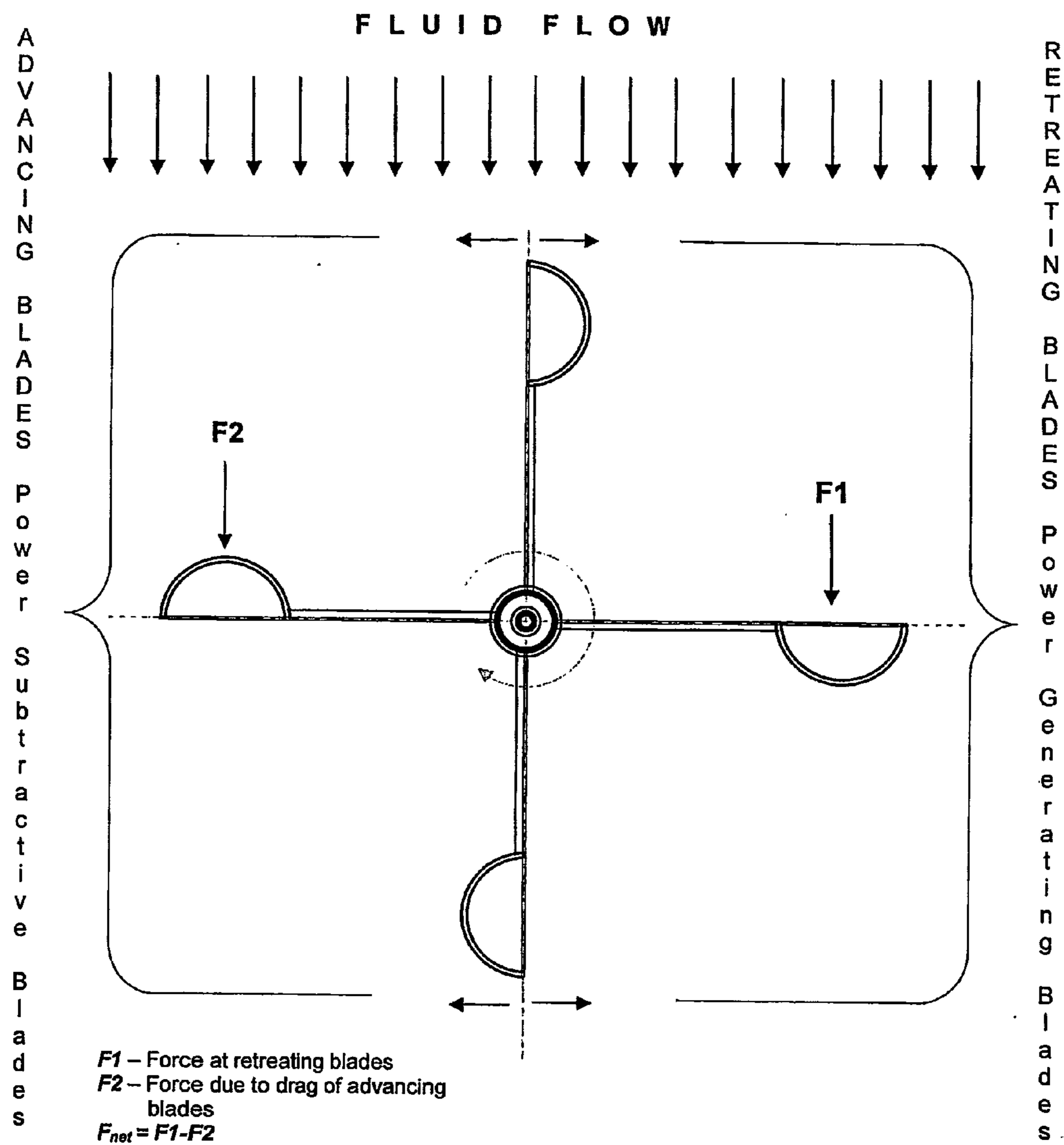

Figure 9



**Figure 10**

## TURBINE HOUSING AND FLOATATION ASSEMBLY

### TECHNICAL FIELD OF THE INVENTION

[0001] This invention relates to turbine housings and to power enhancement of prime movers, and in particular to prime movers which harness energy from free flowing fluid. The invention also extends to a method of increasing generated energy of prime movers.

### BACKGROUND TO THE INVENTION

[0002] Renewable and non-polluting sources of energy are currently in high demand. Traditional sources of generating power such as the combustion of fossil fuels, including coal, natural gas and oil, are becoming less and less favored due to their environmental disadvantages. The combustion of coal, oil or gas generates large quantities of carbon dioxide, oxides of sulfur and nitrogen, and other pollutant gases, which may contribute to global warming, acid rain, air pollution and a number of other environment and health damaging effects. World reserve of coal, oil and natural gas are also thought to be relatively low, and may run out in the foreseeable future.

[0003] Other sources of energy include nuclear fission, whereby atoms of radioactive elements are bombarded with a neutron source, which splits the radioactive element into an element or elements of smaller atomic mass, generating massive quantities of energy in the process. Unfortunately, the use of radioactive materials means that environmentally safe methods of disposal of waste are difficult to achieve. The radioactive waste generated is commonly stored in sealed containers and then buried in restricted access landfill sites or dumped at sea. There have been many occurrences of radioactive waste leaking from these containers and damaging the local environment. The damage caused by radioactive waste may be irreversible and the radiation generated by the waste may last decades. Thus, there is strong desire to produce or increase power production of non-polluting and renewable energy sources. Known non-polluting and renewable energy sources include tidal-powered electricity generators, and wind powered electricity generators. These types of generators generally employ turbines that are designed to translate the linear motion of wind or tidal water current into rotational motion of a turbine through a central hub, which is connected to a suitable energy generator.

[0004] For a particular or specific turbine subjected to a free flowing fluid for power extraction purposes, power generated by the turbine will entirely be dependent on the speed of the fluid when the mass is constant. The higher the site speed of the flow of fluid, the higher is the power generated by a specific or particular turbine subjected to that fluid flow.

[0005] Therefore, the maximum power produced by turbines used for wind, river, or tidal flow power extraction are dictated by the existing fluid speed; determined by the conditions set by the environment.

[0006] One of the aims of preferred embodiments of the present invention is to overcome or mitigate at least some of the disadvantages or limitations imposed by the existing environmental conditions, in particular the actual site speed

available from the fluid or medium from which power is extracted. The addition of a turbine casing or a turbine housing designed to increase fluid speed and which at the same time, directs the fluid to hit the turbine blades/buckets at the correct angle, maximizes power output that could not readily be available if the turbine were submerged, without the use of a casing. Amplifying the actual existing site fluid speed, power extracted by the turbine blades/buckets will have a dramatic increase of turbine power output as the speed or fluid velocity is squared in the kinetic energy equation.

[0007] In a vertical access turbine like an anemometer, viewed from the top, power is produced from one half the operating area. From the other half section, the blades/buckets advance through the incoming fluid producing counter-rotative forces that has to be subtracted from the power generated. Thus, eliminating the counter-rotative forces produces dramatic increase in power output.

[0008] A second aim of preferred embodiments of the present invention is to overcome or mitigate at least some of the disadvantages imposed by this counter-rotative forces that greatly influence turbine efficiency.

[0009] A third aim of preferred embodiments of the present invention is to overcome or mitigate at least some of the problems of fluid speed control encountered in harnessing power from free flowing fluids.

[0010] Machines operating in the open seas are subjected to extreme environmental weather conditions. High waves, winds, typhoons, as well as tidal waves are major considerations in the design of the machine that can withstand these forces. Thus, because of these considerations, widespread use of the open sea for power extraction becomes prohibitive.

[0011] A fourth aim of preferred embodiments of the present invention is to overcome or mitigate at least some of the disadvantages or limitations imposed by those extreme environmental conditions.

[0012] Another aim of preferred embodiments of the invention is to overcome or mitigate at least one problem of the prior art, whether expressly disclosed herein or not.

### SUMMARY OF THE INVENTION

[0013] According to a first aspect of the present invention, there is provided a turbine housing comprising a housing body having a first end, a second end and a central region, wherein the housing body comprises a bore running there-through, and wherein the bore tapers from a first, larger cross-section at and/or in the region of the first and second ends, to a second, smaller cross-section towards the central portion.

[0014] Preferably the cross-section of the bore in the central portion is rectangular, cylindrical, oval, square, or any other suitable cross-sectional shape. In preferred embodiments, the cross-section of the central portion of the bore is rectangular or circular.

[0015] Preferably the shape of the first and second end is frusto-conical or trumpet shaped. Alternatively, if the cross-sectional shape of the central portion is rectangular or square, preferably the shape of the first and second end comprises a flared extension of the rectangular cross-sectional shape.

[0016] Preferably the first and second end comprise a fluid inlet and fluid outlet respectively.

[0017] Suitably the central portion comprises means to mount a turbine, or a rotatable shaft of a turbine. Preferably the central portion comprises a bore of uniform cross-section, and suitably the means to house a turbine or rotatable shaft is located substantially centrally within the central portion.

[0018] Length-wise, along the centerline of the central portion of the housing, at the middle of the housing, for a vertical axis turbine, is where the shaft of a turbine is preferably to be installed or mounted. For a horizontal axis turbine, lengthwise, along the centerline of the housing, also in middle of the central portion housing, is where the turbine mountings are preferably to be located. Hereunto, it will be the casing of a vertical axis turbine that will be discussed, as design configurations are the same on both.

[0019] In actual manufacture, the turbine housing may be divided into five sections. Two identical inlet/outlet units are cut at the first and second ends. Next, are two identical conducting duct portions cut from both the resulting ends, the remaining middle portion becomes the turbine-housing portion. Together, the duct portions and turbine-housing portion comprise the central portion of the turbine housing. Both sides of the turbine housing portion are preferably double walled, with the inner walls, tapering sidewise towards both openings forming a venturi. Center of the housing of this turbine housing portion is where the vertical shaft of the turbine is preferably to be located and held by bearing assemblies.

[0020] Between the turbine housing portion and the inlet and outlet portions, is where the conducting duct portions are installed. The conducting duct portion is preferably a rectangular tubular section, open at both ends each with flanges for bolted connections to the flange end of one of the inlet or outlet portions at one end, with other end bolted to the flange of the turbine housing portion. This type of connection also applies to the other side of the turbine housing portion similar in arrangement outward to form a symmetrical assembly.

[0021] The bore of the second, smaller cross-sectional portion of the inlet and outlet portions preferably has a flange that joins the flange of conducting duct portion at one end. The other large cross-sectional size end is preferably a flaring opening that serves as the fluid intake/exhaust depending upon which way the fluid is coming from. In use, when free flowing fluid is allowed to enter at one end, it progresses inside and come out from the other end. The process is reversed when the exit side becomes the entrance.

[0022] When the housing is submerged in a free flowing fluid such that one end is facing the fluid flow, the fluid enters the inlet portion. The slowly decreasing volume of fluid flowing from the first, larger cross-sectional part of the bore to the second, smaller cross-sectional part of the bore causes the fluid to increase in speed. As the fluid passes the conducting duct portion, the fluid speed is stabilized. The conducting duct portion delivers the fluid to the entrance of the turbine housing portion where the fluid speed is further increased. At the throat of the venturi (in the turbine housing portion) where the fluid speed is maximum, power is extracted.

[0023] As the fluid comes out of the venturi's throat, the increasing cross-sectional size from the central portion of the bore to the larger cross-sectional size of the bore at the second end causes the fluid to reduce in speed. The fluid is then delivered to the conducting duct portion of the other side to stabilize the fluid speed. As the fluid enter and progresses inside the adjoining outlet portion, the slowly increasing area of the outlet portion further reduces the speed to a slightly lower speed than the outside main stream fluid speed, this allows the main stream to suck the fluid coming out of the whole housing.

[0024] In preferred embodiments, the housing comprises means to restrict fluid flow through the housing body, hereinafter referred to as "fluid flow restriction means".

[0025] Preferably the fluid flow restriction means comprises means to restrict fluid flow through pre-defined areas of the housing body. Alternatively and/or additionally, the fluid flow restriction means may restrict speed and/or direction of fluid flow through the housing.

[0026] In preferred embodiments, the fluid flow restriction means comprises a moveable member, moveable between a first position in which fluid flow is restricted axially along the housing body to, for example, one side of the housing body, and a second position in which fluid flow is not substantially restricted along the housing body.

[0027] Suitably, the fluid flow restriction means comprises a pivotable member, pivotable between the first and second positions. Preferably, the pivotable member is moveable between the first and second positions by action of fluid flowing through the bore.

[0028] In preferred embodiments, the fluid flow restriction means comprises two moveable members, one each located towards the first and second ends of the housing, and arranged in use such that one of the first and/or second fluid flow restriction means moves to the first position when the other of the second and/or first fluid flow restriction means moves to the second position.

[0029] Thus, in preferred embodiments, fluid entering the first end may impinge on the first fluid flow restriction means, and be restricted to flowing along a restricted portion of the central portion of the bore of the housing body in order to increase the velocity of fluid arriving at a turbine housed in the central portion. Conversely, fluid flowing out of the housing body may impinge the second fluid flow restriction means, moving it from the first or second position, such that fluid flow is not substantially restricted in velocity and direction out of the second end.

[0030] There may be a movement limiting means operably co-operable with the fluid flow restriction means, such that the fluid flow restriction means is limited between the first and second positions only. The movement limiting means may for example, comprise an arresting pin or other such member, which serves to prevent the fluid flow restriction means from moving out of the range of the first and second positions.

[0031] In preferred embodiments, adjacent to the wall, close to the forward flange of the conducting duct portion of the turbine housing, right side of the inflow during intake operation, a fluid flow restriction means in the form of a pivot pin is mounted in the conducting portion. The pivot pin

serves as support and pivot for a straight or a curvilinear rectangular plate. This pin allows the fluid flow restriction means to swing in during inflow, or to swing out during outflow. Rollers (not shown) are provided along the bottom part of the fluid flow restriction means for ease of operation.

[0032] In the conducting duct portion, lengthwise, close to the conducting duct portion inner flange, an arresting pin is attached to the turbine housing. The arresting pin arrests the inward swing of the fluid flow restriction means during the inflow to limit the inward travel and hold it in place approximately at the center during the whole intake operation. The arresting pin acts as a stopper, and its location position the fluid flow restriction means to directs the whole fluid mass or inflow toward correct angle of attack of the fluid in relation to the blades/buckets of the turbine to maximize power extraction. The other purpose of the fluid flow restriction means is to preferably block one half of the turbine section to provide a lower fluid speed area where the advancing blade/bucket portion of turbine goes against the incoming fluid flow.

[0033] Diverting one half of the mass of the inflow, causes one half of the fluid pathway to be blocked. This blockade create a reduce fluid speed downstream, along the blocked pathway, hence produces low resistance against the advancing or power subtractive blades/buckets, thereby increasing net power production due to lesser subtractive forces.

[0034] With the fluid flow restriction means installed in the conducting duct portions, during intake, the fluid flow restriction means produces a choking effect to the already accelerated fluid flow coming out from the intake/exhaust portion that feeds the intake side of the conducting duct portion. The fluid speed is further increased inside the conducting duct portion by the aid of the choking effect of the fluid flow restriction means. The turbine housing portion which houses a venturi maximize the speed. At the point of maximum fluid speed inside the venturi, power is extracted before it is allowed to expand through the increasingly widening area of the venturi at the opposite end of the turbine housing portion. The added speed introduced to the flow of the fluid produces additional power that could be extracted by the turbine, compared to the power it could produced without the use of the turbine housing.

[0035] As the fluid enters the adjoining conducting duct portion down stream of the turbine housing portion, the fluid hits the inboard face of the fluid flow restriction means which is at closed position resting on the arresting pin. The pressure exerted on the inboard face, pushes the fluid flow restriction means to slide open, allowing more room in this conducting duct portion to lower and stabilize the fluid flow. The fluid flow is then guided smoothly by the fluid flow restriction means through the intake/exhaust portion outlet. Ultimately, the fluid joins the mainstream running outside the whole assembly.

[0036] Thus, the speed of the fluid outside the turbine speed accelerator assembly is preferably multiplied several times before power is extracted. Directing and concentrating the mass of high speed fluid where it is most needed increases available power. At the same time, reducing the fluid speed encountered by the advancing blades/buckets, minimizes the subtractive forces thereby appraiseably increasing turbine efficiency.

[0037] During operation, when the fluid flow changes its direction, fluid enters from the former exhaust end. The fluid

flow restriction means at this time, at this end is at open position. Instead of the fluid flow pushing the fluid flow restriction means against the inward face, it now pushes at the opposite side or outward face of he fluid flow restriction means by the incoming fluid flow coming from this end. This allows the fluid flow restriction means to swing inward and pivot towards the close position to be stopped and rest against the arresting pin. The fluid flow restriction means remains closed all the time during in-take operation to create a choking and blocking effect to increase fluid speed at one section, and a low speed fluid flow at the blocked section. The fluid, now inside the conducting duct portion, is guided by the fluid flow restriction means to the turbine housing portion for power extraction. The process cotinually reverses every time the fluid direction reverses.

[0038] When the ocean is used as the medium, the turbine housing may be mounted or supported by permanent pylons (not shown) that are permanently embedded into the ocean floor, or suspended without permanently situated infrastructures by the use of at least one floatation unit that work under the inverted cup principle. The trapped air in the floatation unit preferably holds the turbine housing and floatation assembly afloat. At least one air release control valve and at least one air charging valve are preferably mounted on top of each floatation unit to released or trapped the air inside the floatation units charging or releasing air inside the floatation unit will make the entire turbine housing and floatation assembly float or sink, or to float under water at whatever depth is so required.

[0039] To prevent a mounted turbine's alternator/generator, accessories, electrical controls, and other components from the hazards of the elements, a weatherproof shell may be provided, preferably supported by hinges and latches lock the shell in place when closed. A retractable hydraulic jack is preferably connected to the shell at one end, with the other end anchored to the ground level to provide a method of hydraulically opening and closing the shell as it is required. The shell in the closed position preferably provides an air space to prevent water from reaching water sensitive areas while the turbine is operating under water with shell closed and locked.

[0040] In the submerged position the air relief valve is preferably closed. Water is present inside the floatation unit, partly or completely occupying the space inside it, depending at which depth it is desired to float. When compressed air is re-introduced through the air charging valves into the floatation unit, the air entering inside the floatation unit preferably pushes the water inside it out through the open lip at the bottom of the floatation unit to make the turbine housing and floatation assembly float at any desired depth.

[0041] To hold the turbine housing and floatation unit at approximately the same location in the area, steel chains/cables with calculated slack are preferably attached to at least two anchors located at two different positions on the seabed. Attached to the fore is at least one anchor chain/cable, aft of the turbine housing and floatation assembly the other anchor chain/cable is/are attached. Thus the turbine housing and floatation assembly is preferably tethered at both fore and aft and is allowed to move forward or backward only depending on the direction of the tide flow and is prevented to turn around, dictated by the cable/s slack, to avoid fouling of the electrical cables. Thus, the opening

of the turbine housing will preferably be facing against the flow of the fluid and will be self adjusting in relation with the fluid flow, regardless of where the fluid flow is coming from.

[0042] According to a second aspect of the invention, there is provided a turbine housing as described hereinabove on which is mounted a turbine or rotatable shaft.

#### BRIEF DESCRIPTION OF THE DRAWINGS

[0043] For a better understanding of the invention, and to show how embodiments of the same may be carried into effect, preferred embodiments will now be described with reference to the accompanying diagrammatic drawings in which:

[0044] FIG. 1 illustrates a top view of a first preferred embodiment of the turbine housing of the invention.

[0045] FIG. 2 illustrates an isometric view of the preferred embodiment of the turbine housing shown in FIG. 1.

[0046] FIG. 3 illustrates a top view of a second preferred embodiment of the turbine housing shown in FIG. 3.

[0047] FIG. 4 illustrates an isometric view of the second preferred embodiment of the turbine housing of the invention.

[0048] FIG. 5 illustrates a perspective view of a floatation assembly of the third preferred embodiment of the turbine a of the invention.

[0049] FIG. 6 illustrates a perspective view of the turbine housing and floatation assembly of the third preferred embodiment shown in FIG. 5, when the turbine housing is mounted in the floatation assembly with the shell close.

[0050] FIG. 7 illustrates a perspective view of the turbine housing and floatation assembly of the third preferred embodiment shown in FIGS. 5 and 6, when the turbine housing is mounted in the floatation assembly with the shell open.

[0051] FIG. 8 illustrates a side view of the turbine housing and floatation assembly of the third preferred embodiment of the present invention, afloat and anchored on the sea bed with shell open.

[0052] FIG. 9 illustrates a side view of the turbine housing and floatation assembly of a fourth preferred embodiment of the present invention, submerged and anchored on the sea bed with the shell closed.

[0053] FIG. 10 illustrates a top view of a vertical access turbine of the prior art, in relation with the present invention showing the forces generated by the incoming fluid on the blades/buckets as the blades/buckets advances against the moving fluid.

#### DETAILED DESCRIPTION OF THE PREFERRED EMBODIMENT OF THE INVENTION

[0054] Referring firstly to FIG. 1 and FIG. 2, a preferred embodiment of a turbine housing 2, comprises a hollow housing body comprising a turbine housing portion 4, two conducting duct portions 6 and 10, an inlet portion 8 and outlet portion 12, having a bore running therethrough. The turbine housing portion 4 and two conducting duct portions 6 and 10 form a central portion of the housing 2. The two

portions 8 and 12 form the first and second ends of the housing. The cross-section of the turbine housing 2 is rectangular in this example, but could also either be square, oval, or circular, for example. The housing comprises a first end 32 and a second end 58 having a bore of a first larger cross-section tapering to a second smaller cross-section in the bore of the units 4, 6 and 10.

[0055] The turbine housing portion 4 is a hollow box open at both ends with a removable top plate 60. The removable top plate 60 is the access when installing turbine 62 inside this box. It is provided with inside double walling 14 along each side, mounted perpendicular from the bottom plate 16, originating and attached vertically to the turbine housing portion 4 opening flange 18 and flange 20 of the turbine housing portion 4. The shape of the double walling 14 is half an ellipse reckoned from the top view, the two vertical walling 14, together forms a venturi.

[0056] At the center of top plate 60 and bottom plate 16, the top and bottom bearing support (not shown) of a turbine shaft 22 of the vertical axis turbine 62 is located. Proper clearances are provided between double wall 14 and the blades of the rotating turbine 62.

[0057] The conducting duct portions 6 and 10 are just ducts or boxes open at both ends. The conducting duct portions 6 and 10 joins the turbine housing portion 4 flanges 18 and 20 as against flanges 24 and 38 of the conducting duct portions respectively. Both the other end of the conducting duct portions 6 and 10 joins the inlet and outlet portions 8 and 12 flanges 28 and 30 respectively. The inlet and outlet portions 8 and 12 comprise a first larger cross-section at the first end 32 and second end 58 tapering to a smaller cross-section in the central portion of the housing 4, both have a wide flaring end 32 and 58 that serves as an enlarged opening for intake or exhaust for the fluid during operation.

[0058] Use of the preferred embodiment of FIGS. 1 and 2 will now be described.

[0059] The whole turbine housing 2 is submerged and oriented into a free moving fluid such that the opening hole 32 of the inlet unit 8 is directly facing the incoming fluid, the fluid enters the opening hole 32, progresses inside and come out of the opening 58 to join the fluid flow passing outside the turbine housing 2.

[0060] During operation, when the fluid enters opening 32, the fluid progresses inside the inlet portion 8. The cross-sectional area of the bore is gradually reduced from the inlet 8 through the conducting unit portion 6 to accelerate to increase the fluid speed. The fluid is then delivered and enters into the conducting duct portion 6 to smoothen the fluid flow before it is allowed to enter the turbine housing portion 4. The venturi inside the turbine housing portion 4 further increases the fluid speed delivered by the conducting duct portion 6; at this maximum fluid speed, power is extracted.

[0061] The high-speed linear motion of the fluid inside the turbine housing portion 4 is converted by the turbine 62 into rotational motion of shaft 22, and is transmitted to a gearbox 50, which amplifies the rotational speed, then is transmitted to an alternator 52 that convert the forces into electrical output.

[0062] The fluid, after hitting the blades of turbine 12, is allowed to reduce speed as the fluid passes through the

venturi's throat inside the turbine housing portion 4. The fluid is then smoothen inside the conducting duct portion 10 before it enters the outlet unit 12. The progressively widening area of the bore inside the outlet unit 12, reduces the fluid speed further as it continue to pass into the outlet unit 12. The fluid coming out at opening 58, once again joins the flow of fluid passing outside the turbine housing 2.

[0063] Thus, the use of the turbine housing 2 increases the prevailing fluid speed outside the turbine housing 2, to produce an increase of available power for prime mover's extraction.

[0064] The process is reversed when the fluid flow changes its direction, this time, entering through opening 58 of the outlet unit 12, to come out through opening 32 of the inlet unit 8.

[0065] Use of the preferred embodiment of FIGS. 3, 4 and 10 will now be described.

[0066] Referring now to FIGS. 3 and 4, a second embodiment of the turbine housing 2, includes all the elements of the embodiment described for FIGS. 1 and 2, but also includes means to manage the fluid flow entering the turbine housing portion 4, in the foprm of fluid flow restriction means in the form of plates 34 and 40 installed inside the conducting duct portions 6 and 10. The fluid flow restriction means 34 and 40 are either straight rectangular plates, or are curvilinear plates, shaped to form a smooth curvature to guide, increase the speed, and direct the flow of the fluid. When the inlet portion 8 opening 32 is facing the fluid flow, the entering fluid increases in speed as it passes through the narrowing space of the bore of the inlet portion 8. The fluid enters the conducting unit 6, passing along the outward face 90 of the plate 34, the fluid speed increases further and is directed to hit the blades/buckets of turbine 62 where it is most needed, to produce optimum power extraction. Afterwards, the fluid speed is gradually reduced inside the turbine housing portion 4 as it progresses outward from the venturi's throat as a result of the venturis' effect of the double walling 14.

[0067] Inside the conducting duct portions 6 and 10 are pivot pins 46 and 48, arresting pins 42 and 44, used by the plates 34 and 40 respectively, as pivots and as closing travel arresters.

[0068] Downstream of the fluid flow restriction means at inner surface 92, the fluid path is blocked. The block produces a slower fluid speed encountered by the advancing blades/buckets of the turbine 62 resulting to a much lower subtractive forces; hence, much larger net power can be extracted.

[0069] The fluid output of the turbine housing portion 4 enters the conducting duct portion 10 to impinge on the inward face 56 of the fluid plate 40 that is resting against the arresting pin 44. The fluid plate 40 then slide open by the aid of rollers (not shown) attached at the bottom edge of the fluid plate 40, pivoting on the pivot pin 48. This allows the fluid to reduce speed some more, so it could now easily pass through the outlet portion 12, through opening 58, and be sucked by the mainstream fluid flowing outside the turbine housing 2.

[0070] When the tide flow reverses, fluid flow the fluid inside the fluid accelerator assembly 2 also reverses.

[0071] The now opened plate 40 will be impinged on the outward face 54 by the incoming fluid. Plate 40 then will be pushed to move inside towards the closed position, until the closing motion is stopped as the inward face 56 of the plate means 40 hits the arresting pin 44. The cycle will then keep repeating every time the direction of the fluid flow reverses.

[0072] Use of the preferred embodiment of FIGS. 5, 6, 7 and 8 will now be described.

[0073] Referring now to FIGS. 5, 6, 7, and 8, a third embodiment of the turbine housing 2 of the invention, includes all elements described in FIGS. 3 and 4, but include floatation assembly 80 to make the turbine housing 2 float. The floatation assembly 80, is composed of at least one floatation unit 82, preferably, at least two floatation units 82, separated by superstructure and flooring 84, such that when the two floatation units 82 are bolted and joined, the turbine housing 2, will be mounted to straddle the floatation assembly 80, sandwiching the whole body lengthwise. When bolted to the superstructure and flooring 84, the turbine housing 2 becomes an integral unit of the turbine housing and floatation assembly 94. Mounting is made such that, the turbine housing 2 is lower than the top of the superstructure and flooring 84, suitably to make it totally underwater while the super structure and flooring 84 is well above the water.

[0074] On top of the superstructure and flooring 84 is where the turbine gearbox 50, alternator 52, hydraulic jacks 70, compress air containers, compressors, hydraulic motors, electrical accessories and controls (all not shown) are located. All of these accessories are covered with a shell 64, such that when closed, hinges 66 and latch 68 holds the shell 64 in-placed shell 64 when close create a water tight chamber that protect the alternator 52 and other required accessories from getting wet, during fully submerged operation operation. The shell 64 is attached by hinges 66 to the superstructure and flooring 84 to allow shell 64 to be opened or closed at will, by means of hydraulic jack 70.

[0075] In use, when the turbine housing 2 and floatation assembly 94 is place on a free moving fluid such as a river or an oean, the turbine housing 2 and floatation assembly 94 will float. The whole superstructure 84 will be under the water surface except for the superstructure flooring 84, which houses the gearbox 50, alternator 52, together with the electrical accessories (not shown), are all above the water surface.

[0076] To prevent turbine housing 2 and floatation assembly 94 being carried by the flowing water, mooring chains 76 and 78 are attached to both fore and aft mooring blocks 86 and 88 embedded on the seabed. This mooring arrangement provide an ample means to allow the turbine housing 2 and floatation assembly 94 to move fore and aft only dictated by the direction of the water flow.

[0077] Referring now to FIGS. 8 and 9, the fourth embodiment of the invention includes all the elements of the embodiment described for FIGS. 5, 6, 7, and 8, but includes means to submerge the whole turbine housing and floatation assembly 94 to continuously operate; this time under the surface of the water.

[0078] At least one mechanically/electrically or pneumatically controlled discharge valve 72 and at least one mechanically/electrically or pneumatically controlled charging valve 74 is installed on the top surface of the floatation unit 82.



[0079] In use, during normal operating condition, except for the flooring 84, the rest of the floatation means assembly 80 is submerged under the water surface.

[0080] During bad weather condition water surface becomes rough. The continuously buffeting disturbances cause by the waves, disrupts the smooth operation of the system. To avoid the possibility of a mooring break or destruction, the whole turbine housing and floatation assembly 94 is required to submerge to a suitable water depth.

[0081] Before diving or under water operation is initiated, the shell 64 is close through the use of hydraulic jack 70 and held rigidly close by the aid of the latch 68 and hinges 66. The trapped air inside the airtight shell 64 prevents the water from reaching gearbox 50, alternator 52, and the rest of water sensitive instruments and controls.

[0082] At floating position, the trapped air inside the floatation unit 82 that makes the turbine housing and floatation assembly 94 float is vented out to the atmosphere through the mechanically/electrically or pneumatically controlled discharge valve 72. Allowing the release of the trap air inside the floatation unit 82, the space vacated by the air permits the water to enter through the open lip at the bottom of floatation unit 82. As the buoyancy is lost, the turbine housing and floatation assembly 94 starts to sink and be totally submerged. The desired water depth where the turbine housing and floatation assembly 94 is allowed to maintain is controlled by the amount or quantity of the trapped air released.

[0083] In the submerged position, with the discharge valve 72 closed, a battery of compressed air canisters (not shown) charges the floatation unit 82 through the charging valves 74. The water occupying the space inside the floatation unit 82 is forced out by the entering air, and the water is then pushed out through the open bottom at the lip of the floatation units 82. As the air space increases, the buoyancy of the turbine housing and floatation assembly 94 increases. The amount of air charged determines the level at which turbine housing and floatation assembly 94 will float.

[0084] The reader's attention is directed to all papers and documents which are filed concurrently with this specification in connection with this application and which are open for public inspection with this specification, and the content of all such papers and documents are incorporated herein by references. All of the features disclosed in this specification (including any accompanying claims, abstract and drawings), and/or all of the steps of any method or process so disclosed, may be combined in any combination, except combinations where at least some of such features and/or steps are mutually exclusive.

[0085] Each feature disclosed in this specification (including any accompanying claims, abstract and drawings), maybe replaced by alternative features serving the same, equivalent, or similar purpose, unless expressly stated otherwise. Thus, unless expressly stated otherwise, each feature disclosed is one example only of a generic series of equivalent or similar features.

[0086] The invention is not restricted to the details of the foregoing embodiment(s). The invention extends to any novel one, or any novel combination, of the feature disclosed in this specification (including any accompanying

claims, abstracts, and drawings), or to any novel one, or any novel combination, of the steps of any method or process so disclosed.

1. A turbine housing comprising a housing body having a first end, a second end and a central region, wherein the housing body comprises:

a bore running therethrough, and wherein the bore tapers from a first larger cross-section at and/or in the region of the first and second ends to a second, smaller cross-section towards the central region; and

fluid flow restriction means comprising two moveable members, one each located towards the first and second end of the housing, and arranged such that one of the first and/or second fluid flow restriction means moves to the first position when the other of the second and/or fluid flow restriction means moves to the second position.

2. A turbine housing as claimed in claim 1 wherein the cross-section of the bore in the central portion is selected from the group of shapes consisting of rectangular, cylindrical, oval or square.

3. A turbine housing as claimed in claims 1 or 2 wherein the shape of the first and second end is selected from the group of shapes consisting of frusto-conical, frusto-pyramidal or trumpet shaped.

4. A turbine housing as claimed in claims 1 or 2 wherein the cross-sectional shape of the central portion of the housing is selected from the group of shapes consisting of rectangular or square, and the shape of the first and second end comprises a flared extension of the rectangular or square cross-sectional shape of the central portion of the housing.

5. A turbine housing as claimed in claim 1 wherein the first and second end comprise a fluid inlet and a fluid outlet respectively.

6. A turbine housing as claimed in claim 1 wherein the central portion of the housing comprises means to house a turbine or a rotatable shaft of the turbine.

7. A turbine housing as claimed in claim 6 wherein the central portion of the housing comprises a bore of uniform cross-section, and suitably the means to house a turbine or rotatable shaft if located substantially centrally within the central portion.

8-9. (canceled)

10. A turbine housing as claimed in claim 1 wherein the fluid flow restriction means restricts speed and/or direction of fluid flow through the housing.

11-13. (canceled)

14. A turbine housing as claimed in claim 1 further comprising a movement limiting means operably co-operable with the means to restrict fluid flow, such that the means to restrict fluid flow is limited between the first and second positions only.

15. A turbine housing as claimed in claim 14 wherein the movement limiting means comprises an arresting pin which serves to prevent the movement limiting means from restricting fluid flow from moving out of the range of the first and second positions.

16. A prime mover comprising a turbine housing as claimed in claim 1, on which is mounted a turbine.

17. A prime mover as claimed in claim 16 further comprising means to connect the turbine housing to a fixed structure.

**18.** A prime mover as claimed in claim 17 wherein the means to connect the turbine housing to a fixed structure comprises means to connect the turbine housing to an ocean, river or sea bed.

**19.** A prime mover as claimed in claim 18 mounted within a floatation unit, arranged in use to enable the prime mover to float in a fluid medium.

**20.** A prime mover as claimed in claim 19 wherein the floatation unit comprises means to enable entrapment of air within the floatation unit and means to enable control of

release of air trapped within the floatation unit to enable the prime mover to float or sink in a fluid medium to a desired depth.

**21.** A prime mover as claimed in claim 19 or 20 wherein the floatation unit further comprises a waterproof shell, arranged in use to protect a mounted turbine's electrical components from the fluid medium.

\* \* \* \* \*