



(19) **United States**

(12) **Patent Application Publication**
Maris et al.

(10) **Pub. No.: US 2006/0272418 A1**

(43) **Pub. Date: Dec. 7, 2006**

(54) **OPTO-ACOUSTIC METHODS AND APPARATUS FOR PERFORMING HIGH RESOLUTION ACOUSTIC IMAGING AND OTHER SAMPLE PROBING AND MODIFICATION OPERATIONS**

(52) **U.S. Cl. 73/606**

(57) **ABSTRACT**

(75) Inventors: **Humphrey J. Maris**, Providence, RI (US); **Arto V. Nurmikko**, Providence, RI (US)

One aspect of the present invention concerns scanning acoustic microscopes in which sound waves used for imaging purposes are generated by an opto-acoustical process. A scanning acoustic microscope of the present invention includes an opto-acoustic transducer assembly having a substrate. Formed in the substrate of the opto-acoustic transducer assembly is a layer of opto-acoustic material. When pulsed light waves impinge the layer of opto-acoustic material, pulsed sound waves are created. An acoustic lens also formed in the substrate focuses the pulsed sound waves which are then used to probe the physical and mechanical properties of a sample object. Pulsed sound waves reflecting off the sample object return to the opto-acoustic transducer where the pulsed sound waves impinge the layer of opto-acoustic material. The impinging sound waves change at least one optical property of the layer of opto-acoustic material. This change, which is dependent on changes to the pulsed sound waves caused by the interaction of the pulsed sound waves and the sample object, is then sensed using pulsed light waves. In one possible embodiment of the present invention, the layer of opto-acoustic material is deposited on the substrate in a plurality of non-contiguous concentric rings. The plurality of non-contiguous concentric rings operates as an acoustic analogue of a Fresnel lens.

Correspondence Address:
HARRINGTON & SMITH, LLP
4 RESEARCH DRIVE
SHELTON, CT 06484-6212 (US)

(73) Assignee: **Brown University**

(21) Appl. No.: **11/274,628**

(22) Filed: **Nov. 14, 2005**

Related U.S. Application Data

(60) Provisional application No. 60/687,070, filed on Jun. 3, 2005.

Publication Classification

(51) **Int. Cl.**
G01N 29/04 (2006.01)

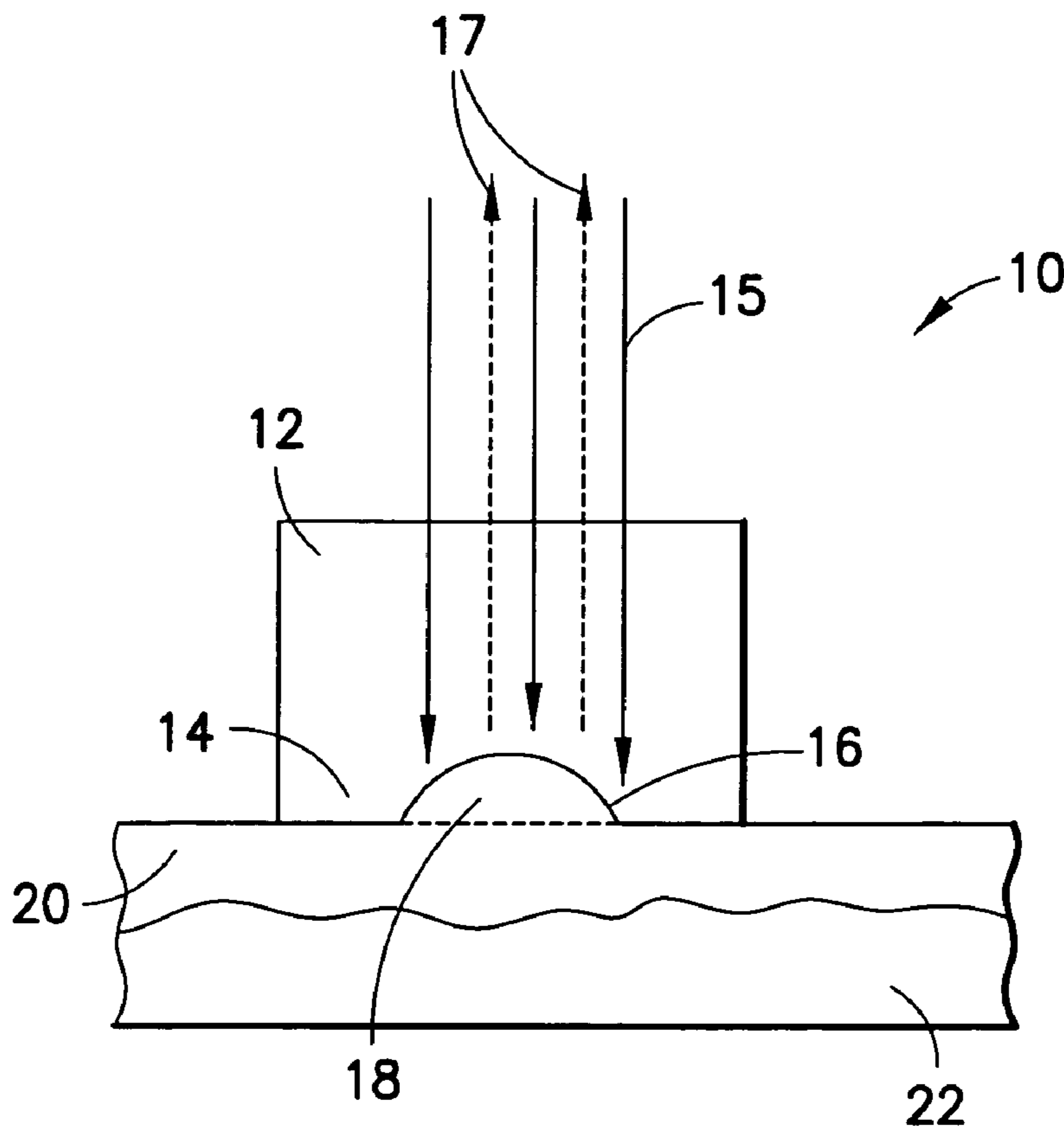

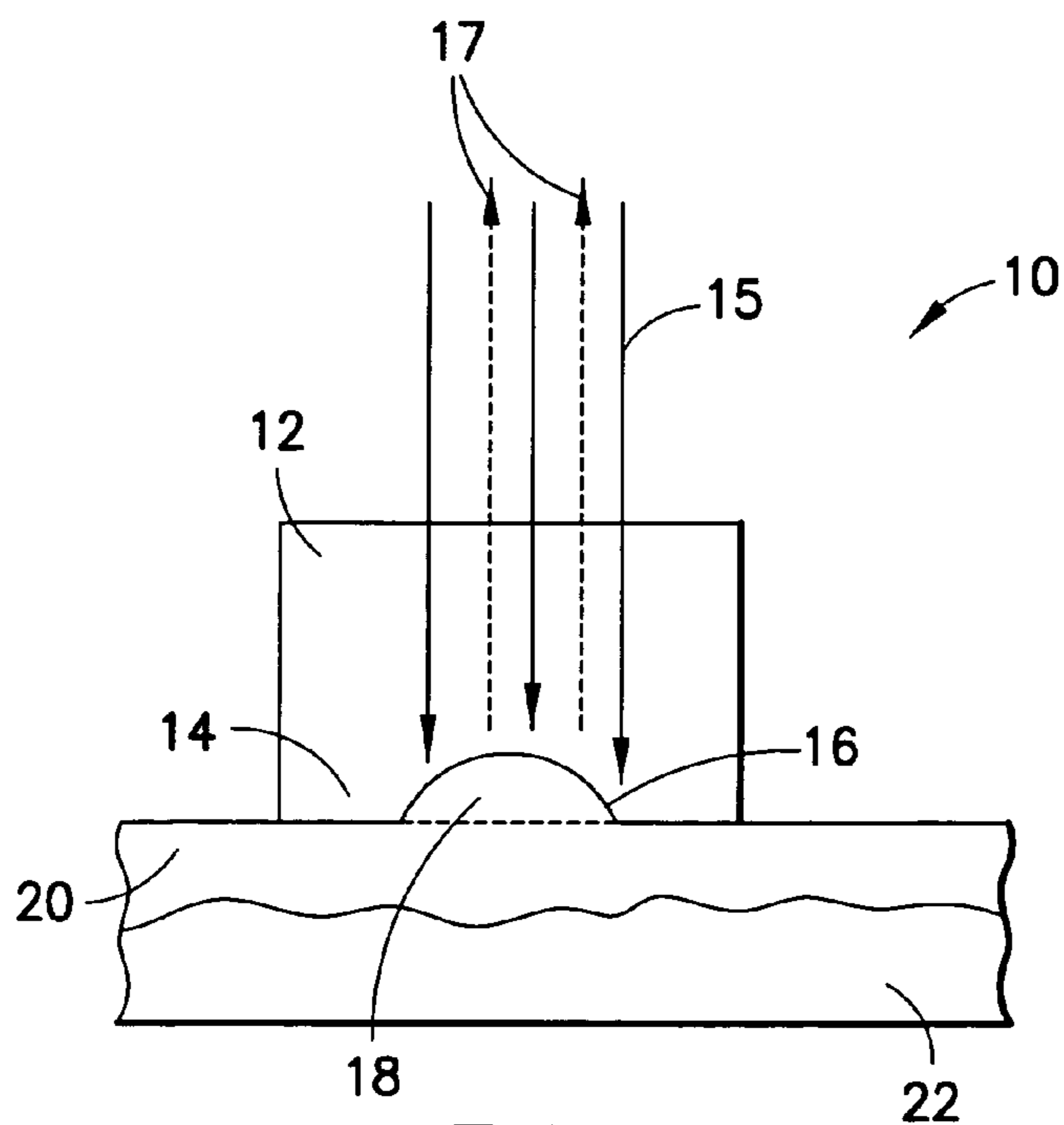

FIG. 1

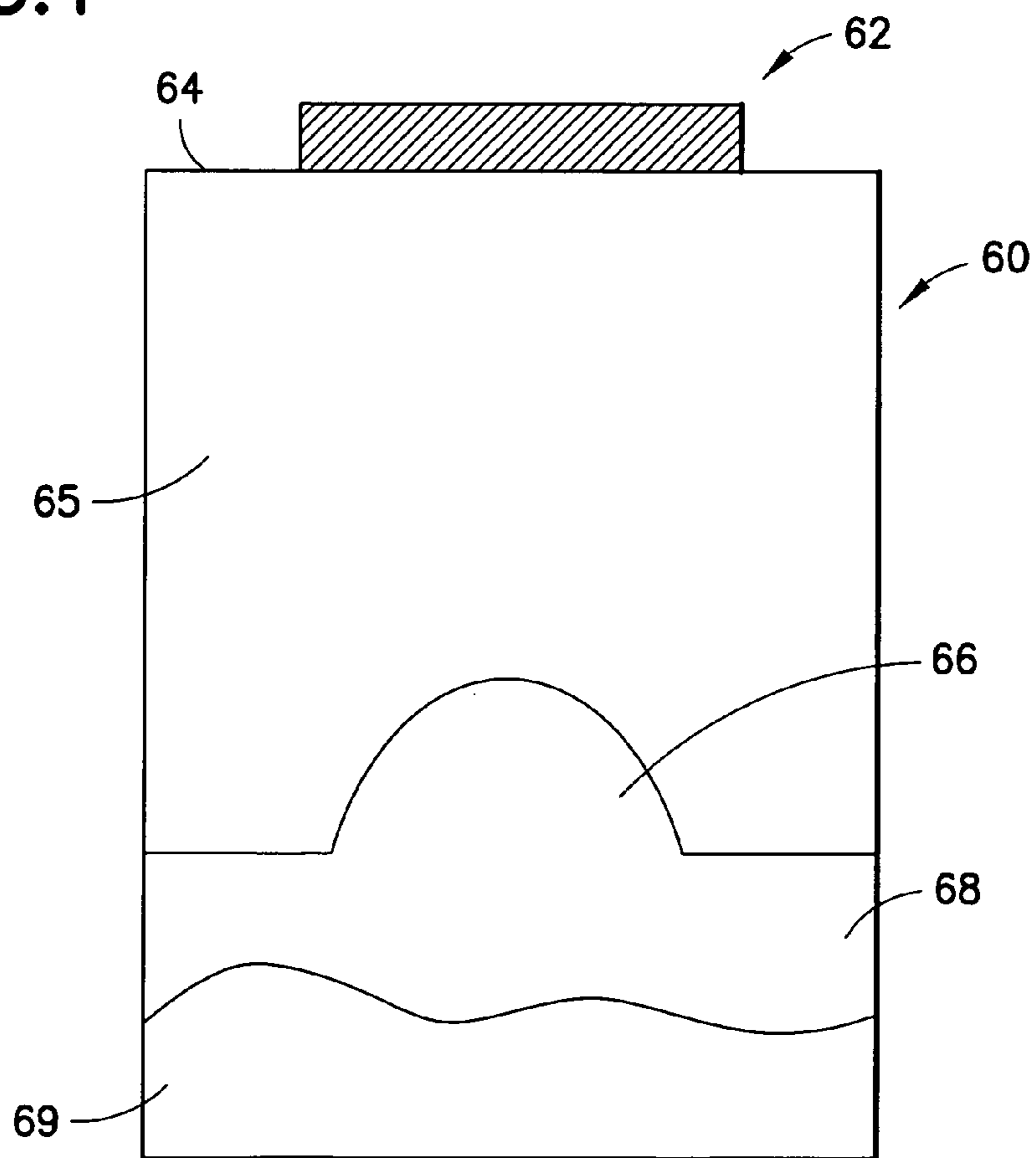

FIG. 3

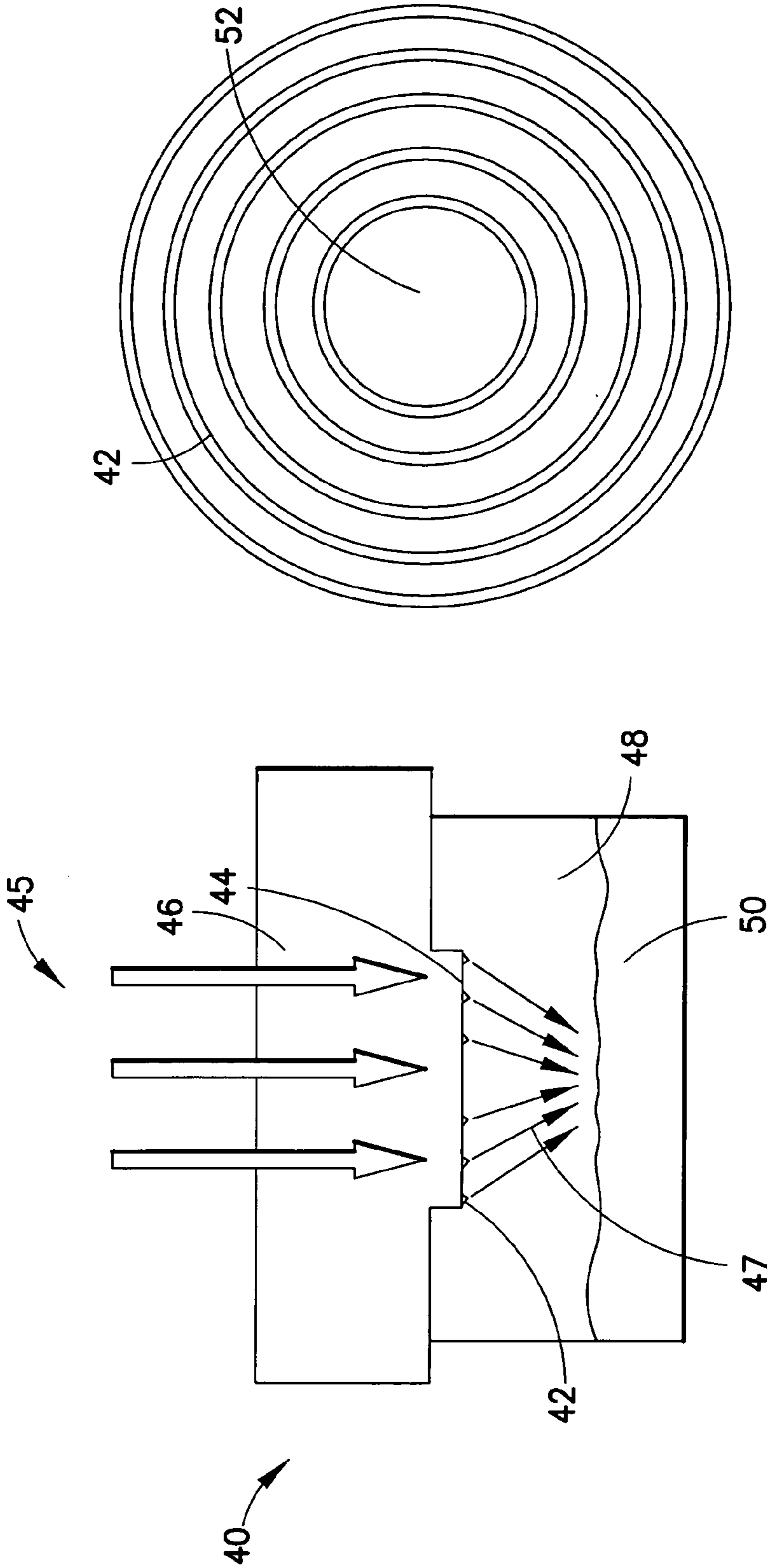

FIG. 2B

FIG. 2A

FIG. 2

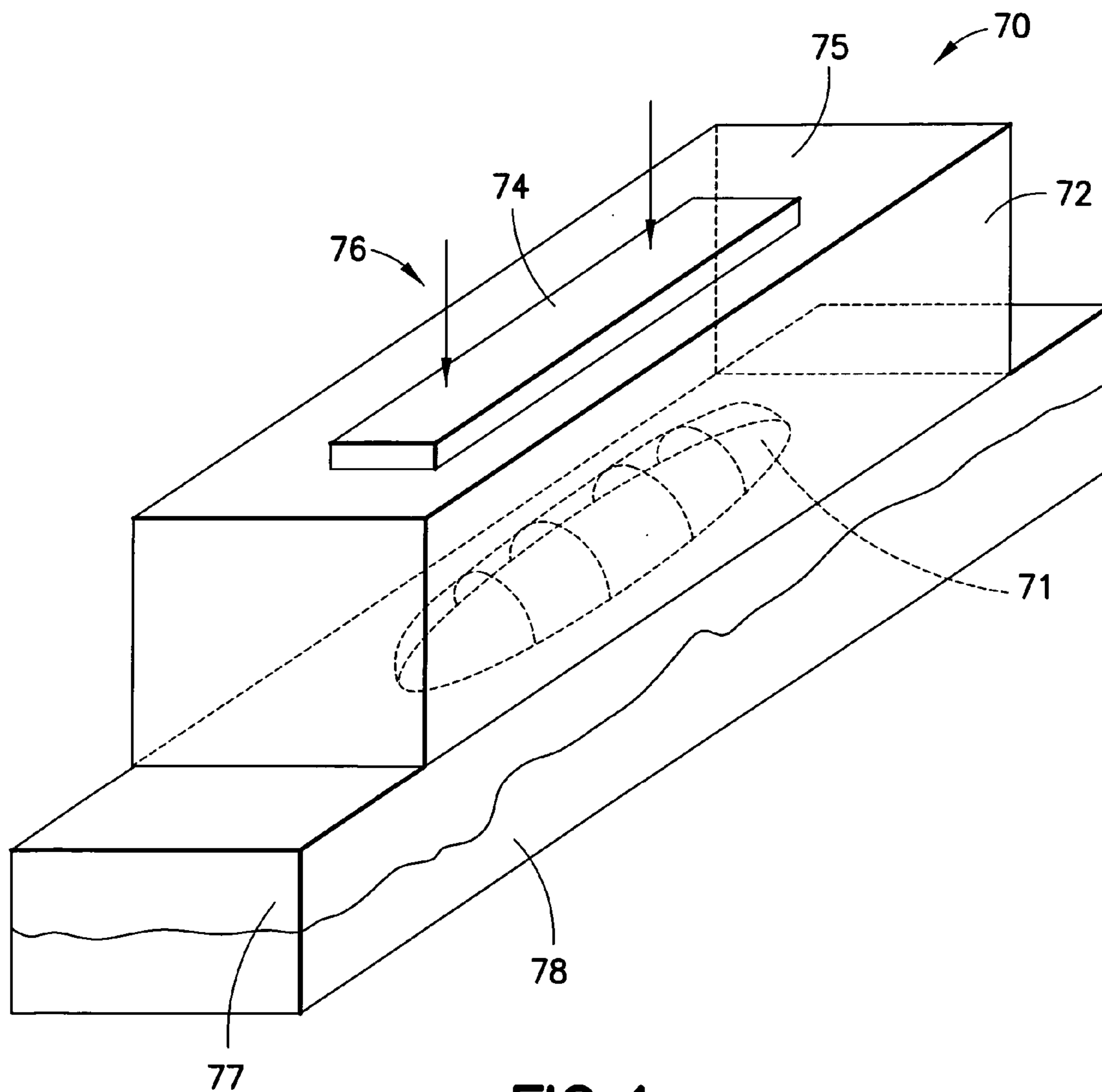

FIG. 4

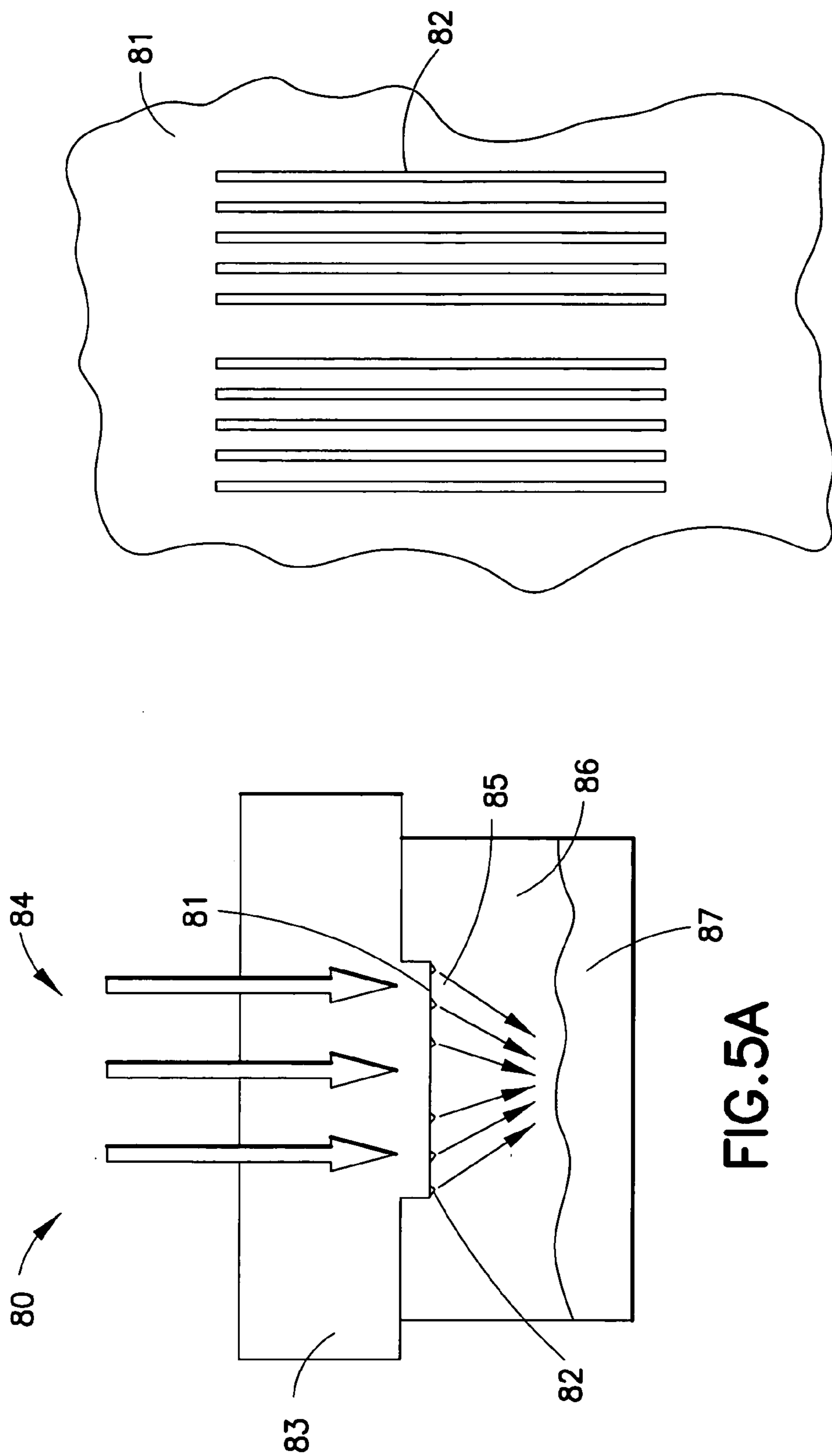

FIG. 5B

FIG. 5A

FIG. 5

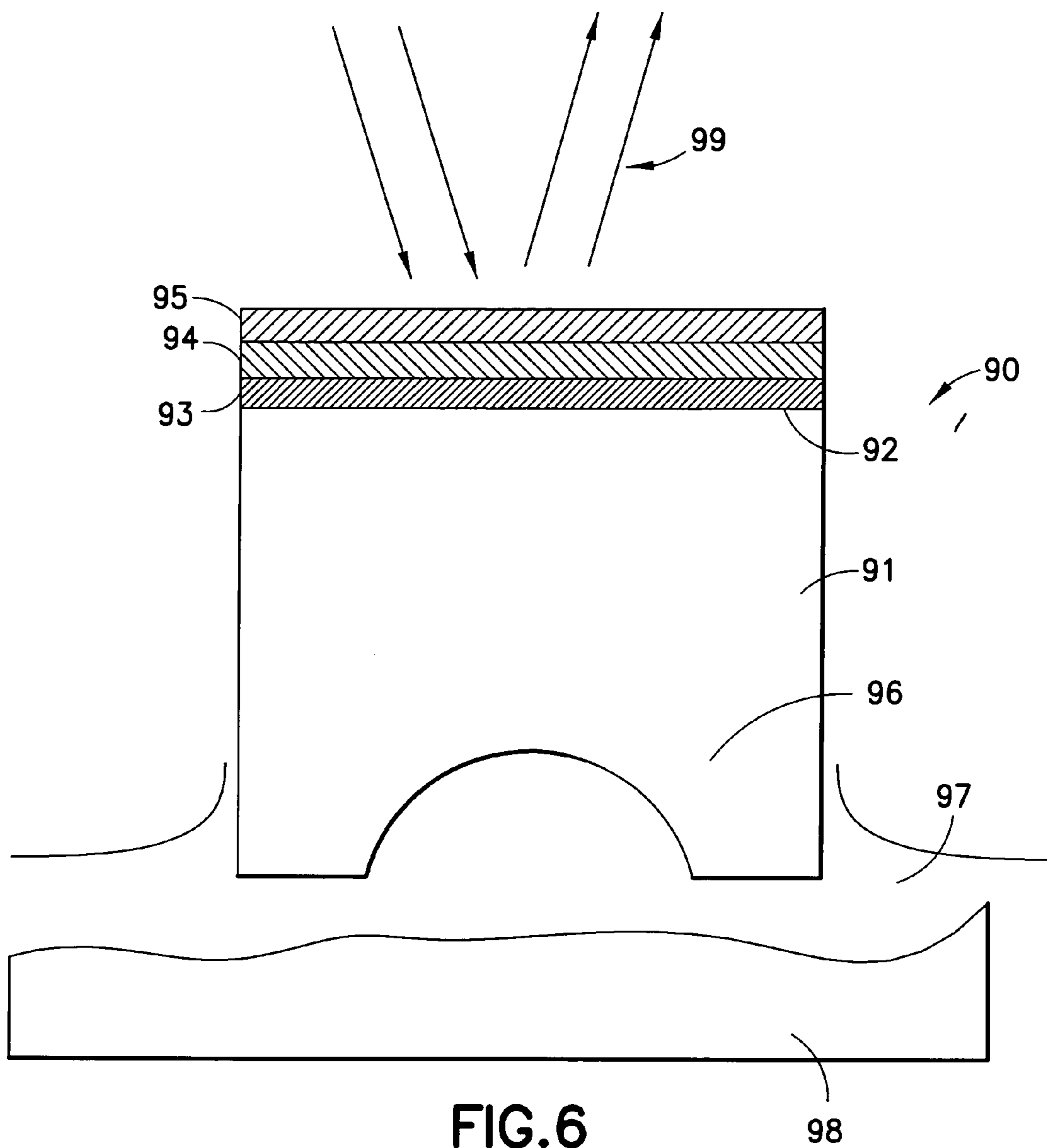

FIG. 6

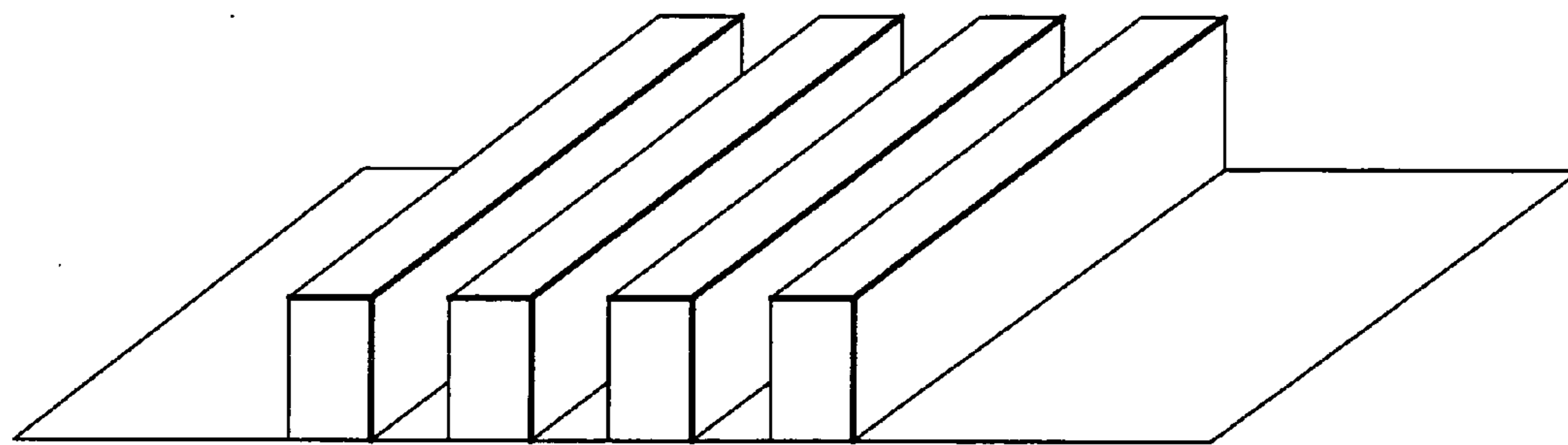

FIG. 9

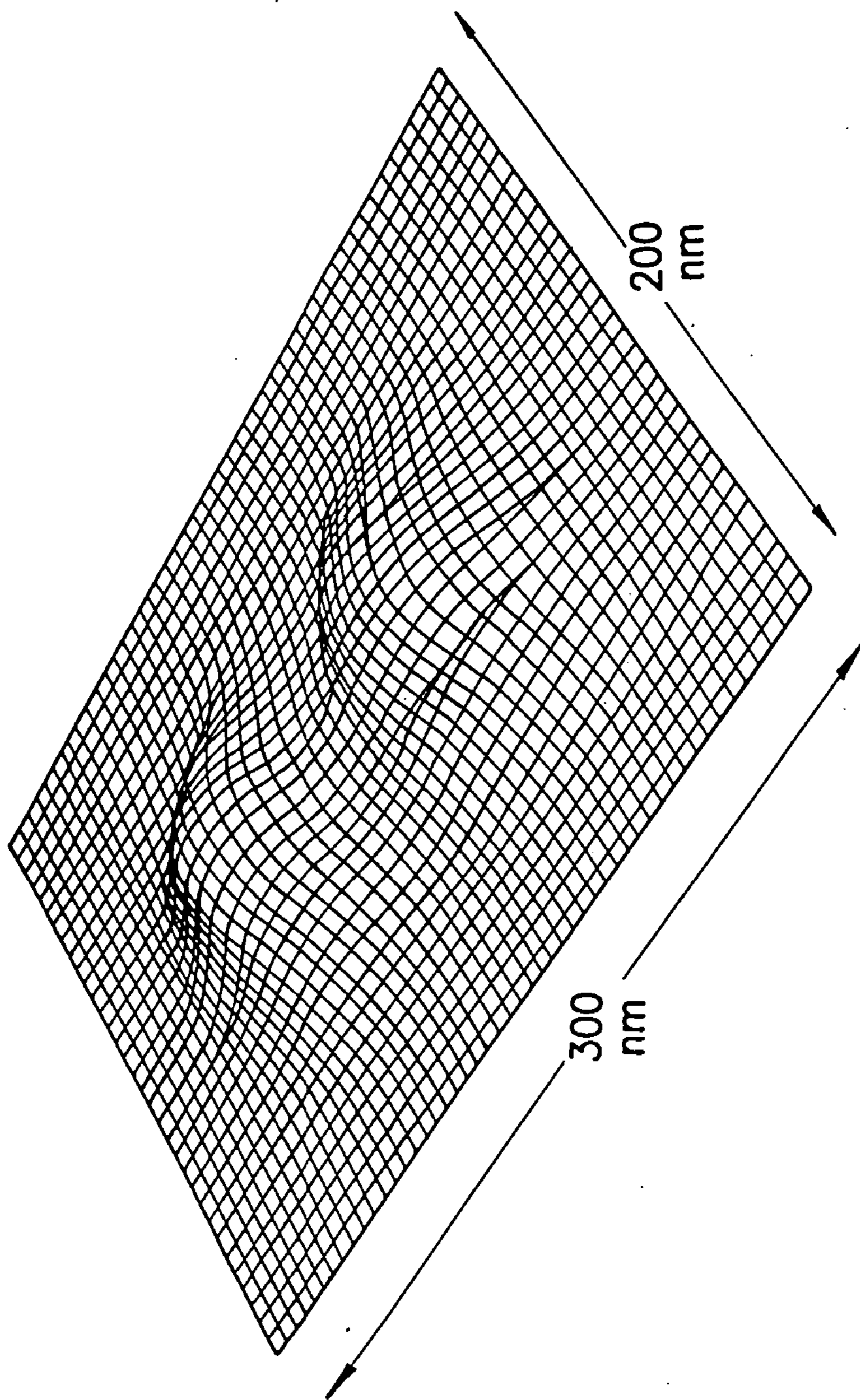

FIG. 7

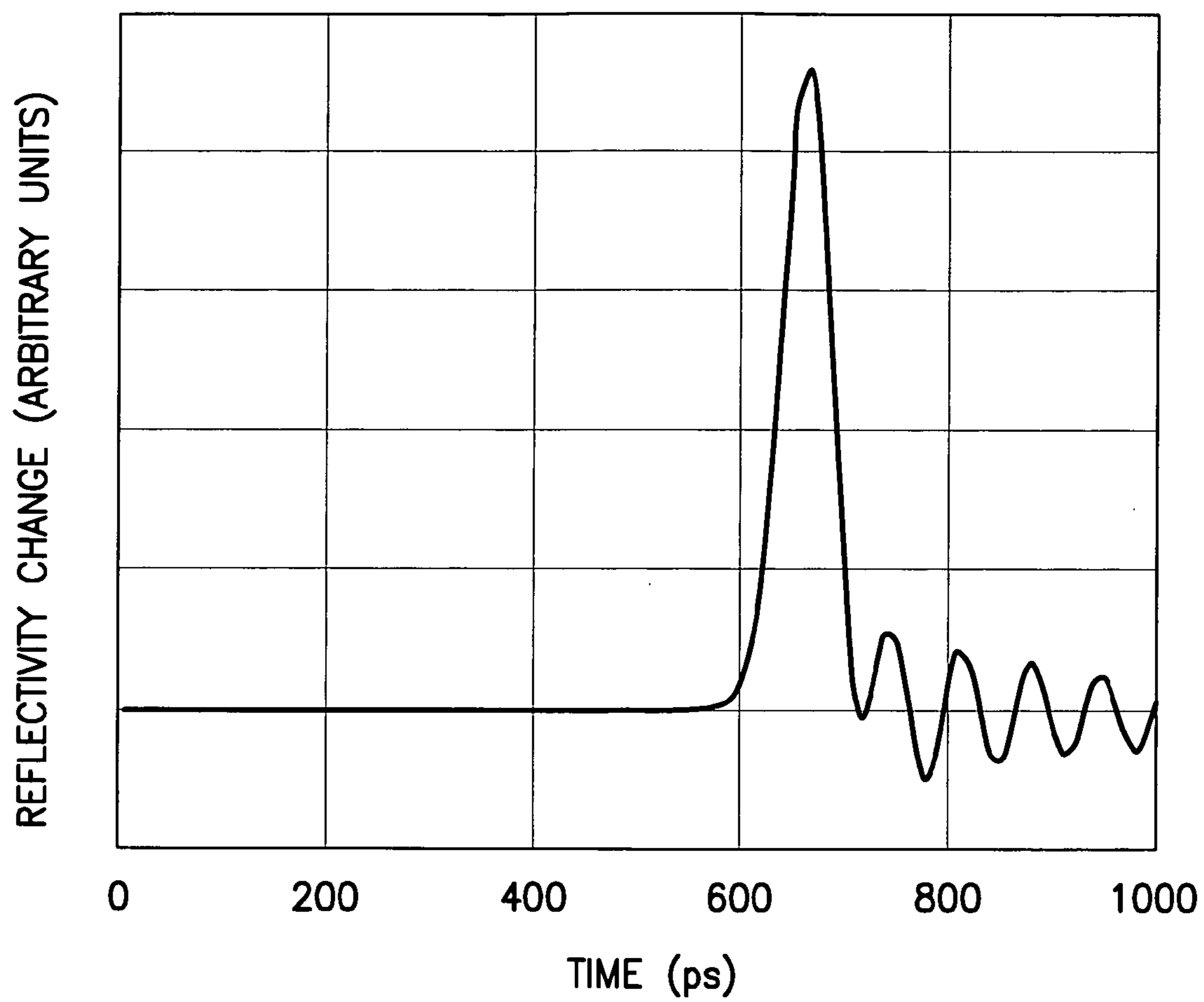

FIG.8

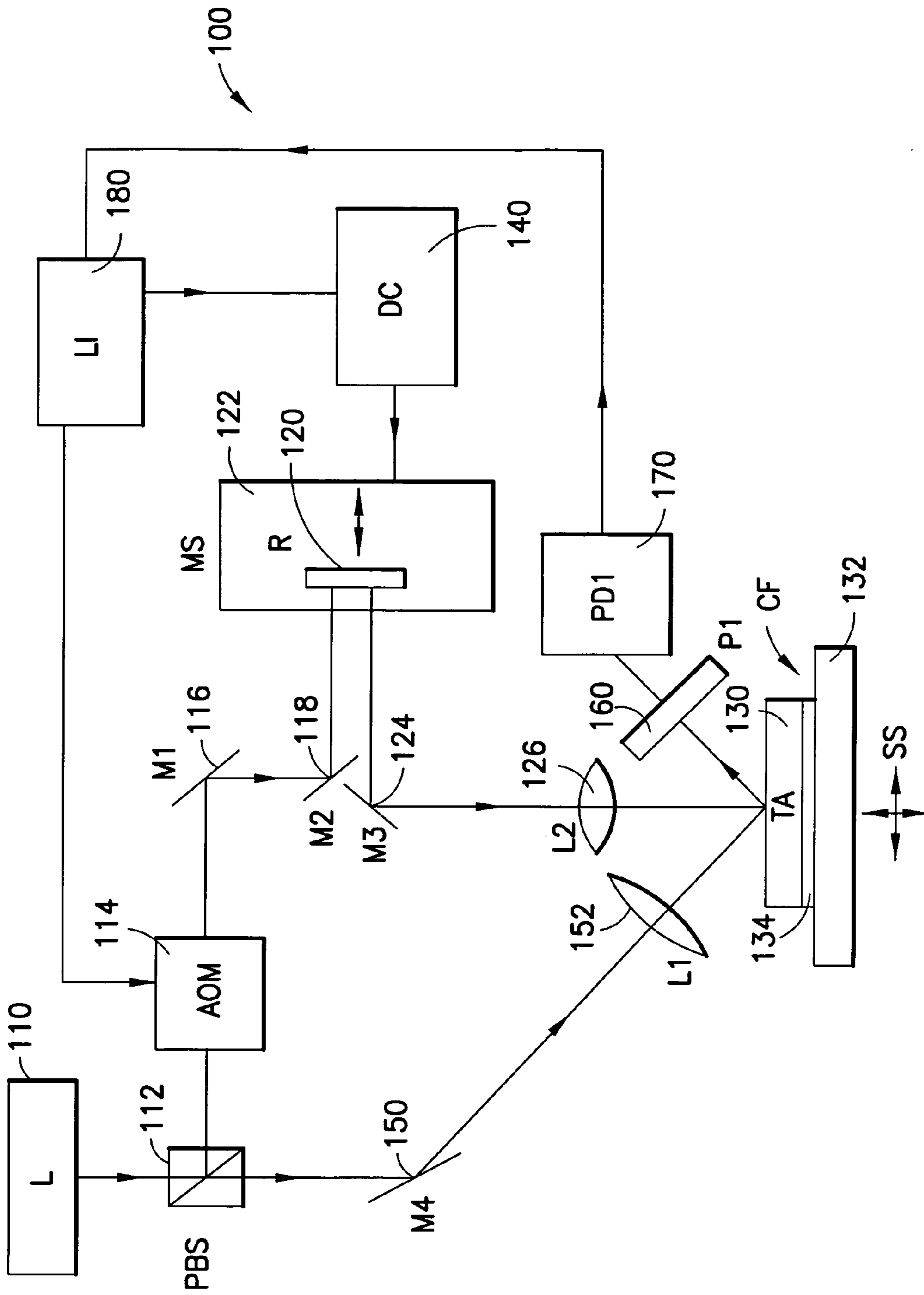

FIG.10

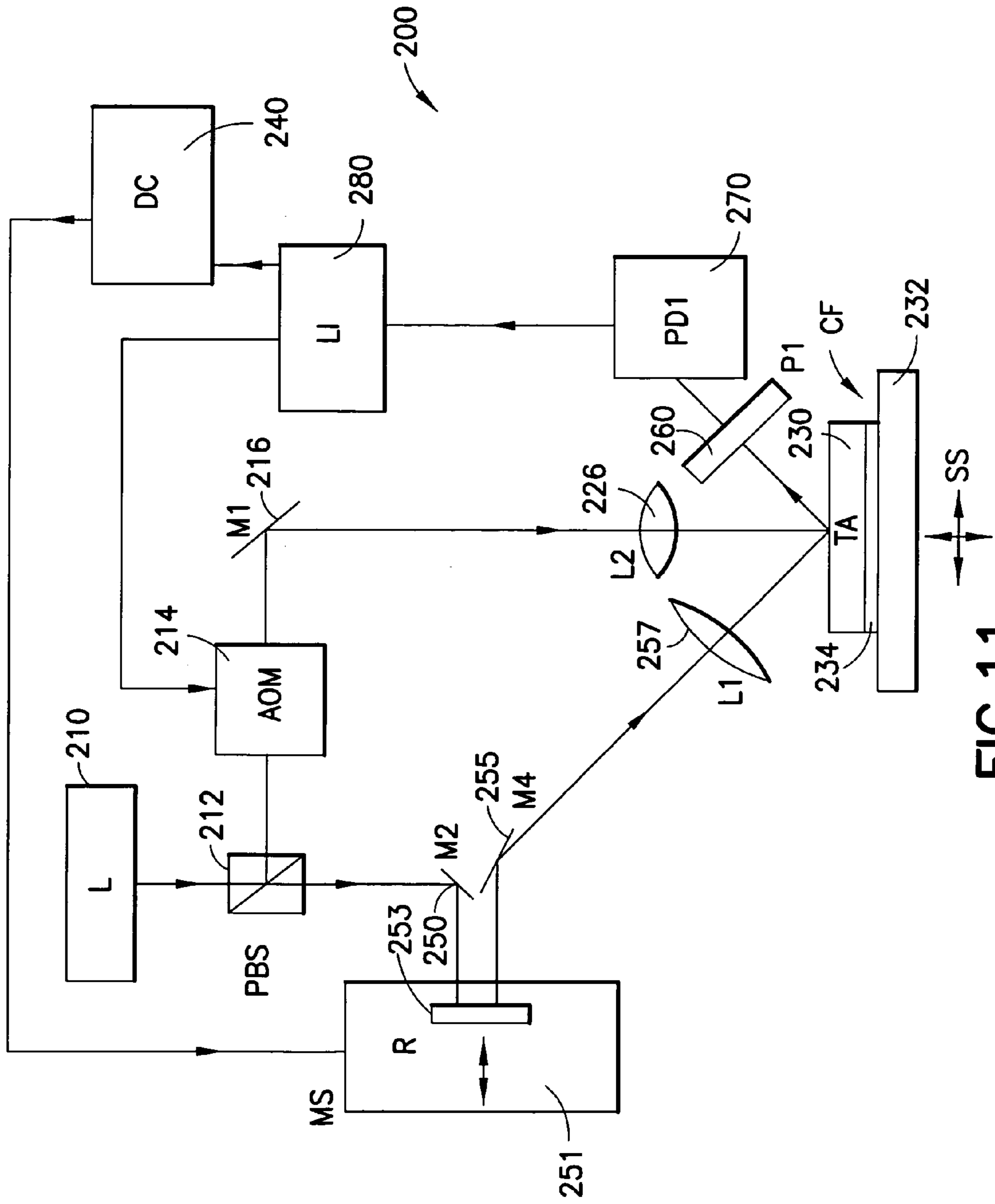

FIG.11

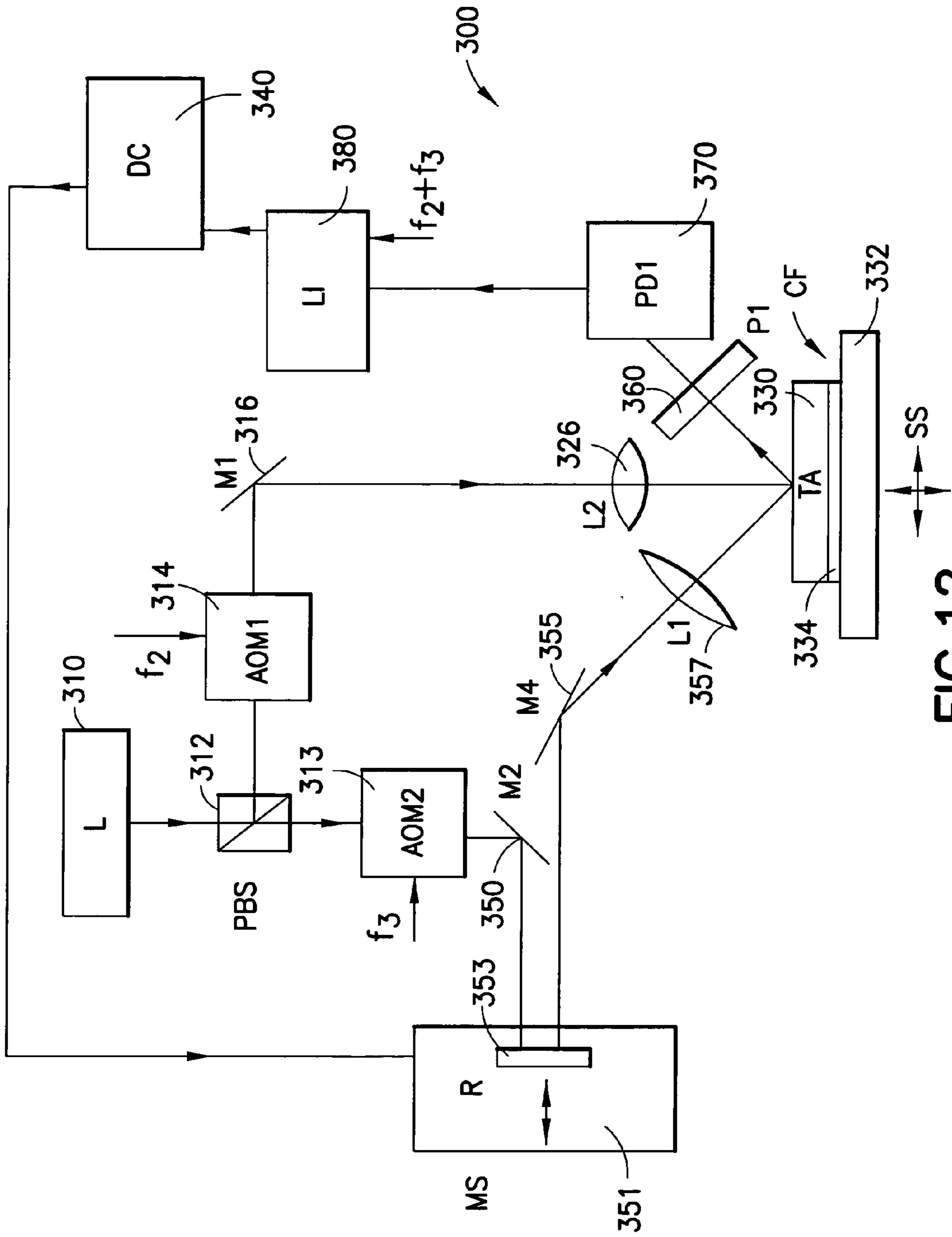

FIG.12

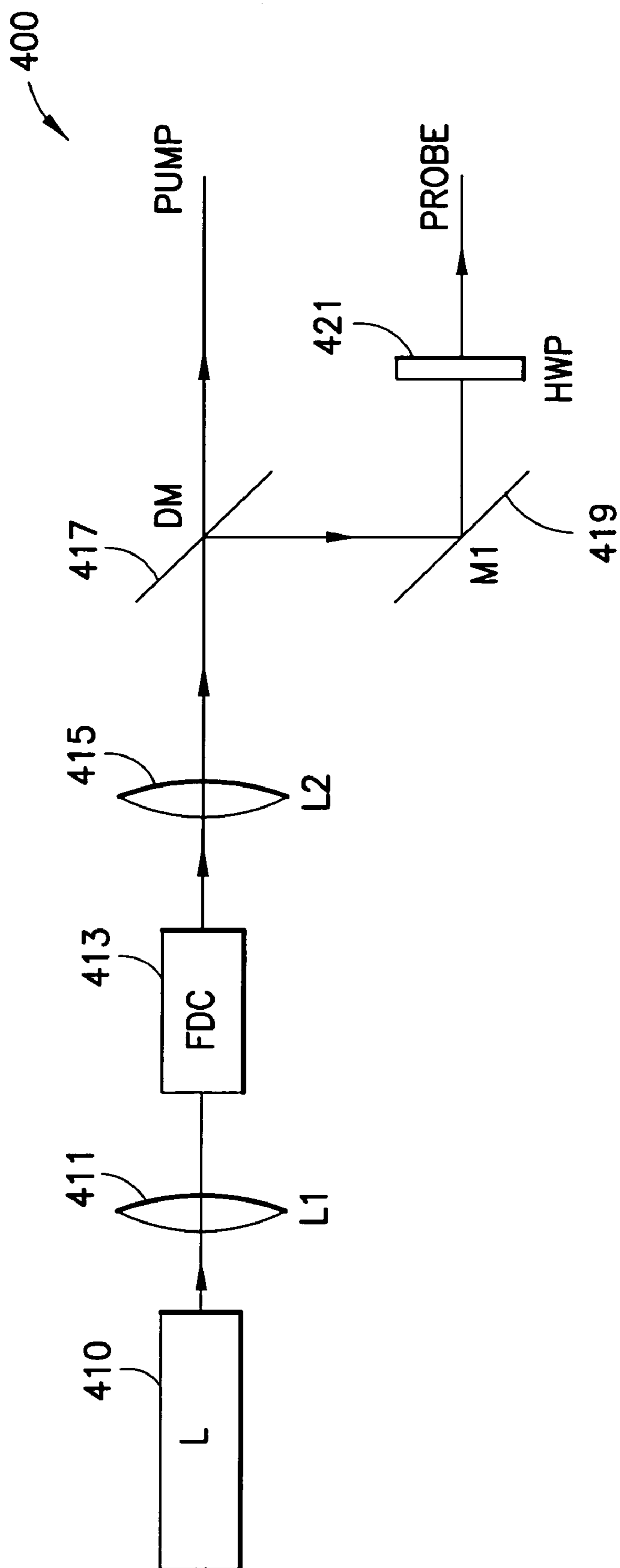

FIG.13

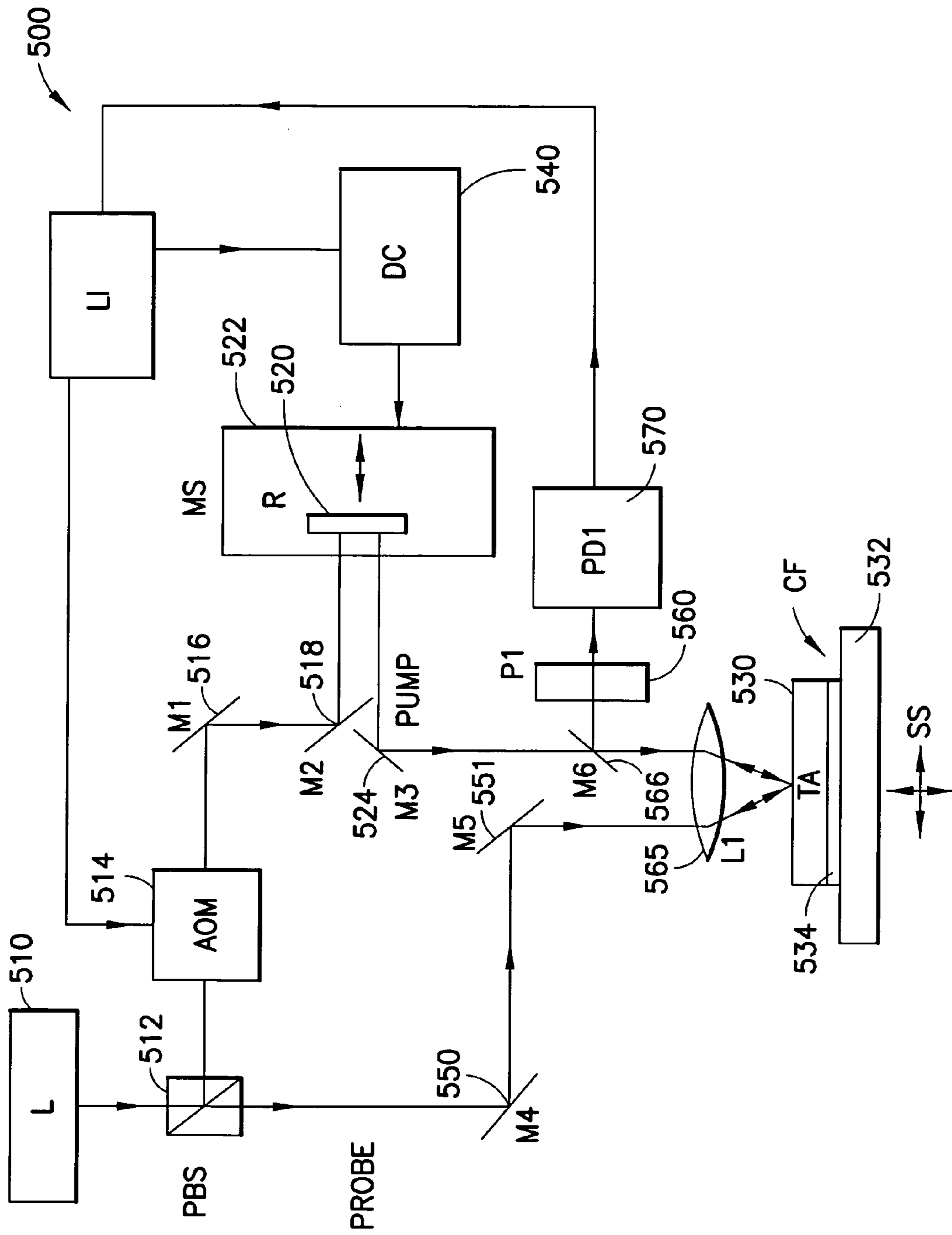

FIG.14

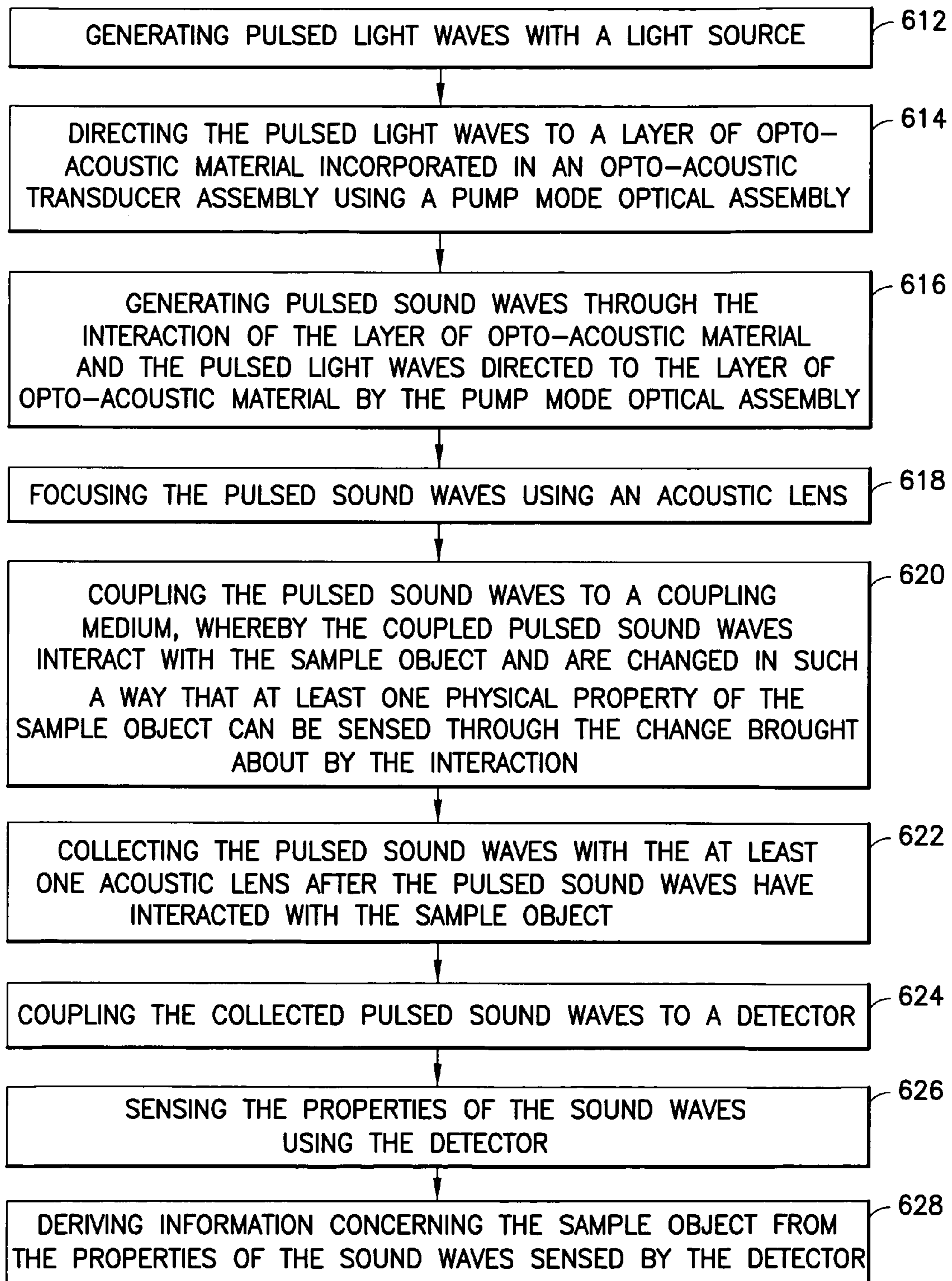

FIG. 15

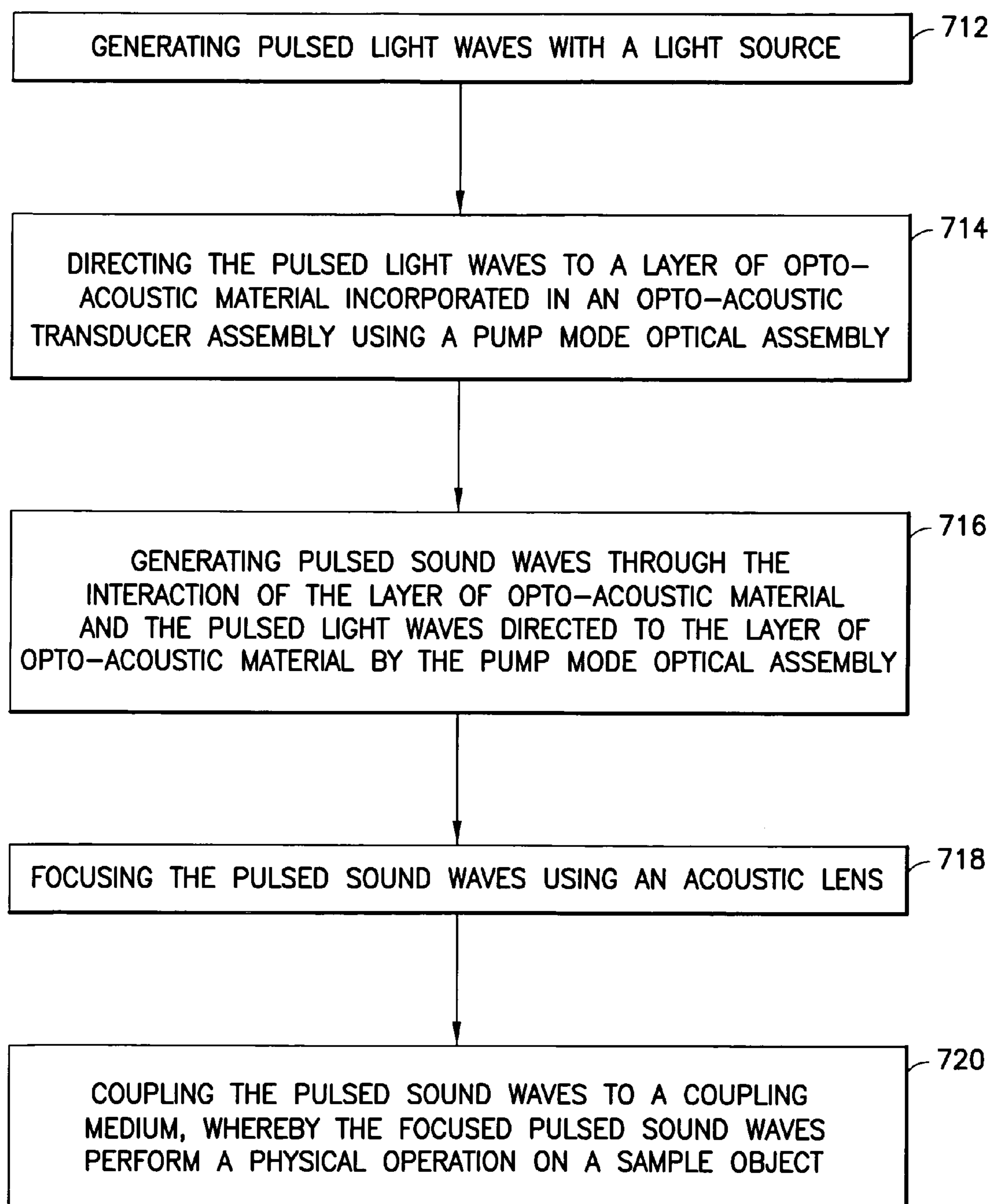

FIG.16

**OPTO-ACOUSTIC METHODS AND APPARATUS
FOR PERFORMING HIGH RESOLUTION
ACOUSTIC IMAGING AND OTHER SAMPLE
PROBING AND MODIFICATION OPERATIONS**

CLAIM OF PRIORITY FROM A CO-PENDING
PROVISIONAL PATENT APPLICATION

[0001] Priority is herewith claimed under 35 U.S.C. § 119(e) from co-pending Provisional Patent Application 60/687,070, filed on Jun. 3, 2005 by Humphrey J. Maris and Arto V. Numikko entitled “OPTO-ACOUSTIC METHODS AND APPARATUS FOR PERFORMING HIGH RESOLUTION ACOUSTIC IMAGING AND OTHER SAMPLE PROBING AND MODIFICATION OPERATIONS”. The disclosure of this Provisional Patent Application is hereby incorporated by reference in its entirety as if fully restated herein.

STATEMENT OF GOVERNMENT RIGHTS

[0002] The invention was made in part under United States Air Force Office of Scientific Research MURI Grant entitled “Phonon Enhancement of Electronic and Optoelectronic Devices” (Grant No. F4962-00-1-0331), and National Science Foundation Grant entitled “Nucleation Processes in Liquid Helium” (Grant No. DMR 03-05115). Accordingly, the Government has certain rights in this invention.

TECHNICAL FIELD

[0003] The present invention generally concerns methods and apparatus suitable for use in instruments in which sound waves are used to perform imaging operations, and more particularly concerns instruments such as, for example, scanning acoustic microscopes, in which sound waves used to perform imaging and other sample probing operations are generated by an opto-acoustic process.

BACKGROUND

[0004] In an acoustic microscope sound is generated in some way and then brought to a focus. The object to be studied is placed at or near the focus and an image of the object is obtained by moving the object laterally and monitoring the variation of the amplitude and phase of the acoustic waves that are reflected from the object or that are transmitted through the object. Instead of moving the object that is to be imaged, it is often preferable to hold the object in one place and vary the position of the acoustic focus. The position of the acoustic focus can be changed by moving the position of the lens used to focus the sound.

[0005] Conventional acoustic microscopes consist of a transducer to generate sound, and a lens to focus the sound, a coupling medium (usually water) through which the sound propagates to come to a focus, and the sample object. The sound reflected from the object may be collected by the same lens that is used to focus the incident beam or by another lens. To collect sound transmitted through the sample a collection lens is needed on the far side of the sample.

[0006] It is usually considered that the first scanning acoustic microscope was built by R. A. Lemons and C. F. Quate, (see “Acoustic Microscope—Scanning Version”, Appl. Phys. Lett. 24, 163 (1974)). This used a continuous acoustic wave of frequency 160 MHz, had a resolution of 10 μm , and worked in the transmission mode.

[0007] The resolution of an acoustic microscope is determined by the wavelength λ of the sound that is used and by the numerical aperture of the lens or lenses that are used. To achieve a high resolution, it is necessary to work at the highest possible frequency with a large numerical aperture. According to Briggs, p. 45, the best resolution ever obtained with water as the coupling medium is the work of B. Hadiomioglu and C. F. Quate, Appl. Phys. Lett. 43, 1006 (1983). They used sound pulses of frequency 4.4 GHz and 3 ns duration, with a lens of numerical aperture 0.73 and a radius of 15 μm . The resolution in the linear mode was 0.37 μm and with non-linearity was 0.24 μm . Non-linearity refers to the effect that if the amplitude of the sound near to the focus is sufficiently large, higher frequency harmonics are generated. The presence of these shorter wavelength components improves the resolution. Note that 3 ns at 4.4 GHz is only 13 cycles.

[0008] When the frequency is increased, the attenuation of the sound in water becomes a severe problem. In water, the attenuation in the GHz frequency range varies as the square of the frequency. At 38° C., human body temperature, the attenuation per unit distance in water is given by $\alpha=0.016 f^2 \mu\text{m}$, where f is the frequency in GHz. In a reflection microscope, it is necessary to have the time duration τ of the acoustic pulse less than the round trip time from the lens surface to the sample and back. When sound is generated by an electrically driven piezoelectric transducer, it is very difficult to make τ less than a few ns (say 5 ns), and so the acoustic path length has to be at least 8 μm and preferably somewhat longer. A 5 GHz sound wave would be attenuated by 35 dB after traveling 10 μm . Thus, for a given working distance from the lens to the sample object, the attenuation effectively controls the highest frequency that can be used and consequently limits the resolution. Water is the usual choice for a coupling medium because of its low attenuation. There are liquids with lower attenuation (e.g., He, H₂, CS₂, Hg, Ga), but there are difficulties in working with these materials. For example, He and H₂ cannot be used as coupling liquids at room temperature. For biological samples, water is the only possible coupling medium.

[0009] Thus, those skilled in the art desire a scanning acoustic microscope with improved resolution. In particular, those skilled in the art desire a scanning acoustic microscope that can use higher frequency pulses of shorter wavelength to improve the resolving power of the scanning acoustic microscope. Further, those skilled in the art desire a scanning acoustic microscope in which the sensor head can be positioned more closely to the sample being imaged to reduce attenuation of the sound waves used for imaging purposes by the coupling medium.

SUMMARY OF THE PREFERRED
EMBODIMENTS

[0010] A first embodiment of the present invention comprises an opto-acoustic transducer assembly comprising: a substrate comprised of material which is transparent to light used with the opto-acoustic transducer assembly; a layer of opto-acoustic material formed on a surface of the substrate, where the layer of opto-acoustic material generates sound waves when struck by light; and an acoustic lens to focus sound waves generated by the layer of opto-acoustic material.

[0011] A second embodiment of the present invention comprises a transducer assembly for use in an instrument

which is in turn used to probe a sample object, the transducer assembly having dual piezo-electric and opto-acoustic modes of operation, the transducer assembly comprising: a substrate; a layer of opto-acoustic material deposited on a surface of the substrate, the layer of opto-acoustic material being electrically conductive; a layer of piezo-electric material deposited on the layer of opto-acoustic material; a layer of electrically conductive material deposited on the layer of piezo-electric material; an acoustic lens; and whereby when a pulsed electric potential is applied between the layer of opto-acoustic material and the layer of conductive material, a pulsed electric field is created which causes the layer of piezo-electric material to deform and thereby create pulsed sound waves which are focused by the acoustic lens and then used to probe the sample object, and whereby after the pulsed sound waves interact with the sample object and are collected by the acoustic lens, the collected pulsed sound waves impinge the layer of opto-acoustic material thereby changing at least one optical property of the layer of opto-acoustic material.

[0012] A third embodiment of the present invention comprises a scanning acoustic microscope comprising: at least one light source for generating pulsed light, where the pulsed light will be used at least in a pump mode to generate pulsed sound waves to interact with a sample object to be probed using the pulsed sound waves; at least one opto-acoustic transducer assembly comprising: a substrate comprised of material which is transparent to the pulsed light generated by the at least one light source; a layer of opto-acoustic material formed on a surface of the substrate, where the layer of opto-acoustic material generates pulsed sound waves when struck by the pulsed light generated by the at least one light source; an acoustic lens to focus pulsed sound waves generated by the layer of opto-acoustic material; a pump mode optical assembly for coupling the pulsed light generated by the at least one light source to the substrate of the opto-acoustic transducer assembly, where the pulsed light coupled to the opto-acoustic transducer assembly by the pump mode optical assembly is used to generate sound waves to interact with the sample object; a table for mounting the sample object to be probed; and a computer control for controlling the operation of the scanning acoustic microscope.

[0013] A fourth embodiment of the present invention comprises a scanning acoustic microscope comprising: a piezo-electric transducer assembly comprising: a substrate; a layer of piezo-electric material formed on a surface of the substrate which generates pulsed sound waves to interact with a sample object to be probed with the pulsed sound waves when a voltage is applied to the layer of piezo-electric material; an acoustic lens formed in the substrate to focus the pulsed sound waves; a voltage source coupled to the layer of piezo-electric material; at least one opto-acoustic transducer assembly, where the opto-acoustic transducer assembly is operative to collect pulsed sound waves originally generated by the piezo-electric transducer assembly after the pulsed sound waves have interacted with the sample object, the opto-acoustic transducer assembly comprising: a substrate; a layer of opto-acoustic material formed on a surface of the substrate, where a property of the layer of opto-acoustic material changes when pulsed sound waves collected by the opto-acoustic transducer assembly impinge the layer of opto-acoustic material; an acoustic lens to collect pulsed sound waves generated by the piezo-electric transducer

assembly after the pulsed sound waves have interacted with the sample object; at least one light source for generating pulsed light, where the pulsed light will be used at least in a probe mode to measure the change in a property of the layer of opto-acoustic material caused by the pulsed sound waves collected by the opto-acoustic transducer assembly impinging the layer of opto-acoustic material after the pulsed sound waves have interacted with the sample object; a probe mode optical assembly for coupling the pulsed light generated by the at least one light source to the opto-acoustic transducer assembly; a table for mounting the sample object to be probed; and a computer control for controlling the operation of the scanning acoustic microscope.

[0014] A fifth embodiment of the present invention comprises a method for sensing physical properties of a sample object using an instrument having at least one opto-acoustic transducer assembly, the method comprising: generating pulsed light waves with a light source; directing the pulsed light waves to a layer of opto-acoustic material incorporated in the at least one opto-acoustic transducer assembly using a pump mode optical assembly; generating pulsed sound waves through the interaction of the layer of opto-acoustic material and the pulsed light waves directed to the layer of opto-acoustic material by the pump mode optical assembly; focusing the pulsed sound waves using at least one acoustic lens; coupling the pulsed sound waves to a coupling medium, whereby the coupled pulsed sound waves interact with the sample object and are changed in such a way that at least one physical property of the sample object can be sensed through the change brought about by the interaction; collecting the pulsed sound waves with the at least one acoustic lens after the pulsed sound waves have interacted with the sample object; coupling the collected pulsed sound waves onto a detector; sensing the properties of the sound waves using the detector; and deriving information concerning the sample object from the properties of the sound waves sensed by the detector.

[0015] A sixth embodiment of the present invention comprises a method for performing a physical operation on a sample object using an instrument having at least one opto-acoustic transducer assembly, the method comprising: generating pulsed light waves with a light source; directing the pulsed light waves to a layer of opto-acoustic material incorporated in the at least one opto-acoustic transducer assembly using a pump mode optical assembly; generating pulsed sound waves through the interaction of the layer of opto-acoustic material and the pulsed light waves directed to the layer of opto-acoustic material by the pump mode optical assembly; focusing the pulsed sound waves using at least one acoustic lens; coupling the pulsed sound waves to a coupling medium, whereby the focused pulsed sound waves perform a physical operation on the sample object.

[0016] Thus it is seen that embodiments of the present invention overcome the limitations of the prior art. In embodiments of the present invention acoustic waves used to probe various physical and mechanical properties of samples are generated by the interaction of pulsed light with a material having opto-acoustic properties. Due to the ability to generate ultra-short-width light pulses at a high repetition rate, pulsed sound waves used in embodiments of the present invention have much higher frequencies and much lower wavelengths than in prior art devices. Consequently, in

instruments operating in accordance with the present invention, higher frequency sound waves can be used, resulting in a much higher resolution.

BRIEF DESCRIPTION OF THE DRAWINGS

[0017] The foregoing and other aspects of these teachings are made more evident in the following Detailed Description of the Preferred Embodiments, when read in conjunction with the attached Drawing Figures, wherein:

[0018] **FIG. 1** depicts an opto-acoustic transducer assembly made in accordance with the present invention and suitable for use in a scanning acoustic microscope and other instruments;

[0019] **FIGS. 2A-2B** depict cross-sectional and bottom views, respectively, of another opto-acoustic transducer assembly made in accordance with present invention and suitable for use in a scanning acoustic microscope and other instruments;

[0020] **FIG. 3** depicts a further opto-acoustic transducer assembly made in accordance with the present invention and suitable for use in a scanning acoustic microscope and other instruments;

[0021] **FIG. 4** depicts yet another opto-acoustic transducer assembly made in accordance with the present invention and suitable for use in a scanning acoustic microscope and other instruments;

[0022] **FIGS. 5A-5B** depict cross-sectional and bottom views, respectively, of a still further opto-acoustic transducer assembly made in accordance with the present invention and suitable for use in a scanning acoustic microscope and other instruments;

[0023] **FIG. 6** depicts a transducer assembly having dual piezo-electric and opto-acoustic modes of operation made in accordance with the present invention and suitable for use in a scanning acoustic microscope;

[0024] **FIG. 7** is a graph depicting the results of a simulation showing the resolution of an opto-acoustic transducer assembly operating in accordance with the present invention;

[0025] **FIG. 8** is a graph depicting the results of a simulation showing the change in the reflectivity of a probe light pulse as a function of the time at which it is incident upon a transducer operating in accordance with the present invention;

[0026] **FIG. 9** depicts a line structure in a semiconductor device the properties of which can be probed with the apparatus and methods of the present invention;

[0027] **FIG. 10** is a schematic block diagram depicting a scanning acoustic microscope having an opto-acoustic transducer assembly, all made in accordance with the present invention;

[0028] **FIG. 11** is a schematic block diagram depicting another scanning acoustic microscope having an opto-acoustic transducer assembly, all made in accordance with the present invention;

[0029] **FIG. 12** is a schematic block diagram depicting a further scanning acoustic microscope having an opto-acoustic transducer assembly, all made in accordance with the present invention;

[0030] **FIG. 13** is a schematic block diagram of yet another scanning acoustic microscope having an opto-acoustic transducer assembly, all made in accordance with the present invention;

[0031] **FIG. 14** is a schematic block diagram of a still further scanning acoustic microscope having an opto-acoustic transducer assembly, all made in accordance with the present invention;

[0032] **FIG. 15** is a flow chart depicting a method operating in accordance with the present invention; and

[0033] **FIG. 16** is a flow chart depicting another method operating in accordance with the present invention.

DETAILED DESCRIPTION OF THE PREFERRED EMBODIMENTS

[0034] In certain embodiments of the present invention acoustic waves used to probe various physical and mechanical properties of samples are generated by the interaction of light waves with a material having opto-acoustic properties. In contrast, known scanning acoustic microscopes use piezoelectric transducers to generate sound. Due to the availability of light sources capable of generating ultra-short-duration light pulses, sound pulses of very short duration can be produced, e.g., pulses with duration below 1 ns, and as short as 0.1 ps. Due to the narrow width of sound pulses in instruments operating in accordance with the present invention, the distance from the sensor element to the sample object can be decreased, thereby reducing the effect of acoustic attenuation experienced in prior art instruments. Consequently, in instruments operating in accordance with the present invention, higher frequency sound waves can be used, resulting in a much higher resolution. In instruments incorporating the improvements of the present invention such as, for example, scanning opto-acoustic microscopes, a frequency of 15 GHz or higher can be used resulting in a lateral resolution for the microscope of 55 nm.

[0035] An embodiment of the present invention overcoming the limitations of the prior art comprises an opto-acoustic transducer assembly depicted in **FIG. 1**. The opto-acoustic transducer assembly depicted in **FIG. 1** is incorporated in a scanning acoustic microscope performing imaging operations, but one skilled in the art will appreciate that the opto-acoustic transducer assembly of the present invention can be used in other instruments to probe other physical and mechanical properties of a sample object.

[0036] The opto-acoustic assembly **10** depicted in **FIG. 1** comprises a substrate **12** in which a thin film **14** of a material having opto-acoustic properties is deposited onto a surface of a concave semi-hemispherical cavity **16**. The cavity, which operates as an acoustic lens **18**, can be formed by various methods known to those skilled in the art, for example in a polymeric material by using a silica sphere as a mold and etching out the silica sphere.

[0037] Alternatively, the hemispherical acoustic lens **18**, approximately 0.5 μm in radius, can be fabricated into sapphire (or comparable material) by electron beam grey scale lithography and dry etching. Amorphous As_2Se_3 is a compatible material which can be vacuum-deposited as the thin film transducer with high optical absorption at the pump laser wavelength, but this material is mentioned only as an example, since there are other suitable materials.

[0038] In order so that the opto-acoustic transducer 10 assembly need not contact the sample object 22 the angle defined by the surface of the concave semi-hemispherical cavity 16 in cross section is less than 180° . This is the reason the cavity is referred to as “semi-hemispherical.”

[0039] In an alternative implementation to that depicted in FIG. 1, an optically transparent pinhole (having a diameter less than 100 nm for example) is incorporated in the assembly to accommodate a near field optical imaging instrument, thereby providing dual, optical and acoustical imaging modes for the device.

[0040] In the opto-acoustic transducer assembly 10 depicted in FIG. 1, ultra-short-duration laser pulses 15 (for example, at a duration of 10^{-13} s) at a rapid repetition rate provide both the excitation input and the imaging input to the microscope via a thin film transducer 14 which is integrated into a focusing/imaging objective to convert optical energy to ultrasound and vice-versa. After travel through a sapphire substrate or equivalent 12, a “pump” laser pulse is absorbed in the transducer 14, causing an ultrashort transient stress. As the thickness of the transducer undergoes a sudden change, an acoustic pulse is launched into the coupling fluid 20 (for example, water). The acoustic pulse propagates and is focused by the acoustic lens 18 and interacts with a sample object 22 in a reflective mode, although other modes such as, for example, transmitting modes can be used in embodiments of the present invention. Upon return, changes in the optical constants of the thin film 14 are detected by a time-delayed probe laser pulse 17 shown after reflection off of the thin film 14.

[0041] In embodiments operating in a transmitting mode, two opto-acoustic transducer assemblies are employed. The first opto-acoustic transducer assembly generates sound waves to interact with the sample object, and the second opto-acoustic transducer assembly collects and detects sound waves after the sound waves have interacted with the sample object.

[0042] A particular advantage of optical generation of acoustic waves is that in instruments operating in accordance with the present invention, the acoustic path can be reduced to 1 μm or less, thereby decreasing the attenuation of the sound waves caused by the coupling medium. Other advantages of the present invention result from the reduction in the acoustic path—namely the ability to use a considerably higher acoustic frequency and thereby achieve a higher resolution than heretofore known in such instruments. In a scanning acoustic microscope operating in accordance with the present invention having the ability to precisely control the movement of the opto-acoustic transducer assembly 10, a 10-100 GHz ultrasound image will be acquired, mirroring local variations in acoustic material density at a nanoscale level.

[0043] As just noted, the acoustic path is short compared to the path between the transducer and the sample object for a conventional acoustic microscope. However, it is important to note that the distance of the transducer from the sample object can be kept large enough to make the risk of the transducer making mechanical contact with the sample object very small. Accidental mechanical contact with the sample object is a significant problem with other microscopy methods of comparable resolution, (e.g. near field scanning

optical microscopy and atomic force microscopy) because in these methods the distance of the scanning probe is less than 100 nm.

[0044] FIGS. 2A-B are cross-sectional and bottom views, respectively, depicting another embodiment of an opto-acoustic transducer assembly 40 operating in accordance with the present invention. The embodiment 40 depicted in FIG. 2 operates as an acoustic analogue to a Fresnel lens. In the embodiment depicted in FIG. 2, a plurality of non-contiguous rings of opto-acoustic material is deposited on a surface 44 of a substrate 46 and comprises a transducer and acoustic lens 42. Pump mode light pulses 45 are shown impinging on the transducer 42. Pulsed sound waves 47 are created by the interaction of the pump mode light pulses and opto-acoustic material. The pulsed sound waves 47 are then coupled to a coupling medium 48 and strike the sample object 50. The structure of the transducer and acoustic lens 42 operates on the principle of ultrasound wave diffraction. The alternate zones of the transducer and acoustic lens 42 are adjusted to have much different optical absorption so that the launch of the ultra-short strain pulses follows the zone plate’s spatial geometry (a burst of ultra-short-duration pulses is used in the Fresnel-lens-like embodiment so that the acoustic energy can be concentrated to a sharp focus by successive pulses arriving from different zones). The Fresnel-lens-like construction of the opto-acoustic transducer assembly 40 depicted in FIG. 2 has the advantage of being compatible with both crystalline and amorphous multi-layer materials and with microelectronic planar patterning and processing techniques. In one possible embodiment, the thin layer comprising the Fresnel-lens-like transducer 42 is formed by successively depositing layers of GaN, InGaN and Cr on a sapphire substrate. Embodiments constructed in this manner exploit the very large piezo effects in the GaN-based heterostructure system where inter-band optical absorption has been shown to offer means of generating intense high-frequency acoustic phonons.

[0045] In another embodiment of the Fresnel-lens-like optical transducer, each layer of the transducer 42 vibrates at a chosen frequency (e.g., 15 GHz) for several cycles (e.g., 2-10) after it is excited by a single pump pulse. The number of cycles that the transducer vibrates is determined by the difference between the acoustic impedance Z_f of the transducer material and the acoustic impedance Z_s of the substrate. (Acoustic impedance is the product of the mass density and the sound velocity.) If Z_f is much less than Z_s or if Z_f is much greater than Z_s then after the transducer film is excited by the pump light pulse the film will vibrate for several cycles before its oscillation is damped out. In this way it is possible to excite the Fresnel-lens-like optical transducer with a single pump light pulse and still produce constructive interference of the acoustic waves from the different zones at the acoustic focus.

[0046] In another embodiment of the Fresnel-lens-like optical transducer assembly 40 depicted in FIG. 2, the central zone 52 is maintained as being transparent. The maintenance of the transparency of the central zone 52 provides a sub-wavelength optical aperture for use by a near-field optical microscope in a scanning microscope having both acoustic and optical modes of operation.

[0047] A further embodiment of the opto-acoustic transducer assembly 60 of the present invention is depicted in

FIG. 3. In the embodiment depicted in **FIG. 3**, a planar layer **62** of opto-acoustic material is deposited on a surface **64** of a substrate **65**. When light pulses strike the planar layer **62** of opto-acoustic material sound waves are generated and propagate to a semi-hemispherical acoustic lens **66** formed in the substrate **65**, where they are focused. The sound waves are then coupled to a coupling fluid **68**, after which they interact with a sample object **70**.

[0048] The opto-acoustic transducers depicted in **FIGS. 1-3** above are designed to generate sound waves that are focused into a small volume with linear dimensions of the same order of magnitude as the wavelength of the sound. If the acoustic wavelength is very small, the sound is focused to a region close to a point, and consequently this is referred to as point focusing. "Point focusing" as described herein refers to what may be accomplished with practical apparatus.

[0049] It is also possible to use an opto-acoustical transducer that focuses sound into a region that is close to a line (line focusing) and this may be advantageous for the study of certain types of sample objects. There are a number of ways of achieving line focusing. One method is to use an opto-acoustic transducer in which the sound generated by the layer of opto-acoustic material is focused by a cylindrical surface as depicted in **FIG. 4**.

[0050] In the opto-acoustic transducer assembly **70** depicted in **FIG. 4**, a semi-cylindrical cavity **71** is formed in a substrate **72**. "Semi-cylindrical" refers to the fact that an angle subtended by the semi-cylindrical surface is less than 180° so that the substrate **72** need not contact the sample **78**. A layer of opto-acoustic material **74** is deposited on a surface **75** of the substrate. Pump mode light pulses **76** strike the layer of opto-acoustic material **74** and create pulsed sound waves. The pulsed sound waves propagate through the substrate **72** and are focused by the semi-cylindrical cavity **71**. The sound waves are then coupled to the coupling medium **77** after which they strike the sample object **78**.

[0051] In another embodiment capable of line focusing a structure analogous to the Fresnel-lens-like structure already described is used as depicted in **FIGS. 5A-5B**. The opto-acoustic transducer assembly **80** of this embodiment is shown in cross-section in **FIG. 5A** and from the bottom in **FIG. 5B**. The transducer and acoustic lens **81** comprises a plurality of parallel non-contiguous strips of opto-acoustic material deposited onto a planar surface **82** of a substrate **83**. As in the case of the other embodiments, pump mode pulsed light waves **84** impinge the transducer and acoustic lens **81**. The spacing and width of the strips of opto-acoustic material comprising the transducer and acoustic lens **81** are chosen so that the launch of the ultra-short strain pulses caused by the impinging probe mode light pulses **84** results in acoustic energy being concentrated to a line focus by successive pulses arriving from different strips. The focused sound pulses are then coupled to coupling medium **87** and strike sample object **87**.

[0052] Another embodiment of a transducer assembly suitable for use in a scanning acoustic microscope and operating in a dual piezo-electric and opto-acoustic mode is depicted in **FIG. 6**. In this particular embodiment, the dual-mode transducer **90** consists of a substrate **91** of material with low acoustic attenuation, such as sapphire. On an upper planar surface **92** of the substrate are deposited in

sequence a film **93** of As_2Te_3 , a film **94** of piezoelectric material such as zinc oxide, and a film **95** of indium tin oxide (ITO). ITO and As_2Te_3 are conducting materials. Consequently by making electrical connections to films **93**, **95** and applying a voltage to these connections, an electric field is produced across the piezoelectric film **94**. By applying the voltage as a short pulse it is possible to generate a sound pulse. This sound pulse travels down the substrate **91**, across the spherically-curved surface **96** at the bottom of the substrate and then comes to a focus in the coupling fluid **97**. After interacting with the sample **98**, the returning sound passes through the coupling fluid and travels up through the substrate to the As_2Te_3 film. Through the piezo-optic effect the sound changes the optical properties of this film. These changes are sensed through the application of an ultrashort light pulse **99**. Note that although the ITO film is an electrical conductor, it is transparent to light and thus the ultrashort light pulse is able to pass through it so as to sense the optical properties of the As_2Te_3 film. Other materials can be used for the detection film in place of As_2Te_3 , and other piezoelectric materials can be used in place of zinc oxide for the generation film.

[0053] In the embodiment of the present invention shown in **FIG. 6**, a piezoelectric transducer is used to generate sound and a light pulse is used to detect sound. It is also within the scope of the invention to generate sound using a light pulse and then detect sound with a piezoelectric transducer. It is also possible to use other types of acoustic transducers, e.g., magnetic transducers, in place of the piezoelectric film.

[0054] The resolving power of various embodiments of the opto-acoustic transducer assembly of the present invention has been estimated. For example, consider the Fresnel-lens-like embodiment depicted in **FIG. 2**. The acoustic lens consists of five elements with the center ring having an inner diameter of 400 nm and outer ring with outer diameter of 1600 nm. The distance from the center of the lens to the focus is 400 nm and the lens is designed for operation at 15 GHz. The sound field coming from the lens is calculated using Huygens' Principle including the $(1+\cos\theta)$ directional factor. The transducer is taken to be excited by a sequence of five light pulses at intervals of 67 ps, that is, $(15\text{ GHz})^{-1}$. In the simulation, the attenuation of the different Fourier components of the sound field is accounted for. The object is as two point reflectors located in the plane at 400 nm from the focus and separated by a distance d . **FIG. 7** shows a plot of the returning acoustic field integrated over the active area of the Fresnel lens as a function of the position of the lens relative to the object. The separation between the two point reflectors in **FIG. 7** is 55 nm. The simulations indicate that the lateral resolution of the microscope operating at 15 GHz is approximately 50 nm; this is based on the Sparrow criterion.

[0055] The vertical resolution depends on the signal-to-noise ratio of the overall system. For an object whose height varies smoothly with lateral position, height changes of a small fraction of the acoustic wavelength λ , i.e., 0.1 to 10 m can be resolved. The attenuation in water decreases monotonically with increasing temperature in the range 0 to 100°C .; the attenuation at 20°C . is 2.5 times the attenuation at 60°C . Thus the highest frequency that can be used decreases as the temperature goes down, and the resolution is lower.

[0056] For work with non-biological samples at room temperature (20° C.) fluids with attenuation lower than water may be used. At low frequencies where $\omega\tau < 1$ (ω is the angular frequency of the sound, and τ is the structural relaxation time), the attenuation varies as $\omega^2\tau$. However, if τ becomes so long that $\omega\tau > 1$, the attenuation varies as τ^{-1} and is independent of ω . In a glass-forming liquids τ becomes very large as the temperature is reduced towards the glass transition temperature and the attenuation (e.g., for >15 GHz) drops dramatically while the viscosity is still low enough for the liquid to be useful as a coupling fluid.

[0057] In the various embodiments depicted in FIGS. 1-5, a pump pulse of duration between 0.1 and 1000 ps is used to excite the transducer films of opto-acoustic material. The energy deposited in the transducer films by the pump pulse causes it to expand and this expansion launches a sound pulse into the water coupling medium. The sound travels to the acoustic focus and then returns to the transducer film in a reflective implementation. In a transmitting embodiment the sound waves continue to a second opto-acoustic transducer assembly. In either situation, when the sound waves enter the transducer film it causes a change in the optical properties of the film. This change is sensed by means of a time-delayed probe optical pulse. In the currently preferred embodiment, the pump and probe pulses come from the same pulsed laser source such as the Coherent Chameleon XR compact ultrafast laser. It is likely that in the next few years much less expensive lasers with similar performance will become commercially available. The delay of the probe pulse with respect to the pump is determined by changing the optical path for the probe pulse through the use of a retro-reflector mirror mounted on a computer-controlled translation stage, as will be shown in the following description of scanning acoustic microscopes incorporating opto-acoustic transducer assemblies of the present invention.

[0058] Different methods can be used to generate an acoustic pulse with a characteristic frequency f . In the case of the opto-acoustic transducer assembly having a concave acoustic lens as depicted in FIGS. 1, 3 and 4, it is possible to select a material and thickness for the thin film such that when excited by a single light pulse the film vibrates with the desired frequency. These vibrations will damp out in a certain time that is governed by the rate at which acoustic energy is transferred into the water coupling medium and into the substrate upon which the film is deposited. If the acoustic impedance Z_f of the film is small compared with the acoustic impedance Z_s of the substrate material upon which it is deposited, the film will form a so-called $\lambda/4$ resonator. Thus, the frequency of vibration will be $f=v/4d$ where v is the sound velocity in the film and d is the thickness. It may also be advantageous to use a film composed of multiple layers to obtain the desired frequency and at the same time achieve a good coupling of the sound from the film structure into the water. For the Fresnel-lens-like embodiment depicted in FIGS. 2A-2B, the transducer is excited by a series of light pulses (e.g., 2-10) so that the sound launched from each ring of the transducer arrives at the acoustic focus at the same time. Alternatively, a single pump light pulse can be used together with a transducer film that vibrates for several cycles after excitation as already described.

[0059] For any of the embodiments depicted in FIGS. 1-5, the time at which the probe pulse is applied can be selected so as to obtain the most useful information. FIG. 8 shows

the results of a simulation of the change in reflection of the probe light pulse as a function of the time of application of the probe pulse. This simulation is for an embodiment similar to that depicted in FIG. 1 with a lens radius of 500 nm, semi-angle 80 degrees, with a transducer film that vibrates at 15 GHz with a damping time of 300 ps. It can be seen that if the probe light pulse is applied at a time of 650 ps after the exciting pump pulse the signal will be a maximum. It may be preferable, however, to apply the probe pulse at a time such as 670 ps where the signal is varying rapidly with the time of application of the probe. If the probe pulse is applied at such a time, there will be a large change in the signal if the distances of the sample object from the lens changes.

[0060] To appreciate the advantage of this selection of the probe time, consider the application of the invention to the study of the surface topography of a sample, such as the surface of a planar optical element, e.g., an optical flat. The acoustic lens is moved laterally above the surface of the sample so that the acoustic focus is directed to different points on the surface. If a point on the surface of the nominally planar object is higher than the surrounding area, the acoustic pulse will return to the acoustic lens in less time when the acoustic focus is at this point. Hence, with the probe time set at 670 ps, this high point of the sample will give a decreased signal. For a point that is lower, the signal will be increased. Thus, the signal gives a measure of the height of the surface at the acoustic focus, and by measuring the signal while the acoustic lens is scanned across the surface it is possible to make a topographic map of the surface of the sample object. In an alternative procedure, the acoustic lens can be scanned laterally across the surface of the sample while the height of the lens is adjusted at each point so as to keep the signal at a constant level. The height of the lens is recorded as a function of the lateral position of the lens. A plot of the height of the lens as a function of lateral position gives a topographic map of the surface of the sample object.

[0061] The invention is well suited to the measurement of the topography of surfaces onto which have been placed high-aspect ratio structures. For example, in the semiconductor industry, thin films are etched to produce line or dot geometries as shown, for example, in FIG. 9. The spacing between these lines (see FIG. 9) may be as small as 50 nm, while the height may be several times the spacing. The geometry of such structures cannot be measured by optical microscopy because the light has too large a wavelength to penetrate to the bottom of the trenches between the lines. The very short acoustic wavelength of the sound pulses used in the present invention makes it possible for the sound to reach the bottom of the trenches and as a result the geometry of the structure can be measured.

[0062] While water has been the preferred coupling medium for most acoustic microscopes, it is possible that other liquids may be found to have more desirable properties for use in the current invention. Conventional acoustic microscopes have operated in the frequency range up to a few GHz, and in this frequency range water has a lower attenuation than other liquids that could be used (see above). However, in the new invention a higher acoustic frequency (10 GHz or higher) will be used and in this higher frequency range other liquids may have a lower attenuation.

[0063] The next portion of the disclosure will describe various embodiments of scanning acoustic microscopes incorporating opto-acoustic transducer assemblies, all made in accordance with various embodiments of the present invention. FIG. 10 depicts in schematic form a scanning acoustic microscope 100 of the present invention. A pulsed laser 110 generates a series of short light pulses. Each pulse is split into two by means of a polarizing beam splitter (“PBS”) 112. One component, “the pump pulse”, is directed into an acousto-optical modulator (“AOM”) 114, and then by mirrors 116, 118 to a reflector 120 mounted on a computer-controlled movable stage 122. Mirror 124 then directs the pulse to lens 126 which couples the light to the substrate of the opto-acoustic transducer assembly 130. The movable stage MS 122 is under the control of the digital computer DC 140, and is used to control the arrival time of the pump pulses at the transducer assembly TA 130.

[0064] The other component of the laser pulse coming from the polarizing beam splitter 112 is referred to as the “probe pulse.” Each probe pulse is directed by mirror M4150 to lens L1152 which focuses the light onto the opto-acoustic transducer assembly 130. After reflection by the layer of opto-acoustic material of the opto-acoustic transducer assembly, the probe pulses pass through the polarizer P1160 and are then detected by the optical detector PD1170. The polarizer 160 is oriented so as to block scattered pump light from reaching the detector. The output of this detector 170 is fed into the signal input of the lock-in amplifier L1100. The demodulated output from the lock-in amplifier 180 is directed to the digital computer DC 140 for analysis. The reference output from lock-in amplifier L1180 is used to drive the acousto-optical modulator AOM 114.

[0065] A sample is placed on a sample stage 132, and is coupled to the opto-acoustic transducer assembly 130 by a coupling fluid 134.

[0066] Examples of pulsed lasers suitable for use in the measuring system include an Argon ion-pumped Ti:sapphire laser such as the Inova/Mira system manufactured by Coherent, YAG lasers, and the Chameleon diode pumped Ti:sapphire laser manufactured by Coherent. These lasers generate light pulses with a repetition rate f_1 in the range 50 to 100 MHz, but lasers with pulse rates outside this range can also be used as a light source for this invention. A currently preferred frequency of operation f_2 for the acousto-optic modulator is 1 MHz. However, it may be preferable to use a different frequency in the range 1 kHz to 100 MHz according to the noise characteristics of the laser source that is used.

[0067] Each pump light pulse sets up a stress in the layer of opto-acoustic material incorporated in the opto-acoustic transducer assembly 130 that launches a sound pulse into the coupling fluid CF 134. After this sound pulse is reflected from the sample, it returns to the transducer 130 and causes a small change in the optical reflectivity of the opto-acoustic material incorporated in the opto-acoustic transducer assembly 130. The probe light pulse is used to measure this small change. The acousto-optic modulator AOM 114 varies the amplitude of the pump pulses at frequency f_2 and, as a consequence, the reflectivity of the sample is modulated by a small amount at this same frequency. This results in a modulation of the intensity of the reflected light. The voltage

output of the detector PD1170 is directed to the lock-in amplifier L1180 which detects the amplitude and phase of the output voltage.

[0068] In the presently preferred embodiments, the measured quantity is the change in the intensity of the reflected probe light. It is also within the scope of the invention to measure the change in other characteristics of the probe light after it has been reflected from the opto-acoustic material. These characteristics include, but are not limited to, the phase of the reflected light, the direction of the reflected light, and the polarization of the reflected light. It is also possible to measure the change in the intensity, or other characteristics, of the transmitted probe light.

[0069] The sample stage SS 132 provides positioning control of the sample in three dimensions. Let z be the axis perpendicular to the axis of the ultrasonic transducer and x and y axes perpendicular to z . Translating the sample in the z direction can be used to position the plane of the sample relative to the acoustic focus, and translation in x and y is used to make an ultrasonic image of the surface of the sample.

[0070] It is within the scope of the invention to use an electro-optic modulator in place of the acousto-optic modulator AOM 114.

[0071] FIG. 11 shows an alternative embodiment 200 in which the adjustable time-delay provided by the movable stage is applied to the probe pulses instead of to the pump pulses. In the embodiment depicted in FIG. 11, a pulsed laser 210 generates a series of short light pulses. Each pulse is split into two by means of a polarizing beam splitter (“PBS”) 212. The pump pulse is directed into acousto-optical modulator (“AOM”) 214, and then by mirror 216 to lens 226 which couples the light to the substrate of the opto-acoustic transducer assembly 230.

[0072] In the embodiment depicted in FIG. 11, the probe pulse is directed by mirror 250 to the reflector 253 mounted on movable stage 251. Each probe pulse is then directed by mirror 255 to lens L1252 which focuses the light onto the opto-acoustic transducer assembly 230. The movable stage MS 251 is under the control of the digital computer DC 240, and is used to control the arrival time of the probe pulses at the transducer assembly TA 230.

[0073] After reflection by the layer of opto-acoustic material of the opto-acoustic transducer assembly 230, the probe pulses pass through the polarizer P1260 and are then detected by the optical detector PD1270. The polarizer 260 is oriented so as to block scattered pump light from reaching the detector 270. The output of this detector 270 is fed into the signal input of the lock-in amplifier L1280. The demodulated output from the lock-in amplifier 280 is directed to the digital computer DC 240 for analysis. The reference output from lock-in amplifier L1280 is used to drive the acousto-optical modulator AOM 214.

[0074] A sample is placed on a sample stage 232, and is coupled to the opto-acoustic transducer assembly 230 by a coupling fluid 234.

[0075] FIG. 12 shows another embodiment 300 that includes an acousto-optic modulator AOM2 that modulates the probe light pulses at a frequency f_3 . The modulators AOM1314 and AOM2313 are driven at frequencies f_2 and f_3

by a frequency source not shown in the figure. This frequency source also provides a frequency f_2+f_3 to be used as the reference input for the lock-in amplifier 380. The advantage of modulating the amplitude of the probe as well as the pump is that the lock-in amplifier 380 rejects the signal arising from the part of the pump light that is scattered at the transducer assembly and then reaches the photodiode PD1370. It is also within the scope of this invention to use a frequency f_2-f_3 as the reference input for the lock-in amplifier 380. It is within the scope of the invention to use electro-optic modulators in place of the acousto-optic modulators.

[0076] In the embodiment depicted in FIG. 12, a pulsed laser 310 generates a series of short light pulses. Each pulse is split into two by means of a polarizing beam splitter 312. As indicated previously, both the pump pulse and probe pulses are directed into acousto-optical modulators AOM1314, AOM2313 respectively, where AOM1314 is driven at frequency f_2 and AOM2 is driven at frequency f_3 . The pump pulses are then directed by mirror 316 to lens 326 which couples the light to the substrate of the opto-acoustic transducer assembly 330.

[0077] After the AOM2313, the probe pulses are directed by mirror 350 to the reflector 353 mounted on movable stage 351. Each probe pulse is then directed by mirror 355 to lens L1357 which focuses the light onto the opto-acoustic transducer assembly 330. The movable stage MS 351 is under the control of the digital computer DC 340, and is used to control the arrival time of the probe pulses at the transducer assembly TA 330.

[0078] After reflection by the layer of opto-acoustic material of the opto-acoustic transducer assembly 330, the probe pulses pass through the polarizer P1360 and are then detected by the optical detector PD1370. The polarizer 360 is oriented so as to block scattered pump light from reaching the detector 370. The output of this detector 370 is fed into the signal input of the lock-in amplifier L1380. The demodulated output from the lock-in amplifier 380 is directed to the digital computer DC 340 for analysis. As indicated previously, the advantage of modulating the amplitude of the probe as well as the pump is that the lock-in amplifier 380 rejects the signal arising from the part of the pump light that is scattered at the transducer assembly and then reaches the photodiode PD1370.

[0079] As in the case of the other embodiments, a sample is placed on a sample stage 332. The sample object is in turn coupled to the opto-acoustic transducer assembly 330 by a coupling fluid 334.

[0080] FIG. 13 shows an embodiment of a scanning acoustic microscope 400 incorporating a frequency doubling crystal FDC 413. Light from the laser 410 is focused by lens L1411 onto the frequency doubling crystal 413. The light pulses emerging from FDC 413 contain a component which has twice the frequency of the entering light. Lens L2415 recollimates the light. Dichroic mirror DM 417 reflects the frequency doubled component of the light beam and transmits the undoubted component. The undoubted component is used for the pump pulses and the doubled component for the probe pulses. The half wave plate HWP 421 rotates the polarization of the probe by 90° . It is also within the scope of the invention to use a dichroic mirror that transmits the doubled component and reflects the undoubted component.

It is also within the scope of the invention to use a dichroic mirror that transmits the doubled component and reflects the undoubted component. Under certain conditions, it may be advantageous to use frequency doubled light for both the pump and probe.

[0081] It is also within the scope of the invention to use separate lasers for the pump and the probe that are synchronized so that a probe light pulse is produced by one laser at a chosen time after each pump pulse is produced by the other laser. With this arrangement, the wavelengths of the pump and probe can be chosen to have optimal values. Specifically, the pump wavelength should be such as to maximize the amplitude of the generated sound pulse in the coupling fluid, and the probe wavelength chosen to maximize the change in the optical reflectivity of the transducer for a given amplitude of the sound pulse returning from the sample.

[0082] FIG. 14 shows an embodiment of a scanning acoustic microscope 500 in which the same lens 565 is used to couple both the pump and the probe beams into the substrate of the opto-acoustic transducer assembly. The probe light is now directed by mirrors M4550 and M5551 to one side of the lens L1565. After the probe light is reflected from the opto-acoustic transducer assembly 530 it passes through the other side of the lens 565 and part of it is reflected by mirror M6566 to the photodiode PD1570. Mirror M6566 is partially transmitting and allows a fraction of the pump light to reach the sample through lens L1565.

[0083] In these embodiments, some fraction of the laser light that reaches the ultrasonic transducer will be reflected back along an optical path that causes it to return and enter the laser. Depending on the type of laser that is used and the amount of light that is reflected back this returning light can have deleterious effects on the laser stability. To avoid this problem it is sufficient to incorporate a Faraday isolator into the optical path.

[0084] It may be convenient to use an optical fiber to carry the light over some sections of the optical path.

[0085] In addition to embodiments in which sound is generated by means of an opto-acoustic transducer and generated by the same or by a different opto-acoustic transducer, the invention further comprises embodiments in which:

[0086] a) sound is generated by other means, (for example, through the use of the piezo-electric effect), and after interacting with the sample object is detected by an opto-acoustic transducer;

[0087] b) sound is generated by an opto-acoustic transducer and after interacting with the sample object is detected by other means, (for example, through the use of the piezo-electric effect).

[0088] These embodiments may be advantageous for certain sample objects.

[0089] In addition to the apparatus set forth previously, the present invention also concerns methods for using an instrument having an opto-acoustic transducer assembly for generating high-frequency, low-wavelength sound waves useful for sensing the physical properties of a sample.

[0090] In one such method of the present invention, the instrument is used to measure the surface topography of a

sample. In this application, the height of the surface of a solid would be measured as a function of lateral position. In one method for measuring the topography, the microscope lens can be scanned laterally across the surface of the solid, in raster fashion. The signal detected due to the return of the acoustic signal from the sample surface will depend on the height of the surface. In an alternate method, the microscope lens can be scanned laterally across the surface of the solid, in raster fashion in a similar manner to the first method. The signal detected due to the return of the acoustic signal from the sample surface will depend on the height of the surface, but in contrast to the first method, the height of the lens above the surface is adjusted so as to restore the detected signal to a reference value. The height of the lens will vary with lateral position in exactly the same way as the height of the surface.

[0091] In other embodiments of the methods of the present invention, an instrument is used to study the topography of layered structures. Consider, for example, a substrate that is covered by a thin film. The height of an opto-acoustic transducer operating in accordance with the present invention is first adjusted so that the sound is focused onto the upper (free) surface of the film. By performing a lateral scan of the opto-acoustic transducer the topography of this surface is determined. The height of the opto-acoustic transducer is then changed so that the sound is focused onto the interface between the substrate and the film. A lateral scan of the opto-acoustic transducer then gives the topography of this interface.

[0092] In operations in accordance with the present invention, acoustic waves penetrate into a sample object in addition to being reflected from it. The degree of penetration depends on the elastic properties of the sample. If the sample is a soft material, e.g., a polymer, with sound velocity and mass density in the same general range as water, then a substantial fraction of the energy of the acoustic wave will propagate across the water/sample interface. For a sample which has a very high sound velocity and/or a high density the transmission will be less. Because of this transmission of sound, instruments operating in accordance with the teachings of the present invention can be used to study the mechanical properties of the material near to the upper surface of a sample. For quantitative measurements, the amplitude S of the returning signal can be measured as a function of the height z of the transducer, of the time delay t_{pp} of the probe pulse and of the frequency f . The dependence of S on z , t_{pp} and f is then analyzed. The measured dependence of S can next be compared with a calculated dependence of S on z , t_{pp} and f based on postulated values of the elastic properties of the sample object. Then, the assumed elastic properties can be adjusted until a good agreement between the calculated and measured results is obtained. The calculation of S can be performed using the finite-element method or other computational approach.

[0093] If a sample object is covered in whole or in part by a thin layer of a surface contaminant, a determination of the elastic properties of this thin layer may in certain circumstances make it possible to identify the nature of the contaminant, e.g., the chemical composition.

[0094] If the sample object is a solid, when the acoustic pulse from the microscope enters into the sample object Rayleigh surface waves are generated. These Rayleigh sur-

face waves are very sensitive to cracks in the surface of the sample, and hence the presence of cracks shows up as a modification of the measured S . The higher the acoustic frequency the more sensitive the instrument is to small cracks, and thus for the detection of cracks the present invention will have a superior performance compared to conventional acoustic microscopes. Cracks can also be seen by impregnation with a fluorescent dye such as fluorescein and then looking for fluorescence from these regions. However, acoustic microscopy has been shown to reveal cracks that are not seen by fluorescence techniques. (See, for example, "Acoustic Microscopy of Rocks", A. Rodriguez-Rey, G. A. D. Briggs, T. A. Field and M. Montoto, *J. Microsc.* 160, 21 (1990). It is also possible to study cracks that result from nanoindentation. ("Observation of Surface Cracks with an Acoustic Microscope", K. Yamanata and Y. Enomoto, *J. Appl. Phys.* 53, 846 (1982)).

[0095] Measurements can also be made for a sample consisting of a thin film deposited onto a substrate. The adhesion of the film to the substrate can be determined. In such a sample, the part of the acoustic pulse that enters into the film will travel across the film and reach the interface between the film and the substrate. At that interface, part of the pulse will be reflected back towards the upper surface of the film and then towards the acoustic transducer, and part will continue into the substrate. The amplitude of the reflected component will be dependent on the quality of the adhesion of the film to the substrate. If the adhesion is poor, the reflection will be larger. A scan across the surface of the sample can provide a map of the adhesion as a function of position. Previous studies of adhesion as a function of position have been reported using the picosecond ultrasonic technique (see "Picosecond Ultrasonics Study of the Modification of Interfacial Bonding by Ion Implantation", G. Tas, J. J. Loomis, H. J. Maris, A. A. Bailes, and L. E. Seiberling, *Applied Physics Letters* 72, 2235 (1998)).

[0096] However, in that study a focused light pulse was used to directly excite sound waves in the thin film of the sample. As a consequence, the spatial resolution was limited, i.e., the light was focused to a spot of diameter approximately 20 μm . By an improved focusing system the size of the spot could be decreased to around 1 μm , but it would not be possible to achieve a focal diameter of better than 0.1 μm as is possible with the present invention. The key point is that the present invention focuses sound instead of light, and the wavelength of the sound can be made significantly less than the wavelength of light.

[0097] The invention can also be used to study sample objects that are immersed within the water coupling medium (or other liquid). For example, the sample could be a biological cell adhering to a substrate. The invention could be used to determine the mechanical properties of different parts of the cell, or to determine the locations of different elements within the cell. Studies of this type have been performed with conventional acoustic microscopes ("Scanning acoustic microscopy visualizes cytomechanical responses to cytochalasin", J. Bereiter-Hahn, *Journal of Microscopy* 146, 29 (1987); "Acoustic microscopy of red blood cells", E. A. Schenk, R. W. Waag, A. B. Schenk and J. P. Aubuchon, *Journal of Histochemistry and Cytochemistry* 36, 1341 (1988); "Measurement of cellular elastic properties by acoustic microscopy", J. A. Hildebrand and D. Rugar, *Journal of Microscopy* 134, 245 (1984).)

[0098] In summary, general aspects of methods operating in accordance with the present invention for performing sample probing operations are set forth in the flow chart of **FIG. 15**. At step **612**, pulsed light waves are generated by a light source. Then at step **614**, the pulsed light waves are directed by a pump mode optical assembly to a layer of opto-acoustic material incorporated in an opto-acoustic transducer assembly operating in accordance with the present invention. Pulsed sound waves are generated at step **616** through the interaction of the layer of opto-acoustic material and the pulsed light waves directed to the layer of opto-acoustic material by the pump mode optical assembly. Next, at steps **618** and **620**, the pulsed sound waves are focused and coupled to a coupling medium in which a sample object is immersed. After the pulsed sound waves have interacted with the sample object, the acoustic lens collects the pulsed sound waves at step **622**. Then at step **624** the collected sound waves are coupled to a detector. Next, at step **626**, the properties of the sound waves are sensed using the detector. Then, at step **628**, information concerning the sample object is derived from the properties of the sound waves sensed by the detector.

[0099] In one variant of the method depicted in **FIG. 15**, a probe mode light source, the opto-acoustic transducer assembly and a probe mode optical assembly function as the detector in steps **624-628**. In other variants of the method depicted in **FIG. 15**, a piezo-electric transducer assembly functions as the detector.

[0100] In still further variants, the method depicted in **FIG. 15** operates in scanning and non-scanning modes. In scanning modes, the method is used to collect topographical information concerning a sample object. The topographical information may concern an uppermost surface of a sample object, or inner layers of a multi-layer structure.

[0101] An instrument operating in accordance with the method of **FIG. 15** can be used both in scanning and non-scanning modes to measure the mechanical properties of a sample object.

[0102] As well as serving as a focused source of ultrasonic waves for microscopy imaging purposes, the opto-acoustic transducer in conjunction with the pump mode optical assembly has other applications as a focusing acoustic optic source. The following examples are cited but other applications will be apparent to those skilled in the art:

[0103] 1) The high amplitude sound in the vicinity of the acoustic focus can be used as acoustical tweezers in the manner described by J. Wu, *J. Acoust. Soc. Am.* 89, 2140 (1991). In that work, frequencies in the MHz range were used giving an acoustic focus of large extent. With the opto-acoustic transducer of this invention, the diameter of the acoustic focus can be approximately 1000 times smaller and will be more effective for trapping very small objects, i.e., objects with dimensions in the range from 100 nm down to 10 nm.

[0104] 2) The high amplitude sound in the vicinity of the focus can also be used for materials processing on the nanoscale. The following examples are cited but other applications will be apparent to those skilled in the art.

[0105] a) It is known that high amplitude sound can modify the chemical bonding in materials. V. I. Trigub and A. V. Plotnov (*Technical Physics Letters*, vol. 28, no.6, June

2002, p. 8-10) have demonstrated this process by application of 21 kHz ultrasound to MMA-MAA copolymer photoresist. Through the use of the opto-acoustic transducer, it is possible to induce these modifications in chemical bonding in selected regions of material that have dimensions of the order of the acoustic focus, i.e., dimensions below 100 nm.

[0106] b) It is known that high amplitude sound can be used to implant atoms into metal surfaces (Y. Arata, Yue-Chang Zhang; *Applied Physics Letters*, vol. 80, no13, 1 April 2002, p. 2416-18). Through the use of the opto-acoustic transducer, it is possible to perform this implantation in selected regions of material that have dimensions of the order of the acoustic focus, i.e., dimensions below 100 nm.

[0107] c) It is known that high amplitude sound can be used to modify the mechanical properties of a surface (I. V. Ostrovskii, L. P. Steblenko, A. B. Nadtochii, *Semiconductors*, vol. 34, no3, March 2000, p. 251-4). Through the use of the opto-acoustic transducer, it is possible to perform this modification in selected regions of material that have dimensions of the order of the acoustic focus, i.e., dimensions below 100 nm.

[0108] Since the invention can produce modifications of material properties in a selected region of material near to a surface, it can be used to repair defects on computer chips and to repair the masks that are used in computer chip fabrication. It can also be used to directly write patterns onto chips or onto masks.

[0109] In summary, general aspects of methods operating in accordance with the present invention for altering at least one physical property of a sample object are depicted in the flow chart of **FIG. 16**. At step **712**, pulsed light waves are generated by a light source. Then at step **714** the pulsed light waves are directed by a pump mode optical assembly to a layer of opto-acoustic material incorporated in an opto-acoustic transducer assembly. Next, at step **716** pulsed sound waves are generated through the interaction of the layer of opto-acoustic material and the pulsed light waves directed to the layer of opto-acoustic material by the pump mode optical assembly. An acoustic lens focuses the pulsed sound waves at step **718**. Then at step **720** the pulsed sound waves are coupled to a coupling medium, whereby the focused pulsed sound waves perform a physical operation on a sample object.

[0110] In variants of the method depicted in **FIG. 16** various physical operations can be performed on a sample object. For example, in one variant an acoustic tweezers operation can be performed on a sample object. In other variants, repairs can be performed on masks used in semiconductor fabrication; semiconductor wafers; or semiconductor chips. In further variants patterns can be formed on masks used in semiconductor fabrication; semiconductor wafers; or semiconductor chips.

[0111] Thus it is seen that the foregoing description has provided by way of exemplary and non-limiting examples a full and informative description of the best methods and apparatus presently contemplated by the inventors for performing high resolution imaging and other sample probing operations using opto-acoustic principles. One skilled in the art will appreciate that the various embodiments described herein can be practiced individually; in combination with

one or more other embodiments described herein; or in combination with scanning acoustic microscopes and other instruments differing from those described herein. Further, one skilled in the art will appreciate that the present invention can be practiced by other than the described embodiments; that these described embodiments are presented for the purposes of illustration and not of limitation; and that the present invention is therefore limited only by the claims which follow.

We claim:

1. An opto-acoustic transducer assembly comprising:
 - a substrate comprised of material which is transparent to light used with the opto-acoustic transducer assembly;
 - a layer of opto-acoustic material formed on a surface of the substrate, where the layer of opto-acoustic material generates sound waves when struck by light; and
 - an acoustic lens to focus sound waves generated by the layer of opto-acoustic material.
2. The opto-acoustic transducer assembly of claim 1 where the acoustic lens comprises a concave cavity formed in the substrate.
3. The opto-acoustic transducer assembly of claim 2 where the layer of opto-acoustic material is deposited on a surface of the substrate bounding the concave cavity.
4. The opto-acoustic transducer assembly of claim 2 where the concave cavity is semi-hemispherical, whereby sound waves generated by the layer of opto-acoustic material when struck by light are focused substantially to a point focus by the acoustic lens.
5. The opto-acoustic transducer assembly of claim 2 where the concave cavity is partially cylindrical, whereby sound waves generated by the layer of opto-acoustic material when struck by light are focused substantially to a line focus by the acoustic lens.
6. The opto-acoustic transducer assembly of claim 2 where the layer of opto-acoustic material and the acoustic lens are formed on opposite sides of the substrate.
7. The opto-acoustic transducer assembly of claim 1 where the opto-acoustic material comprises As_2Te_3 .
8. The opto-acoustic transducer assembly of claim 1 where the layer of opto-acoustic material is deposited on the surface of the substrate in a plurality of non-contiguous concentric rings, and whereby the non-contiguous concentric rings further comprise the acoustic lens which focuses the sound waves generated by the layer of opto-acoustic material substantially to a point focus.
9. The opto-acoustic transducer assembly of claim 1 where the layer of opto-acoustic material vibrates after being struck by a single pulse of light of predetermined characteristics for a predetermined number of cycles at a predetermined frequency before damping out, where the predetermined number of cycles is dependent upon respective acoustic impedances of the layer of opto-acoustic material and the substrate.
10. The opto-acoustic transducer assembly of claim 9 where the predetermined frequency is at least 15 GHz.
11. The opto-acoustic transducer assembly of claim 9 where the predetermined number of cycles is between 2 and 10, inclusive.
12. The opto-acoustic transducer assembly of claim 1 where the layer of opto-acoustic material is deposited on the surface of the substrate in a plurality of non-contiguous

parallel strips, and whereby the non-contiguous parallel strips further comprise the acoustic lens which focuses the sound waves generated by the layer of opto-acoustic material substantially to a line focus.

13. The opto-acoustic transducer assembly of claim 8 where the layer of opto-acoustic material is formed from at least one of GaN; InGaN; Cr.

14. The opto-acoustic transducer assembly of claim 8 where a central region defined by an innermost ring of opto-acoustic material is transparent and functions as a sub-wavelength optical aperture for a near-field optical microscope.

15. The opto-acoustic transducer assembly of claim 8 where the plurality of non-contiguous concentric rings is formed from multiple layers deposited on the surface of the substrate.

16. The opto-acoustic transducer assembly of claim 15 where one of the multiple layers comprises GaN.

17. The opto-acoustic transducer assembly of claim 15 where one of the multiple layers comprises InGaN.

18. The opto-acoustic transducer assembly of claim 15 where one of the multiple layers comprises Cr.

19. The opto-acoustic transducer assembly of claim 1 where the substrate comprises sapphire.

20. The opto-acoustic transducer assembly of claim 1 whereby the acoustic lens of the opto-acoustic transducer assembly is operative to collect sound waves originally generated by the layer of opto-acoustic material after the sound waves have interacted with a sample object, and where a property of the layer of opto-acoustic material changes when the collected sound waves impinge the layer of opto-acoustic material.

21. The opto-acoustic transducer assembly of claim 20 where the property is the reflectivity of the opto-acoustic material.

22. The opto-acoustic transducer assembly of claim 20 whereby the change in a property of the layer of opto-acoustic material caused by sound waves impinging the layer of opto-acoustic material in turn changes at least one of a following property of light of predetermined characteristics impinging the layer of opto-acoustic material: an intensity of the light; a phase of the light; a direction of the light; a polarization of the light.

23. The opto-acoustic transducer assembly of claim 1 where the opto-acoustic transducer assembly comprising, in part, a layer of opto-acoustic material which generates sound waves when struck by light comprises a first opto-acoustic transducer assembly, the first opto-acoustic transducer assembly operating in combination with:

- a second opto-acoustic transducer assembly, where the second opto-acoustic transducer assembly is operative to collect sound waves originally generated by the first opto-acoustic transducer assembly after the sound waves have interacted with a sample object, the second opto-acoustic transducer assembly comprising:

- a second substrate;

- a second layer of opto-acoustic material formed on a surface of the second substrate whereby when sound waves impinge the second layer of opto-acoustic material a property of the opto-acoustic material changes; and

- a second acoustic lens.

24. The opto-acoustic transducer assembly of claim 23 where the property of the second layer of opto-acoustic material which changes is a reflectivity of the second layer of opto-acoustic material.

25. The opto-acoustic transducer assembly of claim 23 whereby the change in a property of the second layer of opto-acoustic material caused by sound waves impinging the second layer of opto-acoustic material in turn changes at least one of a following property of light of predetermined characteristics impinging the second layer of opto-acoustic material: an intensity of the light; a phase of the light; a direction of the light; a polarization of the light.

26. A transducer assembly for use in an instrument which is in turn used to probe a sample object, the transducer assembly having dual piezo-electric and opto-acoustic modes of operation, the transducer assembly comprising:

a substrate;

a layer of opto-acoustic material deposited on a surface of the substrate, the layer of opto-acoustic material being electrically conductive;

a layer of piezo-electric material deposited on the layer of opto-acoustic material;

a layer of electrically conductive material deposited on the layer of piezo-electric material;

an acoustic lens; and

whereby when a pulsed electric potential is applied between the layer of opto-acoustic material and the layer of conductive material, a pulsed electric field is created which causes the layer of piezo-electric material to deform and thereby create pulsed sound waves which are focused by the acoustic lens and then used to probe the sample object, and whereby after the pulsed sound waves interact with the sample object and are collected by the acoustic lens, the collected pulsed sound waves impinge the layer of opto-acoustic material thereby changing at least one optical property of the layer of opto-acoustic material.

27. A scanning acoustic microscope comprising:

at least one light source for generating pulsed light, where the pulsed light will be used at least in a pump mode to generate pulsed sound waves to interact with a sample object to be probed using the pulsed sound waves;

at least one opto-acoustic transducer assembly comprising:

a substrate comprised of material which is transparent to the pulsed light generated by the at least one light source;

a layer of opto-acoustic material formed on a surface of the substrate, where the layer of opto-acoustic material generates pulsed sound waves when struck by the pulsed light generated by the at least one light source;

an acoustic lens to focus pulsed sound waves generated by the layer of opto-acoustic material;

a pump mode optical assembly for coupling the pulsed light generated by the at least one light source to the substrate of the opto-acoustic transducer assembly, where the pulsed light coupled to the opto-acoustic

transducer assembly by the pump mode optical assembly is used to generate sound waves to interact with the sample object;

a table for mounting the sample object to be probed; and

a computer control for controlling the operation of the scanning acoustic microscope.

28. The scanning acoustic microscope of claim 27 further comprising:

a probe mode optical assembly for coupling pulsed light generated by the at least one light source to the at least one opto-acoustic transducer assembly, where the pulsed light generated by the at least one light source coupled to the at least one opto-acoustic transducer assembly by the probe mode optical assembly is used to sense a change in an optical property of the layer of opto-acoustic material caused by sound waves after they have interacted with the sample object being probed by the scanning acoustic microscope.

29. The scanning acoustic microscope of claim 28 where the optical property is a reflectivity of the layer of opto-acoustic material.

30. The scanning acoustic microscope of claim 28 whereby the change in a property of the layer of opto-acoustic material caused by sound waves impinging the layer of opto-acoustic material in turn changes at least one of a following property of light of predetermined characteristics impinging the layer of opto-acoustic material: an intensity of the light; a phase of the light; a direction of the light; a polarization of the light.

31. The scanning acoustic microscope of claim 28 where the scanning acoustic microscope operates in a reflection mode, whereby pulsed sound waves are reflected by the sample object back to the at least one opto-acoustic transducer assembly, and where the scanning acoustic microscope further comprises:

a beamsplitter for splitting pulsed light generated by the at least one light source, where resulting component pulsed light beams are coupled to the pump mode optical assembly and the probe mode optical assembly, respectively.

32. The scanning acoustic microscope of claim 28 whereby the scanning acoustic microscope operates in a reflection mode, and where:

the at least one light source further comprises a first and second light source, where the first light source generates pulsed light for coupling to the pump mode optical assembly and where the second light source generates pulsed light for coupling to the probe mode optical assembly.

33. The scanning acoustic microscope of claim 32 where the first light source coupled to the pump mode optical assembly is optimized for operation with the layer of opto-acoustic material to generate pulsed sound waves.

34. The scanning acoustic microscope of claim 32 where the second light source coupled to the probe mode optical assembly is optimized for operation with the layer of opto-acoustic material to measure changes in an optical property of the layer of opto-acoustic material caused by sound waves impinging the layer of opto-acoustic material.

35. The scanning acoustic microscope of claim 28 whereby the scanning acoustic microscope operates in a transmission mode, and where:

the at least one opto-acoustic transducer assembly further comprises a first and second opto-acoustic transducer assembly, where the first opto-acoustic transducer assembly is coupled to the pump mode optical assembly and generates pulsed sound waves for interacting with the sample object to be probed by the scanning acoustic microscope and where the second opto-acoustic transducer assembly is coupled to the probe mode optical assembly, where the pulsed light coupled to the second opto-acoustic transducer assembly by the probe mode optical assembly is used to sense the change of an optical property of the opto-acoustic material when pulsed sound waves transmitted by the sample object impinge the opto-acoustic material.

36. The scanning acoustic microscope of claim 35 where:

the at least one light source further comprises a first and second light source, where the first light source generates pulsed light for coupling to the pump mode optical assembly and where the second light source generates pulsed light for coupling to the probe mode optical assembly.

37. The scanning acoustic microscope of claim 36 where the first light source coupled to the pump mode optical assembly is optimized for operation with the layer of opto-acoustic material to generate pulsed sound waves.

38. The scanning acoustic microscope of claim 36 where the second light source coupled to the probe mode optical assembly is optimized for operation with the layer of opto-acoustic material to measure changes in an optical property of the layer of opto-acoustic material caused by sound waves impinging the layer of opto-acoustic material.

39. The scanning acoustic microscope of claim 27 further comprising a coupling fluid for coupling the sound waves generated by the opto-acoustic transducer assembly to the sample object.

40. The scanning acoustic microscope of claim 28 further comprising:

a photodetector for detecting the probe mode pulsed light waves after the probe mode pulsed light waves have reflected off of the layer of opto-acoustic material of the opto-acoustic transducer assembly.

41. The scanning acoustic microscope of claim 40 further comprising:

a polarizer for preventing scattered pump-mode light pulses from reaching the photodetector.

42. The scanning acoustic microscope of claim 28 further comprising:

a pump mode modulation means for modulating an amplitude of the pump mode pulsed light prior to the pump mode pulsed light impinging the layer of opto-acoustic material of the opto-acoustic transducer assembly.

43. The scanning acoustic microscope of claim 42 where the pump mode modulation means comprises an electro-optic modulator.

44. The scanning acoustic microscope of claim 42 where the pump mode modulation means comprises an acousto-optic modulator.

45. The scanning acoustic microscope of claim 42 further comprising:

a lock-in amplifier coupled to an output of the photodetector and an input of the pump mode modulation

means for controlling the pump mode modulation means in dependence upon a signal received from the photodetector.

46. The scanning acoustic microscope of claim 28 where the pump mode optical assembly further comprises a reflector mounted on a movable stage, where the movable stage is coupled to the computer control and is operative to control a difference in arrival times between pump mode pulsed light and probe mode pulsed light at the opto-acoustic transducer assembly.

47. The scanning acoustic microscope of claim 28 where the probe mode optical assembly further comprises a reflector mounted on a movable stage, where the movable stage is coupled to the computer control and is operative to control a difference in arrival times between pump mode pulsed light and probe mode pulsed light at the opto-acoustic transducer assembly.

48. The scanning acoustic microscope of claim 42 where the pump mode modulation means operates at a first frequency, the probe mode optical assembly further comprising:

a probe mode modulation means for modulating the amplitude of the probe mode pulsed light at a second frequency different from the first frequency used to modulate the pump mode pulsed light, the modulation of the probe mode pulsed light occurring prior to the probe mode pulsed light impinging the layer of opto-acoustic material of the opto-acoustic transducer assembly.

49. The scanning acoustic microscope of claim 48 where the probe mode modulation means comprises an electro-optic modulator.

50. The scanning acoustic microscope of claim 48 where the pump mode modulation means comprises an acousto-optic modulator.

51. The scanning acoustic microscope of claim 28 further comprising:

a frequency-doubling crystal for creating a frequency component at twice a nominal frequency of the of the light source prior to the coupling of the pulsed light to the pump and probe mode optical assemblies.

52. The scanning acoustic microscope of claim 51 further comprising:

a dichroic mirror that transmits a frequency component of pulsed light at the nominal frequency of the at least one light source to the pump mode optical assembly and reflects the component at twice the nominal frequency to the probe mode optical assembly.

53. The scanning acoustic microscope of claim 51 further comprising:

a dichroic mirror that transmits a frequency component of pulsed light at the nominal frequency of the at least one light source to the probe mode optical assembly and reflects the component at twice the nominal frequency to the pump mode optical assembly.

54. The scanning acoustic microscope of claim 52 further comprising:

a half-wave plate for rotating a polarization of the probe mode pulsed light coupled to the probe mode optical assembly by the dichroic mirror.

55. The scanning acoustic microscope of claim 27 further comprising:

a near-field optical microscope, whereby the scanning acoustic microscope and near-field optical microscope provide dual, optic and acoustic, modes of operation.

56. The scanning acoustic microscope of claim 27 where the layer of opto-acoustic material is deposited on the surface of the substrate in a plurality of non-contiguous concentric rings, and whereby the non-contiguous concentric rings further comprise the acoustic lens, and where a central region formed by an innermost ring of opto-acoustic material is transparent and functions as a sub-wavelength optical aperture for a near-field optical microscope, the scanning acoustic microscope further comprising:

the near-field optical microscope, whereby the scanning acoustic microscope and near-field optical microscope provide dual, optic and acoustic, modes of operation.

57. The scanning acoustic microscope of claim 27 further comprising:

a piezo-electric transducer assembly, where the piezo-electric transducer assembly is operative to collect pulsed sound waves originally generated by the opto-acoustic transducer assembly after the pulsed sound waves have interacted with the sample object, the piezo-electric transducer assembly comprising:

a substrate;

a layer of piezo-electric material formed on a surface of the substrate, at least one electrical property of the layer of piezo-electric material changing when pulsed sound waves impinge the layer of piezo-electric material;

an acoustic lens formed in the substrate to collect the pulsed sound waves originally generated by the opto-acoustic transducer assembly after the pulsed sound waves have interacted with the sample object; and

means to measure the change in the at least one electrical property of the layer of piezo-electric material.

58. A scanning acoustic microscope comprising:

a piezo-electric transducer assembly comprising:

a substrate;

a layer of piezo-electric material formed on a surface of the substrate which generates pulsed sound waves to interact with a sample object to be probed with the pulsed sound waves when a voltage is applied to the layer of piezo-electric material;

an acoustic lens formed in the substrate to focus the pulsed sound waves;

a voltage source coupled to the layer of piezo-electric material;

at least one opto-acoustic transducer assembly, where the opto-acoustic transducer assembly is operative to collect pulsed sound waves originally generated by the piezo-electric transducer assembly after the pulsed

sound waves have interacted with the sample object, the opto-acoustic transducer assembly comprising:

a substrate;

a layer of opto-acoustic material formed on a surface of the substrate, where a property of the layer of opto-acoustic material changes when pulsed sound waves collected by the opto-acoustic transducer assembly impinge the layer of opto-acoustic material;

an acoustic lens to collect pulsed sound waves generated by the piezo-electric transducer assembly after the pulsed sound waves have interacted with the sample object;

at least one light source for generating pulsed light, where the pulsed light will be used at least in a probe mode to measure the change in a property of the layer of opto-acoustic material caused by the pulsed sound waves collected by the opto-acoustic transducer assembly impinging on the layer of opto-acoustic material after the pulsed sound waves have interacted with the sample object;

a probe mode optical assembly for coupling the pulsed light generated by the at least one light source to the opto-acoustic transducer assembly;

a table for mounting the sample object to be probed; and a computer control for controlling the operation of the scanning acoustic microscope.

59. A method for sensing physical properties of a sample object using an instrument having at least one opto-acoustic transducer assembly, the method comprising:

generating pulsed light waves with a light source;

directing the pulsed light waves to a layer of opto-acoustic material incorporated in the at least one opto-acoustic transducer assembly using a pump mode optical assembly;

generating pulsed sound waves through the interaction of the layer of opto-acoustic material and the pulsed light waves directed to the layer of opto-acoustic material by the pump mode optical assembly;

focusing the pulsed sound waves using at least one acoustic lens;

coupling the pulsed sound waves to a coupling medium, whereby the coupled pulsed sound waves interact with the sample object and are changed in such a way that at least one physical property of the sample object can be sensed through the change brought about by the interaction;

collecting the pulsed sound waves with the at least one acoustic lens after the pulsed sound waves have interacted with the sample object;

coupling the collected pulsed sound waves onto a detector;

sensing the properties of the sound waves using the detector; and

deriving information concerning the sample object from the properties of the sound waves sensed by the detector.

60. The method of claim 59 whereby the detector comprises the at least one opto-acoustic transducer assembly and where sensing the properties of the sound waves further comprises:

directing probe-mode pulsed light waves to the layer of opto-acoustic material of the at least one opto-acoustic transducer assembly using a probe mode optical assembly, where the collected pulsed sound waves impinging the layer of opto-acoustic material change at least one optical property of the layer of opto-acoustic material, and whereby the probe-mode pulsed light waves are used to measure the change in the at least one optical property of the layer of opto-acoustic material caused by the impinging pulsed sound waves.

61. The method of claim 59 whereby the detector comprises a piezo-electric device.

62. The method of claim 59, where the instrument is used in a scanning mode.

63. The method of claim 62, where the information comprises an image of the sample object.

64. The method of claim 62, where the information concerns the topography of the sample object.

65. The method of claim 64, where the method further comprises:

scanning the opto-acoustic transducer assembly in two dimensions across a surface of the sample object to collect information sample points, where each of the sample points concern height information about the surface of the sample object at particular (x,y) coordinates on the surface of the sample object.

66. The method of claim 65 where the height information is determined by adjusting the height of the opto-acoustic transducer assembly.

67. The method of claim 59, where the information concerns the mechanical properties of the sample object.

68. The method of claim 59, where the information concerns cracks present in the sample object.

69. A method for performing a physical operation on a sample object using an instrument having at least one opto-acoustic transducer assembly, the method comprising:

generating pulsed light waves with a light source;

directing the pulsed light waves to a layer of opto-acoustic material incorporated in the at least one opto-acoustic transducer assembly using a pump mode optical assembly;

generating pulsed sound waves through the interaction of the layer of opto-acoustic material and the pulsed light waves directed to the layer of opto-acoustic material by the pump mode optical assembly;

focusing the pulsed sound waves using at least one acoustic lens;

coupling the pulsed sound waves to a coupling medium, whereby the focused pulsed sound waves perform a physical operation on the sample object.

70. The method of claim 69 where the physical operation is an acoustic tweezers operation.

71. The method of claim 69 where the sample object is a mask used in semiconductor fabrication and where the physical operation comprises a repair of the mask.

72. The method of claim 69 where the sample object is a mask used in semiconductor fabrication and where the physical operation comprises forming a pattern on the mask.

73. The method of claim 69 where the sample object is a semiconductor wafer and the physical operation comprises a repair of the semiconductor wafer.

74. The method of claim 69 where the sample object is a semiconductor wafer and the physical operation comprises forming a pattern on the semiconductor wafer.

75. The method of claim 69 where the sample object is a semiconductor chip and the physical operation comprises a repair of the semiconductor chip.

76. The method of claim 69 where the sample object is a semiconductor chip and the physical operation comprises forming a pattern on the semiconductor chip.

* * * * *